

## TEST REPORT

**Report No.: 17050992HKG-002**

International Toy, Inc.

Application For Certification  
(Original Grant)

**FCC ID: 2AIRRINT106**

Transceiver

**PREPARED AND CHECKED BY:**

**APPROVED BY:**

Signed On File  
Josie Yao  
Engineer

---

Koo Wai Ip  
Technical Supervisor  
Date: June 05, 2017

---

Intertek's standard Terms and Conditions can be obtained at our website <http://www.intertek.com/terms/>.

The test report only allows to be revised within the retention period unless further standard or the requirement was noticed

This report is for the exclusive use of Intertek's Client and is provided pursuant to the agreement between Intertek and its Client. Intertek's responsibility and liability are limited to the terms and conditions of the agreement. Intertek assumes no liability to any party, other than to the Client in accordance with the agreement, for any loss, expense or damage occasioned by the use of this report. Only the Client is authorized to permit copying or distribution of this report and then only in its entirety. Any use of the Intertek name or one of its marks for the sale or advertisement of the tested material, product or service must first be approved in writing by Intertek. The observations and test results in this report are relevant only to the sample tested. This report by itself does not imply that the material, product, or service is or has ever been under an Intertek certification program.

© 2017 Intertek

**TEST REPORT****GENERAL INFORMATION**

<b>Grantee:</b>	International Toy, Inc.
<b>Grantee Address:</b>	2151, Michelson Drive STE 185, Irvine, California, Unite States.
<b>Contact Person:</b>	Scott Quon
<b>Tel:</b>	(949) 336-4398
<b>Fax:</b>	(949) 336-4804
<b>e-mail:</b>	scottquon@internationaltoy.com
<b>Manufacturer:</b>	Plastronics (Dongguan) Mfg. Ltd.
<b>Manufacturer Address:</b>	No 2, Julong Road, Shi Gu, Tang Xia, Dongguan, China
<b>Brand Name:</b>	Cars DJ RC (Car)
<b>Model:</b>	U417- HK-01003
<b>Type of EUT:</b>	Transceiver
<b>Description of EUT:</b>	DJ RC Car
<b>Serial Number:</b>	N/A
<b>FCC ID:</b>	2AIRRINT106
<b>Date of Sample Submitted:</b>	May 15, 2017
<b>Date of Test:</b>	May 15, 2017 to June 05, 2017
<b>Report No.:</b>	17050992HKG-002
<b>Report Date:</b>	June 05, 2017
<b>Environmental Conditions:</b>	Temperature: +10 to 40°C Humidity: 10 to 90%

## TEST REPORT

### SUMMARY OF TEST RESULT

TEST SPECIFICATION	REFERENCE	RESULTS
Radiated Emission	15.249, 15.209	Pass
Radiated Emission on the Bandedge		
Radiated Emission in Restricted Bands	15.205	Pass

The equipment under test is found to be complying with the following standards:  
FCC Part 15, October 1, 2015 Edition

- Note:
1. The EUT uses a permanently attached antenna which, in accordance to section 15.203, is considered sufficient to comply with the provisions of this section.
  2. Pursuant to FCC part 15 Section 15.215(c), the 20 dB bandwidth of the emission was contained within the frequency band designated (mentioned as above) which the EUT operated. The effects, if any, from frequency sweeping, frequency hopping, other modulation techniques and frequency stability over excepted variations in temperature and supply voltage were considered.

**TEST REPORT**

**TABLE OF CONTENTS**

- 1.0 GENERAL DESCRIPTION ..... 5**
  - 1.1 Product Description ..... 5
  - 1.2 Related Submittal(s) Grants ..... 5
  - 1.3 Test Methodology ..... 5
  - 1.4 Test Facility ..... 5
  
- 2.0 SYSTEM TEST CONFIGURATION ..... 6**
  - 2.1 Justification ..... 6
  - 2.2 EUT Exercising Software ..... 6
  - 2.3 Special Accessories ..... 6
  - 2.4 Measurement Uncertainty ..... 6
  - 2.5 Support Equipment List and Description ..... 6
  
- 3.0 EMISSION RESULTS ..... 7**
  - 3.1 Field Strength Calculation ..... 7
  - 3.2 Radiated Emission Configuration Photograph ..... 8
  - 3.3 Radiated Emission Data ..... 8
  
- 4.0 EQUIPMENT PHOTOGRAPHS ..... 12**
  
- 5.0 PRODUCT LABELLING ..... 12**
  
- 6.0 TECHNICAL SPECIFICATIONS ..... 12**
  
- 7.0 INSTRUCTION MANUAL ..... 12**
  
- 8.0 MISCELLANEOUS INFORMATION ..... 13**
  - 8.1 Radiated Emission on the Bandedge ..... 13
  - 8.2 Discussion of Pulse Desensitization ..... 14
  - 8.3 Calculation of Average Factor ..... 14
  - 8.4 Emissions Test Procedures ..... 16
  - 8.5 Occupied Bandwidth ..... 18
  
- 9.0 EQUIPMENT LIST ..... 19**

## TEST REPORT

### 1.0 GENERAL DESCRIPTION

#### 1.1 Product Description

The Equipment Under Test (EUT) is a portable 2.4GHz Transceiver (Car Unit) for a RC car operating at the frequency of 2407, 2445 and 2477MHz only.

The EUT is powered by 3\*1.5V AA batteries. After switching on the EUT and being paired with the controller, the car can be controlled to move forward/backward and turn left/ right by the controller.

Antenna Type: Internal, Integral

For electronic filing, the brief circuit description is saved with filename: descri.pdf.

#### 1.2 Related Submittal(s) Grants

This is a single application for certification of a transceiver.

The Certification procedure of transceiver for this transceiver (with FCC ID: 2AIRRINT107) is being processed as the same time of this application.

#### 1.3 Test Methodology

Radiated emission measurements were performed according to the procedures in ANSI C63.10 (2013). All radiated measurements were performed in an 3m Chamber. Preliminary scans were performed in the 3m Chamber only to determine worst case modes. All radiated tests were performed at an antenna to EUT distance of 3 meters, unless stated otherwise in the “**Justification Section**” of this Application.

#### 1.4 Test Facility

The 3m Chamber facility used to collect the radiated data is located at Workshop No. 3, G/F., World-Wide Industrial Centre, 43-47 Shan Mei Street, Fo Tan, Sha Tin, N.T., Hong Kong. This test facility and site measurement data have been placed on file with the FCC.

**TEST REPORT****2.0 SYSTEM TEST CONFIGURATION****2.1 Justification**

The system was configured for testing in a typical fashion (as a customer would normally use it), and in the confines as outlined in ANSI C63.10 (2013).

The device was powered by new 3 x 1.5V AA batteries.

For maximizing emissions, the EUT was rotated through 360°, the antenna height was varied from 1 meter to 4 meters above the ground plane, and the antenna polarization was changed. This step by step procedure for maximizing emissions led to the data reported in Exhibit 3.0.

The unit was operated standalone and placed in the center of the turntable.

**2.2 EUT Exercising Software**

There was no special software to exercise the device. Once the unit is powered up, it transmits the RF signal continuously.

**2.3 Special Accessories**

There are no special accessories necessary for compliance of this product.

**2.4 Measurement Uncertainty**

When determining of the test conclusion, the Measurement Uncertainty of test has been considered.

**2.5 Support Equipment List and Description**

N/A.

**TEST REPORT**

**3.0 EMISSION RESULTS**

Data is included of the worst case configuration (the configuration which resulted in the highest emission levels). A sample calculation, configuration photographs and data tables of the emissions are included.

**3.1 Field Strength Calculation**

The field strength is calculated by adding the Antenna Factor and Cable Factor, and subtracting the Amplifier Gain (if any), Average Factor (optional) from the measured reading. The basic equation with a sample calculation is as follows:

$$FS = RA + AF + CF - AG - AV$$

where FS = Field Strength in dB $\mu$ V/m

RA = Receiver Amplitude (including preamplifier) in dB $\mu$ V

CF = Cable Attenuation Factor in dB

AF = Antenna Factor in dB

AG = Amplifier Gain in dB

AV = Average Factor in dB

In the following table(s), the reading shown on the data table reflects the preamplifier gain. An example for the calculations in the following table is as follows:

$$FS = RR + LF$$

where FS = Field Strength in dB $\mu$ V/m

RR = RA - AG - AV in dB $\mu$ V

LF = CF + AF in dB

Assume a receiver reading of 52.0 dB $\mu$ V is obtained. The antenna factor of 7.4 dB and cable factor of 1.6 dB are added. The amplifier gain of 29 dB and average factor of 5 dB are subtracted, giving a field strength of 32 dB $\mu$ V/m. This value in dB $\mu$ V/m was converted to its corresponding level in  $\mu$ V/m.

$$RA = 52.0 \text{ dB}\mu\text{V/m}$$

$$AF = 7.4 \text{ dB}$$

$$CF = 1.6 \text{ dB}$$

$$AG = 29.0 \text{ dB}$$

$$AV = 5.0 \text{ dB}$$

$$FS = RR + LF$$

$$FS = 18 + 9 = 27 \text{ dB}\mu\text{V/m}$$

$$RR = 18.0 \text{ dB}\mu\text{V}$$

$$LF = 9.0 \text{ dB}$$

$$\text{Level in } \mu\text{V/m} = \text{Common Antilogarithm } [(27 \text{ dB}\mu\text{V/m})/20] = 22.4 \mu\text{V/m}$$

## TEST REPORT

### 3.2 Radiated Emission Configuration Photograph

The worst case in radiated emission was found at 4954.000 MHz

For electronic filing, the worst case radiated emission configuration photographs are saved with filename: radiated photos.pdf.

### 3.3 Radiated Emission Data

The data on the following page lists the significant emission frequencies, the limit and the margin of compliance. Numbers with a minus sign are below the limit.

Judgment: Passed by 14.1 dB



TEST REPORT

**RADIATED EMISSIONS**

Model: U417- HK-01003

Date of Test: June 05, 2017

Worst-Case Operating Mode: Transmitting

Table 1  
Pursuant to FCC Part 15 Section 15.249 Requirement

Lowest Channel

POLARI-ZATION	FREQUENCY (MHz)	READING (dBμV)	PRE-AMP GAIN (dB)	ANTENNA FACTOR (dB)	NET AT 3M - PEAK (dBμV/m)	AVERAGE FACTOR (dB)	CALCULATED AT 3M (dBμV/m)	AVERAGE LIMIT AT 3M (dBμV/m)	MARGIN (dB)
H	2407.000	91.9	33	29.4	88.3	24.1	64.2	94.0	-29.8
H	2400.000	45.1	33	29.4	41.5	24.1	17.4	54.0	-36.6
<b>H</b>	<b>4814.000</b>	<b>53.6</b>	<b>33</b>	<b>34.9</b>	<b>55.5</b>	<b>24.1</b>	<b>31.4</b>	<b>54.0</b>	<b>-22.6</b>
V	7221.000	46.8	33	37.9	51.7	24.1	27.6	54.0	-26.4

POLARI-ZATION	FREQUENCY (MHz)	READING (dBμV)	PRE-AMP GAIN (dB)	ANTENNA FACTOR (dB)	NET AT 3M - PEAK (dBμV/m)	PEAK LIMIT AT 3M (dBμV/m)	MARGIN (dB)
H	2407.000	91.9	33	29.4	88.3	114.0	-25.7
H	2400.000	45.1	33	29.4	41.5	74.0	-32.5
<b>H</b>	<b>4814.000</b>	<b>53.6</b>	<b>33</b>	<b>34.9</b>	<b>55.5</b>	<b>74.0</b>	<b>-18.5</b>
V	7221.000	46.8	33	37.9	51.7	74.0	-22.3

- NOTES:
1. Peak Detector Data unless otherwise stated.
  2. All measurements were made at 3 meters. Harmonic emissions not detected at the 3-meter distances were measured at 0.3-meter and an inverse proportional extrapolation was performed to compare the signal level to the 3-meter limit. No other harmonic emissions than those reported were detected at a test distance of 0.3-meter.
  3. Negative sign in the column shows value below limit.
  4. Horn antenna is used for the emission over 1000MHz.
  5. Emission (the row indicated by **bold italic**) within the restricted band meets the requirement of FCC Part 15 Section 15.205.
  6. Measurement Uncertainty is ±5.3dB at a level of confidence of 95%.

TEST REPORT

Model: U417- HK-01003

Date of Test: June 05, 2017

Worst-Case Operating Mode: Transmitting

Table 2  
Pursuant to FCC Part 15 Section 15.249 Requirement

Middle Channel

POLARI- ZATION	FREQUENCY (MHz)	READING (dBµV)	PRE- AMP GAIN (dB)	ANTENNA FACTOR (dB)	NET AT 3M - PEAK (dBµV/m)	AVERAGE FACTOR (dB)	CALCULATED AT 3M (dBµV/m)	AVERAGE LIMIT AT 3M (dBµV/m)	MARGIN (dB)
V	2445.000	90.6	33	29.4	87.0	24.1	62.9	94.0	-31.1
<b>H</b>	<b>4890.000</b>	<b>55.7</b>	<b>33</b>	<b>34.9</b>	<b>57.6</b>	<b>24.1</b>	<b>33.5</b>	<b>54.0</b>	<b>-20.5</b>
<b>H</b>	<b>7335.000</b>	<b>47.6</b>	<b>33</b>	<b>37.9</b>	<b>52.5</b>	<b>24.1</b>	<b>28.4</b>	<b>54.0</b>	<b>-25.6</b>

POLARI- ZATION	FREQUENCY (MHz)	READING (dBµV)	PRE-AMP GAIN (dB)	ANTENNA FACTOR (dB)	NET AT 3M - PEAK (dBµV/m)	PEAK LIMIT AT 3M (dBµV/m)	MARGIN (dB)
V	2445.032	90.6	33	29.4	87.0	114.0	-27.0
<b>H</b>	<b>4890.064</b>	<b>55.7</b>	<b>33</b>	<b>34.9</b>	<b>57.6</b>	<b>74.0</b>	<b>-16.4</b>
<b>H</b>	<b>7335.064</b>	<b>47.6</b>	<b>33</b>	<b>37.9</b>	<b>52.5</b>	<b>74.0</b>	<b>-21.5</b>

- NOTES:
1. Peak Detector Data unless otherwise stated.
  2. All measurements were made at 3 meters. Harmonic emissions not detected at the 3-meter distances were measured at 0.3-meter and an inverse proportional extrapolation was performed to compare the signal level to the 3-meter limit. No other harmonic emissions than those reported were detected at a test distance of 0.3-meter.
  3. Negative sign in the column shows value below limit.
  4. Horn antenna is used for the emission over 1000MHz.
  5. Emission (the row indicated by **bold italic**) within the restricted band meets the requirement of FCC Part 15 Section 15.205.
  6. Measurement Uncertainty is ±5.3dB at a level of confidence of 95%.

TEST REPORT

Model: U417- HK-01003

Date of Test: June 05, 2017

Worst-Case Operating Mode: Transmitting

Table 3  
Pursuant to FCC Part 15 Section 15.249 Requirement

Highest Channel

POLARI-ZATION	FREQUENCY (MHz)	READING (dBμV)	PRE-AMP GAIN (dB)	ANTENNA FACTOR (dB)	NET AT 3M - PEAK (dBμV/m)	AVERAGE FACTOR (dB)	CALCULATED AT 3M (dBμV/m)	AVERAGE LIMIT AT 3M (dBμV/m)	MARGIN (dB)
V	2477.000	92.7	33	29.4	89.1	24.1	65.0	94.0	-29.0
V	<b>2483.500</b>	<b>47.7</b>	<b>33</b>	<b>29.4</b>	<b>44.1</b>	<b>24.1</b>	<b>20.0</b>	<b>54.0</b>	<b>-34.0</b>
V	<b>4954.000</b>	<b>58.0</b>	<b>33</b>	<b>34.9</b>	<b>59.9</b>	<b>24.1</b>	<b>35.8</b>	<b>54.0</b>	<b>-18.2</b>
V	<b>7431.000</b>	<b>47.8</b>	<b>33</b>	<b>37.9</b>	<b>52.7</b>	<b>24.1</b>	<b>28.6</b>	<b>54.0</b>	<b>-25.4</b>

POLARI-ZATION	FREQUENCY (MHz)	READING (dBμV)	PRE-AMP GAIN (dB)	ANTENNA FACTOR (dB)	NET AT 3M - PEAK (dBμV/m)	PEAK LIMIT AT 3M (dBμV/m)	MARGIN (dB)
V	2477.000	92.7	33	29.4	89.1	114.0	-24.9
V	<b>2483.500</b>	<b>47.7</b>	<b>33</b>	<b>29.4</b>	<b>44.1</b>	<b>74.0</b>	<b>-29.9</b>
V	<b>4954.000</b>	<b>58.0</b>	<b>33</b>	<b>34.9</b>	<b>59.9</b>	<b>74.0</b>	<b>-14.1</b>
V	<b>7431.000</b>	<b>47.8</b>	<b>33</b>	<b>37.9</b>	<b>52.7</b>	<b>74.0</b>	<b>-21.3</b>

- NOTES:
1. Peak Detector Data unless otherwise stated.
  2. All measurements were made at 3 meters. Harmonic emissions not detected at the 3-meter distances were measured at 0.3-meter and an inverse proportional extrapolation was performed to compare the signal level to the 3-meter limit. No other harmonic emissions than those reported were detected at a test distance of 0.3-meter.
  3. Negative sign in the column shows value below limit.
  4. Horn antenna is used for the emission over 1000MHz.
  5. Emission (the row indicated by **bold italic**) within the restricted band meets the requirement of FCC Part 15 Section 15.205.
  6. Measurement Uncertainty is ±5.3dB at a level of confidence of 95%.

**TEST REPORT****4.0 EQUIPMENT PHOTOGRAPHS**

For electronic filing, the photographs are saved with filename: external photos.pdf and internal photos.pdf.

**5.0 PRODUCT LABELLING**

For electronics filing, the FCC ID label artwork and the label location are saved with filename: label.pdf.

**6.0 TECHNICAL SPECIFICATIONS**

For electronic filing, the block diagram and schematic of the tested EUT are saved with filename: block.pdf and circuit.pdf respectively.

**7.0 INSTRUCTION MANUAL**

For electronic filing, a preliminary copy of the Instruction Manual is saved with filename: manual.pdf.

This manual will be provided to the end-user with each unit sold/leased in the United States.

**TEST REPORT****8.0 MISCELLANEOUS INFORMATION**

The miscellaneous information includes details of the test procedure and measured bandwidth / calculation of factor such as pulse desensitization and averaging factor (calculation and timing diagram).

**8.1 Radiated Emission on the Bandedge**

From the following plots, they show that the fundamental emissions are confined in the specified band (2400MHz to 2483.5MHz). In case of the fundamental emissions are within two standard bandwidths from the bandedge, the delta measurement technique is used for determining bandedge compliance. Standard bandwidth is the bandwidth specified by ANSI C63.10 (2013) for frequency being measured.

Emissions radiated outside of the specified frequency bands, except harmonics, are attenuated by 50dB below the level of the fundamental or to the general radiated emissions limits in Section 15.209 , whichever is the lesser attenuation, which meet the requirement of part 15.249(d).

## TEST REPORT

### Peak Measurement

The test data of bandedge emissions were shown on the above radiated emissions table 1 & table 3 respectively.

The resultant field strength meets the general radiated emission limit in section 15.209, which does not exceed 74 dB $\mu$ V/m (Peak Limit) but exceeded 54 dB $\mu$ V/m (Average Limit).

### 8.2 Discussion of Pulse Desensitization

Pulse desensitivity is not applicable for this device. The effective period (Teff) is approximately 0.48ms for a digital "1" bit which illustrated on technical specification, with a resolution bandwidth (3dB) of 1MHz, so the pulse desensitivity factor is 0dB.

### 8.3 Calculation of Average Factor

The duty cycle is simply the on-time divided by the period:

The duration of one cycle = 100 ms

Effective period of the cycle = 13 \* 0.48 = 6.24 ms

DC = 6.24/100 = 0.0624

Therefore, the averaging factor is found by  $20\log 0.0624 = -24.1\text{dB}$ .

## TEST REPORT

### Average Factor

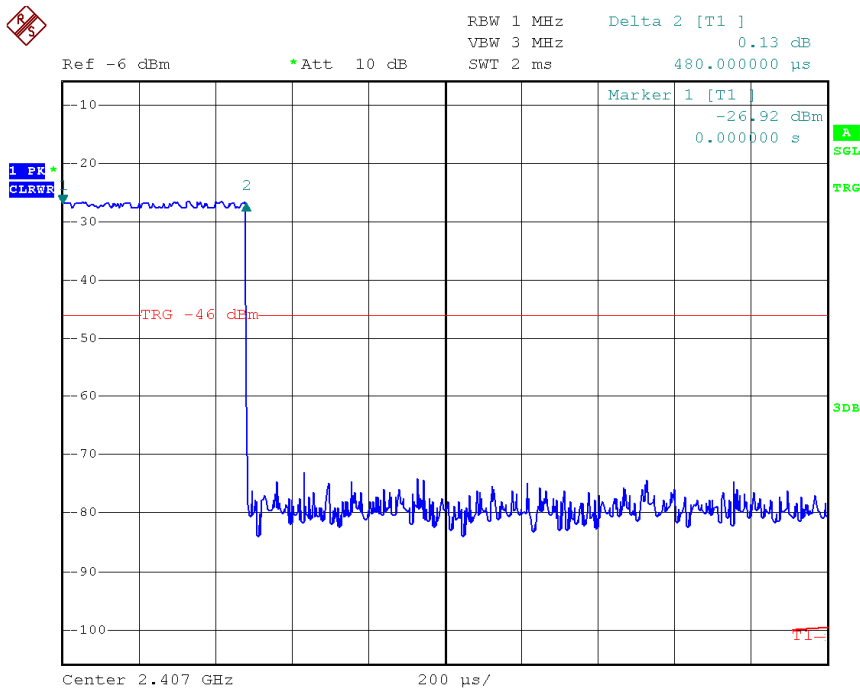
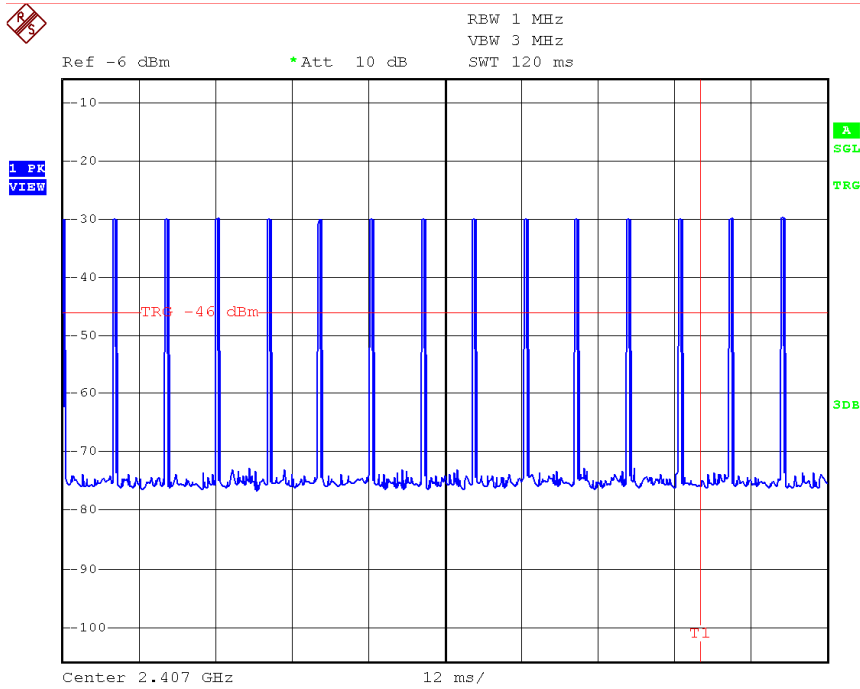

## TEST REPORT

### 8.4 Emissions Test Procedures

The following is a description of the test procedure used by Intertek Testing Services Hong Kong Ltd. in the measurements of transmitter operating under the Part 15, Subpart C rules.

The transmitting equipment under test (EUT) is placed on a wooden turntable which is four feet in diameter and approximately 0.8m in height above the ground plane for emission measurement at or below 1GHz and 1.5m in height above the ground plane for emission measurement above 1GHz. During the radiated emissions test, the turntable is rotated and any cables leaving the EUT are manipulated to find the configuration resulting in maximum emissions. The EUT is adjusted through all three orthogonal axis to obtain maximum emission levels. The antenna height and polarization are also varied during the testing to search for maximum signal levels. The height of the antenna is varied from one to four meters.

Detector function for radiated emissions is in peak mode. Average readings, when required, are taken by measuring the duty cycle of the equipment under test and subtracting the corresponding amount in dB from the measured peak readings. A detailed description for the calculation of the average factor can be found in Exhibit 8.3.

The frequency range scanned is from the lowest radio frequency signal generated in the device which is greater than 9 kHz to the tenth harmonic of the highest fundamental frequency or 40 GHz, whichever is lower.



## TEST REPORT

### 8.4 Emissions Test Procedures (cont'd)

The EUT is warmed up for 15 minutes prior to the test.

AC power to the unit is varied from 85% to 115% nominal and variation in the fundamental emission field strength is recorded. If battery powered, a new, fully charged battery is used.

Conducted measurements were made as described in ANSI C63.10 (2013).

The IF bandwidth used for measurement of radiated signal strength was 100 kHz or greater when frequency is below 1000 MHz. Where pulsed transmissions of short enough pulse duration warrant, a greater bandwidth is selected according to the recommendations of Hewlett Packard Application Note 150-2. A discussion of whether pulse desensitivity is applicable to this unit is included in this report (See Exhibit 8.1). Above 1000 MHz, a resolution bandwidth of 1 MHz is used.

Transmitter measurements are normally conducted at a measurement distance of three meters. However, to assure low enough noise floor in the forbidden bands and above 1 GHz, signals are acquired at a distance of one meter or less. All measurements are extrapolated to three meters using inverse scaling, unless otherwise reported. Measurements taken at a closer distance are so marked.

**TEST REPORT**

8.4.1 Radiated Emission Test Setup

The figure below shows the test setup, which is utilized to make these measurements.

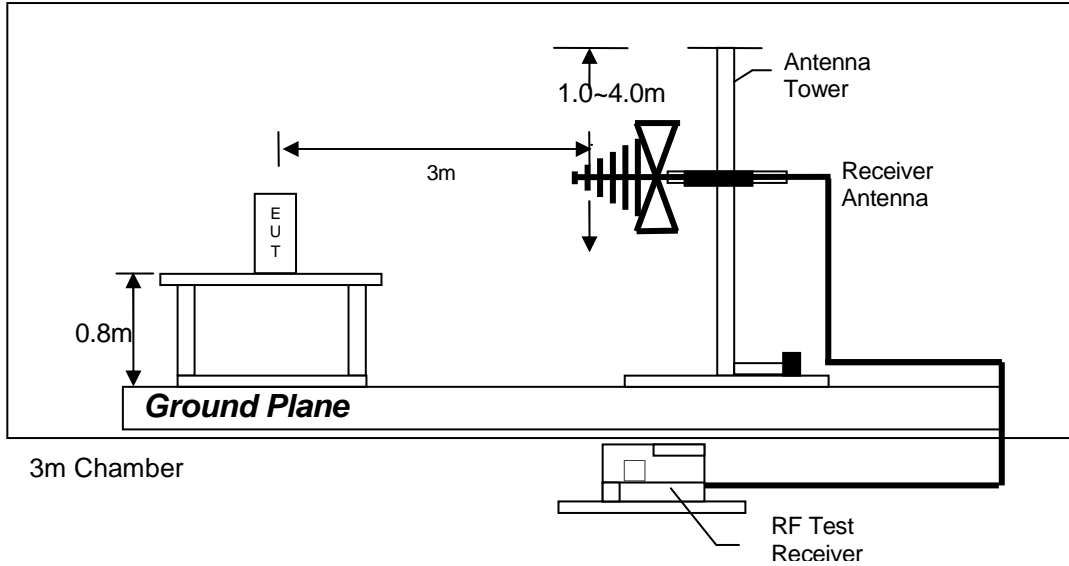

Test setup of radiated emissions up to 1GHz

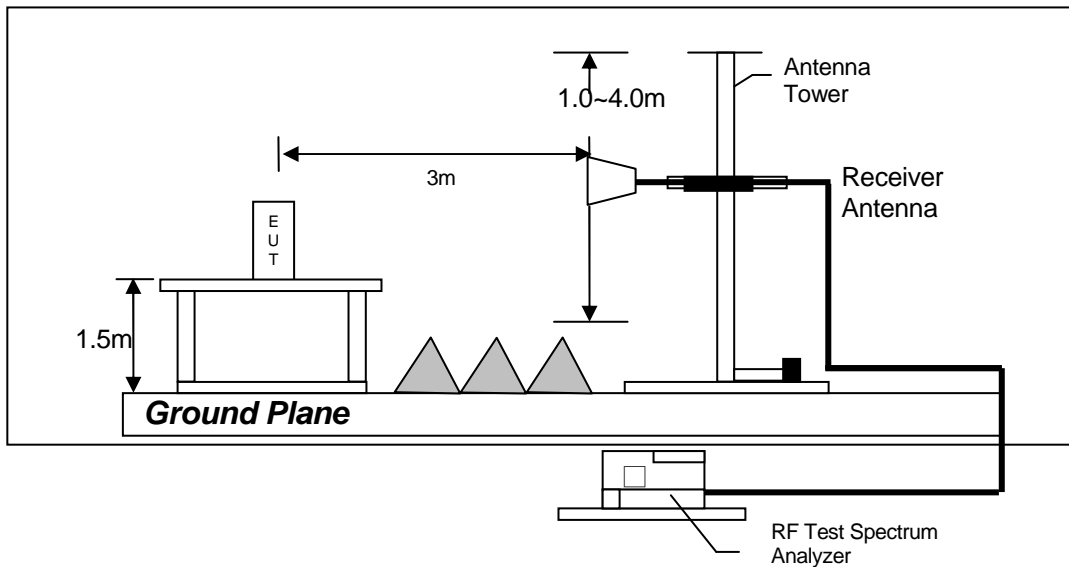

Test setup of radiated emissions above 1GHz

**TEST REPORT**

**9.0 EQUIPMENT LIST**

1) Radiated Emissions Test

<b>EQUIPMENT</b>	<b>EMI Test Receiver</b>	<b>Spectrum Analyzer</b>	<b>Double Ridged Guide Antenna</b>
Registration No.	EW-3156	EW-2466	EW-0194
Manufacturer	R&S	R&S	EMCO
Model No.	ESR26	FSP30	3115
Calibration Date	Dec. 06, 2016	Oct. 03, 2016	Aug. 10, 2016
Calibration Due Date	Dec. 06, 2017	Jun. 15, 2017	Feb. 10, 2018

<b>EQUIPMENT</b>	<b>Pyramidal Horn Antenna</b>	<b>Biconical Antenna</b>	<b>Log Periodic Antenna</b>
Registration No.	EW-0905	EW-0571	EW-0447
Manufacturer	EMCO	EMCO	EMCO
Model No.	3160-09	3104C	3146
Calibration Date	Feb. 12, 2016	May 18, 2016	May 18, 2016
Calibration Due Date	Aug. 12, 2017	Nov. 18, 2017	Nov. 18, 2017

2) Bandwidth and Average Factor Measurement

<b>EQUIPMENT</b>	<b>SPECTRUM ANALYZER</b>
Registration No.	EW-2329
Manufacturer	R&S
Model No.	FSP3
Calibration Date	Aug. 26, 2016
Calibration Due Date	Aug. 26, 2017

END OF TEST REPORT