

## FCC&ISED RF TEST REPORT

**No. 171200800SHA-003**

Applicant : Snap Inc.  
63 Market Street, Venice, CA 90291, USA

Product Name : Wearable video camera

Type/Model : 002

**TEST RESULT : PASS**

### SUMMARY

The equipment complies with the requirements according to the following standard(s) or specification:

**47CFR Part 15 (2016):** Radio Frequency Devices (Subpart C)

**ANSI C63.10 (2013):** American National Standard of Procedures for Compliance Testing of Unlicensed Wireless Devices

**RSS-247 Issue 2 (February 2017):** Digital Transmission Systems (DTSS), Frequency Hopping Systems (FHSs) and Licence-Exempt Local Area Network (LE-LAN) Devices

**RSS-Gen Issue 4 (November 2014):** General Requirements for Compliance of Radio Apparatus

Date of issue: March 2, 2018

Prepared by:



Wade Zhang (Project engineer)

Reviewed by:

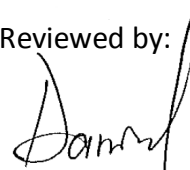

Daniel Zhao (Reviewer)

## Content

<b>SUMMARY .....</b>	<b>1</b>
<b>REVISION HISTORY .....</b>	<b>4</b>
<b>1 GENERAL INFORMATION .....</b>	<b>5</b>
1.1 IDENTIFICATION OF THE EUT .....	5
1.2 TECHNICAL SPECIFICATION.....	5
1.3 DESCRIPTION OF TEST FACILITY .....	6
<b>2 TEST SPECIFICATIONS .....</b>	<b>7</b>
2.1 STANDARDS OR SPECIFICATION .....	7
2.2 MODE OF OPERATION DURING THE TEST.....	7
2.3 TEST SOFTWARE LIST.....	8
2.4 TEST PERIPHERALS LIST.....	8
2.5 INSTRUMENT LIST.....	9
2.6 TEST SUMMARY.....	10
2.7 MEASUREMENT UNCERTAINTY .....	11
<b>3 MINIMUM 6DB BANDWIDTH .....</b>	<b>12</b>
3.1 LIMIT.....	12
3.2 TEST CONFIGURATION.....	12
3.3 TEST PROCEDURE AND TEST SETUP.....	12
3.4 TEST PROTOCOL.....	13
<b>4 MAXIMUM CONDUCTED OUTPUT POWER.....</b>	<b>16</b>
4.1 TEST LIMIT.....	16
4.2 TEST CONFIGURATION.....	16
4.3 TEST PROCEDURE AND TEST SETUP .....	16
4.4 TEST PROTOCOL .....	17
<b>5 POWER SPECTRUM DENSITY .....</b>	<b>20</b>
5.1 TEST LIMIT.....	20
5.2 TEST CONFIGURATION.....	20
5.3 TEST PROCEDURE AND TEST SETUP .....	21
5.4 TEST PROTOCOL.....	22
<b>6 EMISSION OUTSIDE THE FREQUENCY BAND.....</b>	<b>25</b>
6.1 TEST LIMIT.....	25
6.2 TEST CONFIGURATION.....	25
6.3 TEST PROCEDURE AND TEST SETUP .....	26
6.4 TEST PROTOCOL.....	27
<b>7 RADIATED EMISSIONS .....</b>	<b>39</b>
7.1 TEST LIMIT.....	39
7.2 TEST CONFIGURATION.....	39
7.3 TEST PROCEDURE AND TEST SETUP .....	40
7.4 TEST PROTOCOL.....	41
<b>8 POWER LINE CONDUCTED EMISSION .....</b>	<b>45</b>
8.1 LIMIT.....	45
8.2 TEST CONFIGURATION .....	45
8.3 TEST PROCEDURE AND TEST SET UP .....	46
8.4 TEST PROTOCOL .....	47

**9 OCCUPY BANDWIDTH..... 49**

9.1 LIMIT..... 49

9.2 TEST CONFIGURATION..... 49

9.3 TEST PROCEDURE AND TEST SETUP..... 49

9.4 TEST PROTOCOL..... 50

**ANNEX: DUTY CYCLE..... 53**

## Revision History

Issue No.	Version	Description	Date Issued
171200800SHA-003	Rev. 01	Initial issue of report	March 2, 2018

## 1 GENERAL INFORMATION

### 1.1 Identification of the EUT

Product Name : Wearable video camera  
Type/model : 002  
FCC ID : 2AIRN-002  
IC : 22922-002

### 1.2 Technical Specification

Operation Frequency : 2400~2483.5 MHz  
Band  
Type of Modulation : DBPSK, DQPSK, CCK, BPSK, QPSK, 16-QAM, 64-QAM  
EUT Modes of Modulation : 802.11b, 802.11g, 802.11n(HT20), 802.11n(HT40)  
Channel Number : 11 Channels for 802.11b, 802.11g and 802.11n(HT20)  
9 Channels for 802.11n(HT40)

Description of EUT : The EUT is a wearable video camera which support WIFI and Bluetooth 4.2 technology, there have only one mode, we tested it and listed the WIFI 2.4GHz band result in this report.

Antenna : Internal Monopole antenna, 4.2dBi Peak gain  
Rating : DC 5V  
Category of EUT : Class B  
EUT type :  Table top  
 Floor standing

Sample received date : December 12, 2017  
Date of test : December 12, 2017 ~ January 10, 2018

**Antenna Requirement:** An intentional radiator shall be designed to ensure that no antenna other than that furnished by the responsible party shall be used with the device. The use of a permanently attached antenna or of an antenna that uses a unique coupling to the intentional radiator shall be considered sufficient to comply with the provisions of this section. The manufacturer may design the unit so that a broken antenna can be replaced by the user, but the use of a standard antenna jack or electrical connector is prohibited.

**The EUT used an internal monopole antenna and used a no-standard electrical connector, so fulfill these requirements.**

### 1.3 Description of Test Facility

Name : Intertek Testing Services Shanghai  
Address : Building 86, No. 1198 Qinzhou Road(North), Shanghai 200233, P.R. China  
Telephone : 86 21 61278200  
Telefax : 86 21 54262353

The test facility is recognized, certified, or accredited by these organizations :

- CNAS Accreditation Lab  
Registration No. CNAS L0139
- FCC Accredited Lab  
Designation Number: CN1175
- IC Registration Lab  
Registration code No.: 2042B-1
- VCCI Registration Lab  
Registration No.: R-4243, G-845, C-4723, T-2252
- NVLAP Accreditation Lab  
NVLAP LAB CODE: 200849-0
- A2LA Accreditation Lab  
Certificate Number: 3309.02

## 2 TEST SPECIFICATIONS

### 2.1 Standards or specification

47CFR Part 15 (2016)  
ANSI C63.10 (2013)  
RSS-247 Issue 2 (February 2017)  
RSS-Gen Issue 4 (November 2014)  
KDB 558074 (v04)

### 2.2 Mode of operation during the test

While testing transmitting mode of EUT, the internal modulation and continuously transmission was applied.

The lowest, middle and highest channel were tested as representatives.

Frequency Band (MHz)	Mode	Lowest (MHz)	Middle (MHz)	Highest (MHz)
2400-2483.5	802.11b	2412	2437	2462
	802.11g	2412	2437	2462
	802.11n(HT20)	2412	2437	2462
	802.11n(HT40)	2422	2437	2452

#### Data rate VS Power:

The pre-scan for the conducted power with all rates in each modulation and bands was used, and the worst case was found and used in all test cases. After this pre-scan, we choose the following table of the data rate as the worst case.

Frequency Band (MHz)	Mode	Worst case data rate
2400-2483.5	802.11b	1Mbps
	802.11g	6Mbps
	802.11n(HT20)	MCS0
	802.11n(HT40)	MCS0

The EUT will use two types antenna, and there have the following test mode:

Radiated test mode:

Mode 1: EUT transmitted signal with internal antenna;

Conducted test mode:

Mode 2: EUT transmitted signal from PCBA RF port connected to SPA directly;

We have verified all test modes, and choose the worst mode 1 for radiated test and mode 2 for conducted test as representatively to list the results in this report.

### 2.3 Test software list

Test Items	Software	Manufacturer	Version
Conducted emission	ESxS-K1	R&S	V2.1.0
Radiated emission	ES-K1	R&S	V1.71

### 2.4 Test peripherals list

Item No.	Name	Band and Model	Description
1	Laptop computer	HP ProBook 6470b	100-240V AC, 50/60Hz FCC DOC
2	AC-DC adaptor	KA25	100-240VAC, DC5V1A FCC VOC
3	RF Board	NA	NA



## 2.5 Instrument list

Conducted Emission					
Used	Equipment	Manufacturer	Type	Internal no.	Due date
<input checked="" type="checkbox"/>	Test Receiver	R&S	ESCS 30	EC 2107	2018-10-18
<input checked="" type="checkbox"/>	A.M.N.	R&S	ESH2-Z5	EC 3119	2018-12-01
<input checked="" type="checkbox"/>	Shielded room	Zhongyu	-	EC 2838	2019-01-08
Radiated Emission					
Used	Equipment	Manufacturer	Type	Internal no.	Due date
<input checked="" type="checkbox"/>	Test Receiver	R&S	ESIB 26	EC 3045	2018-10-18
<input checked="" type="checkbox"/>	Bilog Antenna	TESEQ	CBL 6112D	EC 4206	2018-05-30
<input checked="" type="checkbox"/>	Horn antenna	R&S	HF 906	EC 3049	2018-09-22
<input checked="" type="checkbox"/>	Horn antenna	ETS	3117	EC 4792-1	2018-08-23
<input checked="" type="checkbox"/>	Horn antenna	TOYO	HAP18-26W	EC 4792-3	2020-07-09
<input checked="" type="checkbox"/>	Pre-amplifier	R&S	Pre-amp 18	EC5881	2018-06-19
<input checked="" type="checkbox"/>	Semi-anechoic chamber	Albatross project	-	EC 3048	2018-09-08
RF test					
Used	Equipment	Manufacturer	Type	Internal no.	Due date
<input checked="" type="checkbox"/>	PXA Signal Analyzer	Keysight	N9030A	EC 5338	2018-09-10
<input checked="" type="checkbox"/>	Power sensor	Agilent	U2021XA	EC 5338-1	2018-03-03
<input checked="" type="checkbox"/>	Vector Signal Generator	Agilent	N5182B	EC 5175	2018-03-06
<input checked="" type="checkbox"/>	MXG Analog Signal Generator	Agilent	N5181A	EC 5338-2	2018-03-03
<input checked="" type="checkbox"/>	Mobile Test System	Litepoint	lqxel	EC 5176	2019-01-11
<input checked="" type="checkbox"/>	Test Receiver	R&S	ESCI 7	EC 4501	2018-02-23
Additional instrument					
Used	Equipment	Manufacturer	Type	Internal no.	Due date
<input checked="" type="checkbox"/>	Therom-Hygrograph	ZJ1-2A	S.M.I.F.	EC 3323	2018-06-14
<input checked="" type="checkbox"/>	Therom-Hygrograph	ZJ1-2A	S.M.I.F.	EC 3324	2018-04-09
<input checked="" type="checkbox"/>	Therom-Hygrograph	ZJ1-2A	S.M.I.F.	EC 3325	2018-03-23
<input checked="" type="checkbox"/>	Pressure meter	YM3	Shanghai Mengde	EC 3320	2018-06-28

## 2.6 Test Summary

This report applies to tested sample only. The test results have been compared directly with the limits, and the measurement uncertainty is recorded. This report shall not be reproduced in part without written approval of Intertek Testing Service Shanghai Limited.

TEST ITEM	FCC REFERANCE	IC REFERANCE	RESULT
Minimum 6dB Bandwidth & Occupied bandwidth	15.247(a)(2)	RSS-247 Issue 2 Clause 5.2	Pass
Maximum peak output power	15.247(b)	RSS-247 Issue 2 Clause 5.4	Pass
Power spectrum density	15.247(e)	RSS-247 Issue 2 Clause 5.2	Pass
Radiated emission	15.205 & 15.209	RSS-247 Issue 2 Clause 5.5	Pass
Emission outside the frequency band	15.247(d)	RSS-Gen Issue 4 Clause 8.9	Pass
Power line conducted emission	15.207	RSS-Gen Issue 4 Clause 8.8	Pass
Occupied bandwidth	-	RSS-Gen Issue 4 Clause 6.6	Tested

Notes: 1: NA =Not Applicable

2: This report is for the exclusive use of Intertek's Client and is provided pursuant to the agreement between Intertek and its Client. Intertek's responsibility and liability are limited to the terms and conditions of the agreement. Intertek assumes no liability to any party, other than to the Client in accordance with the agreement, for any loss, expense or damage occasioned by the use of this report. Only the Client is authorized to permit copying or distribution of this report and then only in its entirety. Any use of the Intertek name or one of its marks for the sale or advertisement of the tested material, product or service must first be approved in writing by Intertek. The observations and test results in this report are relevant only to the sample tested. This report by itself does not imply that the material, product, or service is or has ever been under an Intertek certification program.

## 2.7 Measurement uncertainty

The measurement uncertainty represents an expanded uncertainty expressed at approximately the 95% confidence level using a coverage factor of k=2.

Test item	Measurement uncertainty
Maximum peak output power	± 0.74dB
Radiated Emissions in restricted frequency bands below 1GHz	± 4.90dB
Radiated Emissions in restricted frequency bands above 1GHz	± 5.02dB
Emission outside the frequency band	± 2.89dB
Power line conducted emission	± 3.19dB

### 3 Minimum 6dB Bandwidth

Test result: Pass

#### 3.1 Limit

For systems using digital modulation techniques that may operate in the 902 - 928 MHz, 2400 - 2483.5 MHz and 5725 - 5850 MHz bands, the minimum 6 dB bandwidth shall be at least 500 kHz.

#### 3.2 Test Configuration

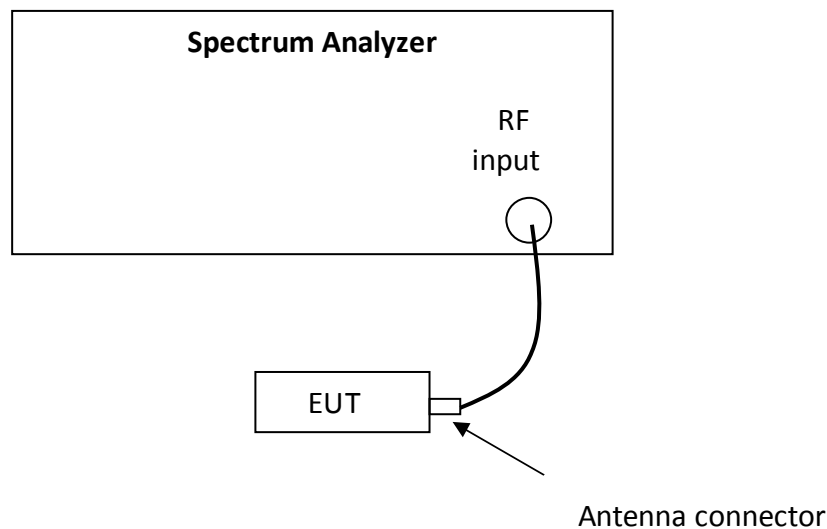

#### 3.3 Test Procedure and test setup

The minimum 6dB bandwidth per FCC §15.247(a)(2) is measured using the Spectrum Analyzer according to DTS test procedure of "KDB558074 D01 DTS Meas Guidance" for compliance to FCC 47CFR 15.247 requirements (clause 8.2).

- a) Set RBW = 100 kHz.
- b) Set the video bandwidth (VBW)  $\geq 3 \times$  RBW.
- c) Detector = Peak.
- d) Trace mode = max hold.
- e) Sweep = auto couple.
- f) Allow the trace to stabilize.
- g) Measure the maximum width of the emission that is constrained by the frequencies associated with the two outermost amplitude points (upper and lower frequencies) that are attenuated by 6 dB relative to the maximum level measured in the fundamental emission.

### 3.4 Test Protocol

Temperature: 25 °C  
Relative Humidity: 55 %

WLAN Occupied 6dB Bandwidth				
Mode	Test Frequency(MHz)	Ant	Occupied Bandwidth(MHz)	Result
802.11b	2412	Ant1	8.08	Pass
802.11b	2437	Ant1	8.07	Pass
802.11b	2462	Ant1	8.07	Pass
802.11g	2412	Ant1	15.17	Pass
802.11g	2437	Ant1	15.18	Pass
802.11g	2462	Ant1	15.16	Pass
802.11n(HT20)	2412	Ant1	15.13	Pass
802.11n(HT20)	2437	Ant1	15.16	Pass
802.11n(HT20)	2462	Ant1	15.18	Pass
802.11n(HT40)	2422	Ant1	35.13	Pass
802.11n(HT40)	2437	Ant1	35.17	Pass
802.11n(HT40)	2452	Ant1	35.15	Pass

Test Plots:

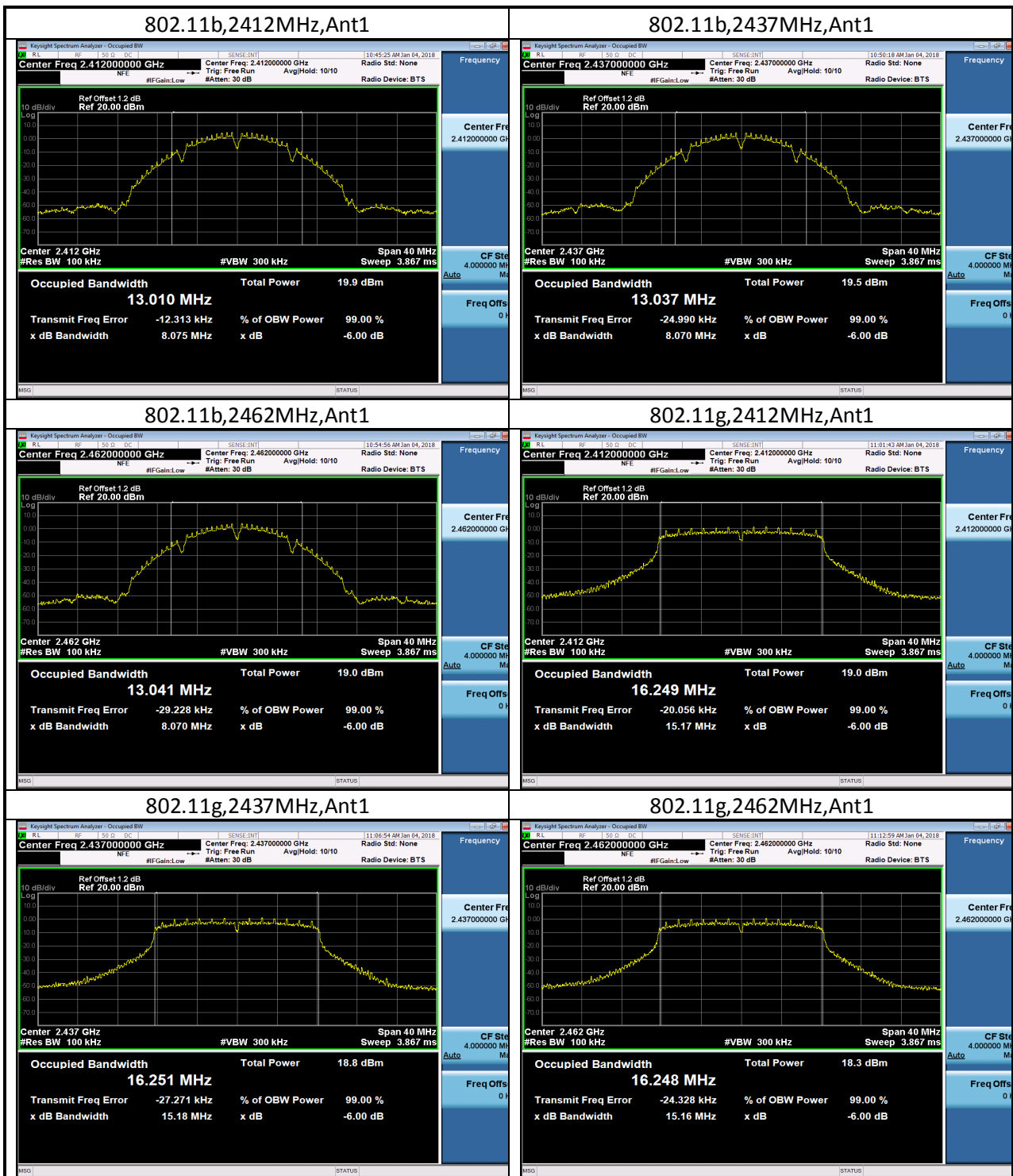

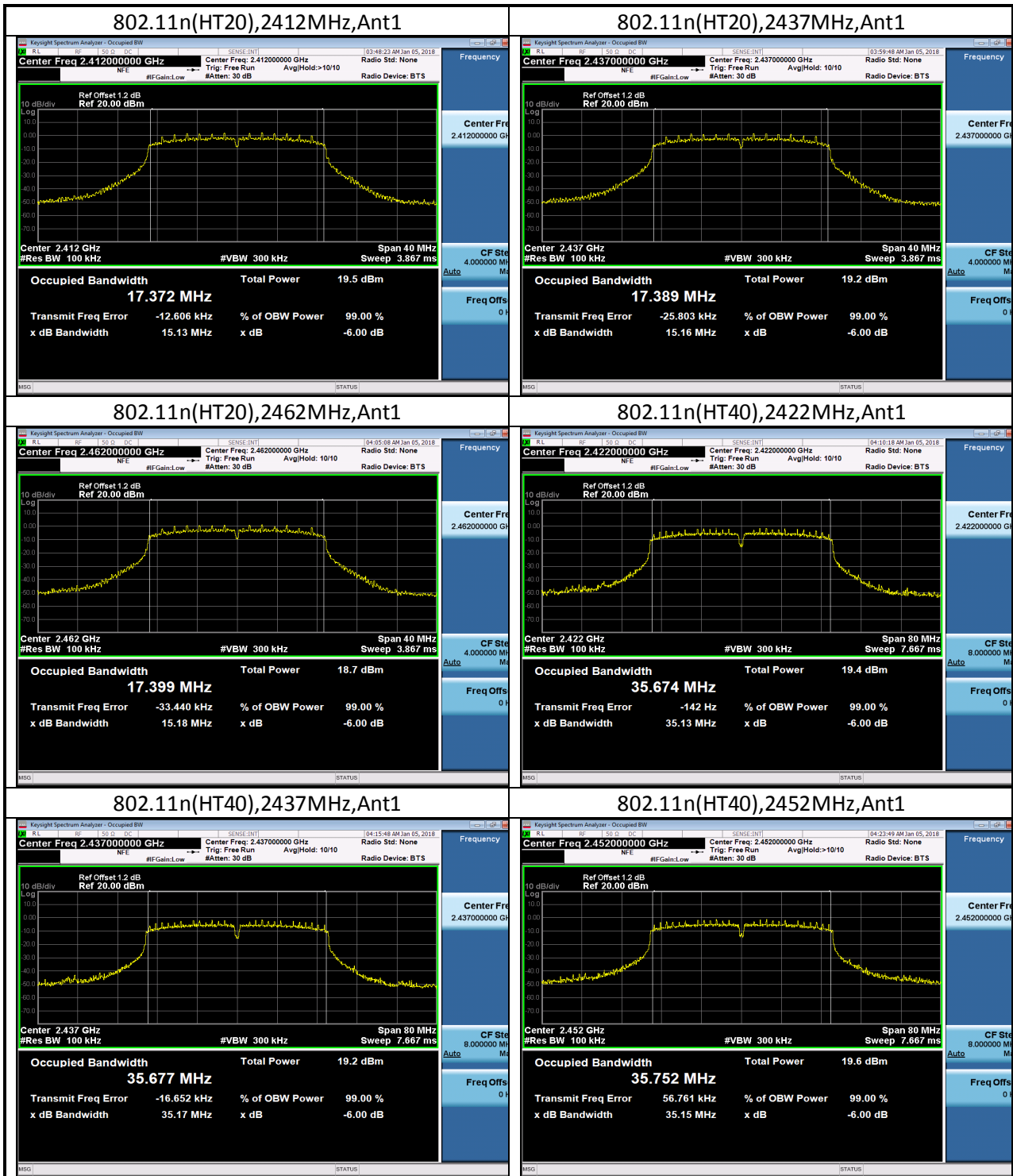

## 4 Maximum Conducted Output power

Test result: Pass

### 4.1 Test limit

- For frequency hopping systems operating in the 2400-2483.5 MHz band employing at least 75 non-overlapping hopping channels, and all frequency hopping systems in the 5725-5850 MHz band: 1 watt
- For all other frequency hopping systems in the 2400-2483.5 MHz band: 0.125 watts
- For systems using digital modulation in the 902-928 MHz, 2400-2483.5 MHz, and 5725-5850 MHz bands: 1 Watt and the e.i.r.p. shall not exceed 4 W.

If the transmitting antenna of directional gain greater than 6dBi is used, the power shall be reduced by the amount in dB that the directional gain of the antenna exceeds 6dBi. If there have a beam forming type, the limit should be the minimum of 30dBm and 30+ (6 –antenna gain-beam forming gain).

### 4.2 Test Configuration

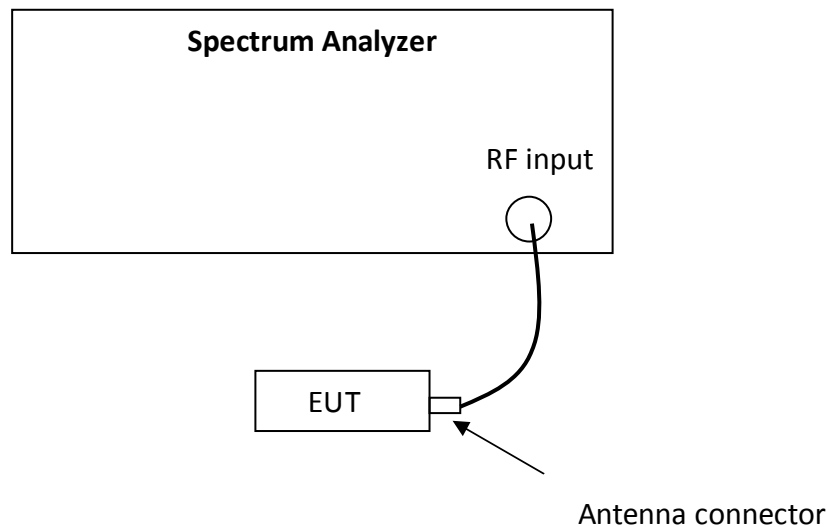

### 4.3 Test procedure and test setup

The EUT was tested according to DTS test procedure of "KDB558074 D01 DTS Meas Guidance" for compliance to FCC 47CFR 15.247 requirements (9.2.2.4 Method AVGSA-2 (trace averaging across on- and off-times of the EUT transmissions, followed by duty cycle correction)).



#### 4.4 Test protocol

Temperature: 25 °C

Relative Humidity: 55 %

WLAN AVGSA Output Power							
Mode	Test Frequency(MHz)	Ant	Duty Cycle Factor (dB)	Max Power (dBm)	Limit (dBm)	EIRP (dBm)	Result
802.11b	2412	Ant1	0.00	<b>12.65</b>	30	<b>16.85</b>	Pass
802.11b	2437	Ant1	0.00	12.30	30	16.50	Pass
802.11b	2462	Ant1	0.00	11.84	30	16.04	Pass
802.11g	2412	Ant1	0.26	11.79	30	15.99	Pass
802.11g	2437	Ant1	0.24	11.56	30	15.76	Pass
802.11g	2462	Ant1	0.24	11.13	30	15.33	Pass
802.11n(HT20)	2412	Ant1	0.38	12.15	30	16.35	Pass
802.11n(HT20)	2437	Ant1	0.37	11.93	30	16.13	Pass
802.11n(HT20)	2462	Ant1	0.29	11.41	30	15.61	Pass
802.11n(HT40)	2422	Ant1	0.72	12.13	30	16.33	Pass
802.11n(HT40)	2437	Ant1	0.47	11.62	30	15.82	Pass
802.11n(HT40)	2452	Ant1	0.54	12.35	30	16.55	Pass

**NOTE:**

*Max Power (dBm) = Corrected Reading(dBm) + Factor(dB);*

*Factor(dB) = 10\*log (1/duty cycle (%)/100).*

**Conclusion:** The maximum EIRP = 12.65dBm+4.2dBi = 16.85dBm = 0.048W which is lower than the limit of 4W listed in RSS-247.

Test Plots:

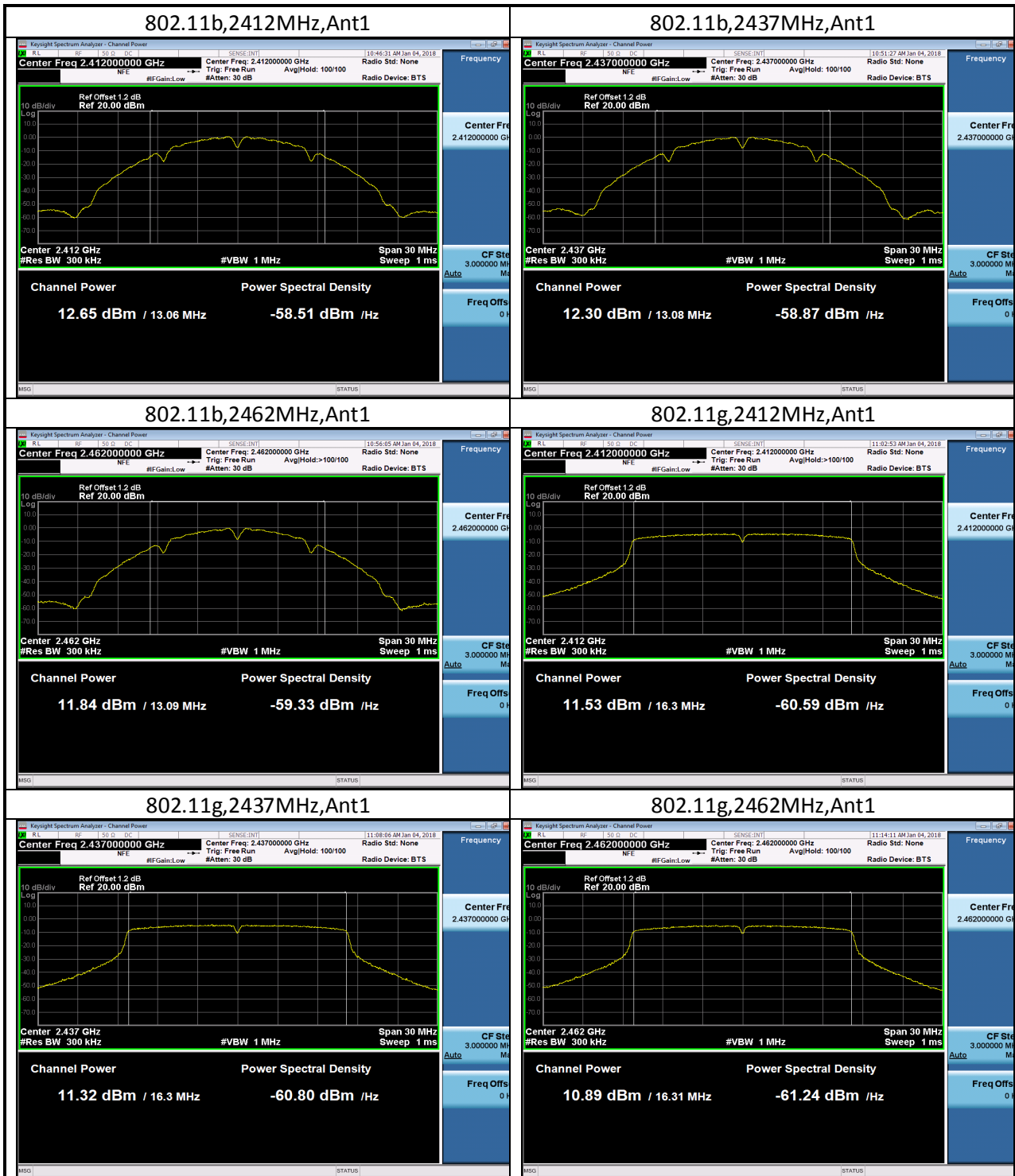

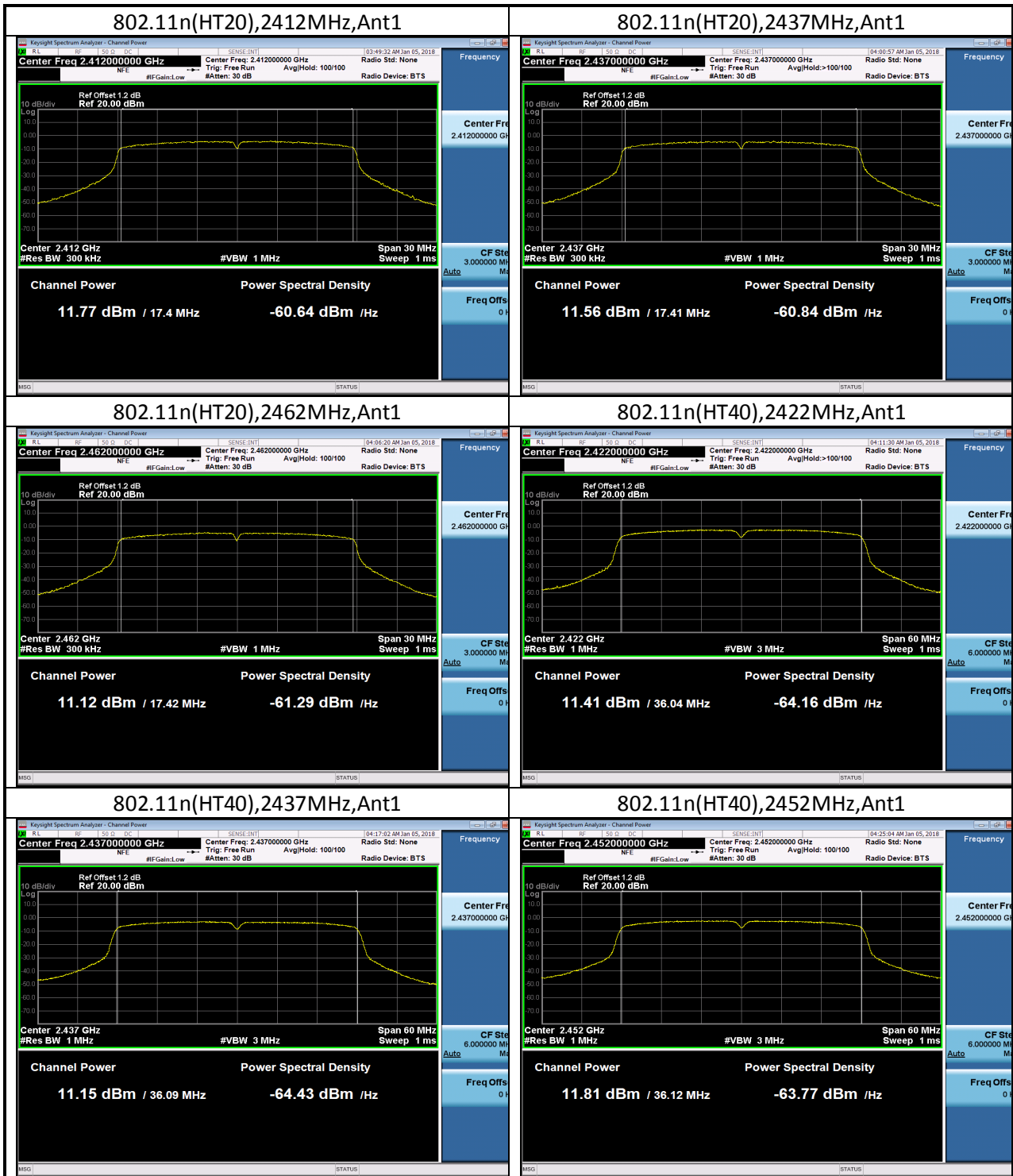

## 5 Power spectrum density

**Test result:Pass**

### 5.1 Test limit

For digitally modulated systems, the power spectral density conducted from the intentional radiator to the antenna shall not be greater than 8dBm in any 3kHz band during any time interval of continuous transmission.

If the transmitting antenna of directional gain greater than 6dBi is used, the power shall be reduced by the amount in dB that the directional gain of the antenna exceeds 6dBi. If there have a beam forming type, the limit should be the minimum of 8dBm/3kHz and  $8 + (6 - \text{antenna gain} - \text{beam forming gain})$ .

### 5.2 Test Configuration

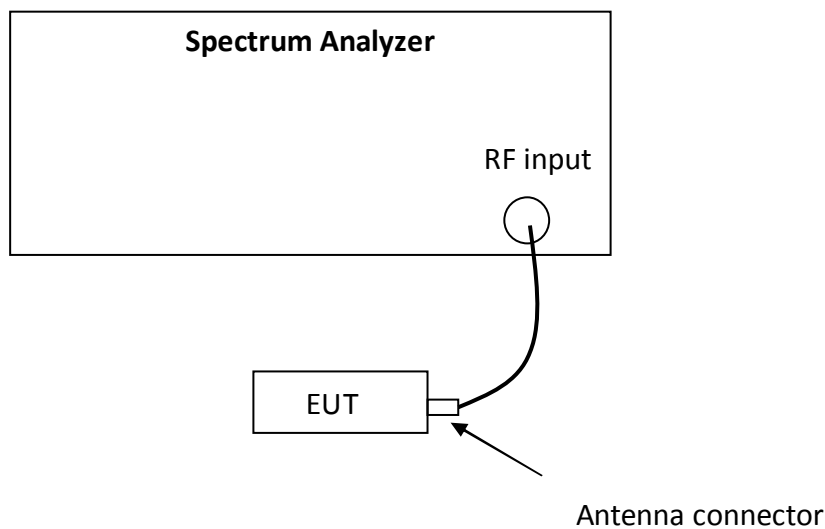

### 5.3 Test procedure and test setup

The power output per FCC §15.247(e) was tested according to DTS test procedure of “KDB558074 D01 DTS Meas Guidance” (clause 10.5 Method AVGPS-2 (trace averaging across on- and off-times of the EUT transmissions, followed by duty cycle correction)) for compliance to FCC 47CFR 15.247 requirements.

- a) Measure the duty cycle (x) of the transmitter output signal as described in Section 6.0.
- b) Set instrument center frequency to DTS channel center frequency.
- c) Set span to at least  $1.5 * \text{OBW}$ .
- d) Set RBW to:  $3 \text{ kHz} \leq \text{RBW} \leq 100 \text{ kHz}$ .
- e) Set VBW  $\geq 3 * \text{RBW}$ .
- f) Detector = power averaging (RMS) or sample detector (when RMS not available).
- g) Ensure that the number of measurement points in the sweep  $\geq 2 * \text{span}/\text{RBW}$ .
- h) Sweep time = auto couple.
- i) Do not use sweep triggering. Allow sweep to “free run”.
- j) Employ trace averaging (RMS) mode over a minimum of 100 traces.
- k) Use the peak marker function to determine the maximum amplitude level.
- l) Add  $10 \log (1/x)$ , where x is the duty cycle measured in step (a), to the measured PSD to compute the average PSD during the actual transmission time.
- m) If resultant value exceeds the limit, then reduce RBW (no less than 3 kHz) and repeat (note that this may require zooming in on the emission of interest and reducing the span in order to meet the minimum measurement point requirement as the RBW is reduced).

### 5.4 Test Protocol

Temperature: 25 °C  
Relative Humidity: 55 %

WLAN AVGSA Power Spectral Density						
Mode	Test Frequency(MHz)	Ant	Duty Cycle Factor (dB)	PSD (dBm/3kHz)	Limit (dBm/3kHz)	Result
802.11b	2412	Ant1	0.00	<b>-18.725</b>	8	Pass
802.11b	2437	Ant1	0.00	-19.010	8	Pass
802.11b	2462	Ant1	0.00	-19.828	8	Pass
802.11g	2412	Ant1	0.26	-22.391	8	Pass
802.11g	2437	Ant1	0.24	-22.509	8	Pass
802.11g	2462	Ant1	0.24	-23.348	8	Pass
802.11n(HT20)	2412	Ant1	0.38	-22.210	8	Pass
802.11n(HT20)	2437	Ant1	0.37	-22.148	8	Pass
802.11n(HT20)	2462	Ant1	0.29	-22.741	8	Pass
802.11n(HT40)	2422	Ant1	0.72	-25.249	8	Pass
802.11n(HT40)	2437	Ant1	0.47	-25.345	8	Pass
802.11n(HT40)	2452	Ant1	0.54	-25.480	8	Pass

**NOTE:**

$PSD(dBm/3KHz) = Corrected\ Reading(dBm/3KHz) + Factor(dB);$

$Factor(dB) = 10 * 10g(1/duty\ cycle\ (%)/100).$

Test Plots:

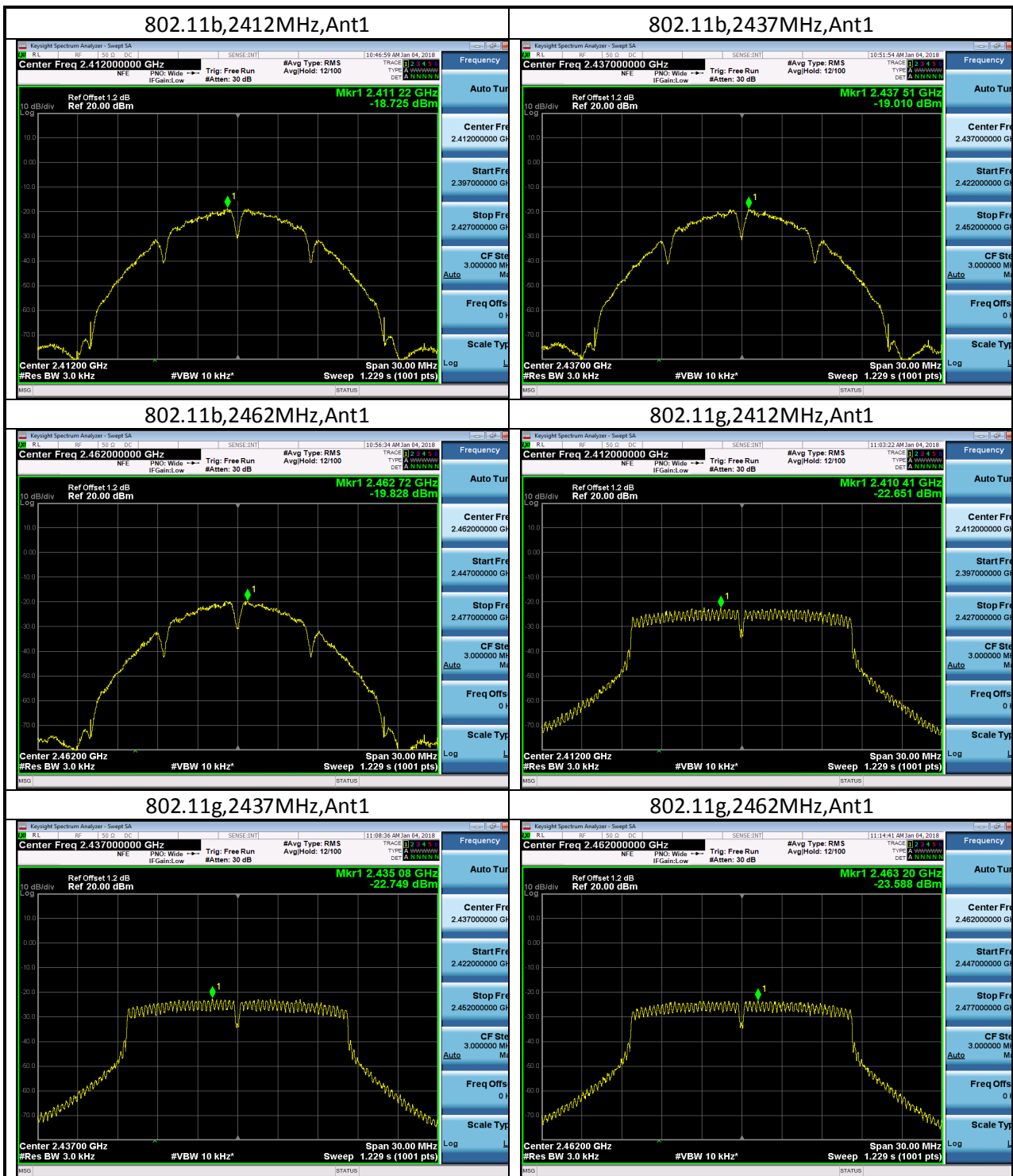

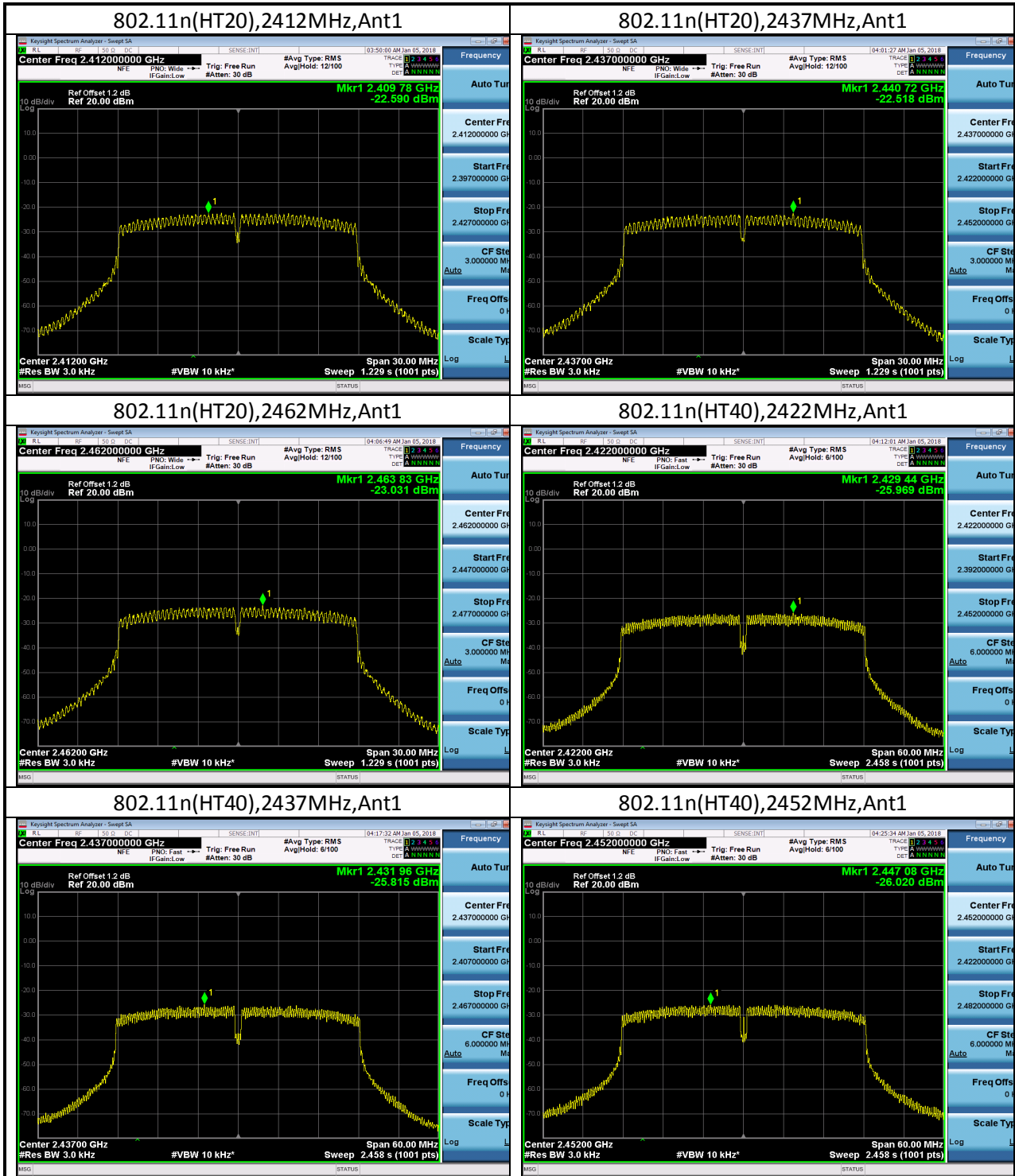



## 6 Emission outside the frequency band

Test result: Pass

### 6.1 Test limit

In any 100kHz bandwidth outside the frequency band in which the spread spectrum intentional radiator is operating, the radio frequency power that is produced by the intentional radiator shall be at least 30dB below that in the 100kHz bandwidth within the band that contains the highest level of the desired power.

### 6.2 Test Configuration

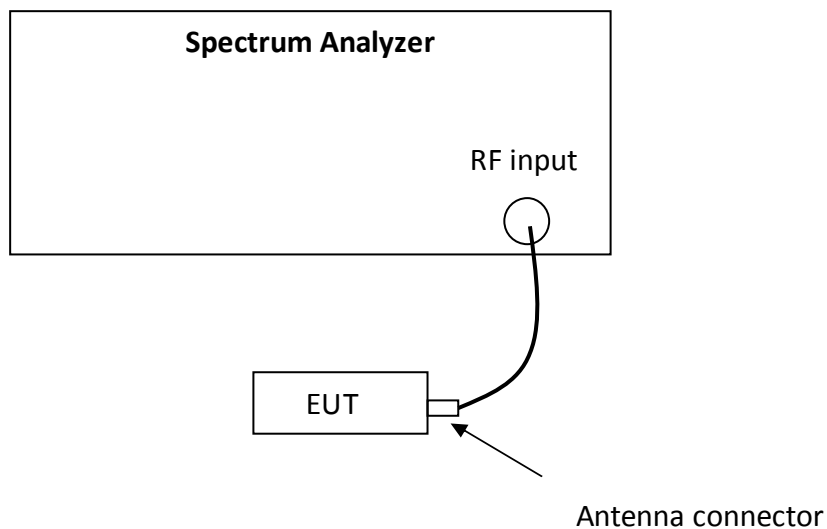

### 6.3 Test procedure and test setup

The EUT was tested according to DTS test procedure of “KDB558074 D01 DTS Meas Guidance” (clause 11.0) for compliance to FCC 47CFR 15.247 requirements.

#### Reference level measurement

Establish a reference level by using the following procedure:

- a) Set instrument center frequency to DTS channel center frequency.
- b) Set the span to  $\geq 1.5$  times the *DTS bandwidth*.
- c) Set the RBW = 100 kHz.
- d) Set the VBW  $\geq 3 \times$  RBW.
- e) Detector = peak.
- f) Sweep time = auto couple.
- g) Trace mode = max hold.
- h) Allow trace to fully stabilize.
- i) Use the peak marker function to determine the maximum PSD level.

Note that the channel found to contain the maximum PSD level can be used to establish the reference level.

#### Emission level measurement

- a) Set the center frequency and span to encompass frequency range to be measured.
- b) Set the RBW = 100 kHz.
- c) Set the VBW  $\geq 3 \times$  RBW.
- d) Detector = peak.
- e) Sweep time = auto couple.
- f) Trace mode = max hold.
- g) Allow trace to fully stabilize.
- h) Use the peak marker function to determine the maximum amplitude level.

Ensure that the amplitude of all unwanted emissions outside of the authorized frequency band (excluding restricted frequency bands) are attenuated by at least the minimum requirements specified in 11.1 a) or 11.1 b). Report the three highest emissions relative to the limit.

## 6.4 Test Protocol

Temperature: 25 °C

Relative Humidity: 55 %

Mode	Test Frequency(MHz)	Ant	Test No.	Frequency Range	Result
802.11b	2412	Ant1	1	Reference Level	Pass
802.11b	2412	Ant1	2	Band Edge	Pass
802.11b	2412	Ant1	3	1MHz~2400MHz	Pass
802.11b	2412	Ant1	4	2483.5MHz~5000MHz	Pass
802.11b	2412	Ant1	5	5000MHz~25000MHz	Pass
802.11b	2437	Ant1	1	Reference Level	Pass
802.11b	2437	Ant1	2	Band Edge	Pass
802.11b	2437	Ant1	3	1MHz~2400MHz	Pass
802.11b	2437	Ant1	4	2483.5MHz~5000MHz	Pass
802.11b	2437	Ant1	5	5000MHz~25000MHz	Pass
802.11b	2462	Ant1	1	Reference Level	Pass
802.11b	2462	Ant1	2	Band Edge	Pass
802.11b	2462	Ant1	3	1MHz~2400MHz	Pass
802.11b	2462	Ant1	4	2483.5MHz~5000MHz	Pass
802.11b	2462	Ant1	5	5000MHz~25000MHz	Pass
802.11g	2412	Ant1	1	Reference Level	Pass
802.11g	2412	Ant1	2	Band Edge	Pass
802.11g	2412	Ant1	3	1MHz~2400MHz	Pass
802.11g	2412	Ant1	4	2483.5MHz~5000MHz	Pass
802.11g	2412	Ant1	5	5000MHz~25000MHz	Pass
802.11g	2437	Ant1	1	Reference Level	Pass
802.11g	2437	Ant1	2	Band Edge	Pass
802.11g	2437	Ant1	3	1MHz~2400MHz	Pass
802.11g	2437	Ant1	4	2483.5MHz~5000MHz	Pass
802.11g	2437	Ant1	5	5000MHz~25000MHz	Pass
802.11g	2462	Ant1	1	Reference Level	Pass
802.11g	2462	Ant1	2	Band Edge	Pass
802.11g	2462	Ant1	3	1MHz~2400MHz	Pass

802.11g	2462	Ant1	4	2483.5MHz~5000MHz	Pass
802.11g	2462	Ant1	5	5000MHz~25000MHz	Pass
802.11n(HT20)	2412	Ant1	1	Reference Level	Pass
802.11n(HT20)	2412	Ant1	2	Band Edge	Pass
802.11n(HT20)	2412	Ant1	3	1MHz~2400MHz	Pass
802.11n(HT20)	2412	Ant1	4	2483.5MHz~5000MHz	Pass
802.11n(HT20)	2412	Ant1	5	5000MHz~25000MHz	Pass
802.11n(HT20)	2437	Ant1	1	Reference Level	Pass
802.11n(HT20)	2437	Ant1	2	Band Edge	Pass
802.11n(HT20)	2437	Ant1	3	1MHz~2400MHz	Pass
802.11n(HT20)	2437	Ant1	4	2483.5MHz~5000MHz	Pass
802.11n(HT20)	2437	Ant1	5	5000MHz~25000MHz	Pass
802.11n(HT20)	2462	Ant1	1	Reference Level	Pass
802.11n(HT20)	2462	Ant1	2	Band Edge	Pass
802.11n(HT20)	2462	Ant1	3	1MHz~2400MHz	Pass
802.11n(HT20)	2462	Ant1	4	2483.5MHz~5000MHz	Pass
802.11n(HT20)	2462	Ant1	5	5000MHz~25000MHz	Pass
802.11n(HT40)	2422	Ant1	1	Reference Level	Pass
802.11n(HT40)	2422	Ant1	2	Band Edge	Pass
802.11n(HT40)	2422	Ant1	3	1MHz~2400MHz	Pass
802.11n(HT40)	2422	Ant1	4	2483.5MHz~5000MHz	Pass
802.11n(HT40)	2422	Ant1	5	5000MHz~25000MHz	Pass
802.11n(HT40)	2437	Ant1	1	Reference Level	Pass
802.11n(HT40)	2437	Ant1	2	Band Edge	Pass
802.11n(HT40)	2437	Ant1	3	1MHz~2400MHz	Pass
802.11n(HT40)	2437	Ant1	4	2483.5MHz~5000MHz	Pass
802.11n(HT40)	2437	Ant1	5	5000MHz~25000MHz	Pass
802.11n(HT40)	2452	Ant1	1	Reference Level	Pass
802.11n(HT40)	2452	Ant1	2	Band Edge	Pass
802.11n(HT40)	2452	Ant1	3	1MHz~2400MHz	Pass
802.11n(HT40)	2452	Ant1	4	2483.5MHz~5000MHz	Pass
802.11n(HT40)	2452	Ant1	5	5000MHz~25000MHz	Pass

Test Plots:

