



FCC TEST REPORT

According to

CFR47 §15.247

Applicant	: Snapchat, Inc.
Address	: 63 Market Streets, Venice, CA 90291, USA
Manufacturer	: Weifang GoerTek Electronics Co.,Ltd
Address	: Gaoxin 2 Road,Free Trade Zone,Weifang,Shandong,261205,P.R.China
Equipment	: Spectacles
Model No.	: 001
Brand	: Snapchat
FCC ID	: 2AIRN-001

- The test result refers exclusively to the test presented test model / sample.
- Without written approval of **CerpPASS Technology (Suzhou) Co., Ltd.** the test report shall not be reproduced exc- ept in full.

I HEREBY CERTIFY THAT :

The measurements shown in this test report were made in accordance with the procedures given in **ANSI C63.10 – 2013** and the energy emitted by this equipment was **passed**.

CISPR PUB. 22 and FCC Part 15 in both radiated and conducted emission class B limits. Testing was carried out on Aug.20th,2016~Aug.31th, 2016 at **CerpPASS Technology (Suzhou) Co., Ltd.**

Laboratory Accreditation:

Approved by:

Miro Chueh
EMC/RF Manager

CerpPASS Technology Corporation Test Laboratory

<input type="checkbox"/>	NVLAP LAB Code:	200954-0
	TAF LAB Code:	1439

CerpPASS Technology (SuZhou) Co., Ltd.

<input checked="" type="checkbox"/>	NVLAP LAB Code:	200814-0
	CNAS LAB Code:	L5515



History of this Test Report

Attachment No.	Version	Date	Description
SEFC1608354	Rev 01	Sept.01, 2016	Initial release



Table of Contents

1. Report of Measurements and Examinations.....	5
1.1 List of Measurements and Examinations	5
2. Test Configuration of Equipment under Test.....	6
2.1 Feature of Equipment under Test	6
2.2 Carrier Frequency of Channels	7
2.3 Duty cycle	8
2.4 Test Manner.....	9
2.5 Description of Test System	10
2.6 Configuration of Tested System	10
2.7 General Information of Test	11
2.8 Measurement Uncertainty	11
3. Antenna Requirements	12
3.1 Standard Applicable.....	12
3.2 Antenna Construction and Directional Gain	12
4. Test of Conducted Emission	13
4.1 Test Limit	13
4.2 Test Procedures.....	13
4.3 Typical Test Setup	14
4.4 Measurement Equipment	14
4.5 Test Result and Data	15
5. Test of Radiated Emission	17
5.1 Test Limit	17
5.2 Test Procedures.....	17
5.3 Test Setting	18
5.4 Typical Test Setup	19
5.5 Measurement Equipment	21
5.6 Test Result and Data	22
6. Maximum Output Power	27
6.1 Test Limit	27
6.2 Test Procedure	27
6.3 Test Setup Layout.....	27
6.4 Measurement Equipment	27
6.5 Test Result and Data	28
7. Occupied Bandwidth	30
7.1 Test Limit	30
7.2 Test Procedures.....	30
7.3 Test Setup Layout.....	30
7.4 Measurement Equipment	30
7.5 Test Result and Data	31
8. Power Spectral Density.....	32
8.1 Test Limit	32
8.2 Test Procedure	32



8.3 Test Setup Layout..... 32

8.4 Measurement Equipment 32

8.5 Test Result and Data 33

9. Band Edges Measurement..... 34

9.1 Test Limit 34

9.2 in-band peak PSD level in 100 kHz (i.e., 20 dBc).Test Procedure 34

9.3 Test Setting 34

9.4 Test Setup Layout..... 35

9.5 Measurement Equipment 36

9.6 Test Result and Data 37

10. Restricted Bands of Operation..... 47

10.1 Labeling Requirement 47



1. Report of Measurements and Examinations

1.1 List of Measurements and Examinations

Performed Test Item	Normative References	Test Performed	Deviation	Result
Conducted Emission	FCC CFR Title 47 Part 15 Subpart C: 2014 Section 15.207	Yes	N/A	Pass
Radiated Emission	FCC CFR Title 47 Part 15 Subpart C: 2014 Section 15.209 RSS-Gen Issue 4 November 2014 Section 6.13	Yes	No	Pass
RF Antenna Conducted Spurious	FCC CFR Title 47 Part 15 Subpart C: 2014 Section 15.247(d) RSS-247 Issue 1 May 2015 Section 5.5	Yes	No	Pass
Radiated Emission Band Edge	FCC CFR Title 47 Part 15 Subpart C: 2014 15.247(d) RSS-247 Issue 1 May 2015 Section 5.5	Yes	No	Pass
Operation Frequency Range of 20dB Bandwidth	FCC CFR Title 47 Part 15 Subpart C: 2014 15.215(c)	Yes	No	Pass
Occupied Bandwidth	FCC CFR Title 47 Part 15 Subpart C: 2014 Section 15.247(a)(2) RSS-247 Issue 1 May 2015 Section 5.2(1)	Yes	No	Pass
Output Power	FCC CFR Title 47 Part 15 Subpart C: 2014 Section 15.247(b)(3) RSS-247 Issue 1 May 2015 Section 5.4(4)	Yes	No	Pass
Power Spectral Density	FCC CFR Title 47 Part 15 Subpart C: 2014 Section 15.247(e) RSS-247 Issue 1 May 2015 Section 5.2(2)	Yes	No	Pass



2. Test Configuration of Equipment under Test

2.1 Feature of Equipment under Test

Product name	Spectacles
Model No.	001
Power supply cable	Shielded, 1.0m

WIFI Module	nRF51822
BT Specification	V 4.0
Spreading	GFSK
Frequency Range	2402~2480MHz
Number of Channels	40
Data Rate	1Mbps(GFSK)
BT Channel Separation	2MHz
Antenna Type	See antenna requirement



2.2 Carrier Frequency of Channels

Bluetooth Working Frequency of Each Channel: (For V4.0)							
Channel	Frequency	Channel	Frequency	Channel	Frequency	Channel	Frequency
00	2402 MHz	01	2404 MHz	02	2406 MHz	03	2408 MHz
04	2410 MHz	05	2412 MHz	06	2414 MHz	07	2416 MHz
08	2418 MHz	09	2420 MHz	10	2422 MHz	11	2424 MHz
12	2426 MHz	13	2428 MHz	14	2430 MHz	15	2432 MHz
16	2434 MHz	17	2436 MHz	18	2438 MHz	19	2440 MHz
20	2442 MHz	21	2444 MHz	22	2446 MHz	23	2448 MHz
24	2450 MHz	25	2452 MHz	26	2454 MHz	27	2456 MHz
28	2458 MHz	29	2460 MHz	30	2462 MHz	31	2464 MHz
32	2466 MHz	33	2468 MHz	34	2470 MHz	35	2472 MHz
36	2474 MHz	37	2476 MHz	38	2478 MHz	39	2480 MHz



2.3 Duty cycle

Test Item	Duty cycle
-----------	------------

Mode	Frequency (MHz)	Measurement (%)
BLE	2440	66.7

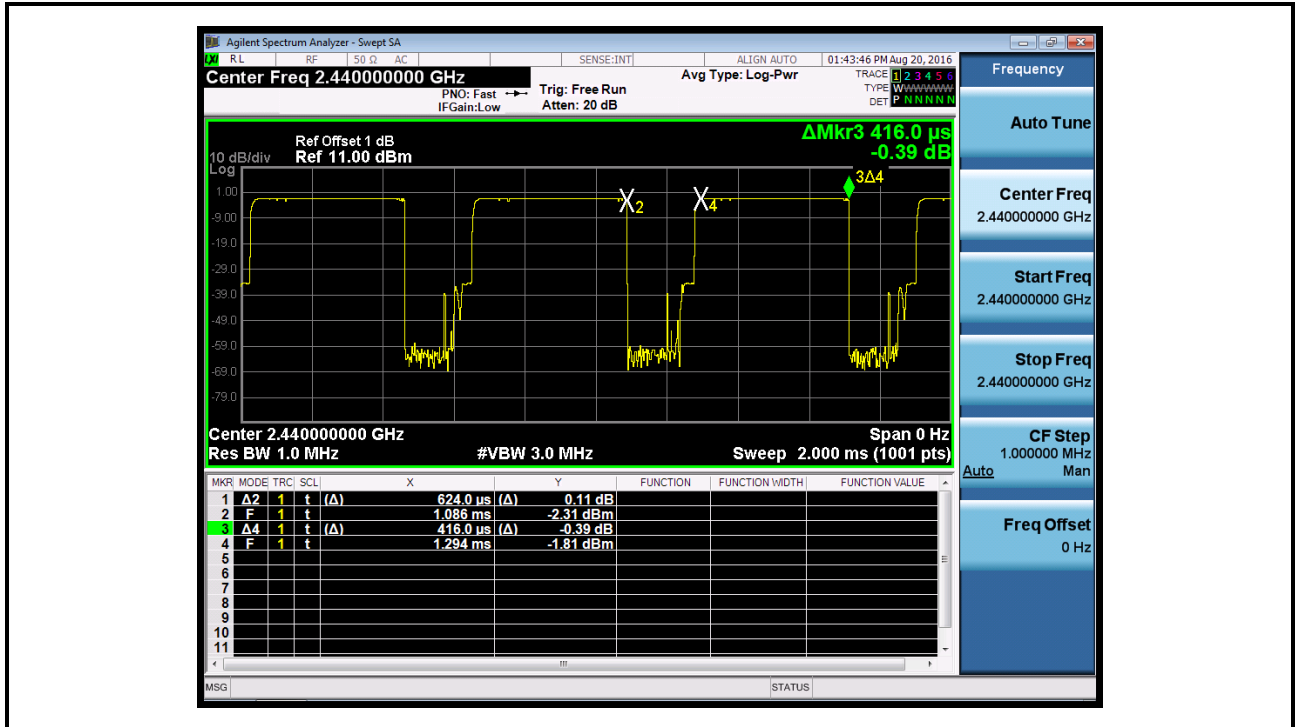



2.4 Test Manner

Test Manner	
1	During testing, the interface cables and equipment positions were varied according to C63.10.
2	Adjust the EUT at the test mode and the test channel. Then test.
Test mode	
1	Transmit by BLE



2.5 Description of Test System

No	Device	Manufacturer	Model No.	Description
1	Notebook PC	SONY	PCG-71811P	N/A

2.6 Configuration of Tested System

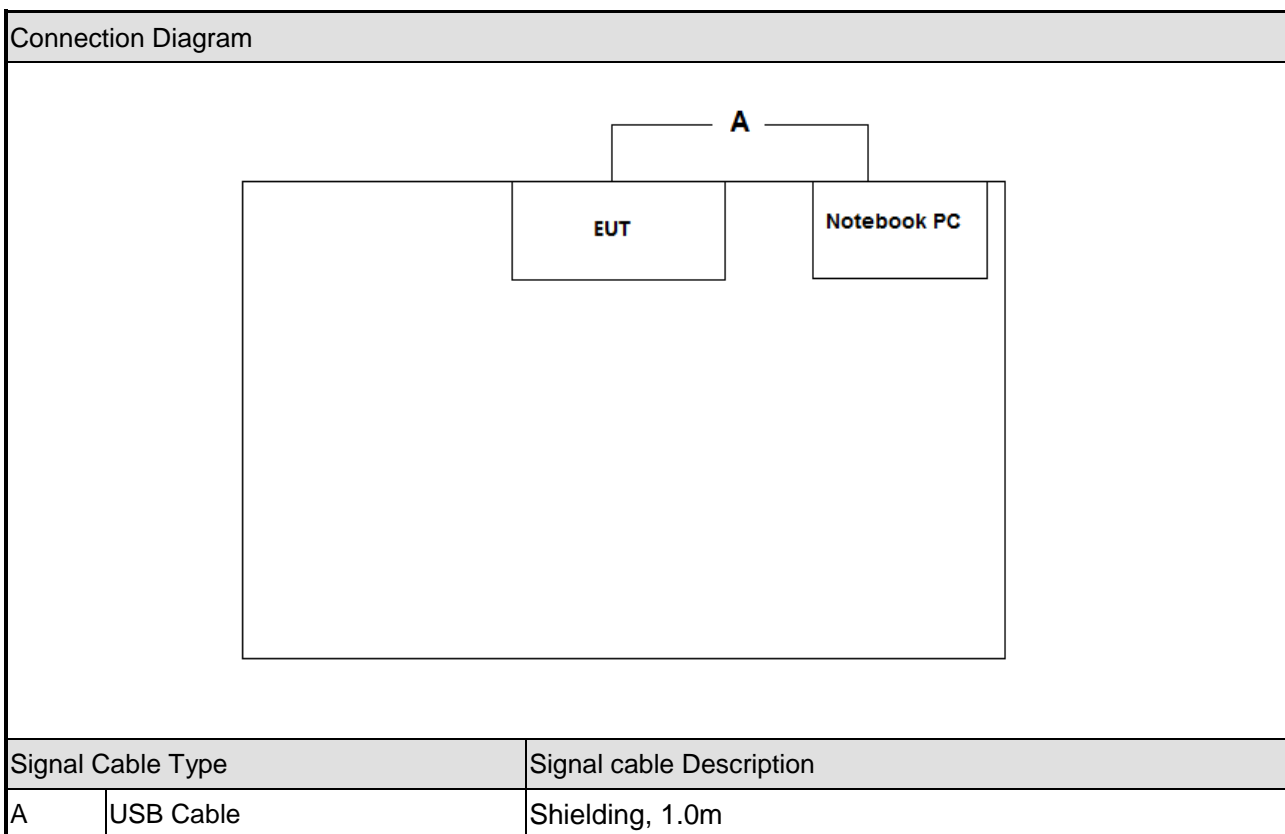

**2.7 General Information of Test**

Test Site:	CerpPASS Technology (Suzhou) Co., Ltd
Performand Location :	No.66,Tangzhuang Road, Suzhou Industrial Park, Jiangsu 215006, China
NVLAP LAB Code :	200814-0
FCC Registration Number :	916572, 331395
IC Registration Number :	7290A-1, 7290A-2

2.8 Measurement Uncertainty

Measurement Item	Measurement Frequency	Polarization	Uncertainty
Conducted Emission	9 kHz ~ 30 MHz	LINE/NEUTRAL	±2.71 dB
Radiated Emission	30 MHz ~ 25GHz	Vertical	±4.11 dB
		Horizontal	±4.10 dB
Occupied Bandwidth	---	---	±7500 Hz
Maximum Peak Output Power	---	---	±1.4 dB
Power Spectral Density	---	---	±2.2 dB



3. Antenna Requirements

3.1 Standard Applicable

For intentional device, according to FCC 47 CFR Section 15.203, an intentional radiator shall be designed to ensure that no antenna other than that furnished by the responsible party shall be used with the device.

And according to FCC 47 CFR Section 15.247 (b), if transmitting antennas of directional gain greater than 6dBi are used, the power shall be reduced by the amount in dB that the directional gain of the antenna exceeds 6dBi.

3.2 Antenna Construction and Directional Gain

Antenna	Manufacturer	Model No.	Peak Gain
Monopole Antenna	Weifang GoerTek Electronics Co.,Ltd	V03-1631	0.04dBi for2.4 GHz ~2.5 GHz



4. Test of Conducted Emission

4.1 Test Limit

Conducted Emissions were measured from 150 kHz to 30 MHz with a bandwidth of 9 KHz on the 120 VAC power and return leads of the EUT according to the methods defined in ANSI C63.10-2013. The EUT was placed on a nonmetallic stand in a shielded room 0.8 meters above the ground plane as shown in section 6.2.2. The interface cables and equipment positioning were varied within limits of reasonable applications to determine the position produced maximum conducted emissions.

Frequency (MHz)	Quasi Peak (dB μ V)	AVG (dB μ V)
0.15 – 0.5	66-56*	56-46*
0.5 – 5.0	56	46
5.0 – 30.0	60	50

*Decreases with the logarithm of the frequency.

4.2 Test Procedures

The EUT was setup according to ANSI C63.10, 2013. The EUT was placed on a platform of nominal size, 1 m by 1.5 m, raised 80 cm above the conducting ground plane. The vertical conducting plane was located 40 cm to the rear of the EUT. All other surfaces of EUT were at least 80 cm from any other grounded conducting surface. The EUT and simulators are connected to the main power through a line impedance stabilization network (LISN). The LISN provides a 50 ohm /50uH coupling impedance for the measuring equipment. The peripheral devices are also connected to the main power through a LISN. (Please refer to the block diagram of the test setup and photographs) Each current-carrying conductor of the EUT power cord, except the ground (safety) conductor, was individually connected through a LISN to the input power source. The excess length of the power cord between the EUT and the LISN receptacle were folded back and forth at the center of the lead to form a bundle not exceeding 40 cm in length. Conducted emissions were investigated over the frequency range from 0.15MHz to 30MHz using a receiver bandwidth of 9kHz.



4.3 Typical Test Setup

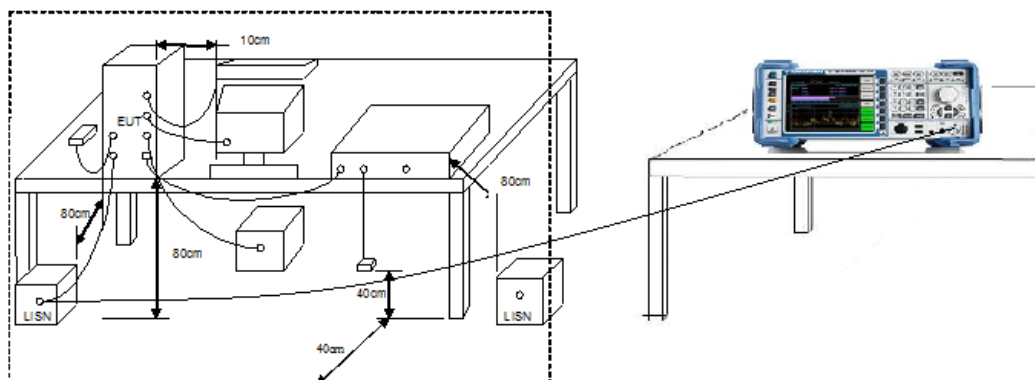

4.4 Measurement Equipment

Instrument	Manufacturer	Model No.	Serial No.	Calibration Date	Valid Date.
Test Receiver	R&S	ESCI	100565	2016.03.24	2017.03.23
AMN	R&S	ESH2-Z5	100182	2015.09.04	2016.09.03
Two-Line V-Network	R&S	ENV216	100325	2015.12.04	2016.12.03
ISN	FCC	FCC-TLISN-T2-02	20379	2016.03.24	2017.03.23
ISN	FCC	FCC-TLISN-T4-02	20380	2016.03.24	2017.03.23
ISN	FCC	FCC-TLISN-T8-02	20381	2016.03.24	2017.03.23
ISN	TESEQ	ISN ST08	30175	2016.03.24	2017.03.23
Current Probe	R&S	EZ-17	100303	2016.04.04	2017.04.03
Passive Voltage Probe	R&S	ESH2-Z3	100026	2016.03.29	2017.03.28
Pulse Limiter	R&S	ESH3-Z2	100529	2016.03.29	2017.03.28
Temperature/Humidity Meter	Zhicheng	ZC1-11	CEP-TH-004	2016.03.31	2017.03.30



4.5 Test Result and Data

Test Mode :	Mode 1: Normal Operation with BLE on		
AC Power :	AC 120V/60Hz	Phase :	LINE
Temperature :	22°C	Humidity :	50%
Pressure(mbar) :	1002	Date:	2016/08/31

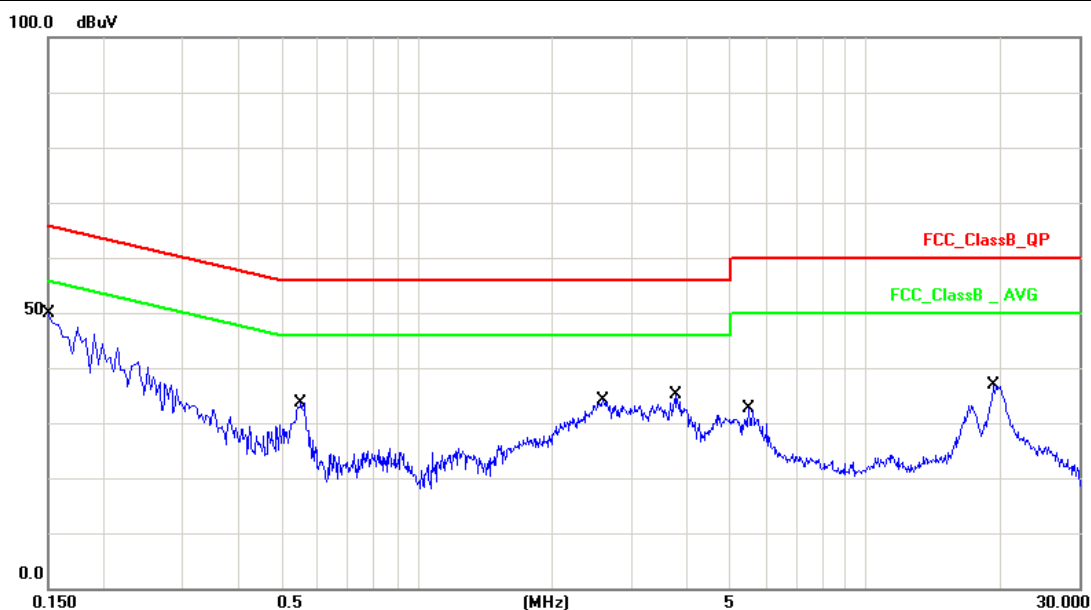

No.	Frequency (MHz)	Factor (dB)	Reading (dBuV)	Level (dBuV)	Limit (dBuV)	Margin (dB)	Detector
1	0.1500	10.13	35.71	45.84	65.99	-20.15	QP
2	0.1500	10.13	16.70	26.83	55.99	-29.16	AVG
3	0.5500	10.16	21.51	31.67	56.00	-24.33	QP
4	0.5500	10.16	15.21	25.37	46.00	-20.63	AVG
5	2.6020	10.18	20.43	30.61	56.00	-25.39	QP
6	2.6020	10.18	14.10	24.28	46.00	-21.72	AVG
7	3.7820	10.20	17.06	27.26	56.00	-28.74	QP
8	3.7820	10.20	9.93	20.13	46.00	-25.87	AVG
9	5.5020	10.25	15.24	25.49	60.00	-34.51	QP
10	5.5020	10.25	9.13	19.38	50.00	-30.62	AVG
11	19.3860	10.37	20.53	30.90	60.00	-29.10	QP
12	19.3860	10.37	13.71	24.08	50.00	-25.92	AVG

Note: Measurement Level = Reading Level + Correct Factor



Test Mode :	Mode 1: Normal Operation with BLE on		
AC Power :	AC 120V/60Hz	Phase :	NEUTRAL
Temperature :	22°C	Humidity :	50%
Pressure(mbar) :	1002	Date:	2016/08/31

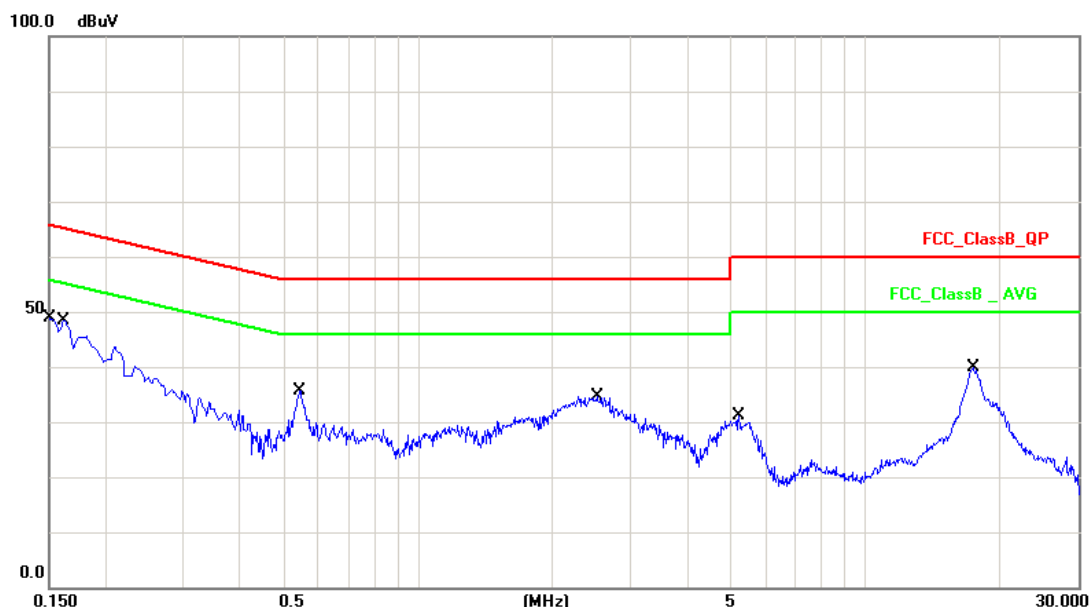

No.	Frequency (MHz)	Factor (dB)	Reading (dBuV)	Level (dBuV)	Limit (dBuV)	Margin (dB)	Detector
1	0.1500	10.13	35.26	45.39	65.99	-20.60	QP
2	0.1500	10.13	17.62	27.75	55.99	-28.24	AVG
3	0.1620	10.13	33.57	43.70	65.36	-21.66	QP
4	0.1620	10.13	16.87	27.00	55.36	-28.36	AVG
5	0.5460	10.15	23.13	33.28	56.00	-22.72	QP
6	0.5460	10.15	16.16	26.31	46.00	-19.69	AVG
7	2.5260	10.19	21.57	31.76	56.00	-24.24	QP
8	2.5260	10.19	15.89	26.08	46.00	-19.92	AVG
9	5.2340	10.26	14.94	25.20	60.00	-34.80	QP
10	5.2340	10.26	6.62	16.88	50.00	-33.12	AVG
11	17.5220	10.48	24.65	35.13	60.00	-24.87	QP
12	17.5220	10.48	19.07	29.55	50.00	-20.45	AVG

Note: Measurement Level = Reading Level + Correct Factor



5. Test of Radiated Emission

5.1 Test Limit

In any 100kHz bandwidth outside the frequency band in which the spread spectrum or digitally modulated intentional radiator is operating, the radio frequency power that is produced by the intentional radiator shall be at least 20dB below that in the 100kHz bandwidth within the band that contains the highest level of the desired power, based on either an RF conducted or a radiated measurement. If the transmitter measurement is based on the maximum conducted output power, the attenuation required under this paragraph shall be 30dB instead of 20dB. In addition, radiated emissions which fall in section 15.205(a) the restricted bands must also comply with the radiated emission limit specified in section 15.209(a).

FREQUENCIES(MHz)	FIELD STRENGTH (microvolts/meter)	MEASUREMENT DISTANCE(meters)
0.009~0.490	2400/F(kHz)	300
0.490~1.705	24000/F(kHz)	30
1.705~30.0	30	30
30~88	100	3
88~216	150	3
216~960	200	3
Above 960	500	3

5.2 Test Procedures

KDB 558074 D01v03r05 - Section 12.0 & Section 12.1



5.3 Test Setting

Quasi-Peak Measurements below 1GHz

1. Analyzer center frequency was set to the frequency of the radiated spurious emission of interest
2. Span was set greater than 1MHz
3. RBW = 120 kHz
4. Detector = CISPR quasi-peak
5. Sweep time = auto couple
6. Trace was allowed to stabilize

Peak Measurements above 1GHz

1. Analyzer center frequency was set to the frequency of the radiated spurious emission of interest
2. RBW = 1MHz
3. VBW = 3MHz
4. Detector = peak
5. Sweep time = auto couple
6. Trace mode = max hold
7. Trace was allowed to stabilize

Average Measurements above 1GHz

7.8.3. Average Field Strength Measurements

1. Analyzer center frequency was set to the frequency of the radiated spurious emission of interest
2. RBW = 1MHz
3. VBW $\geq 1/T$
4. De As an alternative, the instrument may be set to linear detector mode. Ensure that video filtering is applied in linear voltage domain (rather than in a log or dB domain). Some instruments require linear display mode in order to accomplish this. Others have a setting for Average-VBW Type, which can be set to "Voltage" regardless of the display mode
5. Detector = Peak
6. Sweep time = auto
7. Trace mode = max hold
8. Allow max hold to run for at least 50 times (1/duty cycle) traces



5.4 Typical Test Setup

9kHz~30MHz Test Setup

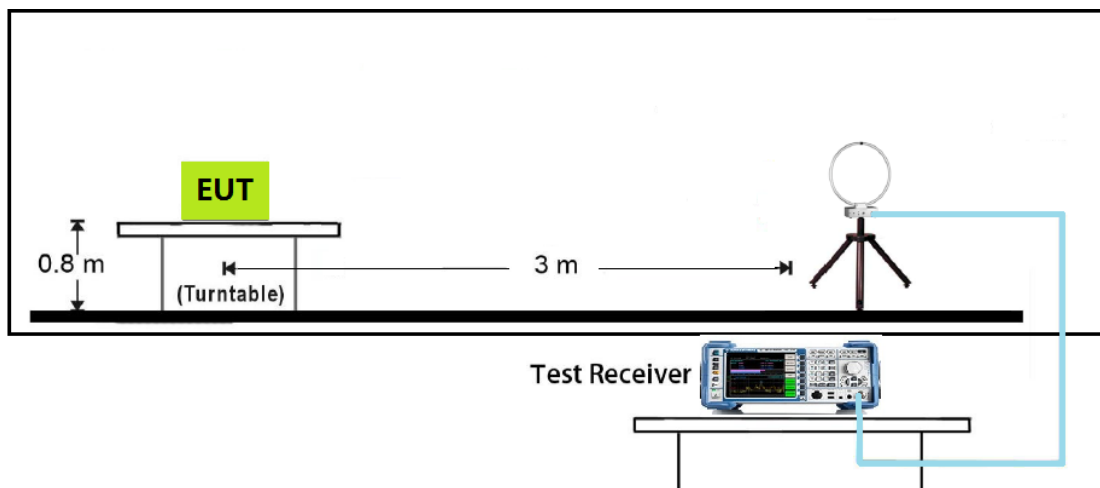

Below 1GHz Test Setup

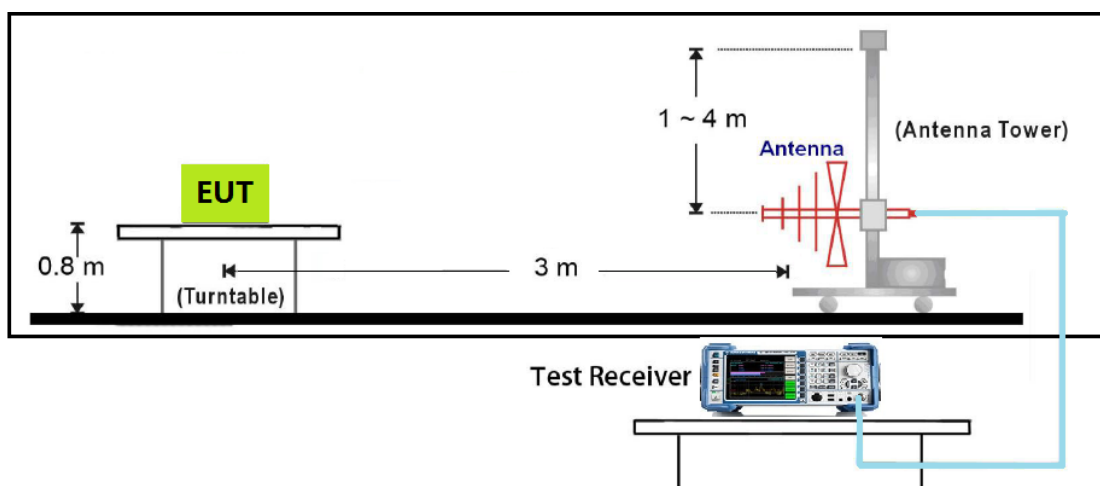



1GHz~18GHz Test Setup

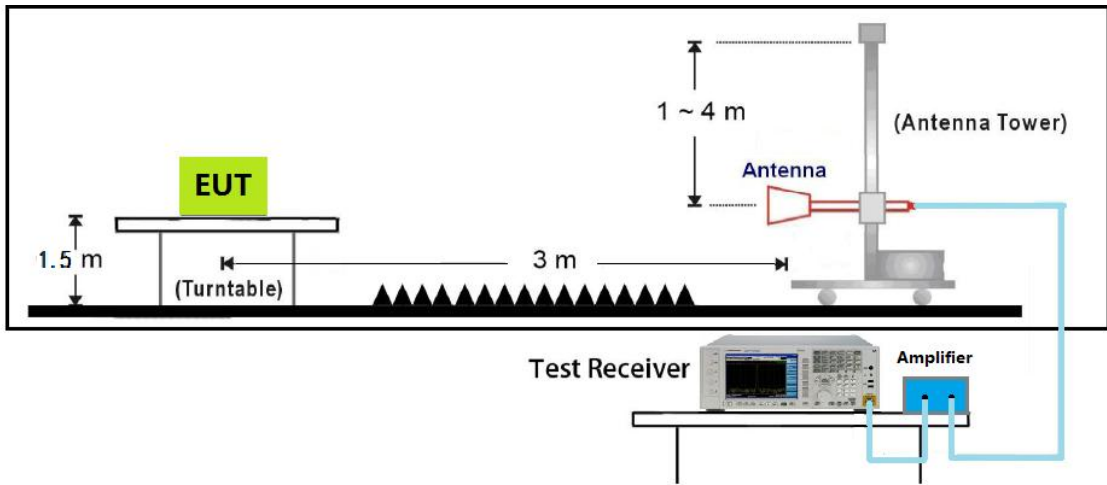

18GHz~40GHz Test Setup

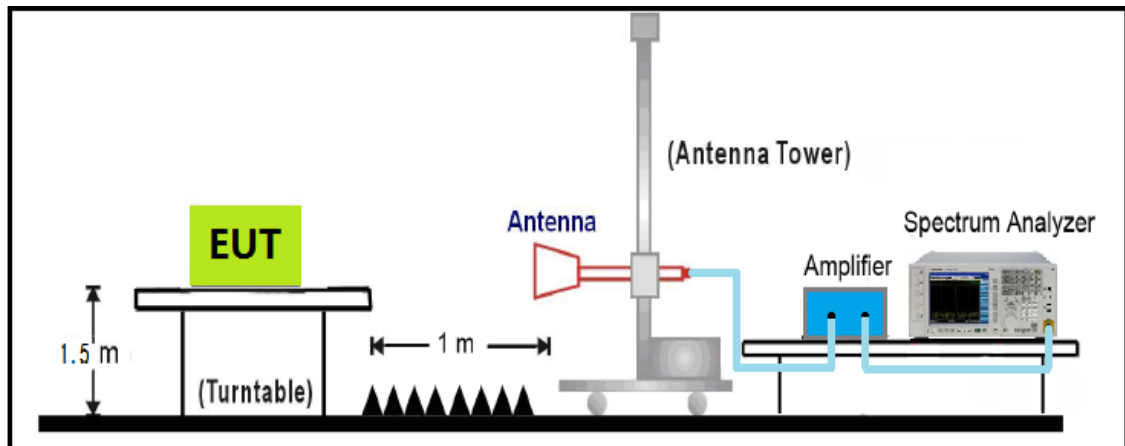



5.5 Measurement Equipment

Instrument/Ancillary	Manufacturer	Model No.	Serial No.	Calibration Date	Valid Date.
EMI Test Receiver	R&S	ESCI	101183	2016.03.28	2017.03.29
Spectrum Analyzer	N9010A	Agilent	MY53400169	2015.11.11	2016.11.11
Spectrum Analyzer	R&S	FSP40	100324	2016.03.23	2017.03.24
H64 Preamplifier	HP	8447F	3113A05582	2016.03.24	2017.03.23
Preamplifier	songyi	EM330	60618	2016.03.29	2017.03.28
Preamplifier	Agilent	8449B	3008A02342	2016.03.29	2017.03.28
Preamplifier	COM-POWER	PA-840	711885	2016.03.29	2017.03.28
Bilog Antenna	Sunol Science	JB1	A072414-1	2016.04.22	2017.04.21
Broad-Band Horn Antenna	Schwarzbeck	BBHA9120D	9120D-619	2016.04.20	2017.04.19
Broad-Band Horn Antenna	Schwarzbeck	BBHA9170	9170-347	2016.04.20	2017.04.19
Temperature/ Humidity Meter	Zhicheng	ZC1-11	CEP-TH-002	2016.03.31	2017.03.30
EZ-EMC	Fala	Ver CT3A1	N/A	N/A	N/A



5.6 Test Result and Data

The worst case of Radiated Emission below 1GHz:

Engineer :Ternence	Site : EMC Lab AC 102
Limit : FCC_CLASS_B_03M_QP	Margin : 6
EUT : 001	Probe : VERTICAL/ HORIZONTAL
Power : AC 120V/60Hz	Note : Normal Link

No.	Frequency (MHz)	Factor (dB/m)	Reading (dBuV)	Level (dBuV/m)	Limit (dBuV/m)	Margin (dB)	Det.	AntPol. H/V
1	30.9699	-2.85	29.24	26.39	40.00	-13.61	QP	H
2	322.9399	-6.29	37.29	31.00	46.00	-15.00	QP	H
3	432.5500	-4.61	43.44	38.83	46.00	-7.17	QP	H
4	720.6399	1.39	31.28	32.67	46.00	-13.33	QP	H
5	792.4198	0.74	35.17	35.91	46.00	-10.09	QP	H
6	828.3099	1.17	36.09	37.26	46.00	-8.74	QP	H

No.	Frequency (MHz)	Factor (dB/m)	Reading (dBuV)	Level (dBuV/m)	Limit (dBuV/m)	Margin (dB)	Det.	AntPol. H/V
1	143.4900	-7.77	32.72	24.95	43.50	-18.55	QP	V
2	352.0400	-6.74	33.84	27.10	46.00	-18.90	QP	V
3	432.5500	-4.61	43.91	39.30	46.00	-6.70	QP	V
4	630.4298	-1.66	31.04	29.38	46.00	-16.62	QP	V
5	720.6399	1.39	29.98	31.37	46.00	-14.63	QP	V
6	831.2199	1.24	33.21	34.45	46.00	-11.55	QP	V

Note:

- All Readings below 1GHz are Quasi-Peak, above are performed with peak and/or AVG measurements as necessary.
- Measurement Level = Reading Level + Correct Factor



Above 1G:

Engineer : Ternence	Site : EMC Lab AC 102
Limit : FCC_15_03M_PK	Margin : 6
EUT : 001	Probe : VERTICAL/ HORIZONTAL
Power : AC 120V/60Hz	Note : Transmit BLE at 2402MHz

No.	Frequency (MHz)	Factor (dB/m)	Reading (dBuV)	Level (dBuV/m)	Limit (dBuV/m)	Margin (dB)	Det.	AntPol. H/V
1	4804.00	-3.89	48.87	44.98	74.00	-29.02	peak	H
2	7206.00	0.54	47.09	47.63	74.00	-26.37	peak	H
3	4804.00	-3.89	47.42	43.53	74.00	-30.47	peak	V
4	7206.00	0.54	45.55	46.09	74.00	-27.91	peak	V

Engineer : Ternence	Site : EMC Lab AC 102
Limit : FCC_15_03M_PK	Margin : 6
EUT : 001	Probe : VERTICAL/ HORIZONTAL
Power : AC 120V/60Hz	Note : Transmit BLE at 2440MHz

No.	Frequency (MHz)	Factor (dB/m)	Reading (dBuV)	Level (dBuV/m)	Limit (dBuV/m)	Margin (dB)	Det.	AntPol. H/V
1	4880.00	-3.84	45.85	42.01	74.00	-31.99	peak	H
2	7320.00	0.81	43.95	44.76	74.00	-29.24	peak	H
3	4880.00	-3.84	46.07	42.23	74.00	-31.77	peak	V
4	7320.00	0.81	43.98	44.79	74.00	-29.21	peak	V



Engineer : Ternence	Site : EMC Lab AC 102
Limit : FCC_15_03M_PK	Margin : 6
EUT : 001	Probe : VERTICAL/ HORIZONTAL
Power : AC 120V/60Hz	Note : Transmit BLE at 2480MHz

No.	Frequency (MHz)	Factor (dB/m)	Reading (dBuV)	Level (dBuV/m)	Limit (dBuV/m)	Margin (dB)	Det.	AntPol. H/V
1	4960.00	-3.79	45.95	42.16	74.00	-31.84	peak	H
2	7440.00	1.10	43.58	44.68	74.00	-29.32	peak	H
3	4960.00	-3.79	45.57	41.78	74.00	-32.22	peak	V
4	7440.00	1.10	43.50	44.60	74.00	-29.40	peak	V



The worst case of Radiated Emission 1~18GHz:

Site: AC102	Time: 2016/08/21
Limit: FCC_Part15.209_RE(3m)	Margin: 0
Probe: N/A	Polarity: Horizontal
EUT: 001	Power: AC 120V/60Hz
Note: Mode:Transmit BLE at 2402MHz	

100.0 dBuV/m

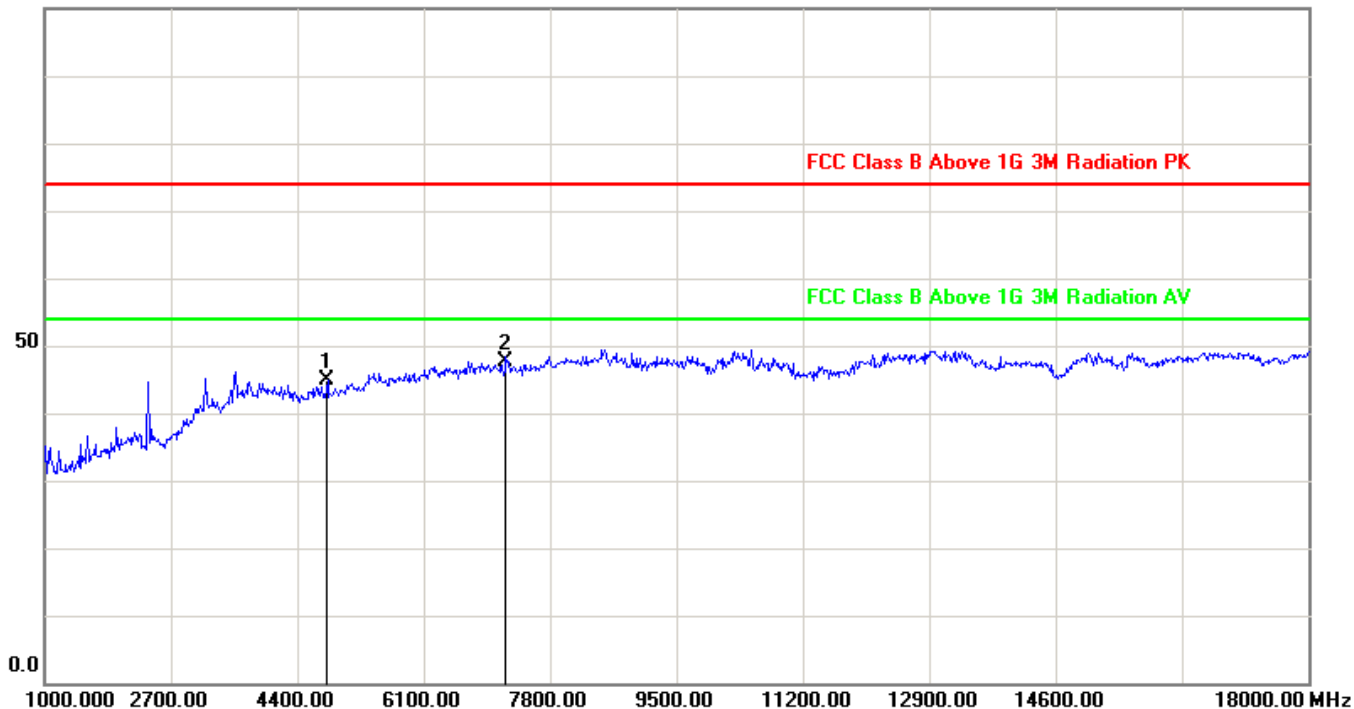

No.	Frequency (MHz)	Factor (dB/m)	Reading (dBuV)	Level (dBuV/m)	Limit (dBuV/m)	Margin (dB)	Det.
1	4804.000	-3.89	48.87	44.98	74.00	-29.02	peak
2	7206.000	0.54	47.09	47.63	74.00	-26.37	peak



Site: AC102	Time: 2016/08/21
Limit: FCC_Part15.209_RE(3m)	Margin: 0
Probe: N/A	Polarity: Vertical
EUT: 001	Power: AC 120V/60Hz
Note: Mode:Transmit BLE at 2402MHz	

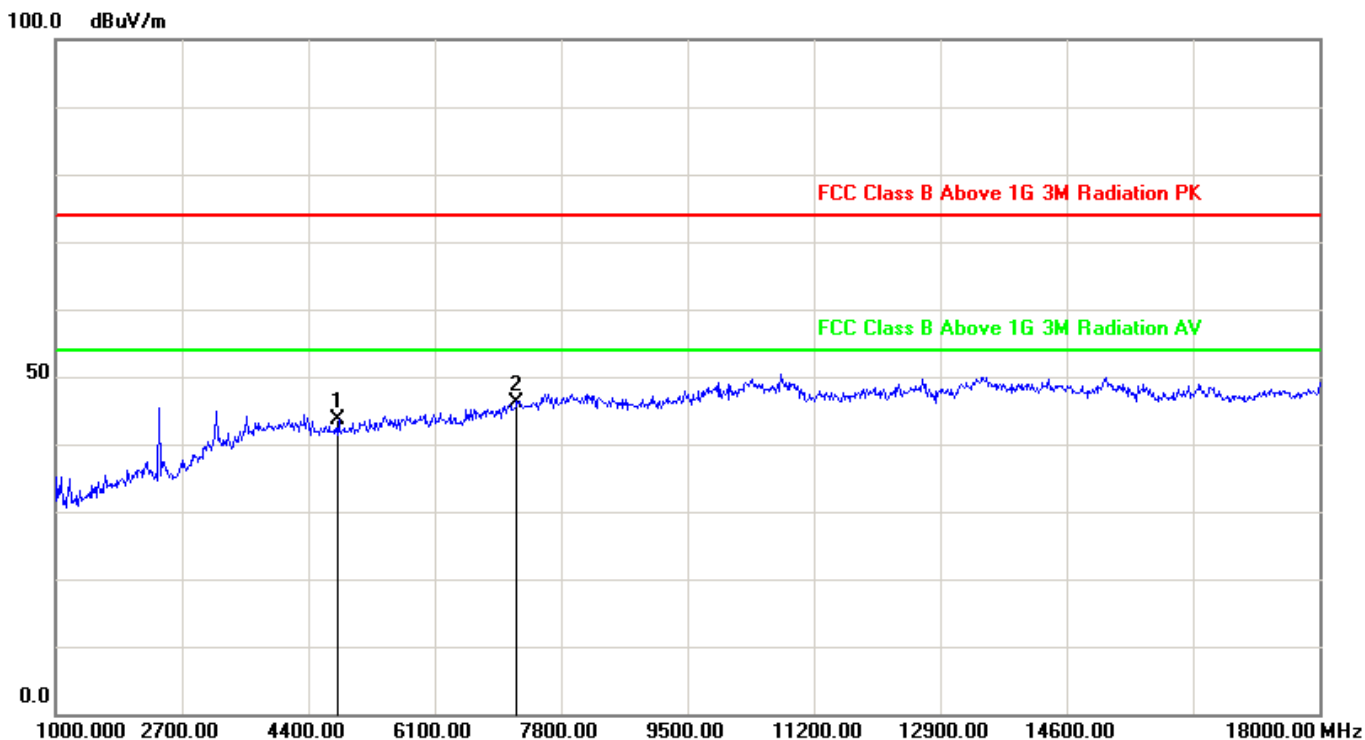

No.	Frequency (MHz)	Factor (dB/m)	Reading (dBuV)	Level (dBuV/m)	Limit (dBuV/m)	Margin (dB)	Det.
1	4804.000	-3.89	47.42	43.53	74.00	-30.47	peak
2	7206.000	0.54	45.55	46.09	74.00	-27.91	peak

Note:

1. All Readings below 1GHz are Quasi-Peak, above are performed with peak and/or AVG measurements as necessary.
2. Measurement Level = Reading Level + Correct Factor
3. The test trace is same as the ambient noise (the test frequency range: 9kHz~30MHz, 18GHz~40GHz), therefore no data appear in the report.



6. Maximum Output Power

6.1 Test Limit

The maximum power shall be less 1Watt (30dBm).

The conducted output power limits specified in §15.247(b) are based on the use of transmit antennae with directional gains that do not exceed 6 dBi. If transmit antennae with an effective directional gain greater than 6 dBi are used, then the conducted output power from the EUT shall be reduced as specified in §15.247(b) and (c).

Per RSS247 Issue 1 Section 5.4(4), for DTSs employing digital modulation techniques operating in the bands 902-928 MHz and 2400-2483.5 MHz, the maximum conducted output power shall not exceed 1W.

6.2 Test Procedure

The EUT was tested according to DTS test procedure of KDB 558074 for compliance to FCC 47CFR 15.247 requirements. The maximum conducted AVG output power using KDB 558074 D01v03r05 - Section 9.2.3.2 AVGPm-G Average Power Method.

The Maximum peak conducted output power using KDB 558074 D01v03r05 - Section 9.1.1 RBW ≥ DTS bandwidth Method.

6.3 Test Setup Layout

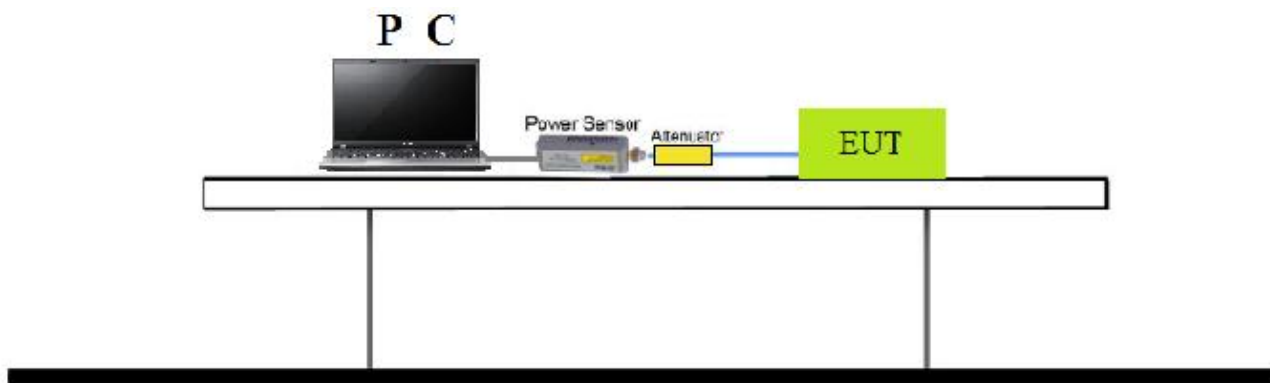

6.4 Measurement Equipment

Instrument	Manufacturer	Type No.	Serial No.	Calibration Date	Valid Date.
PC	Lenovo	E40-70	MP078UQV	N/A	N/A
POWER SENSOR	Agilent	U2021XA	MY53260020	2016/03/27	2017/03/26
Series Power Meter	ANRITSU	ML2495A	1224005	2016/03/27	2017/03/26
Temperature/Humidity Meter	Zhicheng	ZC1-11	CEP-TH-003	2016/03/31	2017/03/30



6.5 Test Result and Data

Power output test was verified over all data rates of each mode shown as below, and then choose the maximum power output (blue marker) for final test of each channel.

MCS Index for 802.11n	Spatial Streams	Data Rate(Mbps)					
		802.11b	802.11g	20MHz Bandwidth		40MHz Bandwidth	
				800ns GI	400ns GI	800ns GI	400ns GI
0	1	1	6	6.5	7.2	13.5	15.0
1	1	2	9	13.0	14.4	27.0	30.0
2	1	5.5	12	19.5	21.7	40.5	45.0
3	1	11	18	26.0	28.9	54.0	60.0
4	1	--	24	39.0	43.3	81.0	90.0
5	1	--	36	52.0	57.8	108.0	120.0
6	1	--	48	58.5	65.0	121.5	135.0
7	1	--	54	65.0	72.2	135.0	150.0
8	2	--	--	13.0	14.4	27.0	30.0
9	2	--	--	26.0	28.9	54.0	60.0
10	2	--	--	39.0	43.3	81.0	90.0
11	2	--	--	52.0	57.8	108.0	120.0
12	2	--	--	78.0	86.7	162.0	180.0
13	2	--	--	104.0	115.6	216.0	240.0
14	2	--	--	117.0	130.0	243.0	270.0
15	2	--	--	130.0	144.0	270.0	300.0



Test Item	Maximum Output Power
Test Mode	Transmit by BLE
Test Date	2016-08-20

Channel No.	Frequency (MHz)	Peak Power (dBm)	Required Limit (dBm)	Result
00	2402	-1.75	30	Pass
19	2440	-1.05	30	Pass
39	2480	-0.75	30	Pass



7. Occupied Bandwidth

7.1 Test Limit

Systems using digital modulation techniques may operate in the 902 - 928 MHz, 2400 - 2483.5 MHz, and 5725- 5850 MHz band. The minimum 6 dB bandwidth shall be at least 500 kHz.

7.2 Test Procedures

According to KDB 558074 D01v03r05 - Section 8.1.

- a. The transmitter output was connected to the spectrum analyzer.
- b. Set RBW of spectrum analyzer to 100KHz and VBW \geq 3x RBW.
- c. The 6 dB bandwidth is defined as the total spectrum the power of which is higher than peak power minus 6 dB.
- d. The 6dB Bandwidth was measured and recorded.

7.3 Test Setup Layout

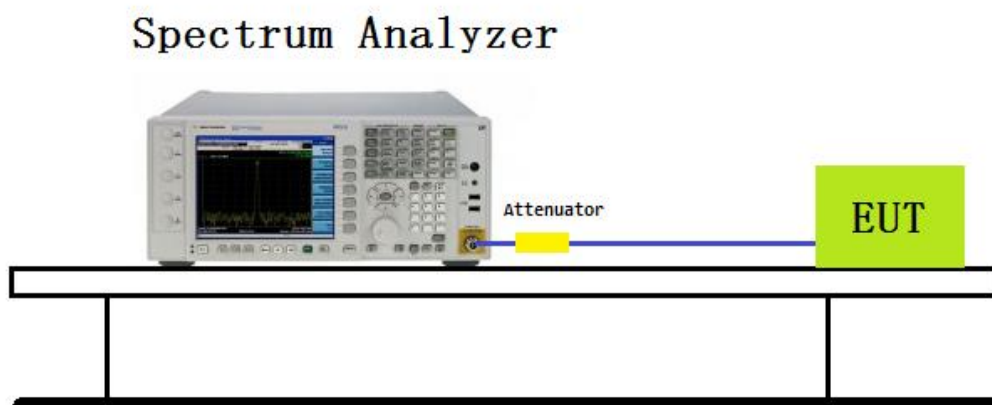

7.4 Measurement Equipment

Instrument/Ancillary	Model No.	Manufacturer	Serial No.	Calibration Date	Valid Date
Spectrum Analyzer	N9010A	Agilent	MY53400169	2015.11.11	2016.11.11



7.5 Test Result and Data

Test Item	Occupied Bandwidth
Test Mode	Transmit by BLE
Test Date	2016-08-20

Channel No.	Frequency (MHz)	-6dB Measurement Level (kHz)	99% Occupied Bandwidth (MHz)	Result
00	2402	711.2	1.1131	Pass
19	2440	710.8	1.1101	Pass
39	2480	703.0	1.1131	Pass

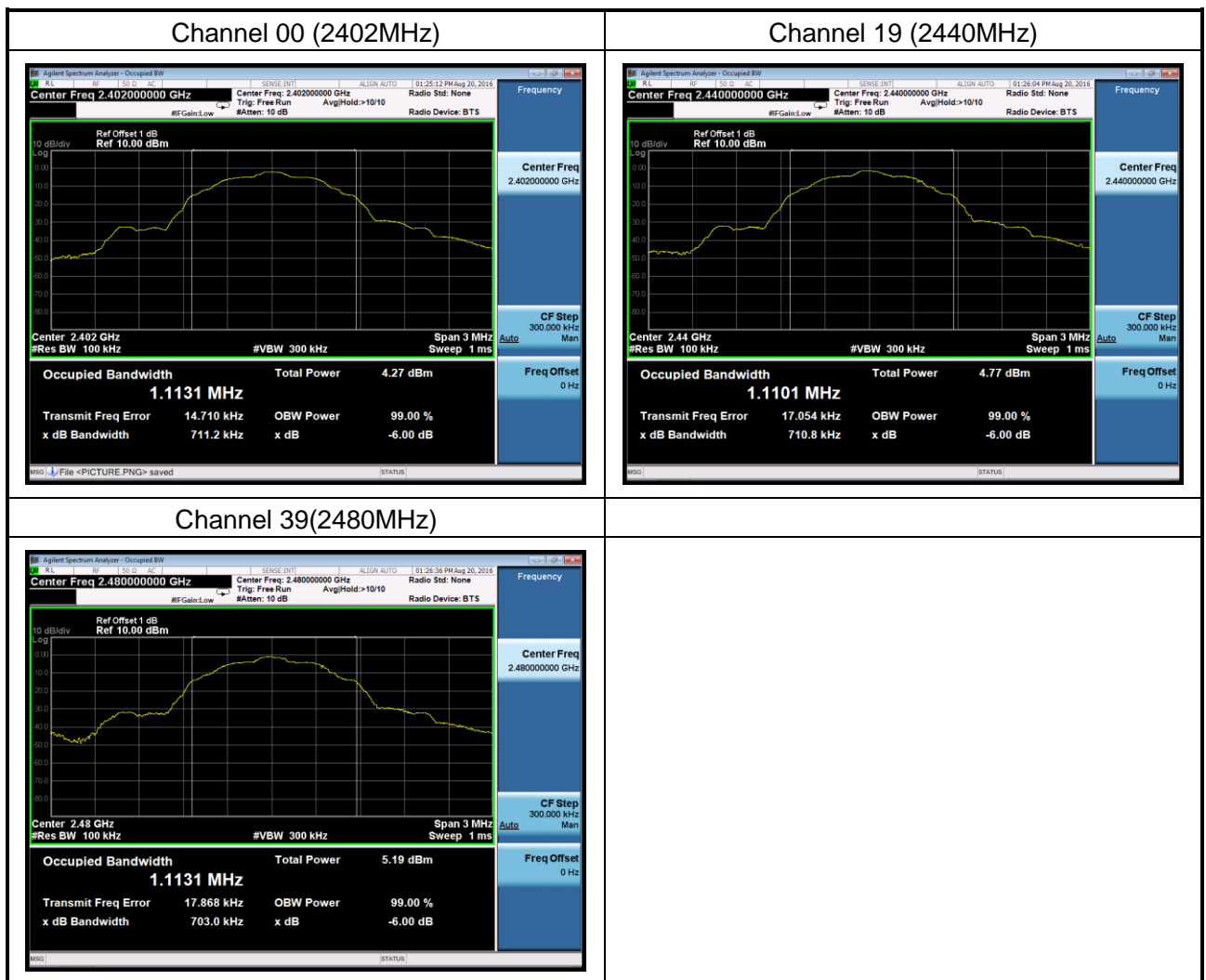



8. Power Spectral Density

8.1 Test Limit

The Maximum of Power Spectral Density Measurement is 8dBm.

8.2 Test Procedure

The EUT was setup according to ANSI C63.10, 2013; tested according to DTS test procedure of KDB 558074 for compliance to FCC 47CFR 15.247 requirements.

The maximum power spectral density using KDB 558074 section 10.2 PKPSD (peak PSD) method.

- a) Set analyzer center frequency to DTS channel center frequency.
- b) Set the span to 1.5 times the DTS bandwidth.
- c) Set the RBW to: $3 \text{ kHz} \leq \text{RBW} \leq 100 \text{ kHz}$. (Actually we use 3kHz RBW)
- d) Set the VBW $\geq 3 \times \text{RBW}$.
- e) Detector = peak.
- f) Sweep time = auto couple.
- g) Trace mode = max hold.
- h) Allow trace to fully stabilize.
- i) Use the peak marker function to determine the maximum amplitude level within the band.
- j) If measured value exceeds limit, reduce RBW (no less than 3 kHz) and repeat.

8.3 Test Setup Layout

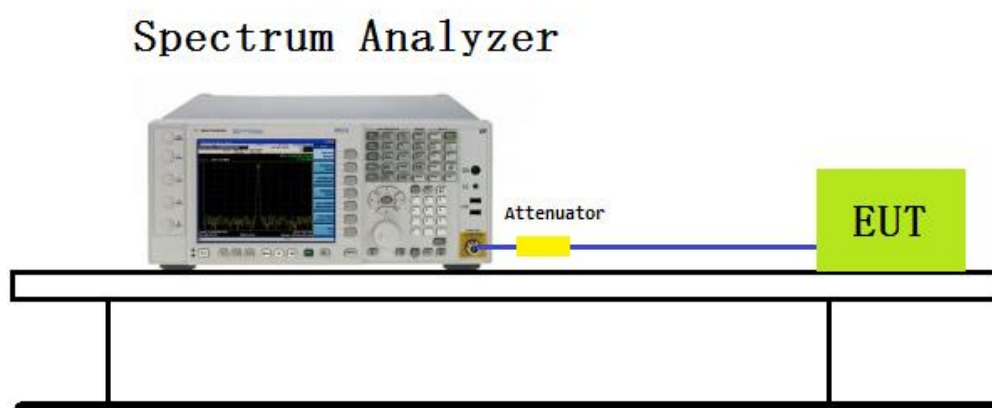

8.4 Measurement Equipment

Instrument/Ancillary	Model No.	Manufacturer	Serial No.	Calibration Date	Valid Date
Spectrum Analyzer	N9010A	Agilent	MY53400169	2015.11.11	2016.11.11



8.5 Test Result and Data

Test Item	Power Spectral Density
Test Mode	Transmit by BLE
Test Date	2016-08-20

Channel	Frequency (MHz)	Power Spectral Density (dBm/3kHz)	Limit (dBm/3kHz)	Result
00	2402	-3.158	8	Pass
19	2440	-2.700	8	Pass
39	2480	-2.399	8	Pass

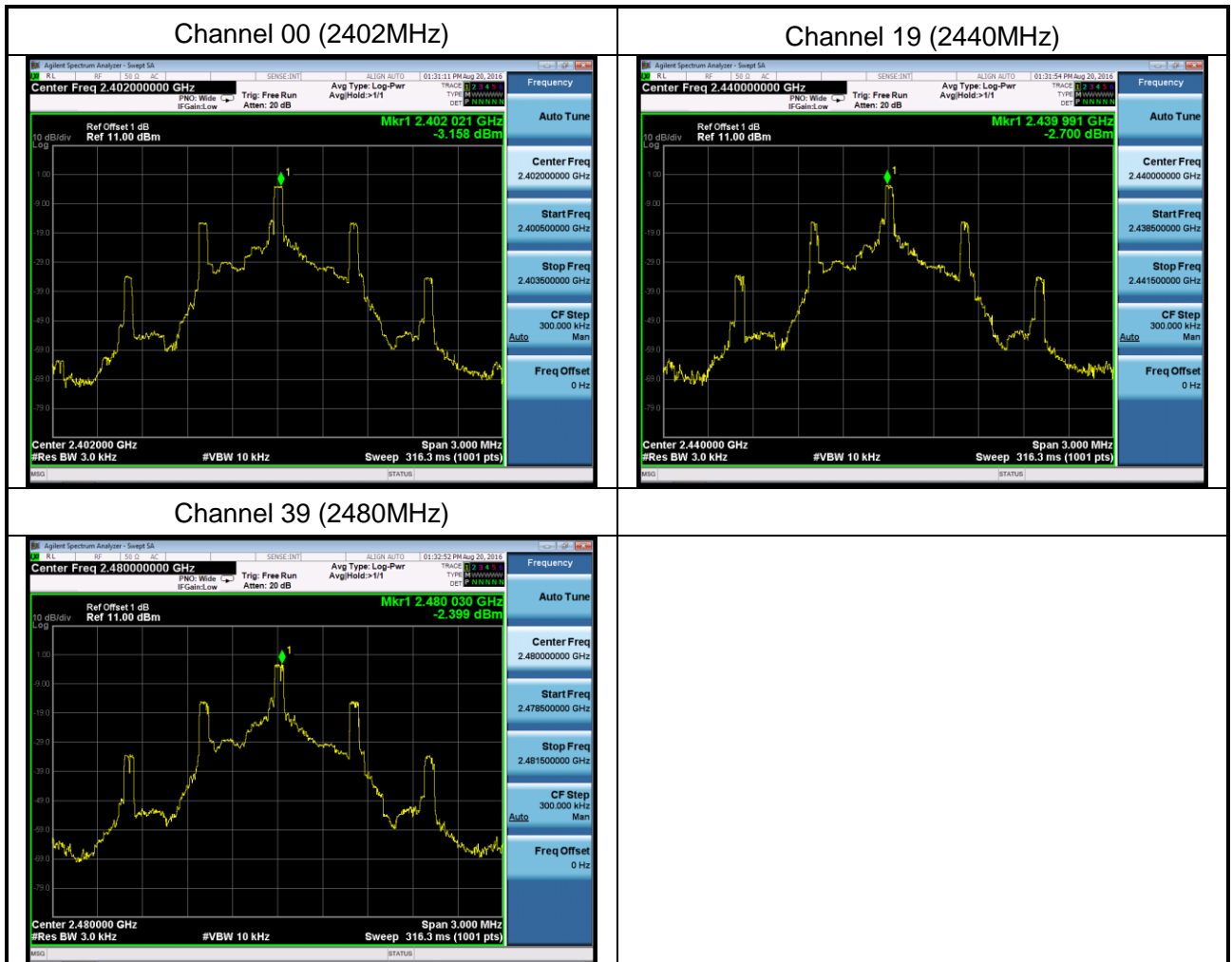



9. Band Edges Measurement

9.1 Test Limit

1. If the maximum peak conducted output power procedure was used to determine compliance as described in 11.9.1, then the peak output power measured in any 100 kHz bandwidth outside of the authorized frequency band shall be attenuated by at least 20 dB relative to the maximum.
2. If maximum conducted (average) output power was used to determine compliance as described in 11.9.2, then the peak power in any 100 kHz bandwidth outside of the authorized frequency band shall be attenuated by at least 30 dB relative to the maximum in-band peak PSD level in 100 kHz (i.e., 30 dBc).

9.2 in-band peak PSD level in 100 kHz (i.e., 20 dBc). Test Procedure

KDB 558074 D01v03r05 – Section 12.2.4 (peak power measurements)

KDB 558074 D01v03r05 – Section 12.2.5 (average power measurements)

9.3 Test Setting

Peak Measurements above 1GHz

1. Analyzer center frequency was set to the frequency of the radiated spurious emission of interest
2. RBW = 1MHz
3. VBW = 3MHz
4. Detector = peak
5. Sweep time = auto couple
6. Trace mode = max hold
7. Trace was allowed to stabilize

Average Measurements above 1GHz

7.8.3. Average Field Strength Measurements

1. Analyzer center frequency was set to the frequency of the radiated spurious emission of interest
2. RBW = 1MHz
3. VBW $\geq 1/T$
4. De As an alternative, the instrument may be set to linear detector mode. Ensure that video filtering is applied in linear voltage domain (rather than in a log or dB domain). Some instruments require linear display mode in order to accomplish this. Others have a setting for Average-VBW Type, which can be set to "Voltage" regardless of the display mode
5. Detector = Peak
6. Sweep time = auto
7. Trace mode = max hold
8. Allow max hold to run for at least 50 times (1/duty cycle) traces



9.4 Test Setup Layout

Radiated

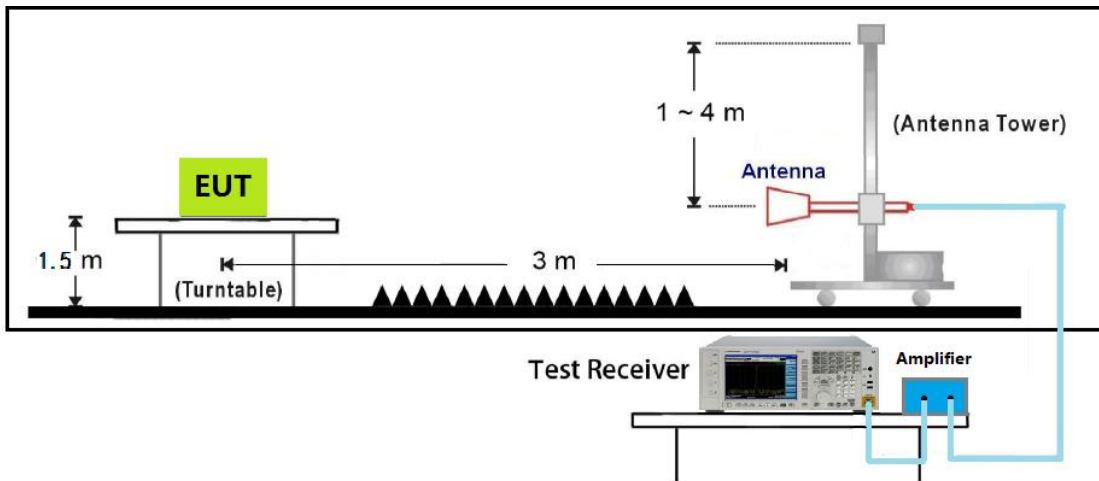

Conducted

Spectrum Analyzer

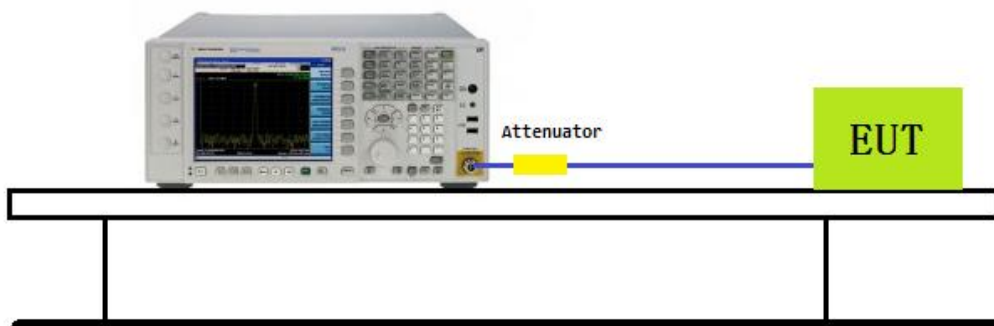

**9.5 Measurement Equipment**

Instrument/Ancillary	Manufacturer	Model No.	Serial No.	Calibration Date	Valid Date.
EMI Test Receiver	R&S	ESCI	101183	2016.03.28	2017.03.29
Spectrum Analyzer	N9010A	Agilent	MY53400169	2015.11.11	2016.11.11
Spectrum Analyzer	R&S	FSP40	100324	2016.03.23	2017.03.24
H64 Preamplifier	HP	8447F	3113A05582	2016.03.24	2017.03.23
Preamplifier	songyi	EM330	60618	2016.03.29	2017.03.28
Preamplifier	Agilent	8449B	3008A02342	2016.03.29	2017.03.28
Preamplifier	COM-POWER	PA-840	711885	2016.03.29	2017.03.28
Bilog Antenna	Sunol Science	JB1	A072414-1	2016.04.22	2017.04.21
Broad-Band Horn Antenna	Schwarzbeck	BBHA9120D	9120D-619	2016.04.20	2017.04.19
Broad-Band Horn Antenna	Schwarzbeck	BBHA9170	9170-347	2016.04.20	2017.04.19
Temperature/ Humidity Meter	Zhicheng	ZC1-11	CEP-TH-002	2016.03.31	2017.03.30



9.6 Test Result and Data

Site: AC102	Time: 2016/08/22 - 13:06
Limit: FCC_Part15.209_RE(3m)	Margin: 0
Probe: N/A	Polarity: Vertical
EUT: 001	Power:AC 120V/60Hz
Note: Mode 1: Transmit BLE at 2402MHz	

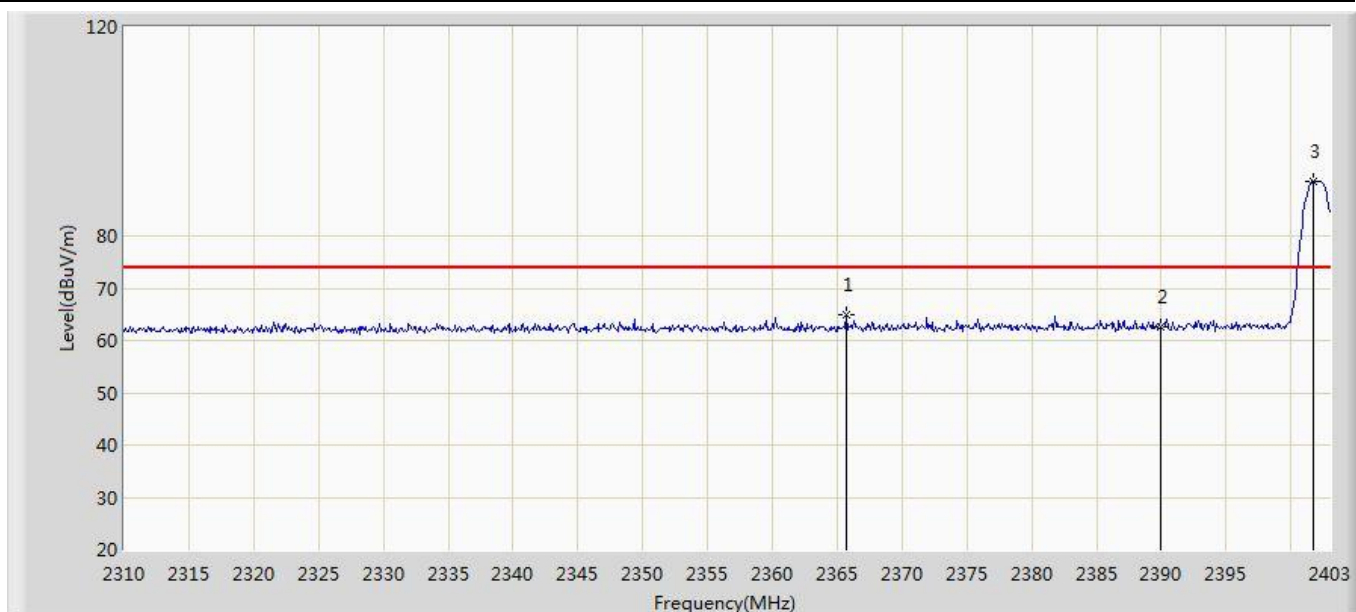

No	Mark	Frequency (MHz)	Measure Level (dBuV/m)	Reading Level (dBuV)	Over Limit (dB)	Limit (dBuV/m)	Factor (dB)	Type
1		2365.707	64.860	31.848	-9.140	74.000	33.013	PK
2		2390.000	62.634	29.523	-11.366	74.000	33.111	PK
3	*	2401.698	90.401	57.242	N/A	N/A	33.159	PK

Note: Measure Level (dBμV/m) = Reading Level (dBμV) + Factor (dB)

Factor (dB) = Cable Loss (dB) + Antenna Factor (dB/m)



Site: AC102	Time: 2016/08/22 - 13:13
Limit: FCC_Part15.209_RE(3m)	Margin: 0
Probe: N/A	Polarity: Vertical
EUT: 001	Power:AC 120V/60Hz
Note: Mode 1: Transmit BLE at 2402MHz	

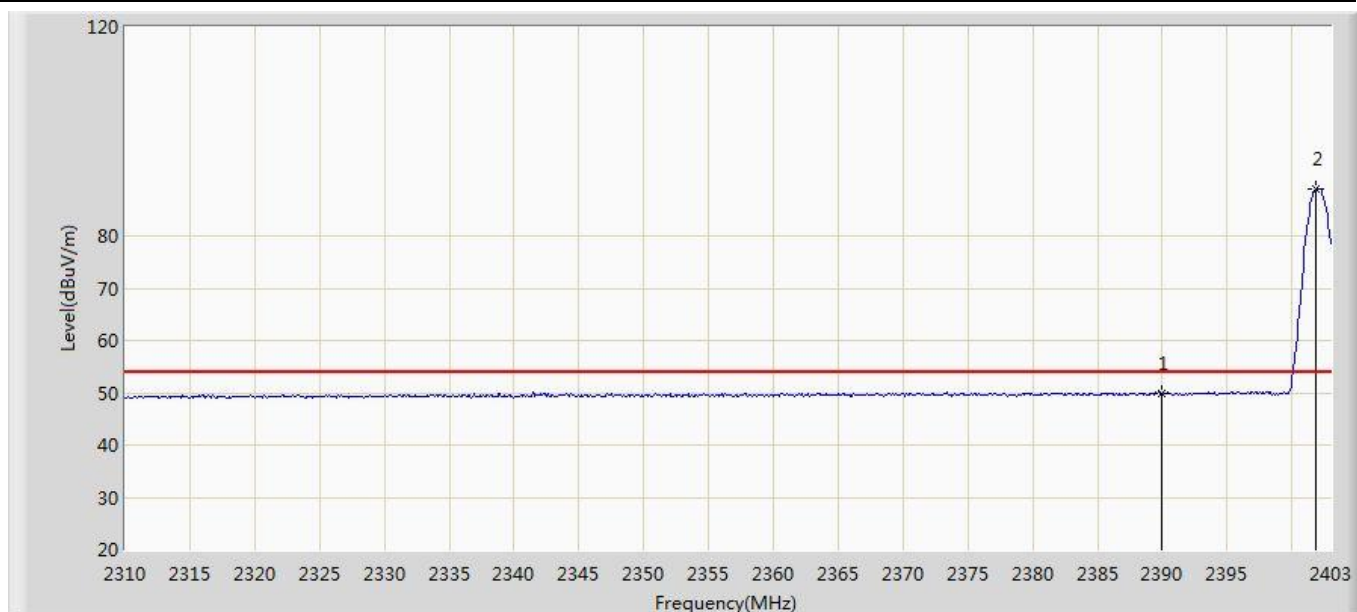

No	Mark	Frequency (MHz)	Measure Level (dBuV/m)	Reading Level (dBuV)	Over Limit (dB)	Limit (dBuV/m)	Factor (dB)	Type
1		2390.000	49.871	16.760	-4.129	54.000	33.111	AV
2	*	2401.884	89.023	55.863	N/A	N/A	33.160	AV

Note: Measure Level (dBμV/m) = Reading Level (dBμV) + Factor (dB)

Factor (dB) = Cable Loss (dB) + Antenna Factor (dB/m)



Site: AC102	Time: 2016/08/22 - 13:17
Limit: FCC_Part15.209_RE(3m)	Margin: 0
Probe: N/A	Polarity: Horizontal
EUT: 001	Power:AC 120V/60Hz
Note: Mode 1: Transmit BLE at 2402MHz	

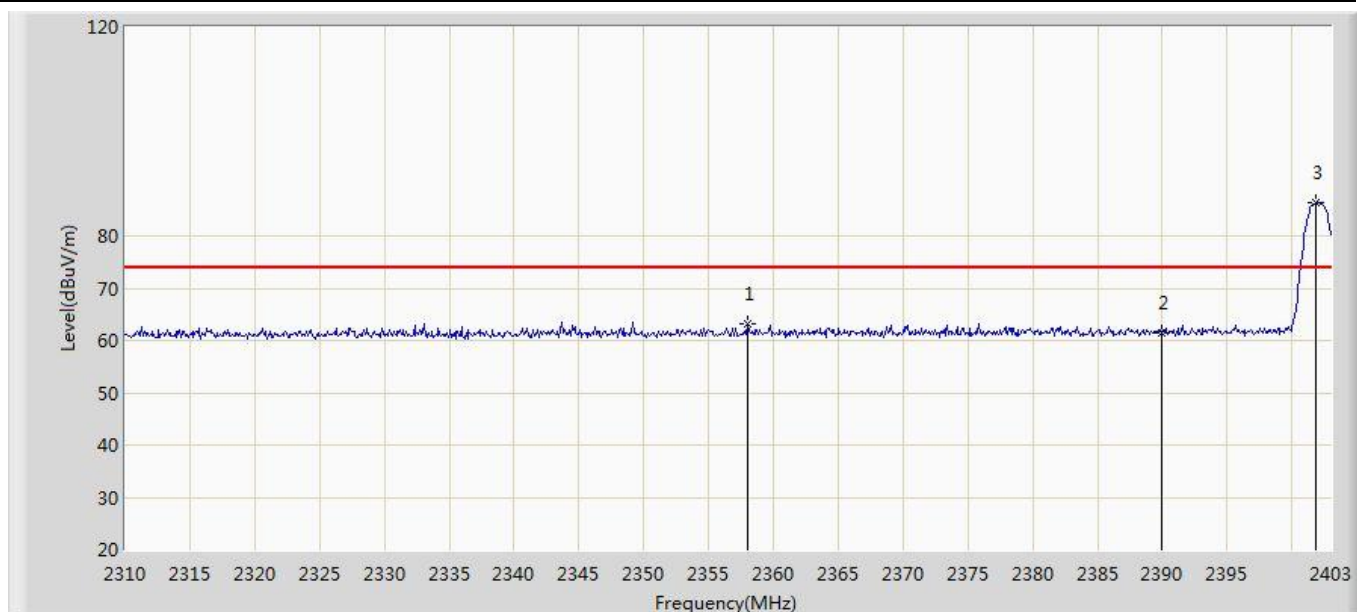

No	Mark	Frequency (MHz)	Measure Level (dBuV/m)	Reading Level (dBuV)	Over Limit (dB)	Limit (dBuV/m)	Factor (dB)	Type
1		2357.988	63.218	30.238	-10.782	74.000	32.980	PK
2		2390.000	61.574	28.463	-12.426	74.000	33.111	PK
3	*	2401.884	86.323	53.163	N/A	N/A	33.160	PK

Note: Measure Level (dBμV/m) = Reading Level (dBμV) + Factor (dB)

Factor (dB) = Cable Loss (dB) + Antenna Factor (dB/m)



Site: AC102	Time: 2016/08/22 - 13:23
Limit: FCC_Part15.209_RE(3m)	Margin: 0
Probe: N/A	Polarity: Horizontal
EUT: 001	Power:AC 120V/60Hz
Note: Mode 1: Transmit BLE at 2402MHz	

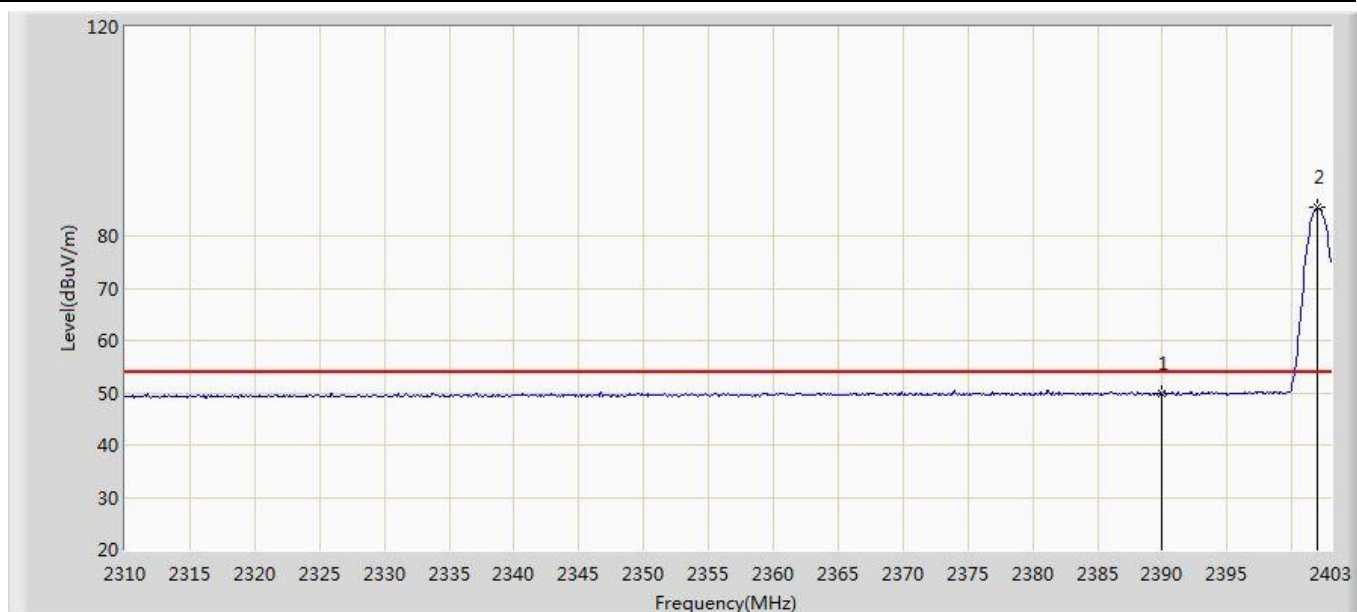

No	Mark	Frequency (MHz)	Measure Level (dBuV/m)	Reading Level (dBuV)	Over Limit (dB)	Limit (dBuV/m)	Factor (dB)	Type
1		2390.000	49.806	16.695	-4.194	54.000	33.111	AV
2	*	2401.977	85.376	52.216	N/A	N/A	33.161	AV

Note: Measure Level (dBμV/m) = Reading Level (dBμV) + Factor (dB)

Factor (dB) = Cable Loss (dB) + Antenna Factor (dB/m)



Site: AC102	Time: 2016/08/22 - 13:24
Limit: FCC_Part15.209_RE(3m)	Margin: 0
Probe: N/A	Polarity: Horizontal
EUT: 001	Power:AC 120V/60Hz
Note: Mode 1: Transmit BLE at 2480MHz	

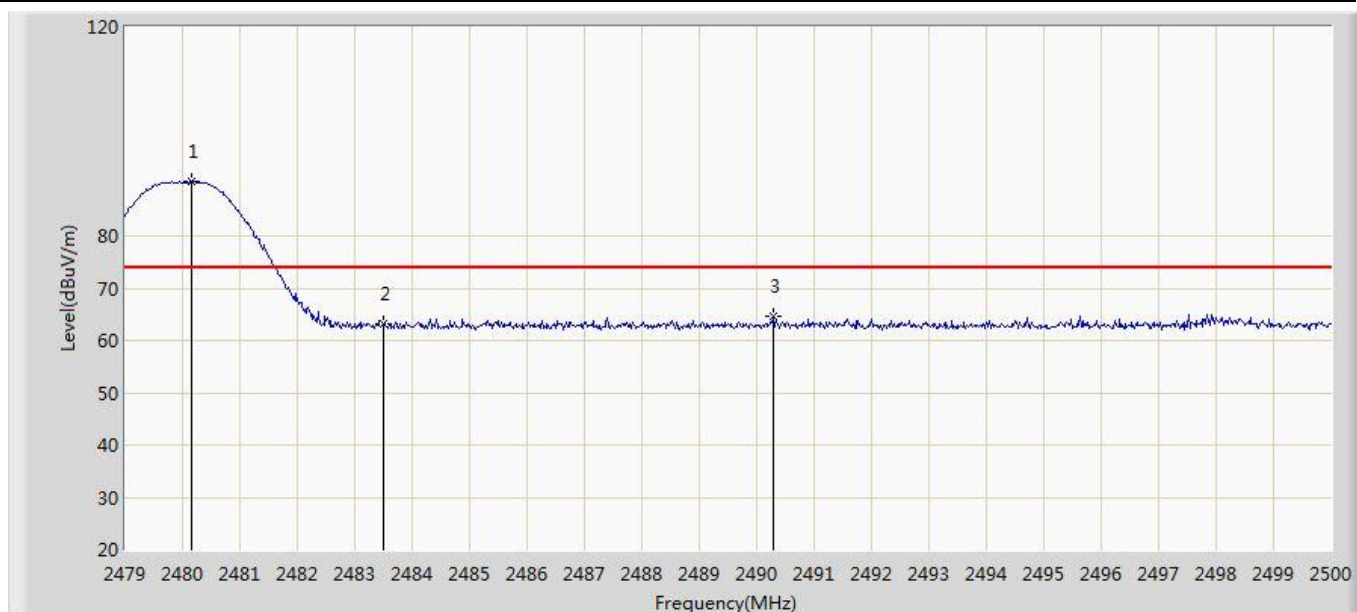

No	Mark	Frequency (MHz)	Measure Level (dBuV/m)	Reading Level (dBuV)	Over Limit (dB)	Limit (dBuV/m)	Factor (dB)	Type
1	*	2480.155	90.372	56.893	N/A	N/A	33.479	PK
2		2483.500	63.133	29.641	-10.867	74.000	33.493	PK
3		2490.298	64.595	31.075	-9.405	74.000	33.520	PK

Note: Measure Level (dBμV/m) = Reading Level (dBμV) + Factor (dB)

Factor (dB) = Cable Loss (dB) + Antenna Factor (dB/m)



Site: AC102	Time: 2016/08/22 - 13:29
Limit: FCC_Part15.209_RE(3m)	Margin: 0
Probe: N/A	Polarity: Horizontal
EUT: 001	Power:AC 120V/60Hz
Note: Mode 1: Transmit BLE at 2480MHz	

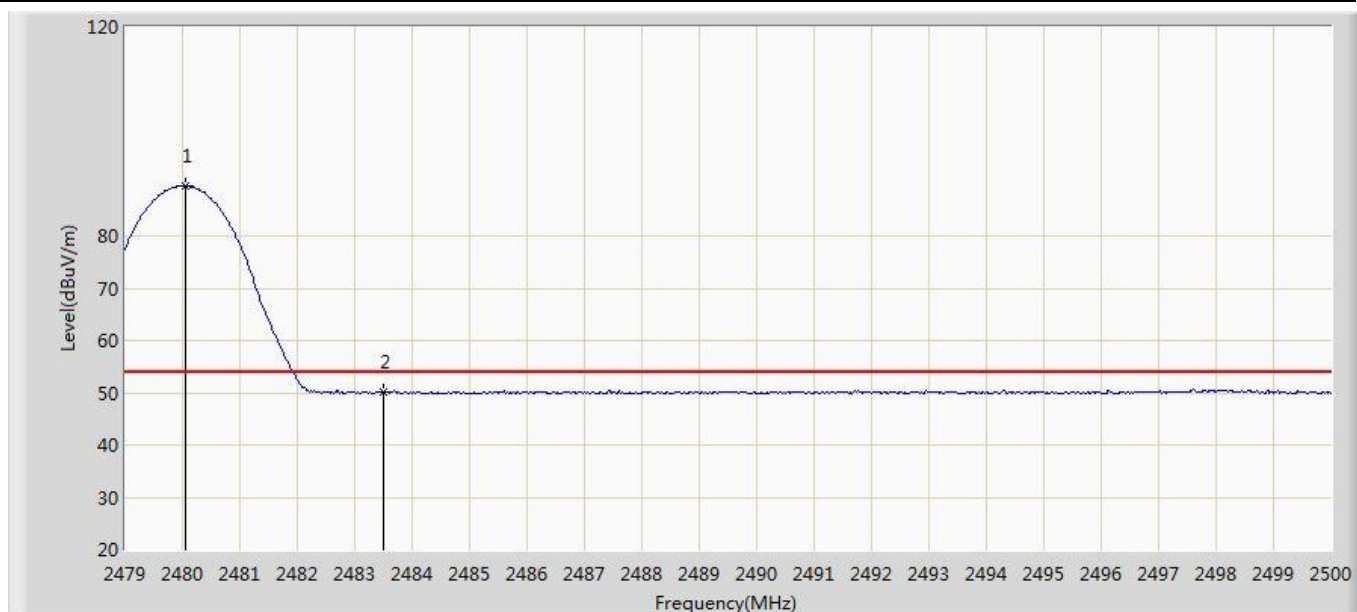

No	Mark	Frequency (MHz)	Measure Level (dBuV/m)	Reading Level (dBuV)	Over Limit (dB)	Limit (dBuV/m)	Factor (dB)	Type
1	*	2480.050	89.516	56.037	N/A	N/A	33.479	AV
2		2483.500	50.005	16.513	-3.995	54.000	33.493	AV

Note: Measure Level (dBμV/m) = Reading Level (dBμV) + Factor (dB)

Factor (dB) = Cable Loss (dB) + Antenna Factor (dB/m)



Site: AC102	Time: 2016/08/22 - 13:29
Limit: FCC_Part15.209_RE(3m)	Margin: 0
Probe: N/A	Polarity: Vertical
EUT: 001	Power:AC 120V/60Hz
Note: Mode 1: Transmit BLE at 2480MHz	

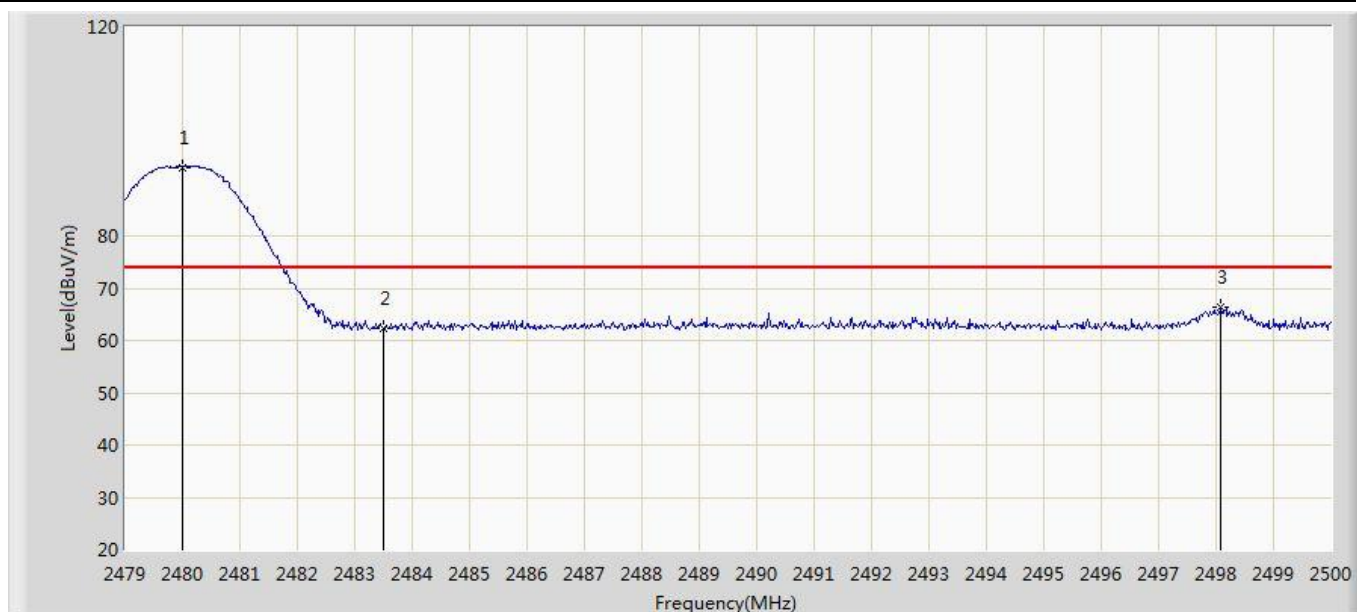

No	Mark	Frequency (MHz)	Measure Level (dBuV/m)	Reading Level (dBuV)	Over Limit (dB)	Limit (dBuV/m)	Factor (dB)	Type
1	*	2480.008	93.152	59.674	N/A	N/A	33.478	PK
2		2483.500	62.448	28.956	-11.552	74.000	33.493	PK
3		2498.089	66.449	32.899	-7.551	74.000	33.550	PK

Note: Measure Level (dBμV/m) = Reading Level (dBμV) + Factor (dB)

Factor (dB) = Cable Loss (dB) + Antenna Factor (dB/m)



Site: AC102	Time: 2016/08/22 - 13:32
Limit: FCC_Part15.209_RE(3m)	Margin: 0
Probe: N/A	Polarity: Vertical
EUT: 001	Power:AC 120V/60Hz
Note: Mode 1: Transmit BLE at 2480MHz	

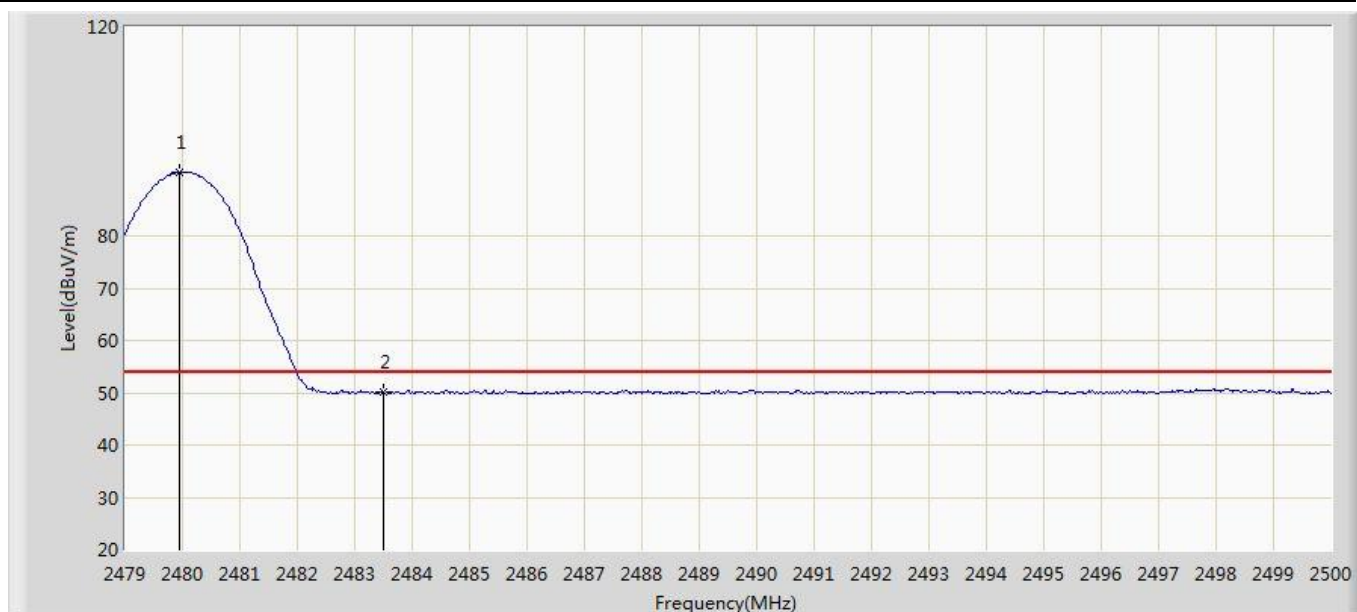

No	Mark	Frequency (MHz)	Measure Level (dBuV/m)	Reading Level (dBuV)	Over Limit (dB)	Limit (dBuV/m)	Factor (dB)	Type
1	*	2479.945	92.151	58.673	N/A	N/A	33.478	AV
2		2483.500	50.147	16.655	-3.853	54.000	33.493	AV

Note: Measure Level (dBμV/m) = Reading Level (dBμV) + Factor (dB)

Factor (dB) = Cable Loss (dB) + Antenna Factor (dB/m)



Band Edge (20dBc RF Conducted Measurement)

Mode 1: Transmit by BLE (2402MHz)





Mode 1: Transmit by BLE (2440MHz)



Mode 1: Transmit by BLE (2480MHz)

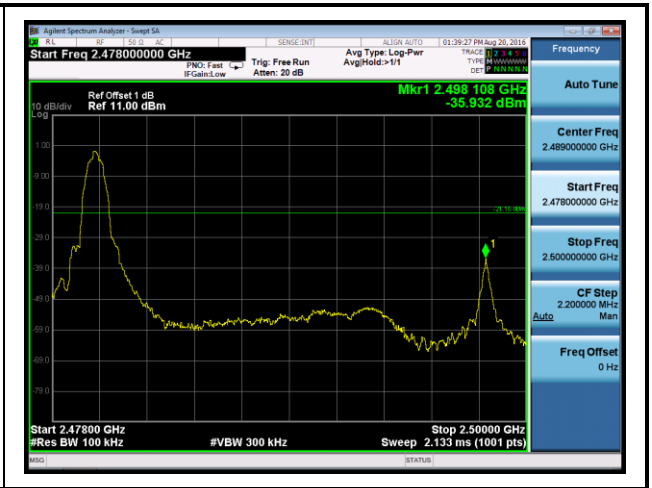



10. Restricted Bands of Operation

Only spurious emissions are permitted in any of the frequency bands listed below:

MHz	MHz	MHz	GHz
0.09000 – 0.11000	16.42000 – 16.42300	399.9 – 410.0	4.500 – 5.250
0.49500 – 0.505**	16.69475 – 16.69525	608.0 – 614.0	5.350 – 5.460
2.17350 – 2.19050	16.80425 – 16.80475	960.0 – 1240.0	7.250 – 7.750
4.12500 – 4.12800	25.50000 – 25.67000	1300.0 – 1427.0	8.025 – 8.500
4.17725 – 4.17775	37.50000 – 38.25000	1435.0 – 1626.5	9.000 – 9.200
4.20725 – 4.20775	73.00000 – 74.60000	1645.5 – 1646.5	9.300 – 9.500
6.21500 – 6.21800	74.80000 – 75.20000	1660.0 – 1710.0	10.600 – 12.700
6.26775 – 6.26825	108.00000 – 121.94000	1718.8 – 1722.2	13.250 – 13.400
6.31175 – 6.31225	123.00000 – 138.00000	2200.0 – 2300.0	14.470 – 14.500
8.29100 – 8.29400	149.90000 – 150.05000	2310.0 – 2390.0	15.350 – 16.200
8.36200 – 8.36600	156.52475 – 156.52525	2483.5 – 2500.0	17.700 – 21.400
8.37625 – 8.38675	156.70000 – 156.90000	2655.0 – 2900.0	22.010 – 23.120
8.41425 – 8.41475	162.01250 – 167.17000	3260.0 – 3267.0	23.600 – 24.000
12.29000 – 12.29300	167.72000 – 173.20000	3332.0 – 3339.0	31.200 – 31.800
12.51975 – 12.52025	240.00000 – 285.00000	3345.8 – 3358.0	36.430 – 36.500
12.57675 – 12.57725	322.00000 – 335.40000	3600.0 – 4400.0	Above 38.6
13.36000 – 13.41000			

** : Until February 1, 1999, this restricted band shall be 0.490-0.510 MHz

10.1 Labeling Requirement

The device shall bear the following statement in a conspicuous location on the device:

This device complies with part 15 of the FCC Rules. Operation is subject to the following two conditions:

- (1) This device may not cause harmful interference, and
- (2) this device must accept any interference received, including interference that may cause undesired operation.