



FCC TEST REPORT

According to

CFR47 §15.247

Applicant	: Snapchat, Inc.
Address	: 63 Market Streets, Venice, CA 90291, USA
Manufacturer	: Weifang GoerTek Electronics Co.,Ltd
Address	: Gaoxin 2 Road,Free Trade Zone,Weifang,Shandong,261205,P.R.China
Equipment	: Spectacles
Model No.	: 001
Brand	: Snapchat
FCC ID	: 2AIRN-001

- The test result refers exclusively to the test presented test model / sample.
- Without written approval of **CerpPASS Technology (Suzhou) Co., Ltd.** the test report shall not be reproduced exc- ept in full.

I HEREBY CERTIFY THAT :

The measurements shown in this test report were made in accordance with the procedures given in **ANSI C63.10 – 2013** and the energy emitted by this equipment was **passed**.

CISPR PUB. 22 and FCC Part 15 in both radiated and conducted emission class B limits. Testing was carried out on Aug.20th,2016~Aug.31th,2016 at **CerpPASS Technology (Suzhou) Co., Ltd.**

Laboratory Accreditation:

Approved by:

Miro Chueh
EMC/RF Manager

<input type="checkbox"/>	CerpPASS Technology Corporation Test Laboratory	
	NVLAP LAB Code:	200954-0
	TAF LAB Code:	1439
<input checked="" type="checkbox"/>	CerpPASS Technology (SuZhou) Co., Ltd.	
	NVLAP LAB Code:	200814-0
	CNAS LAB Code:	L5515



History of this Test Report

Attachment No.	Version	Date	Description
SEFI1608091	Rev 01	Sept.01, 2016	Initial release



Table of Contents

1. Report of Measurements and Examinations.....	5
1.1 List of Measurements and Examinations	5
2. Test Configuration of Equipment under Test.....	6
2.1 Feature of Equipment under Test	6
2.2 Carrier Frequency of Channels	7
2.3 Power Setting Levels.....	7
2.4 Duty cycle	8
2.5 Test Manner.....	9
2.6 Description of Test System.....	10
2.7 Configuration of Tested System	10
2.8 General Information of Test.....	11
2.9 Measurement Uncertainty	11
3. Antenna Requirements	12
3.1 Standard Applicable.....	12
3.2 Antenna Construction and Directional Gain	12
4. Test of Conducted Emission	13
4.1 Test Limit	13
4.2 Test Procedures.....	13
4.3 Typical Test Setup	14
4.4 Measurement Equipment	14
4.5 Test Result and Data	15
5. Test of Radiated Emission.....	17
5.1 Test Limit	17
5.2 Test Procedures.....	17
5.3 Test Setting	18
5.4 Typical Test Setup	19
5.5 Measurement Equipment	21
5.6 Test Result and Data	22
6. Maximum Output Power	30
6.1 Test Limit	30
6.2 Test Procedure	30
6.3 Test Setup Layout.....	30
6.4 Measurement Equipment	30
6.5 Test Result and Data	31
7. Occupied Bandwidth	33
7.1 Test Limit	33
7.2 Test Procedures.....	33
7.3 Test Setup Layout.....	33
7.4 Measurement Equipment	33
7.5 Test Result and Data	34
8. Power Spectral Density.....	37
8.1 Test Limit	37



8.2 Test Procedure 37

8.3 Test Setup Layout..... 37

8.4 Measurement Equipment 37

8.5 Test Result and Data 38

9. Band Edges Measurement..... 41

9.1 Test Limit 41

9.2 in-band peak PSD level in 100 kHz (i.e., 20 dBc).Test Procedure 41

9.3 Test Setting 41

9.4 Test Setup Layout..... 42

9.5 Measurement Equipment 43

9.6 Test Result and Data 44

10. Restricted Bands of Operation..... 74

10.1 Labeling Requirement 74



1. Report of Measurements and Examinations

1.1 List of Measurements and Examinations

Performed Test Item	Normative References	Test Performed	Deviation	Result
Conducted Emission	FCC CFR Title 47 Part 15 Subpart C: 2014 Section 15.207	Yes	N/A	Pass
Radiated Emission	FCC CFR Title 47 Part 15 Subpart C: 2014 Section 15.209 RSS-Gen Issue 4 November 2014 Section 6.13	Yes	No	Pass
RF Antenna Conducted Spurious	FCC CFR Title 47 Part 15 Subpart C: 2014 Section 15.247(d) RSS-247 Issue 1 May 2015 Section 5.5	Yes	No	Pass
Radiated Emission Band Edge	FCC CFR Title 47 Part 15 Subpart C: 2014 15.247(d) RSS-247 Issue 1 May 2015 Section 5.5	Yes	No	Pass
Operation Frequency Range of 20dB Bandwidth	FCC CFR Title 47 Part 15 Subpart C: 2014 15.215(c)	Yes	No	Pass
Occupied Bandwidth	FCC CFR Title 47 Part 15 Subpart C: 2014 Section 15.247(a)(2) RSS-247 Issue 1 May 2015 Section 5.2(1)	Yes	No	Pass
Output Power	FCC CFR Title 47 Part 15 Subpart C: 2014 Section 15.247(b)(3) RSS-247 Issue 1 May 2015 Section 5.4(4)	Yes	No	Pass
Power Spectral Density	FCC CFR Title 47 Part 15 Subpart C: 2014 Section 15.247(e) RSS-247 Issue 1 May 2015 Section 5.2(2)	Yes	No	Pass



2. Test Configuration of Equipment under Test

2.1 Feature of Equipment under Test

Product name	Spectacles
Model No.	001
Power supply cable	Shielded, 1.0m

WIFI Module	SP-KL1DX-G
Spreading	802.11b: DSSS 802.11g / n: OFDM
Frequency Range	802.11b/g/n(20MHz): 2412-2462MHz
Number of Channels	802.11b/g/n (20MHz):11
Data Rate	802.11b: 11, 5.5, 2, 1 Mbps 802.11g: 54, 48, 36, 24, 18, 12, 9, 6 Mbps 802.11n: up to 300Mbps



2.2 Carrier Frequency of Channels

For 2.4G 802.11b, 802.11g, 802.11n (20MHz)

Channel	Frequency(MHz)	Channel	Frequency(MHz)
01	2412	07	2442
02	2417	08	2447
03	2422	09	2452
04	2427	10	2457
05	2432	11	2462
06	2437	---	---

2.3 Power Setting Levels

Mode	Frequency (MHz)	putty Setting
802.11b	2412	17
	2437	17
	2462	17
802.11g	2412	13
	2437	13
	2462	13
802.11n(20MHz)	2412	12
	2437	12
	2462	12

Note: Teraterm software is used for power transmission control offered by the manufactory.



2.4 Duty cycle

Test Item	Duty cycle
-----------	------------

Mode	Frequency (MHz)	Measurement (%)
802.11b	2437	92.0
802.11g	2437	69.0
802.11n(20MHz)	2437	66.8

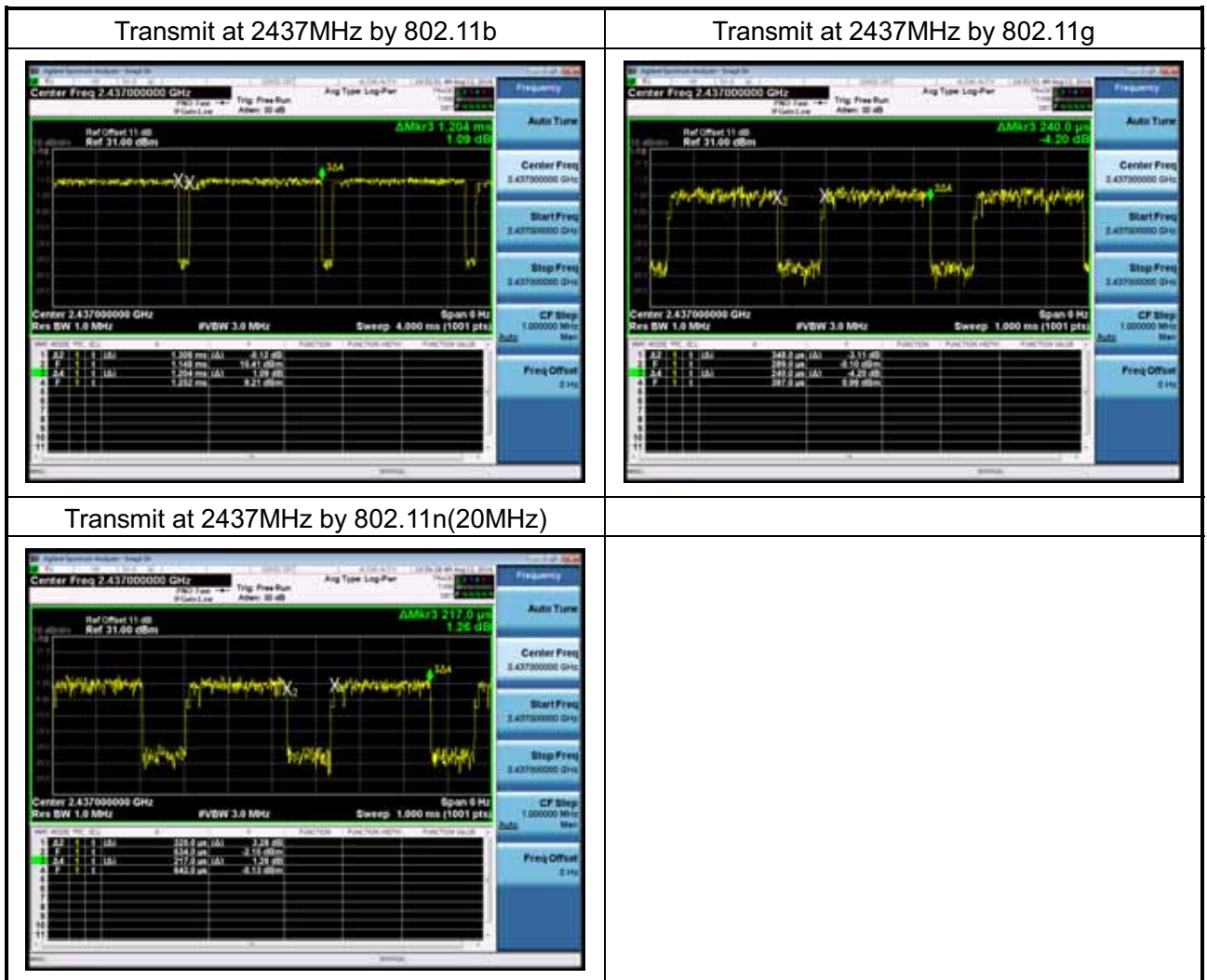



2.5 Test Manner

Test Manner	
1	During testing, the interface cables and equipment positions were varied according to C63.10.
2	Adjust the EUT at the test mode and the test channel. Then test.
Test mode	
1	Transmit by 802.11b
2	Transmit by 802.11g
3	Transmit by 802.11n (20MHz)



2.6 Description of Test System

No	Device	Manufacturer	Model No.	Description
1	Notebook PC	SONY	PCG-71811P	N/A

2.7 Configuration of Tested System

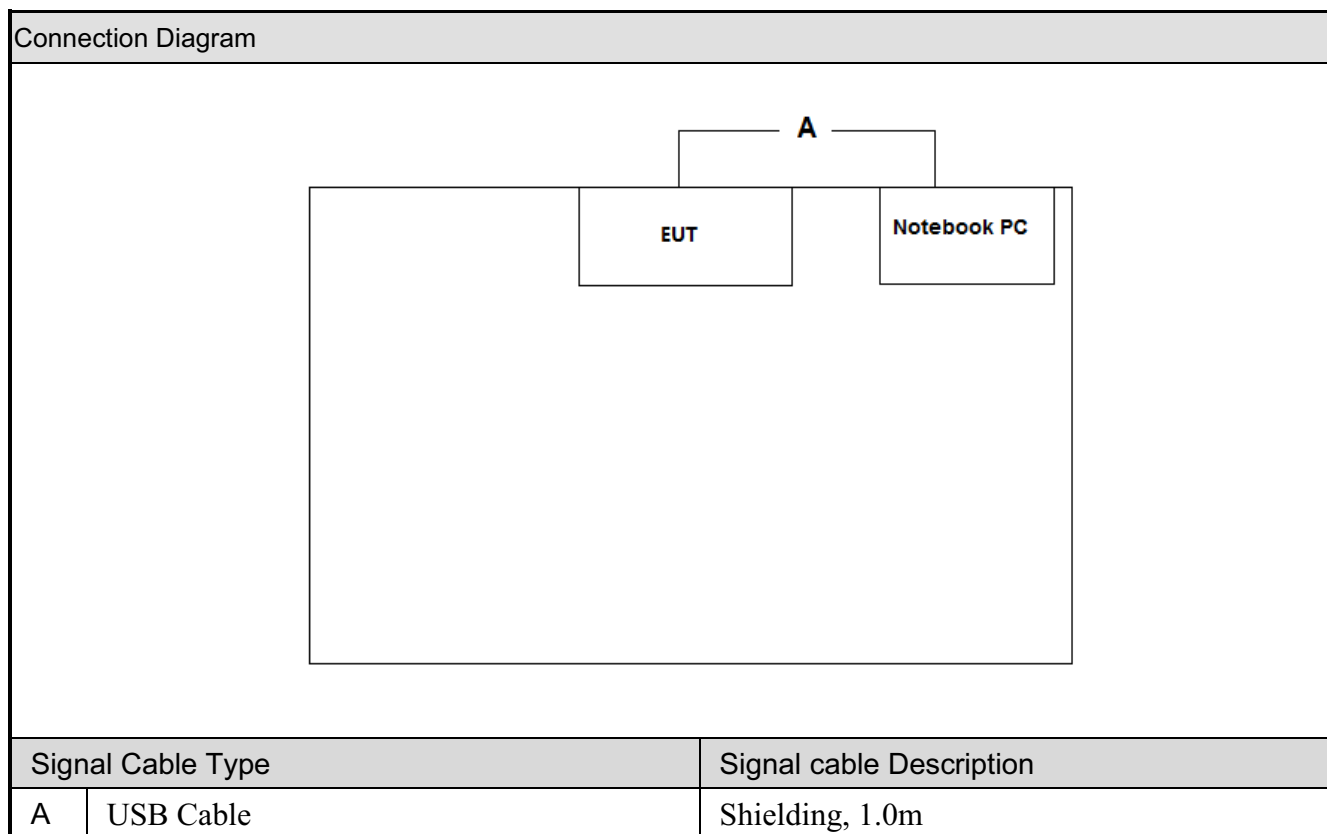



2.8 General Information of Test

Test Site:	CerpPASS Technology (Suzhou) Co., Ltd
Performand Location :	No.66,Tangzhuang Road, Suzhou Industrial Park, Jiangsu 215006, China
NVLAP LAB Code :	200814-0
FCC Registration Number :	916572, 331395
IC Registration Number :	7290A-1, 7290A-2

2.9 Measurement Uncertainty

Measurement Item	Measurement Frequency	Polarization	Uncertainty
Conducted Emission	9 kHz ~ 30 MHz	LINE/NEUTRAL	±2.71 dB
Radiated Emission	30 MHz ~ 25GHz	Vertical	±4.11 dB
		Horizontal	±4.10 dB
Occupied Bandwidth	---	---	±7500 Hz
Maximum Peak Output Power	---	---	±1.4 dB
Power Spectral Density	---	---	±2.2 dB



3. Antenna Requirements

3.1 Standard Applicable

For intentional device, according to FCC 47 CFR Section 15.203, an intentional radiator shall be designed to ensure that no antenna other than that furnished by the responsible party shall be used with the device.

And according to FCC 47 CFR Section 15.247 (b), if transmitting antennas of directional gain greater than 6dBi are used, the power shall be reduced by the amount in dB that the directional gain of the antenna exceeds 6dBi.

3.2 Antenna Construction and Directional Gain

Antenna	Manufacturer	Model No.	Peak Gain
Monopole Antenna	Weifang GoerTek Electronics Co.,Ltd	V03-1631	0.04dBi for2.4 GHz ~2.5 GHz



4. Test of Conducted Emission

4.1 Test Limit

Conducted Emissions were measured from 150 kHz to 30 MHz with a bandwidth of 9 KHz on the 120 VAC power and return leads of the EUT according to the methods defined in ANSI C63.10-2013. The EUT was placed on a nonmetallic stand in a shielded room 0.8 meters above the ground plane as shown in section 6.2.2. The interface cables and equipment positioning were varied within limits of reasonable applications to determine the position produced maximum conducted emissions.

Frequency (MHz)	Quasi Peak (dB μ V)	AVG (dB μ V)
0.15 – 0.5	66-56*	56-46*
0.5 – 5.0	56	46
5.0 – 30.0	60	50

*Decreases with the logarithm of the frequency.

4.2 Test Procedures

The EUT was setup according to ANSI C63.10, 2013. The EUT was placed on a platform of nominal size, 1 m by 1.5 m, raised 80 cm above the conducting ground plane. The vertical conducting plane was located 40 cm to the rear of the EUT. All other surfaces of EUT were at least 80 cm from any other grounded conducting surface. The EUT and simulators are connected to the main power through a line impedance stabilization network (LISN). The LISN provides a 50 ohm /50uH coupling impedance for the measuring equipment. The peripheral devices are also connected to the main power through a LISN. (Please refer to the block diagram of the test setup and photographs) Each current-carrying conductor of the EUT power cord, except the ground (safety) conductor, was individually connected through a LISN to the input power source. The excess length of the power cord between the EUT and the LISN receptacle were folded back and forth at the center of the lead to form a bundle not exceeding 40 cm in length. Conducted emissions were investigated over the frequency range from 0.15MHz to 30MHz using a receiver bandwidth of 9kHz.



4.3 Typical Test Setup

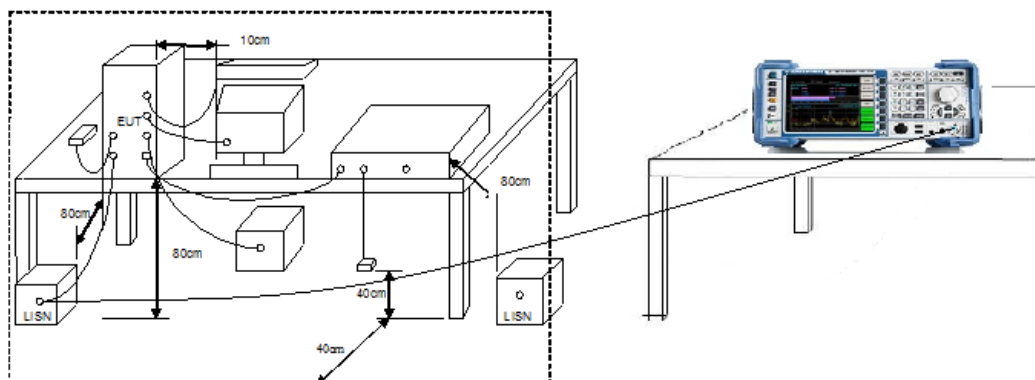

4.4 Measurement Equipment

Instrument	Manufacturer	Model No.	Serial No.	Calibration Date	Valid Date.
Test Receiver	R&S	ESCI	100565	2016.03.24	2017.03.23
AMN	R&S	ESH2-Z5	100182	2015.09.04	2016.09.03
Two-Line V-Network	R&S	ENV216	100325	2015.12.04	2016.12.03
ISN	FCC	FCC-TLISN-T2 -02	20379	2016.03.24	2017.03.23
ISN	FCC	FCC-TLISN-T4 -02	20380	2016.03.24	2017.03.23
ISN	FCC	FCC-TLISN-T8 -02	20381	2016.03.24	2017.03.23
ISN	TESEQ	ISN ST08	30175	2016.03.24	2017.03.23
Current Probe	R&S	EZ-17	100303	2016.04.04	2017.04.03
Passive Voltage Probe	R&S	ESH2-Z3	100026	2016.03.29	2017.03.28
Pulse Limiter	R&S	ESH3-Z2	100529	2016.03.29	2017.03.28
Temperature/ Humidity Meter	Zhicheng	ZC1-11	CEP-TH-004	2016.03.31	2017.03.30



4.5 Test Result and Data

Test Mode :	Mode 1: Normal Operation with wifi on		
AC Power :	AC 120V/60Hz	Phase :	LINE
Temperature :	22°C	Humidity :	50%
Pressure(mbar) :	1002	Date:	2016/08/31

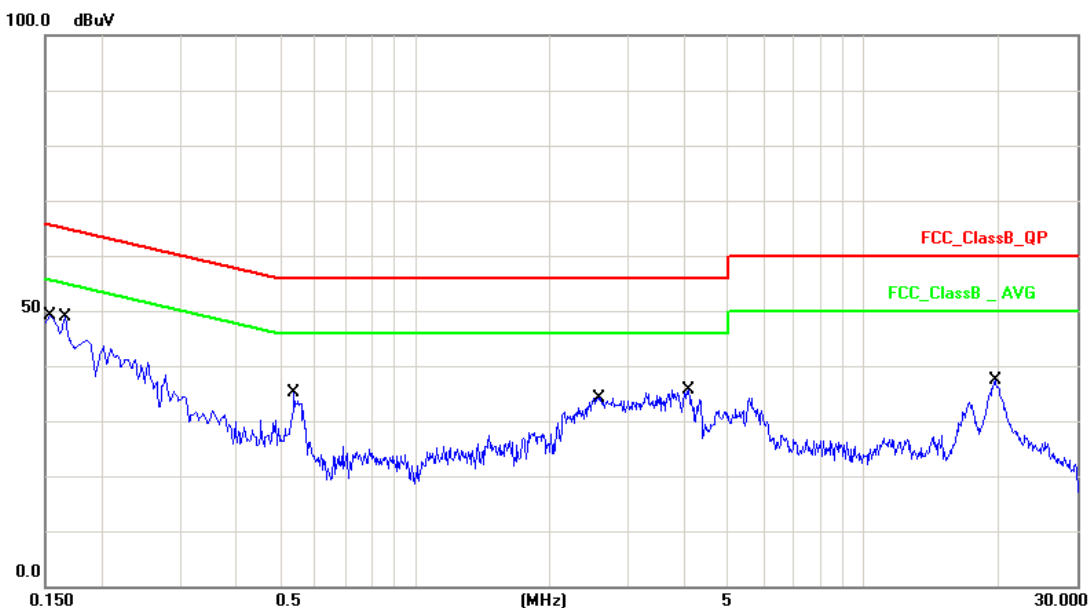

No.	Frequency (MHz)	Factor (dB)	Reading (dBuV)	Level (dBuV)	Limit (dBuV)	Margin (dB)	Detector
1	0.1539	10.13	35.25	45.38	65.78	-20.40	QP
2	0.1539	10.13	17.31	27.44	55.78	-28.34	AVG
3	0.1660	10.13	33.57	43.70	65.15	-21.45	QP
4	0.1660	10.13	14.47	24.60	55.15	-30.55	AVG
5	0.5380	10.16	20.37	30.53	56.00	-25.47	QP
6	0.5380	10.16	14.26	24.42	46.00	-21.58	AVG
7	2.5780	10.18	20.26	30.44	56.00	-25.56	QP
8	2.5780	10.18	14.26	24.44	46.00	-21.56	AVG
9	4.0780	10.20	16.15	26.35	56.00	-29.65	QP
10	4.0780	10.20	8.57	18.77	46.00	-27.23	AVG
11	19.7300	10.35	21.36	31.71	60.00	-28.29	QP
12	19.7300	10.35	15.57	25.92	50.00	-24.08	AVG

Note: Measurement Level = Reading Level + Correct Factor



Test Mode :	Mode 1: Normal Operation with wifi on		
AC Power :	AC 120V/60Hz	Phase :	NEUTRAL
Temperature :	22°C	Humidity :	50%
Pressure(mbar) :	1002	Date:	2016/08/31

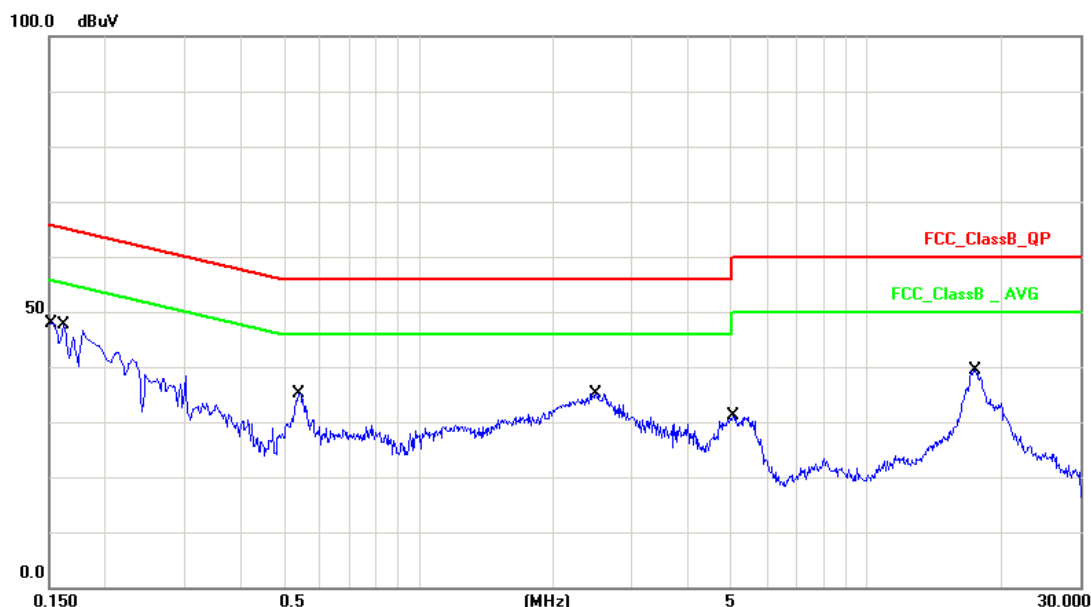

No.	Frequency (MHz)	Factor (dB)	Reading (dBuV)	Level (dBuV)	Limit (dBuV)	Margin (dB)	Detector
1	0.1500	10.13	35.15	45.28	65.99	-20.71	QP
2	0.1500	10.13	17.46	27.59	55.99	-28.40	AVG
3	0.1620	10.13	34.37	44.50	65.36	-20.86	QP
4	0.1620	10.13	17.48	27.61	55.36	-27.75	AVG
5	0.5420	10.15	23.02	33.17	56.00	-22.83	QP
6	0.5420	10.15	16.03	26.18	46.00	-19.82	AVG
7	2.4980	10.19	21.53	31.72	56.00	-24.28	QP
8	2.4980	10.19	15.82	26.01	46.00	-19.99	AVG
9	5.0380	10.26	14.30	24.56	60.00	-35.44	QP
10	5.0380	10.26	6.05	16.31	50.00	-33.69	AVG
11	17.5060	10.48	24.61	35.09	60.00	-24.91	QP
12	17.5060	10.48	18.95	29.43	50.00	-20.57	AVG

Note: Measurement Level = Reading Level + Correct Factor



5. Test of Radiated Emission

5.1 Test Limit

In any 100kHz bandwidth outside the frequency band in which the spread spectrum or digitally modulated intentional radiator is operating, the radio frequency power that is produced by the intentional radiator shall be at least 20dB below that in the 100kHz bandwidth within the band that contains the highest level of the desired power, based on either an RF conducted or a radiated measurement. If the transmitter measurement is based on the maximum conducted output power, the attenuation required under this paragraph shall be 30dB instead of 20dB. In addition, radiated emissions which fall in section 15.205(a) the restricted bands must also comply with the radiated emission limit specified in section 15.209(a).

FREQUENCIES(MHz)	FIELD STRENGTH (microvolts/meter)	MEASUREMENT DISTANCE(meters)
0.009~0.490	2400/F(kHz)	300
0.490~1.705	24000/F(kHz)	30
1.705~30.0	30	30
30~88	100	3
88~216	150	3
216~960	200	3
Above 960	500	3

5.2 Test Procedures

KDB 558074 D01v03r05 - Section 12.0 & Section 12.1



5.3 Test Setting

Quasi-Peak Measurements below 1GHz

1. Analyzer center frequency was set to the frequency of the radiated spurious emission of interest
2. Span was set greater than 1MHz
3. RBW = 120 kHz
4. Detector = CISPR quasi-peak
5. Sweep time = auto couple
6. Trace was allowed to stabilize

Peak Measurements above 1GHz

1. Analyzer center frequency was set to the frequency of the radiated spurious emission of interest
2. RBW = 1MHz
3. VBW = 3MHz
4. Detector = peak
5. Sweep time = auto couple
6. Trace mode = max hold
7. Trace was allowed to stabilize

Average Measurements above 1GHz

7.8.3. Average Field Strength Measurements

1. Analyzer center frequency was set to the frequency of the radiated spurious emission of interest
2. RBW = 1MHz
3. VBW $\geq 1/T$
4. De As an alternative, the instrument may be set to linear detector mode. Ensure that video filtering is applied in linear voltage domain (rather than in a log or dB domain). Some instruments require linear display mode in order to accomplish this. Others have a setting for Average-VBW Type, which can be set to "Voltage" regardless of the display mode
5. Detector = Peak
6. Sweep time = auto
7. Trace mode = max hold
8. Allow max hold to run for at least 50 times (1/duty cycle) traces



5.4 Typical Test Setup

9kHz~30MHz Test Setup

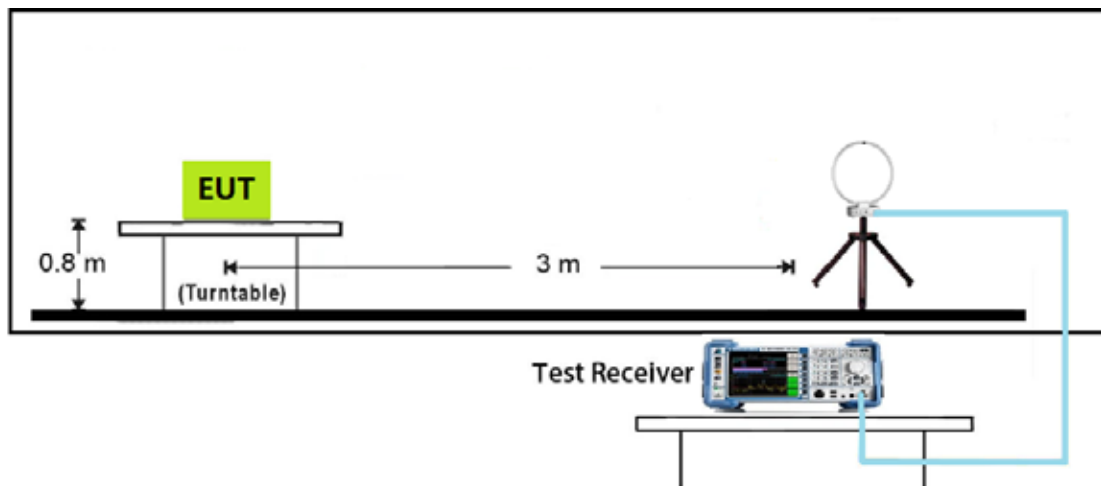

Below 1GHz Test Setup

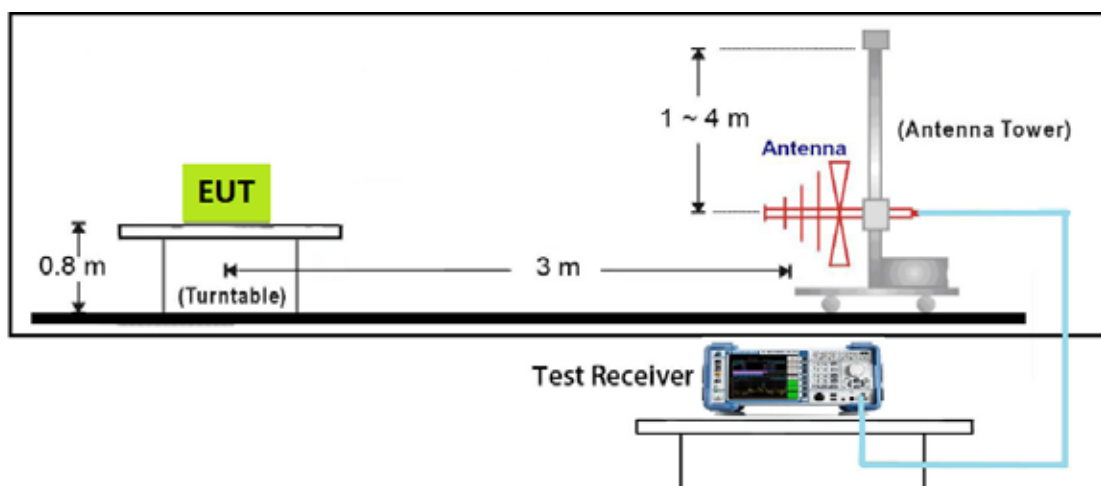



1GHz~18GHz Test Setup

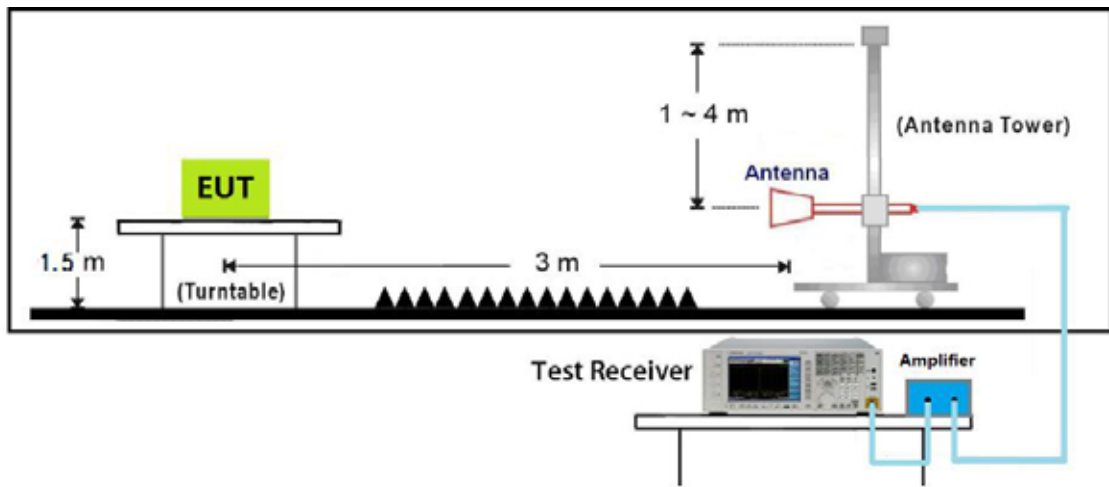

18GHz~40GHz Test Setup

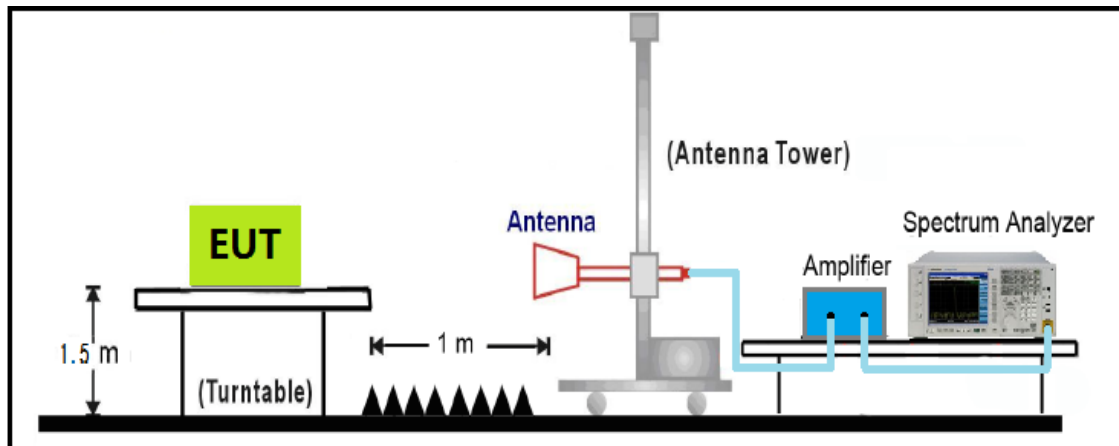

**5.5 Measurement Equipment**

Instrument/Ancillary	Manufacturer	Model No.	Serial No.	Calibration Date	Valid Date.
EMI Test Receiver	R&S	ESCI	101183	2016.03.28	2017.03.29
Spectrum Analyzer	N9010A	Agilent	MY53400169	2015.11.11	2016.11.11
Spectrum Analyzer	R&S	FSP40	100324	2016.03.23	2017.03.24
H64 Preamplifier	HP	8447F	3113A05582	2016.03.24	2017.03.23
Preamplifier	songyi	EM330	60618	2016.03.29	2017.03.28
Preamplifier	Agilent	8449B	3008A02342	2016.03.29	2017.03.28
Preamplifier	COM-POWER	PA-840	711885	2016.03.29	2017.03.28
Bilog Antenna	Sunol Science	JB1	A072414-1	2016.04.22	2017.04.21
Broad-Band Horn Antenna	Schwarzbeck	BBHA9120D	9120D-619	2016.04.20	2017.04.19
Broad-Band Horn Antenna	Schwarzbeck	BBHA9170	9170-347	2016.04.20	2017.04.19
Temperature/ Humidity Meter	Zhicheng	ZC1-11	CEP-TH-002	2016.03.31	2017.03.30
EZ-EMC	Fala	Ver CT3A1	N/A	N/A	N/A



5.6 Test Result and Data

The worst case of Radiated Emission below 1GHz:

Engineer :Ternence	Site : EMC Lab AC 102
Limit : FCC_CLASS_B_03M_QP	Margin : 6
EUT : 001	Probe : VERTICAL/ HORIZONTAL
Power : AC 120V/60Hz	Note : Normal Link

No.	Frequency (MHz)	Factor (dB/m)	Reading (dBuV)	Level (dBuV/m)	Limit (dBuV/m)	Margin (dB)	Det.	AntPol. H/V
1	254.0699	-10.67	40.31	29.64	46.00	-16.36	QP	H
2	322.9399	-6.29	37.79	31.50	46.00	-14.50	QP	H
3	432.5500	-4.61	45.94	41.33	46.00	-4.67	QP	H
4	768.1698	0.93	35.01	35.94	46.00	-10.06	QP	H
5	792.4198	0.74	35.67	36.41	46.00	-9.59	QP	H
6	828.3099	1.17	37.59	38.76	46.00	-7.24	QP	H

Note:

1. All Readings below 1GHz are Quasi-Peak, above are performed with peak and/or AVG measurements as necessary.
2. Measurement Level = Reading Level + Correct Factor

No.	Frequency (MHz)	Factor (dB/m)	Reading (dBuV)	Level (dBuV/m)	Limit (dBuV/m)	Margin (dB)	Det.	AntPol. H/V
1	40.6699	-6.57	37.08	30.51	40.00	-9.49	QP	V
2	169.6799	-7.57	34.50	26.93	43.50	-16.57	QP	V
3	363.6800	-6.88	33.76	26.88	46.00	-19.12	QP	V
4	432.5500	-4.61	44.41	39.80	46.00	-6.20	QP	V
5	576.1100	-2.73	28.86	26.13	46.00	-19.87	QP	V
6	831.2199	1.24	34.71	35.95	46.00	-10.05	QP	V

Note:

1. All Readings below 1GHz are Quasi-Peak, above are performed with peak and/or AVG measurements as necessary.
2. Measurement Level = Reading Level + Correct Factor



Above 1G:

Engineer : Ternence	Site : EMC Lab AC 102
Limit : FCC_15_03M_PK	Margin : 6
EUT : 001	Probe : VERTICAL/ HORIZONTAL
Power : AC 120V/60Hz	Note : Transmit 802.11b at 2412MHz

No.	Frequency (MHz)	Factor (dB/m)	Reading (dBuV)	Level (dBuV/m)	Limit (dBuV/m)	Margin (dB)	Det.	AntPol. H/V
1	4824.00	-3.88	49.18	45.30	74.00	-28.70	peak	H
2	7236.00	0.61	44.14	44.75	74.00	-29.25	peak	H
3	4824.00	-3.88	45.87	41.99	74.00	-32.01	peak	V
4	7236.00	0.61	45.10	45.71	74.00	-28.29	peak	V

Note:

1. All Readings below 1GHz are Quasi-Peak, above are performed with peak and/or AVG measurements as necessary.
2. Measurement Level = Reading Level + Correct Factor

Engineer : Ternence	Site : EMC Lab AC 102
Limit : FCC_15_03M_PK	Margin : 6
EUT : 001	Probe : VERTICAL/ HORIZONTAL
Power : AC 120V/60Hz	Note : Transmit 802.11b at 2437MHz

No.	Frequency (MHz)	Factor (dB/m)	Reading (dBuV)	Level (dBuV/m)	Limit (dBuV/m)	Margin (dB)	Det.	AntPol. H/V
1	4874.00	-3.85	45.99	42.14	74.00	-31.86	peak	H
2	7311.00	0.79	43.93	44.72	74.00	-29.28	peak	H
3	4874.00	-3.85	45.57	41.72	74.00	-32.28	peak	V
4	7311.00	0.79	44.79	45.58	74.00	-28.42	peak	V

Note:

1. All Readings below 1GHz are Quasi-Peak, above are performed with peak and/or AVG measurements as necessary.
2. Measurement Level = Reading Level + Correct Factor



Engineer : Ternence	Site : EMC Lab AC 102
Limit : FCC_15_03M_PK	Margin : 6
EUT : 001	Probe : VERTICAL/ HORIZONTAL
Power : AC 120V/60Hz	Note : Transmit 802.11b at 2462MHz

No.	Frequency (MHz)	Factor (dB/m)	Reading (dBuV)	Level (dBuV/m)	Limit (dBuV/m)	Margin (dB)	Det.	AntPol. H/V
1	4924.00	-3.82	45.43	41.61	74.00	-32.39	peak	H
2	7386.00	0.97	45.46	46.43	74.00	-27.57	peak	H
3	4924.00	-3.82	46.08	42.26	74.00	-31.74	peak	V
4	7386.00	0.97	46.15	47.12	74.00	-26.88	peak	V

Note:

1. All Readings below 1GHz are Quasi-Peak, above are performed with peak and/or AVG measurements as necessary.
2. Measurement Level = Reading Level + Correct Factor

Engineer : Ternence	Site : EMC Lab AC 102
Limit : FCC_15_03M_PK	Margin : 6
EUT : 001	Probe : VERTICAL/ HORIZONTAL
Power : AC 120V/60Hz	Note : Transmit 802.11g at 2412MHz

No.	Frequency (MHz)	Factor (dB/m)	Reading (dBuV)	Level (dBuV/m)	Limit (dBuV/m)	Margin (dB)	Det.	AntPol. H/V
1	4824.00	-3.88	45.37	41.49	74.00	-32.51	peak	H
2	7236.00	0.61	45.93	46.54	74.00	-27.46	peak	H
3	4824.00	-3.88	45.51	41.63	74.00	-32.37	peak	V
4	7236.00	0.61	45.27	45.88	74.00	-28.12	peak	V

Note:

1. All Readings below 1GHz are Quasi-Peak, above are performed with peak and/or AVG measurements as necessary.
2. Measurement Level = Reading Level + Correct Factor



Engineer : Ternence	Site : EMC Lab AC 102
Limit : FCC_15_03M_PK	Margin : 6
EUT : 001	Probe : VERTICAL/ HORIZONTAL
Power : AC 120V/60Hz	Note : Transmit 802.11g at 2437MHz

No.	Frequency (MHz)	Factor (dB/m)	Reading (dBuV)	Level (dBuV/m)	Limit (dBuV/m)	Margin (dB)	Det.	AntPol. H/V
1	4874.00	-3.85	45.56	41.71	74.00	-32.29	peak	H
2	7311.00	0.79	44.97	45.76	74.00	-28.24	peak	H
3	4874.00	-3.85	45.14	41.29	74.00	-32.71	peak	V
4	7311.00	0.79	44.64	45.43	74.00	-28.57	peak	V

Note:

1. All Readings below 1GHz are Quasi-Peak, above are performed with peak and/or AVG measurements as necessary.
2. Measurement Level = Reading Level + Correct Factor

Engineer : Ternence	Site : EMC Lab AC 102
Limit : FCC_15_03M_PK	Margin : 6
EUT : 001	Probe : VERTICAL/ HORIZONTAL
Power : AC 120V/60Hz	Note : Transmit 802.11g at 2462MHz

No.	Frequency (MHz)	Factor (dB/m)	Reading (dBuV)	Level (dBuV/m)	Limit (dBuV/m)	Margin (dB)	Det.	AntPol. H/V
1	4924.00	-3.82	45.11	41.29	74.00	-32.71	peak	H
2	7386.00	0.97	45.26	46.23	74.00	-27.77	peak	H
3	4924.00	-3.82	45.38	41.56	74.00	-32.44	peak	V
4	7386.00	0.97	44.73	45.70	74.00	-28.30	peak	V

Note:

1. All Readings below 1GHz are Quasi-Peak, above are performed with peak and/or AVG measurements as necessary.
2. Measurement Level = Reading Level + Correct Factor



Engineer : Ternence	Site : EMC Lab AC 102
Limit : FCC_15_03M_PK	Margin : 6
EUT : 001	Probe : VERTICAL/ HORIZONTAL
Power : AC 120V/60Hz	Note : Transmit 802.11n(20MHz) at 2412MHz

No.	Frequency (MHz)	Factor (dB/m)	Reading (dBuV)	Level (dBuV/m)	Limit (dBuV/m)	Margin (dB)	Det.	AntPol. H/V
1	4824.00	-3.88	49.29	45.41	74.00	-28.59	peak	H
2	7236.00	0.61	44.38	44.99	74.00	-29.01	peak	H
3	4824.00	-3.88	46.61	42.73	74.00	-31.27	peak	V
4	7236.00	0.61	44.74	45.35	74.00	-28.65	peak	V

Note:

- All Readings below 1GHz are Quasi-Peak, above are performed with peak and/or AVG measurements as necessary.
- Measurement Level = Reading Level + Correct Factor

Engineer : Ternence	Site : EMC Lab AC 102
Limit : FCC_15_03M_PK	Margin : 6
EUT : 001	Probe : VERTICAL/ HORIZONTAL
Power : AC 120V/60Hz	Note : Transmit 802.11n(20MHz) at 2437MHz

No.	Frequency (MHz)	Factor (dB/m)	Reading (dBuV)	Level (dBuV/m)	Limit (dBuV/m)	Margin (dB)	Det.	AntPol. H/V
1	4874.00	-3.85	46.62	42.77	74.00	-31.23	peak	H
2	7311.00	0.79	47.36	48.15	74.00	-25.85	peak	H
3	4874.00	-3.85	45.69	41.84	74.00	-32.16	peak	V
4	7311.00	0.79	44.79	45.58	74.00	-28.42	peak	V

Note:

- All Readings below 1GHz are Quasi-Peak, above are performed with peak and/or AVG measurements as necessary.
- Measurement Level = Reading Level + Correct Factor



Engineer : Ternence	Site : EMC Lab AC 102
Limit : FCC_15_03M_PK	Margin : 6
EUT : 001	Probe : VERTICAL/ HORIZONTAL
Power : AC 120V/60Hz	Note : Transmit 802.11n(20MHz) at 2462MHz

No.	Frequency (MHz)	Factor (dB/m)	Reading (dBuV)	Level (dBuV/m)	Limit (dBuV/m)	Margin (dB)	Det.	AntPol. H/V
1	4924.00	-3.82	46.13	42.31	74.00	-31.69	peak	H
2	7386.00	0.97	45.52	46.49	74.00	-27.51	peak	H
3	4924.00	-3.82	45.53	41.71	74.00	-32.29	peak	V
4	7386.00	0.97	45.86	46.83	74.00	-27.17	peak	V

Note:

1. All Readings below 1GHz are Quasi-Peak, above are performed with peak and/or AVG measurements as necessary.
2. Measurement Level = Reading Level + Correct Factor



The worst case of Radiated Emission 1~18GHz:

Site: AC102	Time: 2016/08/21
Limit: FCC_Part15.209_RE(3m)	Margin: 0
Probe: N/A	Polarity: Horizontal
EUT: 001	Power: AC 120V/60Hz
Note: Mode:Transmit 802.11n(20MHz) at 2437MHz	

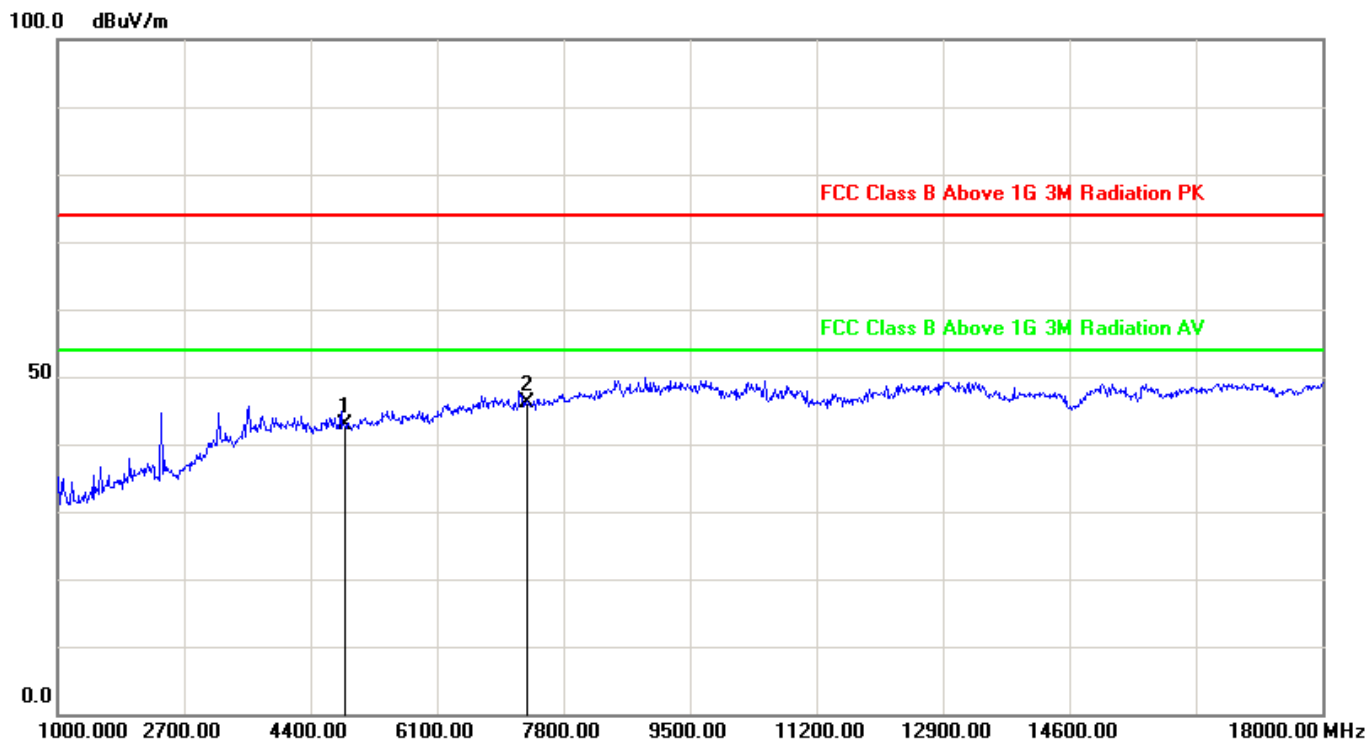

No.	Frequency (MHz)	Factor (dB/m)	Reading (dBuV)	Level (dBuV/m)	Limit (dBuV/m)	Margin (dB)	Det.
1	4874.000	-3.85	46.62	42.77	74.00	-31.23	peak
2	7311.000	0.79	47.36	48.15	74.00	-25.85	peak

Note:

1. All Readings below 1GHz are Quasi-Peak, above are performed with peak and/or AVG measurements as necessary.
2. Measurement Level = Reading Level + Correct Factor



Site: AC102	Time: 2016/06/16
Limit: FCC_Part15.209_RE(3m)	Margin: 0
Probe: N/A	Polarity: Vertical
EUT: 001	Power: AC 120V/60Hz
Note: Mode: Transmit 802.11n(20MHz) at 2437MHz	

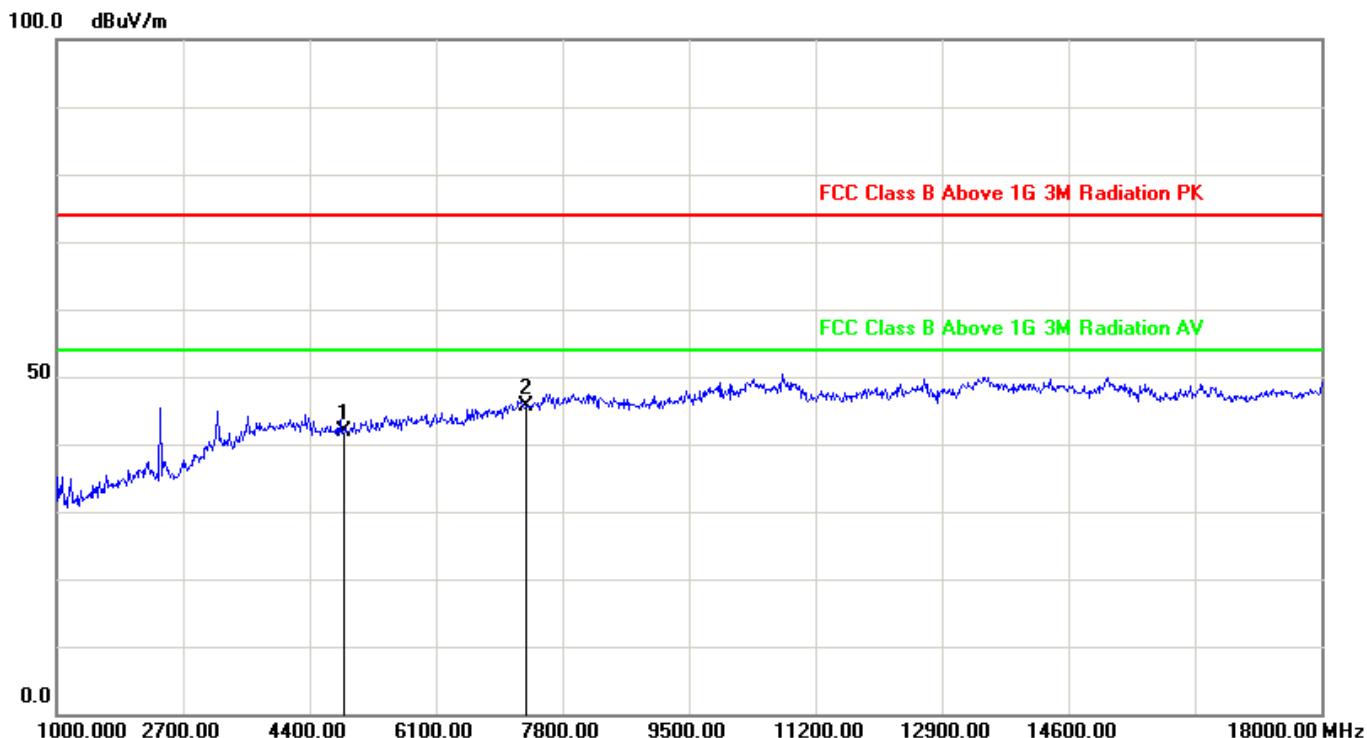

No.	Frequency (MHz)	Factor (dB/m)	Reading (dBuV)	Level (dBuV/m)	Limit (dBuV/m)	Margin (dB)	Det.
1	4874.000	-3.85	45.69	41.84	74.00	-32.16	peak
2	7311.000	0.79	44.79	45.58	74.00	-28.42	peak

Note:

1. All Readings below 1GHz are Quasi-Peak, above are performed with peak and/or AVG measurements as necessary.
2. Measurement Level = Reading Level + Correct Factor
3. The test trace is same as the ambient noise (the test frequency range: 9kHz~30MHz, 18GHz~40GHz), therefore no data appear in the report.



6. Maximum Output Power

6.1 Test Limit

The maximum power shall be less 1Watt (30dBm).

The conducted output power limits specified in §15.247(b) are based on the use of transmit antennae with directional gains that do not exceed 6 dBi. If transmit antennae with an effective directional gain greater than 6 dBi are used, then the conducted output power from the EUT shall be reduced as specified in §15.247(b) and (c).

Per RSS247 Issue 1 Section 5.4(4), for DTSs employing digital modulation techniques operating in the bands 902-928 MHz and 2400-2483.5 MHz, the maximum conducted output power shall not exceed 1W.

6.2 Test Procedure

The EUT was tested according to DTS test procedure of KDB 558074 for compliance to FCC 47CFR 15.247 requirements. The maximum conducted AVG output power using KDB 558074 D01v03r05 - Section 9.2.3.2 AVGPm-G Average Power Method.

The Maximum peak conducted output power using KDB 558074 D01v03r05 - Section 9.1.1 RBW ≥ DTS bandwidth Method.

6.3 Test Setup Layout

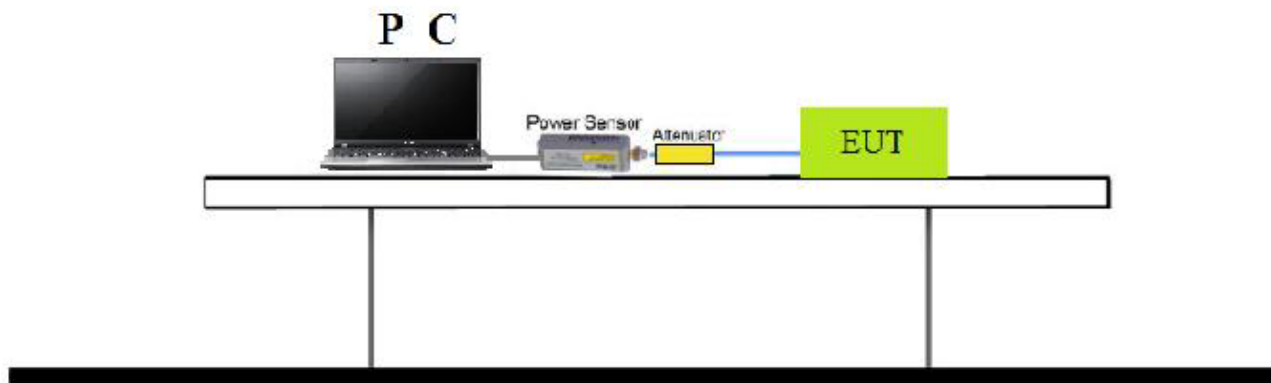

6.4 Measurement Equipment

Instrument	Manufacturer	Type No.	Serial No.	Calibration Date	Valid Date.
PC	Lenovo	E40-70	MP078UQV	N/A	N/A
POWER SENSOR	Agilent	U2021XA	MY53260020	2016/03/27	2017/03/26
Series Power Meter	ANRITSU	ML2495A	1224005	2016/03/27	2017/03/26
Temperature/Humidity Meter	Zhicheng	ZC1-11	CEP-TH-003	2016/03/31	2017/03/30



6.5 Test Result and Data

Power output test was verified over all data rates of each mode shown as below, and then choose the maximum power output (blue marker) for final test of each channel.

MCS Index for 802.11n	Spatial Streams	Data Rate(Mbps)					
		802.11b	802.11g	20MHz Bandwidth		40MHz Bandwidth	
				800ns GI	400ns GI	800ns GI	400ns GI
0	1	1	6	6.5	7.2	13.5	15.0
1	1	2	9	13.0	14.4	27.0	30.0
2	1	5.5	12	19.5	21.7	40.5	45.0
3	1	11	18	26.0	28.9	54.0	60.0
4	1	--	24	39.0	43.3	81.0	90.0
5	1	--	36	52.0	57.8	108.0	120.0
6	1	--	48	58.5	65.0	121.5	135.0
7	1	--	54	65.0	72.2	135.0	150.0
8	2	--	--	13.0	14.4	27.0	30.0
9	2	--	--	26.0	28.9	54.0	60.0
10	2	--	--	39.0	43.3	81.0	90.0
11	2	--	--	52.0	57.8	108.0	120.0
12	2	--	--	78.0	86.7	162.0	180.0
13	2	--	--	104.0	115.6	216.0	240.0
14	2	--	--	117.0	130.0	243.0	270.0
15	2	--	--	130.0	144.0	270.0	300.0



Test Item	Maximum Output Power
Test Mode	Transmit by 802.11b
Test Date	2016-08-20

Channel No.	Frequency (MHz)	Average Power (dBm)	Peak Power (dBm)	Required Limit (dBm)	Result
01	2412	13.91	16.97	30	Pass
06	2437	13.65	16.62	30	Pass
11	2462	13.55	16.56	30	Pass

Test Item	Maximum Output Power
Test Mode	Transmit by 802.11g
Test Date	2016-08-20

Channel No.	Frequency (MHz)	Average Power (dBm)	Peak Power (dBm)	Required Limit (dBm)	Result
01	2412	9.74	21.65	30	Pass
06	2437	9.57	21.37	30	Pass
11	2462	9.41	21.34	30	Pass

Test Item	Maximum Output Power
Test Mode	Transmit by 802.11n (20MHz)
Test Date	2016-08-20

Channel No.	Frequency (MHz)	Average Power (dBm)	Peak Power (dBm)	Required Limit (dBm)	Result
01	2412	8.57	20.71	30	Pass
06	2437	8.49	20.70	30	Pass
11	2462	8.35	20.58	30	Pass



7. Occupied Bandwidth

7.1 Test Limit

Systems using digital modulation techniques may operate in the 902 - 928 MHz, 2400 - 2483.5 MHz, and 5725- 5850 MHz band. The minimum 6 dB bandwidth shall be at least 500 kHz.

7.2 Test Procedures

According to KDB 558074 D01v03r05 - Section 8.1.

- a. The transmitter output was connected to the spectrum analyzer.
- b. Set RBW of spectrum analyzer to 100KHz and VBW \geq 3x RBW.
- c. The 6 dB bandwidth is defined as the total spectrum the power of which is higher than peak power minus 6 dB.
- d. The 6dB Bandwidth was measured and recorded.

7.3 Test Setup Layout

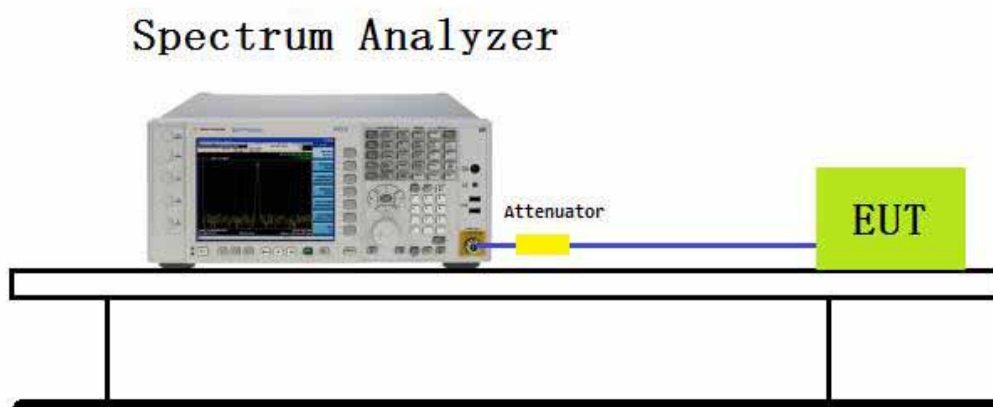

7.4 Measurement Equipment

Instrument/Ancillary	Model No.	Manufacturer	Serial No.	Calibration Date	Valid Date
Spectrum Analyzer	N9010A	Agilent	MY53400169	2015.11.11	2016.11.11



7.5 Test Result and Data

Test Item	Occupied Bandwidth
Test Mode	Transmit by 802.11b
Test Date	2016-08-20

Channel No.	Frequency (MHz)	Measurement Level (MHz)	99% Occupied Bandwidth (MHz)	Result
01	2412	9.326	13.884	Pass
06	2437	9.057	13.909	Pass
11	2462	9.565	13.914	Pass

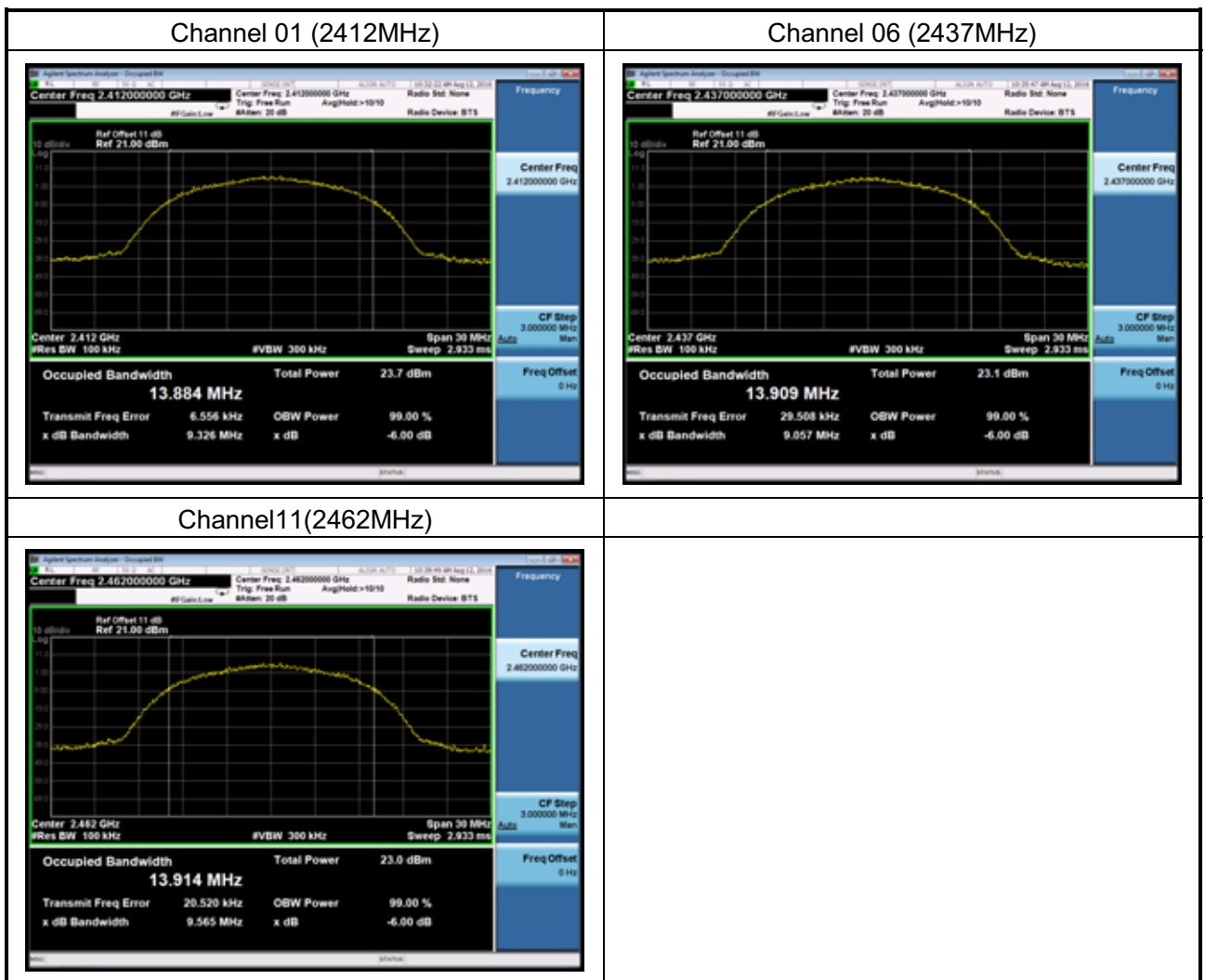



Test Item	Occupied Bandwidth
Test Mode	Transmit by 802.11g
Test Date	2016-08-20

Channel No.	Frequency (MHz)	Measurement Level (MHz)	99% Occupied Bandwidth (MHz)	Result
01	2412	15.70	16.294	Pass
06	2437	15.99	16.291	Pass
11	2462	15.43	16.285	Pass

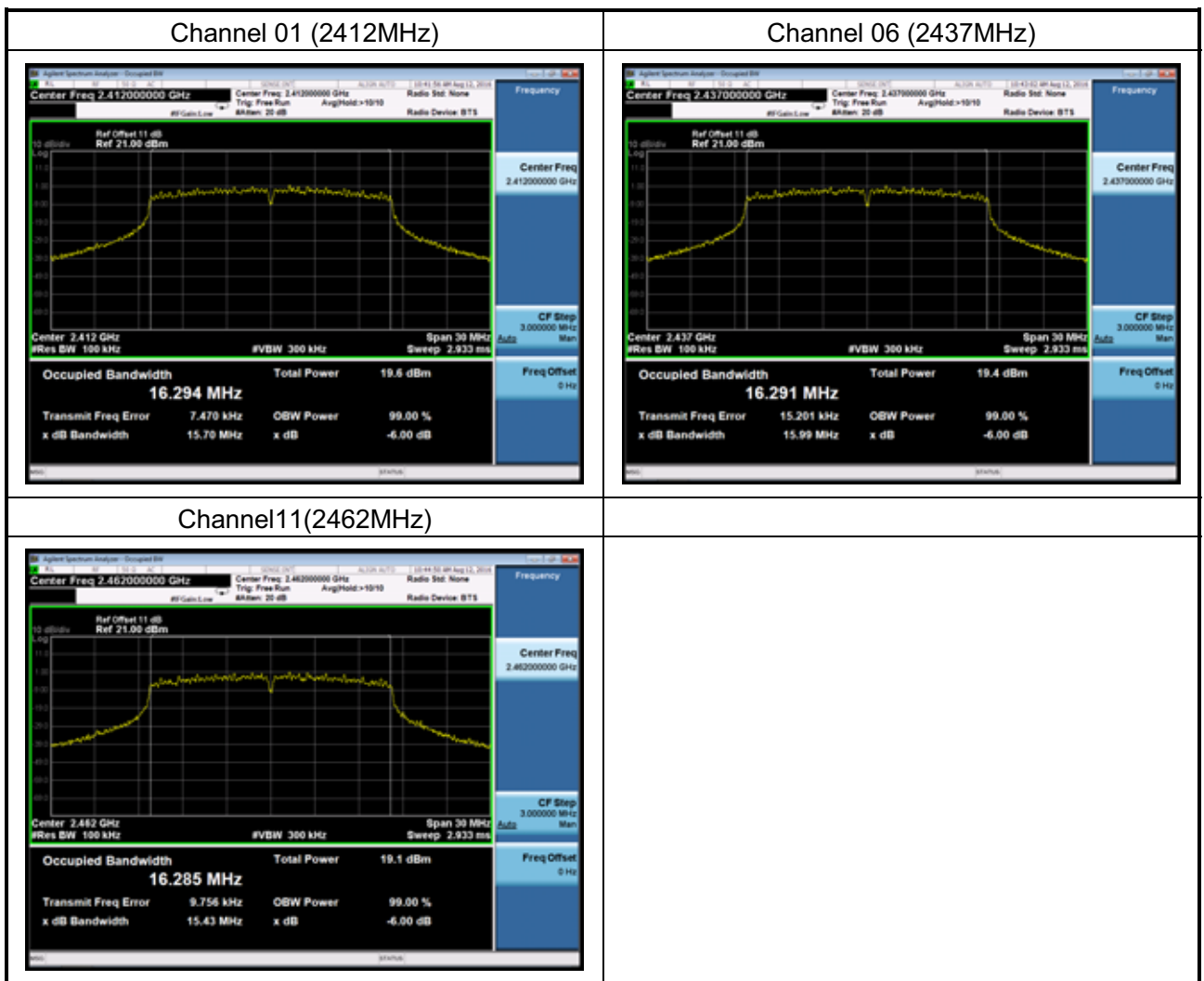



Test Item	Occupied Bandwidth
Test Mode	Transmit by 802.11n (20MHz)
Test Date	2016-08-20

Channel No.	Frequency (MHz)	Measurement Level (MHz)	99% Occupied Bandwidth (MHz)	Result
01	2412	15.42	17.479	Pass
06	2437	15.43	17.456	Pass
11	2462	16.01	17.465	Pass

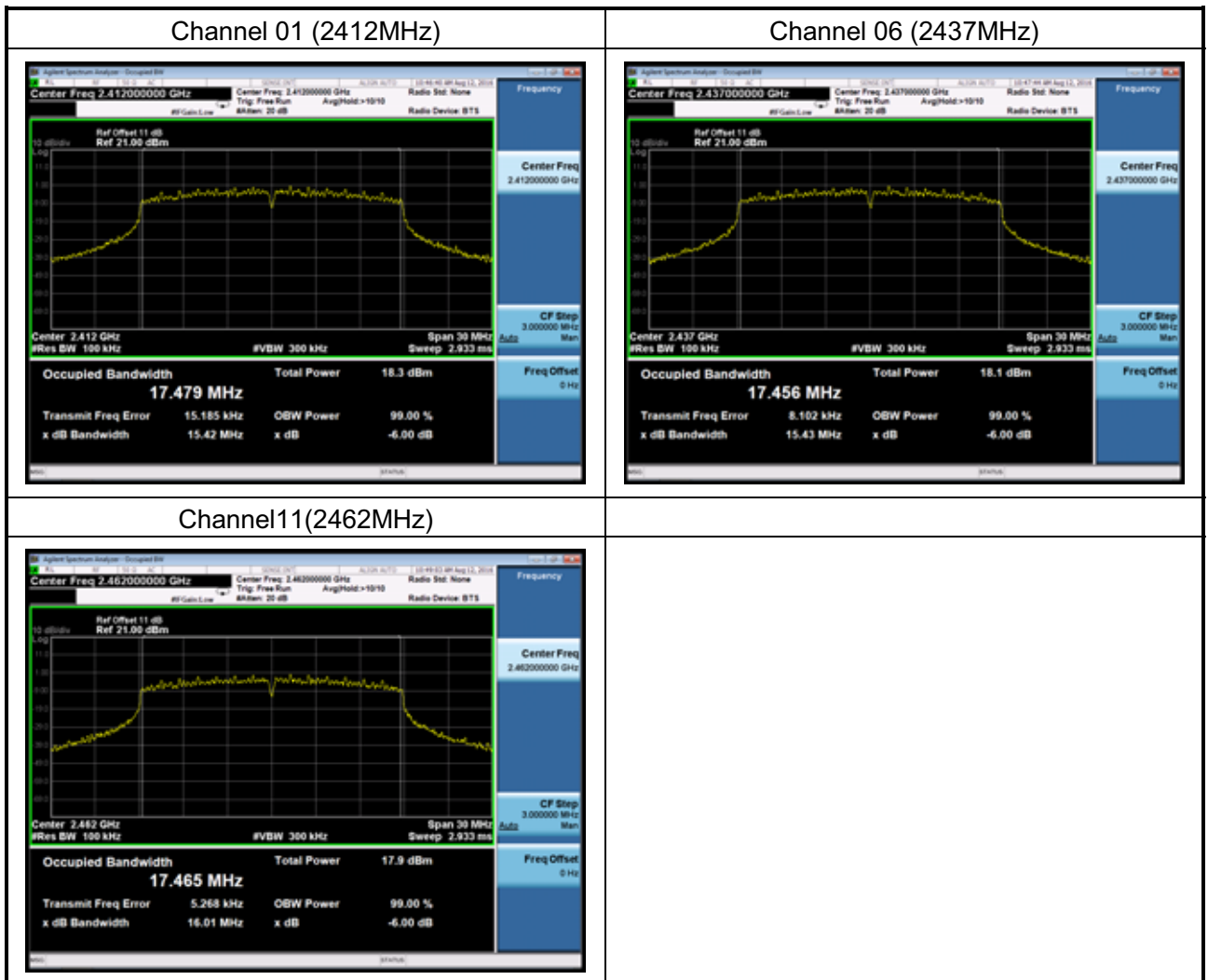



8. Power Spectral Density

8.1 Test Limit

The Maximum of Power Spectral Density Measurement is 8dBm.

8.2 Test Procedure

The EUT was setup according to ANSI C63.10, 2013; tested according to DTS test procedure of KDB 558074 for compliance to FCC 47CFR 15.247 requirements.

The maximum power spectral density using KDB 558074 section 10.2 PKPSD (peak PSD) method.

- a) Set analyzer center frequency to DTS channel center frequency.
- b) Set the span to 1.5 times the DTS bandwidth.
- c) Set the RBW to: $3 \text{ kHz} \leq \text{RBW} \leq 100 \text{ kHz}$. (Actually we use 3kHz RBW)
- d) Set the VBW $\geq 3 \times \text{RBW}$.
- e) Detector = peak.
- f) Sweep time = auto couple.
- g) Trace mode = max hold.
- h) Allow trace to fully stabilize.
- i) Use the peak marker function to determine the maximum amplitude level within the band.
- j) If measured value exceeds limit, reduce RBW (no less than 3 kHz) and repeat.

8.3 Test Setup Layout

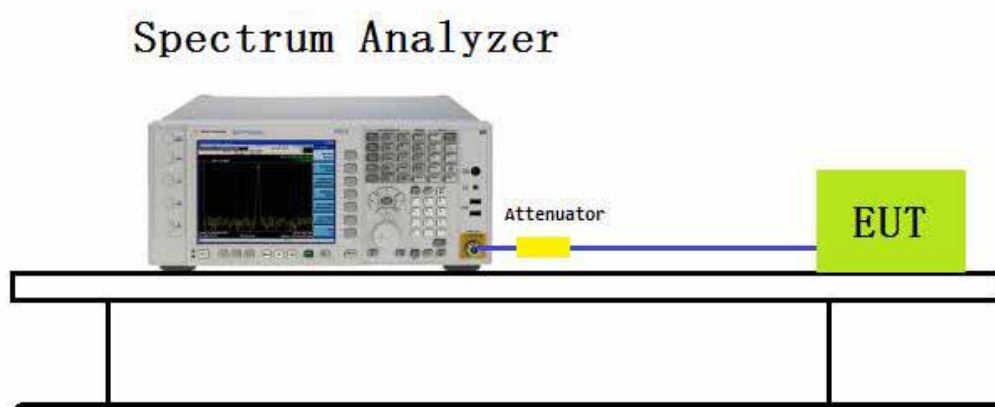

8.4 Measurement Equipment

Instrument/Ancillary	Model No.	Manufacturer	Serial No.	Calibration Date	Valid Date
Spectrum Analyzer	N9010A	Agilent	MY53400169	2015.11.11	2016.11.11



8.5 Test Result and Data

Test Item	Power Spectral Density
Test Mode	Transmit by 802.11b
Test Date	2016-08-20

Channel	Frequency (MHz)	Power Spectral Density (dBm/3kHz)	Limit (dBm/3kHz)	Result
01	2412	-8.995	8	Pass
06	2437	-7.266	8	Pass
11	2462	-9.613	8	Pass

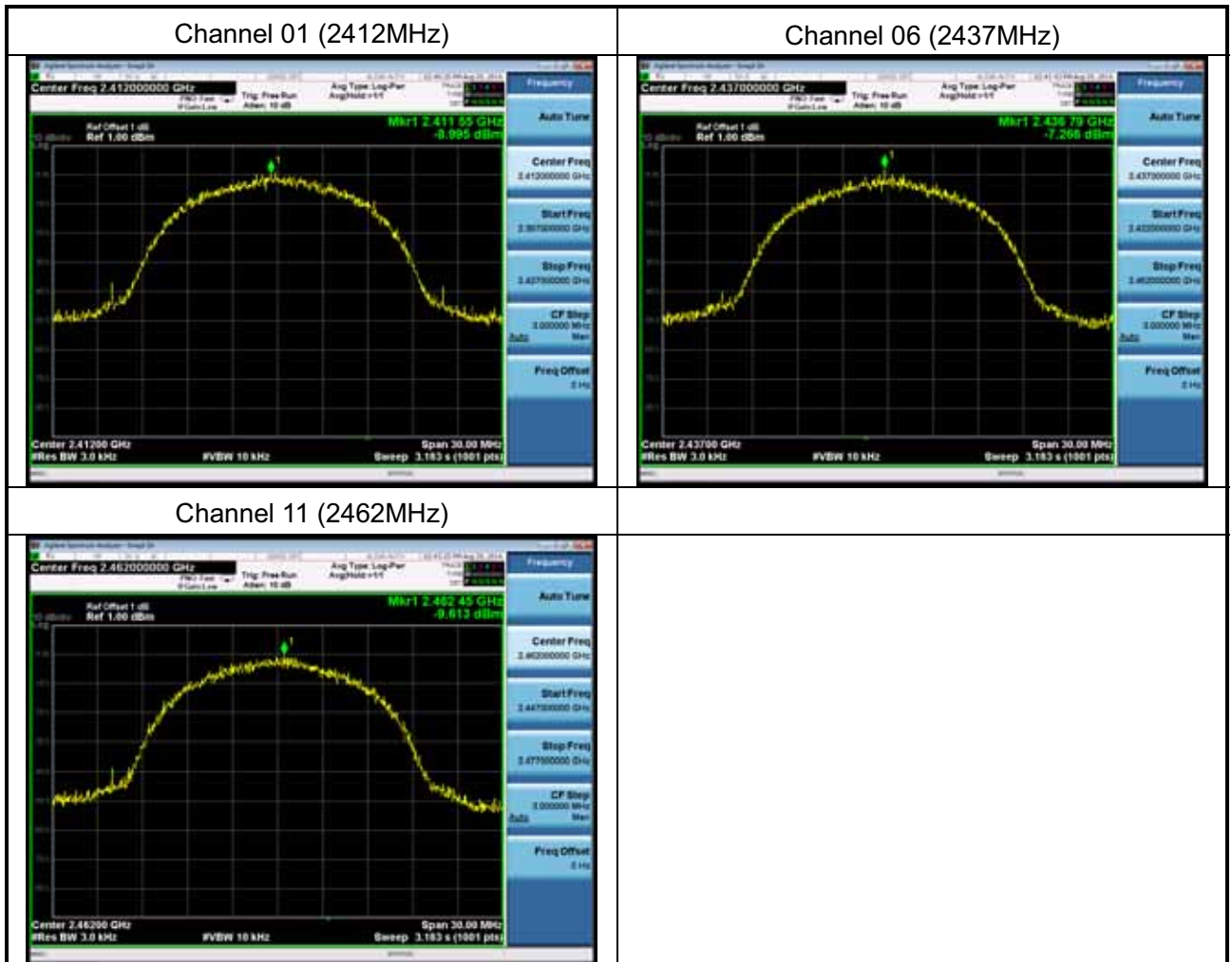



Test Item	Power Spectral Density
Test Mode	Transmit by 802.11g
Test Date	2016-08-20

Channel	Frequency (MHz)	Power Spectral Density (dBm/3kHz)	Limit (dBm/3kHz)	Result
01	2412	-14.173	8	Pass
06	2437	-14.339	8	Pass
11	2462	-14.554	8	Pass

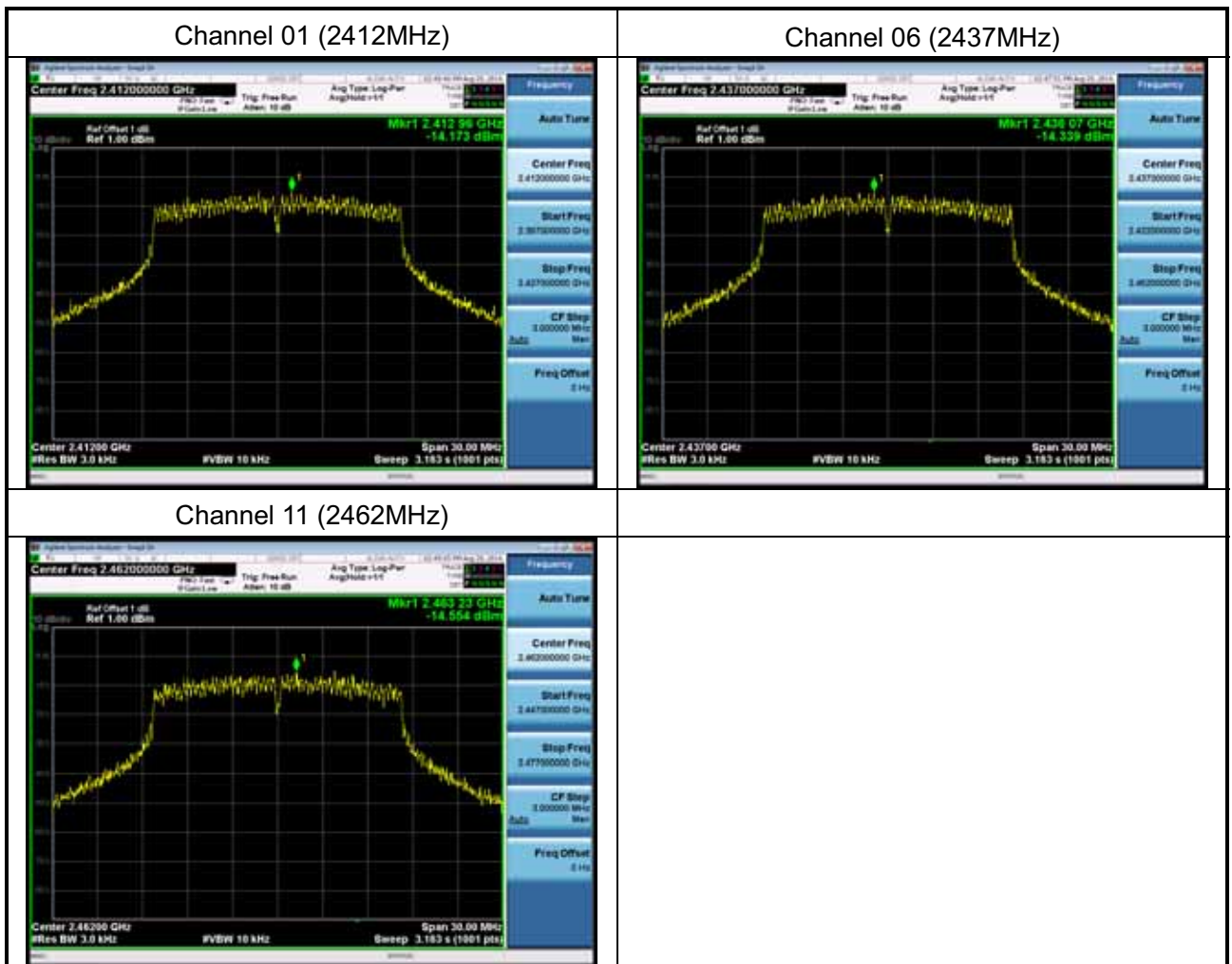



Test Item	Power Spectral Density
Test Mode	Transmit by 802.11n (20MHz)
Test Date	2016-08-20

Channel	Frequency (MHz)	Power Spectral Density (dBm/3kHz)	Limit (dBm/3kHz)	Result
01	2412	-13.353	8	Pass
06	2437	-15.107	8	Pass
11	2462	-14.479	8	Pass

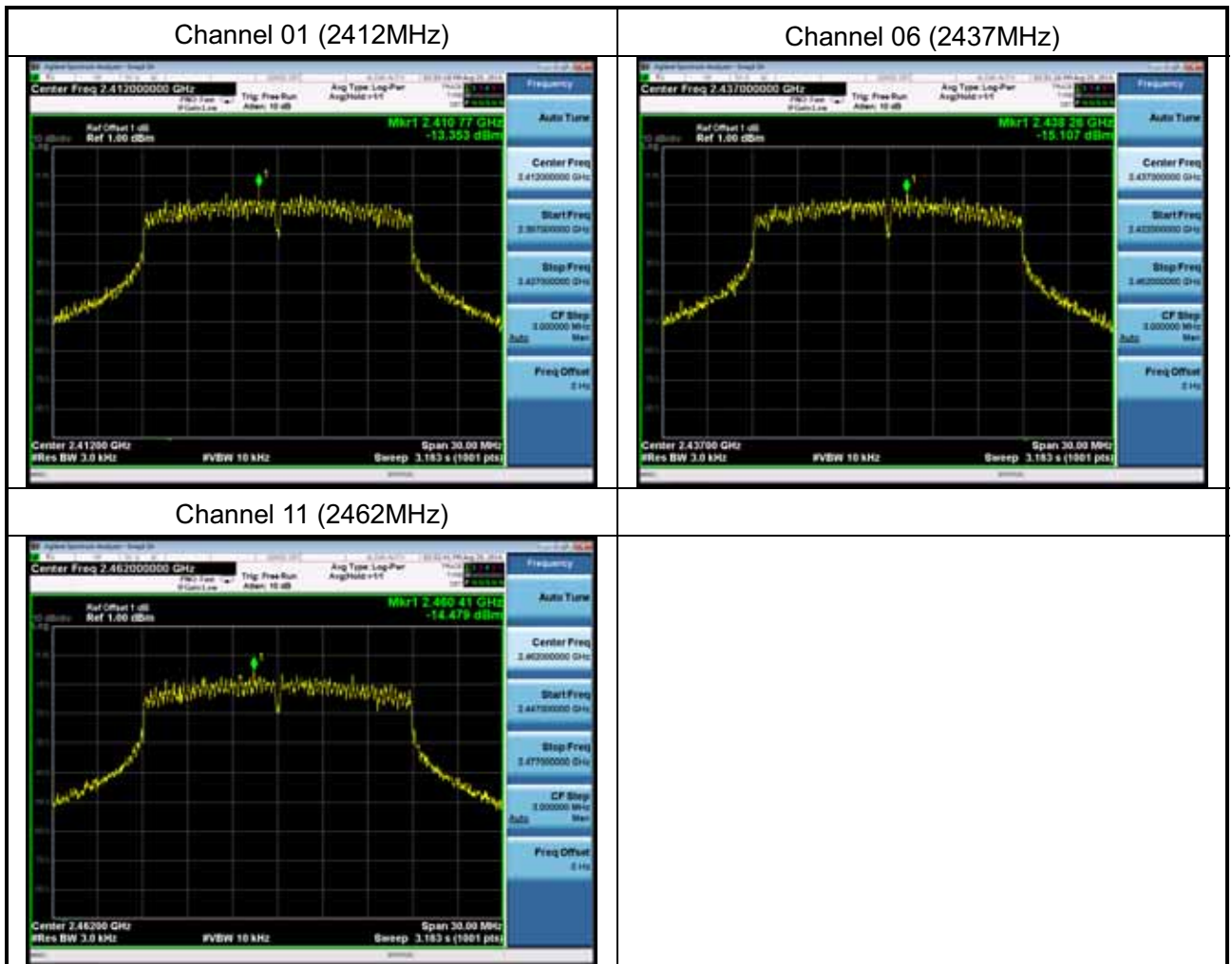



9. Band Edges Measurement

9.1 Test Limit

1. If the maximum peak conducted output power procedure was used to determine compliance as described in 11.9.1, then the peak output power measured in any 100 kHz bandwidth outside of the authorized frequency band shall be attenuated by at least 20 dB relative to the maximum.
2. If maximum conducted (average) output power was used to determine compliance as described in 11.9.2, then the peak power in any 100 kHz bandwidth outside of the authorized frequency band shall be attenuated by at least 30 dB relative to the maximum in-band peak PSD level in 100 kHz (i.e., 30 dBc).

9.2 in-band peak PSD level in 100 kHz (i.e., 20 dBc). Test Procedure

KDB 558074 D01v03r05 – Section 12.2.4 (peak power measurements)

KDB 558074 D01v03r05 – Section 12.2.5 (average power measurements)

9.3 Test Setting

Peak Measurements above 1GHz

1. Analyzer center frequency was set to the frequency of the radiated spurious emission of interest
2. RBW = 1MHz
3. VBW = 3MHz
4. Detector = peak
5. Sweep time = auto couple
6. Trace mode = max hold
7. Trace was allowed to stabilize

Average Measurements above 1GHz

7.8.3. Average Field Strength Measurements

1. Analyzer center frequency was set to the frequency of the radiated spurious emission of interest
2. RBW = 1MHz
3. $VBW \geq 1/T$
4. De As an alternative, the instrument may be set to linear detector mode. Ensure that video filtering is applied in linear voltage domain (rather than in a log or dB domain). Some instruments require linear display mode in order to accomplish this. Others have a setting for Average-VBW Type, which can be set to "Voltage" regardless of the display mode
5. Detector = Peak
6. Sweep time = auto
7. Trace mode = max hold
8. Allow max hold to run for at least 50 times (1/duty cycle) traces



9.4 Test Setup Layout

Radiated

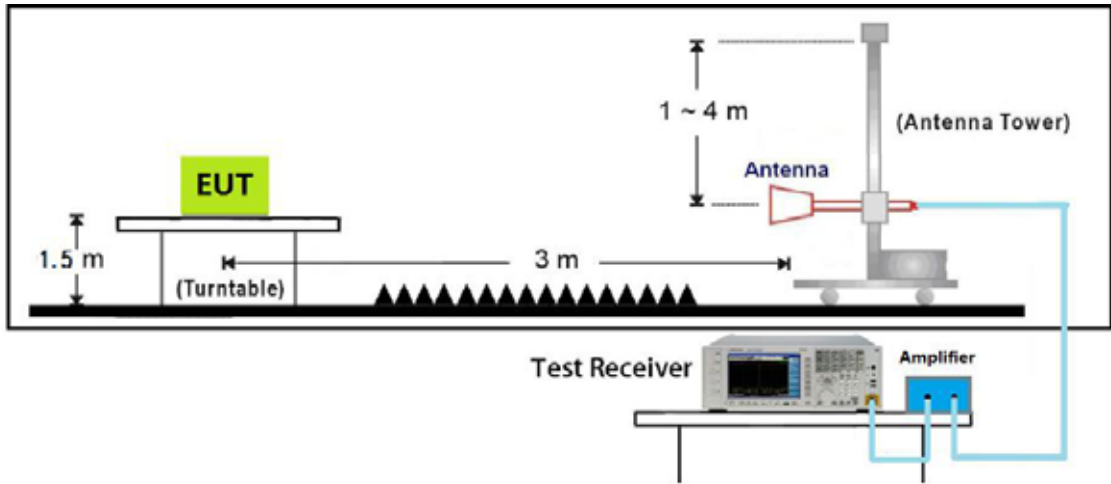

Conducted

Spectrum Analyzer

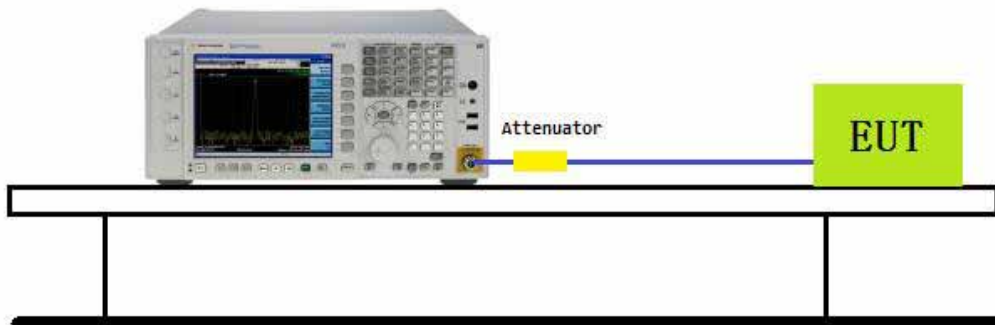

**9.5 Measurement Equipment**

Instrument/Ancillary	Manufacturer	Model No.	Serial No.	Calibration Date	Valid Date.
EMI Test Receiver	R&S	ESCI	101183	2016.03.28	2017.03.29
Spectrum Analyzer	N9010A	Agilent	MY53400169	2015.11.11	2016.11.11
Spectrum Analyzer	R&S	FSP40	100324	2016.03.23	2017.03.24
H64 Preamplifier	HP	8447F	3113A05582	2016.03.24	2017.03.23
Preamplifier	songyi	EM330	60618	2016.03.29	2017.03.28
Preamplifier	Agilent	8449B	3008A02342	2016.03.29	2017.03.28
Preamplifier	COM-POWER	PA-840	711885	2016.03.29	2017.03.28
Bilog Antenna	Sunol Science	JB1	A072414-1	2016.04.22	2017.04.21
Broad-Band Horn Antenna	Schwarzbeck	BBHA9120D	9120D-619	2016.04.20	2017.04.19
Broad-Band Horn Antenna	Schwarzbeck	BBHA9170	9170-347	2016.04.20	2017.04.19
Temperature/ Humidity Meter	Zhicheng	ZC1-11	CEP-TH-002	2016.03.31	2017.03.30



9.6 Test Result and Data

Site: AC102	Time: 2016/08/22 - 10:04
Limit: FCC_Part15.209_RE(3m)	Margin: 0
Probe: N/A	Polarity: Vertical
EUT: 001	Power: AC 120V/60Hz
Note: Mode 1: Transmit 802.11b at 2412MHz	

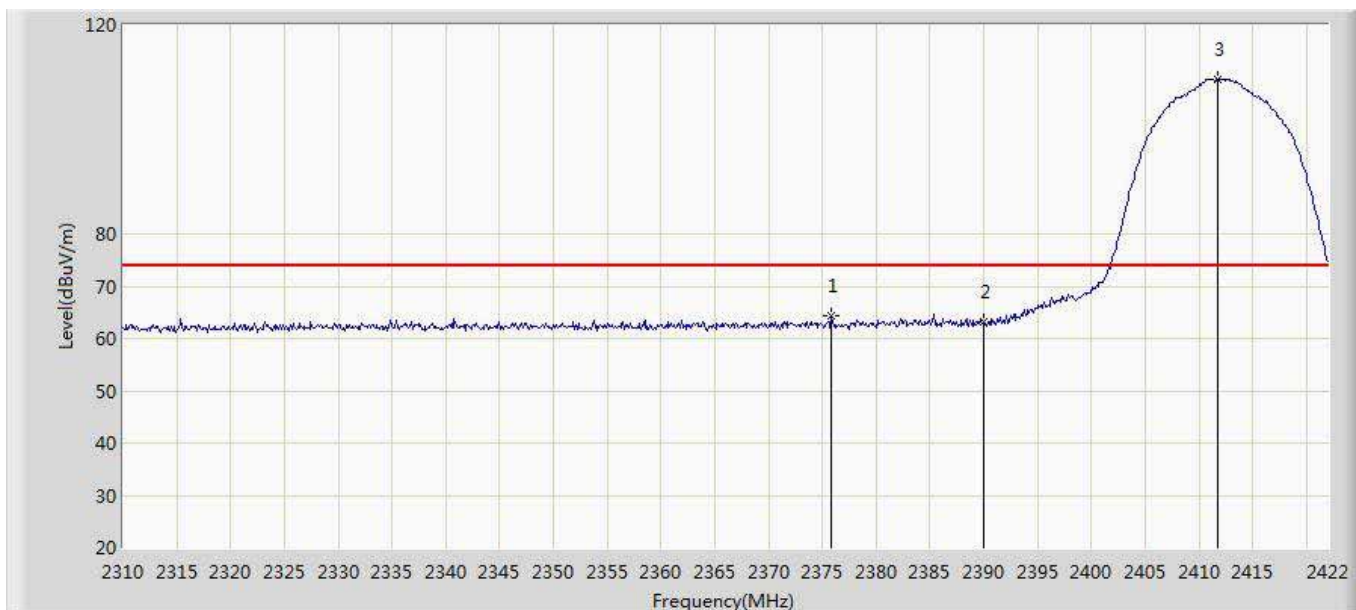

No	Mark	Frequency (MHz)	Measure Level (dBuV/m)	Reading Level (dBuV)	Over Limit (dB)	Limit (dBuV/m)	Factor (dB)	Type
1		2375.856	64.397	31.344	-9.603	74.000	33.053	PK
2		2390.000	63.109	29.998	-10.891	74.000	33.111	PK
3	*	2411.808	109.612	76.412	N/A	N/A	33.200	PK

Note: Measure Level (dBuV/m) = Reading Level (dBuV) + Factor (dB)

Factor (dB) = Cable Loss (dB) + Antenna Factor (dB/m)



Site: AC102	Time: 2016/08/22 - 10:24
Limit: FCC_Part15.209_RE(3m)	Margin: 0
Probe: N/A	Polarity: Vertical
EUT: 001	Power: AC 120V/60Hz
Note: Mode 1: Transmit 802.11b at 2412MHz	

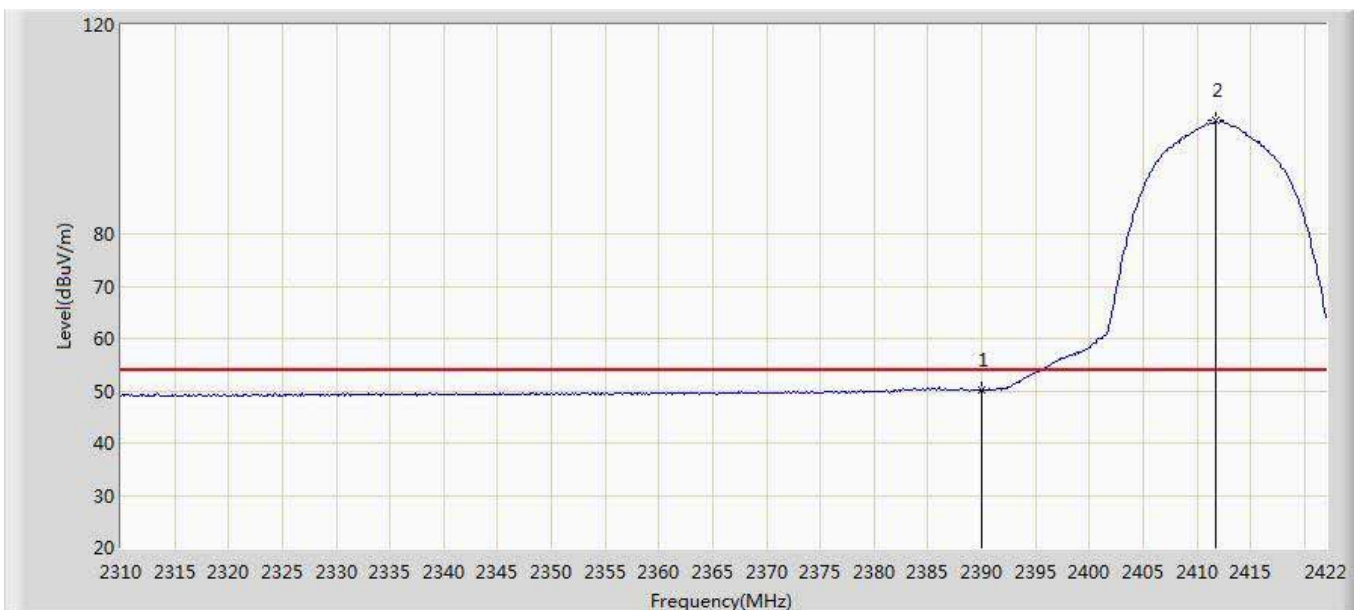

No	Mark	Frequency (MHz)	Measure Level (dBuV/m)	Reading Level (dBuV)	Over Limit (dB)	Limit (dBuV/m)	Factor (dB)	Type
1		2390.000	50.253	17.142	-3.747	54.000	33.111	AV
2	*	2411.808	101.651	68.451	N/A	N/A	33.200	AV

Note: Measure Level (dBμV/m) = Reading Level (dBμV) + Factor (dB)

Factor (dB) = Cable Loss (dB) + Antenna Factor (dB/m)



Site: AC102	Time: 2016/08/22 - 10:25
Limit: FCC_Part15.209_RE(3m)	Margin: 0
Probe: N/A	Polarity: Horizontal
EUT: 001	Power: AC 120V/60Hz
Note: Mode 1: Transmit 802.11b at 2412MHz	

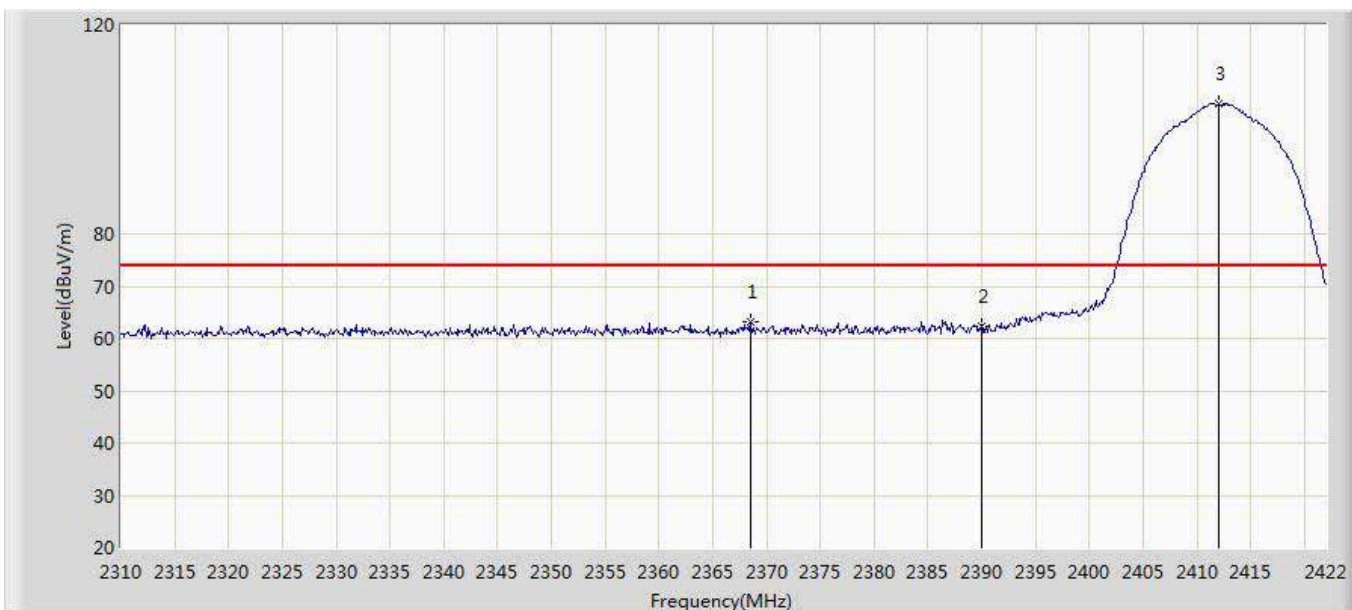

No	Mark	Frequency (MHz)	Measure Level (dBuV/m)	Reading Level (dBuV)	Over Limit (dB)	Limit (dBuV/m)	Factor (dB)	Type
1		2368.464	63.117	30.093	-10.883	74.000	33.024	PK
2		2390.000	62.292	29.181	-11.708	74.000	33.111	PK
3	*	2412.032	104.939	71.738	N/A	N/A	33.201	PK

Note: Measure Level (dBμV/m) = Reading Level (dBμV) + Factor (dB)

Factor (dB) = Cable Loss (dB) + Antenna Factor (dB/m)



Site: AC102	Time: 2016/08/22 - 10:34
Limit: FCC_Part15.209_RE(3m)	Margin: 0
Probe: N/A	Polarity: Horizontal
EUT: 001	Power: AC 120V/60Hz
Note: Mode 1: Transmit 802.11b at 2412MHz	

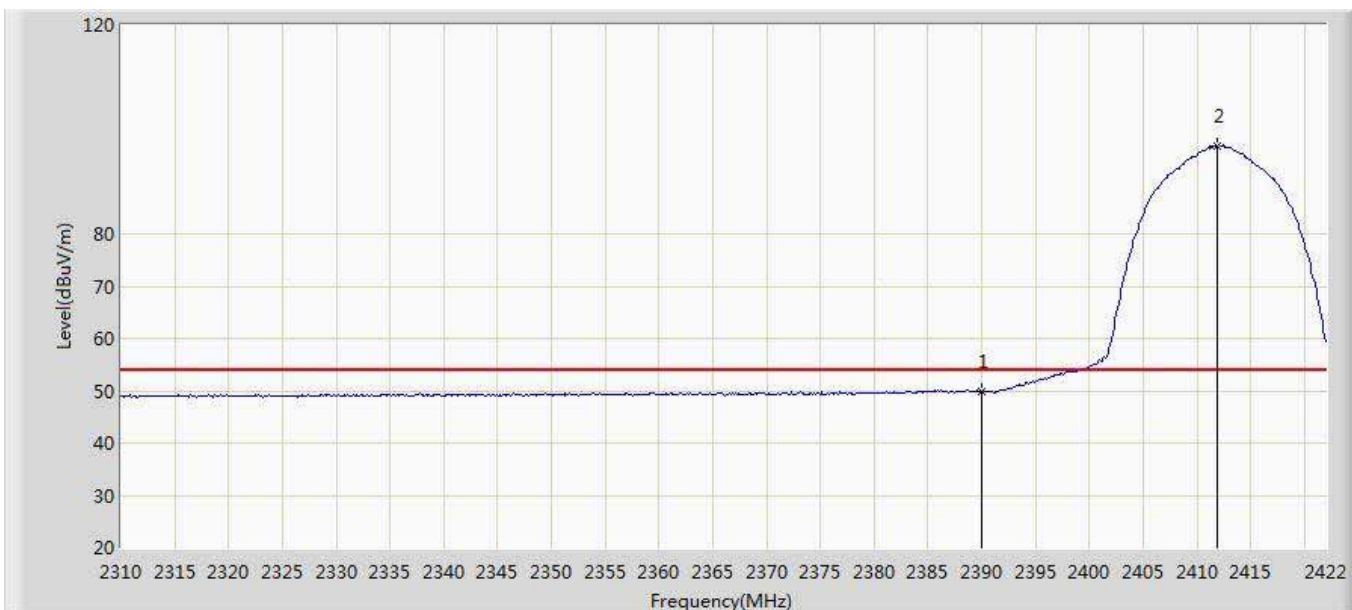

No	Mark	Frequency (MHz)	Measure Level (dBuV/m)	Reading Level (dBuV)	Over Limit (dB)	Limit (dBuV/m)	Factor (dB)	Type
1		2390.000	49.768	16.657	-4.232	54.000	33.111	AV
2	*	2411.920	96.866	63.666	N/A	N/A	33.200	AV

Note: Measure Level (dBμV/m) = Reading Level (dBμV) + Factor (dB)

Factor (dB) = Cable Loss (dB) + Antenna Factor (dB/m)



Site: AC102	Time: 2016/08/22 - 10:36
Limit: FCC_Part15.209_RE(3m)	Margin: 0
Probe: N/A	Polarity: Horizontal
EUT: 001	Power: AC 120V/60Hz
Note: Mode 1: Transmit 802.11b at 2462MHz	

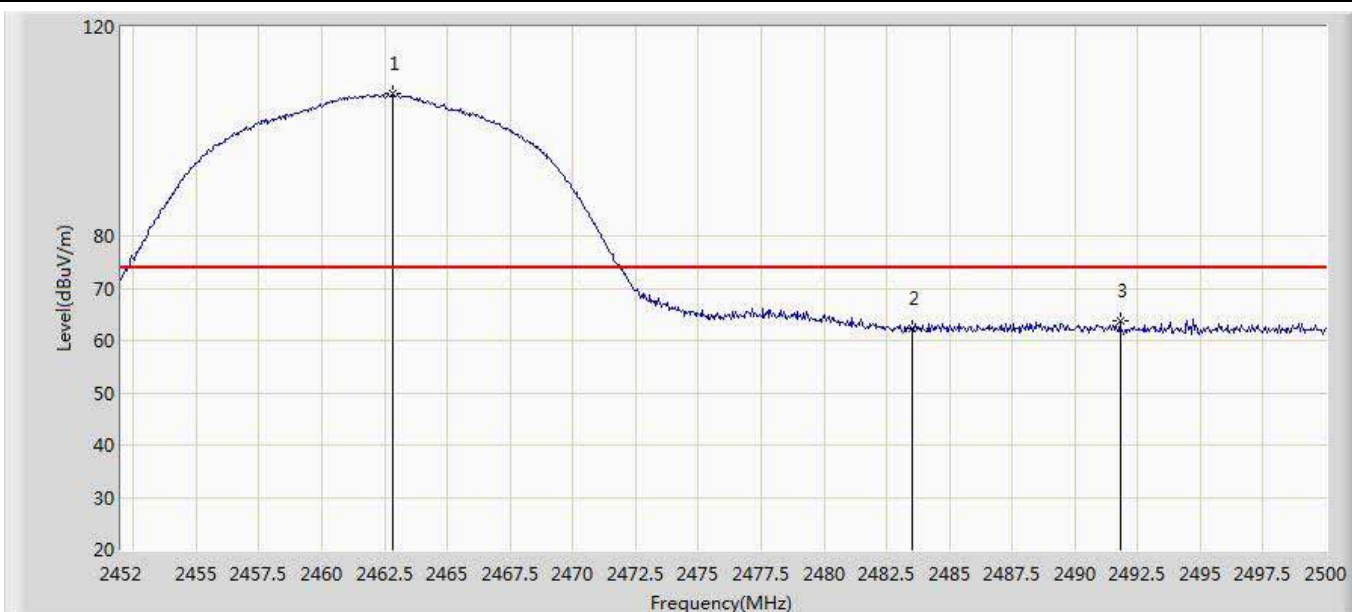

No	Mark	Frequency (MHz)	Measure Level (dBuV/m)	Reading Level (dBuV)	Over Limit (dB)	Limit (dBuV/m)	Factor (dB)	Type
1	*	2462.800	107.114	73.706	N/A	N/A	33.408	PK
2		2483.500	62.200	28.708	-11.800	74.000	33.493	PK
3		2491.792	63.802	30.276	-10.198	74.000	33.526	PK

Note: Measure Level (dBμV/m) = Reading Level (dBμV) + Factor (dB)

Factor (dB) = Cable Loss (dB) + Antenna Factor (dB/m)



Site: AC102	Time: 2016/08/22 - 10:44
Limit: FCC_Part15.209_RE(3m)	Margin: 0
Probe: N/A	Polarity: Horizontal
EUT: 001	Power: AC 120V/60Hz
Note: Mode 1: Transmit 802.11b at 2462MHz	

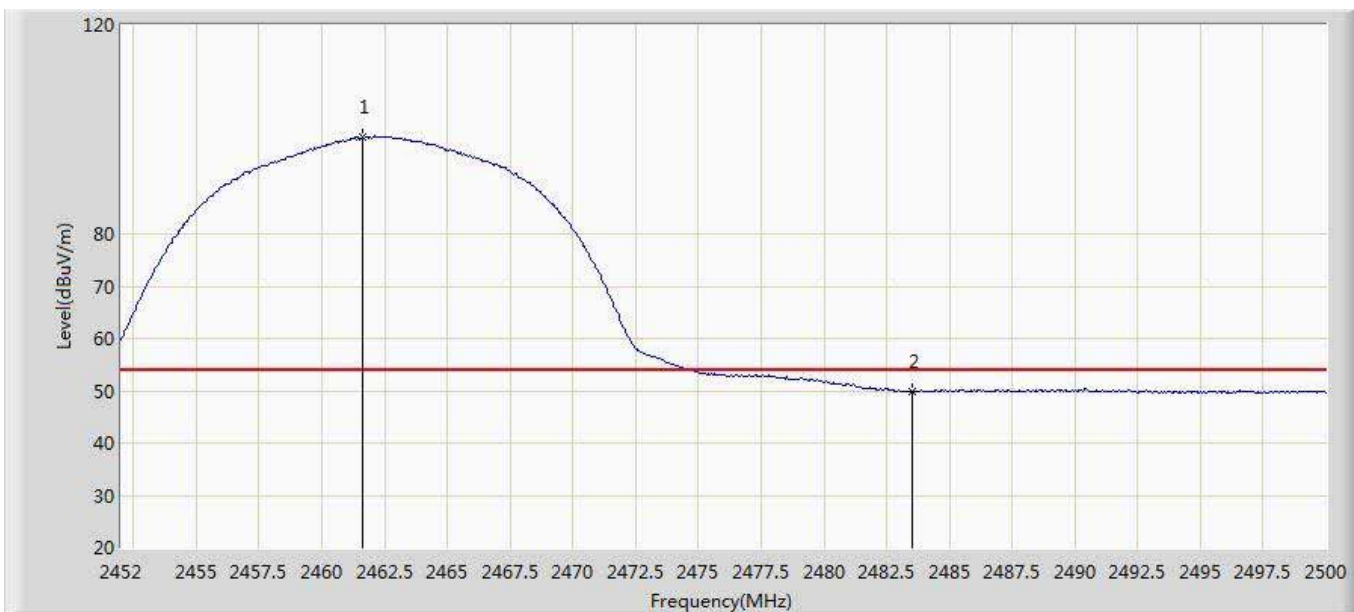

No	Mark	Frequency (MHz)	Measure Level (dBuV/m)	Reading Level (dBuV)	Over Limit (dB)	Limit (dBuV/m)	Factor (dB)	Type
1	*	2461.648	98.464	65.061	N/A	N/A	33.403	AV
2		2483.500	49.894	16.402	-4.106	54.000	33.493	AV

Note: Measure Level (dBμV/m) = Reading Level (dBμV) + Factor (dB)

Factor (dB) = Cable Loss (dB) + Antenna Factor (dB/m)



Site: AC102	Time: 2016/08/22 - 10:44
Limit: FCC_Part15.209_RE(3m)	Margin: 0
Probe: N/A	Polarity: Vertical
EUT: 001	Power: AC 120V/60Hz
Note: Mode 1: Transmit 802.11b at 2462MHz	

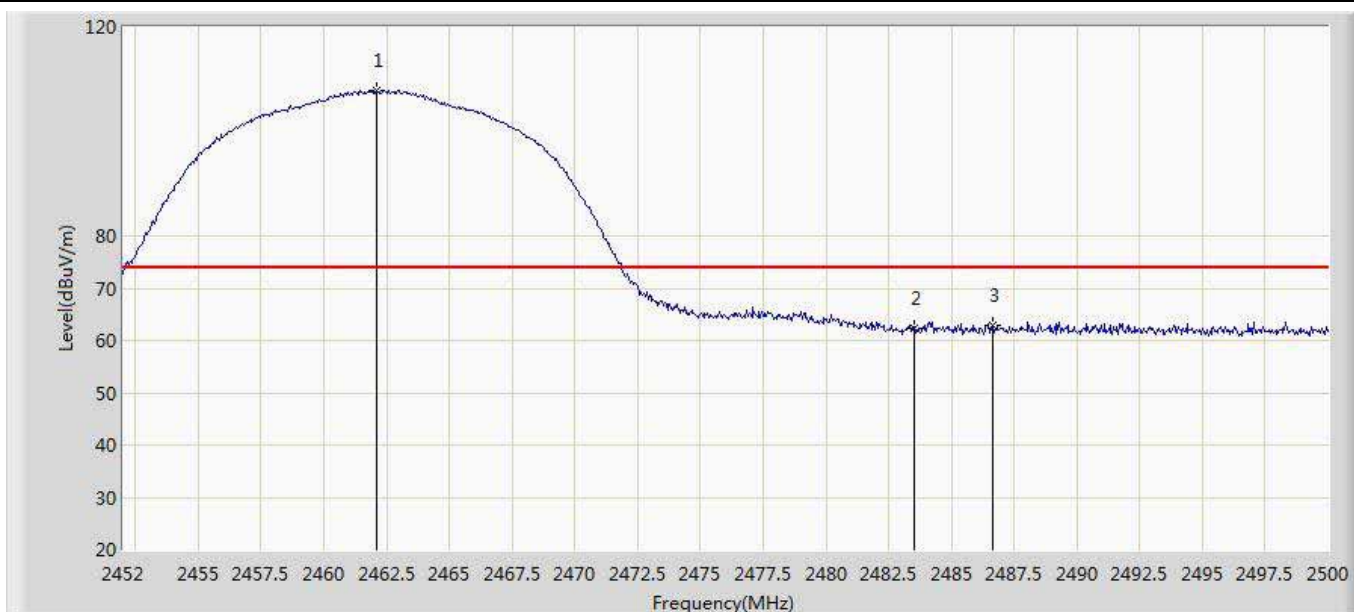

No	Mark	Frequency (MHz)	Measure Level (dBuV/m)	Reading Level (dBuV)	Over Limit (dB)	Limit (dBuV/m)	Factor (dB)	Type
1	*	2462.080	107.739	74.334	N/A	N/A	33.405	PK
2		2483.500	62.196	28.704	-11.804	74.000	33.493	PK
3		2486.656	63.036	29.531	-10.964	74.000	33.505	PK

Note: Measure Level (dBμV/m) = Reading Level (dBμV) + Factor (dB)

Factor (dB) = Cable Loss (dB) + Antenna Factor (dB/m)



Site: AC102	Time: 2016/08/22 - 10:48
Limit: FCC_Part15.209_RE(3m)	Margin: 0
Probe: N/A	Polarity: Vertical
EUT: 001	Power: AC 120V/60Hz
Note: Mode 1: Transmit 802.11b at 2462MHz	

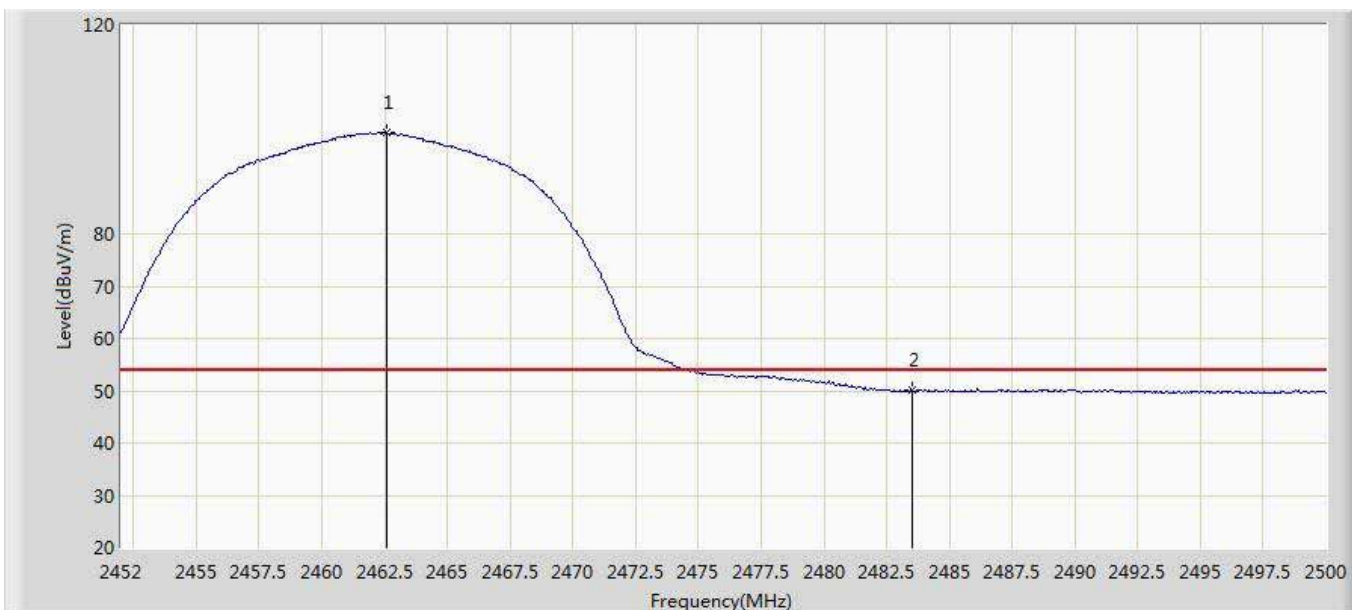

No	Mark	Frequency (MHz)	Measure Level (dBuV/m)	Reading Level (dBuV)	Over Limit (dB)	Limit (dBuV/m)	Factor (dB)	Type
1	*	2462.560	99.430	66.023	N/A	N/A	33.407	AV
2		2483.500	50.055	16.563	-3.945	54.000	33.493	AV

Note: Measure Level (dBμV/m) = Reading Level (dBμV) + Factor (dB)

Factor (dB) = Cable Loss (dB) + Antenna Factor (dB/m)



Site: AC102	Time: 2016/08/22 - 10:49
Limit: FCC_Part15.209_RE(3m)	Margin: 0
Probe: N/A	Polarity: Vertical
EUT: 001	Power: AC 120V/60Hz
Note: Mode 2: Transmit 802.11g at 2412MHz	

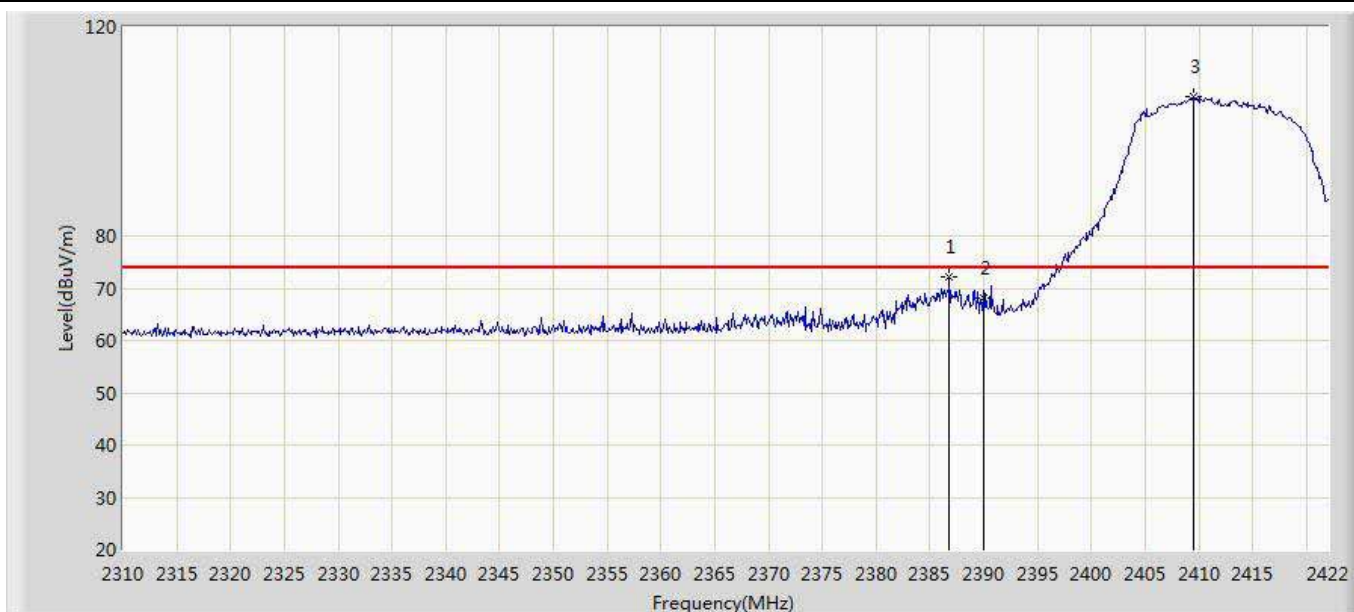

No	Mark	Frequency (MHz)	Measure Level (dBuV/m)	Reading Level (dBuV)	Over Limit (dB)	Limit (dBuV/m)	Factor (dB)	Type
1		2386.832	72.257	39.159	-1.743	74.000	33.098	PK
2		2390.000	68.049	34.938	-5.951	74.000	33.111	PK
3	*	2409.456	106.568	73.378	N/A	N/A	33.190	PK

Note: Measure Level (dBμV/m) = Reading Level (dBμV) + Factor (dB)

Factor (dB) = Cable Loss (dB) + Antenna Factor (dB/m)



Site: AC102	Time: 2016/08/22 - 11:04
Limit: FCC_Part15.209_RE(3m)	Margin: 0
Probe: N/A	Polarity: Vertical
EUT: 001	Power: AC 120V/60Hz
Note: Mode 2: Transmit 802.11g at 2412MHz	

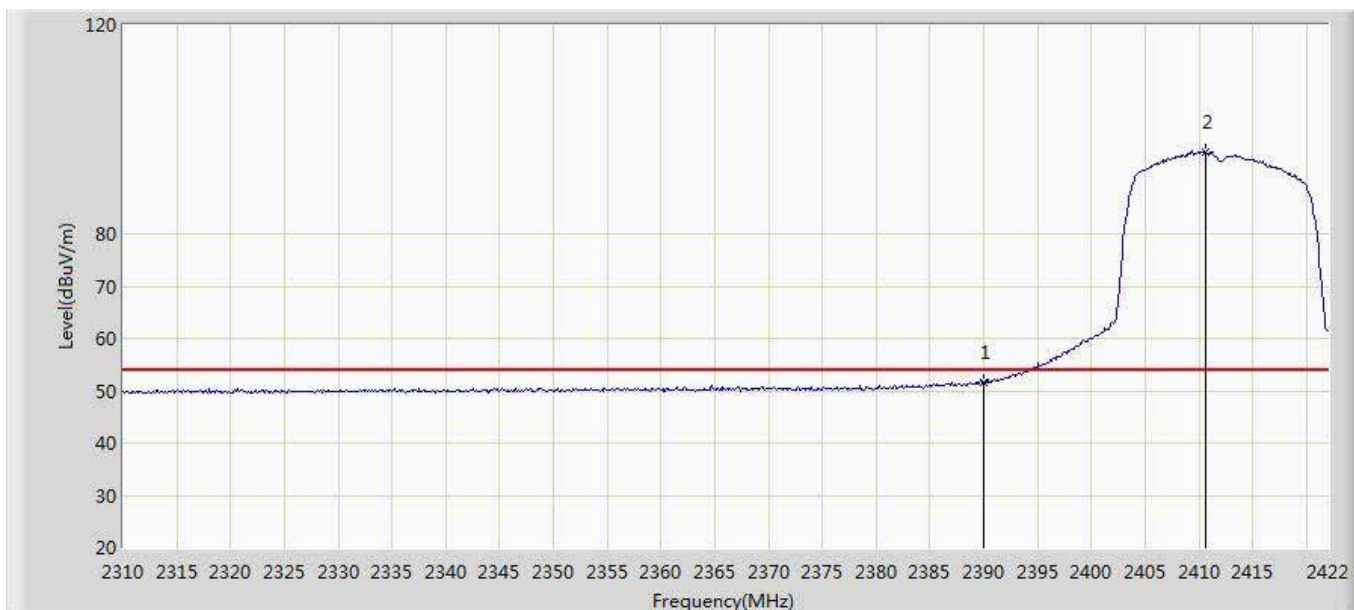

No	Mark	Frequency (MHz)	Measure Level (dBuV/m)	Reading Level (dBuV)	Over Limit (dB)	Limit (dBuV/m)	Factor (dB)	Type
1		2390.000	51.704	18.593	-2.296	54.000	33.111	AV
2	*	2410.576	95.733	62.538	N/A	N/A	33.195	AV

Note: Measure Level (dBμV/m) = Reading Level (dBμV) + Factor (dB)

Factor (dB) = Cable Loss (dB) + Antenna Factor (dB/m)



Site: AC102	Time: 2016/08/22 - 11:05
Limit: FCC_Part15.209_RE(3m)	Margin: 0
Probe: N/A	Polarity: Horizontal
EUT: 001	Power: AC 120V/60Hz
Note: Mode 2: Transmit 802.11g at 2412MHz	

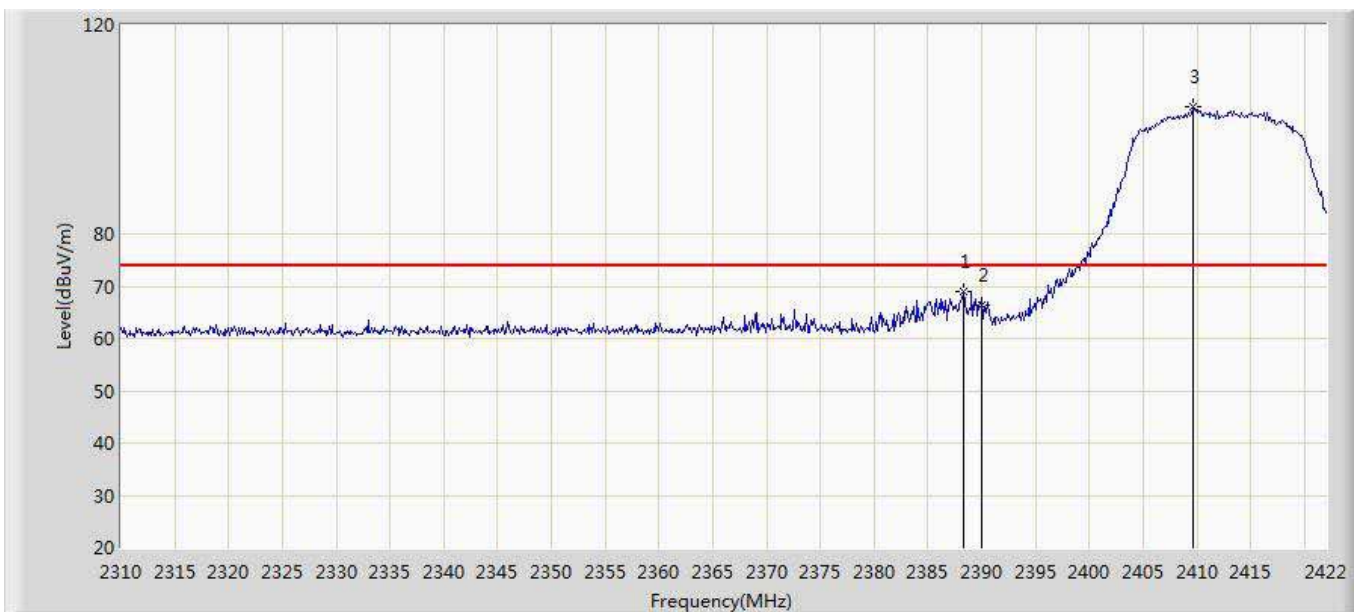

No	Mark	Frequency (MHz)	Measure Level (dBuV/m)	Reading Level (dBuV)	Over Limit (dB)	Limit (dBuV/m)	Factor (dB)	Type
1		2388.288	68.990	35.886	-5.010	74.000	33.104	PK
2		2390.000	66.264	33.153	-7.736	74.000	33.111	PK
3	*	2409.680	104.224	71.033	N/A	N/A	33.191	PK

Note: Measure Level (dBμV/m) = Reading Level (dBμV) + Factor (dB)

Factor (dB) = Cable Loss (dB) + Antenna Factor (dB/m)



Site: AC102	Time: 2016/08/22 - 11:10
Limit: FCC_Part15.209_RE(3m)	Margin: 0
Probe: N/A	Polarity: Horizontal
EUT: 001	Power: AC 120V/60Hz
Note: Mode 2: Transmit 802.11g at 2412MHz	

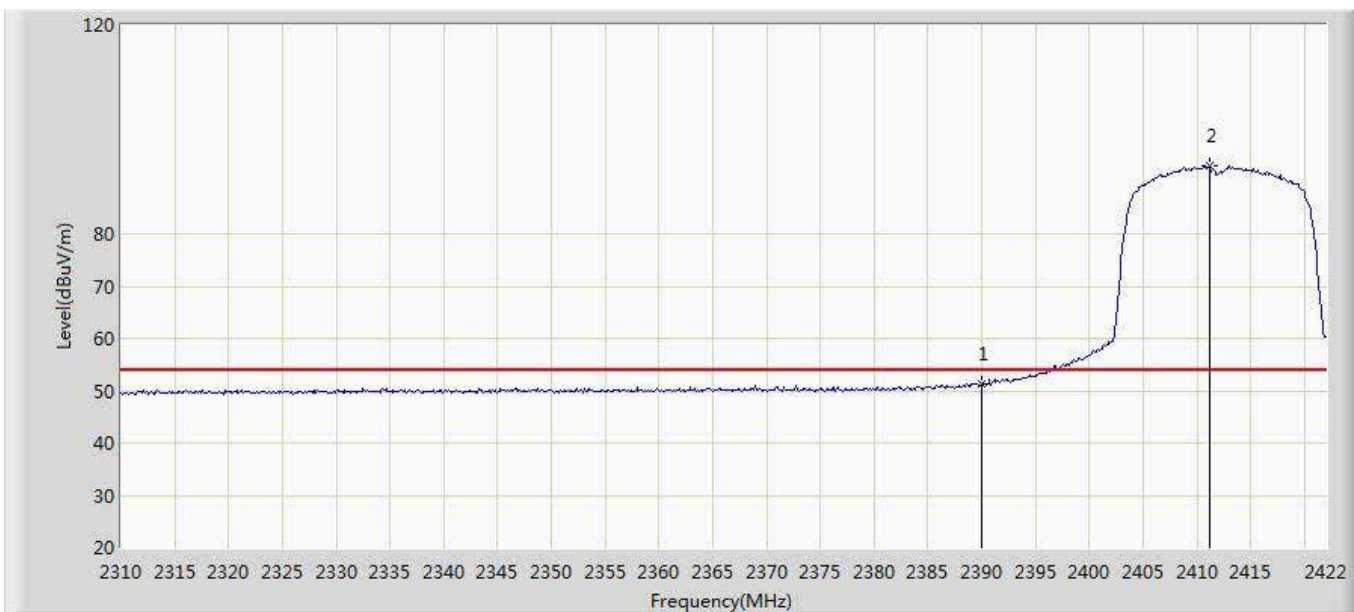

No	Mark	Frequency (MHz)	Measure Level (dBuV/m)	Reading Level (dBuV)	Over Limit (dB)	Limit (dBuV/m)	Factor (dB)	Type
1		2390.000	51.175	18.064	-2.825	54.000	33.111	AV
2	*	2411.248	92.965	59.767	N/A	N/A	33.198	AV

Note: Measure Level (dBμV/m) = Reading Level (dBμV) + Factor (dB)

Factor (dB) = Cable Loss (dB) + Antenna Factor (dB/m)



Site: AC102	Time: 2016/08/22 - 11:11
Limit: FCC_Part15.209_RE(3m)	Margin: 0
Probe: N/A	Polarity: Horizontal
EUT: 001	Power: AC 120V/60Hz
Note: Mode 2: Transmit 802.11g at 2462MHz	

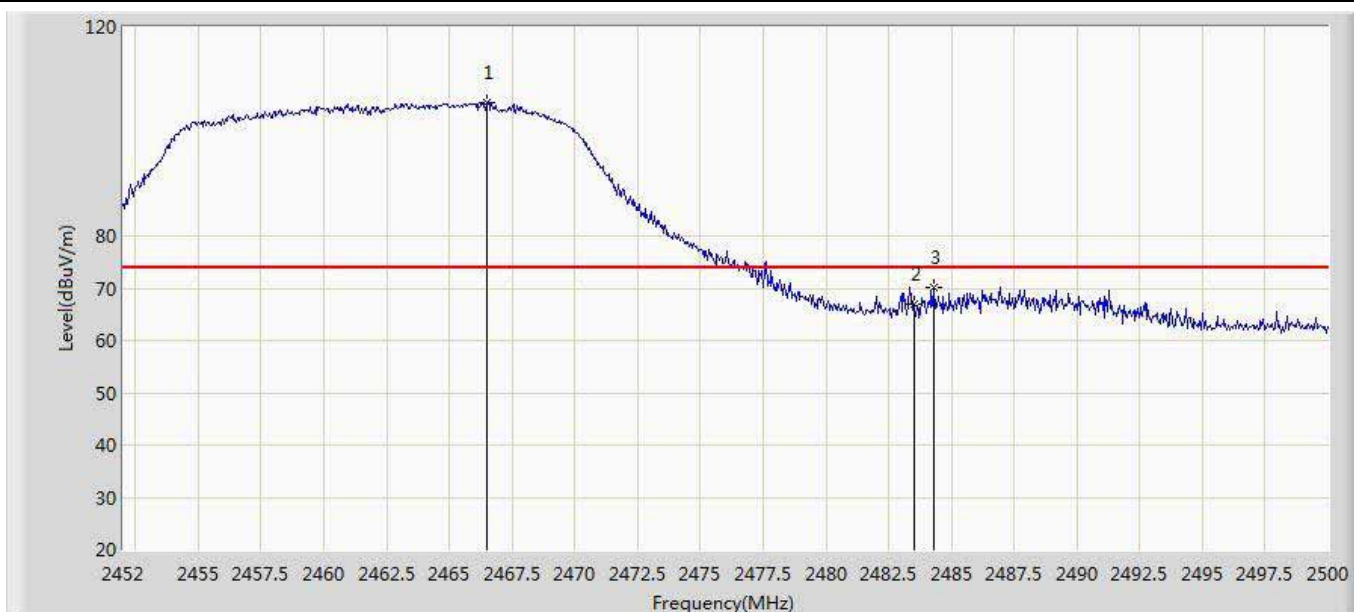

No	Mark	Frequency (MHz)	Measure Level (dBuV/m)	Reading Level (dBuV)	Over Limit (dB)	Limit (dBuV/m)	Factor (dB)	Type
1	*	2466.496	105.632	72.209	N/A	N/A	33.423	PK
2		2483.500	67.091	33.599	-6.909	74.000	33.493	PK
3		2484.304	70.267	36.771	-3.733	74.000	33.495	PK

Note: Measure Level (dBμV/m) = Reading Level (dBμV) + Factor (dB)

Factor (dB) = Cable Loss (dB) + Antenna Factor (dB/m)



Site: AC102	Time: 2016/08/22 - 11:16
Limit: FCC_Part15.209_RE(3m)	Margin: 0
Probe: N/A	Polarity: Horizontal
EUT: 001	Power: AC 120V/60Hz
Note: Mode 2: Transmit 802.11g at 2462MHz	

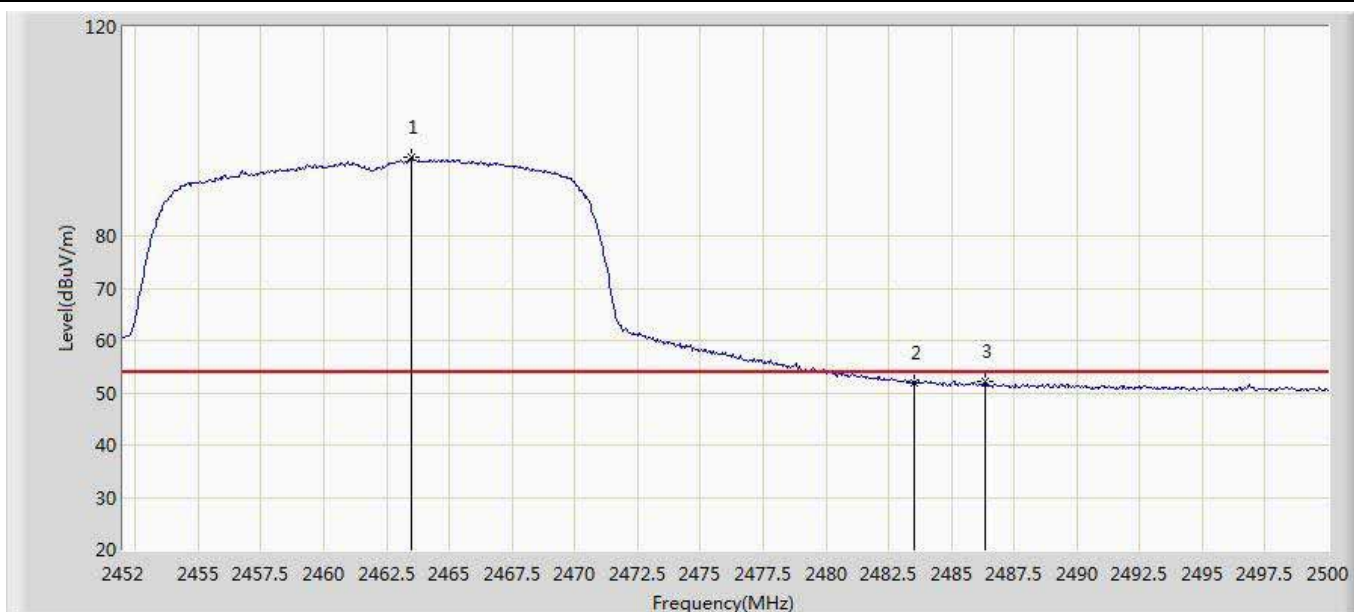

No	Mark	Frequency (MHz)	Measure Level (dBuV/m)	Reading Level (dBuV)	Over Limit (dB)	Limit (dBuV/m)	Factor (dB)	Type
1	*	2463.472	95.029	61.618	N/A	N/A	33.411	AV
2		2483.500	51.999	18.507	-2.001	54.000	33.493	AV
3		2486.368	52.182	18.678	-1.818	54.000	33.505	AV

Note: Measure Level (dBμV/m) = Reading Level (dBμV) + Factor (dB)

Factor (dB) = Cable Loss (dB) + Antenna Factor (dB/m)



Site: AC102	Time: 2016/08/22 - 11:16
Limit: FCC_Part15.209_RE(3m)	Margin: 0
Probe: N/A	Polarity: Vertical
EUT: 001	Power: AC 120V/60Hz
Note: Mode 2: Transmit 802.11g at 2462MHz	

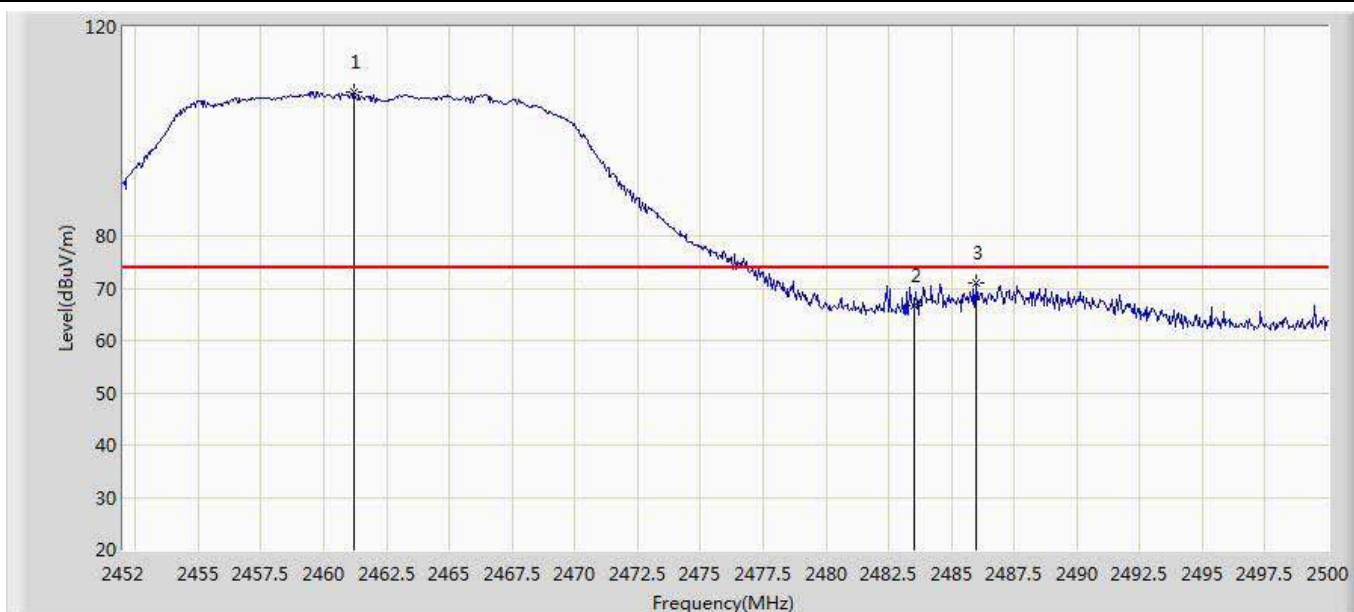

No	Mark	Frequency (MHz)	Measure Level (dBuV/m)	Reading Level (dBuV)	Over Limit (dB)	Limit (dBuV/m)	Factor (dB)	Type
1	*	2461.216	107.523	74.122	N/A	N/A	33.402	PK
2		2483.500	66.711	33.219	-7.289	74.000	33.493	PK
3		2485.984	71.126	37.624	-2.874	74.000	33.503	PK

Note: Measure Level (dBμV/m) = Reading Level (dBμV) + Factor (dB)

Factor (dB) = Cable Loss (dB) + Antenna Factor (dB/m)



Site: AC102	Time: 2016/08/22 - 11:25
Limit: FCC_Part15.209_RE(3m)	Margin: 0
Probe: N/A	Polarity: Vertical
EUT: 001	Power: AC 120V/60Hz
Note: Mode 2: Transmit 802.11g at 2462MHz	

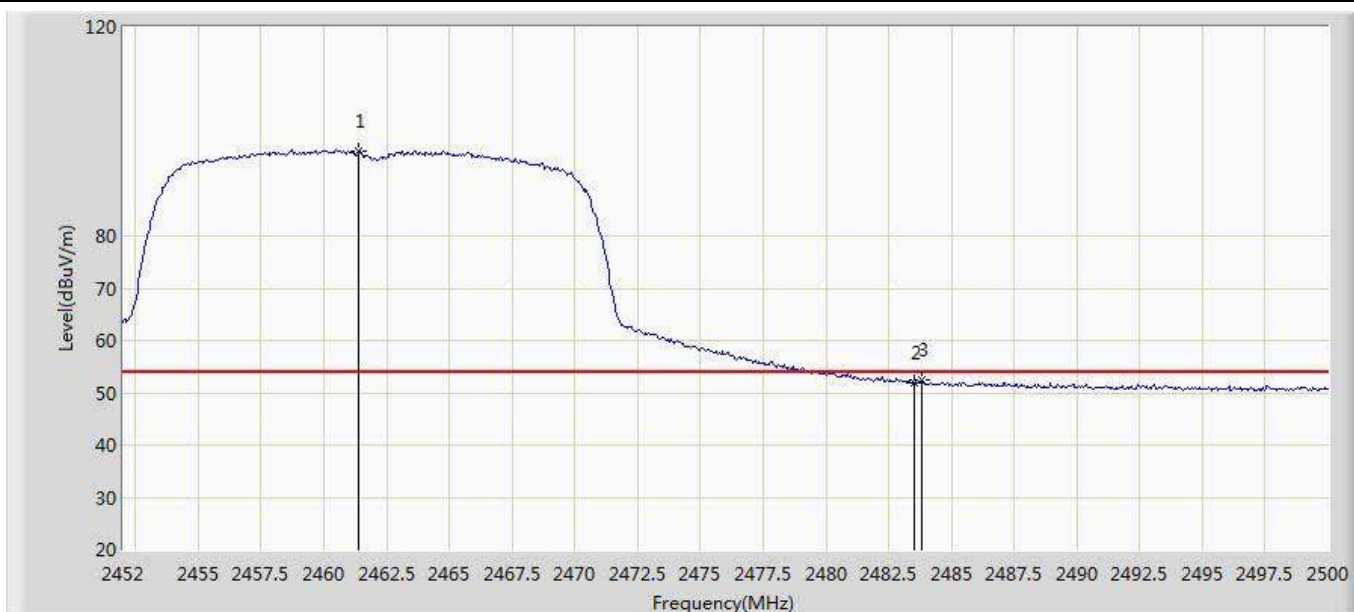

No	Mark	Frequency (MHz)	Measure Level (dBuV/m)	Reading Level (dBuV)	Over Limit (dB)	Limit (dBuV/m)	Factor (dB)	Type
1	*	2461.408	96.345	62.943	N/A	N/A	33.402	AV
2		2483.500	51.855	18.363	-2.145	54.000	33.493	AV
3		2483.824	52.395	18.901	-1.605	54.000	33.493	AV

Note: Measure Level (dBμV/m) = Reading Level (dBμV) + Factor (dB)

Factor (dB) = Cable Loss (dB) + Antenna Factor (dB/m)



Site: AC102	Time: 2016/08/22 - 11:26
Limit: FCC_Part15.209_RE(3m)	Margin: 0
Probe: N/A	Polarity: Vertical
EUT: 001	Power: AC 120V/60Hz
Note: Mode 3: Transmit 802.11n(20MHz) at 2412MHz	

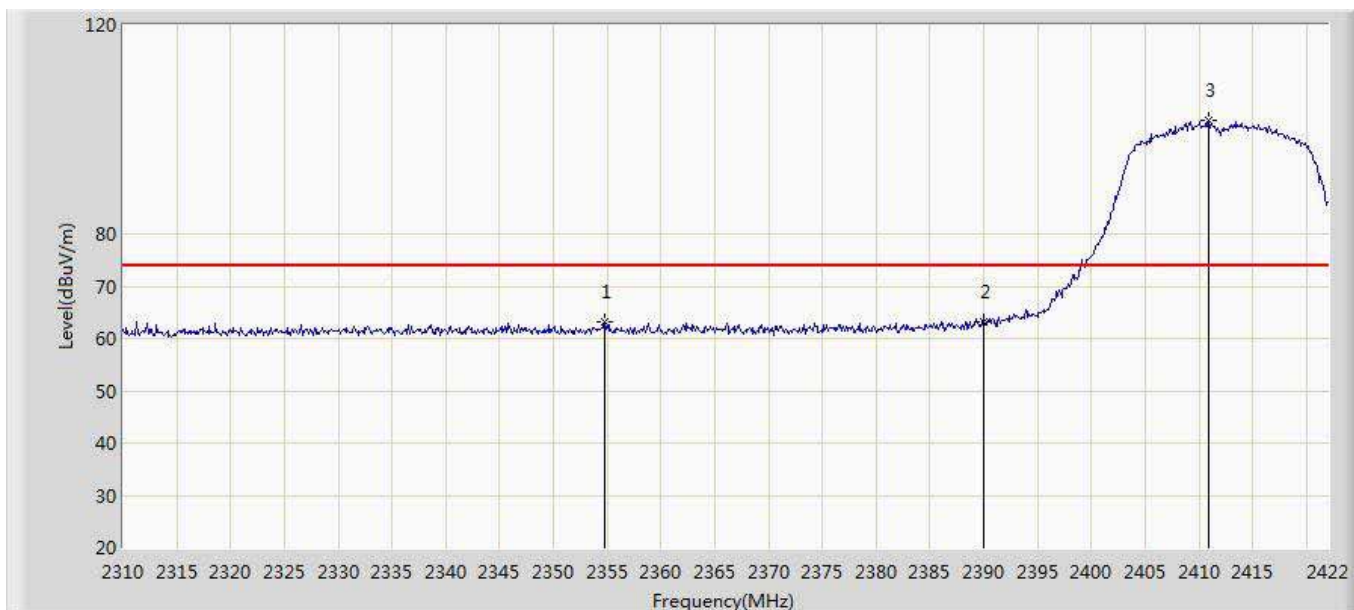

No	Mark	Frequency (MHz)	Measure Level (dBuV/m)	Reading Level (dBuV)	Over Limit (dB)	Limit (dBuV/m)	Factor (dB)	Type
1		2354.800	63.263	30.296	-10.737	74.000	32.967	PK
2		2390.000	63.325	30.214	-10.675	74.000	33.111	PK
3	*	2410.912	101.650	68.454	N/A	N/A	33.197	PK

Note: Measure Level (dBμV/m) = Reading Level (dBμV) + Factor (dB)

Factor (dB) = Cable Loss (dB) + Antenna Factor (dB/m)



Site: AC102	Time: 2016/08/22 - 11:33
Limit: FCC_Part15.209_RE(3m)	Margin: 0
Probe: N/A	Polarity: Vertical
EUT: 001	Power: AC 120V/60Hz
Note: Mode 3: Transmit 802.11n(20MHz) at 2412MHz	

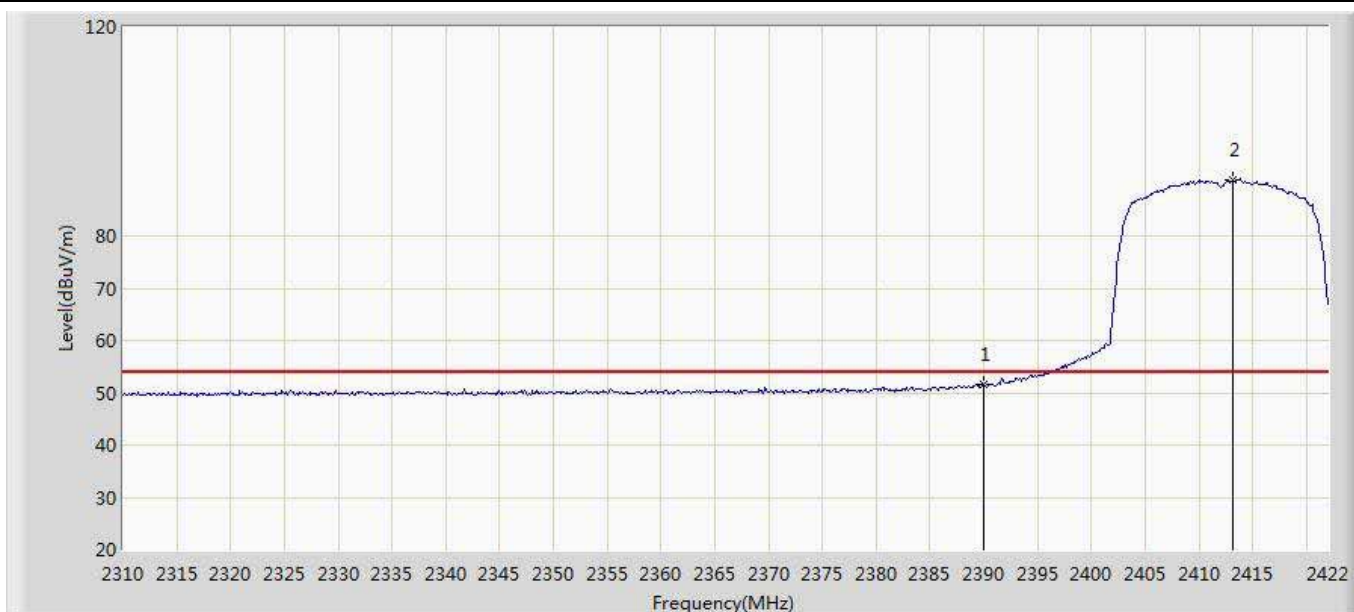

No	Mark	Frequency (MHz)	Measure Level (dBuV/m)	Reading Level (dBuV)	Over Limit (dB)	Limit (dBuV/m)	Factor (dB)	Type
1		2390.000	51.558	18.447	-2.442	54.000	33.111	AV
2	*	2413.152	90.658	57.453	N/A	N/A	33.205	AV

Note: Measure Level (dBμV/m) = Reading Level (dBμV) + Factor (dB)

Factor (dB) = Cable Loss (dB) + Antenna Factor (dB/m)



Site: AC102	Time: 2016/08/22 - 11:34
Limit: FCC_Part15.209_RE(3m)	Margin: 0
Probe: N/A	Polarity: Horizontal
EUT: 001	Power: AC 120V/60Hz
Note: Mode 3: Transmit 802.11n(20MHz) at 2412MHz	

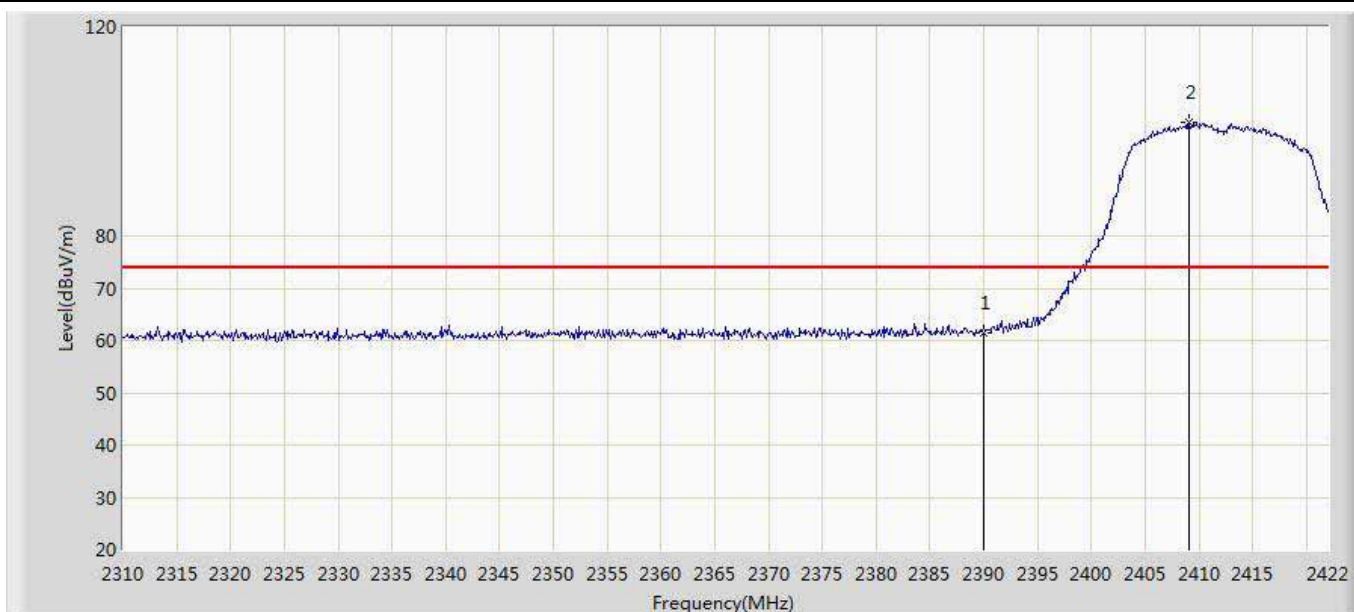

No	Mark	Frequency (MHz)	Measure Level (dBuV/m)	Reading Level (dBuV)	Over Limit (dB)	Limit (dBuV/m)	Factor (dB)	Type
1		2390.000	61.492	28.381	-12.508	74.000	33.111	PK
2	*	2409.120	101.833	68.644	N/A	N/A	33.189	PK

Note: Measure Level (dBμV/m) = Reading Level (dBμV) + Factor (dB)

Factor (dB) = Cable Loss (dB) + Antenna Factor (dB/m)



Site: AC102	Time: 2016/08/22 - 11:38
Limit: FCC_Part15.209_RE(3m)	Margin: 0
Probe: N/A	Polarity: Horizontal
EUT: 001	Power: AC 120V/60Hz
Note: Mode 3: Transmit 802.11n(20MHz) at 2412MHz	

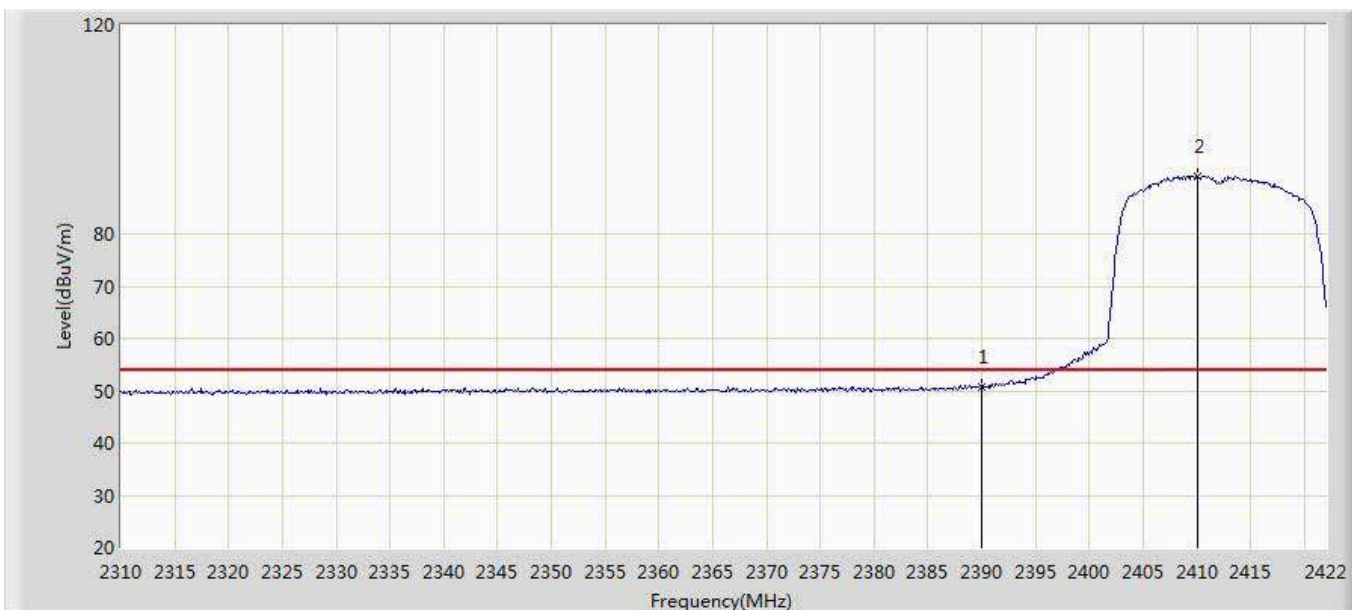

No	Mark	Frequency (MHz)	Measure Level (dBuV/m)	Reading Level (dBuV)	Over Limit (dB)	Limit (dBuV/m)	Factor (dB)	Type
1		2390.000	50.858	17.747	-3.142	54.000	33.111	AV
2	*	2410.128	91.027	57.834	N/A	N/A	33.193	AV

Note: Measure Level (dBμV/m) = Reading Level (dBμV) + Factor (dB)

Factor (dB) = Cable Loss (dB) + Antenna Factor (dB/m)



Site: AC102	Time: 2016/08/22 - 11:53
Limit: FCC_Part15.209_RE(3m)	Margin: 0
Probe: N/A	Polarity: Horizontal
EUT: 001	Power: AC 120V/60Hz
Note: Mode 3: Transmit 802.11n(20MHz) at 2462MHz	

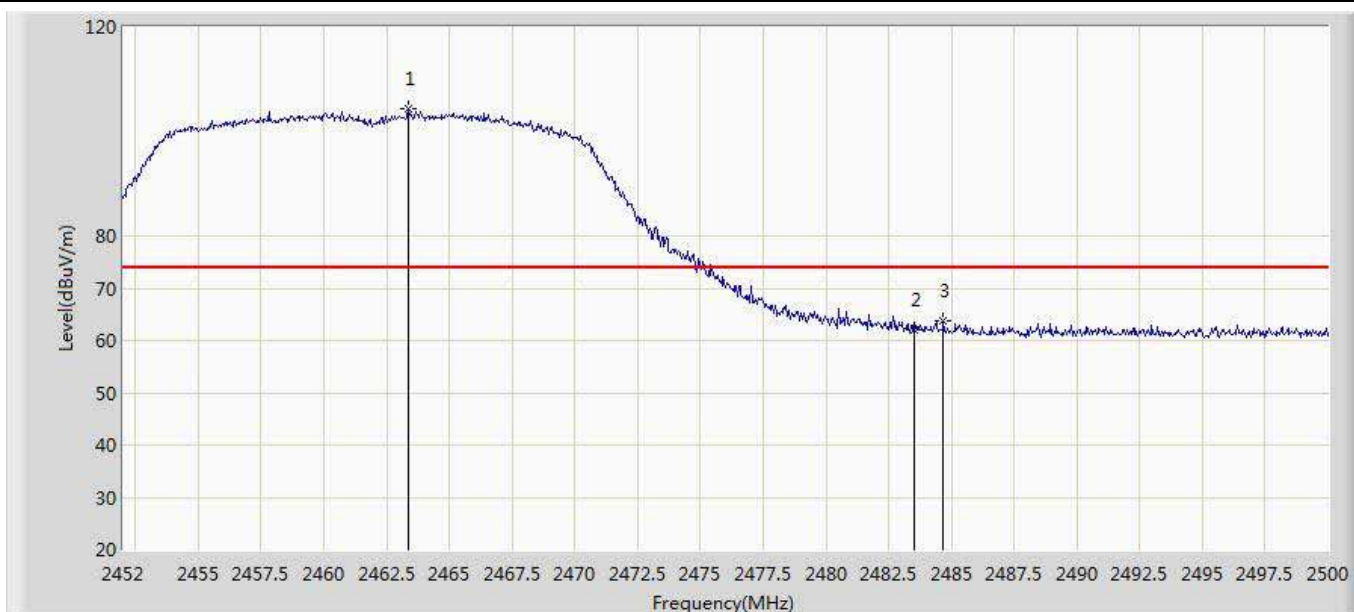

No	Mark	Frequency (MHz)	Measure Level (dBuV/m)	Reading Level (dBuV)	Over Limit (dB)	Limit (dBuV/m)	Factor (dB)	Type
1	*	2463.376	104.370	70.960	N/A	N/A	33.410	PK
2		2483.500	61.971	28.479	-12.029	74.000	33.493	PK
3		2484.688	63.633	30.136	-10.367	74.000	33.497	PK

Note: Measure Level (dBμV/m) = Reading Level (dBμV) + Factor (dB)

Factor (dB) = Cable Loss (dB) + Antenna Factor (dB/m)



Site: AC102	Time: 2016/08/22 - 11:57
Limit: FCC_Part15.209_RE(3m)	Margin: 0
Probe: N/A	Polarity: Horizontal
EUT: 001	Power: AC 120V/60Hz
Note: Mode 3: Transmit 802.11n(20MHz) at 2462MHz	

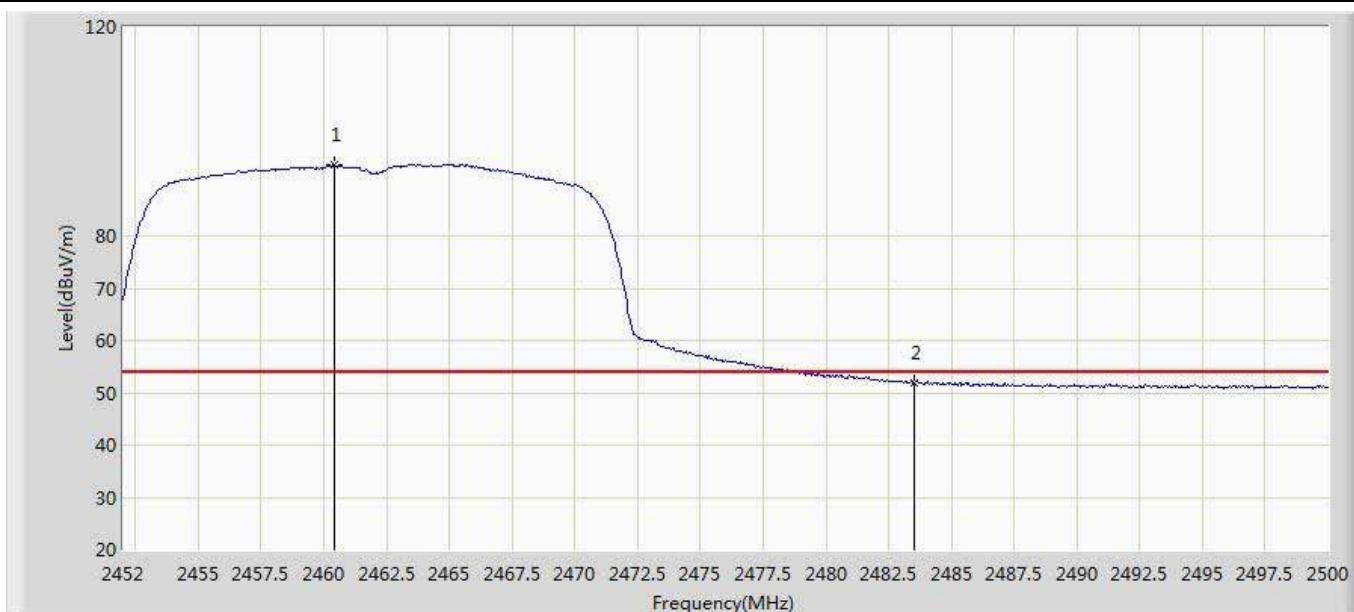

No	Mark	Frequency (MHz)	Measure Level (dBuV/m)	Reading Level (dBuV)	Over Limit (dB)	Limit (dBuV/m)	Factor (dB)	Type
1	*	2460.400	93.520	60.122	N/A	N/A	33.398	AV
2		2483.500	52.016	18.524	-1.984	54.000	33.493	AV

Note: Measure Level (dBμV/m) = Reading Level (dBμV) + Factor (dB)

Factor (dB) = Cable Loss (dB) + Antenna Factor (dB/m)



Site: AC102	Time: 2016/08/22 - 12:02
Limit: FCC_Part15.209_RE(3m)	Margin: 0
Probe: N/A	Polarity: Vertical
EUT: 001	Power: AC 120V/60Hz
Note: Mode 3: Transmit 802.11n(20MHz) at 2462MHz	

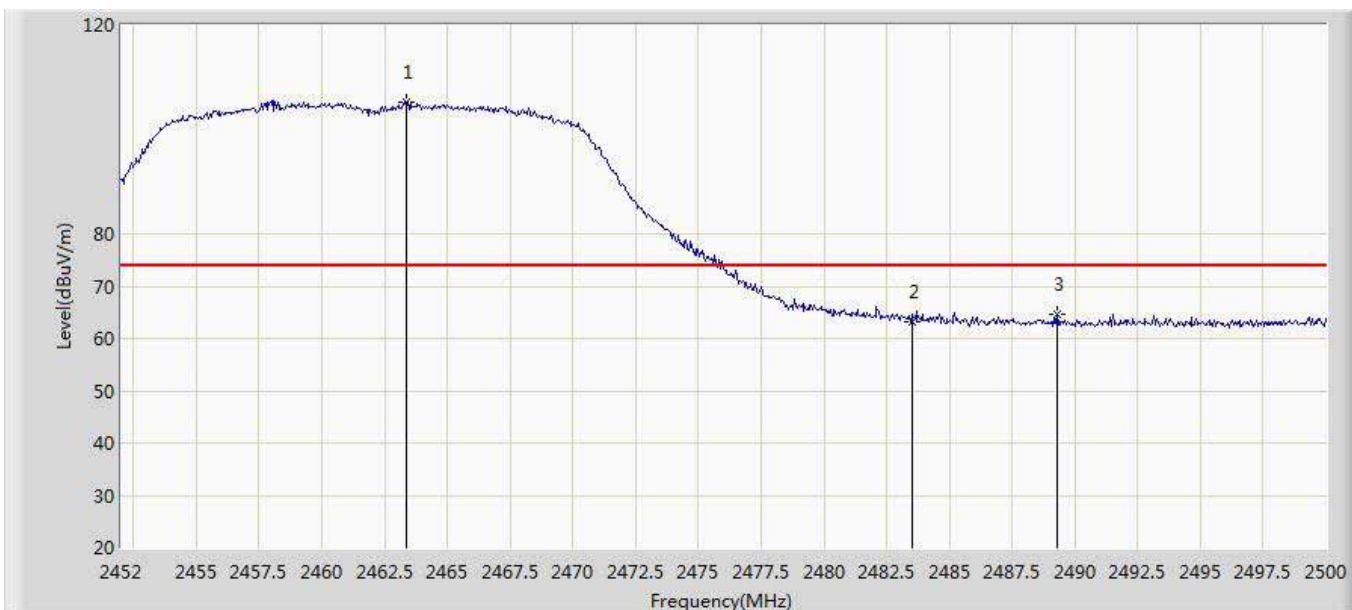

No	Mark	Frequency (MHz)	Measure Level (dBuV/m)	Reading Level (dBuV)	Over Limit (dB)	Limit (dBuV/m)	Factor (dB)	Type
1	*	2463.376	105.356	71.946	N/A	N/A	33.410	PK
2		2483.500	63.205	29.713	-10.795	74.000	33.493	PK
3		2489.296	64.568	31.052	-9.432	74.000	33.516	PK

Note: Measure Level (dBμV/m) = Reading Level (dBμV) + Factor (dB)

Factor (dB) = Cable Loss (dB) + Antenna Factor (dB/m)



Site: AC102	Time: 2016/08/22 - 12:10
Limit: FCC_Part15.209_RE(3m)	Margin: 0
Probe: N/A	Polarity: Vertical
EUT: 001	Power: AC 120V/60Hz
Note: Mode 3: Transmit 802.11n(20MHz) at 2462MHz	

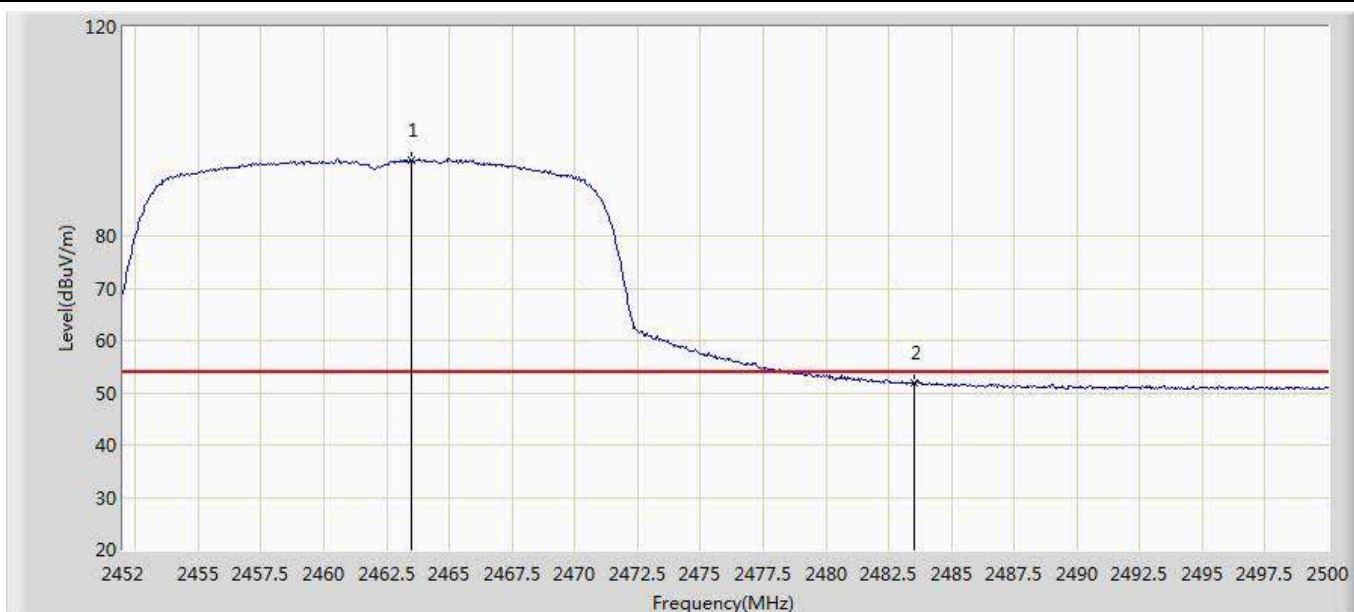

No	Mark	Frequency (MHz)	Measure Level (dBuV/m)	Reading Level (dBuV)	Over Limit (dB)	Limit (dBuV/m)	Factor (dB)	Type
1	*	2463.472	94.402	60.991	N/A	N/A	33.411	AV
2		2483.500	51.933	18.441	-2.067	54.000	33.493	AV

Note: Measure Level (dBμV/m) = Reading Level (dBμV) + Factor (dB)

Factor (dB) = Cable Loss (dB) + Antenna Factor (dB/m)



Band Edge (20dBc RF Conducted Measurement)

Mode 1: Transmit by 802.11b (2412MHz)

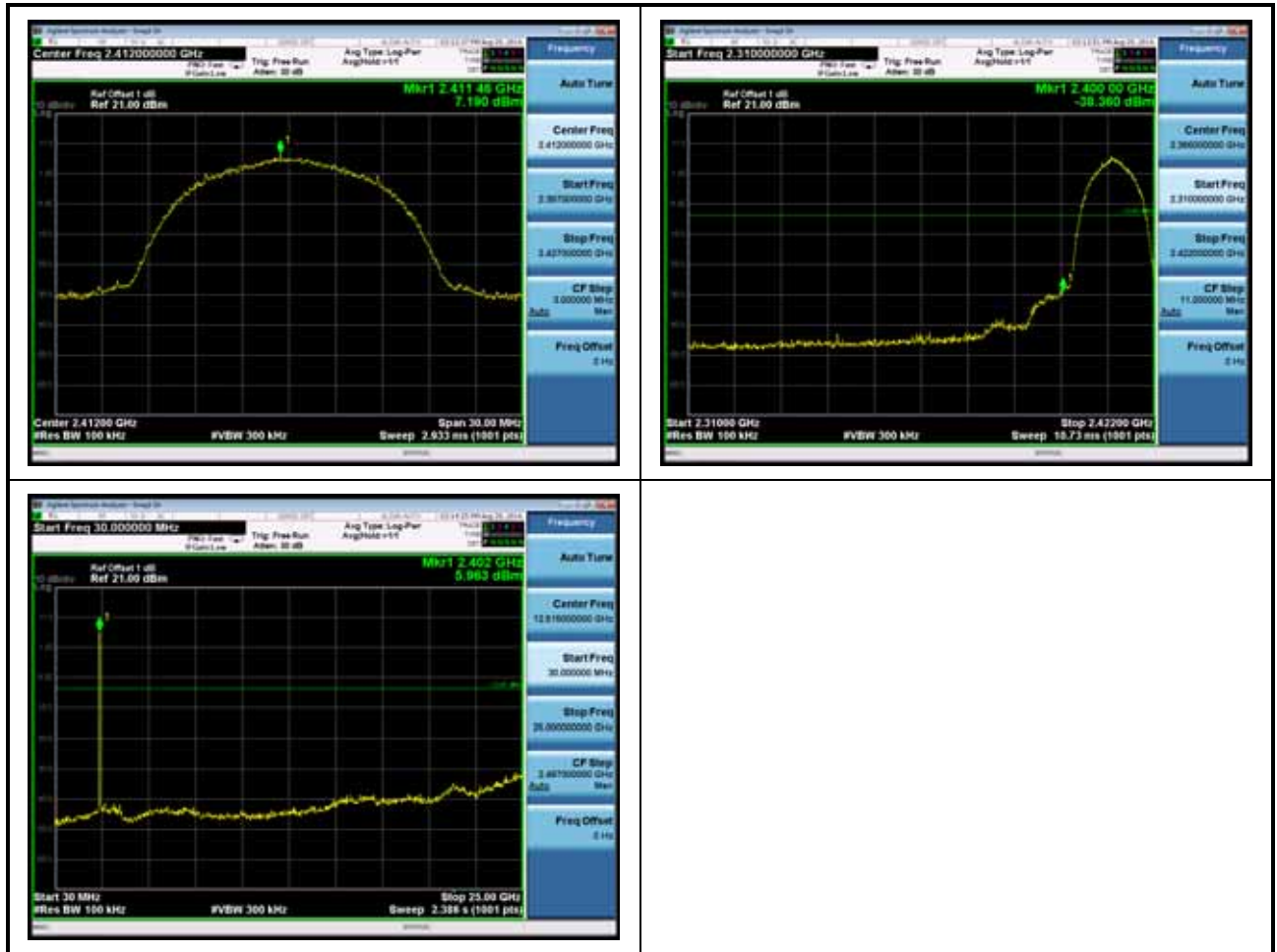



Mode 1: Transmit by 802.11b (2437MHz)

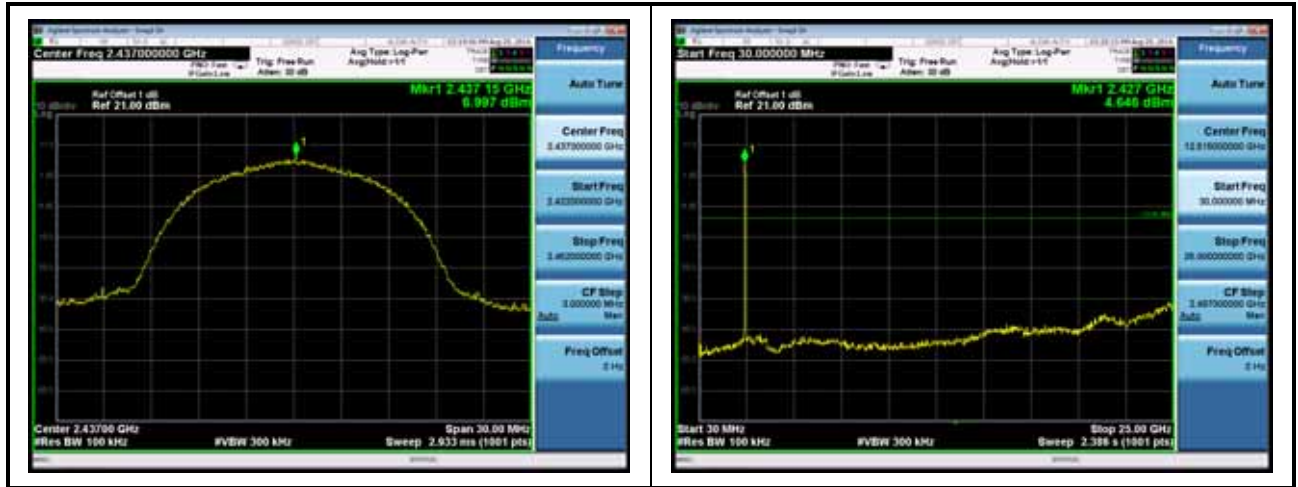

Mode 1: Transmit by 802.11b (2462MHz)

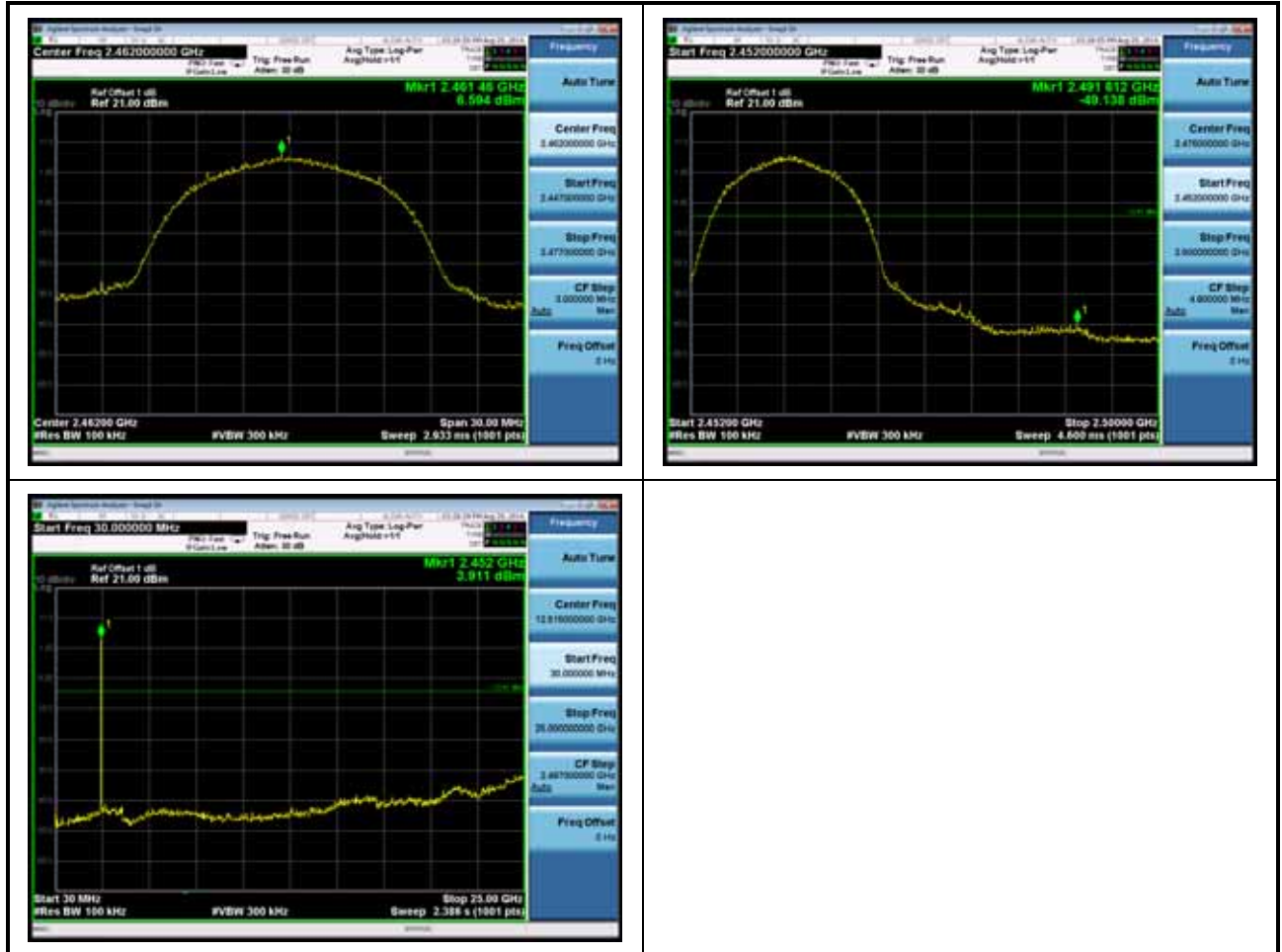



Mode 2: Transmit by 802.11g (2412MHz)

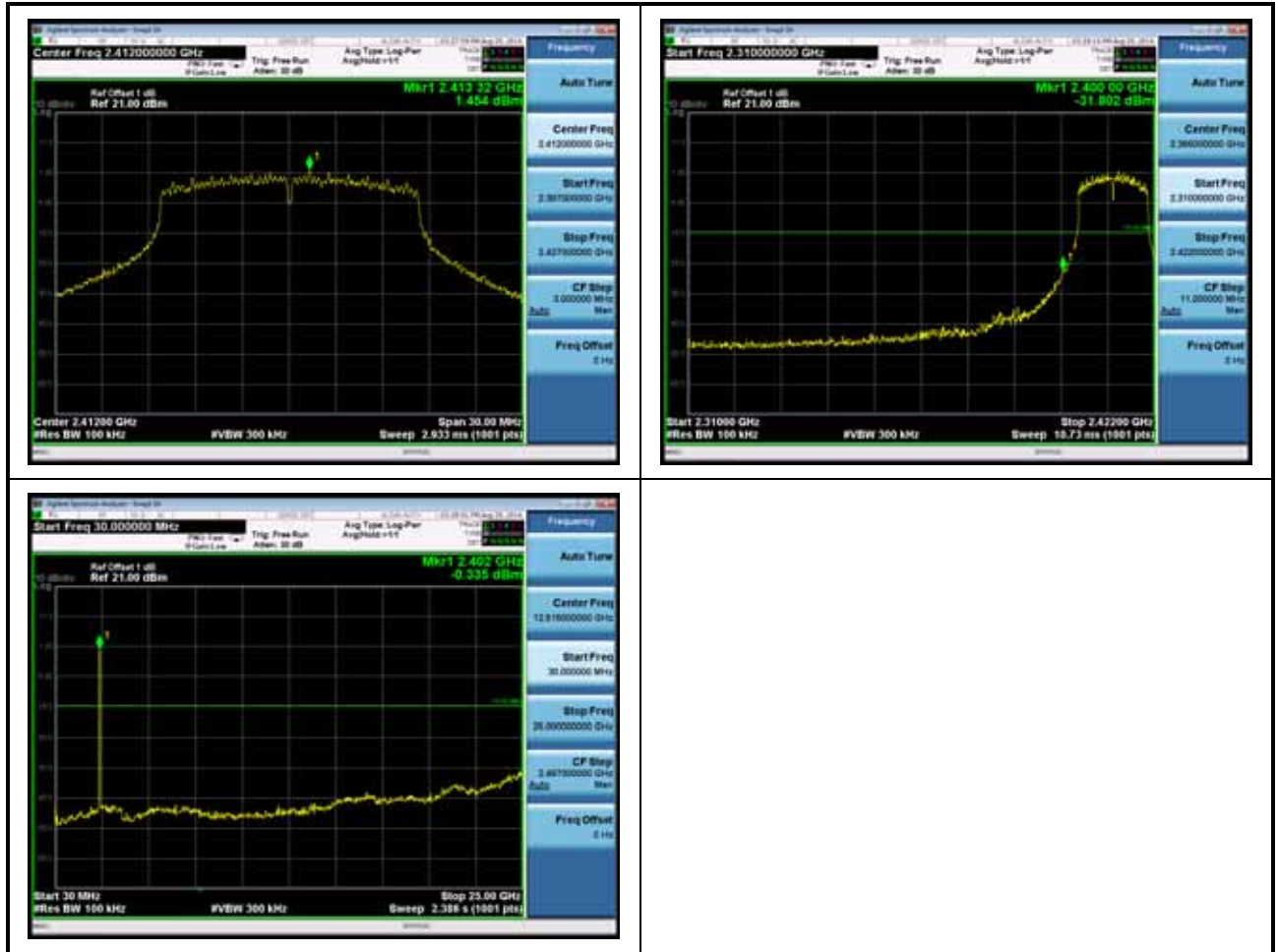



Mode 2: Transmit by 802.11g (2437MHz)

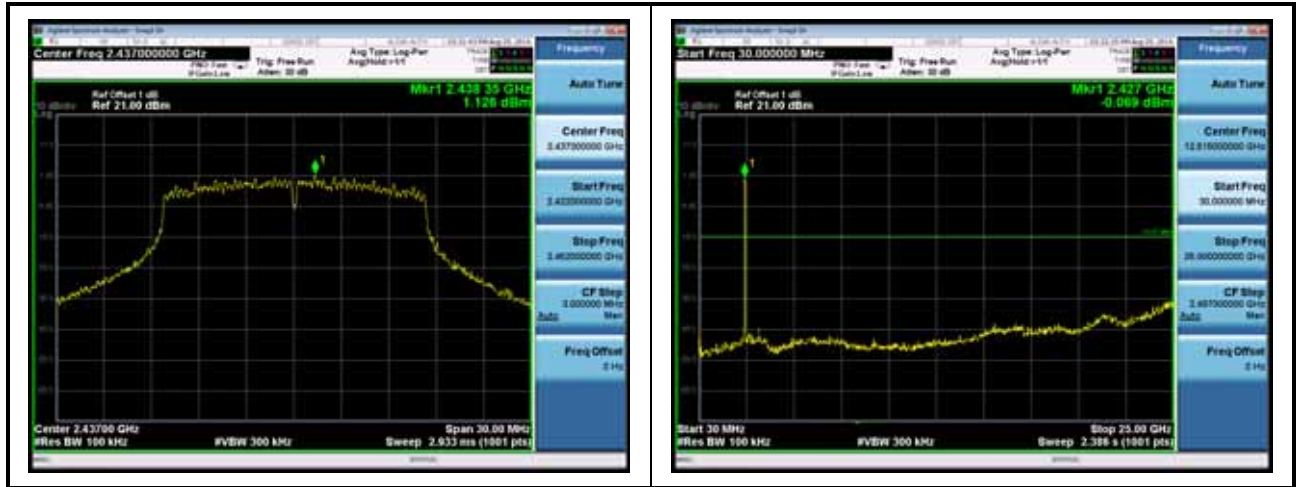

Mode 2: Transmit by 802.11g (2462MHz)

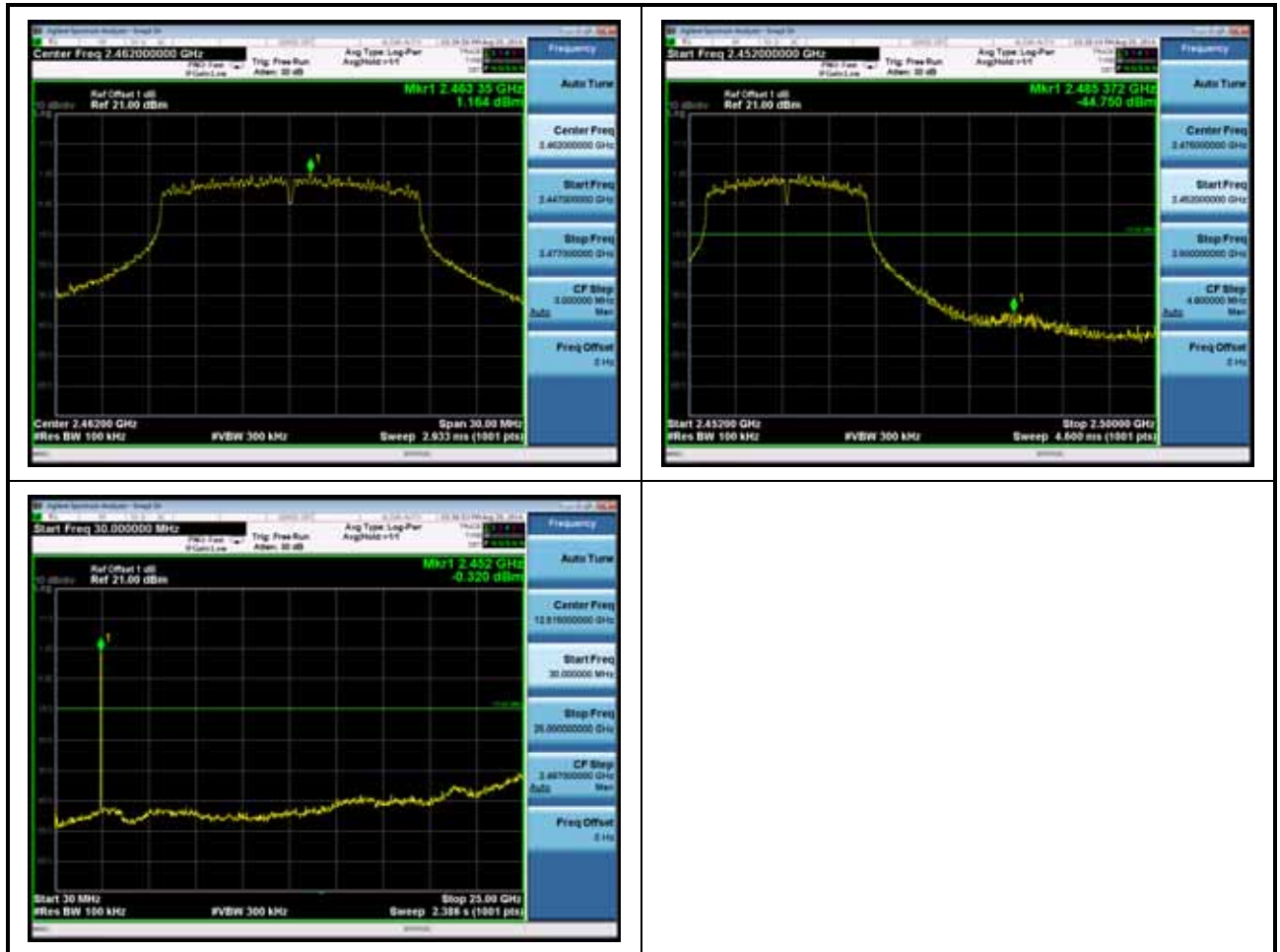



Mode 3: Transmit by 802.11n(20MHz) (2412MHz)

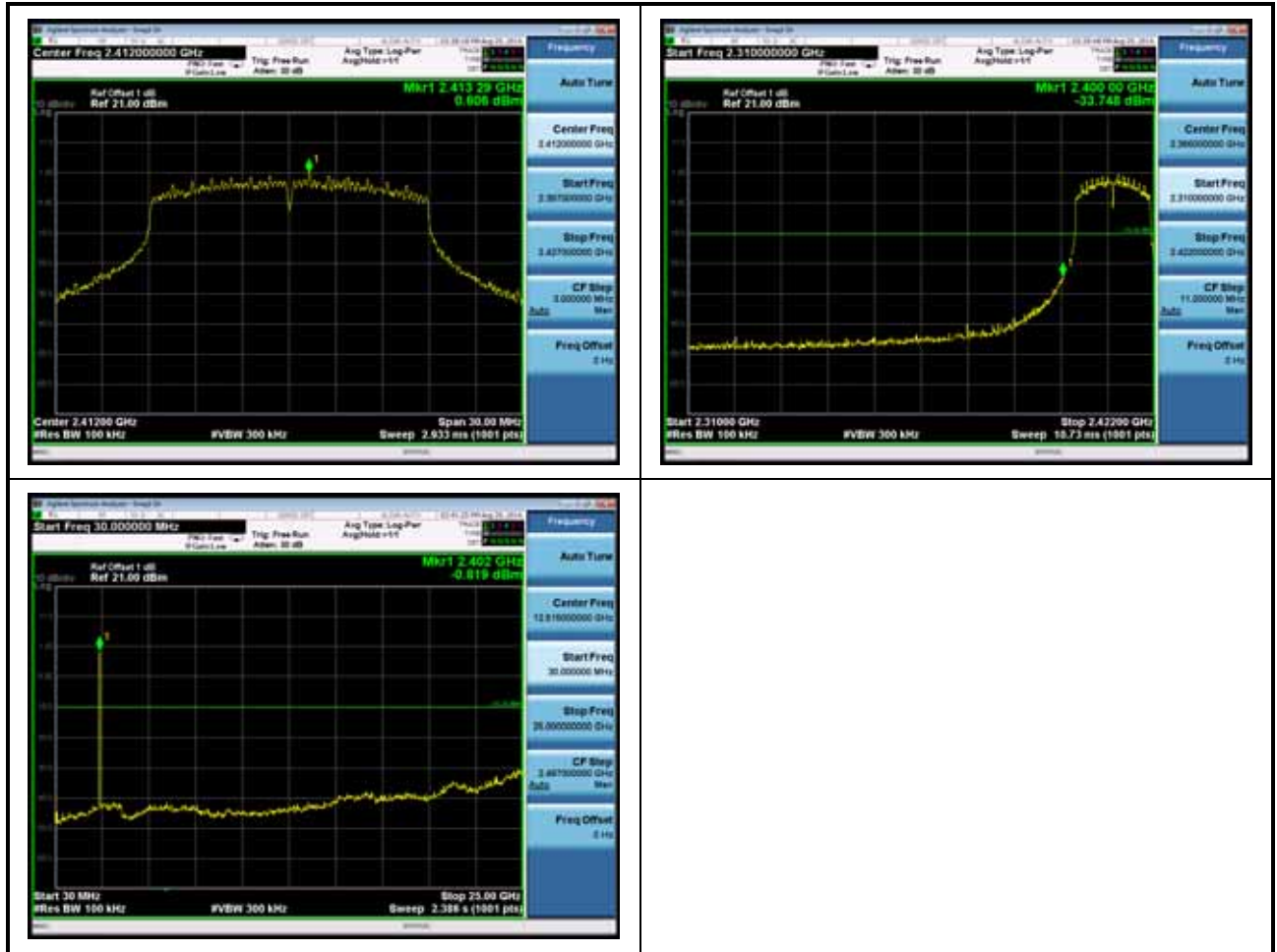



Mode 3: Transmit by 802.11n(20MHz) (2437MHz)

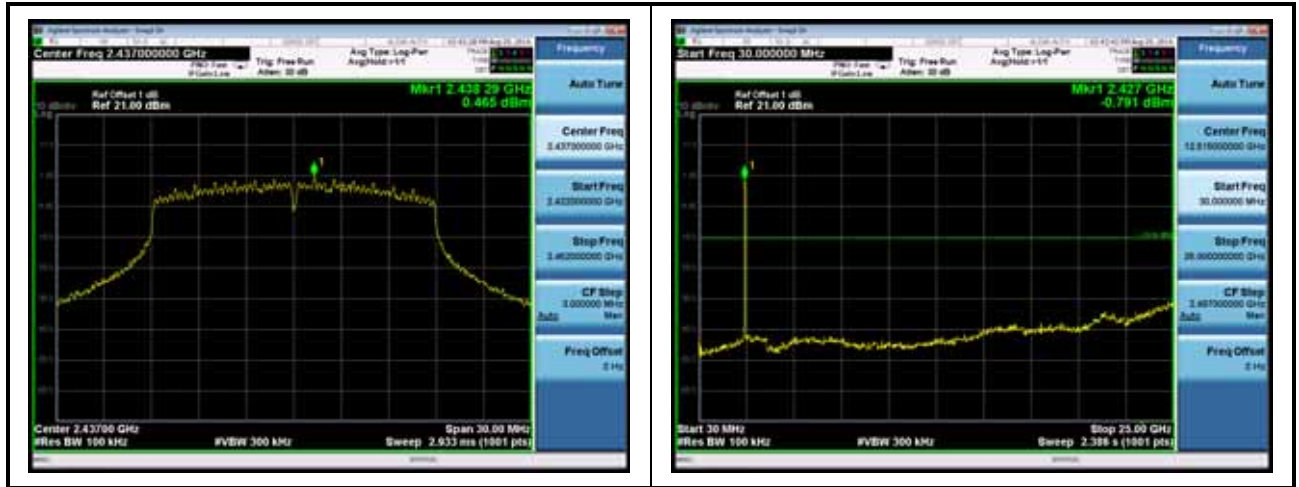

Mode 3: Transmit by 802.11n(20MHz) (2462MHz)

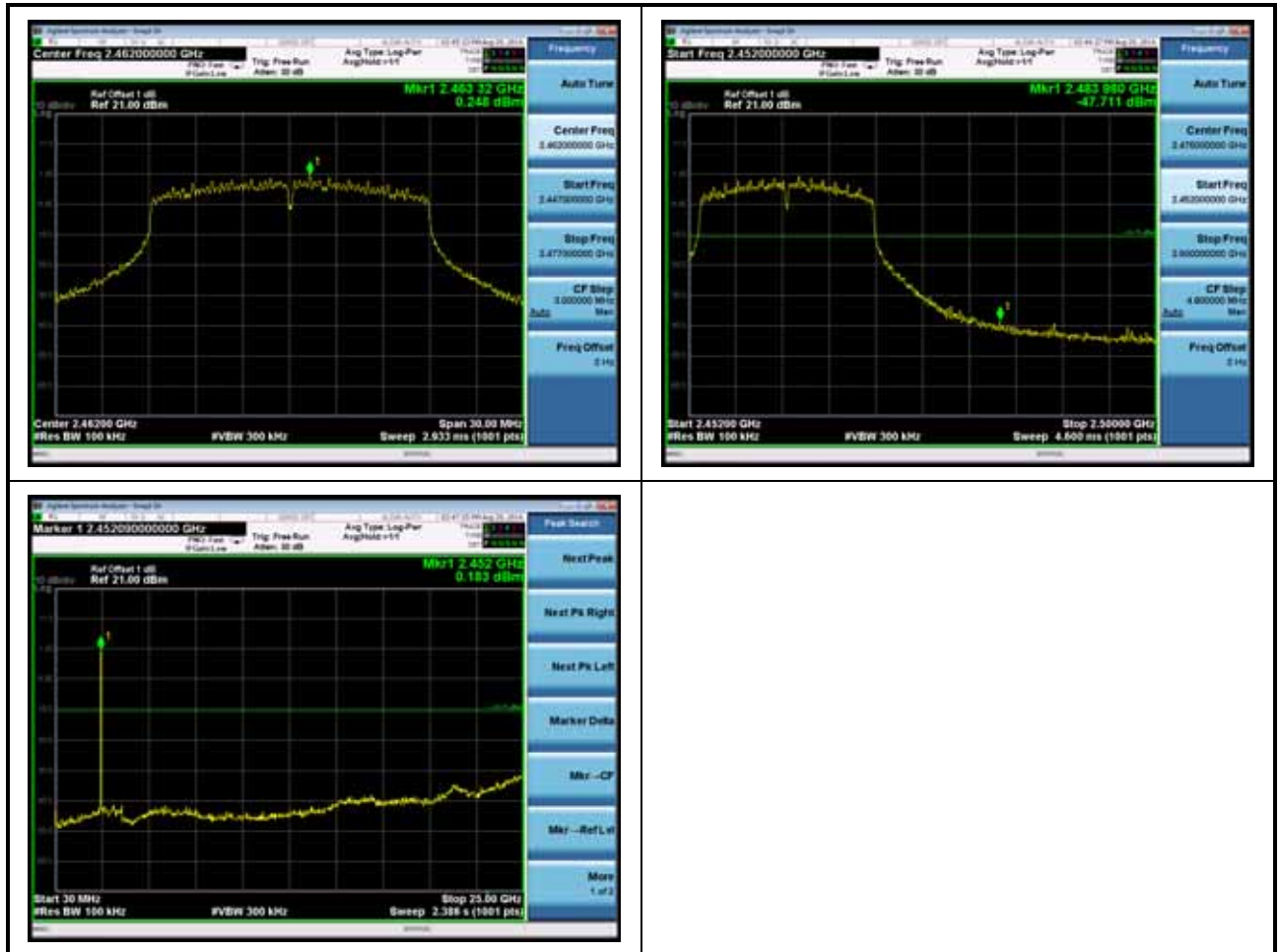



10. Restricted Bands of Operation

Only spurious emissions are permitted in any of the frequency bands listed below:

MHz	MHz	MHz	GHz
0.09000 – 0.11000	16.42000 – 16.42300	399.9 – 410.0	4.500 – 5.250
0.49500 – 0.505**	16.69475 – 16.69525	608.0 – 614.0	5.350 – 5.460
2.17350 – 2.19050	16.80425 – 16.80475	960.0 – 1240.0	7.250 – 7.750
4.12500 – 4.12800	25.50000 – 25.67000	1300.0 – 1427.0	8.025 – 8.500
4.17725 – 4.17775	37.50000 – 38.25000	1435.0 – 1626.5	9.000 – 9.200
4.20725 – 4.20775	73.00000 – 74.60000	1645.5 – 1646.5	9.300 – 9.500
6.21500 – 6.21800	74.80000 – 75.20000	1660.0 – 1710.0	10.600 – 12.700
6.26775 – 6.26825	108.00000 – 121.94000	1718.8 – 1722.2	13.250 – 13.400
6.31175 – 6.31225	123.00000 – 138.00000	2200.0 – 2300.0	14.470 – 14.500
8.29100 – 8.29400	149.90000 – 150.05000	2310.0 – 2390.0	15.350 – 16.200
8.36200 – 8.36600	156.52475 – 156.52525	2483.5 – 2500.0	17.700 – 21.400
8.37625 – 8.38675	156.70000 – 156.90000	2655.0 – 2900.0	22.010 – 23.120
8.41425 – 8.41475	162.01250 – 167.17000	3260.0 – 3267.0	23.600 – 24.000
12.29000 – 12.29300	167.72000 – 173.20000	3332.0 – 3339.0	31.200 – 31.800
12.51975 – 12.52025	240.00000 – 285.00000	3345.8 – 3358.0	36.430 – 36.500
12.57675 – 12.57725	322.00000 – 335.40000	3600.0 – 4400.0	Above 38.6
13.36000 – 13.41000			

** : Until February 1, 1999, this restricted band shall be 0.490-0.510 MHz

10.1 Labeling Requirement

The device shall bear the following statement in a conspicuous location on the device:

This device complies with part 15 of the FCC Rules. Operation is subject to the following two conditions:

- (1) This device may not cause harmful interference, and
- (2) this device must accept any interference received, including interference that may cause undesired operation.