

FCC TEST REPORT
for
Shenzhen Bominwell Robotics Co., Ltd.

Peek Relay
Model No.: PERE

Prepared for : Shenzhen Bominwell Robotics Co., Ltd.
Address : JK Units, 5F, Building 7, Baoneng Sci&Tech Park, Longhua
Dist., Shenzhen, China

Prepared By : Shenzhen Anbotek Compliance Laboratory Limited
Address : 1/F., Building 1, SEC Industrial Park, No.0409 Qianhai Road,
Nanshan District, Shenzhen, Guangdong, China
Tel: (86) 755-26066544
Fax: (86) 755-26014772

Report Number : R011606070I
Date of Test : Jun. 02~ 17, 2016
Date of Report : Jun. 20, 2016

TABLE OF CONTENT

Description

Page

Test Report

1. GENERAL INFORMATION.....	4
1.1. Description of Device (EUT).....	4
1.2. Auxiliary Equipment Used during Test.....	5
1.3. Description of Test Facility.....	5
1.4. Measurement Uncertainty.....	5
2. TEST METHODOLOGY.....	6
2.1. Summary of Test Results.....	6
2.2. Description of Test Modes.....	6
2.3. List of channels:.....	7
3. FCC Part 15.247 Requirements for DSSS & OFDM Modulation.....	8
3.1 Test Setup.....	8
3.2 6dB Bandwidth.....	8
3.3. Maximum Output Power Test.....	22
3.4. Band Edges Measurement.....	30
3.5. Peak Power Spectral Density.....	100
3.6. Radiated Emissions.....	108
4. ANTENNA APPLICATION.....	125
4.1. Antenna requirement.....	125
4.2. Result.....	125
5. PHOTOGRAPH.....	127
5.1. Photo of Radiation Emission Test.....	127
APPENDIX I (EXTERNAL PHOTOS).....	128
APPENDIX II (INTERNAL PHOTOS).....	131

TEST REPORT

Applicant : Shenzhen Bominwell Robotics Co., Ltd.
Manufacturer : Shenzhen Bominwell Robotics Co., Ltd.
EUT : Peek Relay
Model No. : PERE
Serial No. : N.A.
Trade Mark : Bominwell
Rating : DC 3.6V, 300mA

Measurement Procedure Used:
FCC Part15 Subpart C 2015, Paragraph 15.247

The device described above is tested by Shenzhen Anbotek Compliance Laboratory Limited to determine the maximum emission levels emanating from the device and the severe levels of the device can endure and its performance criterion. The measurement results are contained in this test report and Shenzhen Anbotek Compliance Laboratory Limited is assumed full of responsibility for the accuracy and completeness of these measurements. Also, this report shows that the EUT (Equipment Under Test) is technically compliant with the FCC Part 15 Subpart C requirements.

This report applies to above tested sample only and shall not be reproduced in part without written approval of Shenzhen Anbotek Compliance Laboratory Limited.

Date of Test : Jun. 02~ 17, 2016

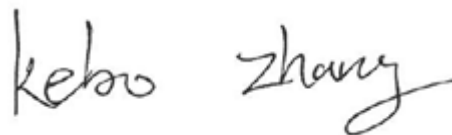
Prepared by : 
(Tested Engineer / Kebo Zhang)

Reviewer : 
(Project Manager / Amy Ding)

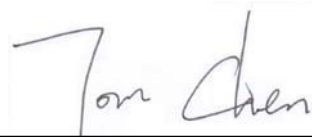
Approved & Authorized Signer : 
(Manager / Tom Chen)

1. GENERAL INFORMATION

1.1. Description of Device (EUT)

EUT : Peek Relay

Model Number : PERE

Test Power Supply : DC 3.6V Battery Inside

RF Transmission : 2412MHz~2462MHz (802.11b/802.11g/802.11n(HT20))
Frequency : 2422MHz~2452MHz (802.11n(HT40))

Channels : 11 For (802.11b/802.11g/802.11n(HT20))
7 For (802.11n(HT40))

Modulation : 802.11b CCK; 802.11g OFDM; 802.11n MCS

Antenna Gain: : 2 dBi for WiFi (ANT A, ANT B)

Applicant : Shenzhen Bominwell Robotics Co., Ltd.
Address : JK Units, 5F, Building 7, Baoneng Sci&Tech Park, Longhua Dist.,
Shenzhen, China

Manufacturer : Shenzhen Bominwell Robotics Co., Ltd.
Address : JK Units, 5F, Building 7, Baoneng Sci&Tech Park, Longhua Dist.,
Shenzhen, China

Factory : Shenzhen Bominwell Robotics Co., Ltd.
Address : JK Units, 5F, Building 7, Baoneng Sci&Tech Park, Longhua Dist.,
Shenzhen, China

Date of receipt : Jun. 02, 2016

Date of Test : Jun. 02~ 17, 2016

1.2. Auxiliary Equipment Used during Test

N/A

1.3. Description of Test Facility

The test facility is recognized, certified, or accredited by the following organizations:

FCC-Registration No.: 752021

Shenzhen Anbotek Compliance Laboratory Limited, EMC Laboratory has been registered and fully described in a report filed with the (FCC) Federal Communications Commission. The acceptance letter from the FCC is maintained in our files. Registration 752021, July 06, 2016.

IC-Registration No.: 8058A-1

Shenzhen Anbotek Compliance Laboratory Limited., EMC Laboratory has been registered and fully described in a report filed with the (IC) Industry Canada. The acceptance letter from the IC is maintained in our files. Registration 8058A-1, Jun. 13, 2016.

Test Location

All Emissions tests were performed at
Shenzhen Anbotek Compliance Laboratory Limited. at 1/F., Building 1, SEC
Industrial Park, No.0409 Qianhai Road, Nanshan District, Shenzhen, Guangdong,
China

1.4. Measurement Uncertainty

Radiation Uncertainty : Ur = 4.1 dB (Horizontal)
Ur = 4.3 dB (Vertical)

Conduction Uncertainty : Uc = 3.4dB

2. TEST METHODOLOGY

The tests documented in this report were performed in accordance with ANSI C63.10: 2013 and FCC Part 15, Paragraph 15.247.

2.1. Summary of Test Results

The EUT has been tested according to the following specifications:

Standard	Test Type	Result	Notes
FCC Part 15, Paragraph 15.107, 15.207	Conducted Emission Test	-	N/A
FCC Part 15, Paragraph 15.247(b)(1)	Maximum Output Power	PASS	Complies
FCC Part 15, Paragraph 15.247(a)(2)	6dB Bandwidth	PASS	Complies
FCC Part 15, Paragraph 15.247(c)	100kHz Bandwidth of Frequency Band Edges	PASS	Complies
FCC Part 15, Paragraph 15.209(a)(f)	Spurious Emission	PASS	Complies
FCC Part 15, Paragraph 15.247(a)(1)	Frequency Separation	-	N/A
FCC Part 15, Paragraph 15.247(a)(1)(iii)	Number of Hopping Frequency	-	N/A
FCC Part 15, Paragraph 15.247(a)(1)(iii)	Time of Occupancy	-	N/A
FCC Part 15, Paragraph 15.247(c)	Peak Power Density	PASS	Complies

Note: This product is low voltage products. It is using the battery as a power source.

2.2. Description of Test Modes

The EUT has been tested under operating condition.

Software used to control the EUT for staying in continuous transmitting and receiving mode is programmed.

IEEE802.11b: Channel 1(2412MHz), Channel 6(2437MHz) and Channel 11(2462MHz) with 1 Mbps lowest data rate (worst case) are chosen for the final testing.

IEEE802.11g: Channel 1(2412MHz), Channel 6(2437MHz) and Channel 11(2462MHz) with 6 Mbps lowest data rate (the worst case) are chosen for the final testing.

IEEE802.11n (HT20): Channel 1(2412MHz), Channel 6(2437MHz) and Channel 11(2462MHz) with MCS 0 Mbps lowest data rate (the worst case) are chosen for the final testing.

IEEE802.11n (HT40): Channel 3(2422MHz), Channel 6(2437MHz) and Channel 9(2452MHz) with MCS 0 Mbps lowest data rate (the worst case) are chosen for the final testing.

2.3. List of channels:

√ - available

X - tested

Number	Frequency(MHz)		802.11 b/g/n (HT20)	802.11 b/g/n (HT40)
1	2412	√	X	
2	2417	√		
3	2422	√		X
4	2427	√		
5	2432	√		
6	2437	√	X	X
7	2442	√		
8	2447	√		
9	2452	√		X
10	2457	√		
11	2462	√	X	

Anbotek

3. FCC Part 15.247 Requirements for DSSS & OFDM Modulation

3.1 Test Setup

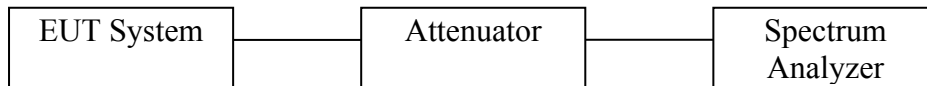

3.2 6dB Bandwidth

a. Limit

For the direct sequence systems, the minimum 6dB bandwidth shall be at least 500kHz.

b. Test Procedure

1. Place the EUT on the table and set it in the transmitting mode.
2. Remove the antenna from the EUT and then connect a low loss RF cable from the antenna port to the spectrum analyzer.
3. Set the spectrum analyzer as:
RBW = 100kHz, VBW $\geq 3 \times$ RBW = 300kHz,
Detector= Peak
Trace mode= Max hold.
Sweep- auto couple.
4. Mark the peak frequency and -6 dB (upper and lower) frequency.
5. Repeat until all the rest channels are investigated.

20dB Bandwidth:

C63.10

Occupied Bandwidth (OBW=20dB Bandwidth)

1. Set RBW=1%~5% OBW
2. Set the VBW $\geq 3 \times$ RBW
3. Set the span range between 2 times and 5 times of the OBW
4. Sweep Time= Auto
Detector= Peak
Trace= Max hold
5. Once the reference level is established, the equipment is conditioned with typical modulating signals to produce the worst case (i.e. the widest) bandwidth. Unless otherwise specified for an unlicensed wireless device, measure the bandwidth at the -20 dB levels with respect to the reference level.

c. Test Setup See 3.1

d. Test Equipment

Item	Equipment	Manufacturer	Model No.	Serial No.	Last Cal.	Cal. Interval
1.	Spectrum Analysis	Agilent	E4407B	US39390582	Apr. 17, 2016	1 Year
2.	Preamplifier	Instruments corporation	EMC011830	980100	Apr. 17, 2016	1 Year
3.	EMI Test Receiver	Rohde & Schwarz	ESPI	101604	Apr. 17, 2016	1 Year
4.	Double Ridged Horn Antenna	Instruments corporation	GTH-0118	351600	Apr. 20, 2016	1 Year
5.	Bilog Broadband Antenna	Schwarzbeck	VULB9163	VULB 9163-289	Apr. 20, 2016	1 Year
6.	Pre-amplifier	SONOMA	310N	186860	Apr. 17, 2016	1 Year
7.	EMI Test Software EZ-EMC	SHURPLE	N/A	N/A	N/A	N/A
8	Power Sensor	DAER	RPR3006W	15I00041SN046	Jun 30, 2015	1 Year
9	MXA Spectrum Analysis	Agilent	N9020A	MY51170037	Jun 30, 2015	1 Year
10	MXG RF Vector Signal Generator	Agilent	N5182A	MY48180656	Jun 30, 2015	1 Year
11	Signal Generator	Agilent	E4421B	MY41000743	Jun 30, 2015	1 Year
12	DC Power supply	IV	IV-8080	YQSB0096	Jun 30, 2015	1 Year
13	TEMP&HUMI PROGRAMMABLE CHAMBER	Bell Group	BE-THK-150M8	SE-0137	Mar 16, 2016	1 Year

e. Test Results

Pass.

f. Test Data
6dB Bandwidth

ANT A

Test mode: IEEE 802.11b

Channel	Frequency (MHz)	Bandwidth (MHz)	Limit (kHz)	Results
Low	2412	10.03	>500	Pass
Mid	2437	10.02		Pass
High	2462	9.558		Pass

Test mode: IEEE 802.11g

Channel	Frequency (MHz)	Bandwidth (MHz)	Limit (kHz)	Results
Low	2412	15.44	>500	Pass
Mid	2437	15.44		Pass
High	2462	15.67		Pass

Test mode: IEEE 802.11n (HT20)

Channel	Frequency (MHz)	Bandwidth (MHz)	Limit (kHz)	Results
Low	2412	15.91	>500	Pass
Mid	2437	16.91		Pass
High	2462	15.14		Pass

Test mode: IEEE 802.11n (HT40)

Channel	Frequency (MHz)	Bandwidth (MHz)	Limit (kHz)	Results
Low	2422	35.40	>500	Pass
Mid	2437	35.17		Pass
High	2452	35.35		Pass

Test Plots See the following page.

ANT B

Test mode: IEEE 802.11b

Channel	Frequency (MHz)	Bandwidth (MHz)	Limit (kHz)	Results
Low	2412	9.085		Pass
Mid	2437	10.03	>500	Pass
High	2462	9.566		Pass

Test mode: IEEE 802.11g

Channel	Frequency (MHz)	Bandwidth (MHz)	Limit (kHz)	Results
Low	2412	15.46		Pass
Mid	2437	15.32	>500	Pass
High	2462	15.13		Pass

Test mode: IEEE 802.11n (HT20)

Channel	Frequency (MHz)	Bandwidth (MHz)	Limit (kHz)	Results
Low	2412	15.96		Pass
Mid	2437	16.07	>500	Pass
High	2462	15.11		Pass

Test mode: IEEE 802.11n (HT40)

Channel	Frequency (MHz)	Bandwidth (MHz)	Limit (kHz)	Results
Low	2422	35.47		Pass
Mid	2437	35.33	>500	Pass
High	2452	35.17		Pass

Test Plots See the following page.

ANT A

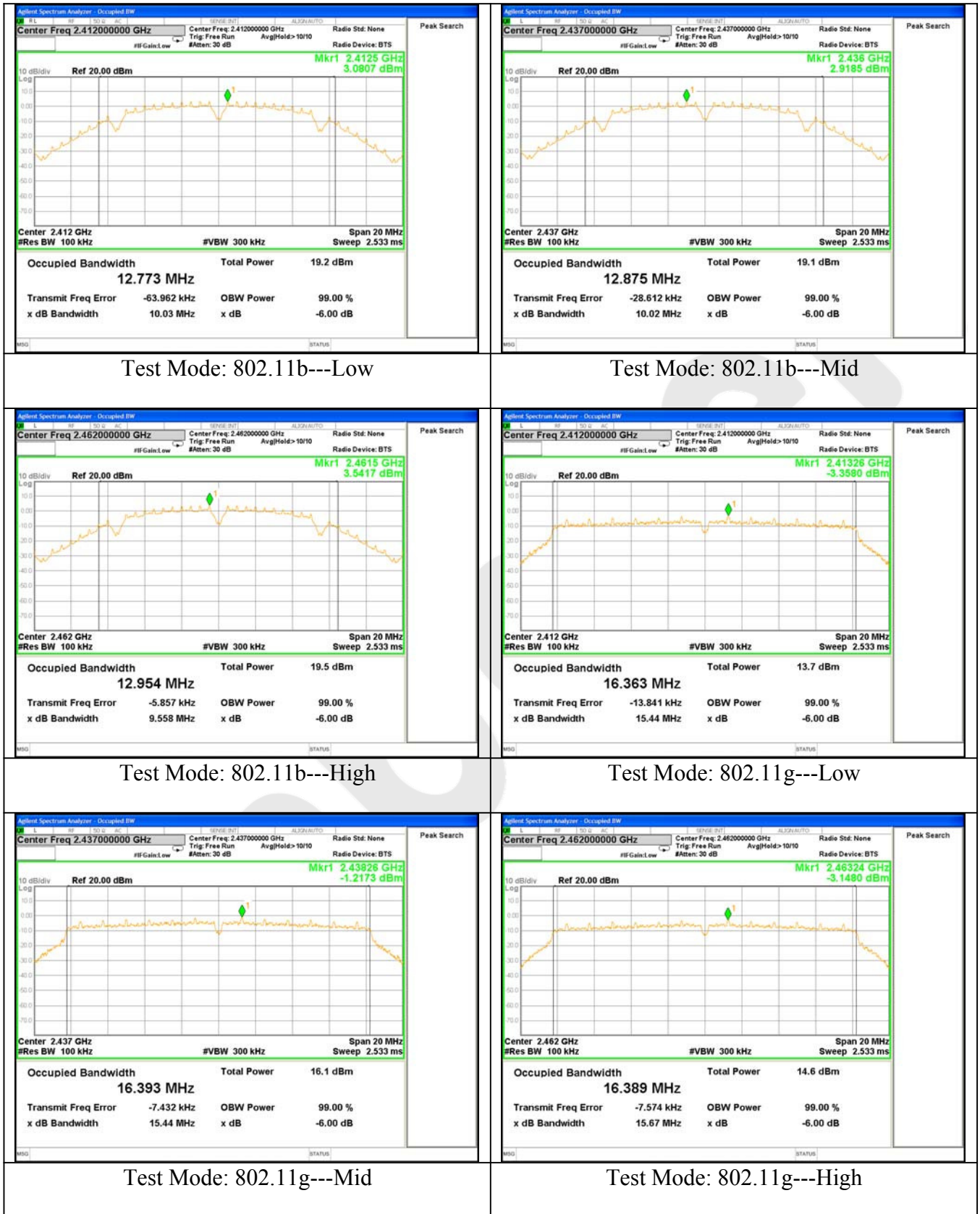

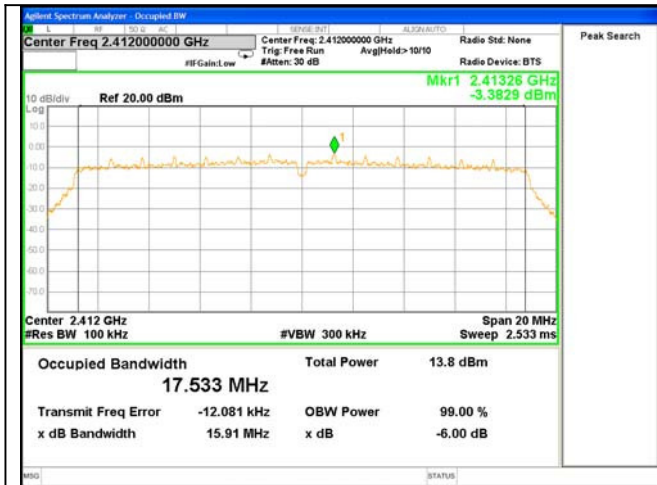

Test Mode: 802.11n20---Low

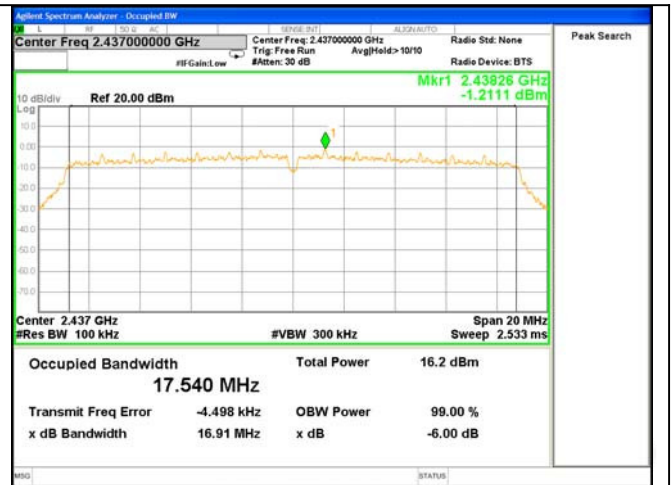

Test Mode: 802.11n20---Mid

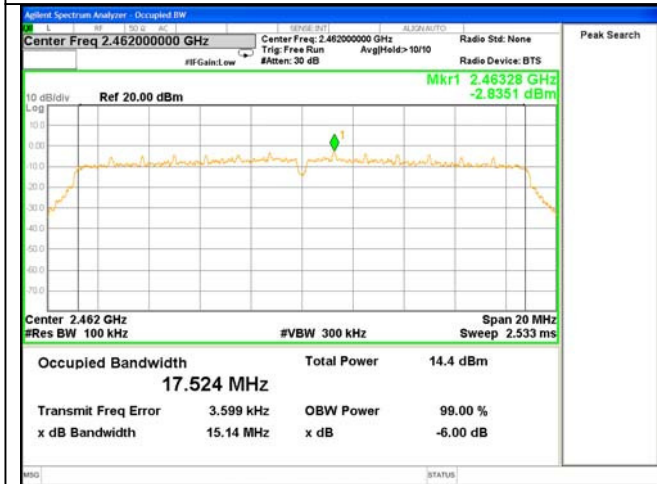

Test Mode: 802.11n20---High

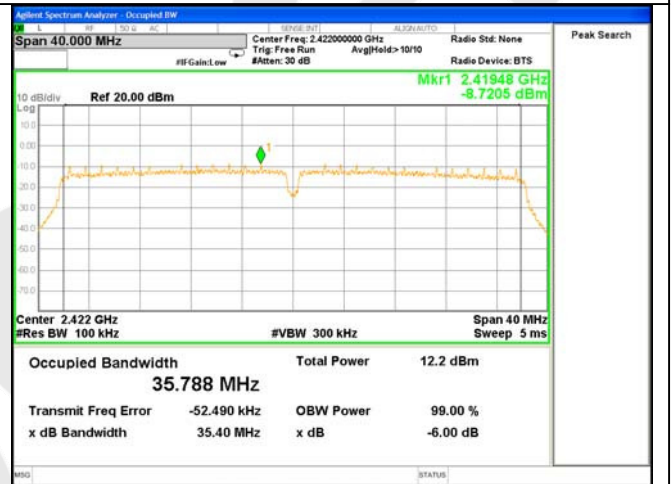

Test Mode: 802.11n40---Low

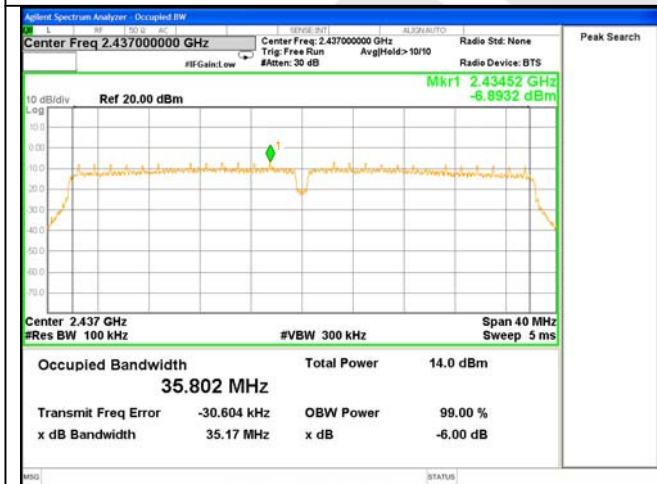

Test Mode: 802.11n40---Mid

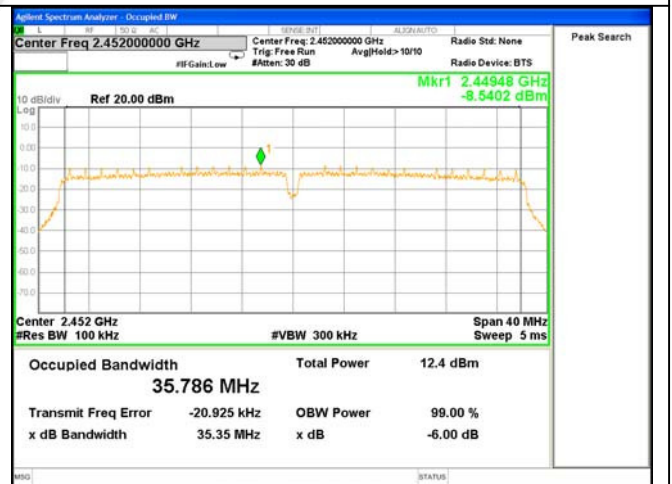

Test Mode: 802.11n40---High

ANT B

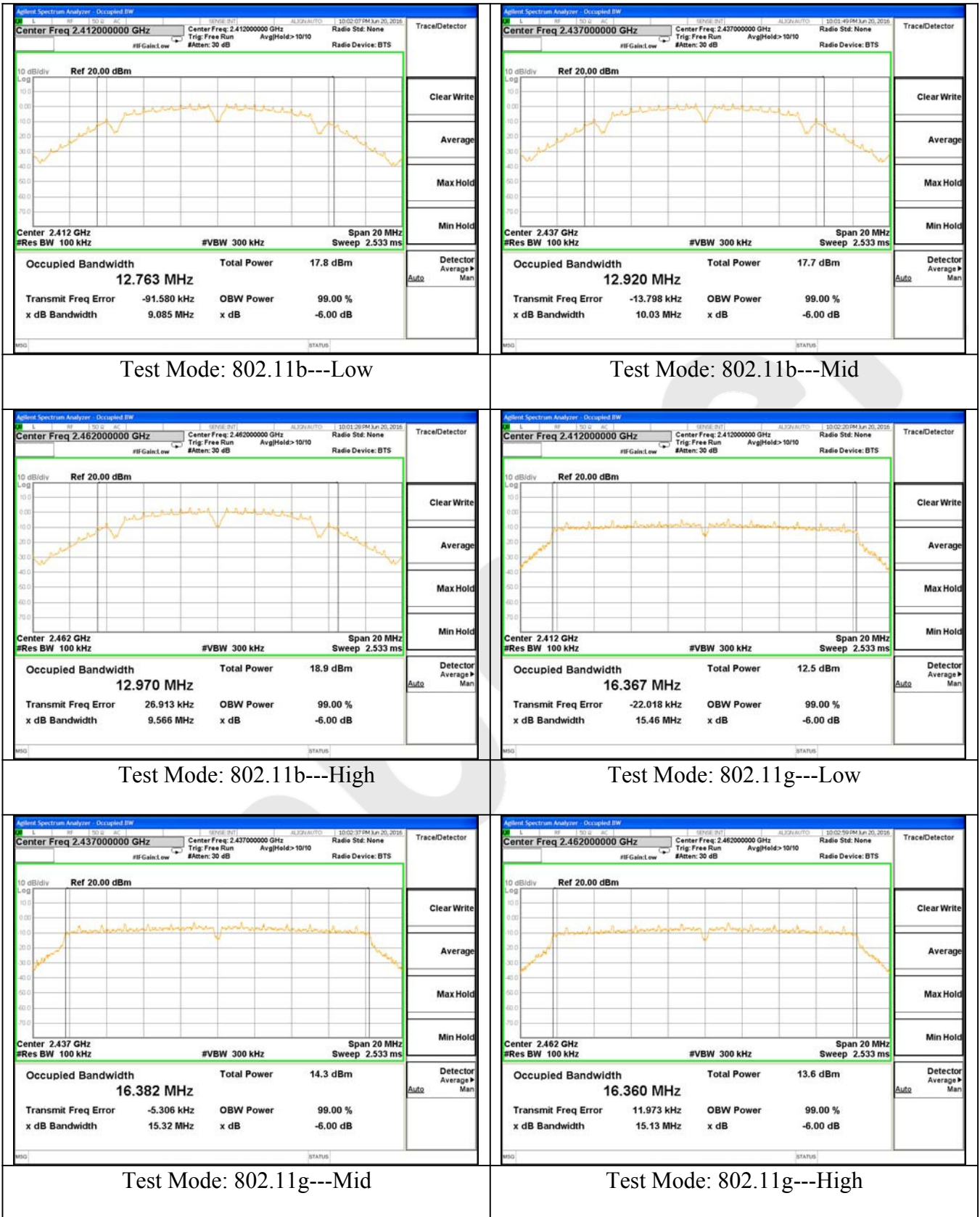

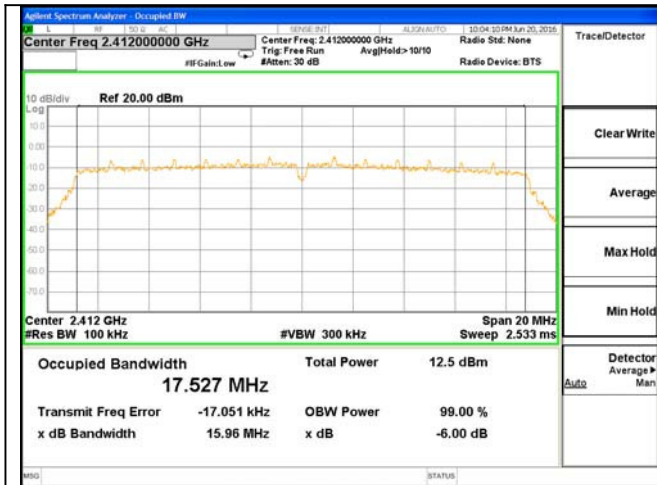

Test Mode: 802.11n20---Low

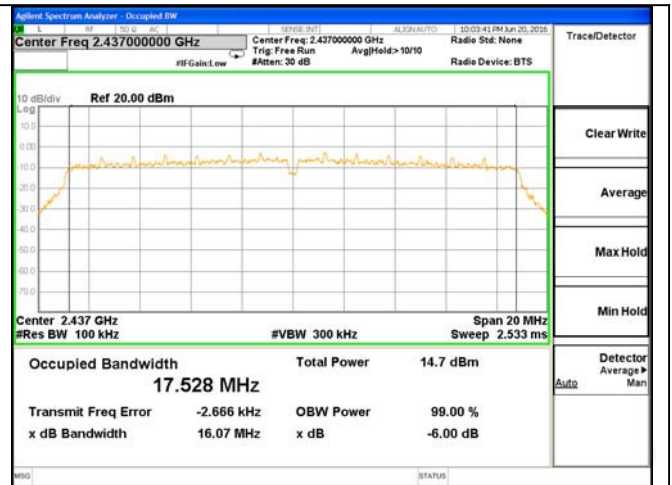

Test Mode: 802.11n20---Mid

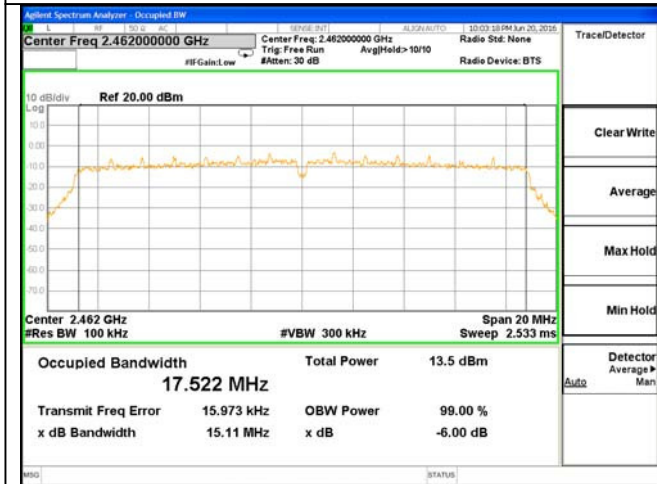

Test Mode: 802.11n20---High

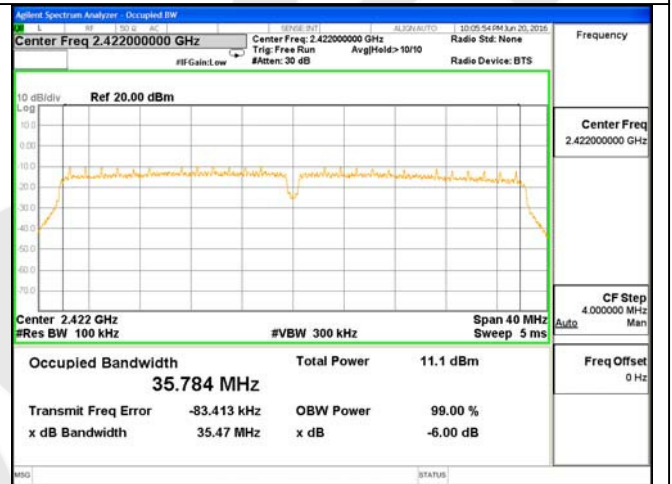

Test Mode: 802.11n40---Low

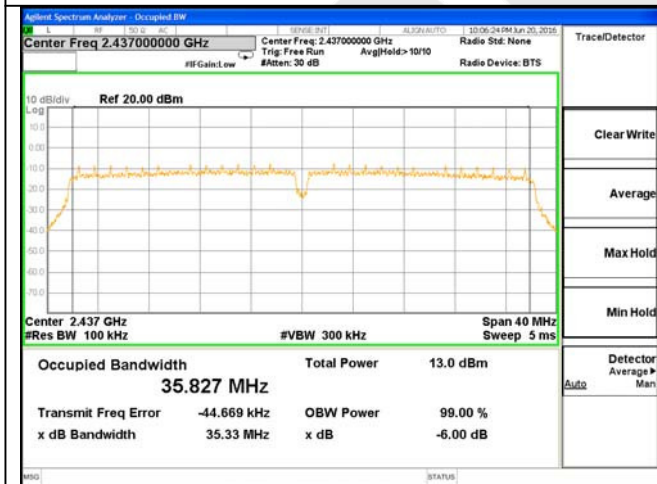

Test Mode: 802.11n40---Mid

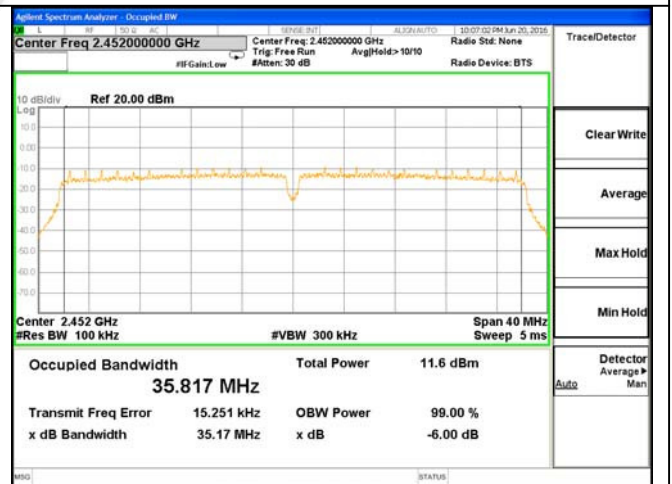

Test Mode: 802.11n40---High

20dB Bandwidth

ANT A

Test mode: IEEE 802.11b

Channel	Frequency (MHz)	Bandwidth (MHz)	Results
Low	2412	14.73	Pass
Mid	2437	15.11	Pass
High	2462	15.20	Pass

Test mode: IEEE 802.11g

Channel	Frequency (MHz)	Bandwidth (MHz)	Results
Low	2412	18.90	Pass
Mid	2437	18.82	Pass
High	2462	18.73	Pass

Test mode: IEEE 802.11n (HT20)

Channel	Frequency (MHz)	Bandwidth (MHz)	Results
Low	2412	19.29	Pass
Mid	2437	19.32	Pass
High	2462	19.23	Pass

Test mode: IEEE 802.11n (HT40)

Channel	Frequency (MHz)	Bandwidth (MHz)	Results
Low	2422	38.11	Pass
Mid	2437	38.10	Pass
High	2452	38.11	Pass

Test Plots See the following page.

ANT B

Test mode: IEEE 802.11b

Channel	Frequency (MHz)	Bandwidth (MHz)	Results
Low	2412	14.72	Pass
Mid	2437	15.09	Pass
High	2462	15.15	Pass

Test mode: IEEE 802.11g

Channel	Frequency (MHz)	Bandwidth (MHz)	Results
Low	2412	18.57	Pass
Mid	2437	18.84	Pass
High	2462	18.60	Pass

Test mode: IEEE 802.11n (HT20)

Channel	Frequency (MHz)	Bandwidth (MHz)	Results
Low	2412	19.07	Pass
Mid	2437	19.23	Pass
High	2462	19.17	Pass

Test mode: IEEE 802.11n (HT40)

Channel	Frequency (MHz)	Bandwidth (MHz)	Results
Low	2422	38.99	Pass
Mid	2437	39.30	Pass
High	2452	39.23	Pass

Test Plots See the following page.

ANT A

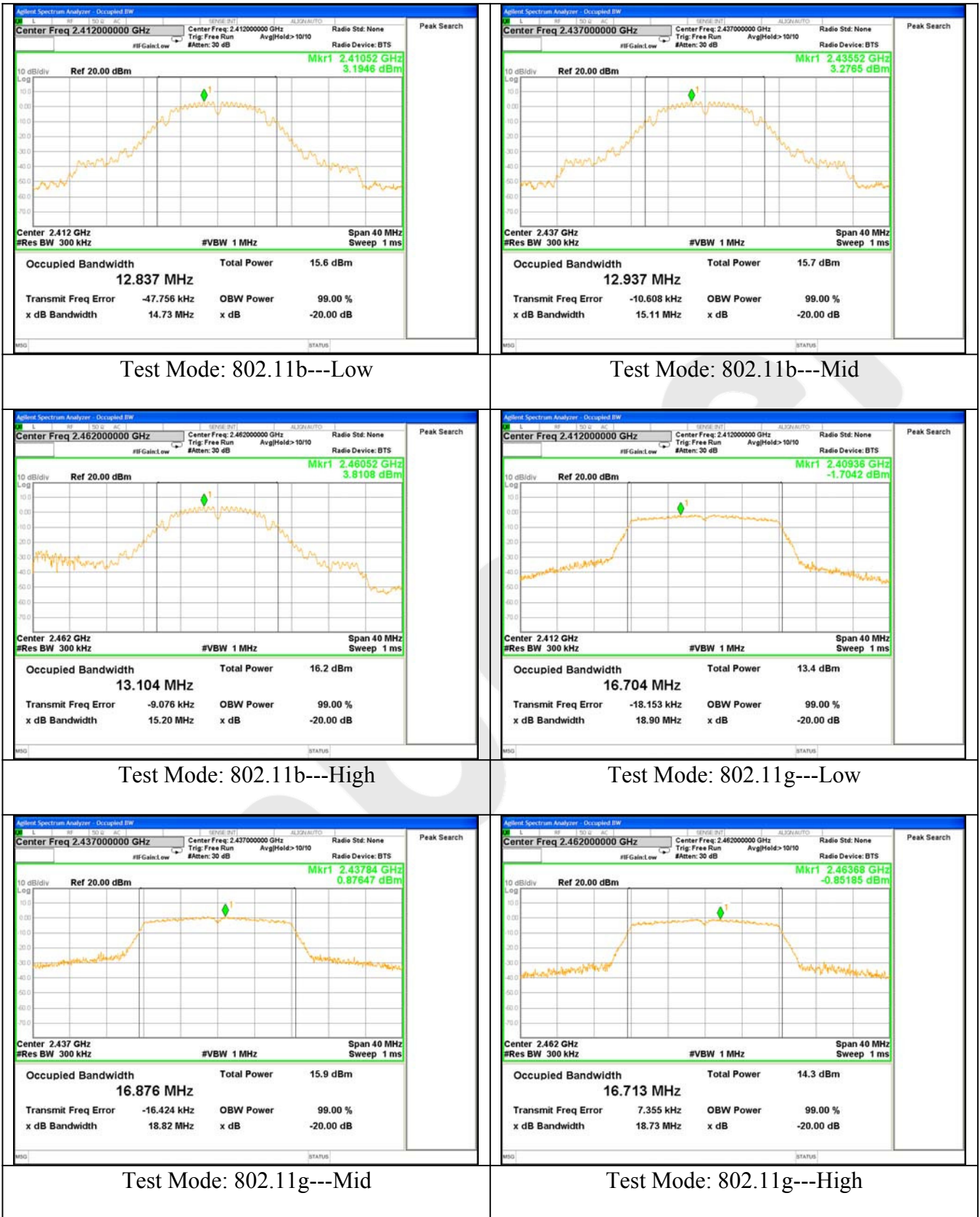

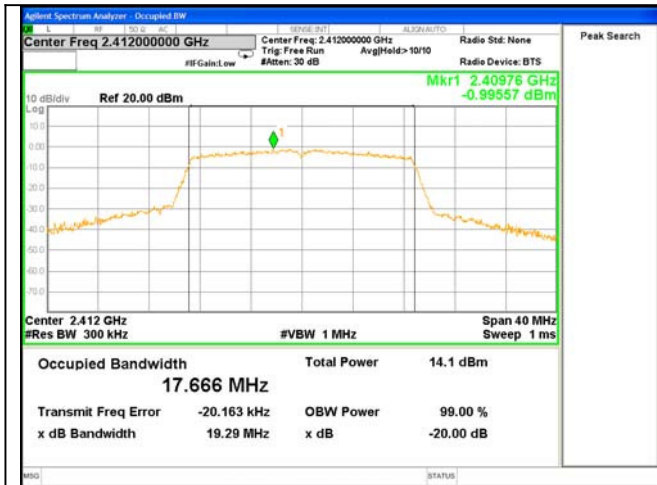

Test Mode: 802.11n20---Low

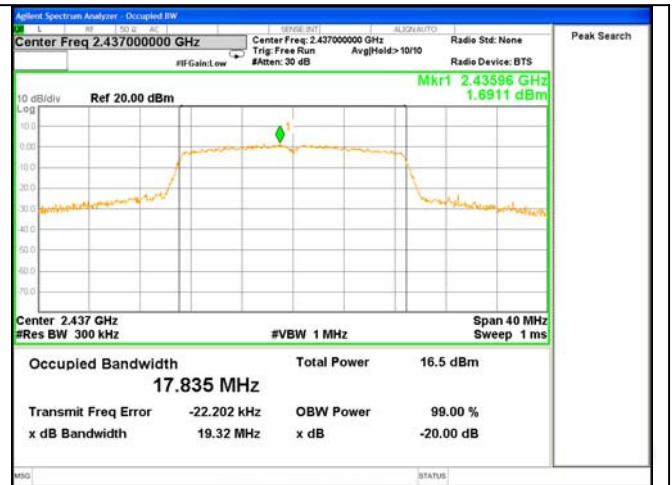

Test Mode: 802.11n20---Mid

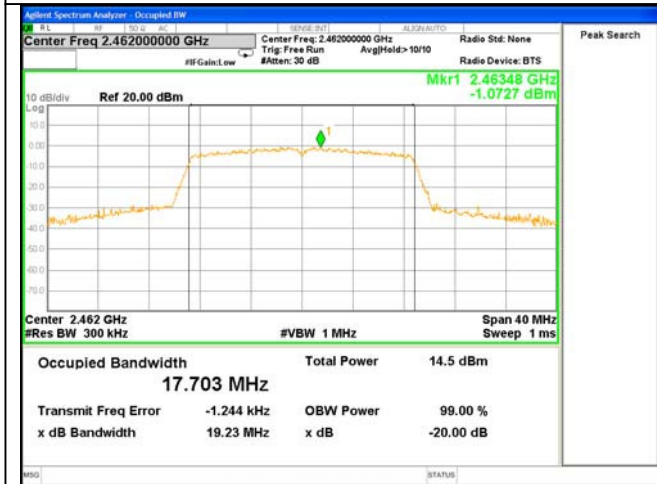

Test Mode: 802.11n20---High

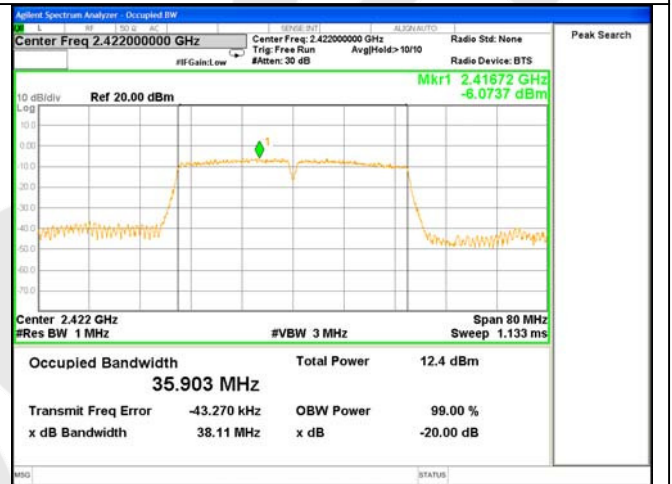

Test Mode: 802.11n40---Low

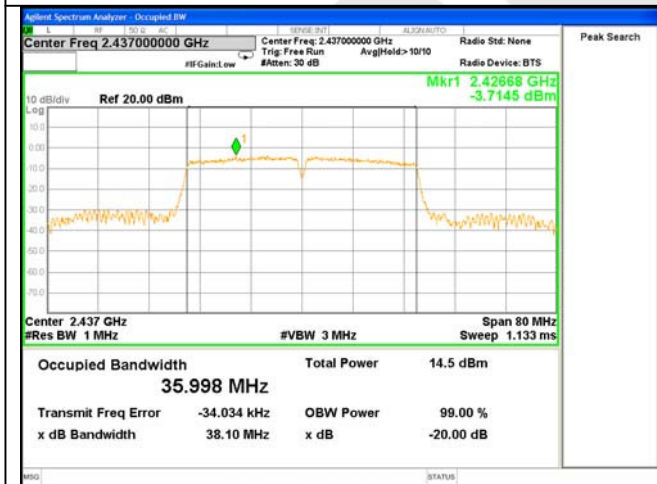

Test Mode: 802.11n40---Mid

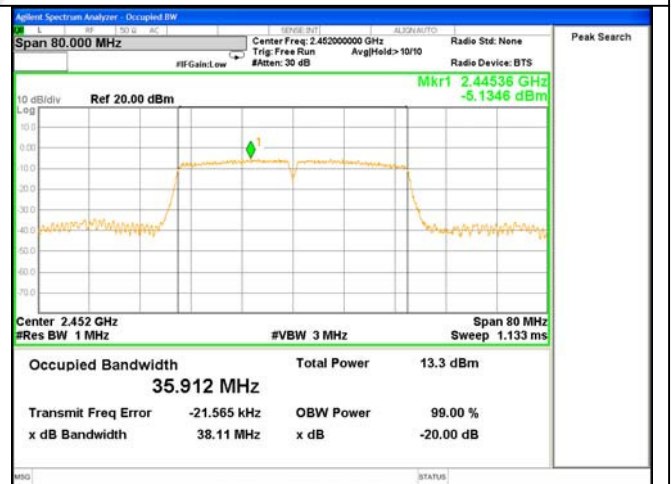

Test Mode: 802.11n40---High

ANT B



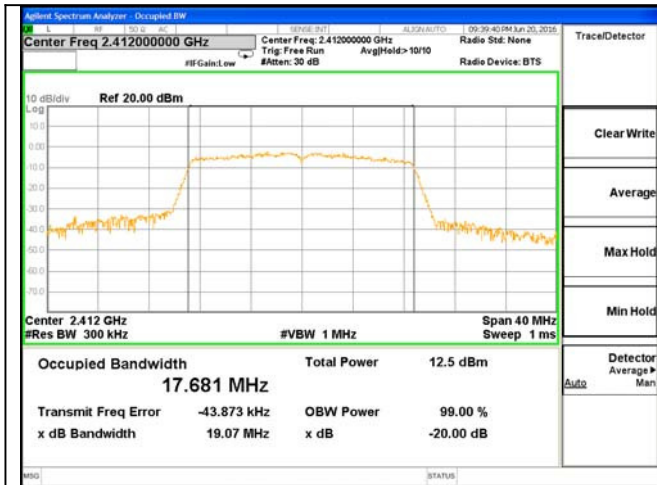

Test Mode: 802.11n20---Low

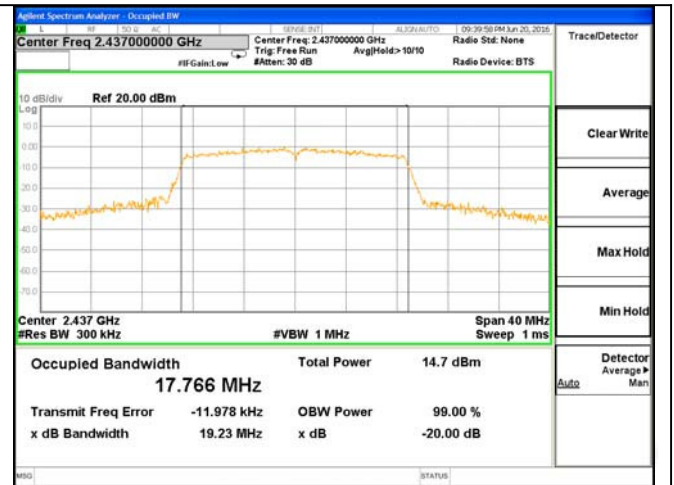

Test Mode: 802.11n20---Mid

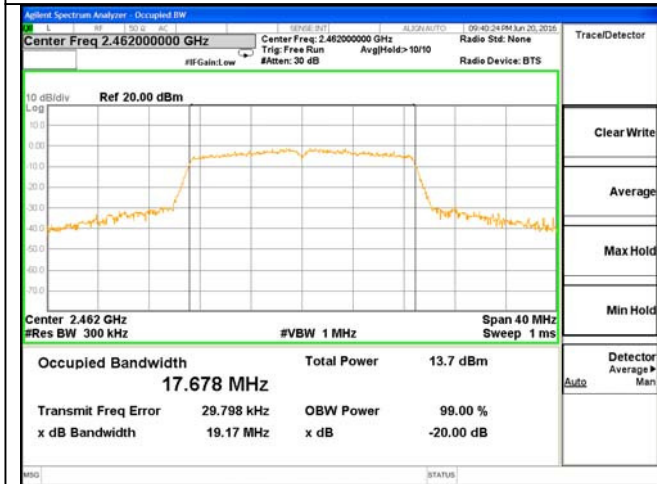

Test Mode: 802.11n20---High

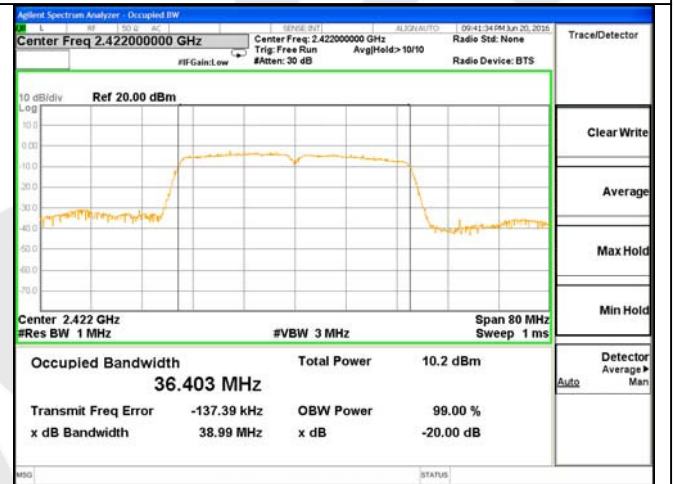

Test Mode: 802.11n40---Low

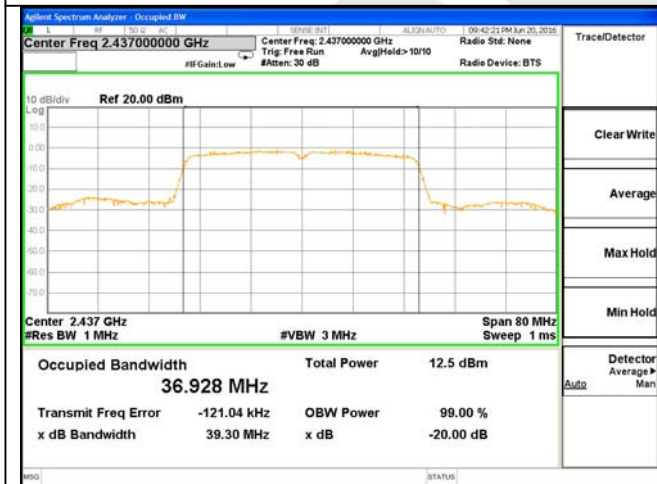

Test Mode: 802.11n40---Mid

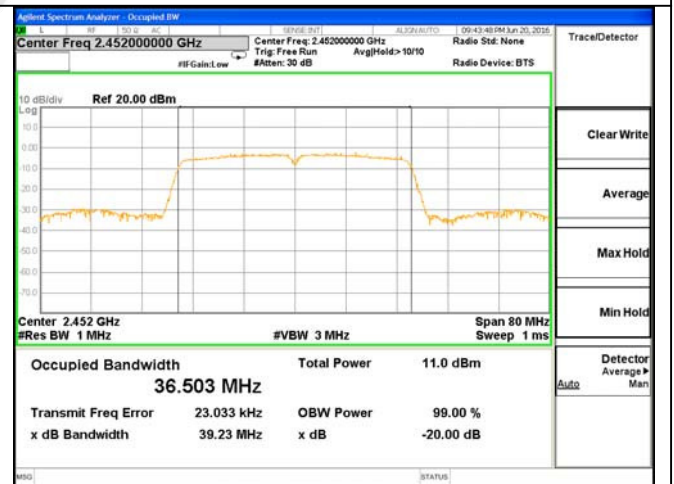

Test Mode: 802.11n40---High

3.3. Maximum Output Power Test

a. Limit

The maximum output power of the intentional radiator shall not exceed the following:

1. For systems using digital modulation in the bands of 902-928 MHz, 2400-2483.5 MHz, and 5725-5850 MHz: 1 watt (30dBm).
2. Except as shown in paragraphs (b)(3) (i), (ii) and (iii) of this section, if transmitting antenna of directional gain greater than 6 dBi are used the peak output power from the intentional radiator shall be reduced below the stated values in paragraphs (b)(1) or (b)(2) of this section, as appropriate, by the amount in dB that the directional gain of the antenna exceeds 6 dBi.

b. Configuration of Measurement

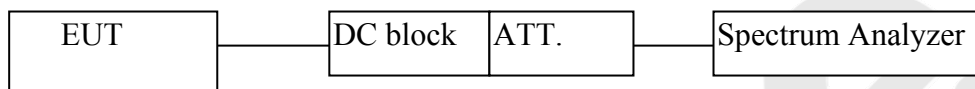

c. Data Rates

IEEE802.11b: Channel 1(2412MHz), Channel 6(2437MHz) and Channel 11(2462MHz) with 1 Mbps data rate (worst case) are chosen for the final testing.

IEEE802.11g: Channel 1(2412MHz), Channel 6(2437MHz) and Channel 11(2462MHz) with 6 Mbps data rate (the worst case) are chosen for the final testing.

IEEE802.11n (HT20): Channel 1(2412MHz), Channel 6(2437MHz) and Channel 11(2462MHz) with 6.5Mbps data rate (the worst case) are chosen for the final testing.

IEEE802.11n (HT40): Channel 3(2422MHz), Channel 6(2437MHz) and Channel 9(2452MHz) with 13.5Mbps data rate (the worst case) are chosen for the final testing.

d. Test Procedure

This test was according the kDB 558074 D01 DTS Meas Guidance v03r05 9.1.1:

1. Set span to at least 1.5 times the OBW.
2. Set the RBW = 1~5% of the OBW, not to exceed 1MHz.
3. Set VBW ≥ 3 * RBW.
4. Detector = Average.
5. Sweep time = auto couple.
6. Trace mode = max hold.
7. Allow trace to fully stabilize.

e. Test Equipment

Same as the equipment listed in 3.2.

f. Test Results

Pass.

g. Test Data

Antenna A Gain= 2 dBi

Antenna B Gain= 2 dBi

Array Gain= 5.01 dBi= $G_{ANT}+10*\log(N_{ANT})$ dBi

ANT A

Test mode: IEEE 802.11b

Channel	Frequency (MHz)	Maximum transmit power (dBm)	Limit		Result
			(dBm)	(watts)	
Low	2412	16.45	30	1	Pass
Mid	2437	16.33			Pass
High	2462	16.60			Pass

Test mode: IEEE 802.11g

Channel	Frequency (MHz)	Maximum transmit power (dBm)	Limit		Result
			(dBm)	(watts)	
Low	2412	14.31	30	1	Pass
Mid	2437	16.38			Pass
High	2462	14.97			Pass

Test mode: IEEE 802.11n (HT20)

Channel	Frequency (MHz)	Maximum transmit power (dBm)	Limit		Result
			(dBm)	(watts)	
Low	2412	14.52	30	1	Pass
Mid	2437	14.54			Pass
High	2462	13.34			Pass

Test mode: IEEE 802.11n (HT40)

Channel	Frequency (MHz)	Maximum transmit power (dBm)	Limit		Result
			(dBm)	(watts)	
Low	2422	9.61	30	1	Pass
Mid	2437	11.96			Pass
High	2452	10.22			Pass

ANT B

Test mode: IEEE 802.11b

Channel	Frequency (MHz)	Maximum transmit power (dBm)	Limit		Result
			(dBm)	(watts)	
Low	2412	14.86	30	1	Pass
Mid	2437	14.49			Pass
High	2462	15.80			Pass

Test mode: IEEE 802.11g

Channel	Frequency (MHz)	Maximum transmit power (dBm)	Limit		Result
			(dBm)	(watts)	
Low	2412	12.89	30	1	Pass
Mid	2437	14.51			Pass
High	2462	13.89			Pass

Test mode: IEEE 802.11n (HT20)

Channel	Frequency (MHz)	Maximum transmit power (dBm)	Limit		Result
			(dBm)	(watts)	
Low	2412	12.65	30	1	Pass
Mid	2437	14.57			Pass
High	2462	13.77			Pass

Test mode: IEEE 802.11n (HT40)

Channel	Frequency (MHz)	Maximum transmit power (dBm)	Limit		Result
			(dBm)	(watts)	
Low	2422	10.21	30	1	Pass
Mid	2437	12.31			Pass
High	2452	10.96			Pass

Channel	Channel Frequency (MHz)	ANT A Output Power (dBm)	ANT B Output Power (dBm)	Data Rate (Mbps)	MIMO Output Power (dBm)	Limit (dBm)
802.11n (20M MIMO) mode						
Low	2412	14.52	12.65	MCS0	16.70	30
Middle	2437	14.54	14.57	MCS0	17.57	30
High	2462	13.34	13.77	MCS0	16.57	30
802.11n (40M MIMO) mode						
Low	2422	9.61	10.21	MCS0	12.93	30
Middle	2437	11.96	12.31	MCS0	15.15	30
High	2452	10.22	10.96	MCS0	13.62	30

ANT A

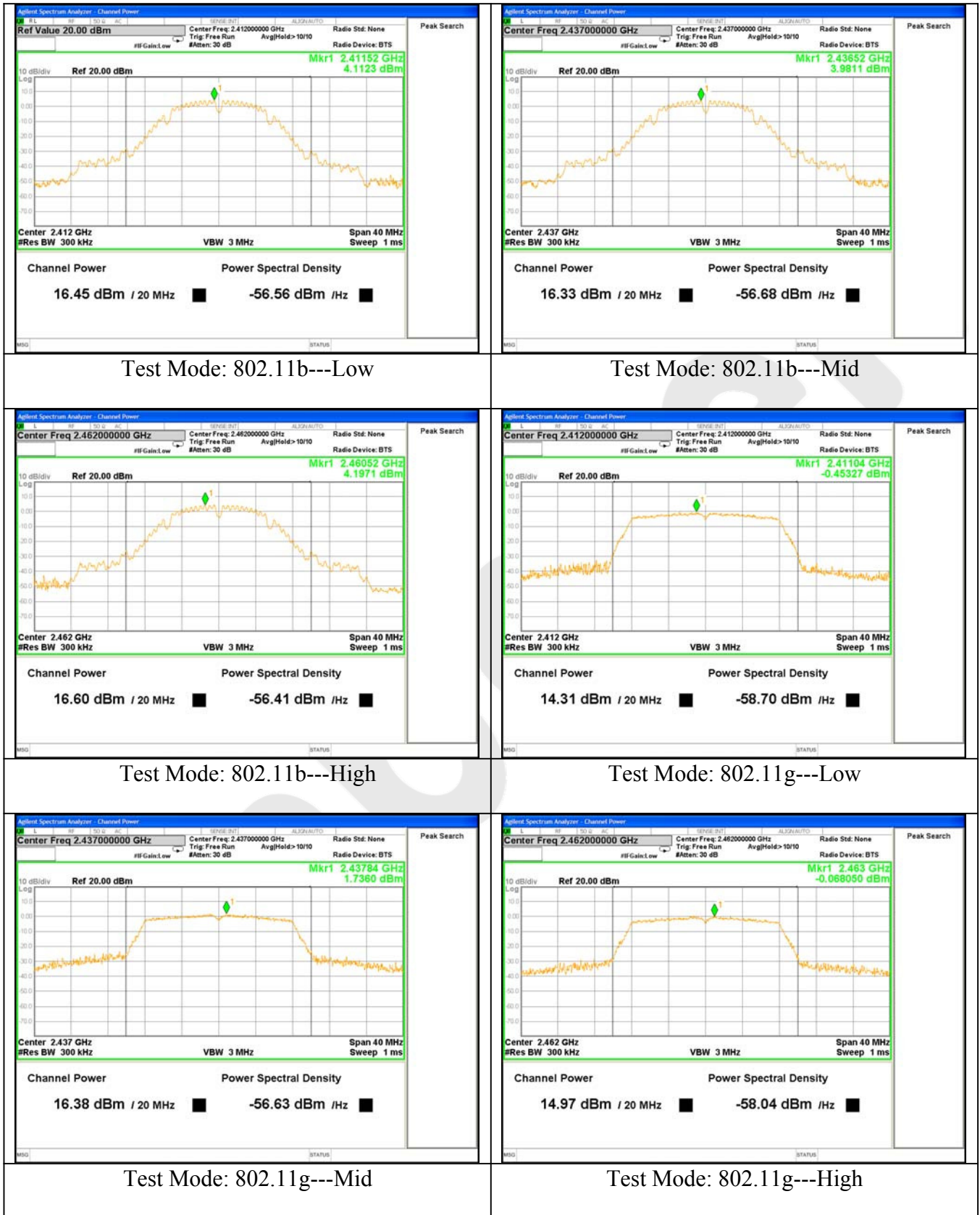

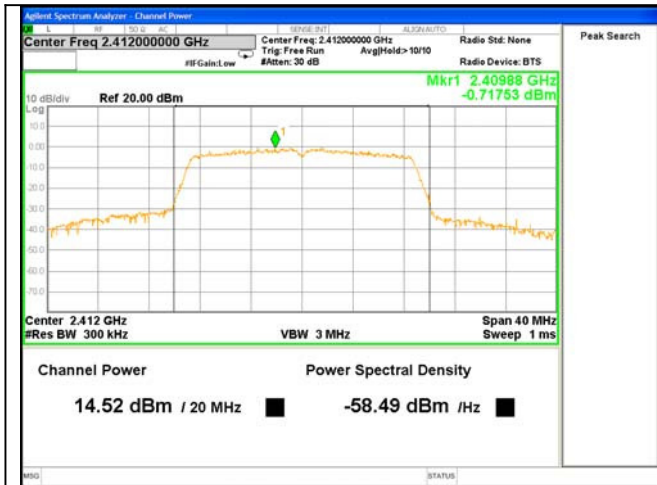

Test Mode: 802.11n20---Low

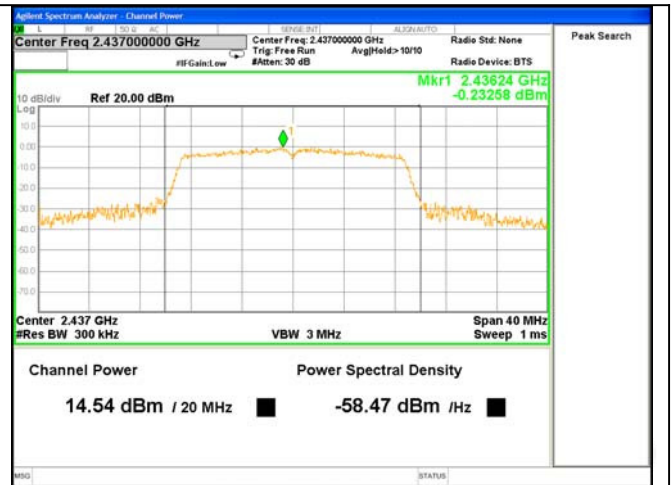

Test Mode: 802.11n20---Mid



Test Mode: 802.11n20---High



Test Mode: 802.11n40---Low

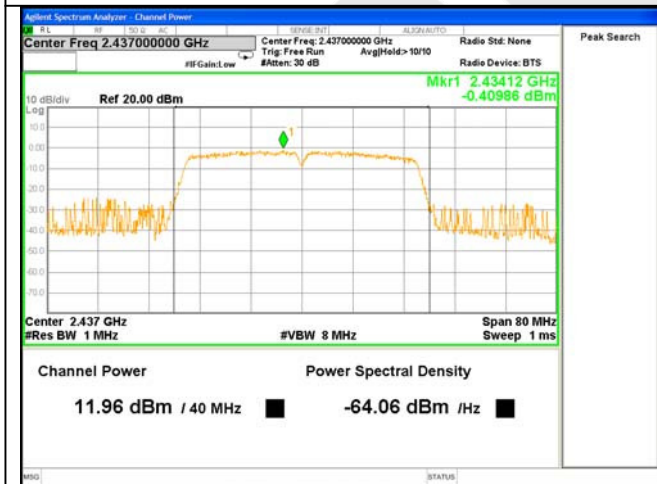

Test Mode: 802.11n40---Mid

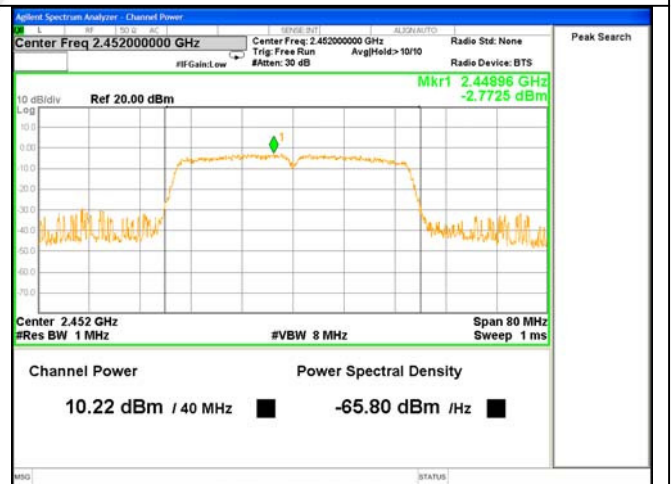

Test Mode: 802.11n40---High

ANT B





Test Mode: 802.11n20---Low

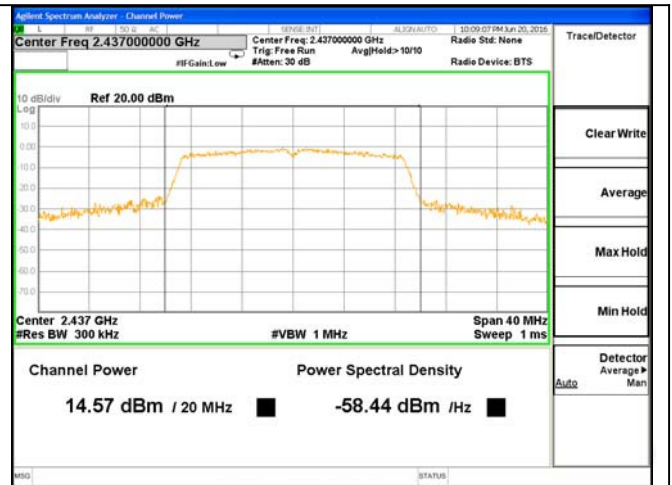

Test Mode: 802.11n20---Mid



Test Mode: 802.11n20---High

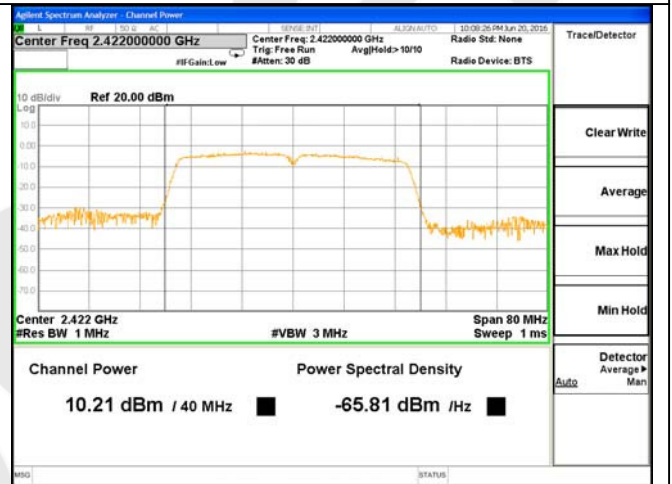

Test Mode: 802.11n40---Low

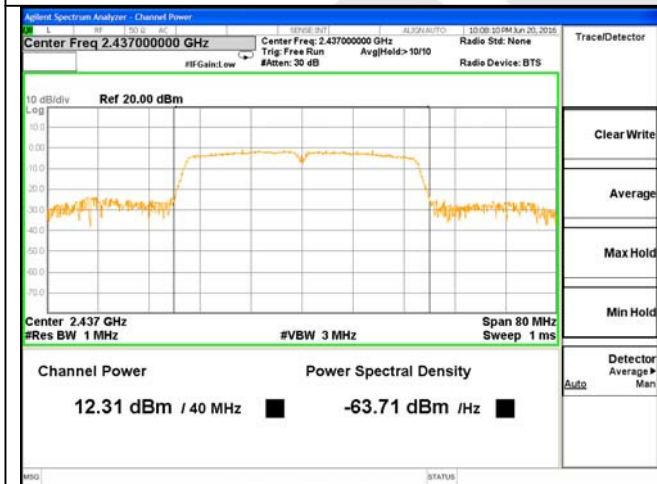

Test Mode: 802.11n40---Mid

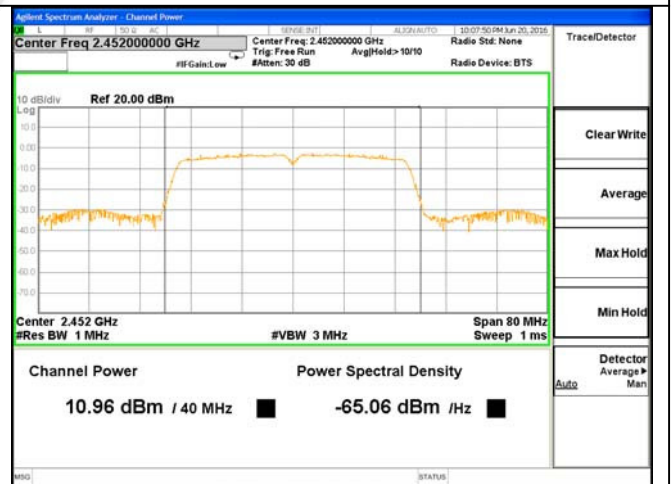

Test Mode: 802.11n40---High

3.4. Band Edges Measurement

a. Limit

According to §15.247(c), in any 100 kHz bandwidth outside the frequency bands in which the spread spectrum intentional radiator is operating, the radio frequency power that is produced by the intentional radiator shall be at least 20dB below that in the 100kHz bandwidth within the band that contains the highest level of the desired power, In addition, radiated emissions which fall in the restricted bands, as defined in §15.205(a), must also comply with the radiated emission limits specified in §15.209(a).

b. Test Procedure

1. Conducted Method:

- 1) Set RBW=100KHz, VBW=300KHz
- 2) Detector=peak
- 3) Sweep time= auto
- 4) Trace mode=max hold.

2. Radiated Method:

- 1) For below 1GHz: The EUT is placed on a turntable, which is 0.8m above the ground plane. The EUT is tested in 9*6*6 Chamber.
For above 1GHz: The EUT is placed on a turntable, which is 1.5m above the ground plane. The EUT is tested in 9*6*6 Chamber.
- 2) The turntable shall be rotated for 360 degrees to determine the position of maximum emission level.
- 3) EUT is set 3m away from the receiving antenna, which is varied from 1m to 4m to find out the highest emission.
- 4) Peak detector: RBW=1MHz, VBW=3MHz, SWT=AUTO
Average detector: RBW=1MHz, VBW=10Hz, SWT=AUTO
The EUT is tested in 9*6*6 Chamber.
- 5) Repeat the procedures until all the PEAK and AVERAGE versus POLARIZATION are measured.

30M to 1G emissions:

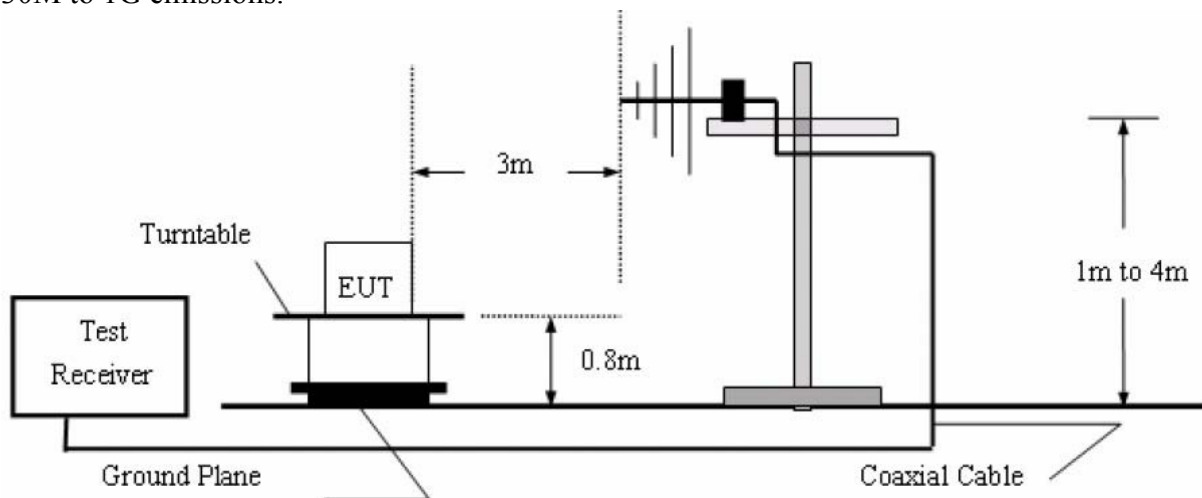

1G to 40G emissions:

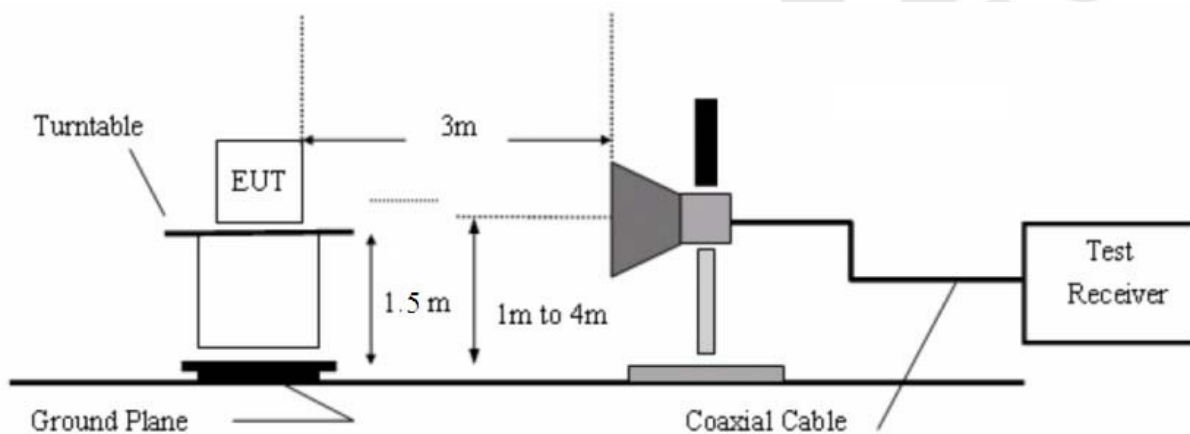

c. Test Equipment

Same as the equipment listed in 3.2.

d. Test Results

Pass.

e. Test Plots

See the following page.

ANT A

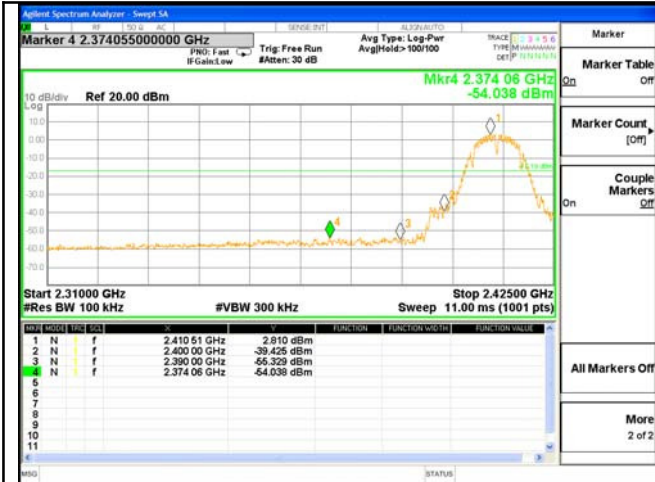

Test Mode: 802.11b---Low



Test Mode: 802.11b---High



Test Mode: 802.11g---Low



Test Mode: 802.11g---High



Test Mode: 802.11n20---Low



Test Mode: 802.11n20---High

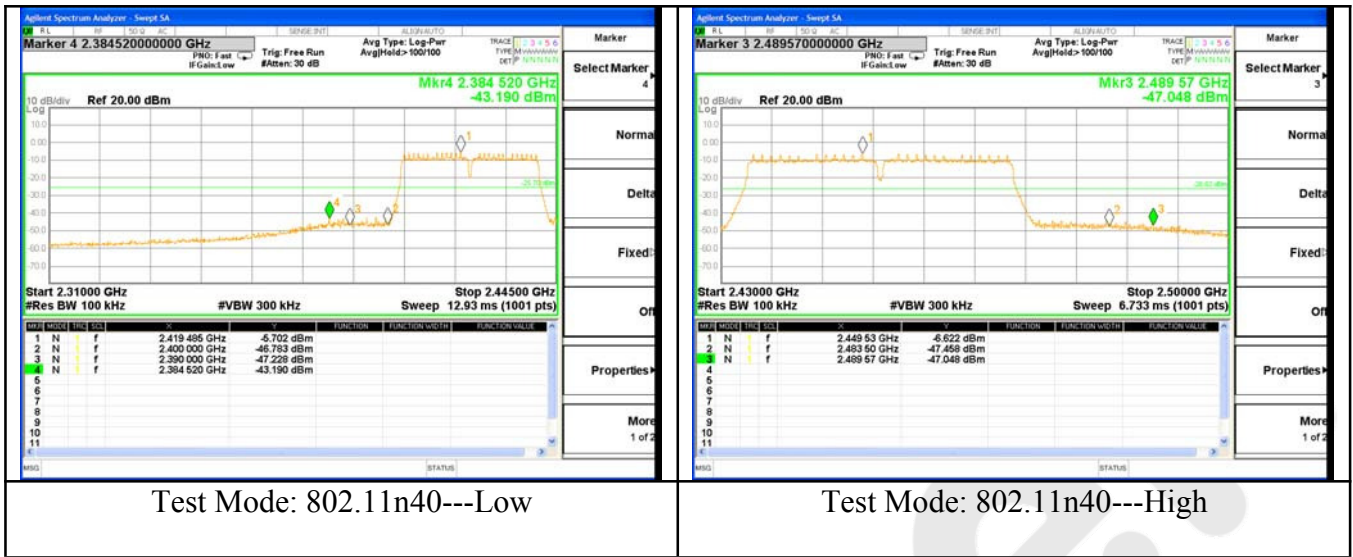

Test Mode: 802.11n40---Low

Test Mode: 802.11n40---High

Anbotek

ANT B

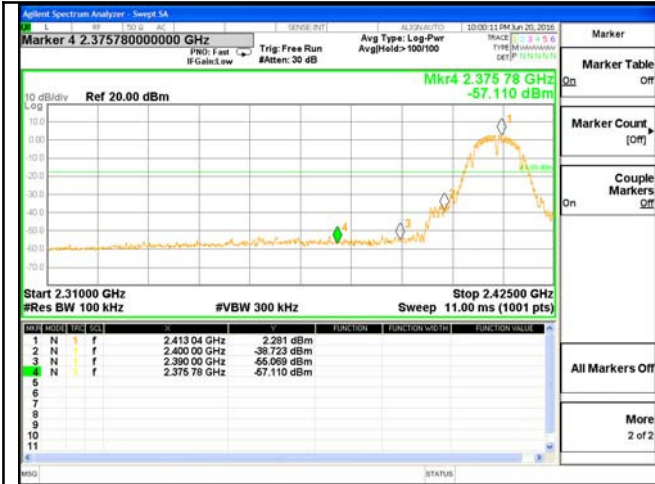

Test Mode: 802.11b---Low



Test Mode: 802.11b---High

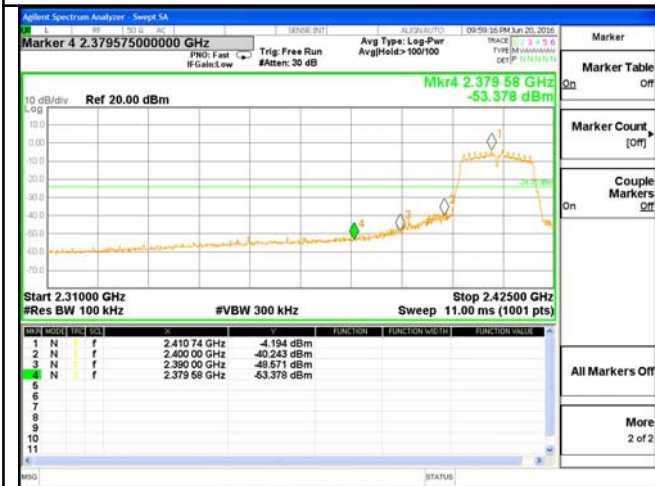

Test Mode: 802.11g---Low



Test Mode: 802.11g---High



Test Mode: 802.11n20---Low



Test Mode: 802.11n20---High



Test Mode: 802.11n40---Low

Test Mode: 802.11n40---High



ANT A

Test Mode: 802.11b

2412MHz

Horizontal-PEAK:

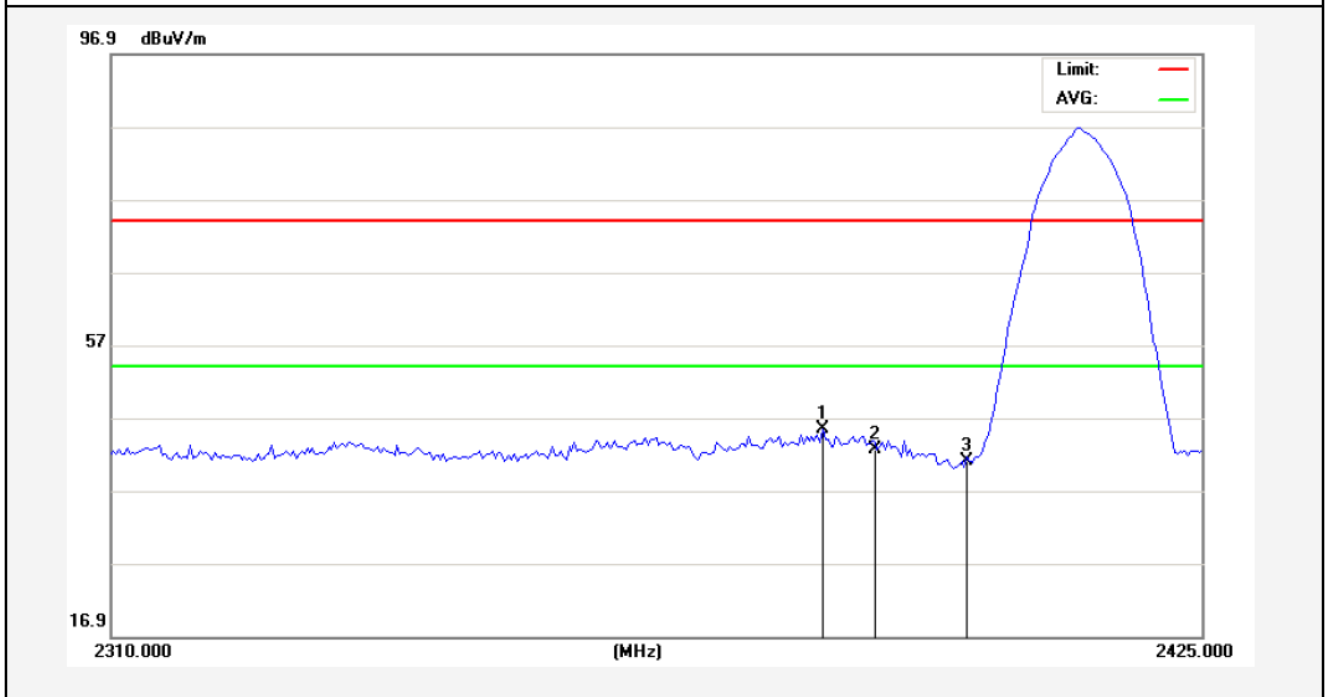

No.	Freq. (MHz)	Reading (dBuV/m)	Factor (dB/m)	Result (dBuV/m)	Limit (dBuV/)	Over Limit (dB)	Detector	Height (cm)	degree (deg)	Remark
1	2384.463	47.97	-2.53	45.44	74.00	-28.56	peak			
2	2390.000	45.15	-2.51	42.64	74.00	-31.36	peak			
3	2400.000	43.50	-2.49	41.01	74.00	-32.99	peak			

ANT A

Horizontal-AV:

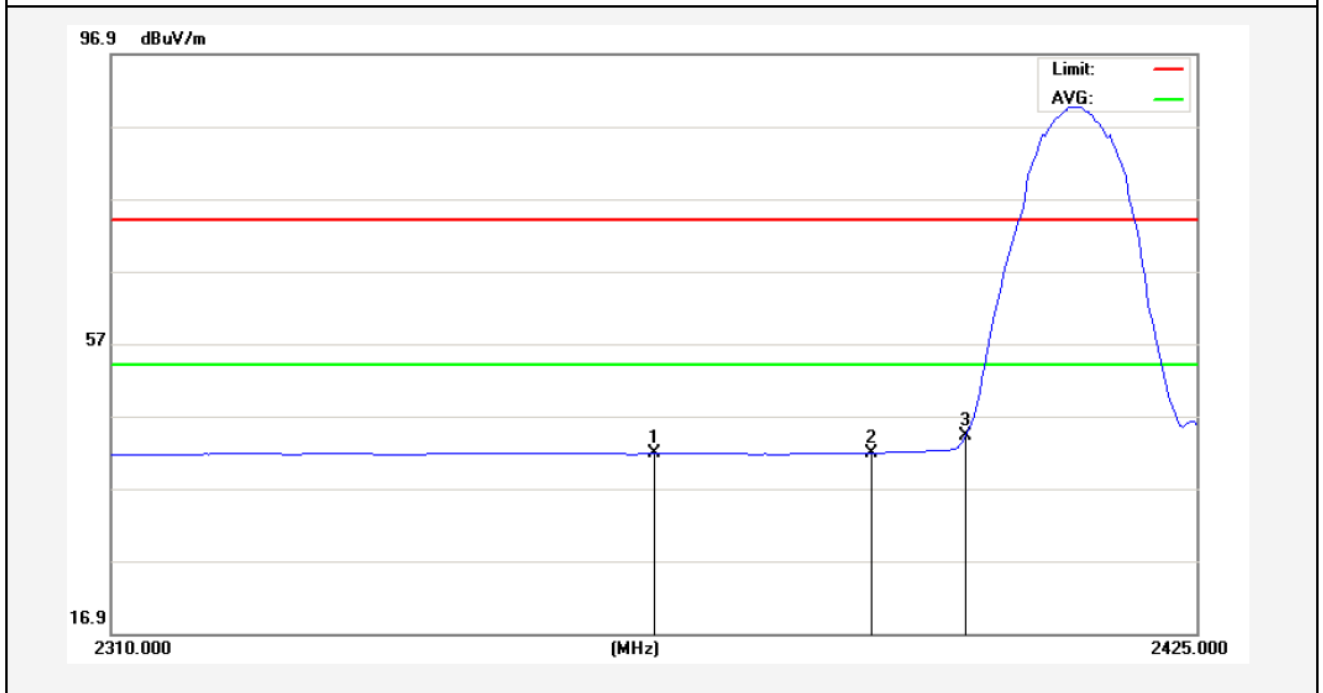

No.	Freq. (MHz)	Reading (dBuV/m)	Factor (dB/m)	Result (dBuV/m)	Limit (dBuV/)	Over Limit (dB)	Detector	Height (cm)	degree (deg)	Remark
1	2366.925	44.33	-2.57	41.76	54.00	-12.24	AVG			
2	2390.000	44.35	-2.51	41.84	54.00	-12.16	AVG			
3	2400.000	46.68	-2.49	44.19	54.00	-9.81	AVG			

Anbotek

Test Mode: 802.11b
2412MHz
Vertical-PEAK:

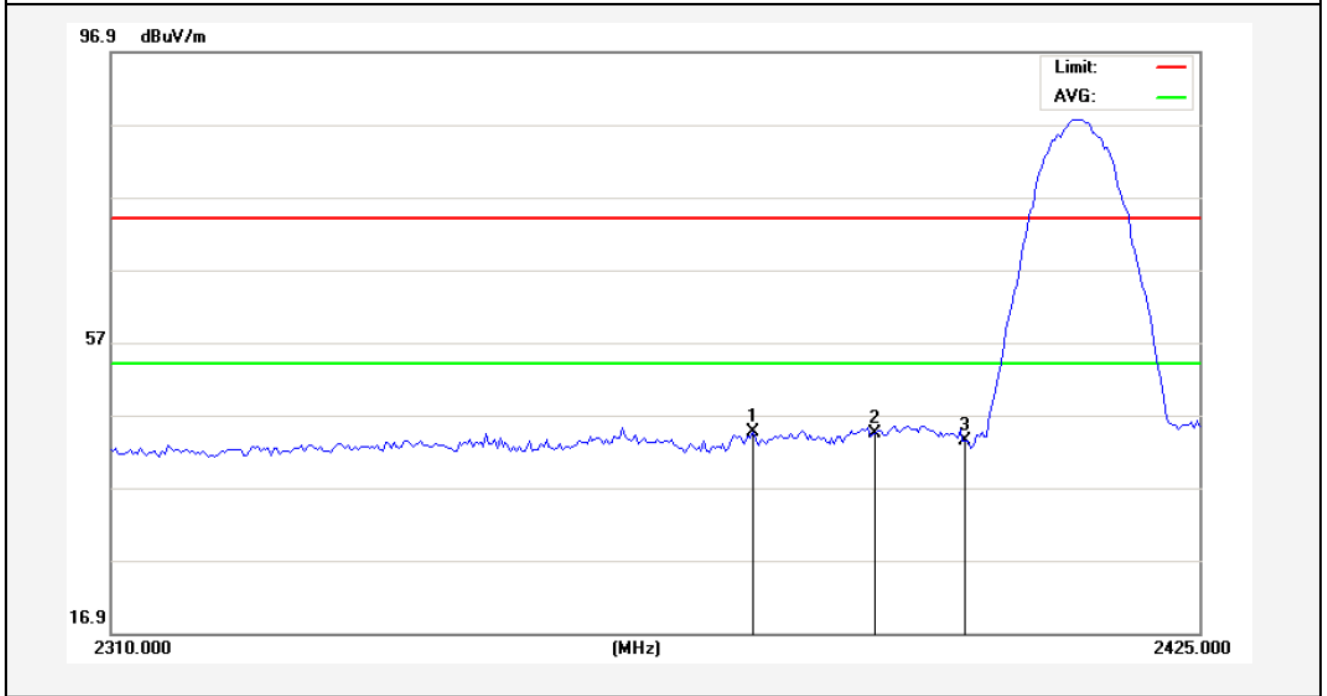

No.	Freq. (MHz)	Reading (dBuV/m)	Factor (dB/m)	Result (dBuV/m)	Limit (dBuV/)	Over Limit (dB)	Detector	Height (cm)	degree (deg)	Remark
1	2377.275	47.18	-2.54	44.64	74.00	-29.36	peak			
2	2390.000	46.98	-2.51	44.47	74.00	-29.53	peak			
3	2400.000	45.92	-2.49	43.43	74.00	-30.57	peak			

AMB

Vertical-AV:

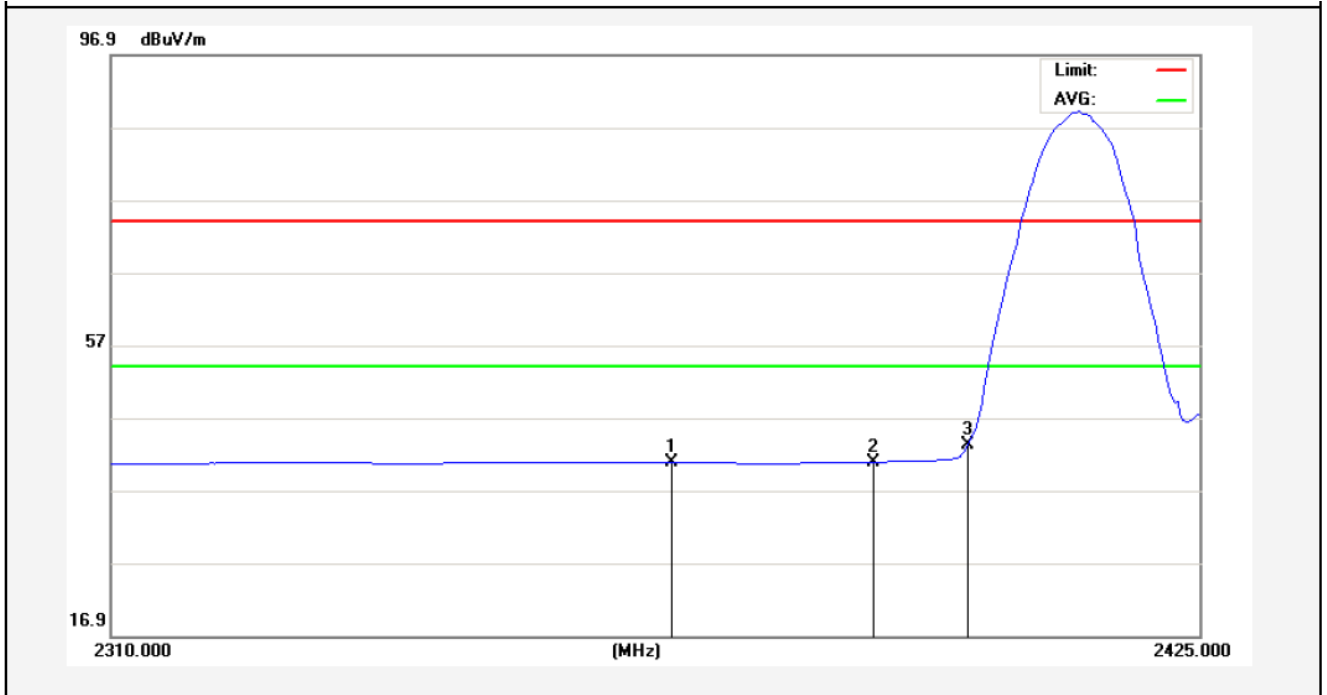

No.	Freq. (MHz)	Reading (dBuV/m)	Factor (dB/m)	Result (dBuV/m)	Limit (dBuV/)	Over Limit (dB)	Detector	Height (cm)	degree (deg)	Remark
1	2368.650	43.35	-2.56	40.79	54.00	-13.21	AVG			
2	2390.000	43.35	-2.51	40.84	54.00	-13.16	AVG			
3	2400.000	45.70	-2.49	43.21	54.00	-10.79	AVG			

Anbotek

Test Mode: 802.11b
2462MHz
Horizontal-PEAK:

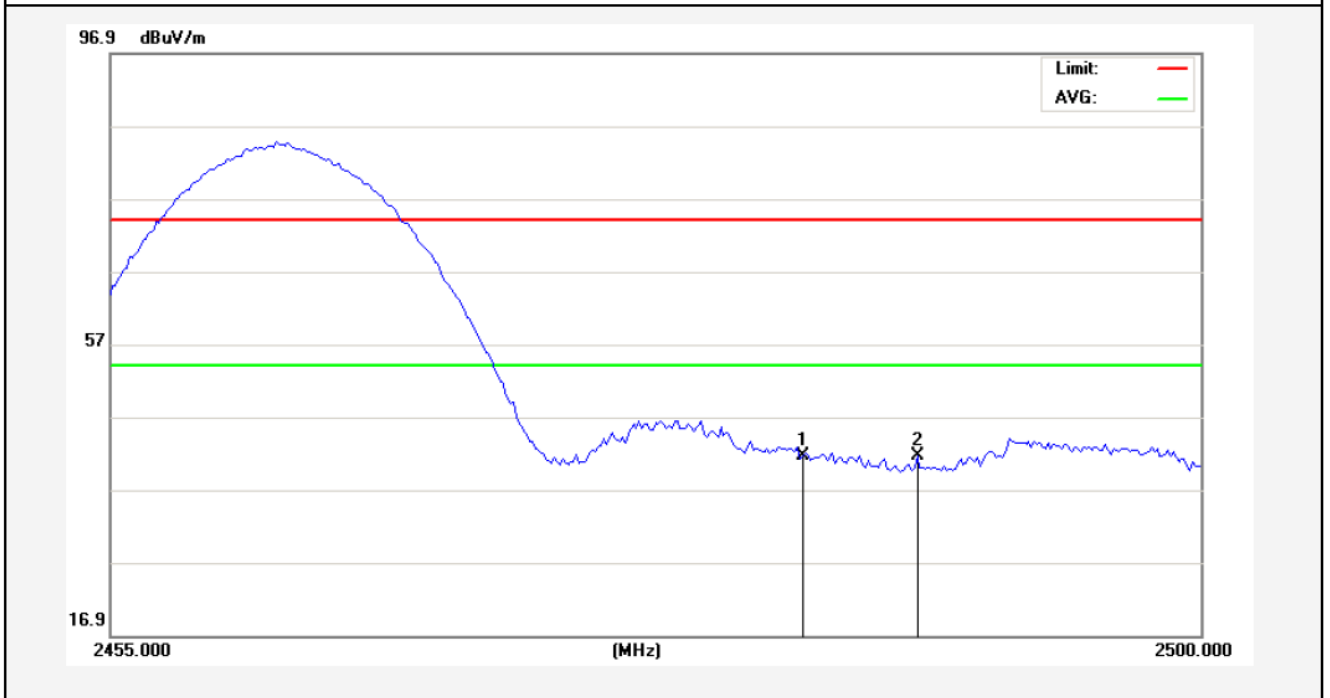

No.	Freq. (MHz)	Reading (dBuV/m)	Factor (dB/m)	Result (dBuV/m)	Limit (dBuV/)	Over Limit (dB)	Detector	Height (cm)	degree (deg)	Remark
1	2483.500	44.00	-2.31	41.69	74.00	-32.31	peak			
2	2488.300	43.88	-2.30	41.58	74.00	-32.42	peak			

Anbotek

Horizontal-AV:

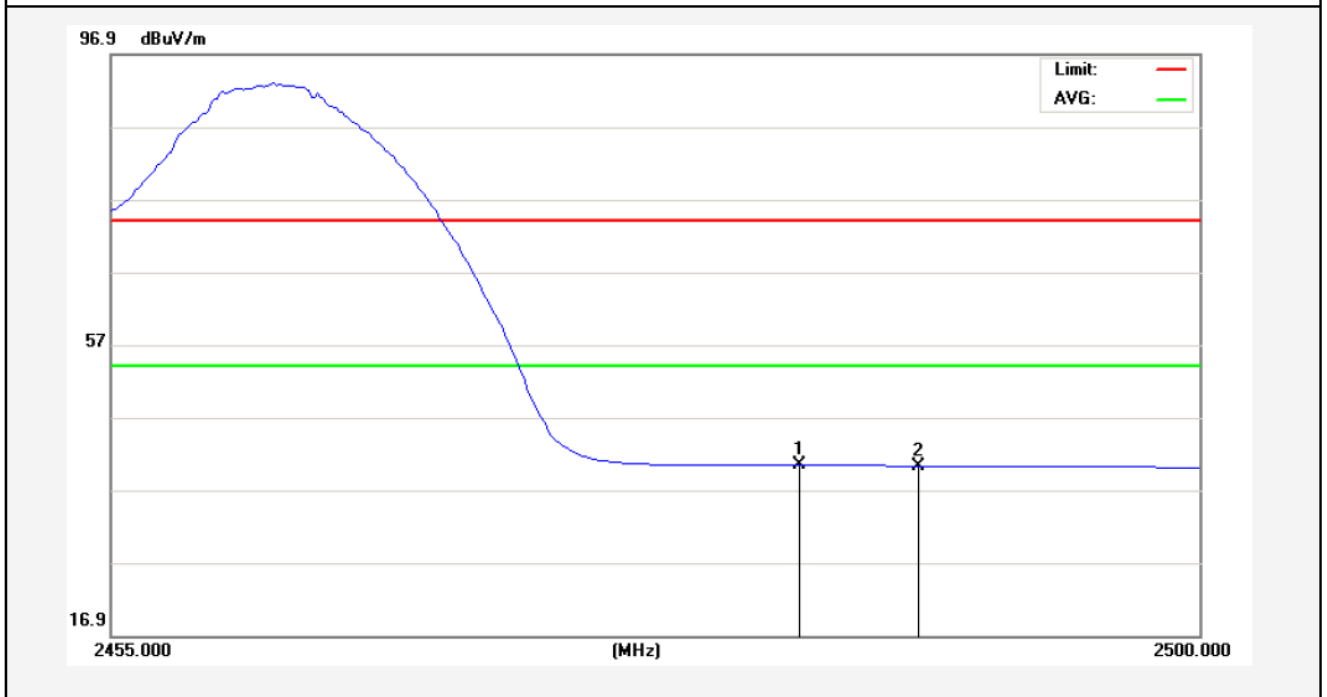

No.	Freq. (MHz)	Reading (dBuV/m)	Factor (dB/m)	Result (dBuV/m)	Limit (dBuV/)	Over Limit (dB)	Detector	Height (cm)	degree (deg)	Remark
1	2483.500	42.72	-2.31	40.41	54.00	-13.59	AVG			
2	2488.412	42.51	-2.30	40.21	54.00	-13.79	AVG			

Anbotek

Test Mode: 802.11b
2462MHz
Vertical-PEAK:

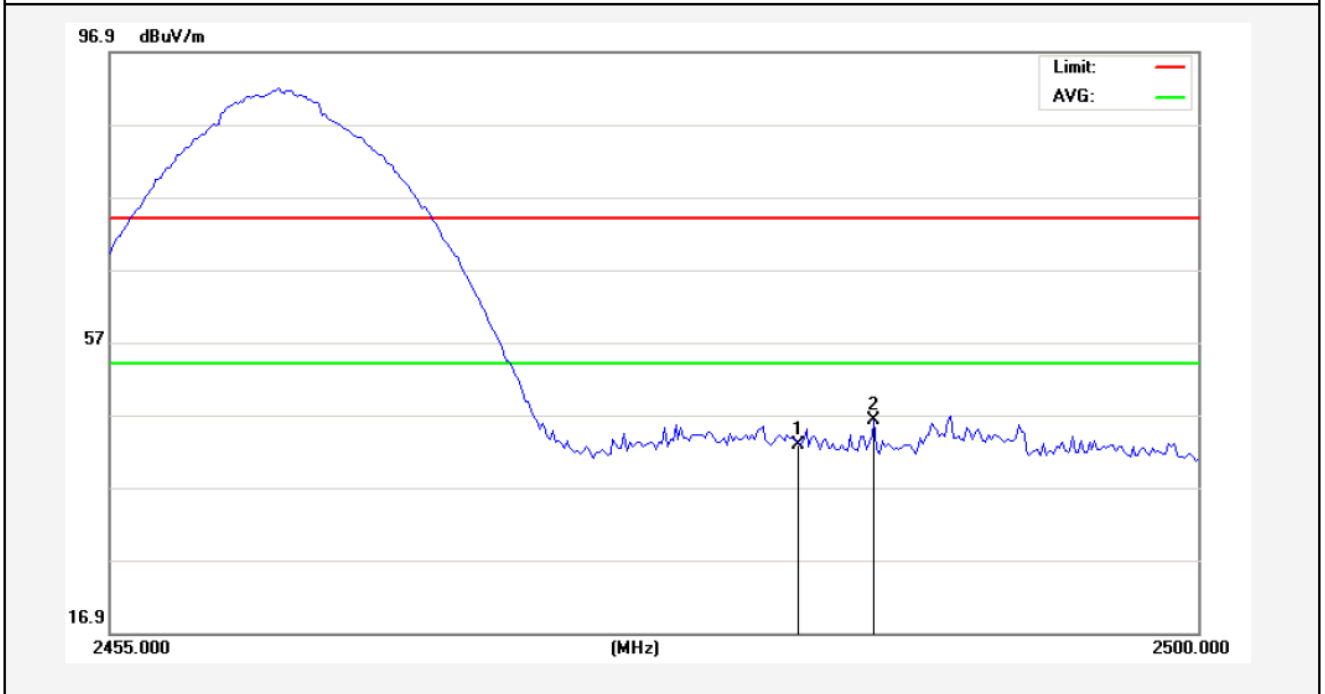

No.	Freq. (MHz)	Reading (dBuV/m)	Factor (dB/m)	Result (dBuV/m)	Limit (dBuV/)	Over Limit (dB)	Detector	Height (cm)	degree (deg)	Remark
1	2483.500	45.19	-2.31	42.88	74.00	-31.12	peak			
2	2486.613	48.53	-2.30	46.23	74.00	-27.77	peak			

Anbotek

Vertical-AV:

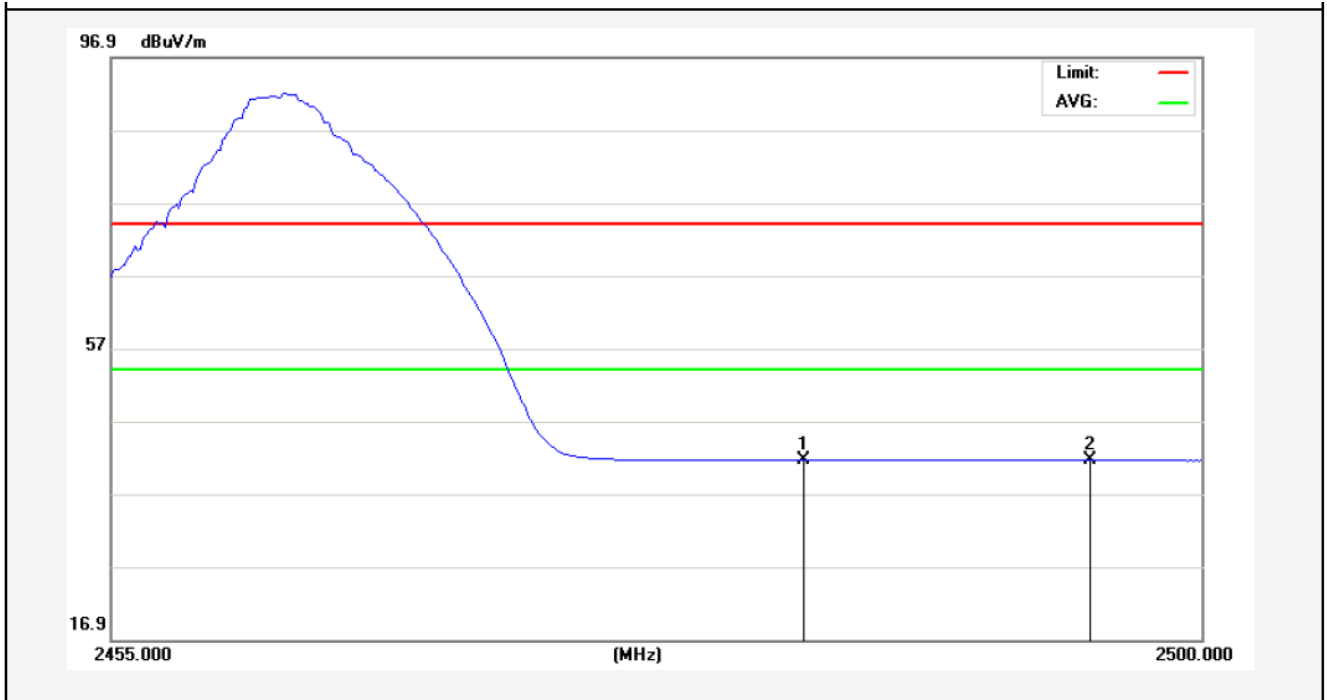

No.	Freq. (MHz)	Reading (dBuV/m)	Factor (dB/m)	Result (dBuV/m)	Limit (dBuV/)	Over Limit (dB)	Detector	Height (cm)	degree (deg)	Remark
1	2483.500	43.97	-2.31	41.66	54.00	-12.34	AVG			
2	2495.387	43.89	-2.28	41.61	54.00	-12.39	AVG			

Anbotek

Test Mode: 802.11g
2412MHz
Horizontal-PEAK:

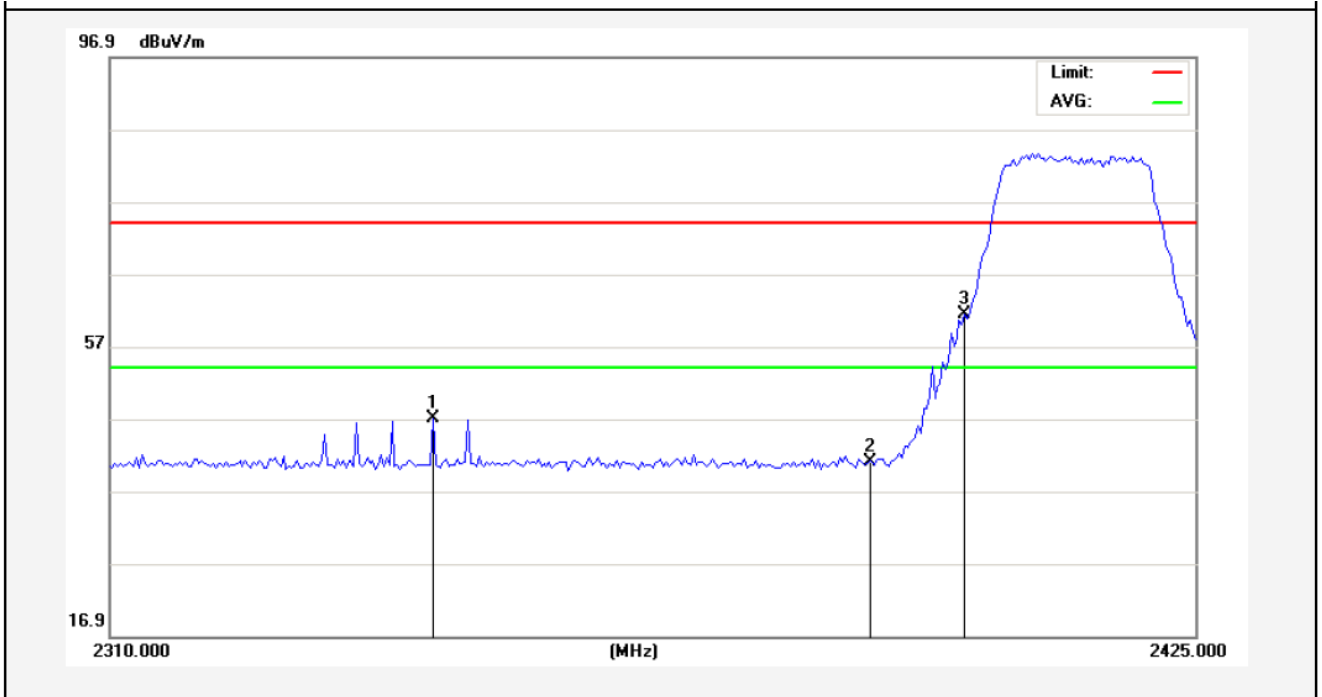

No.	Freq. (MHz)	Reading (dBuV/m)	Factor (dB/m)	Result (dBuV/m)	Limit (dBuV/)	Over Limit (dB)	Detector	Height (cm)	degree (deg)	Remark
1	2343.637	49.72	-2.62	47.10	74.00	-26.90	peak			
2	2390.000	43.61	-2.51	41.10	74.00	-32.90	peak			
3	2400.000	63.90	-2.49	61.41	74.00	-12.59	peak			

AMB

Horizontal-AV:

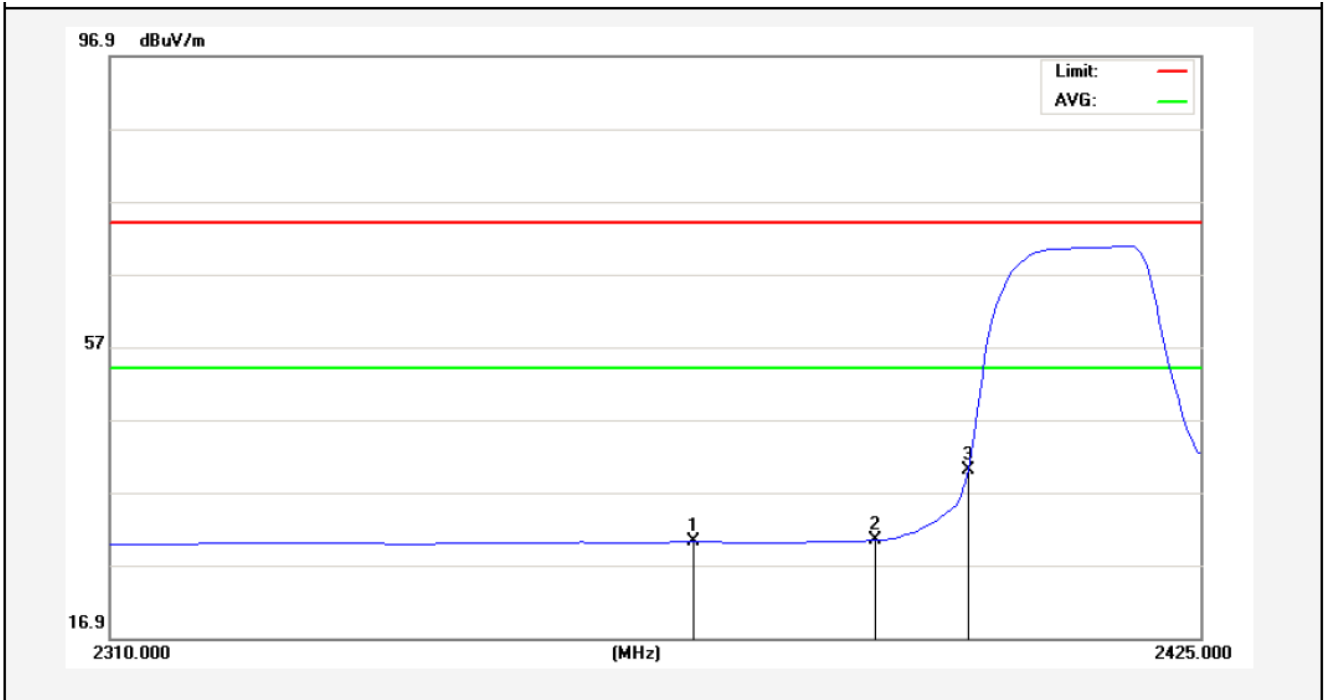

No.	Freq. (MHz)	Reading (dBuV/m)	Factor (dB/m)	Result (dBuV/m)	Limit (dBuV/)	Over Limit (dB)	Detector	Height (cm)	degree (deg)	Remark
1	2370.950	32.77	-2.56	30.21	54.00	-23.79	AVG			
2	2390.000	32.82	-2.51	30.31	54.00	-23.69	AVG			
3	2400.000	42.56	-2.49	40.07	54.00	-13.93	AVG			

Anbotek

Test Mode: 802.11g
2412MHz
Vertical-PEAK:

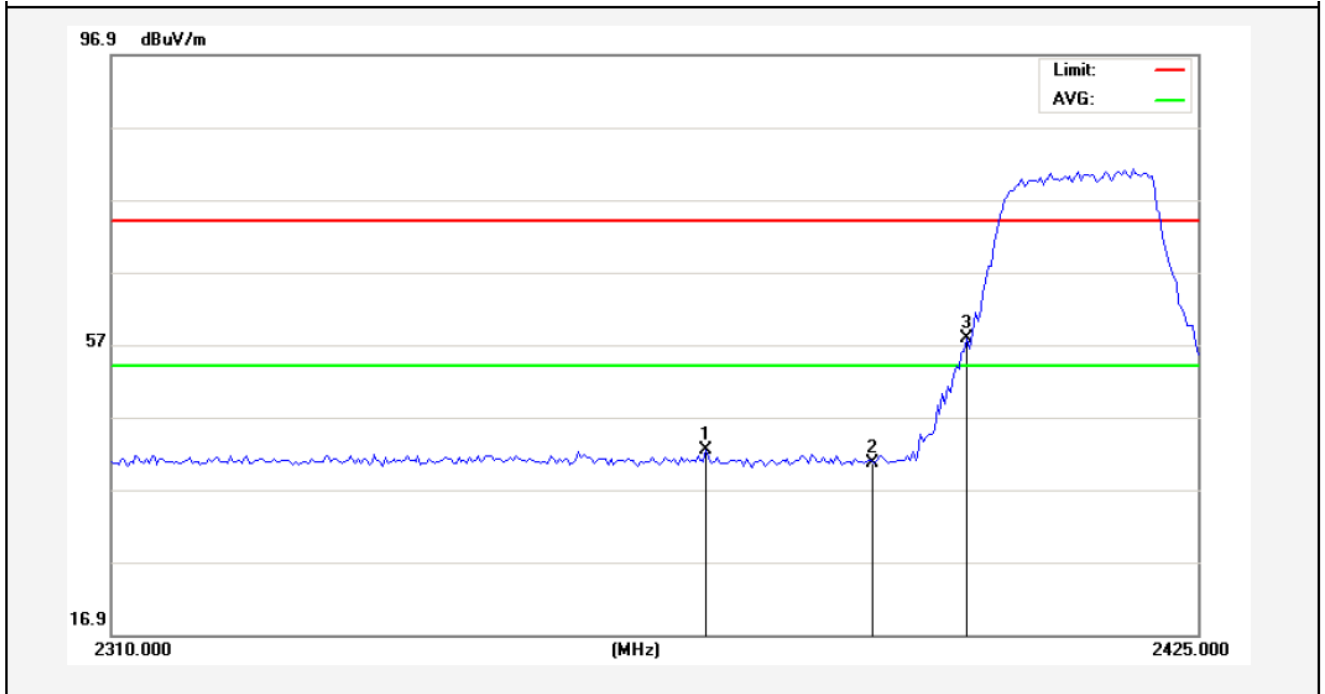

No.	Freq. (MHz)	Reading (dBuV/m)	Factor (dB/m)	Result (dBuV/m)	Limit (dBuV/)	Over Limit (dB)	Detector	Height (cm)	degree (deg)	Remark
1	2372.387	44.90	-2.55	42.35	74.00	-31.65	peak			
2	2390.000	43.07	-2.51	40.56	74.00	-33.44	peak			
3	2400.000	60.36	-2.49	57.87	74.00	-16.13	peak			

Anbotek

Vertical-AV:

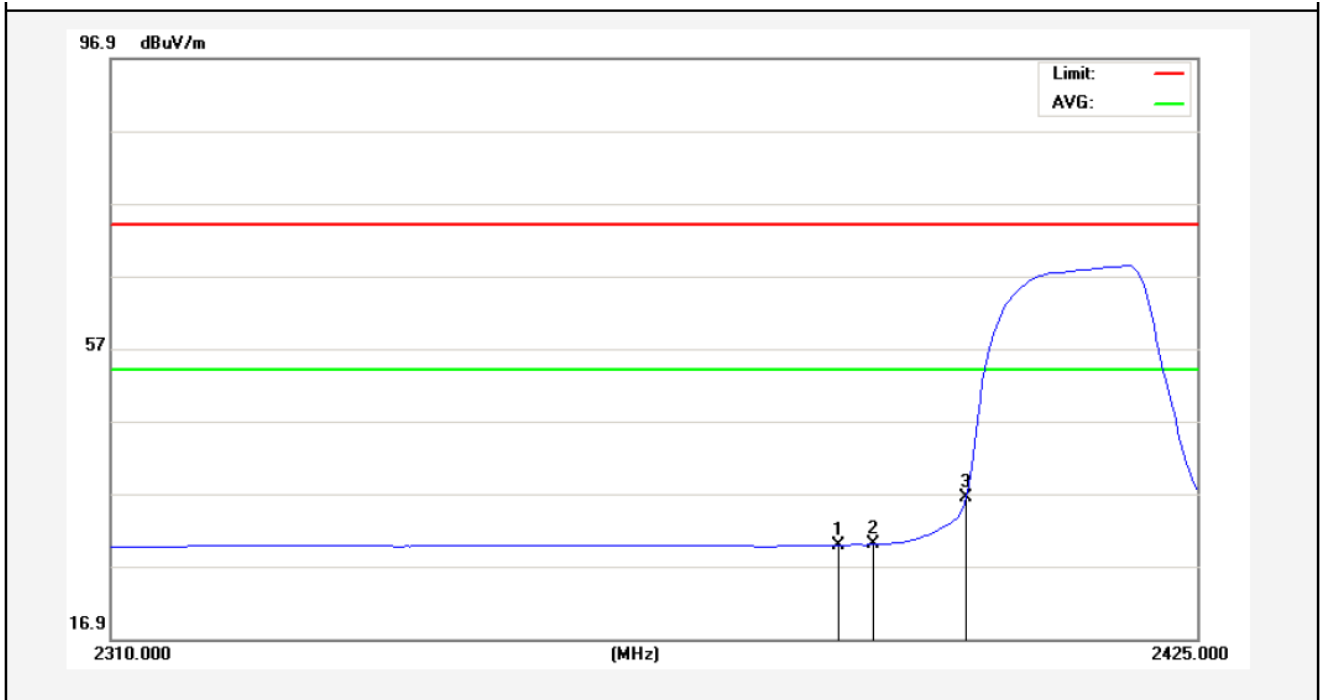

No.	Freq. (MHz)	Reading (dBuV/m)	Factor (dB/m)	Result (dBuV/m)	Limit (dBuV/)	Over Limit (dB)	Detector	Height (cm)	degree (deg)	Remark
1	2386.188	32.38	-2.52	29.86	54.00	-24.14	AVG			
2	2390.000	32.44	-2.51	29.93	54.00	-24.07	AVG			
3	2400.000	38.95	-2.49	36.46	54.00	-17.54	AVG			

Anbotek

Test Mode: 802.11g
2462MHz
Horizontal-PEAK:

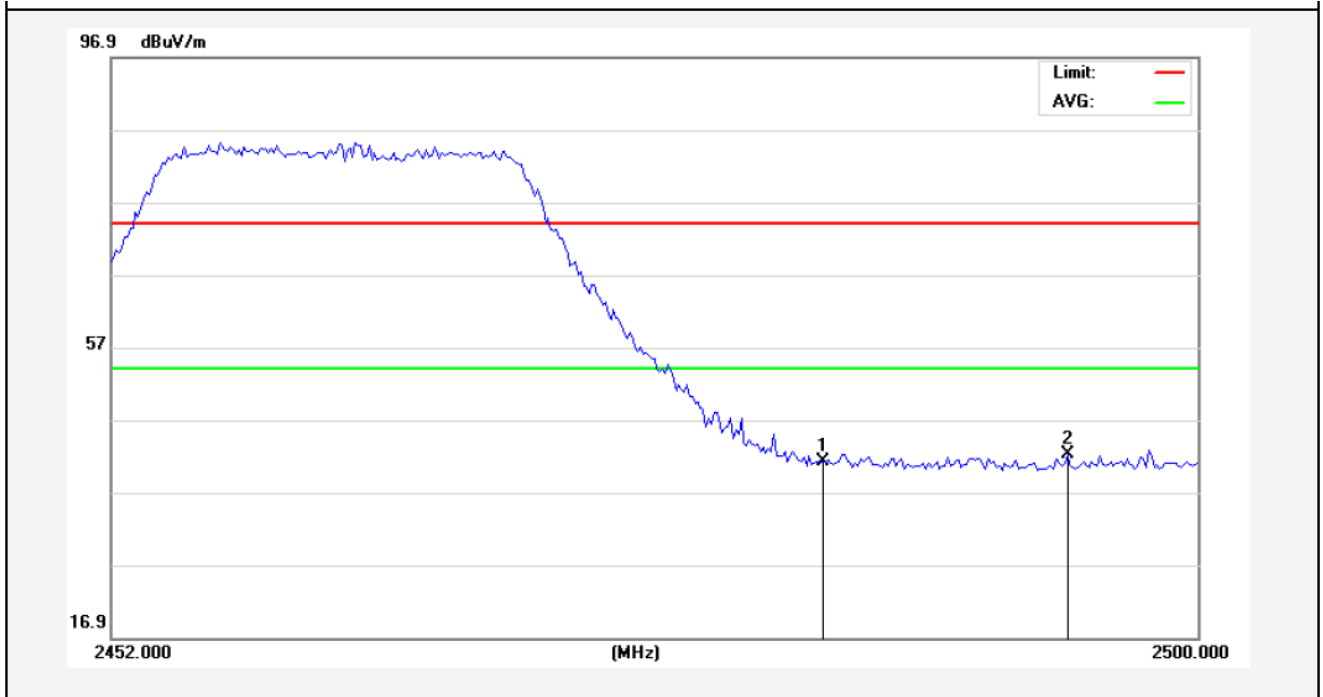

No.	Freq. (MHz)	Reading (dBuV/m)	Factor (dB/m)	Result (dBuV/m)	Limit (dBuV/)	Over Limit (dB)	Detector	Height (cm)	degree (deg)	Remark
1	2483.500	43.54	-2.31	41.23	74.00	-32.77	peak			
2	2494.240	44.40	-2.28	42.12	74.00	-31.88	peak			

Anbotek

Horizontal-AV:

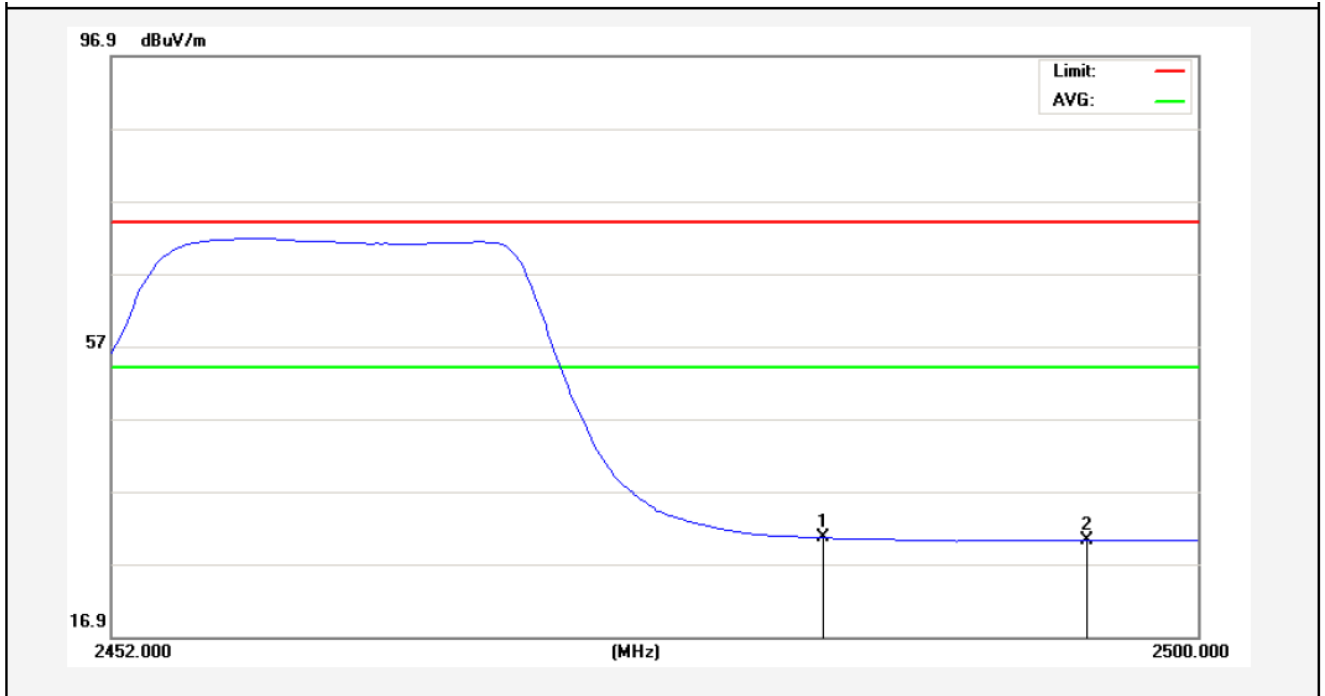

No.	Freq. (MHz)	Reading (dBuV/m)	Factor (dB/m)	Result (dBuV/m)	Limit (dBuV/)	Over Limit (dB)	Detector	Height (cm)	degree (deg)	Remark
1	2483.500	32.85	-2.31	30.54	54.00	-23.46	AVG			
2	2495.080	32.55	-2.28	30.27	54.00	-23.73	AVG			

Anbotek

Test Mode: 802.11g
2462MHz
Vertical-PEAK:

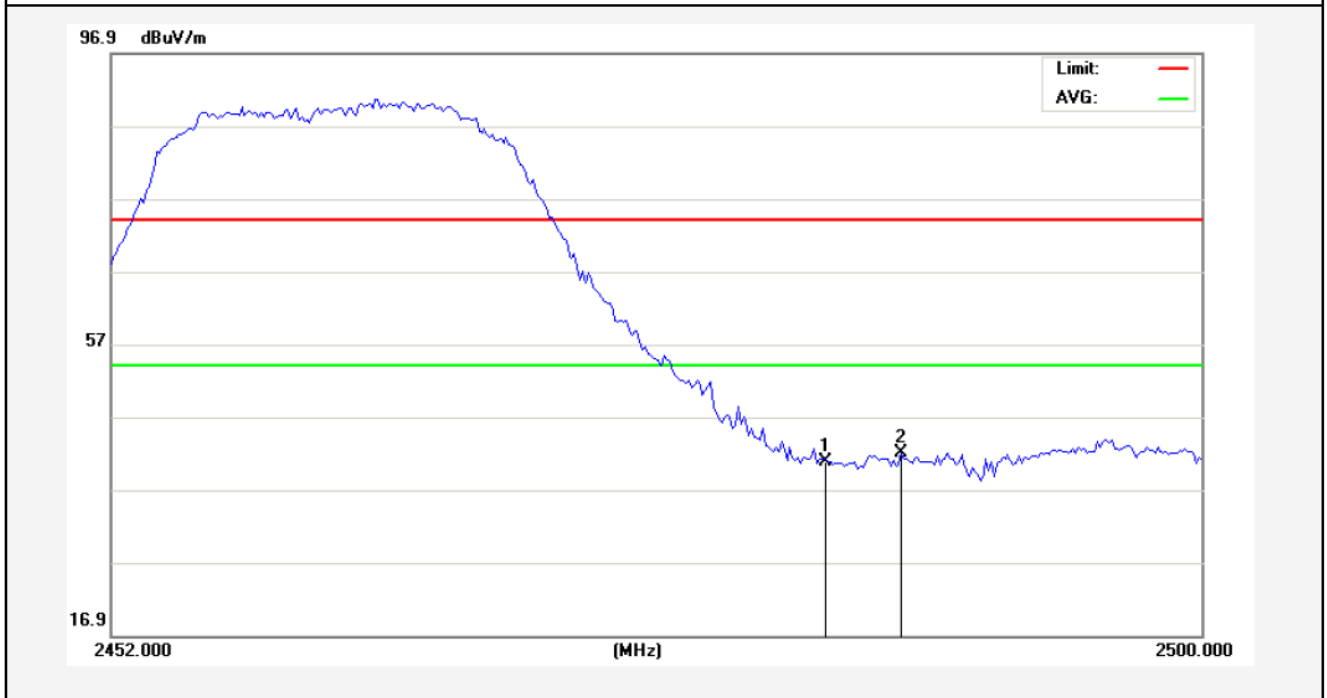

No.	Freq. (MHz)	Reading (dBuV/m)	Factor (dB/m)	Result (dBuV/m)	Limit (dBuV/)	Over Limit (dB)	Detector	Height (cm)	degree (deg)	Remark
1	2483.500	43.14	-2.31	40.83	74.00	-33.17	peak			
2	2486.800	44.37	-2.30	42.07	74.00	-31.93	peak			

Anbotek

Vertical-AV:

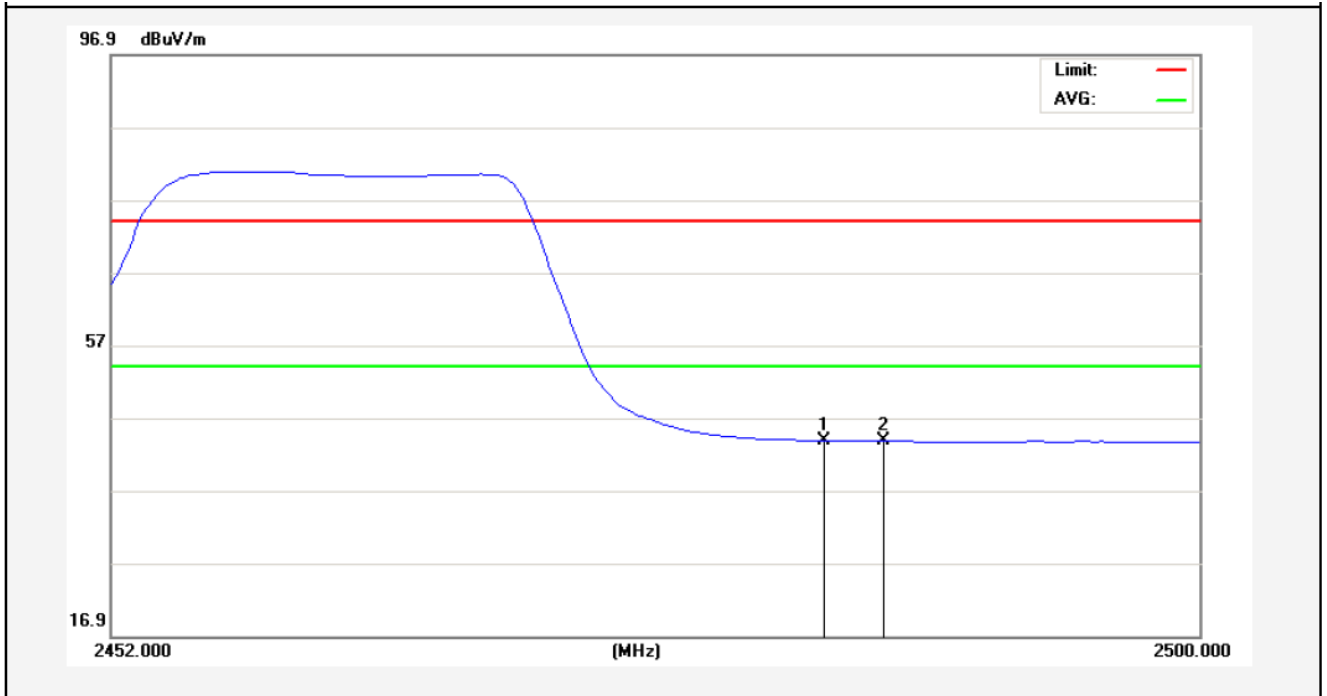

No.	Freq. (MHz)	Reading (dBuV/m)	Factor (dB/m)	Result (dBuV/m)	Limit (dBuV/)	Over Limit (dB)	Detector	Height (cm)	degree (deg)	Remark
1	2483.500	46.17	-2.31	43.86	54.00	-10.14	AVG			
2	2486.080	46.08	-2.30	43.78	54.00	-10.22	AVG			

Anbotek

Test Mode: 802.11n (HT20)

2412MHz

Horizontal-PEAK:

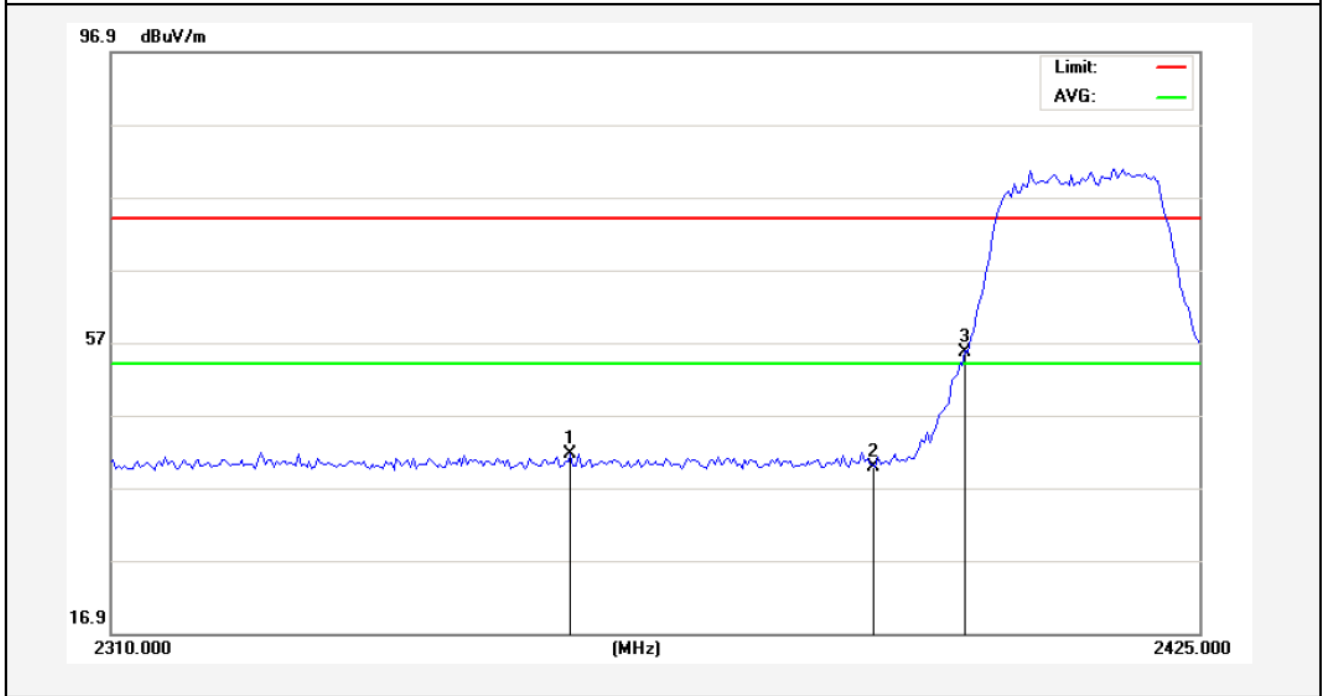

No.	Freq. (MHz)	Reading (dBuV/m)	Factor (dB/m)	Result (dBuV/m)	Limit (dBuV/)	Over Limit (dB)	Detector	Height (cm)	degree (deg)	Remark
1	2358.012	44.13	-2.59	41.54	74.00	-32.46	peak			
2	2390.000	42.35	-2.51	39.84	74.00	-34.16	peak			
3	2400.000	58.15	-2.49	55.66	74.00	-18.34	peak			

Anbotek

Horizontal-AV:

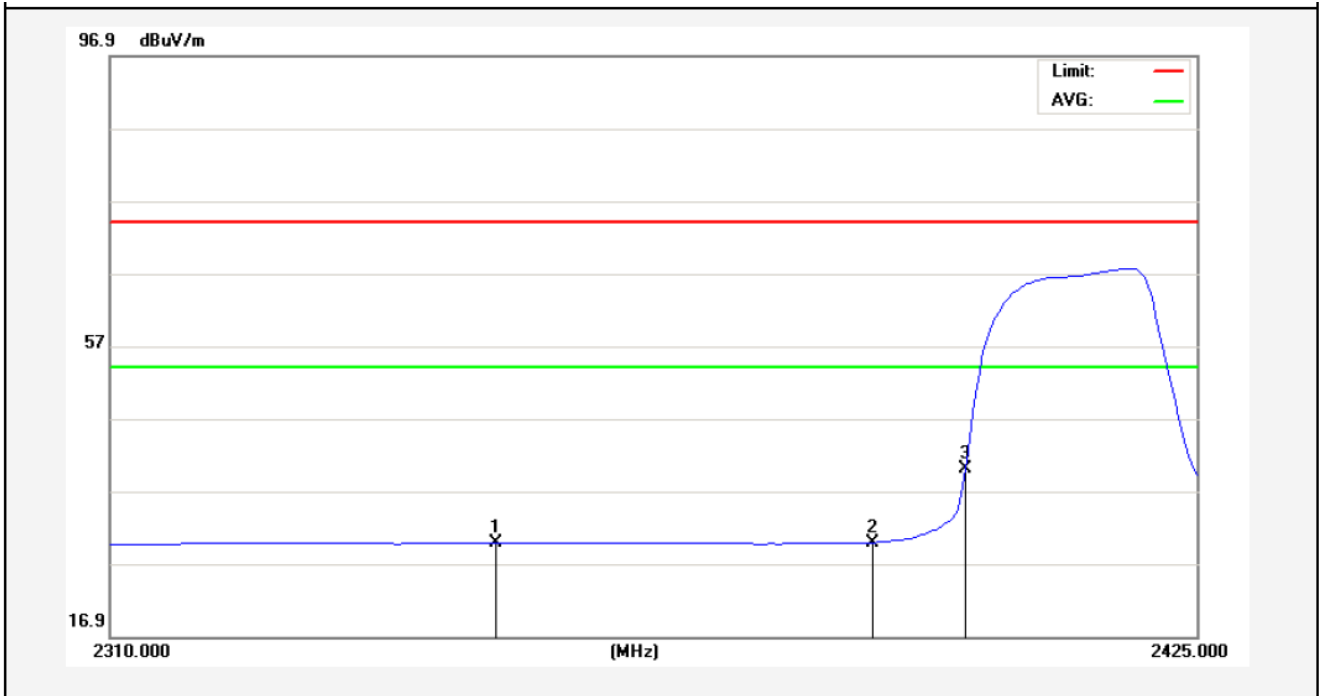

No.	Freq. (MHz)	Reading (dBuV/m)	Factor (dB/m)	Result (dBuV/m)	Limit (dBuV/)	Over Limit (dB)	Detector	Height (cm)	degree (deg)	Remark
1	2350.250	32.48	-2.60	29.88	54.00	-24.12	AVG			
2	2390.000	32.41	-2.51	29.90	54.00	-24.10	AVG			
3	2400.000	42.45	-2.49	39.96	54.00	-14.04	AVG			

Anbotek

Test Mode: 802.11n (HT20)
2412MHz
Vertical-PEAK:

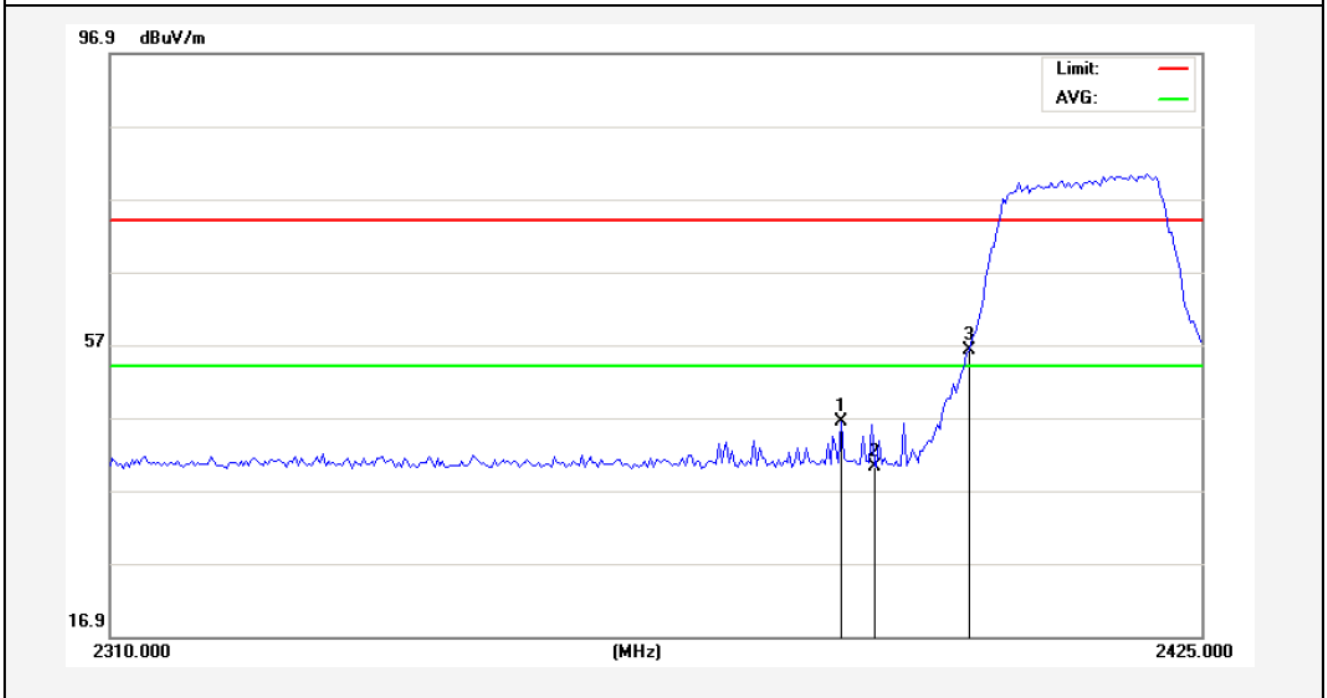

No.	Freq. (MHz)	Reading (dBuV/m)	Factor (dB/m)	Result (dBuV/m)	Limit (dBuV/)	Over Limit (dB)	Detector	Height (cm)	degree (deg)	Remark
1	2386.475	48.95	-2.52	46.43	74.00	-27.57	peak			
2	2390.000	42.70	-2.51	40.19	74.00	-33.81	peak			
3	2400.000	58.74	-2.49	56.25	74.00	-17.75	peak			

Anbotek

Vertical-AV:

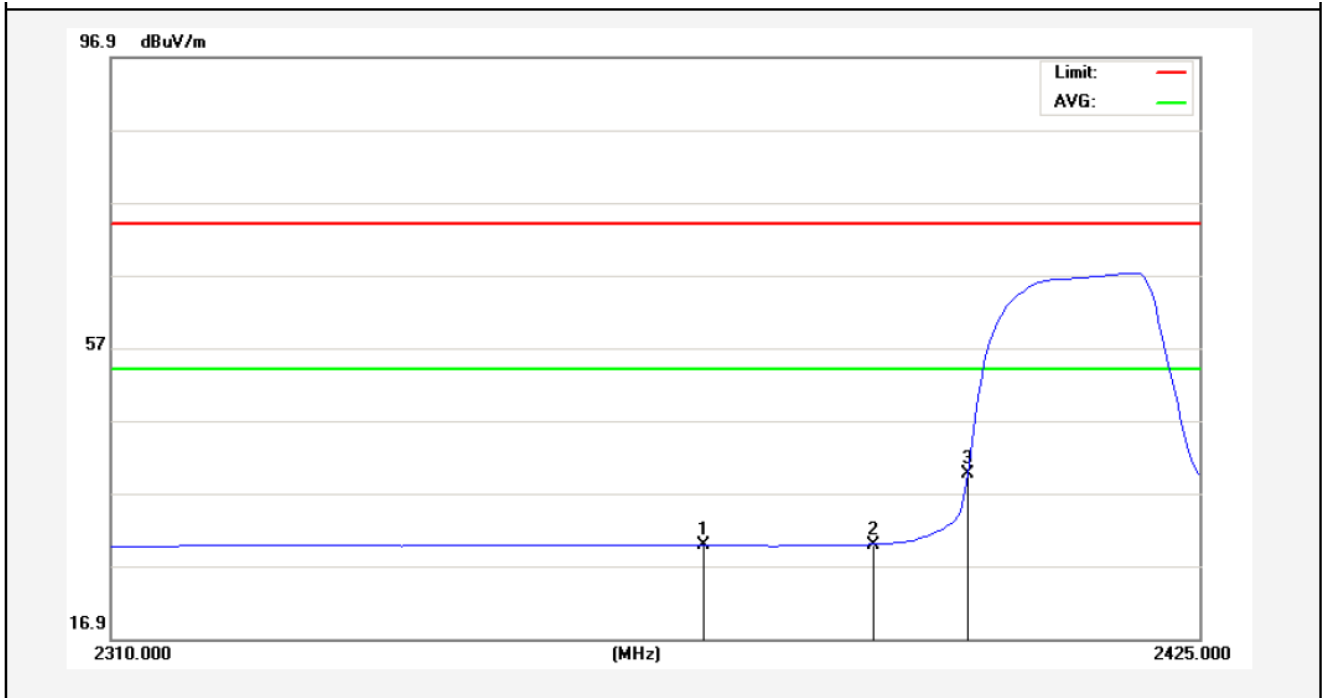

No.	Freq. (MHz)	Reading (dBuV/m)	Factor (dB/m)	Result (dBuV/m)	Limit (dBuV/)	Over Limit (dB)	Detector	Height (cm)	degree (deg)	Remark
1	2372.100	32.37	-2.55	29.82	54.00	-24.18	AVG			
2	2390.000	32.41	-2.51	29.90	54.00	-24.10	AVG			
3	2400.000	42.13	-2.49	39.64	54.00	-14.36	AVG			

Anbotek

Test Mode: 802.11n (HT20)

2462MHz

Horizontal-PEAK:

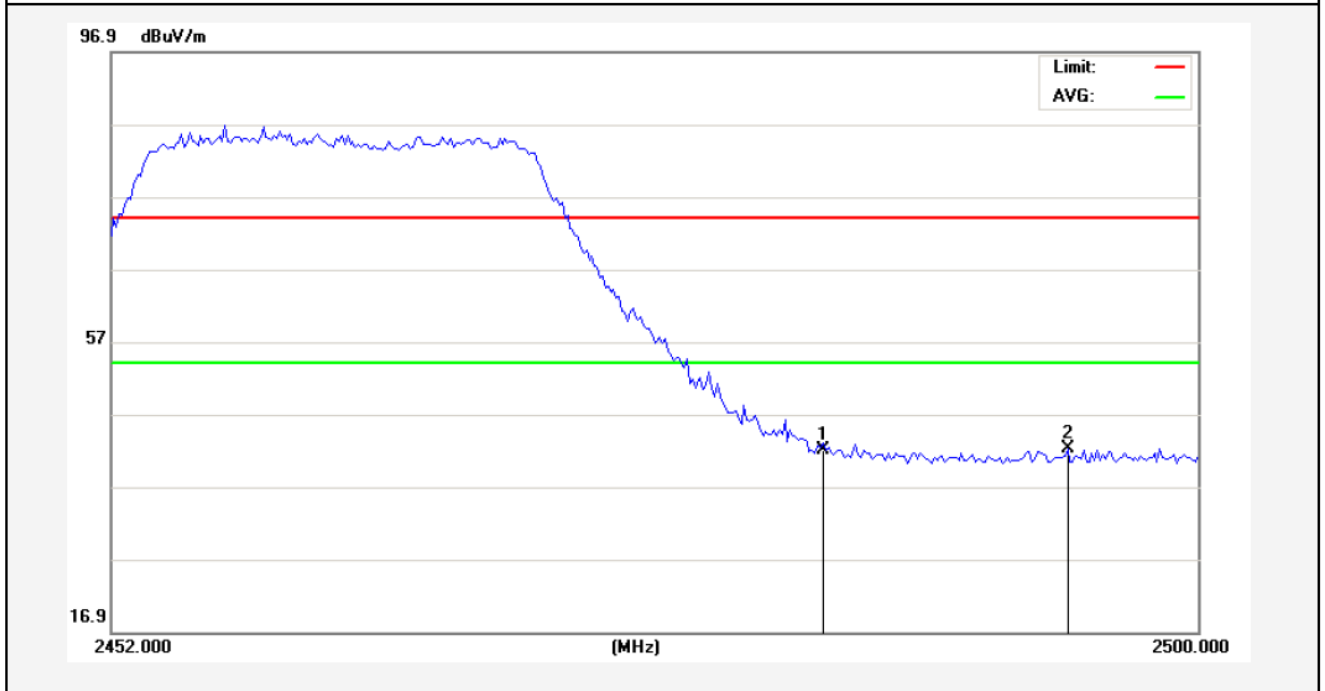

No.	Freq. (MHz)	Reading (dBuV/m)	Factor (dB/m)	Result (dBuV/m)	Limit (dBuV/)	Over Limit (dB)	Detector	Height (cm)	degree (deg)	Remark
1	2483.500	44.23	-2.31	41.92	74.00	-32.08	peak			
2	2494.240	44.43	-2.28	42.15	74.00	-31.85	peak			

Anbotek

Horizontal-AV:

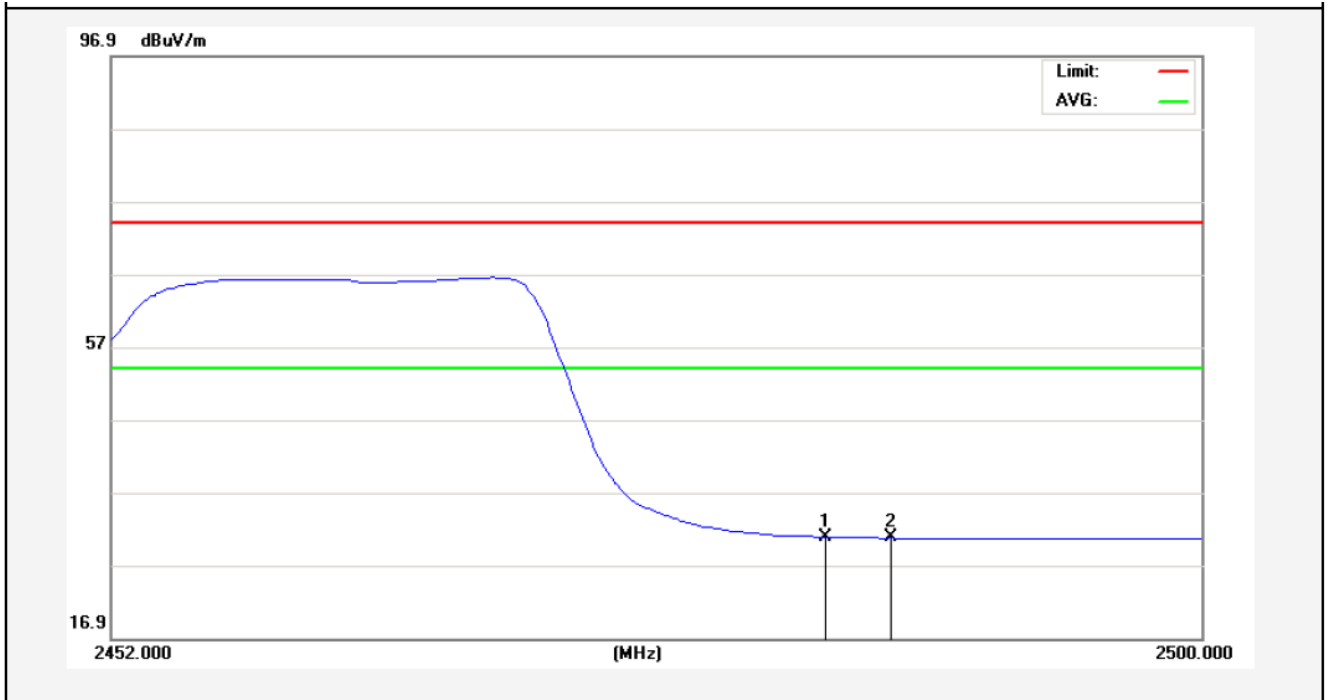

No.	Freq. (MHz)	Reading (dBuV/m)	Factor (dB/m)	Result (dBuV/m)	Limit (dBuV/)	Over Limit (dB)	Detector	Height (cm)	degree (deg)	Remark
1	2483.500	33.14	-2.31	30.83	54.00	-23.17	AVG			
2	2486.320	33.02	-2.30	30.72	54.00	-23.28	AVG			

Anbotek

Test Mode: 802.11n (HT20)

2462MHz

Vertical-PEAK:

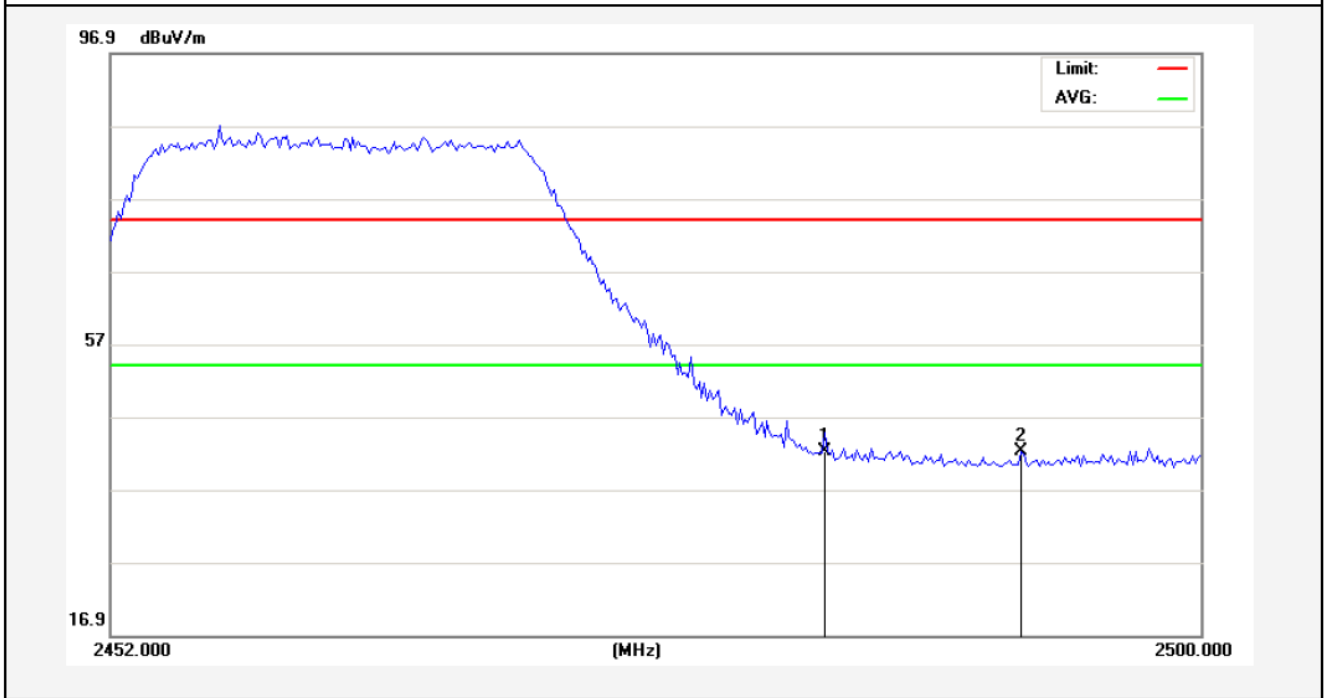

No.	Freq. (MHz)	Reading (dBuV/m)	Factor (dB/m)	Result (dBuV/m)	Limit (dBuV/)	Over Limit (dB)	Detector	Height (cm)	degree (deg)	Remark
1	2483.500	44.54	-2.31	42.23	74.00	-31.77	peak			
2	2492.080	44.59	-2.29	42.30	74.00	-31.70	peak			

Anbotek

Vertical-AV:

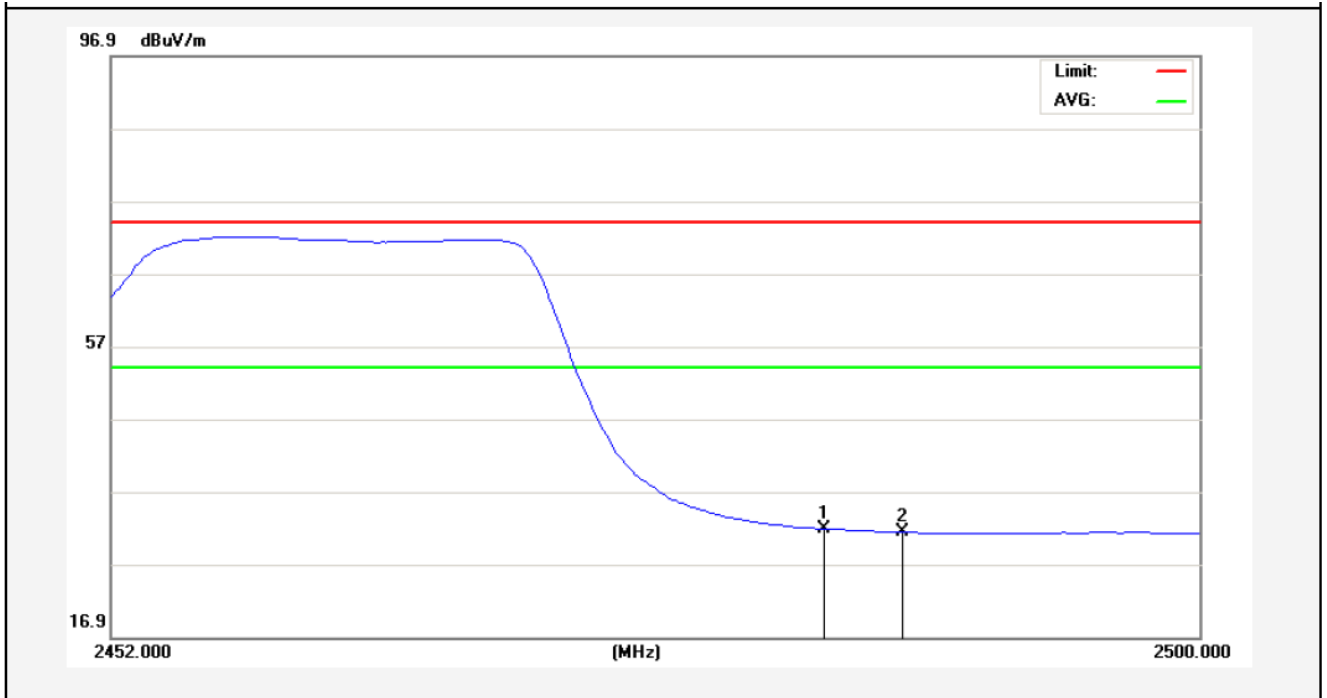

No.	Freq. (MHz)	Reading (dBuV/m)	Factor (dB/m)	Result (dBuV/m)	Limit (dBuV/)	Over Limit (dB)	Detector	Height (cm)	degree (deg)	Remark
1	2483.500	34.13	-2.31	31.82	54.00	-22.18	AVG			
2	2486.920	33.68	-2.30	31.38	54.00	-22.62	AVG			

Anbotek

Test Mode: 802.11n (HT40)

2422MHz

Horizontal-PEAK:

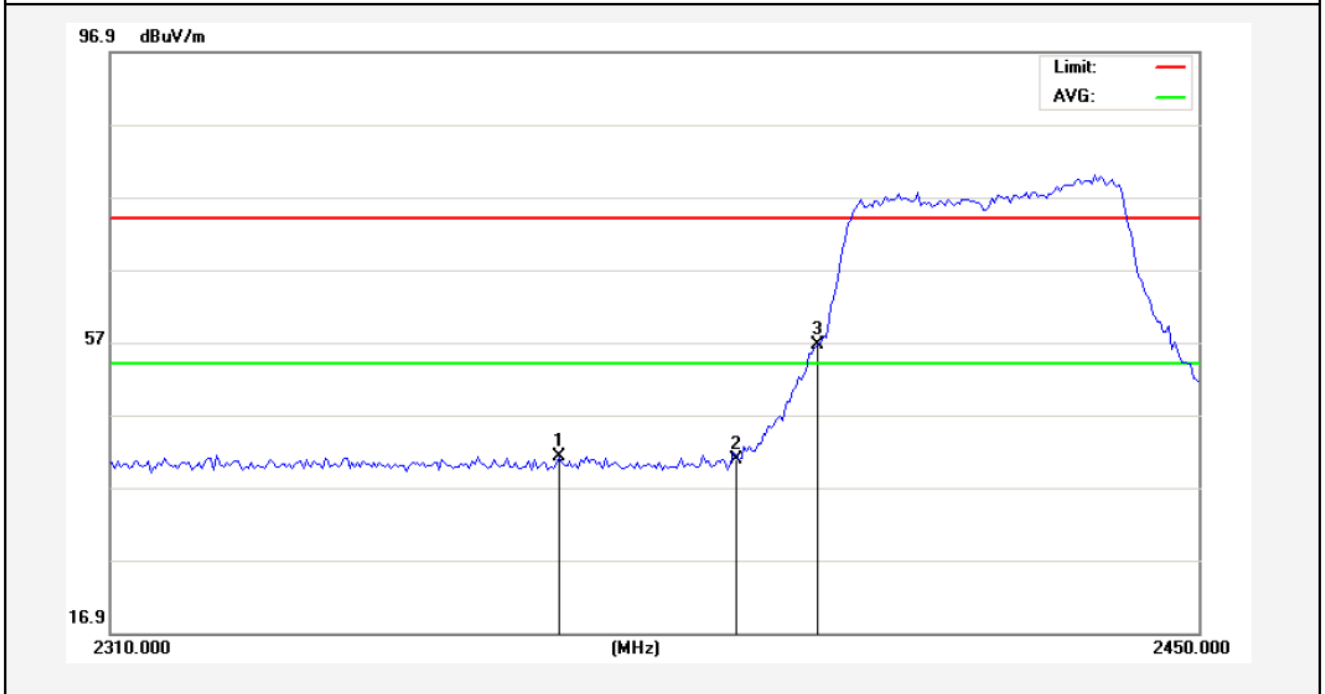

No.	Freq. (MHz)	Reading (dBuV/m)	Factor (dB/m)	Result (dBuV/m)	Limit (dBuV/)	Over Limit (dB)	Detector	Height (cm)	degree (deg)	Remark
1	2367.050	43.83	-2.57	41.26	74.00	-32.74	peak			
2	2390.000	43.36	-2.51	40.85	74.00	-33.15	peak			
3	2400.000	59.16	-2.49	56.67	74.00	-17.33	peak			

Anbotek

Horizontal-AV:

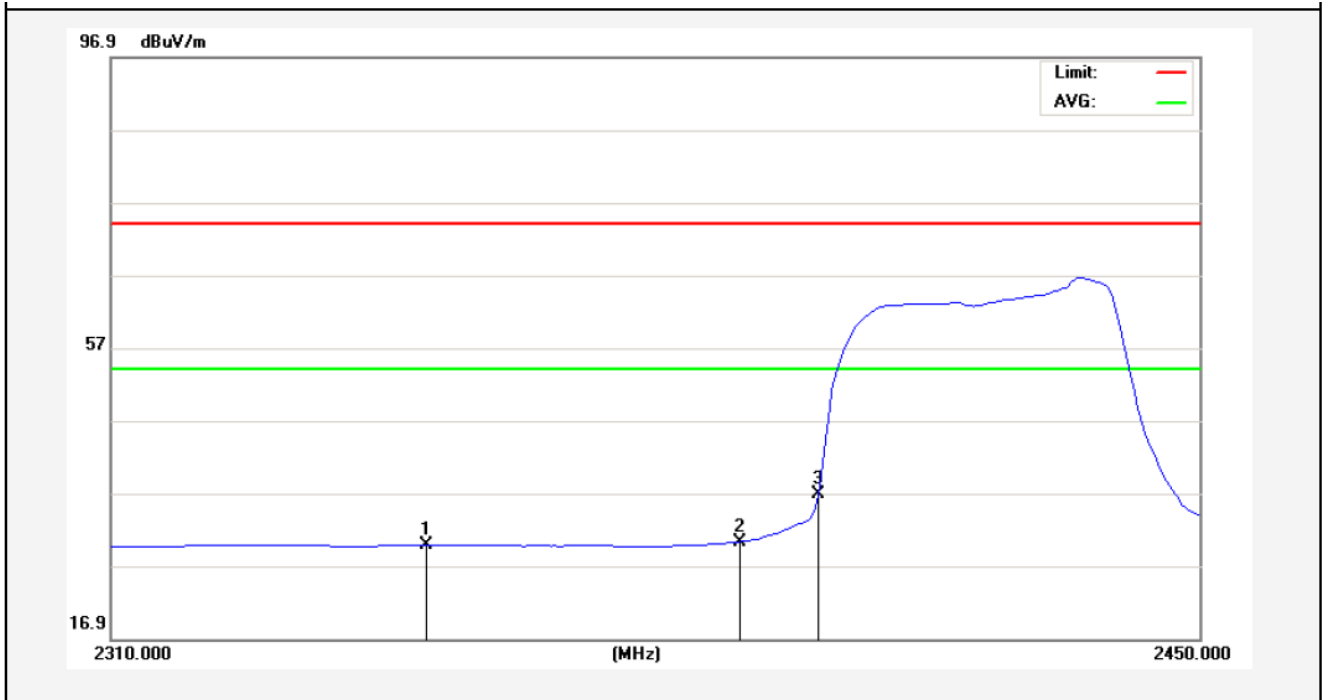

No.	Freq. (MHz)	Reading (dBuV/m)	Factor (dB/m)	Result (dBuV/m)	Limit (dBuV/)	Over Limit (dB)	Detector	Height (cm)	degree (deg)	Remark
1	2349.900	32.43	-2.60	29.83	54.00	-24.17	AVG			
2	2390.000	32.75	-2.51	30.24	54.00	-23.76	AVG			
3	2400.000	39.34	-2.49	36.85	54.00	-17.15	AVG			

Anbotek

Test Mode: 802.11n (HT40)

2422MHz

Vertical-PEAK:

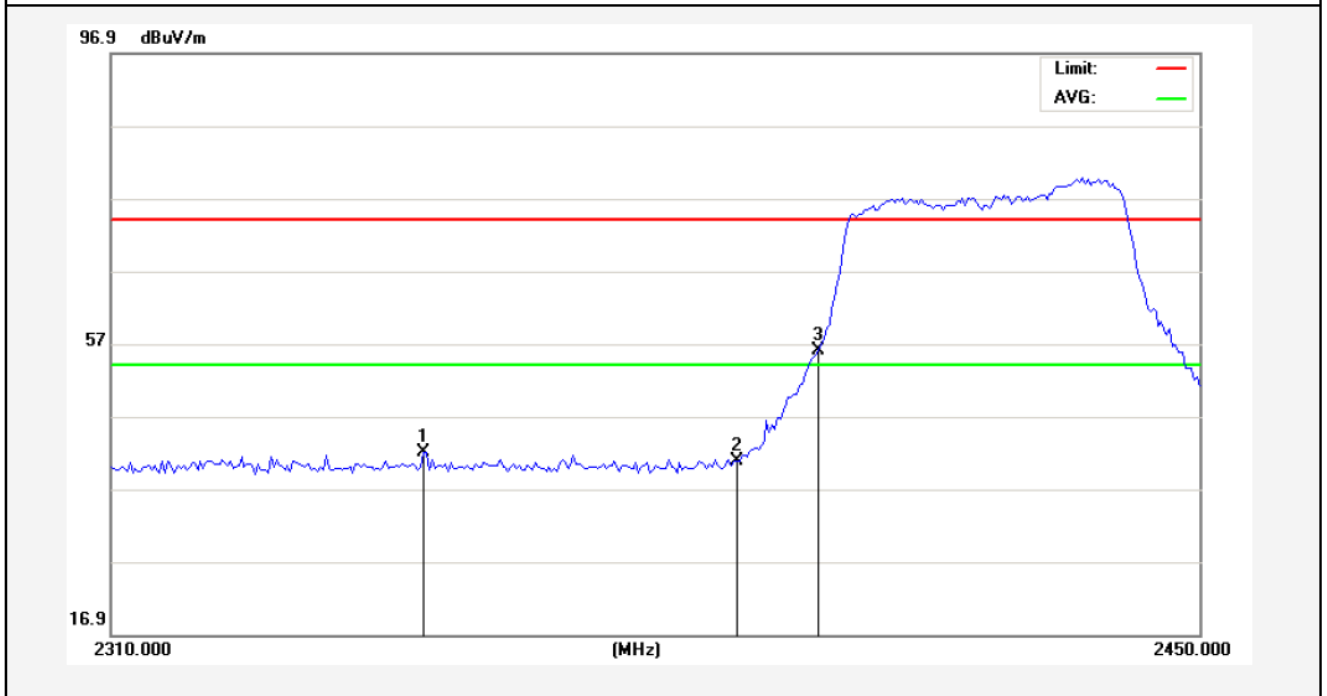

No.	Freq. (MHz)	Reading (dBuV/m)	Factor (dB/m)	Result (dBuV/m)	Limit (dBuV/)	Over Limit (dB)	Detector	Height (cm)	degree (deg)	Remark
1	2349.550	44.67	-2.60	42.07	74.00	-31.93	peak			
2	2390.000	43.27	-2.51	40.76	74.00	-33.24	peak			
3	2400.000	58.43	-2.49	55.94	74.00	-18.06	peak			

Anbotek

Vertical-AV:

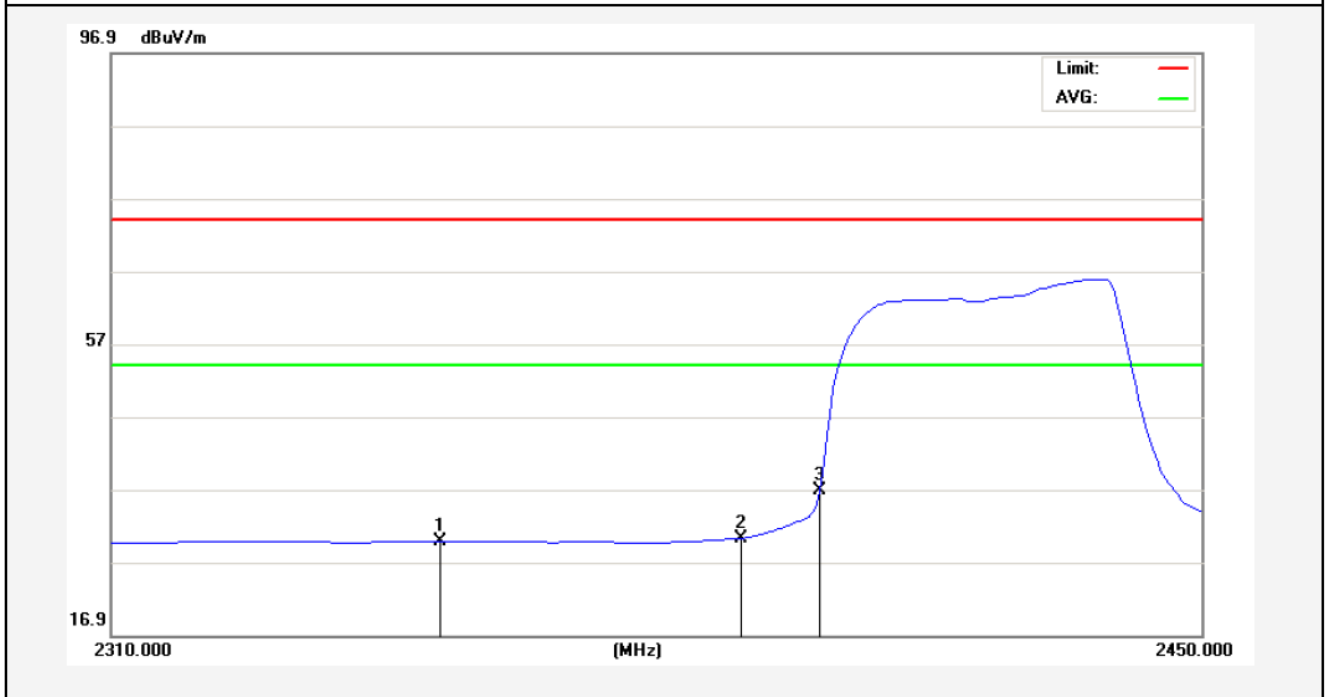

No.	Freq. (MHz)	Reading (dBuV/m)	Factor (dB/m)	Result (dBuV/m)	Limit (dBuV/)	Over Limit (dB)	Detector	Height (cm)	degree (deg)	Remark
1	2351.650	32.41	-2.60	29.81	54.00	-24.19	AVG			
2	2390.000	32.76	-2.51	30.25	54.00	-23.75	AVG			
3	2400.000	39.36	-2.49	36.87	54.00	-17.13	AVG			

Anbotek

Test Mode: 802.11n (HT40)

2452MHz

Horizontal-PEAK:

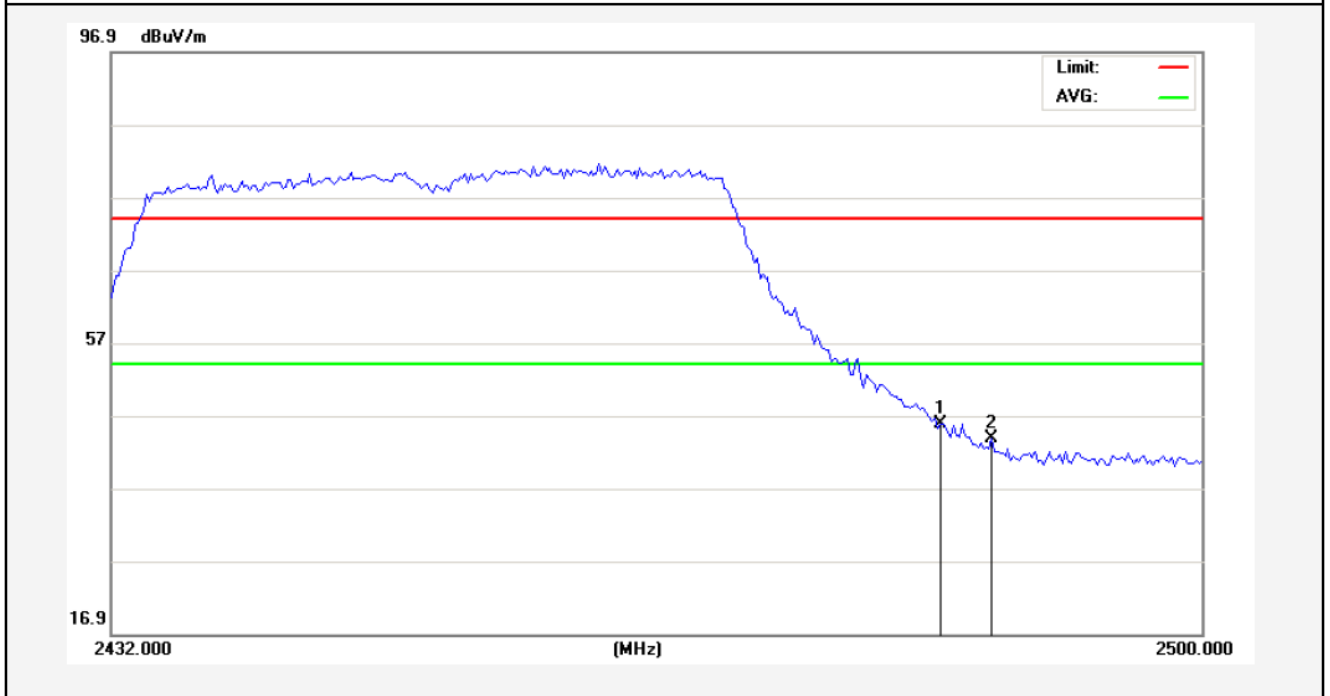

No.	Freq. (MHz)	Reading (dBuV/m)	Factor (dB/m)	Result (dBuV/m)	Limit (dBuV/)	Over Limit (dB)	Detector	Height (cm)	degree (deg)	Remark
1	2483.500	48.08	-2.31	45.77	74.00	-28.23	peak			
2	2486.910	46.15	-2.30	43.85	74.00	-30.15	peak			

Anbotek

Horizontal-AV:

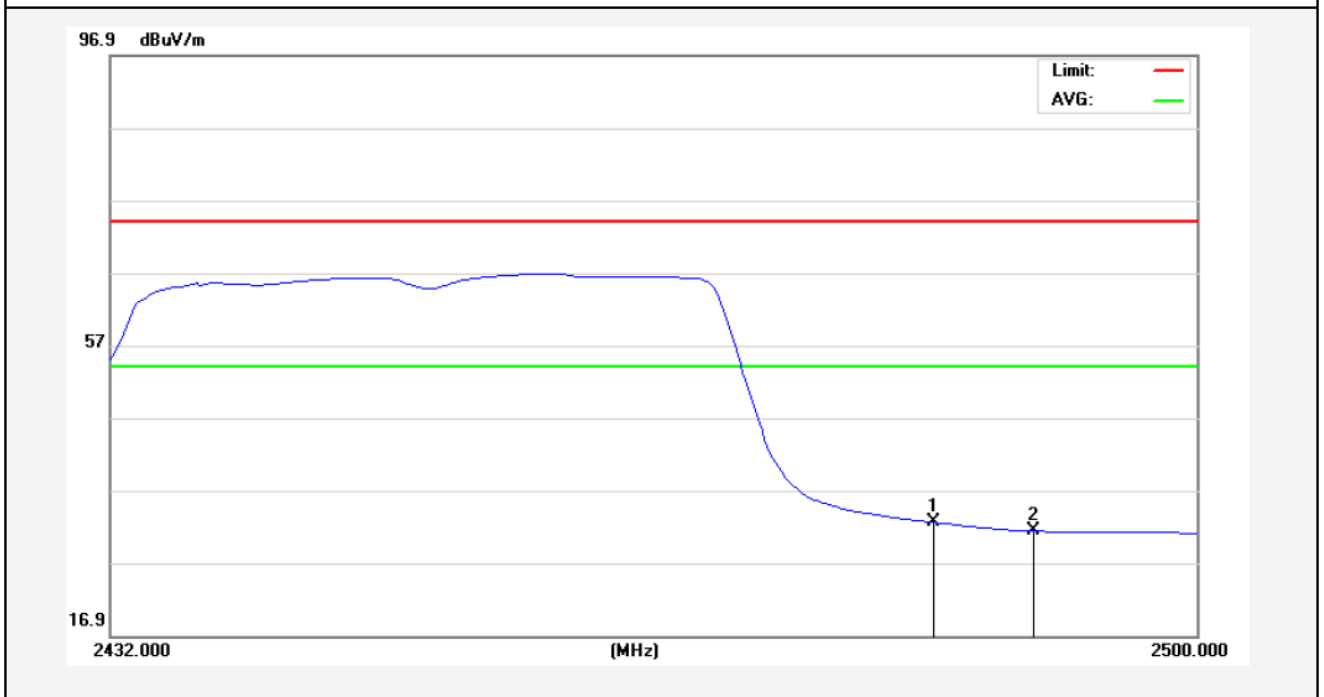

No.	Freq. (MHz)	Reading (dBuV/m)	Factor (dB/m)	Result (dBuV/m)	Limit (dBuV/)	Over Limit (dB)	Detector	Height (cm)	degree (deg)	Remark
1	2483.500	34.85	-2.31	32.54	54.00	-21.46	AVG			
2	2489.800	33.66	-2.29	31.37	54.00	-22.63	AVG			

Anbotek

Test Mode: 802.11n (HT40)

2452MHz

Vertical-PEAK:

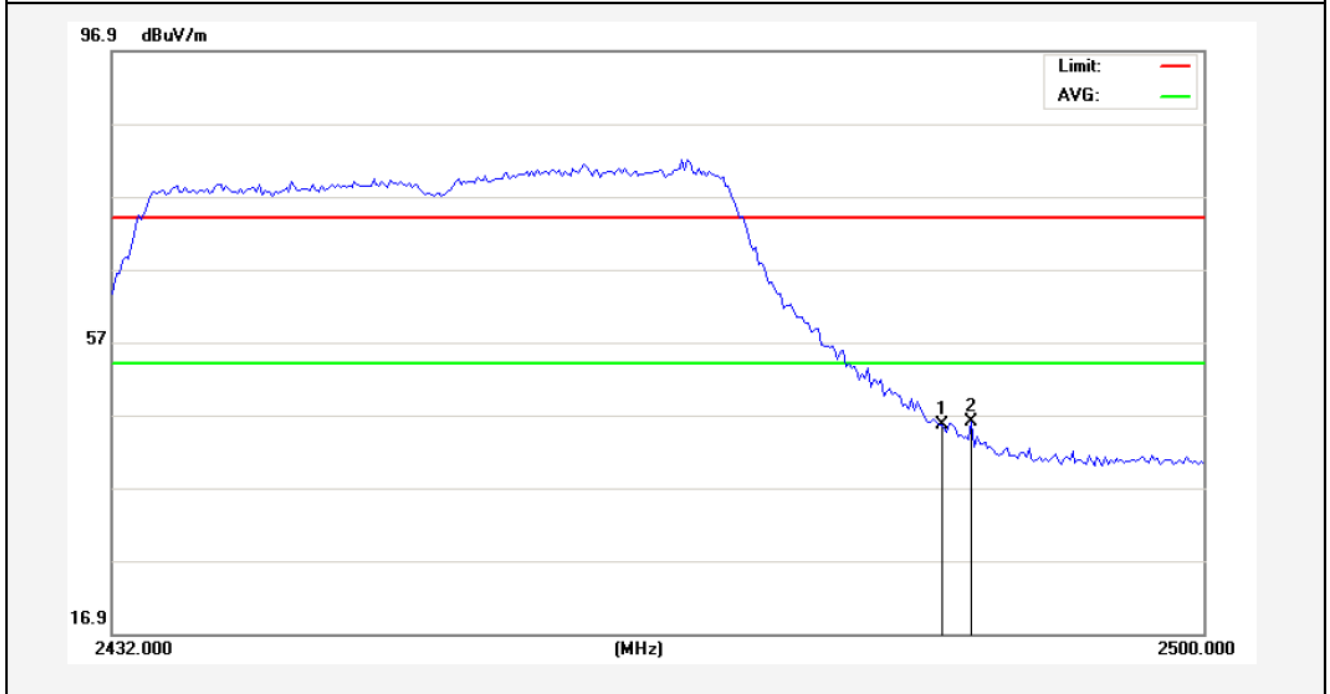

No.	Freq. (MHz)	Reading (dBuV/m)	Factor (dB/m)	Result (dBuV/m)	Limit (dBuV/)	Over Limit (dB)	Detector	Height (cm)	degree (deg)	Remark
1	2483.500	47.94	-2.31	45.63	74.00	-28.37	peak			
2	2485.550	48.29	-2.30	45.99	74.00	-28.01	peak			

Anbotek

Vertical-AV:

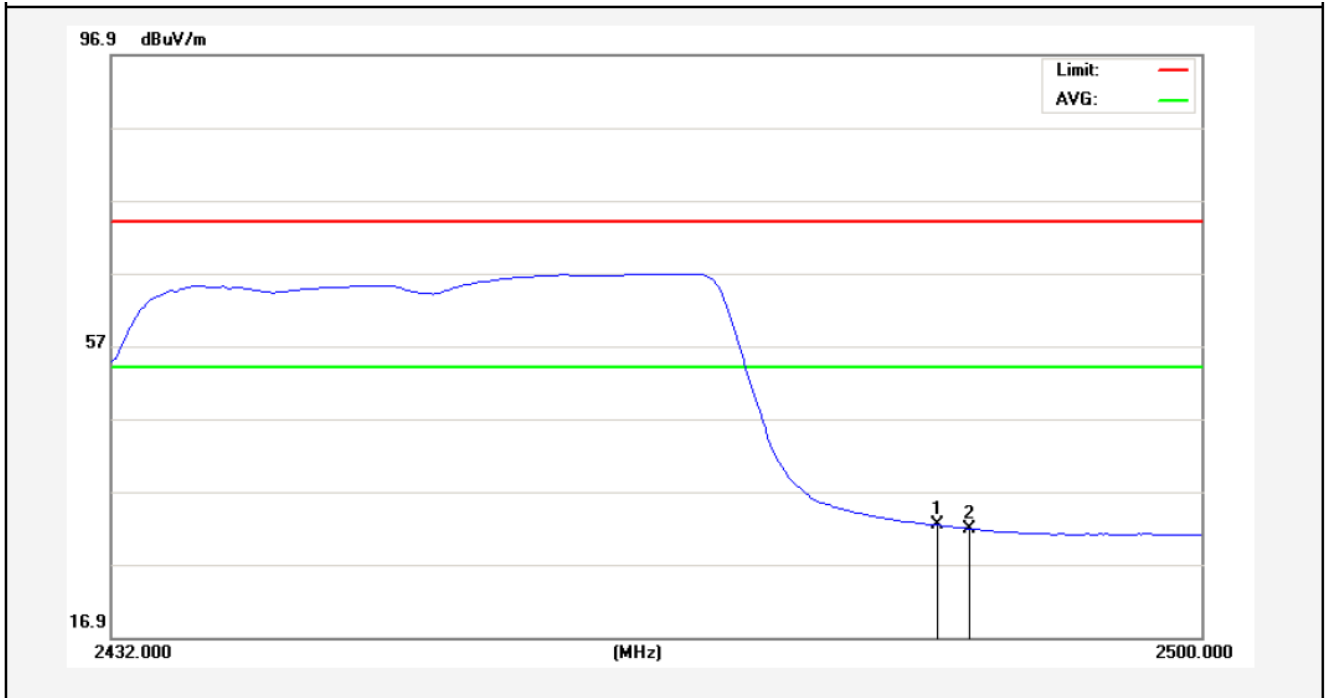

No.	Freq. (MHz)	Reading (dBuV/m)	Factor (dB/m)	Result (dBuV/m)	Limit (dBuV/)	Over Limit (dB)	Detector	Height (cm)	degree (deg)	Remark
1	2483.500	34.64	-2.31	32.33	54.00	-21.67	AVG			
2	2485.550	34.16	-2.30	31.86	54.00	-22.14	AVG			

Anbotek

ANT B

Test Mode: 802.11b

2412MHz

Horizontal-PEAK:

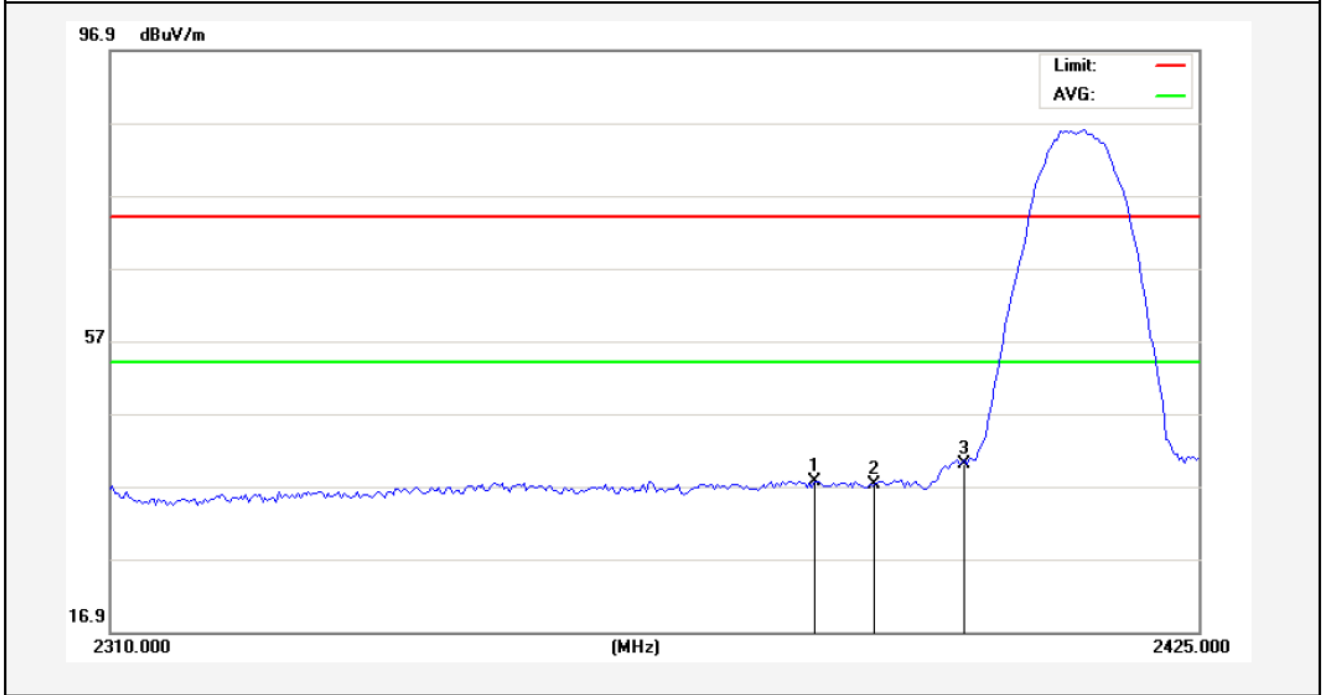

No.	Freq. (MHz)	Reading (dBuV/m)	Factor (dB/m)	Result (dBuV/m)	Limit (dBuV/)	Over Limit (dB)	Detector	Height (cm)	degree (deg)	Remark
1	2383.887	40.22	-2.53	37.69	74.00	-36.31	peak			
2	2390.000	39.65	-2.51	37.14	74.00	-36.86	peak			
3	2400.000	42.50	-2.49	40.01	74.00	-33.99	peak			

ANT B

Horizontal-AV:

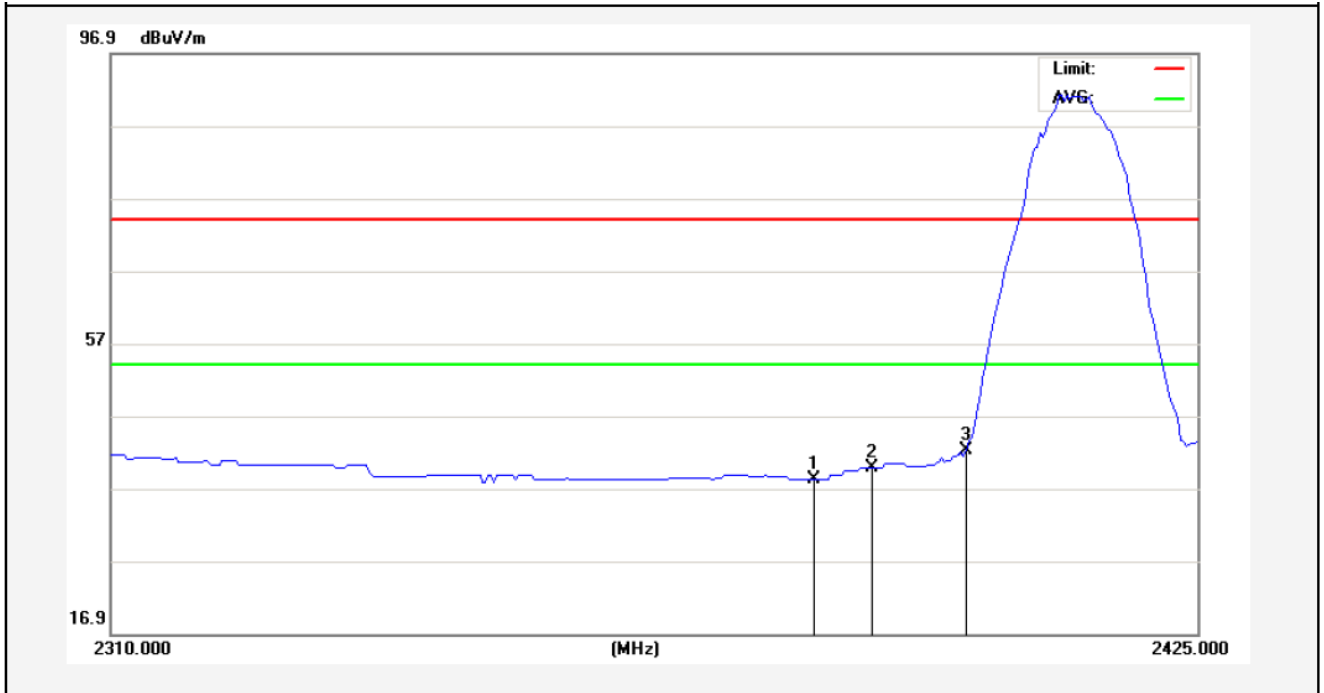

No.	Freq. (MHz)	Reading (dBuV/m)	Factor (dB/m)	Result (dBuV/m)	Limit (dBuV/)	Over Limit (dB)	Detector	Height (cm)	degree (deg)	Remark
1	2383.887	40.81	-2.53	38.28	54.00	-15.72	AVG			
2	2390.000	42.35	-2.51	39.84	54.00	-14.16	AVG			
3	2400.000	44.68	-2.49	42.19	54.00	-11.81	AVG			

Anbotek

Test Mode: 802.11b
2412MHz
Vertical-PEAK:

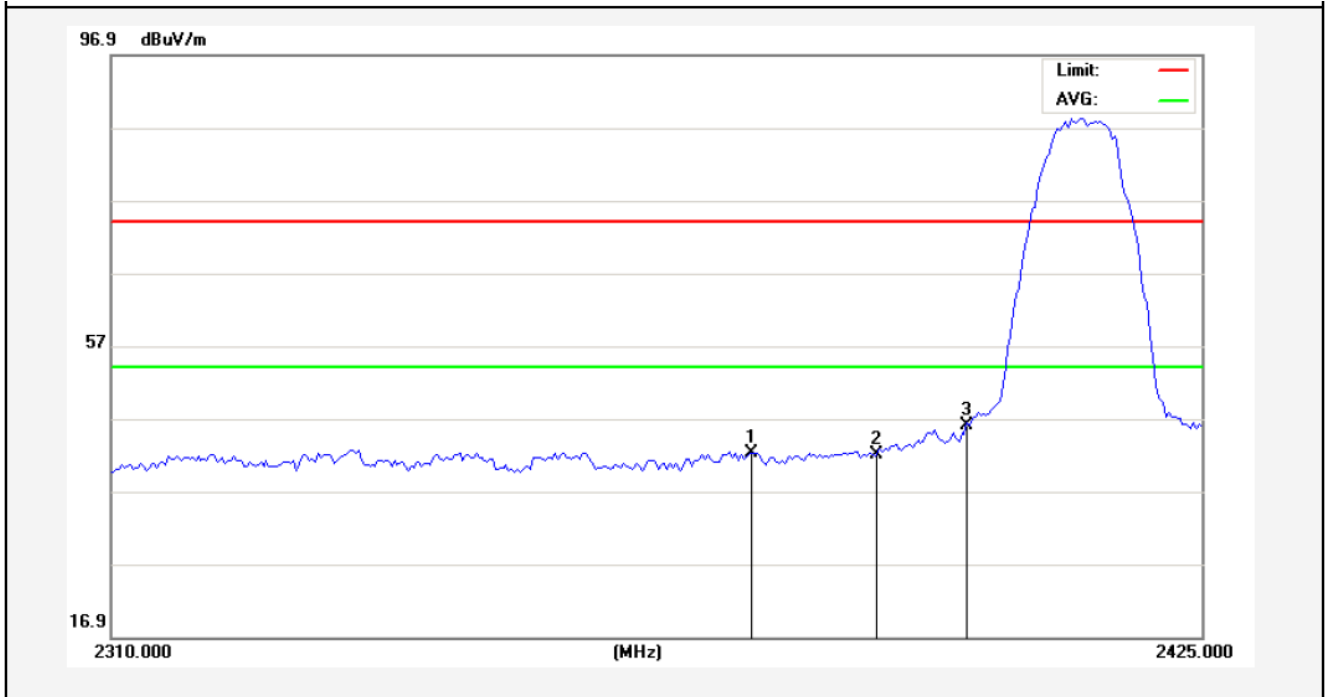

No.	Freq. (MHz)	Reading (dBuV/m)	Factor (dB/m)	Result (dBuV/m)	Limit (dBuV/)	Over Limit (dB)	Detector	Height (cm)	degree (deg)	Remark
1	2376.988	44.84	-2.54	42.30	74.00	-31.70	peak			
2	2390.000	44.48	-2.51	41.97	74.00	-32.03	peak			
3	2400.000	48.42	-2.49	45.93	74.00	-28.07	peak			

Anbotek

Vertical-AV:

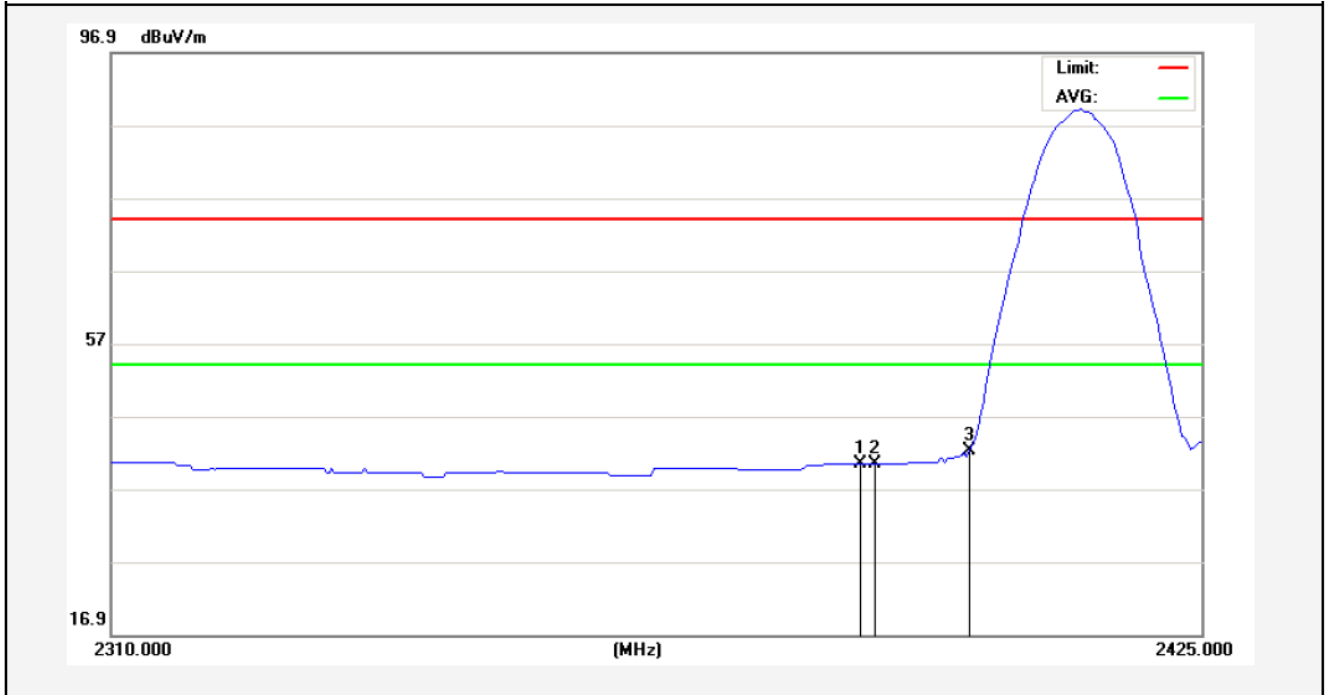

No.	Freq. (MHz)	Reading (dBuV/m)	Factor (dB/m)	Result (dBuV/m)	Limit (dBuV/)	Over Limit (dB)	Detector	Height (cm)	degree (deg)	Remark
1	2388.488	42.86	-2.52	40.34	54.00	-13.66	AVG			
2	2390.000	42.85	-2.51	40.34	54.00	-13.66	AVG			
3	2400.000	44.70	-2.49	42.21	54.00	-11.79	AVG			

Anbotek

Test Mode: 802.11b
2462MHz
Horizontal-PEAK:

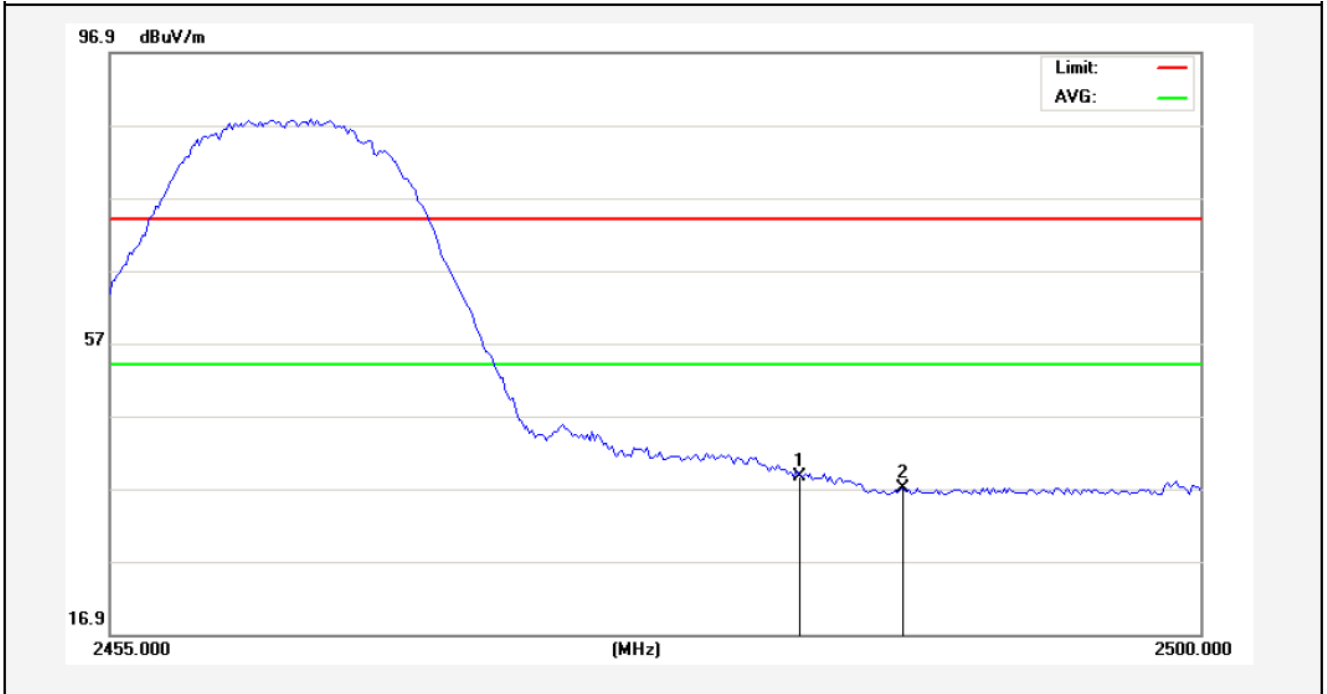

No.	Freq. (MHz)	Reading (dBuV/m)	Factor (dB/m)	Result (dBuV/m)	Limit (dBuV/)	Over Limit (dB)	Detector	Height (cm)	degree (deg)	Remark
1	2483.500	41.00	-2.31	38.69	74.00	-35.31	peak			
2	2487.738	39.36	-2.30	37.06	74.00	-36.94	peak			

Anbotek

Horizontal-AV:

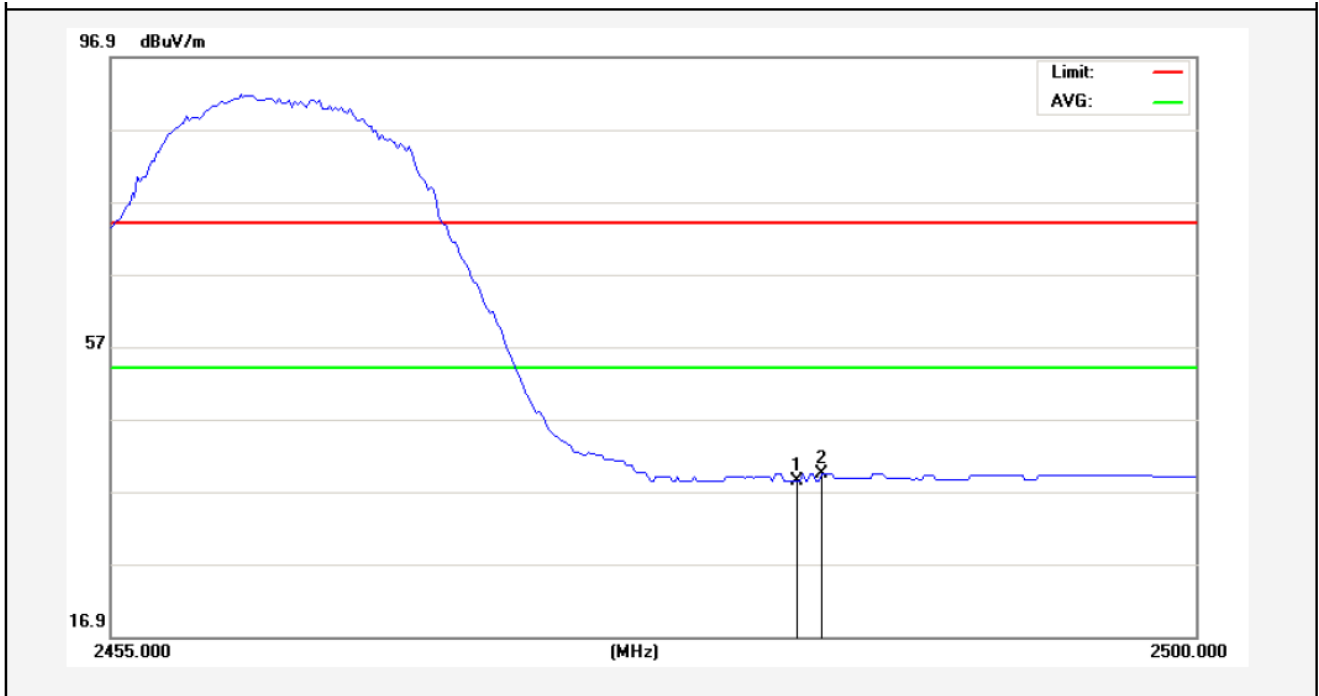

No.	Freq. (MHz)	Reading (dBuV/m)	Factor (dB/m)	Result (dBuV/m)	Limit (dBuV/)	Over Limit (dB)	Detector	Height (cm)	degree (deg)	Remark
1	2483.500	40.72	-2.31	38.41	54.00	-15.59	AVG			
2	2484.475	41.70	-2.30	39.40	54.00	-14.60	AVG			

Anbotek

Test Mode: 802.11b
2462MHz
Vertical-PEAK:

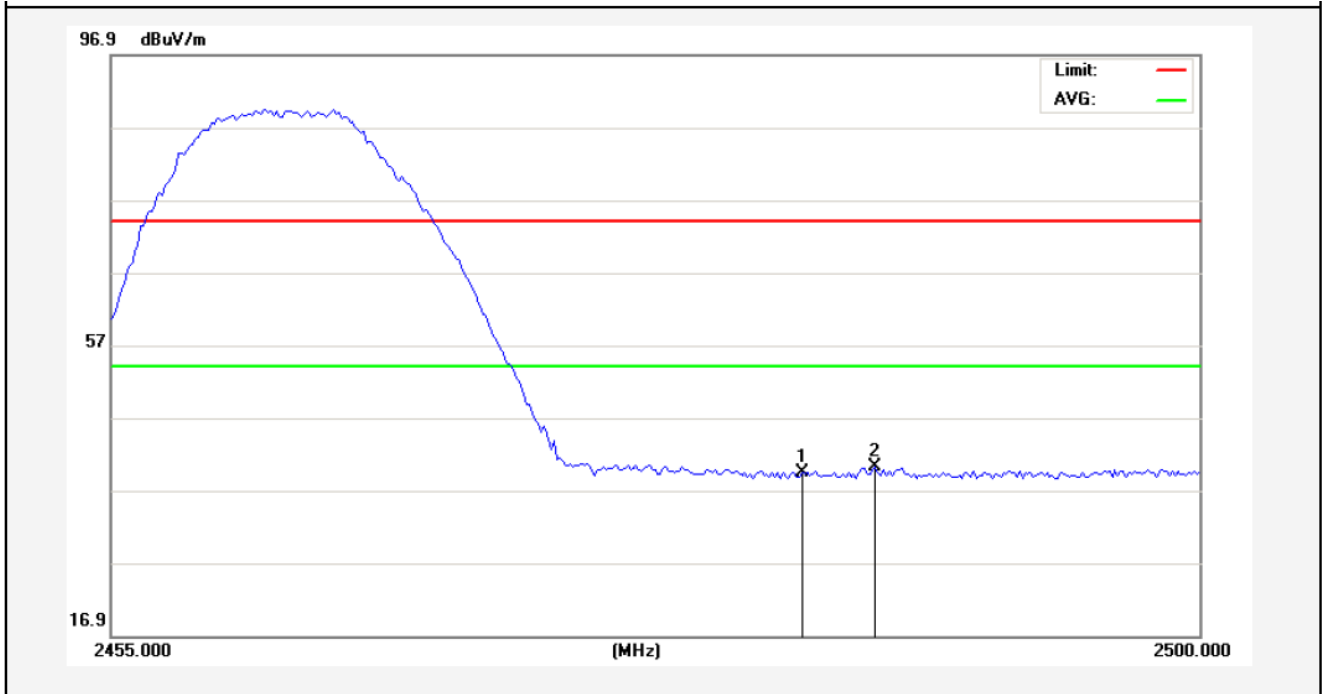

No.	Freq. (MHz)	Reading (dBuV/m)	Factor (dB/m)	Result (dBuV/m)	Limit (dBuV/)	Over Limit (dB)	Detector	Height (cm)	degree (deg)	Remark
1	2483.500	41.69	-2.31	39.38	74.00	-34.62	peak			
2	2486.613	42.53	-2.30	40.23	74.00	-33.77	peak			

Anbotek

Vertical-AV:

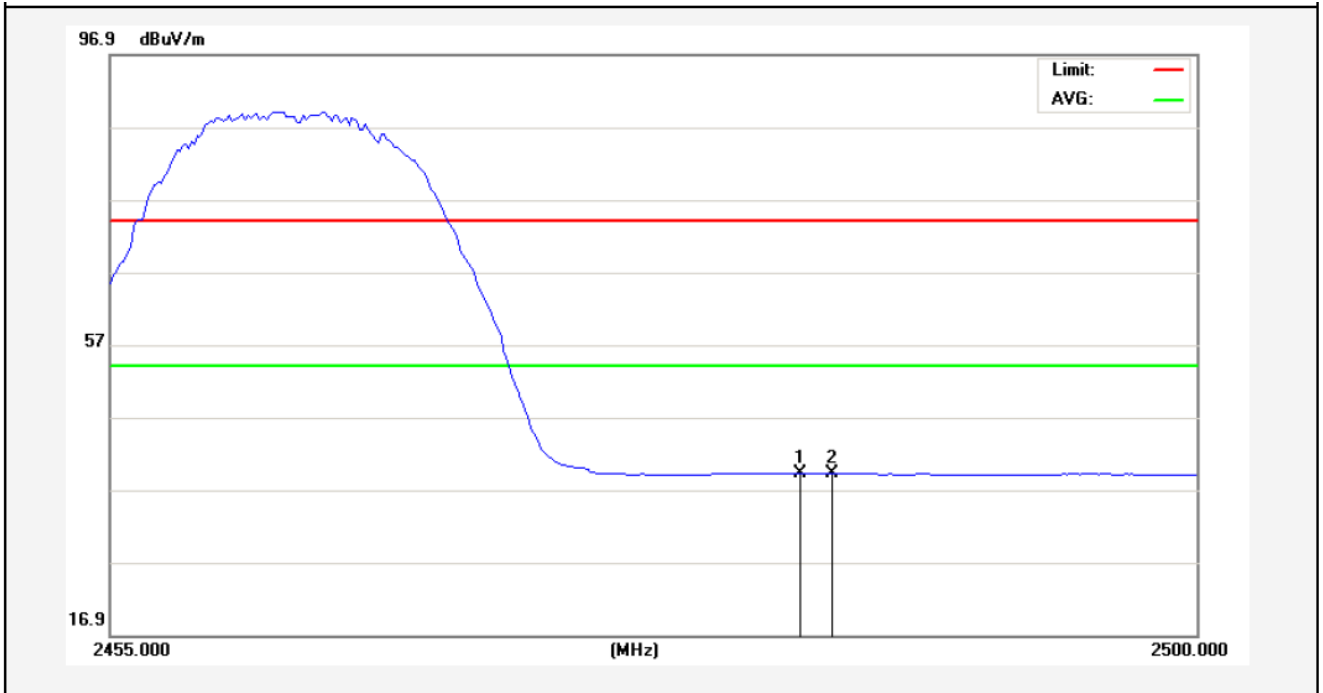

No.	Freq. (MHz)	Reading (dBuV/m)	Factor (dB/m)	Result (dBuV/m)	Limit (dBuV/)	Over Limit (dB)	Detector	Height (cm)	degree (deg)	Remark
1	2483.500	41.47	-2.31	39.16	54.00	-14.84	AVG			
2	2484.925	41.46	-2.30	39.16	54.00	-14.84	AVG			

Anbotek

Test Mode: 802.11g
2412MHz
Horizontal-PEAK:

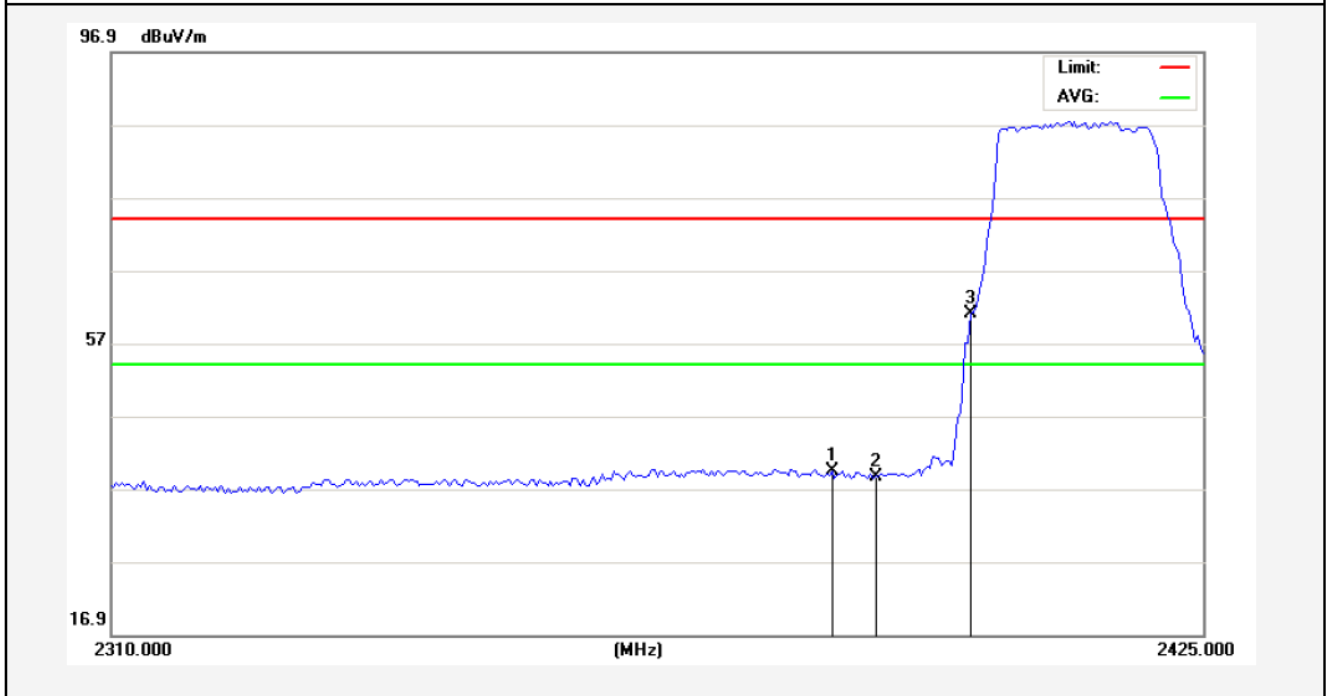

No.	Freq. (MHz)	Reading (dBuV/m)	Factor (dB/m)	Result (dBuV/m)	Limit (dBuV/)	Over Limit (dB)	Detector	Height (cm)	degree (deg)	Remark
1	2385.325	41.92	-2.52	39.40	74.00	-34.60	peak			
2	2390.000	41.11	-2.51	38.60	74.00	-35.40	peak			
3	2400.000	63.40	-2.49	60.91	74.00	-13.09	peak			

Anbotek

Horizontal-AV:

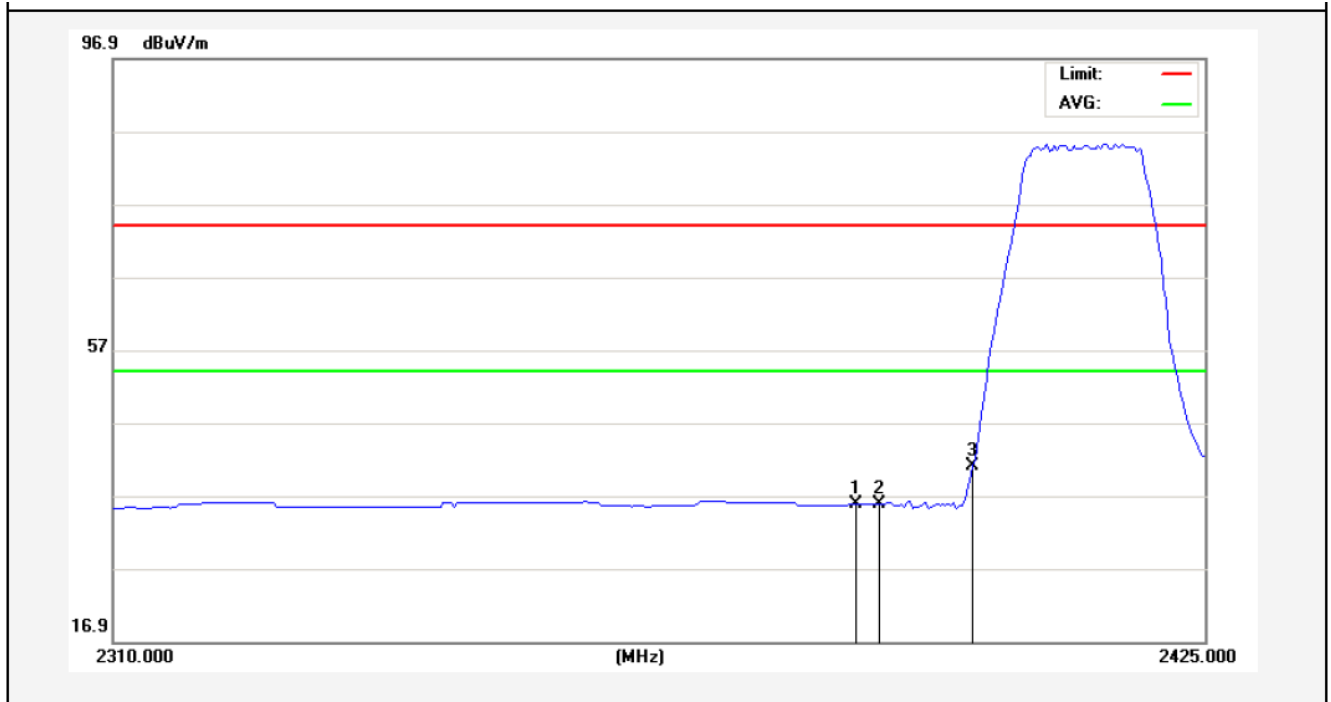

No.	Freq. (MHz)	Reading (dBuV/m)	Factor (dB/m)	Result (dBuV/m)	Limit (dBuV/)	Over Limit (dB)	Detector	Height (cm)	degree (deg)	Remark
1	2387.625	38.26	-2.52	35.74	54.00	-18.26	AVG			
2	2390.000	38.32	-2.51	35.81	54.00	-18.19	AVG			
3	2400.000	43.56	-2.49	41.07	54.00	-12.93	AVG			

Anbotek

Test Mode: 802.11g
2412MHz
Vertical-PEAK:

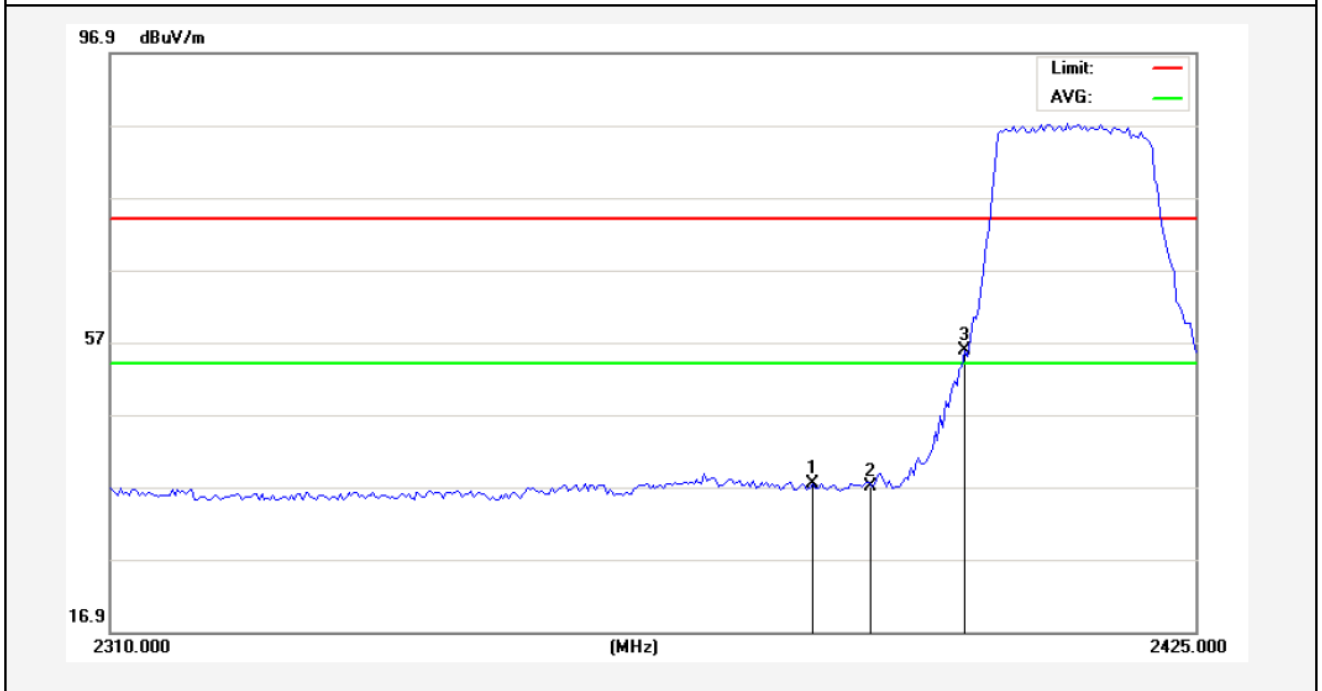

No.	Freq. (MHz)	Reading (dBuV/m)	Factor (dB/m)	Result (dBuV/m)	Limit (dBuV/)	Over Limit (dB)	Detector	Height (cm)	degree (deg)	Remark
1	2383.887	40.02	-2.53	37.49	74.00	-36.51	peak			
2	2390.000	39.57	-2.51	37.06	74.00	-36.94	peak			
3	2400.000	58.36	-2.49	55.87	74.00	-18.13	peak			

AMB

Vertical-AV:

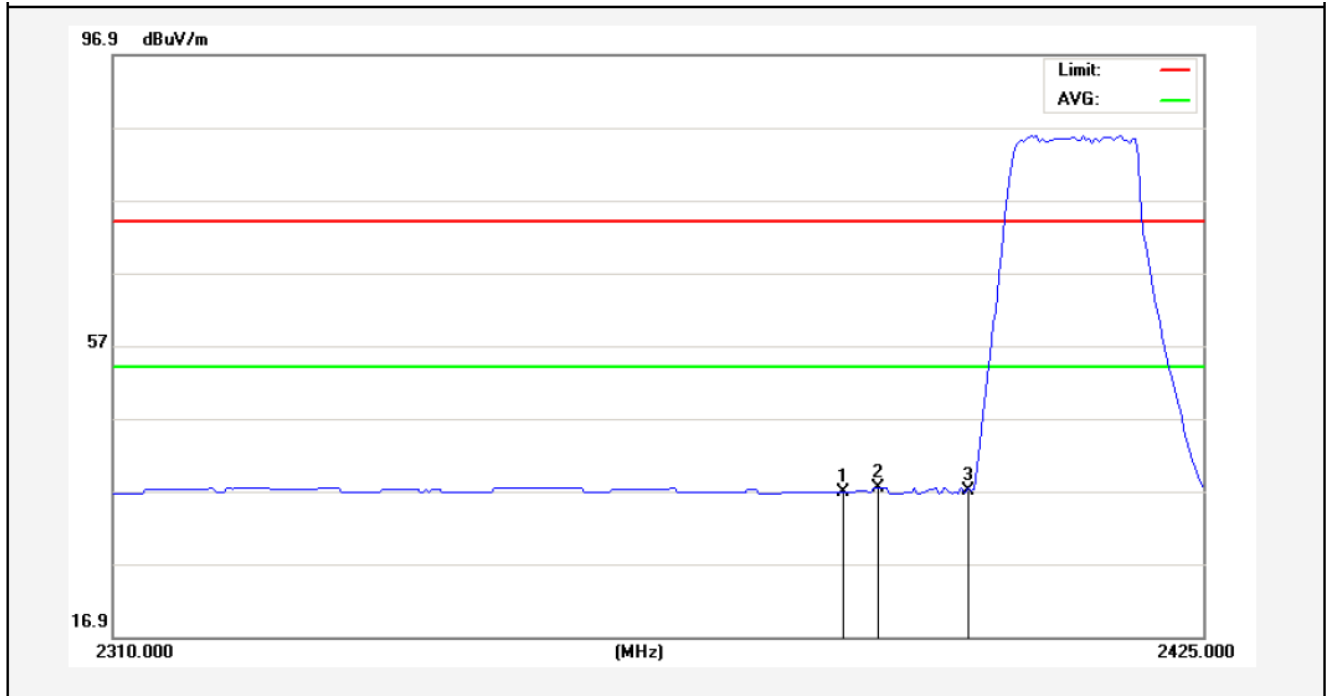

No.	Freq. (MHz)	Reading (dBuV/m)	Factor (dB/m)	Result (dBuV/m)	Limit (dBuV/)	Over Limit (dB)	Detector	Height (cm)	degree (deg)	Remark
1	2386.475	39.39	-2.52	36.87	54.00	-17.13	AVG			
2	2390.000	39.94	-2.51	37.43	54.00	-16.57	AVG			
3	2400.000	39.45	-2.49	36.96	54.00	-17.04	AVG			

Anbotek

Test Mode: 802.11g
2462MHz
Horizontal-PEAK:

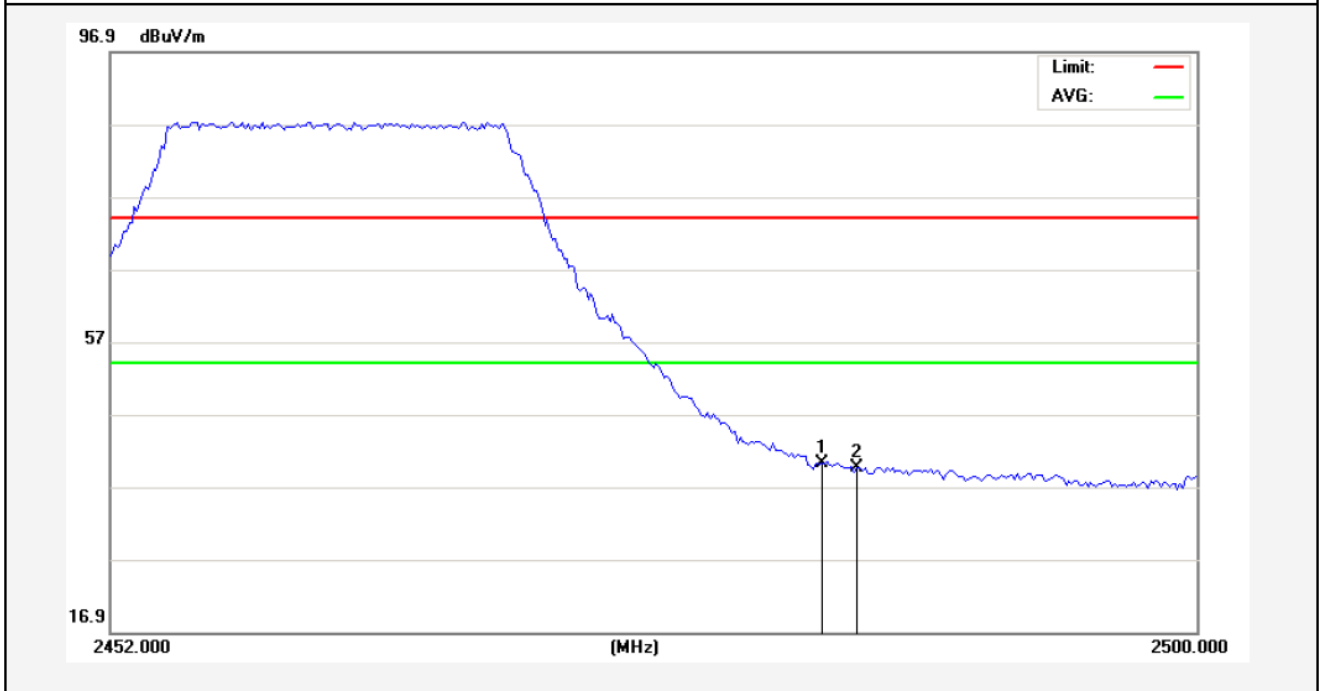

No.	Freq. (MHz)	Reading (dBuV/m)	Factor (dB/m)	Result (dBuV/m)	Limit (dBuV/)	Over Limit (dB)	Detector	Height (cm)	degree (deg)	Remark
1	2483.500	42.54	-2.31	40.23	74.00	-33.77	peak			
2	2485.000	41.99	-2.30	39.69	74.00	-34.31	peak			

Anbotek

Horizontal-AV:

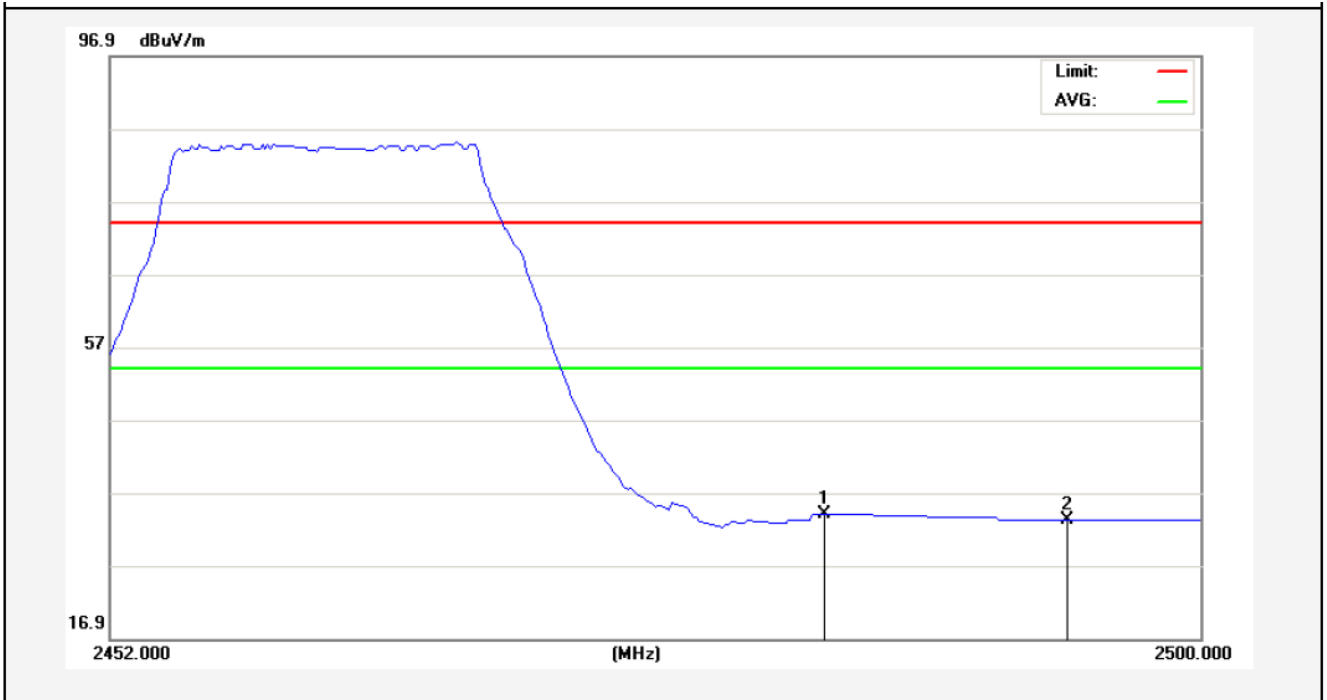

No.	Freq. (MHz)	Reading (dBuV/m)	Factor (dB/m)	Result (dBuV/m)	Limit (dBuV/)	Over Limit (dB)	Detector	Height (cm)	degree (deg)	Remark
1	2483.500	36.35	-2.31	34.04	54.00	-19.96	AVG			
2	2494.120	35.54	-2.28	33.26	54.00	-20.74	AVG			

Anbotek

Test Mode: 802.11g
2462MHz
Vertical-PEAK:

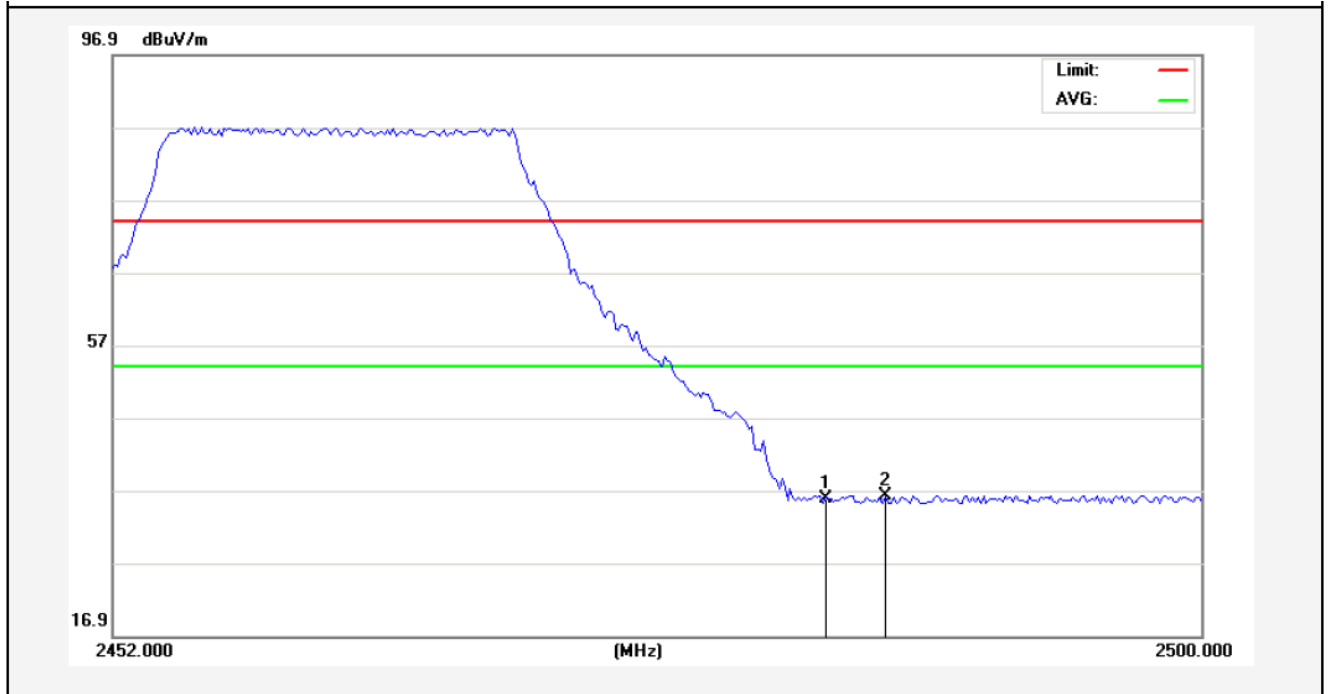

No.	Freq. (MHz)	Reading (dBuV/m)	Factor (dB/m)	Result (dBuV/m)	Limit (dBuV/)	Over Limit (dB)	Detector	Height (cm)	degree (deg)	Remark
1	2483.500	38.14	-2.31	35.83	74.00	-38.17	peak			
2	2486.080	38.47	-2.30	36.17	74.00	-37.83	peak			

Anbotek

Vertical-AV:

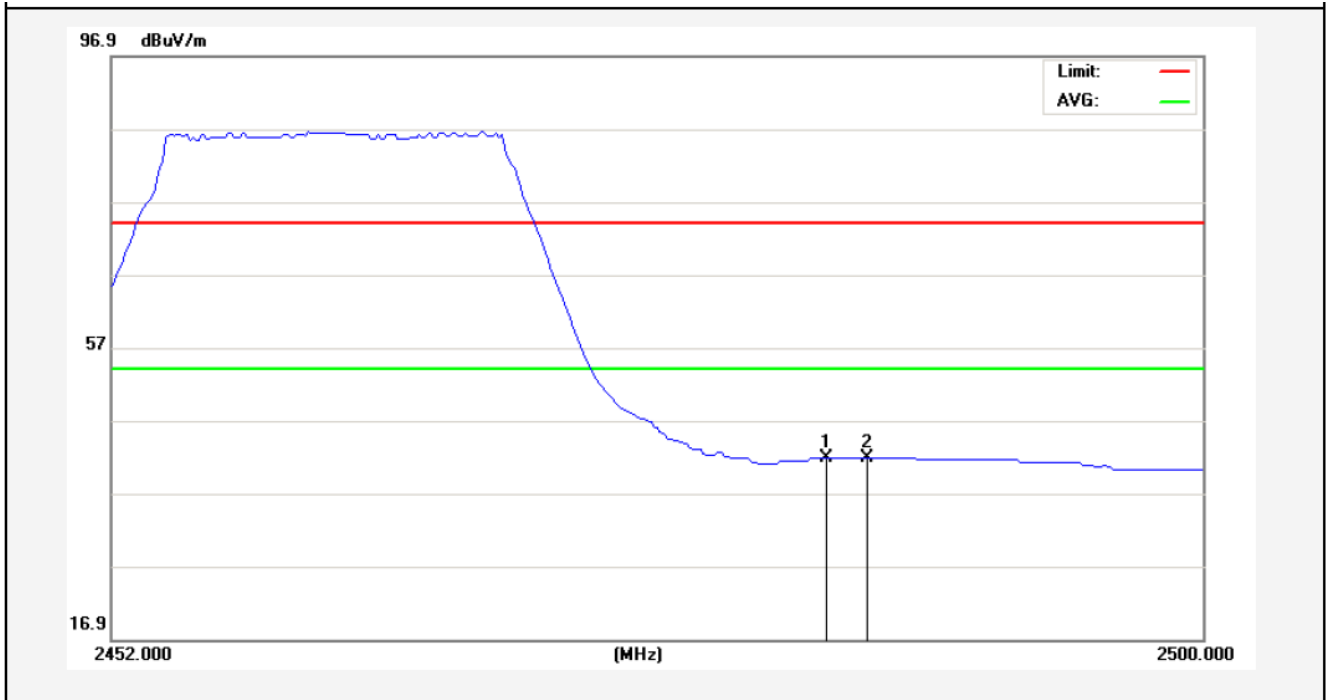

No.	Freq. (MHz)	Reading (dBuV/m)	Factor (dB/m)	Result (dBuV/m)	Limit (dBuV/)	Over Limit (dB)	Detector	Height (cm)	degree (deg)	Remark
1	2483.500	44.17	-2.31	41.86	54.00	-12.14	AVG			
2	2485.240	44.10	-2.30	41.80	54.00	-12.20	AVG			

Anbotek

Test Mode: 802.11n (HT20)

2412MHz

Horizontal-PEAK:

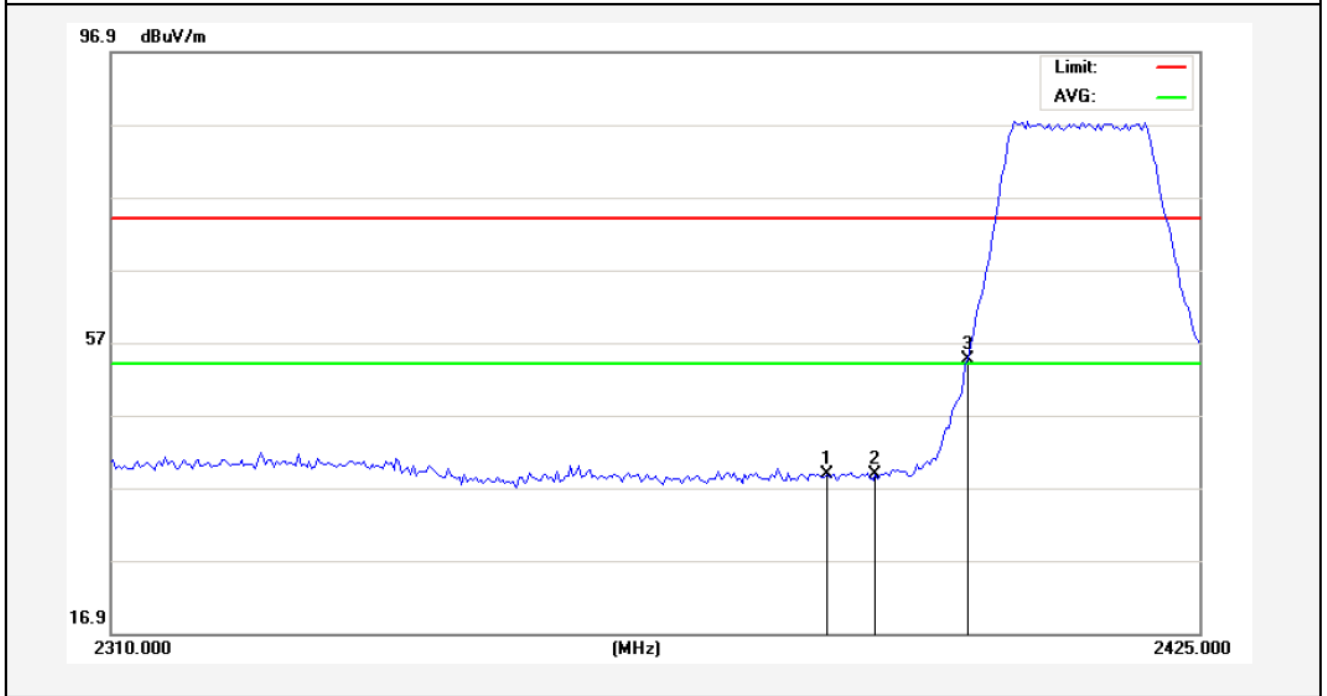

No.	Freq. (MHz)	Reading (dBuV/m)	Factor (dB/m)	Result (dBuV/m)	Limit (dBuV/)	Over Limit (dB)	Detector	Height (cm)	degree (deg)	Remark
1	2385.037	41.40	-2.53	38.87	74.00	-35.13	peak			
2	2390.000	41.35	-2.51	38.84	74.00	-35.16	peak			
3	2400.000	57.15	-2.49	54.66	74.00	-19.34	peak			

Anbotek

Horizontal-AV:

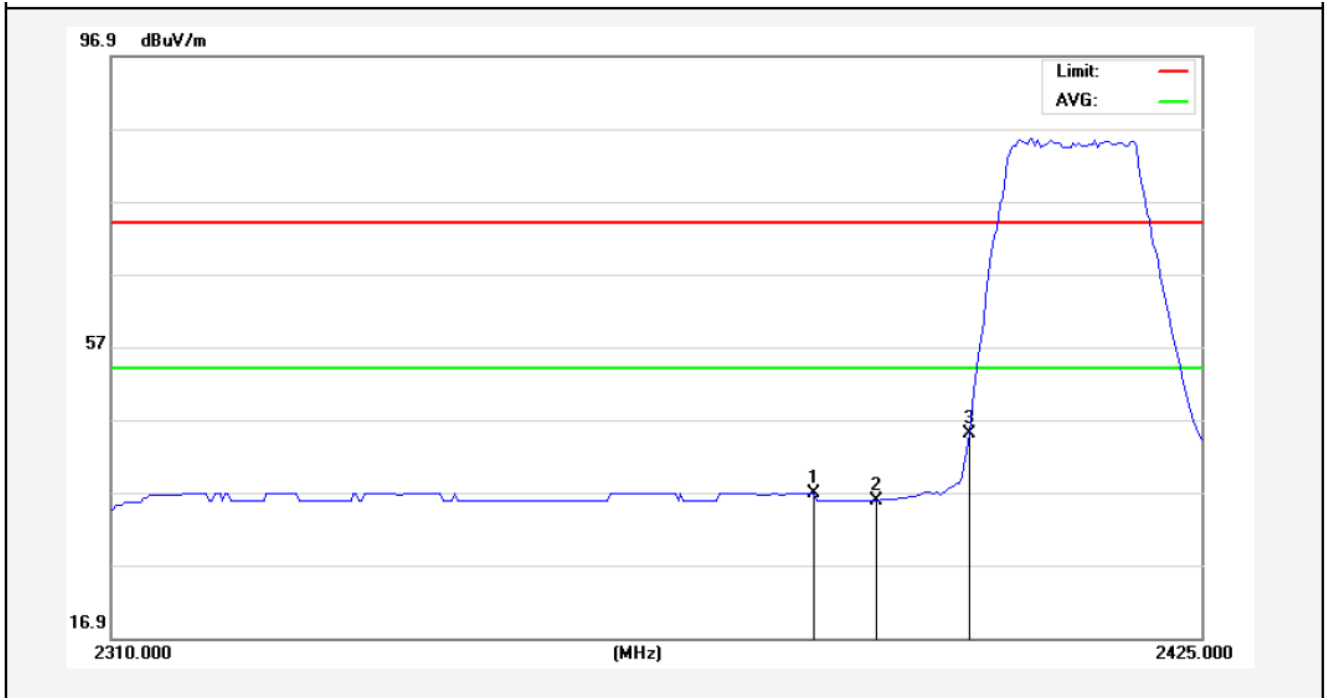

No.	Freq. (MHz)	Reading (dBuV/m)	Factor (dB/m)	Result (dBuV/m)	Limit (dBuV/)	Over Limit (dB)	Detector	Height (cm)	degree (deg)	Remark
1	2383.600	39.33	-2.53	36.80	54.00	-17.20	AVG			
2	2390.000	38.41	-2.51	35.90	54.00	-18.10	AVG			
3	2400.000	47.45	-2.49	44.96	54.00	-9.04	AVG			

Anbotek

Test Mode: 802.11n (HT20)

2412MHz

Vertical-PEAK:

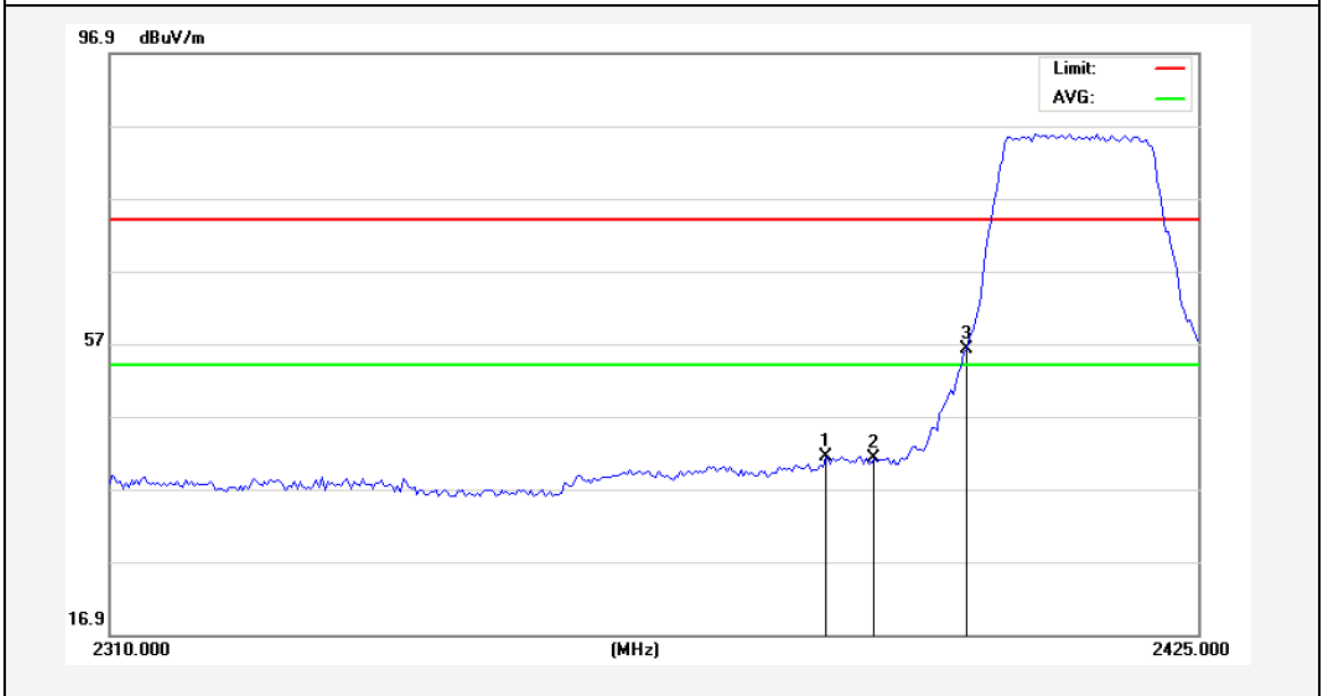

No.	Freq. (MHz)	Reading (dBuV/m)	Factor (dB/m)	Result (dBuV/m)	Limit (dBuV/)	Over Limit (dB)	Detector	Height (cm)	degree (deg)	Remark
1	2385.037	43.87	-2.53	41.34	74.00	-32.66	peak			
2	2390.000	43.70	-2.51	41.19	74.00	-32.81	peak			
3	2400.000	58.74	-2.49	56.25	74.00	-17.75	peak			

AMB

Vertical-AV:

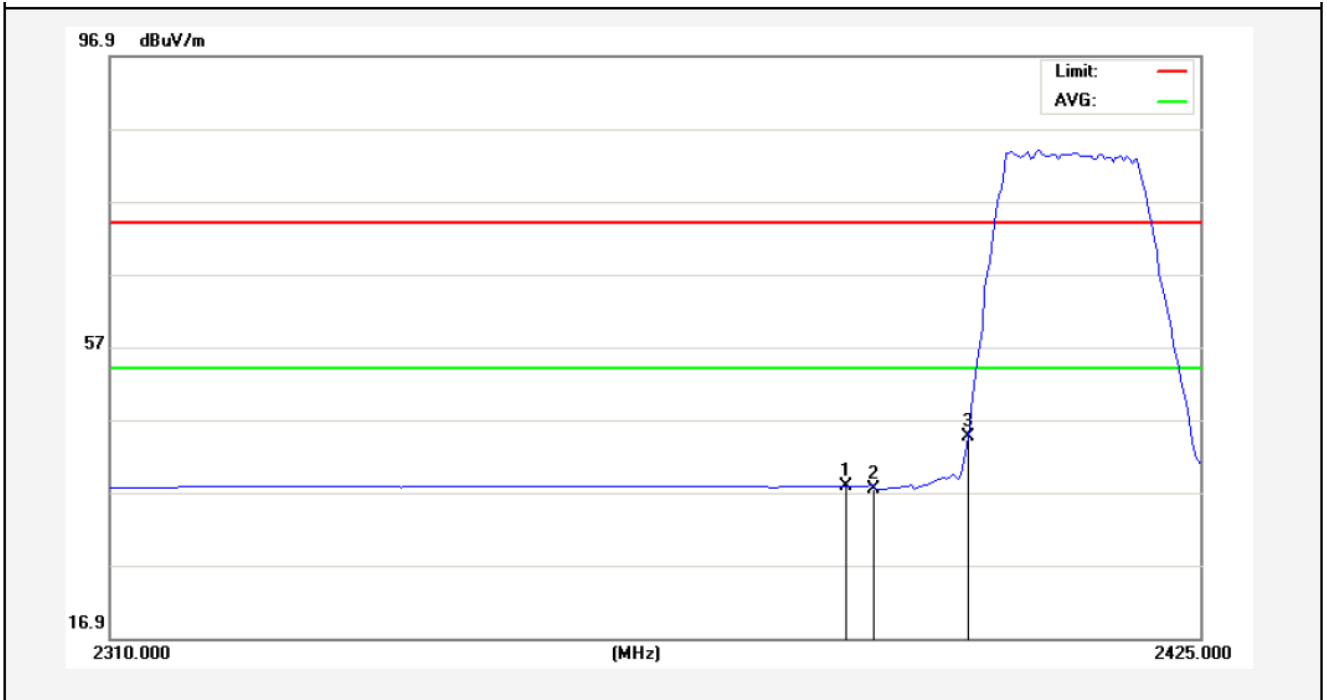

No.	Freq. (MHz)	Reading (dBuV/m)	Factor (dB/m)	Result (dBuV/m)	Limit (dBuV/)	Over Limit (dB)	Detector	Height (cm)	degree (deg)	Remark
1	2387.050	40.38	-2.52	37.86	54.00	-16.14	AVG			
2	2390.000	39.91	-2.51	37.40	54.00	-16.60	AVG			
3	2400.000	47.13	-2.49	44.64	54.00	-9.36	AVG			

Anbotek

Test Mode: 802.11n (HT20)

2462MHz

Horizontal-PEAK:

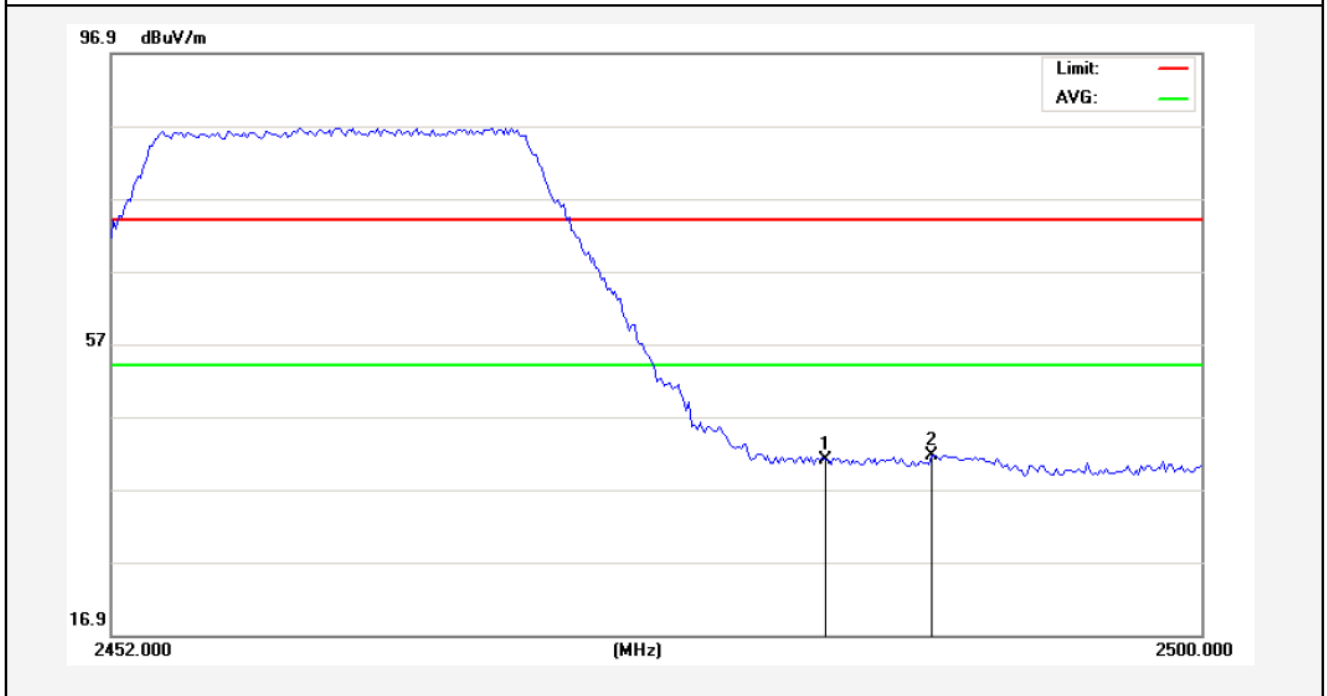

No.	Freq. (MHz)	Reading (dBuV/m)	Factor (dB/m)	Result (dBuV/m)	Limit (dBuV/)	Over Limit (dB)	Detector	Height (cm)	degree (deg)	Remark
1	2483.500	43.23	-2.31	40.92	74.00	-33.08	peak			
2	2488.120	44.00	-2.30	41.70	74.00	-32.30	peak			

Anbotek

Horizontal-AV:

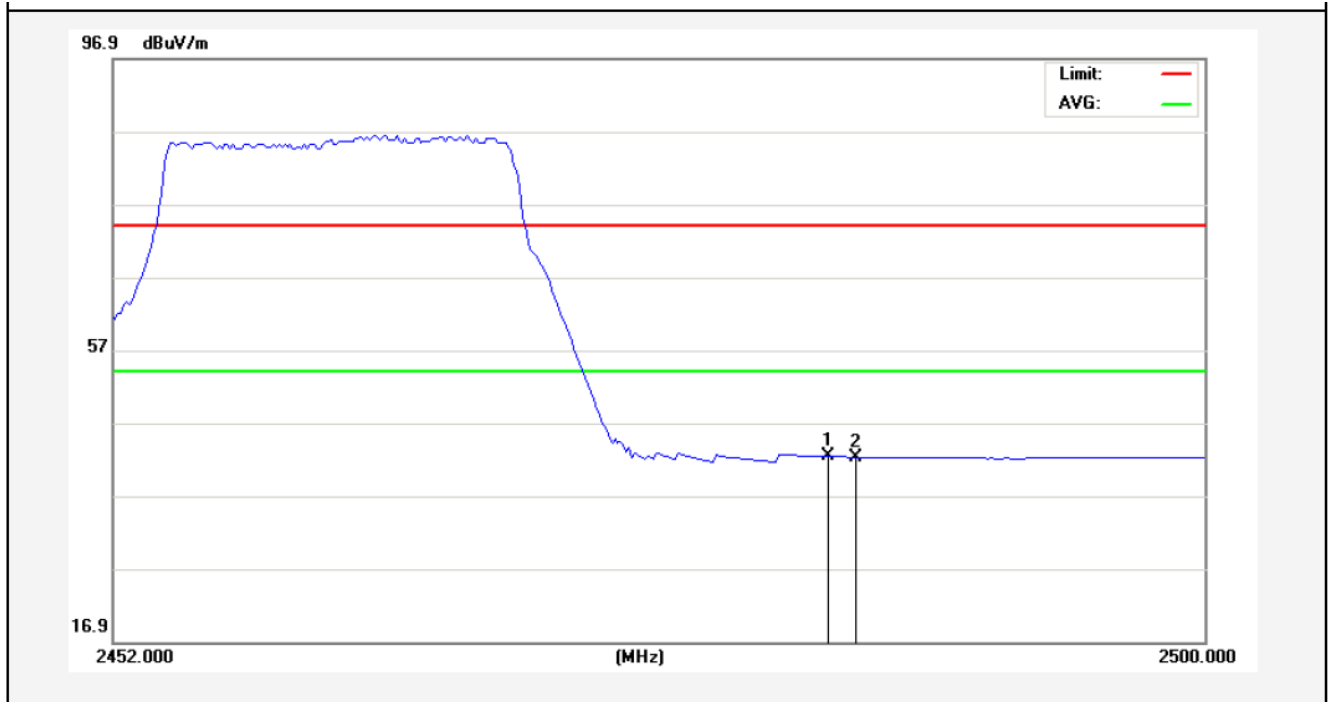

No.	Freq. (MHz)	Reading (dBuV/m)	Factor (dB/m)	Result (dBuV/m)	Limit (dBuV/)	Over Limit (dB)	Detector	Height (cm)	degree (deg)	Remark
1	2483.500	44.64	-2.31	42.33	54.00	-11.67	AVG			
2	2484.640	44.58	-2.30	42.28	54.00	-11.72	AVG			

Anbotek

Test Mode: 802.11n (HT20)

2462MHz

Vertical-PEAK:

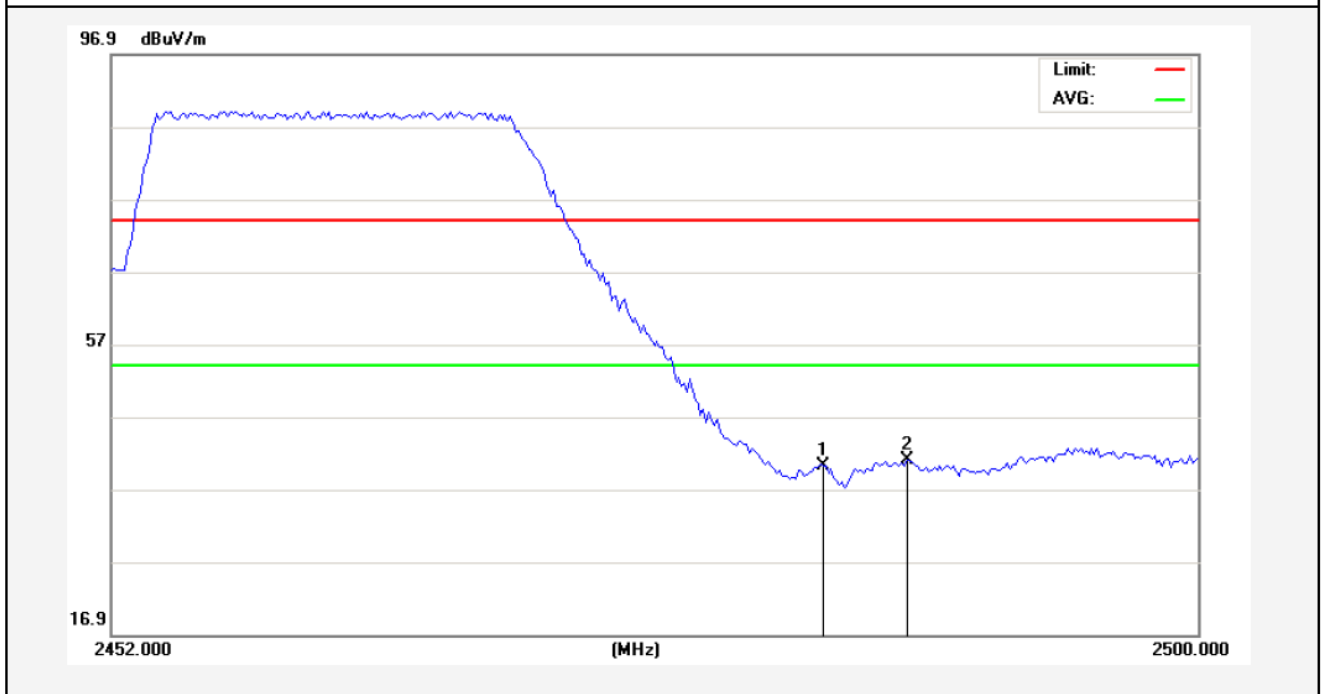

No.	Freq. (MHz)	Reading (dBuV/m)	Factor (dB/m)	Result (dBuV/m)	Limit (dBuV/)	Over Limit (dB)	Detector	Height (cm)	degree (deg)	Remark
1	2483.500	42.54	-2.31	40.23	74.00	-33.77	peak			
2	2487.160	43.22	-2.30	40.92	74.00	-33.08	peak			

Anbotek

Vertical-AV:

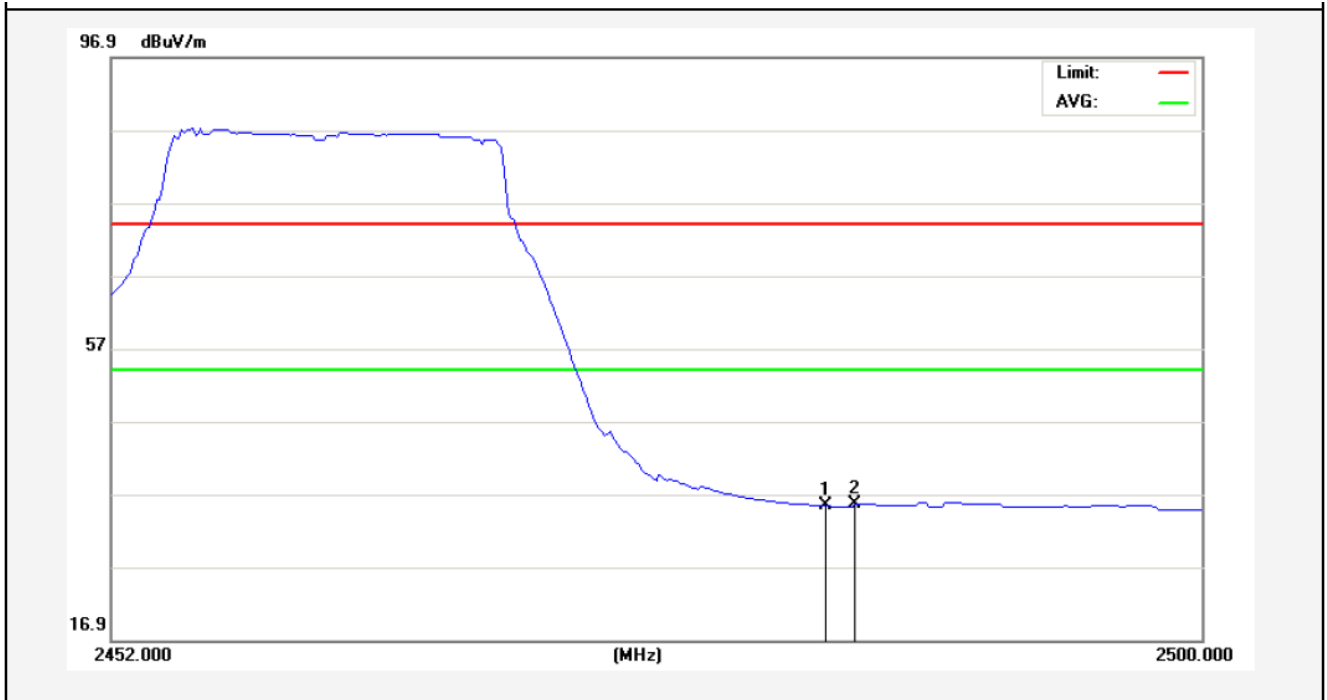

No.	Freq. (MHz)	Reading (dBuV/m)	Factor (dB/m)	Result (dBuV/m)	Limit (dBuV/)	Over Limit (dB)	Detector	Height (cm)	degree (deg)	Remark
1	2483.500	37.63	-2.31	35.32	54.00	-18.68	AVG			
2	2484.760	37.96	-2.30	35.66	54.00	-18.34	AVG			

Anbotek

Test Mode: 802.11n (HT40)

2422MHz

Horizontal-PEAK:

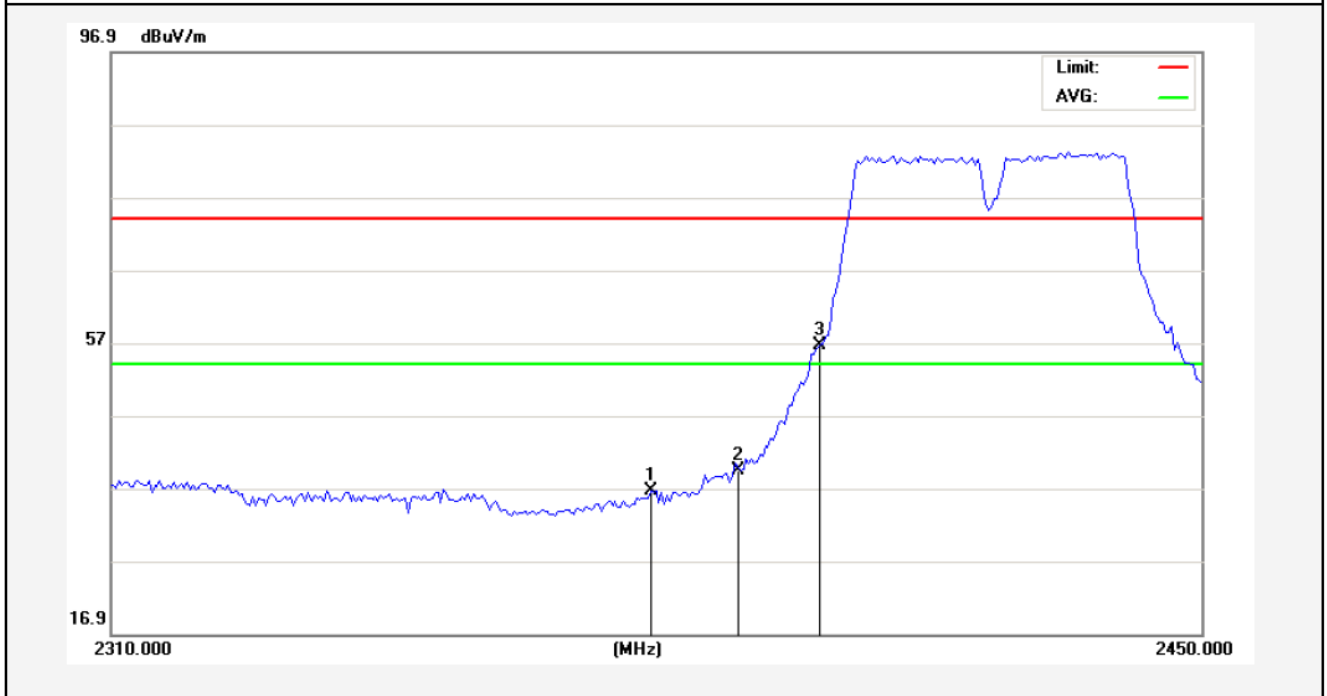

No.	Freq. (MHz)	Reading (dBuV/m)	Factor (dB/m)	Result (dBuV/m)	Limit (dBuV/)	Over Limit (dB)	Detector	Height (cm)	degree (deg)	Remark
1	2378.600	39.18	-2.54	36.64	74.00	-37.36	peak			
2	2390.000	41.86	-2.51	39.35	74.00	-34.65	peak			
3	2400.000	59.16	-2.49	56.67	74.00	-17.33	peak			

Anbotek

Horizontal-AV:

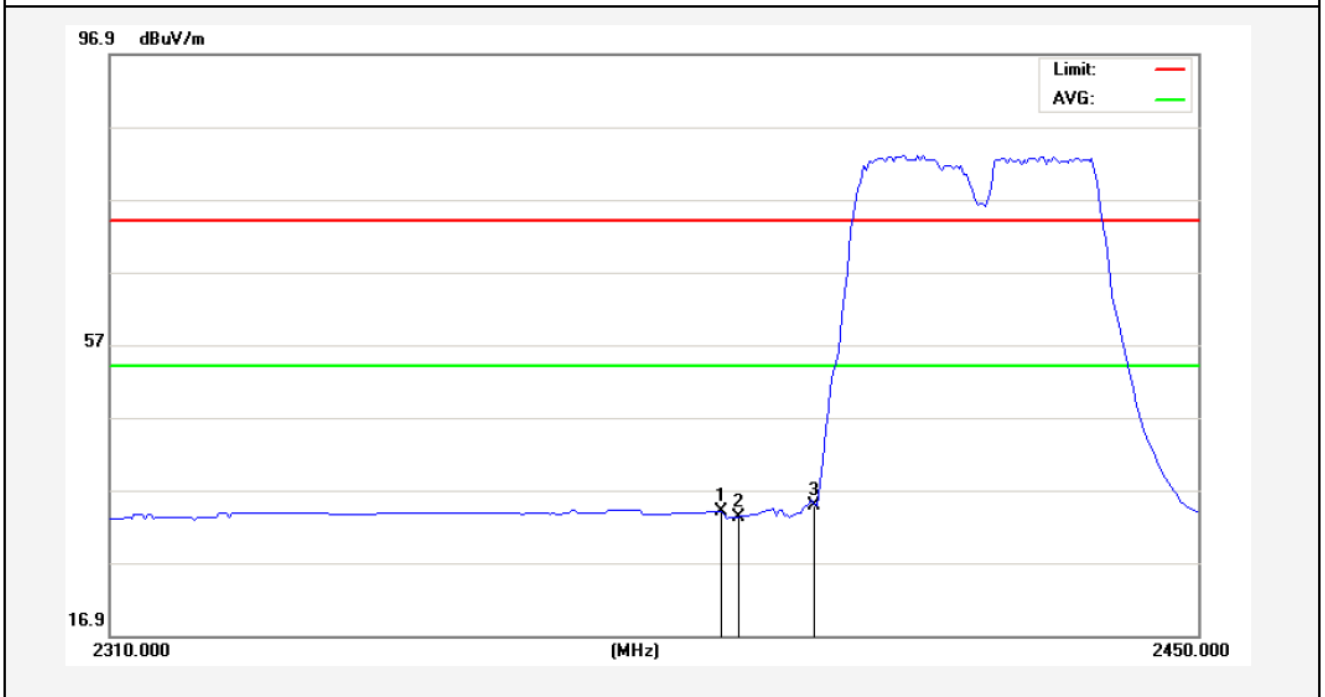

No.	Freq. (MHz)	Reading (dBuV/m)	Factor (dB/m)	Result (dBuV/m)	Limit (dBuV/)	Over Limit (dB)	Detector	Height (cm)	degree (deg)	Remark
1	2387.700	36.54	-2.52	34.02	54.00	-19.98	AVG			
2	2390.000	35.75	-2.51	33.24	54.00	-20.76	AVG			
3	2400.000	37.34	-2.49	34.85	54.00	-19.15	AVG			

Anbotek

Test Mode: 802.11n (HT40)

2422MHz

Vertical-PEAK:

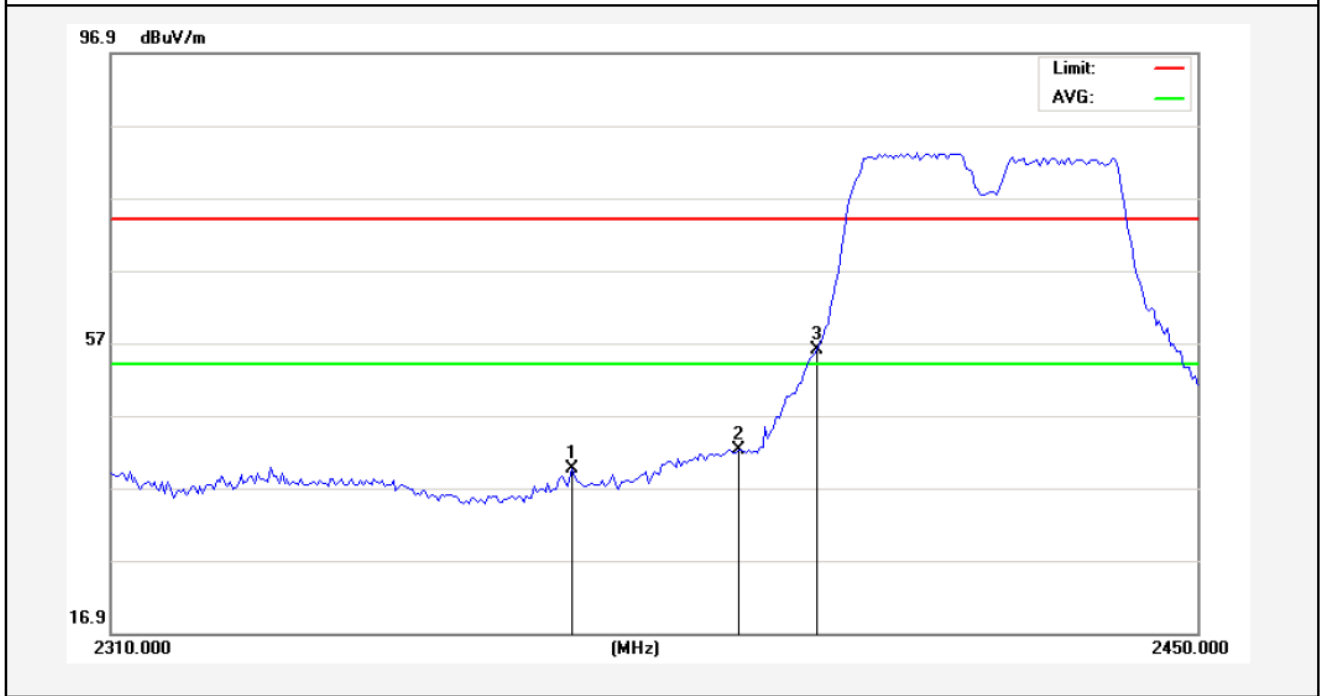

No.	Freq. (MHz)	Reading (dBuV/m)	Factor (dB/m)	Result (dBuV/m)	Limit (dBuV/)	Over Limit (dB)	Detector	Height (cm)	degree (deg)	Remark
1	2368.800	42.23	-2.56	39.67	74.00	-34.33	peak			
2	2390.000	44.77	-2.51	42.26	74.00	-31.74	peak			
3	2400.000	58.43	-2.49	55.94	74.00	-18.06	peak			

Anbotek

Vertical-AV:

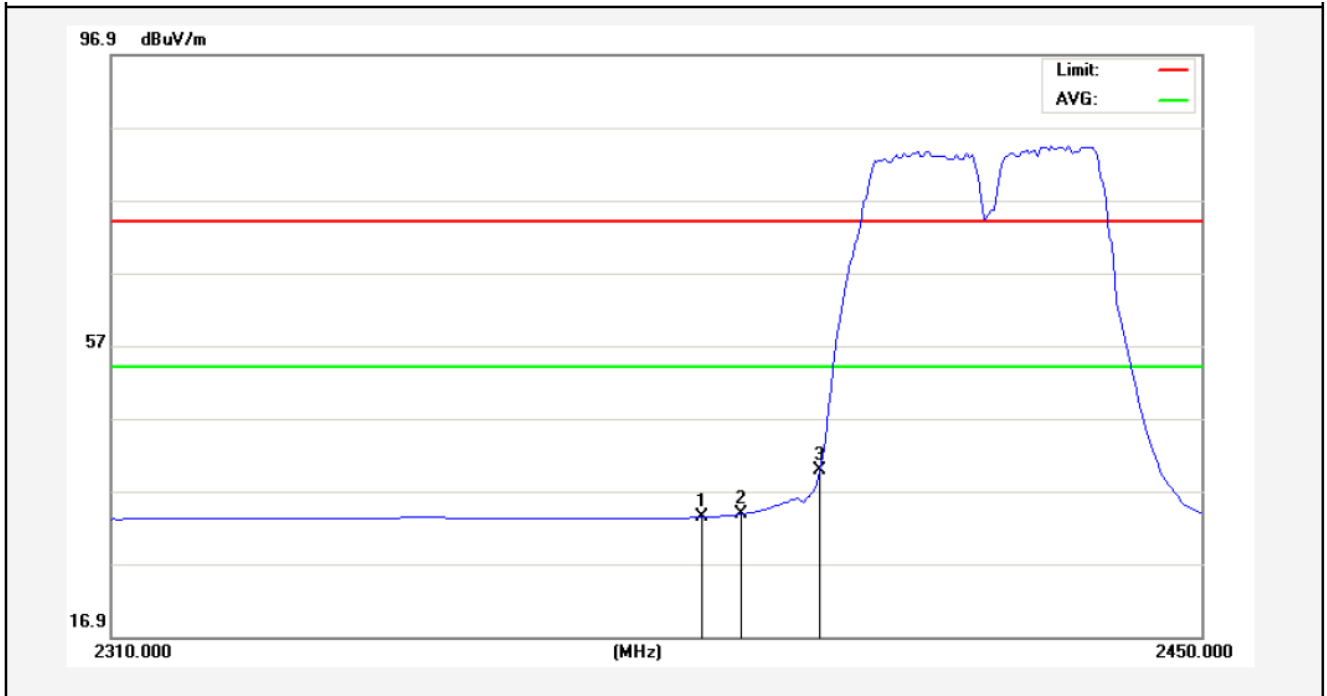

No.	Freq. (MHz)	Reading (dBuV/m)	Factor (dB/m)	Result (dBuV/m)	Limit (dBuV/)	Over Limit (dB)	Detector	Height (cm)	degree (deg)	Remark
1	2385.250	35.92	-2.52	33.40	54.00	-20.60	AVG			
2	2390.000	36.26	-2.51	33.75	54.00	-20.25	AVG			
3	2400.000	42.36	-2.49	39.87	54.00	-14.13	AVG			

Anbotek

Test Mode: 802.11n (HT40)

2452MHz

Horizontal-PEAK:

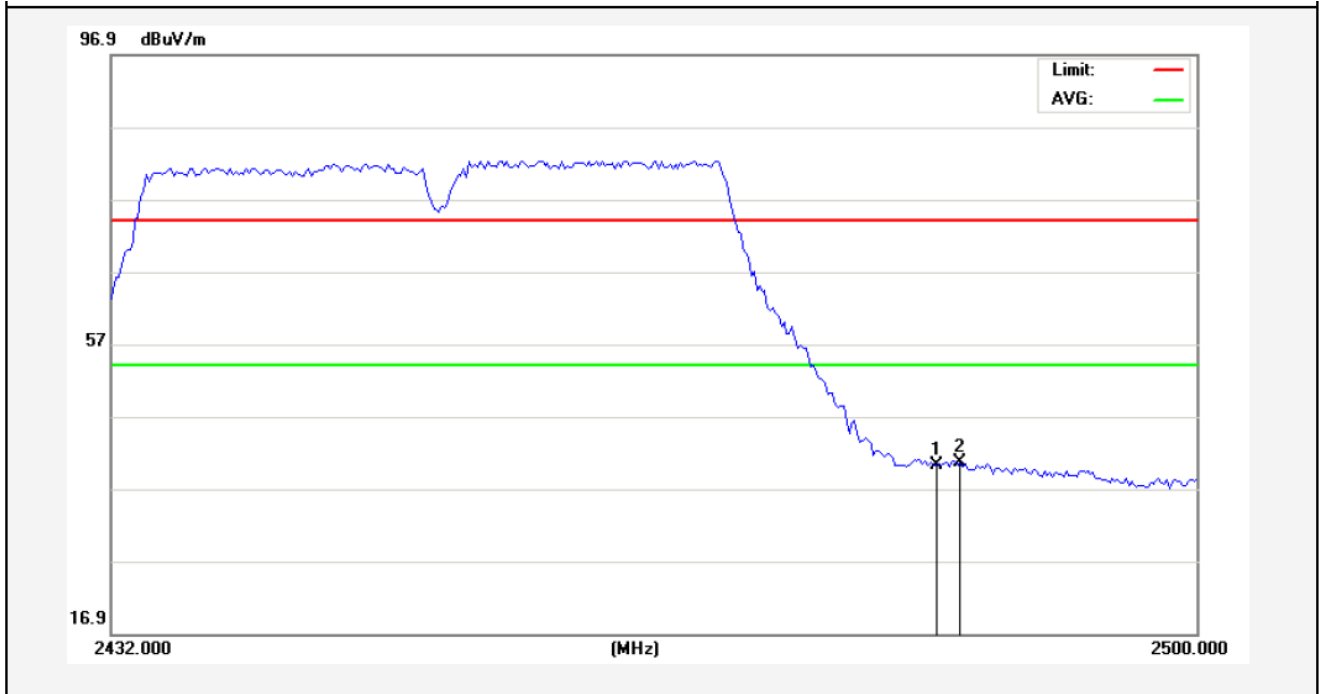

No.	Freq. (MHz)	Reading (dBuV/m)	Factor (dB/m)	Result (dBuV/m)	Limit (dBuV/)	Over Limit (dB)	Detector	Height (cm)	degree (deg)	Remark
1	2483.500	42.58	-2.31	40.27	74.00	-33.73	peak			
2	2485.210	42.93	-2.30	40.63	74.00	-33.37	peak			

Anbotek

Horizontal-AV:

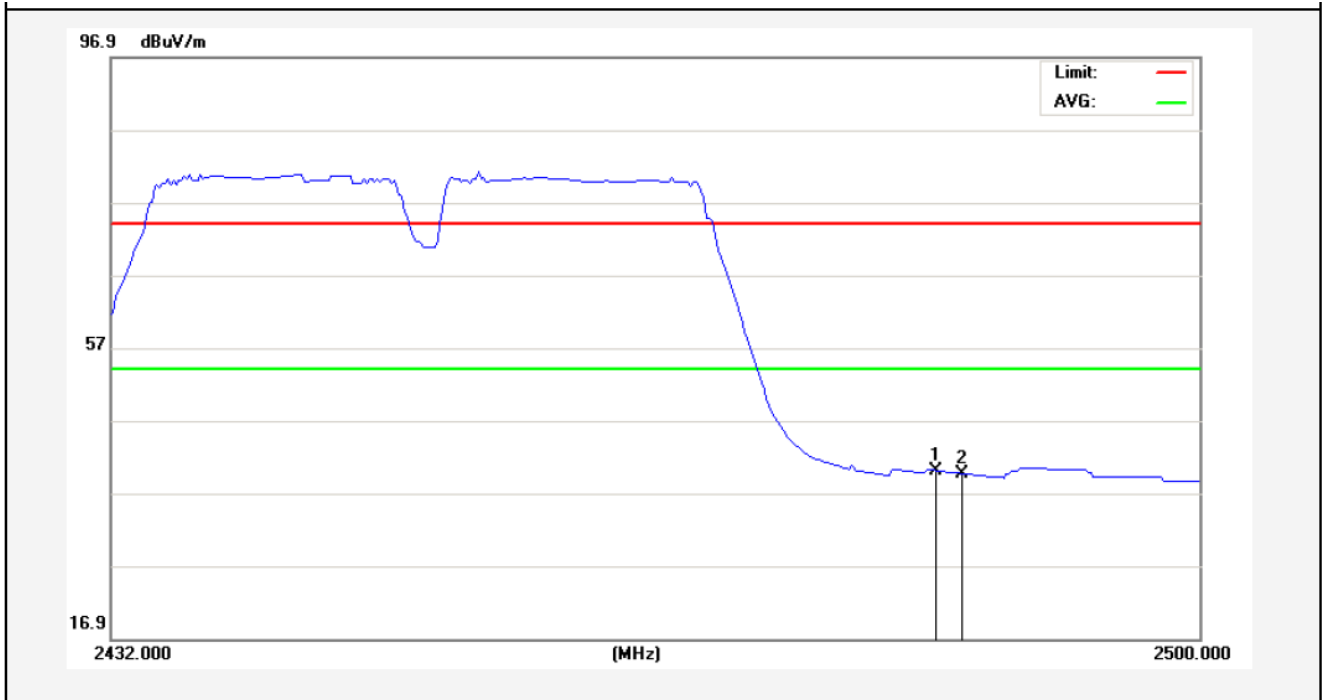

No.	Freq. (MHz)	Reading (dBuV/m)	Factor (dB/m)	Result (dBuV/m)	Limit (dBuV/)	Over Limit (dB)	Detector	Height (cm)	degree (deg)	Remark
1	2483.500	42.35	-2.31	40.04	54.00	-13.96	AVG			
2	2485.380	41.90	-2.30	39.60	54.00	-14.40	AVG			

Anbotek

Test Mode: 802.11n (HT40)
2452MHz
Vertical-PEAK:

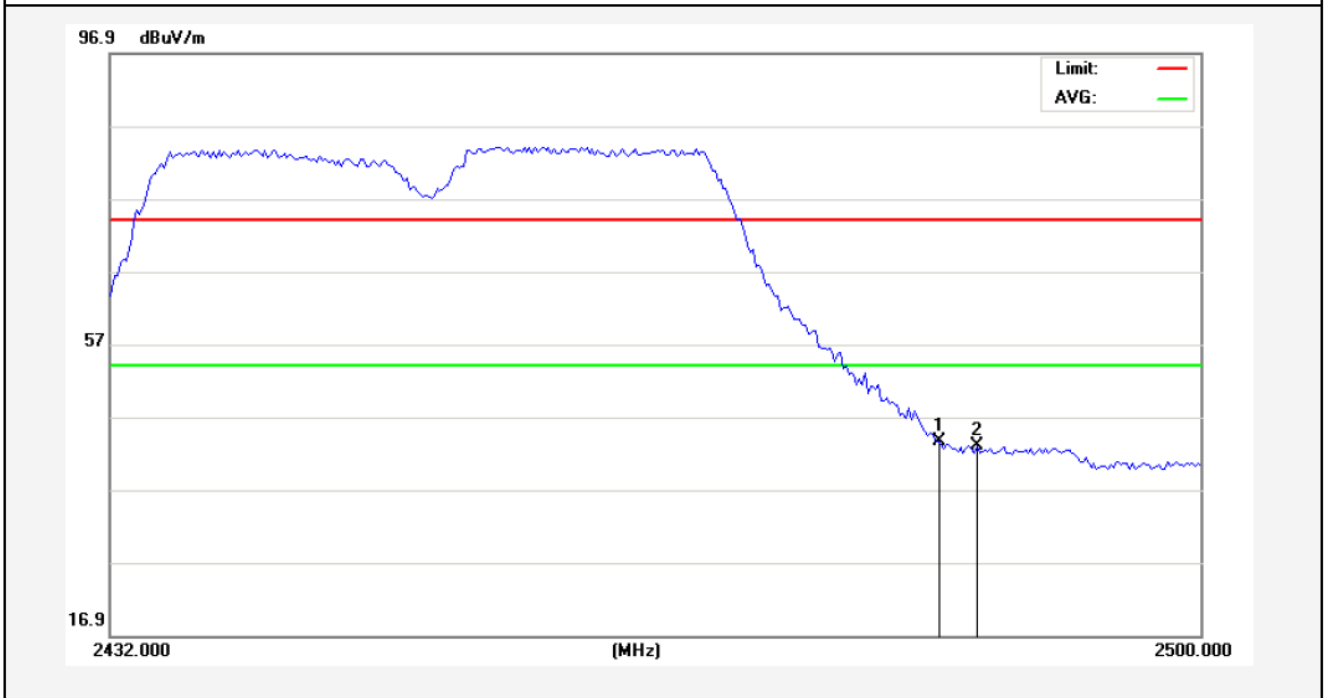

No.	Freq. (MHz)	Reading (dBuV/m)	Factor (dB/m)	Result (dBuV/m)	Limit (dBuV/)	Over Limit (dB)	Detector	Height (cm)	degree (deg)	Remark
1	2483.500	45.94	-2.31	43.63	74.00	-30.37	peak			
2	2486.060	45.21	-2.30	42.91	74.00	-31.09	peak			

Anbotek

Vertical-AV:

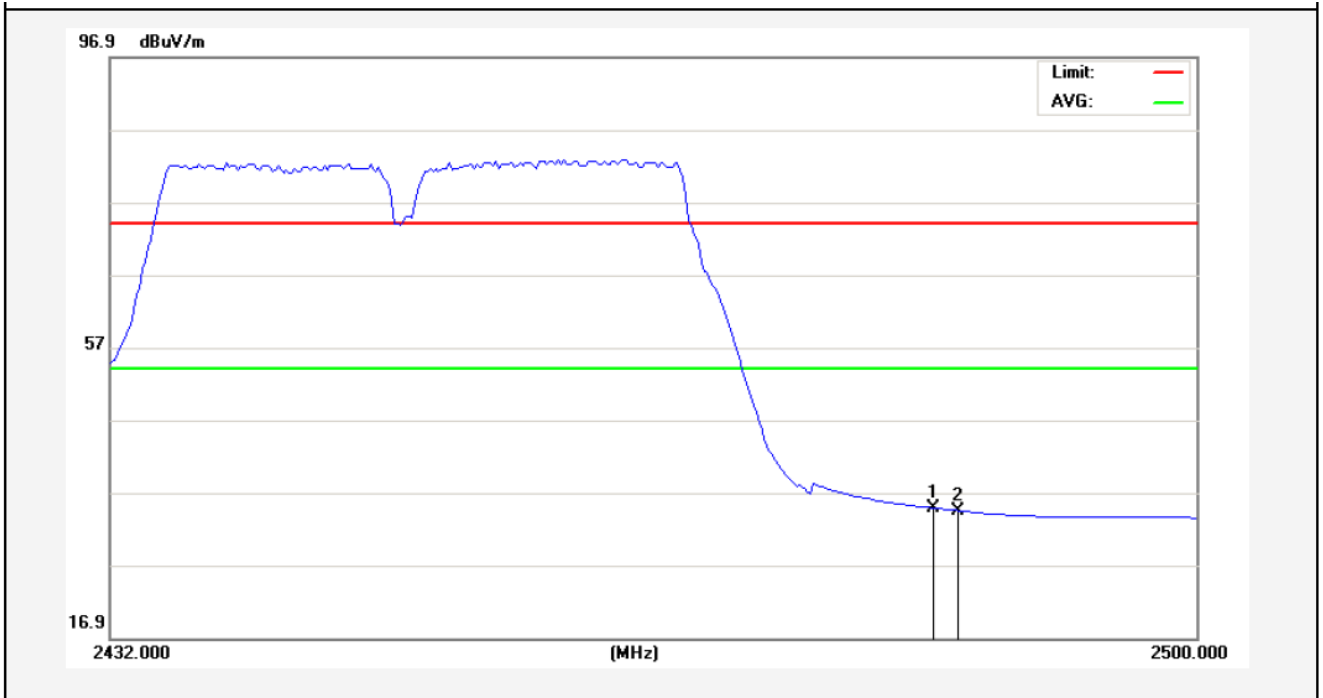

No.	Freq. (MHz)	Reading (dBuV/m)	Factor (dB/m)	Result (dBuV/m)	Limit (dBuV/)	Over Limit (dB)	Detector	Height (cm)	degree (deg)	Remark
1	2483.500	37.14	-2.31	34.83	54.00	-19.17	AVG			
2	2485.040	36.79	-2.30	34.49	54.00	-19.51	AVG			