

Date: 11/05/2016

DUT: Model Name: Solarin; Model Number: SR0020-W; FCC ID: 2AIP8I

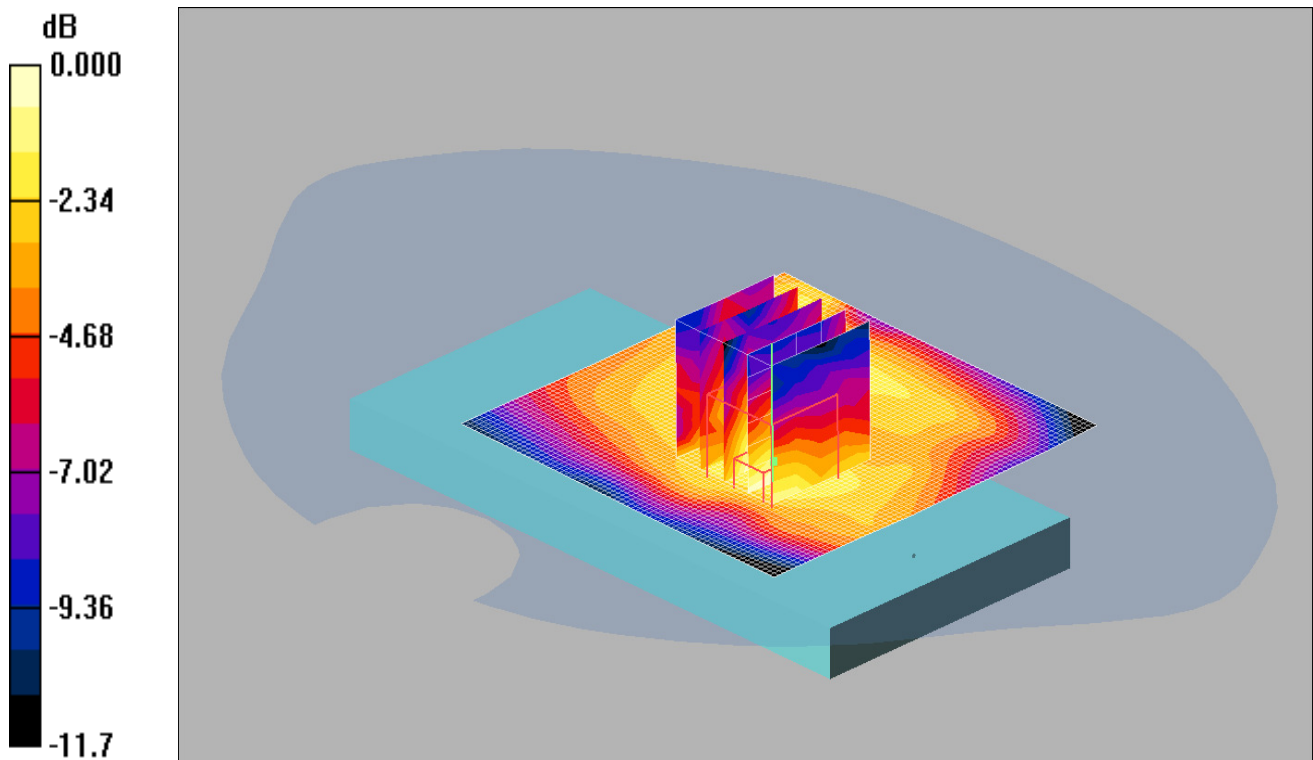

0 dB = 0.035mW/g

Communication System: LTE - Band 12 / 10MHz Channel; Frequency: 711 MHz; Duty Cycle: 1:1  
Medium: 900/750 MHz MSL Medium parameters used (interpolated):  $f = 711$  MHz;  $\sigma = 0.912$  mho/m;  $\epsilon_r = 53.9$ ;  $\rho = 1000$  kg/m<sup>3</sup>  
Phantom section: Flat Section

DASY4 Configuration:

- Probe: ET3DV6 - SN1528; ConvF(6.11, 6.11, 6.11);
- Sensor-Surface: 4mm (Mechanical Surface Detection)
- Electronics: DAE4 Sn450; Calibrated: 28/09/2015
- Phantom: SAM 12a (Site 56); Type: SAM 4.0; Serial: TP:1020
- Measurement SW: DASY4, V4.6 Build 19; Postprocessing SW: SEMCAD, V1.8 Build 159

**Back 1RB low - Hotspot - PBx 2/Area Scan 2 (71x71x1):** Measurement grid: dx=15mm, dy=15mm

Maximum value of SAR (interpolated) = 0.027 mW/g

**Back 1RB low - Hotspot - PBx 2/Zoom Scan (5x5x7) (5x5x7)/Cube 0:** Measurement grid: dx=8mm, dy=8mm, dz=5mm

Reference Value = 4.38 V/m; Power Drift = -0.109 dB

Peak SAR (extrapolated) = 0.053 W/kg

**SAR(1 g) = 0.032 mW/g; SAR(10 g) = 0.018 mW/g**

Maximum value of SAR (measured) = 0.035 mW/g

Date: 18/04/2016

DUT: Model Name: Solarin; Model Number: SR0020-W; FCC ID: 2AIP8I

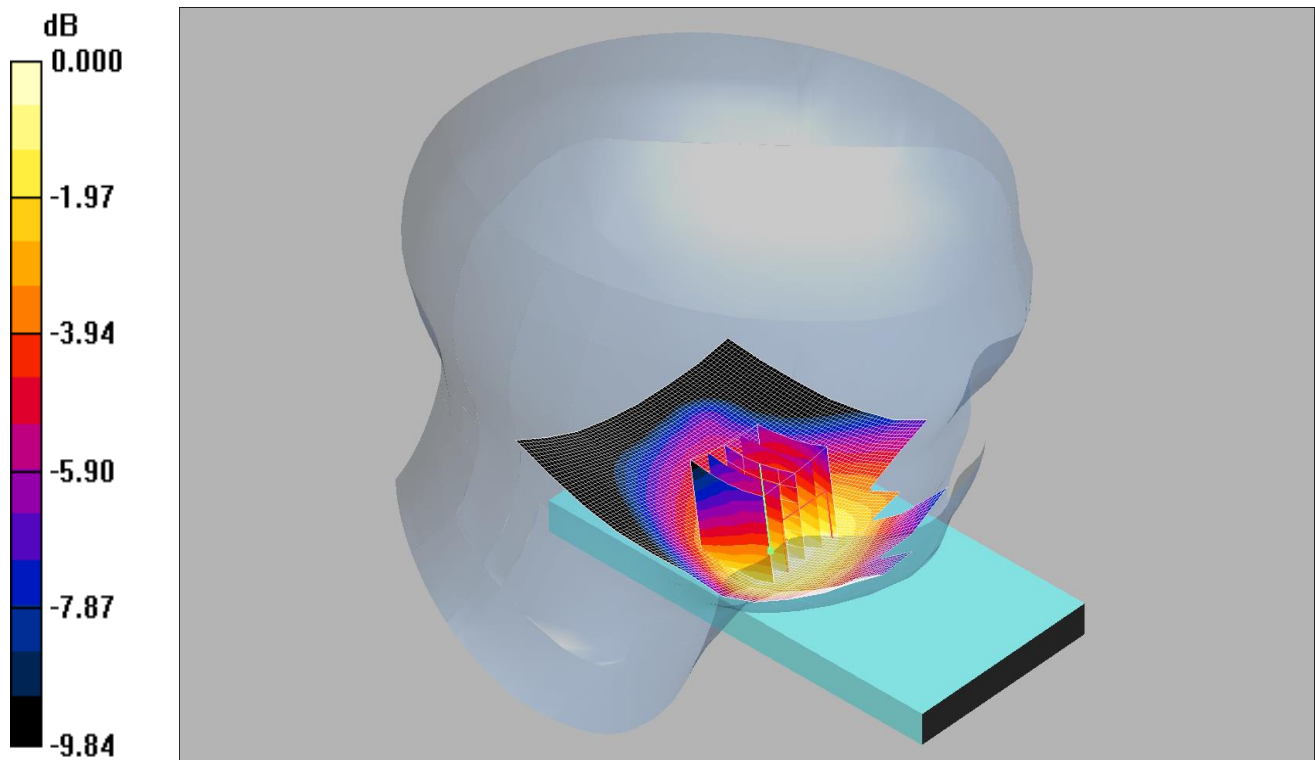

0 dB = 0.066mW/g

Communication System: LTE - Band 13 / 10MHz Channel; Frequency: 782 MHz; Duty Cycle: 1:1  
Medium: 750 MHz HSL Medium parameters used (interpolated):  $f = 782$  MHz;  $\sigma = 0.881$  mho/m;  $\epsilon_r = 39.9$ ;  $\rho = 1000$  kg/m<sup>3</sup>  
Phantom section: Left Section

DASY4 Configuration:

- Probe: ET3DV6 - SN1586; ConvF(6.6, 6.6, 6.6);
- Sensor-Surface: 3mm (Mechanical Surface Detection)
- Electronics: DAE4 Sn450; Calibrated: 28/09/2015
- Phantom: SAM 12b (Site 57); Type: SAM 4.0; Serial: TP:1031
- Measurement SW: DASY4, V4.7 Build 80; Postprocessing SW: SEMCAD, V1.8 Build 186

**Touch Left - Head - PBx/Area Scan (71x121x1):** Measurement grid: dx=15mm, dy=15mm

Maximum value of SAR (interpolated) = 0.066 mW/g

**Touch Left - Head - PBx/Zoom Scan (5x5x7) 3 2 (5x5x7)/Cube 0:** Measurement grid: dx=8mm, dy=8mm, dz=5mm

Reference Value = 3.12 V/m; Power Drift = -0.061 dB

Peak SAR (extrapolated) = 0.082 W/kg

**SAR(1 g) = 0.059 mW/g; SAR(10 g) = 0.045 mW/g**

Maximum value of SAR (measured) = 0.066 mW/g

Date: 13/05/2016

**DUT: Model Name: Solarin; Model Number: SR0020-W; FCC ID: 2AIP8I**

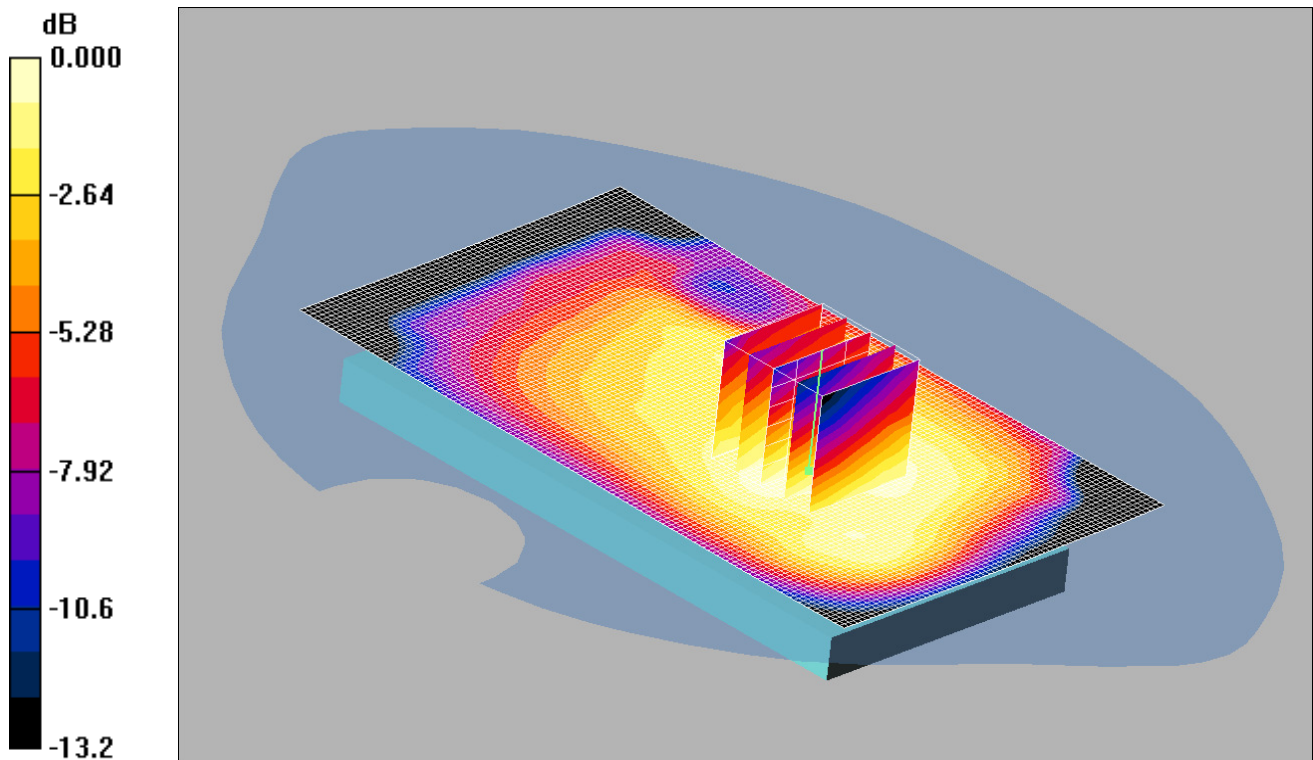

0 dB = 0.268mW/g

Communication System: LTE - Band 13 / 10MHz Channel; Frequency: 782 MHz; Duty Cycle: 1:1  
Medium: 900/750 MHz MSL Medium parameters used (interpolated):  $f = 782$  MHz;  $\sigma = 0.949$  mho/m;  $\epsilon_r = 54.5$ ;  $\rho = 1000$  kg/m<sup>3</sup>  
Phantom section: Flat Section

DASY4 Configuration:

- Probe: ET3DV6 - SN1528; ConvF(6.11, 6.11, 6.11);

- Sensor-Surface: 4mm (Mechanical Surface Detection)

- Electronics: DAE4 Sn450; Calibrated: 28/09/2015

- Phantom: SAM 12a (Site 56); Type: SAM 4.0; Serial: TP:1020

- Measurement SW: DASY4, V4.6 Build 19; Postprocessing SW: SEMCAD, V1.8 Build 159

**Back 1RB High - Hotspot - PBx 3/Area Scan (71x121x1):** Measurement grid: dx=15mm, dy=15mm

Maximum value of SAR (interpolated) = 0.270 mW/g

**Back 1RB High - Hotspot - PBx 3/Zoom Scan (5x5x7) (5x5x7)/Cube 0:** Measurement grid: dx=8mm, dy=8mm, dz=5mm

Reference Value = 17.3 V/m; Power Drift = -0.078 dB

Peak SAR (extrapolated) = 0.334 W/kg

**SAR(1 g) = 0.251 mW/g; SAR(10 g) = 0.183 mW/g**

Maximum value of SAR (measured) = 0.268 mW/g

Date: 19/04/2016

DUT: Model Name: Solarin; Model Number: SR0020-W; FCC ID: 2AIP8I

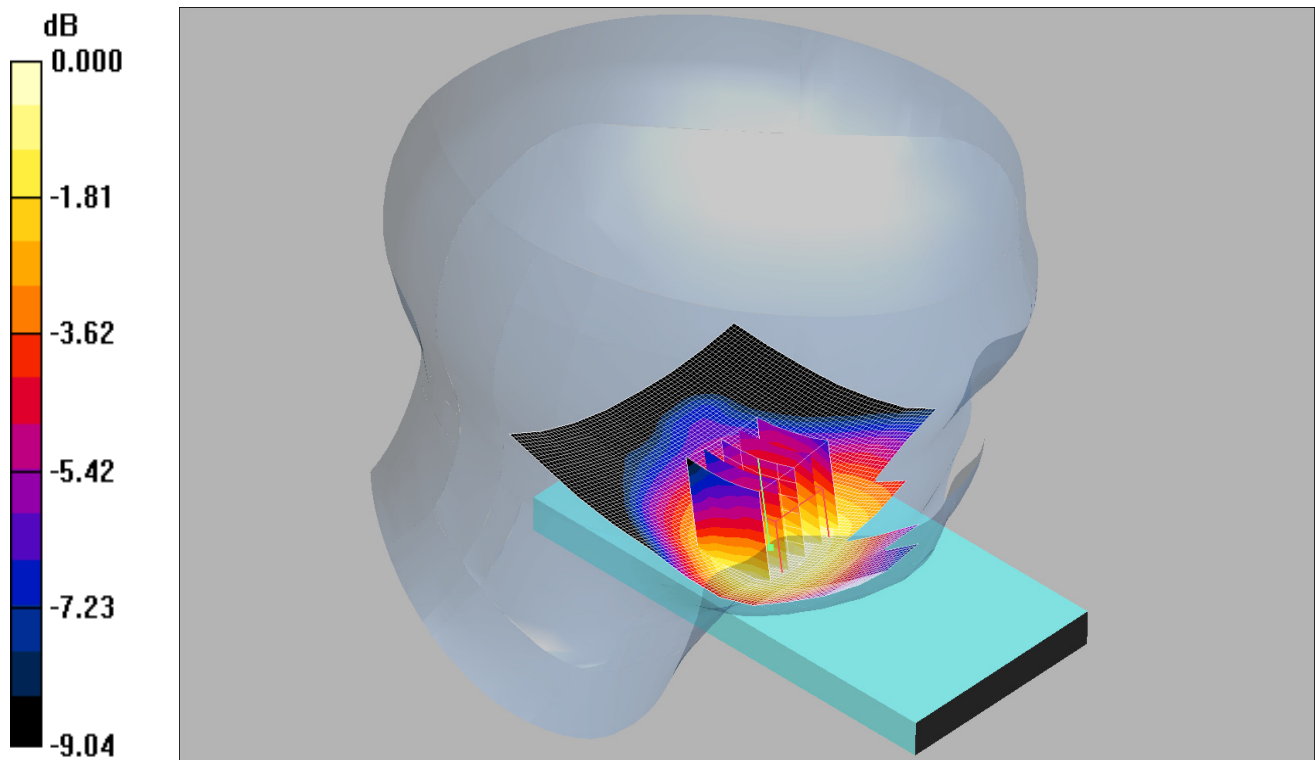

0 dB = 0.042mW/g

Communication System: LTE - Band 17 / 10MHz Channel; Frequency: 710 MHz; Duty Cycle: 1:1  
Medium: 750 MHz HSL Medium parameters used (interpolated):  $f = 710$  MHz;  $\sigma = 0.838$  mho/m;  $\epsilon_r = 40.4$ ;  $\rho = 1000$  kg/m<sup>3</sup>  
Phantom section: Left Section

DASY4 Configuration:

- Probe: ET3DV6 - SN1586; ConvF(6.6, 6.6, 6.6);
- Sensor-Surface: 3mm (Mechanical Surface Detection)
- Electronics: DAE4 Sn450; Calibrated: 28/09/2015
- Phantom: SAM 12b (Site 57); Type: SAM 4.0; Serial: TP:1031
- Measurement SW: DASY4, V4.7 Build 80; Postprocessing SW: SEMCAD, V1.8 Build 186

**Touch Left - Head - PBx/Area Scan (71x121x1):** Measurement grid: dx=15mm, dy=15mm

Maximum value of SAR (interpolated) = 0.042 mW/g

**Touch Left - Head - PBx/Zoom Scan (5x5x7) (5x5x7)/Cube 0:** Measurement grid: dx=8mm, dy=8mm, dz=5mm

Reference Value = 2.36 V/m; Power Drift = -0.006 dB

Peak SAR (extrapolated) = 0.051 W/kg

**SAR(1 g) = 0.038 mW/g; SAR(10 g) = 0.029 mW/g**

Maximum value of SAR (measured) = 0.042 mW/g

Date: 17/05/2016

DUT: Model Name: Solarin; Model Number: SR0020-W; FCC ID: 2AIP8I

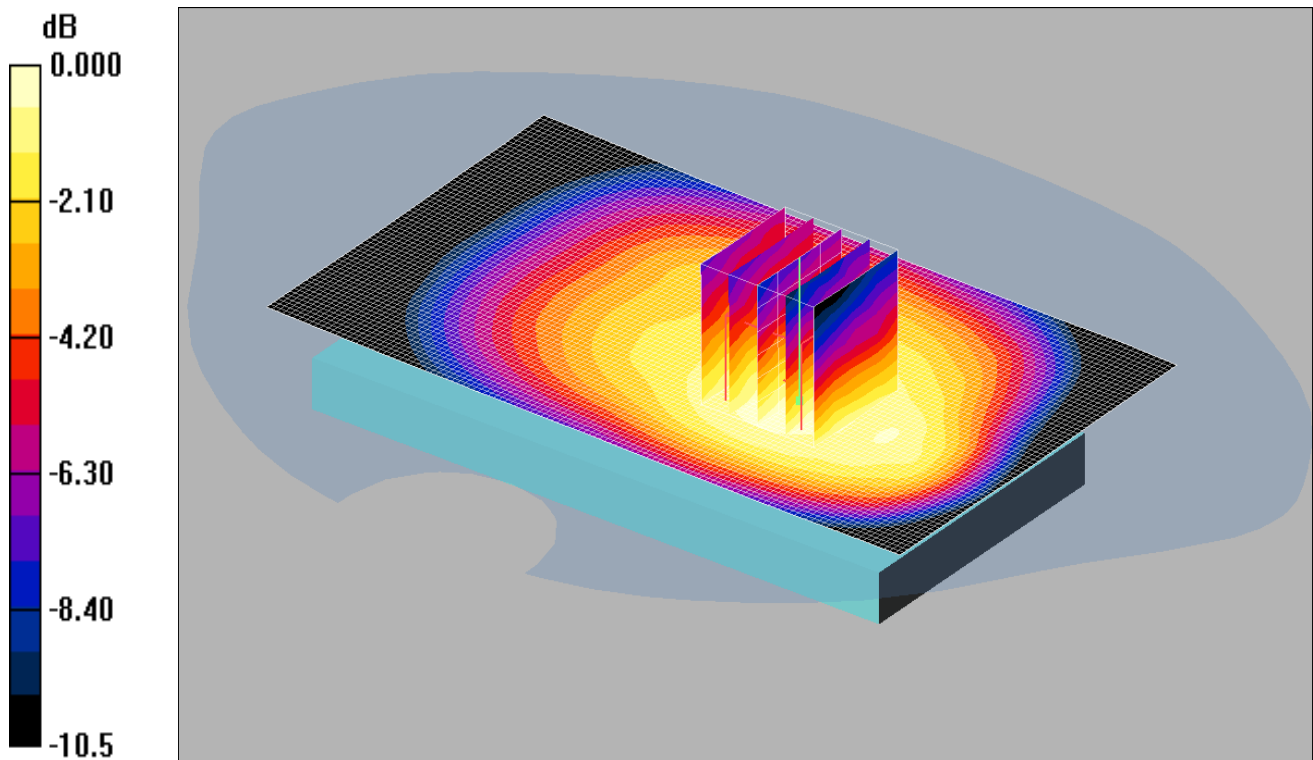

0 dB = 0.159mW/g

Communication System: LTE - Band 17 / 10MHz Channel; Frequency: 709 MHz; Duty Cycle: 1:1  
Medium: 900/750 MHz MSL Medium parameters used (interpolated):  $f = 709$  MHz;  $\sigma = 0.904$  mho/m;  $\epsilon_r = 54.2$ ;  $\rho = 1000$  kg/m<sup>3</sup>  
Phantom section: Flat Section

DASY4 Configuration:

- Probe: ET3DV6 - SN1528; ConvF(6.11, 6.11, 6.11);

- Sensor-Surface: 4mm (Mechanical Surface Detection)

- Electronics: DAE4 Sn450; Calibrated: 28/09/2015

- Phantom: SAM 12a (Site 56); Type: SAM 4.0; Serial: TP:1020

- Measurement SW: DASY4, V4.6 Build 19; Postprocessing SW: SEMCAD, V1.8 Build 159

**Back 1RB High - Hotspot - PBx 3/Area Scan (71x121x1):** Measurement grid: dx=15mm, dy=15mm

Maximum value of SAR (interpolated) = 0.154 mW/g

**Back 1RB High - Hotspot - PBx 3/Zoom Scan (5x5x7) (5x5x7)/Cube 0:** Measurement grid: dx=8mm, dy=8mm, dz=5mm

Reference Value = 13.5 V/m; Power Drift = 0.057 dB

Peak SAR (extrapolated) = 0.193 W/kg

**SAR(1 g) = 0.149 mW/g; SAR(10 g) = 0.110 mW/g**

Maximum value of SAR (measured) = 0.159 mW/g

Date: 19/4/2016

DUT: Model Name: Solarin; Model Number: SR0020-W; FCC ID: 2AIP8I

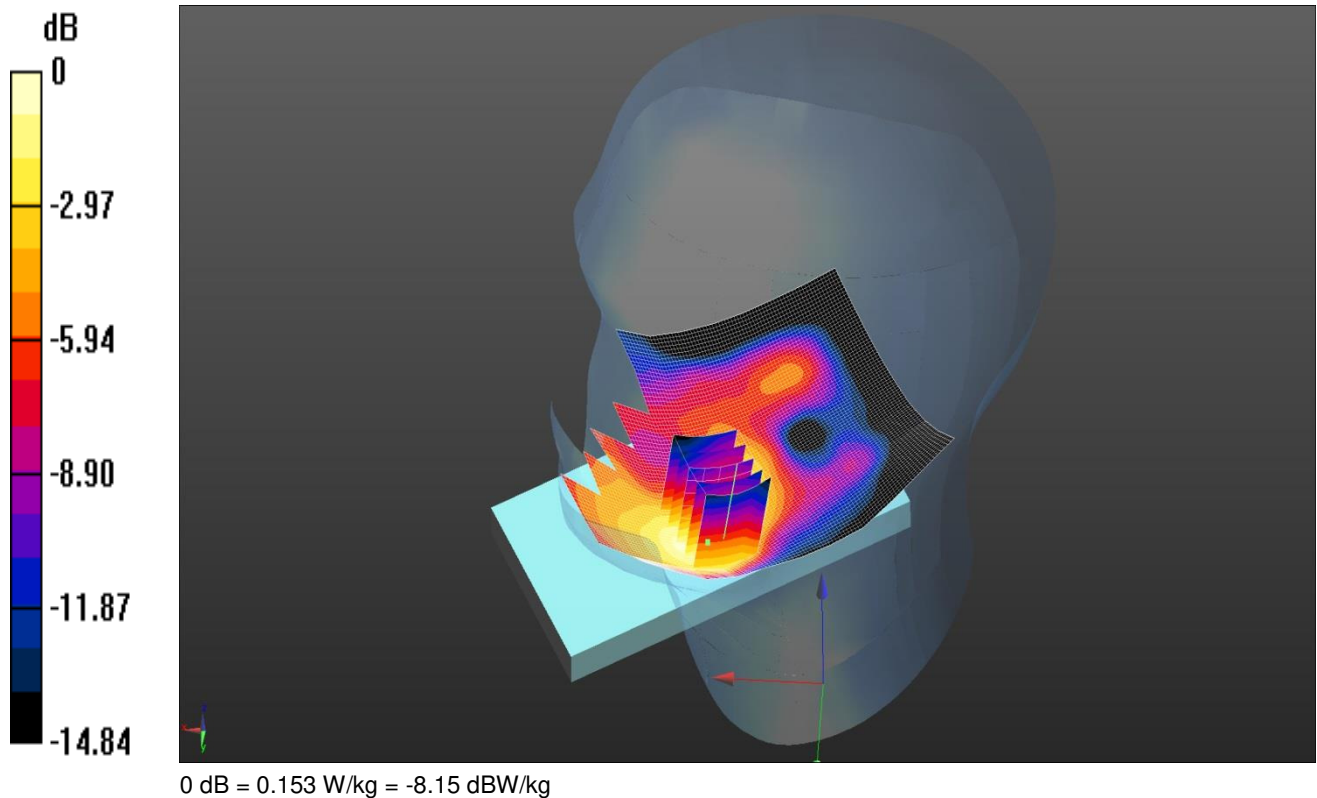

Communication System: UID 0, LTE FDD Bands - 20MHz Channel BW (0); Frequency: 1860 MHz; Duty Cycle: 1:1  
Medium: 1900 HSL Medium parameters used (interpolated):  $f = 1860$  MHz;  $\sigma = 1.392$  S/m;  $\epsilon_r = 39.173$ ;  $\rho = 1000$  kg/m<sup>3</sup>  
Phantom section: Right Section

DASY4 Configuration:

- Probe: ES3DV3 - SN3341; ConvF(5.07, 5.07, 5.07); Calibrated: 25/8/2015;
- Sensor-Surface: 4mm (Mechanical Surface Detection)
- Electronics: DAE4 Sn1435; Calibrated: 12/2/2016
- Phantom: SAM A (30deg probe tilt) with CRP v5.0; Type: QD000P40CD; Serial: TP:1836
- ; SEMCAD X Version 14.6.10 (7331)

**Configuration/Touch Right 1RB Low - Head - PB0/Area Scan (81x121x1):** Interpolated grid: dx=1.500 mm, dy=1.500 mm  
Maximum value of SAR (interpolated) = 0.162 W/kg

**Configuration/Touch Right 1RB Low - Head - PB0/Zoom Scan (7x7x7) 2 2 2 (5x5x7)/Cube 0:** Measurement grid:  
dx=8mm, dy=8mm, dz=5mm

Reference Value = 11.00 V/m; Power Drift = -0.07 dB

Peak SAR (extrapolated) = 0.214 W/kg

**SAR(1 g) = 0.144 W/kg; SAR(10 g) = 0.091 W/kg**

Maximum value of SAR (measured) = 0.153 W/kg



Date: 9/5/2016

DUT: Model Name: Solarin; Model Number: SR0020-W; FCC ID: 2AIP8I

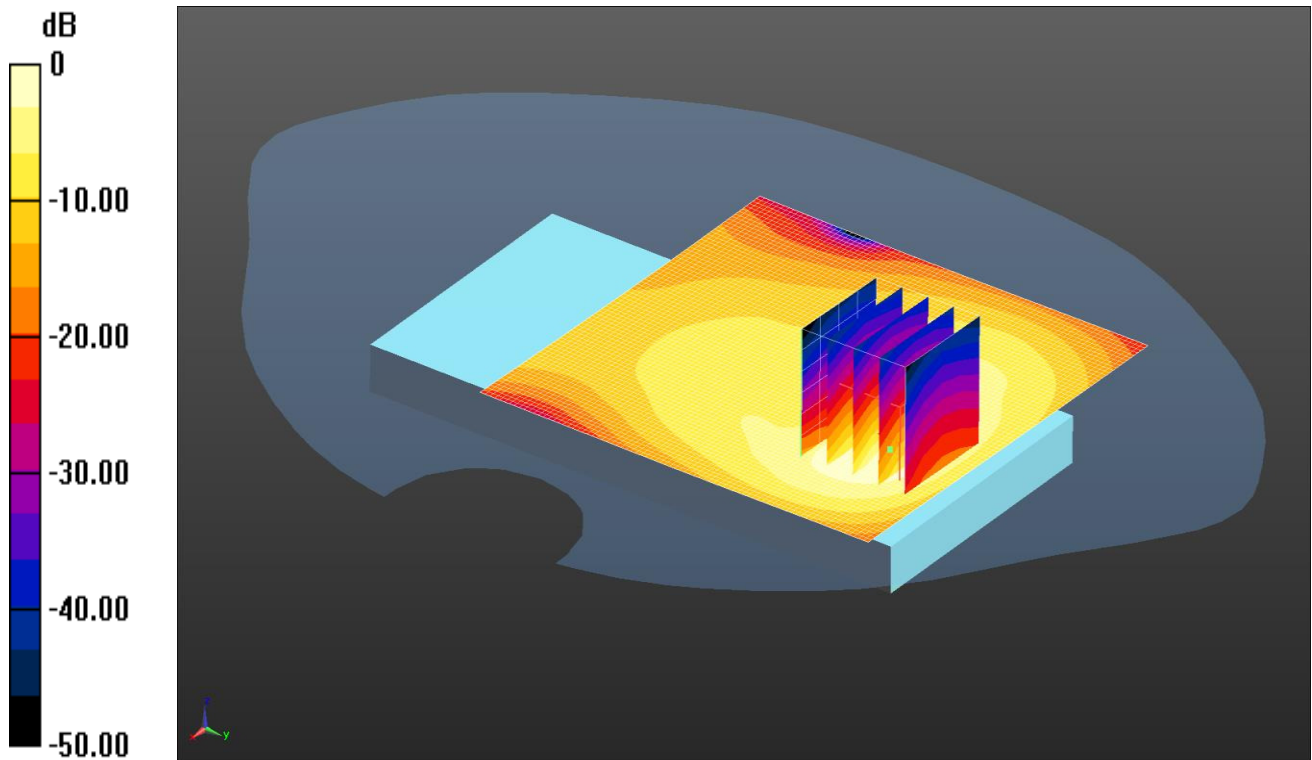

0 dB = 0.413 W/kg = -3.84 dBW/kg

Communication System: UID 0, LTE FDD Bands - 20MHz Channel BW (0); Frequency: 1905 MHz; Duty Cycle: 1:1  
Medium: 1900 MHz MSL Medium parameters used (interpolated):  $f = 1905$  MHz;  $\sigma = 1.507$  S/m;  $\epsilon_r = 51.761$ ;  $\rho = 1000$  kg/m<sup>3</sup>  
Phantom section: Flat Section  
DASY4 Configuration:  
- Probe: ES3DV3 - SN3341; ConvF(4.78, 4.78, 4.78); Calibrated: 25/8/2015;  
- Sensor-Surface: 4mm (Mechanical Surface Detection)  
- Electronics: DAE4 Sn1435; Calibrated: 12/2/2016  
- Phantom: SAM A (30deg probe tilt) with CRP v5.0; Type: QD000P40CD; Serial: TP:1836  
- ; SEMCAD X Version 14.6.10 (7331)

**Configuration/Back 1RB Low - Hotspot - PB1 2/Area Scan (81x81x1):** Interpolated grid: dx=1.500 mm, dy=1.500 mm

Maximum value of SAR (interpolated) = 0.413 W/kg

**Configuration/Back 1RB Low - Hotspot - PB1 2/Zoom Scan (5x5x7) 2 (5x5x7)/Cube 0:** Measurement grid: dx=8mm, dy=8mm, dz=5mm

Reference Value = 7.209 V/m; Power Drift = 0.03 dB

Peak SAR (extrapolated) = 0.824 W/kg

**SAR(1 g) = 0.442 W/kg; SAR(10 g) = 0.222 W/kg**

Maximum value of SAR (measured) = 0.513 W/kg

Date: 16/05/2016

DUT: Model Name: Solarin; Model Number: SR0020-W; FCC ID: 2AIP8I

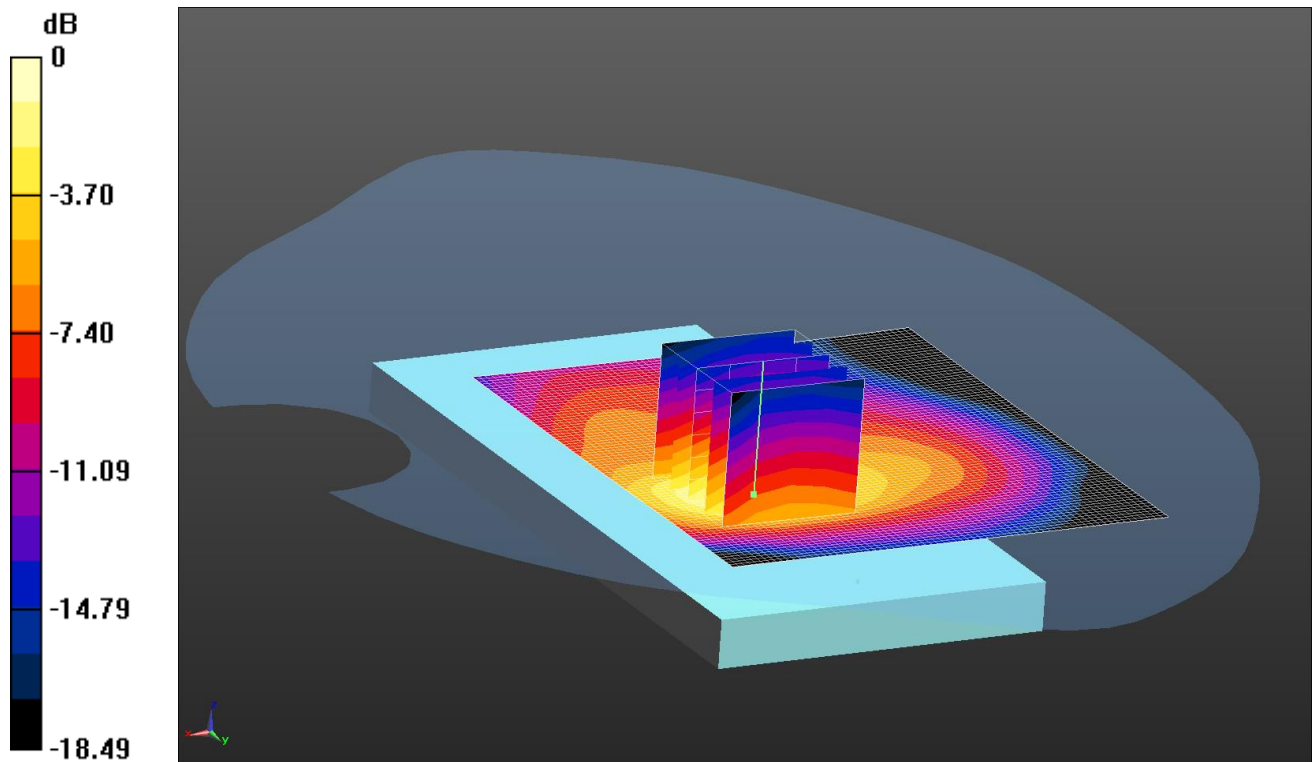

0 dB = 0.332 W/kg = -4.79 dBW/kg

Communication System: UID 0, LTE FDD Bands - 20MHz Channel BW (0); Frequency: 1860 MHz; Duty Cycle: 1:1  
Medium: 1900 MHz MSL Medium parameters used (interpolated):  $f = 1860$  MHz;  $\sigma = 1.495$  S/m;  $\epsilon_r = 51.771$ ;  $\rho = 1000$  kg/m<sup>3</sup>  
Phantom section: Flat Section

DASY4 Configuration:

- Probe: EX3DV4 - SN3995; ConvF(7.84, 7.84, 7.84); Calibrated: 26/04/2016;
- Sensor-Surface: 4mm (Mechanical Surface Detection)
- Electronics: DAE4 Sn1435; Calibrated: 12/02/2016
- Phantom: SAM 1-2 (30deg probe tilt) with CRP v5.0; Type: QD000P40CD; Serial: TP:1817
- ; SEMCAD X Version 14.6.10 (7372)

**Configuration/Back 1RB Low - Bodyworn - PB0/Area Scan (71x81x1):** Interpolated grid: dx=1.500 mm, dy=1.500 mm  
Maximum value of SAR (interpolated) = 0.308 W/kg

**Configuration/Back 1RB Low - Bodyworn - PB0/Zoom Scan (5x5x7) 2 (5x5x7)/Cube 0:** Measurement grid: dx=8mm, dy=8mm, dz=5mm

Reference Value = 7.948 V/m; Power Drift = -0.13 dB

Peak SAR (extrapolated) = 0.502 W/kg

**SAR(1 g) = 0.294 W/kg; SAR(10 g) = 0.161 W/kg**

Maximum value of SAR (measured) = 0.332 W/kg



Date: 06/05/2016

DUT: Model Name: Solarin; Model Number: SR0020-W; FCC ID: 2AIP8I

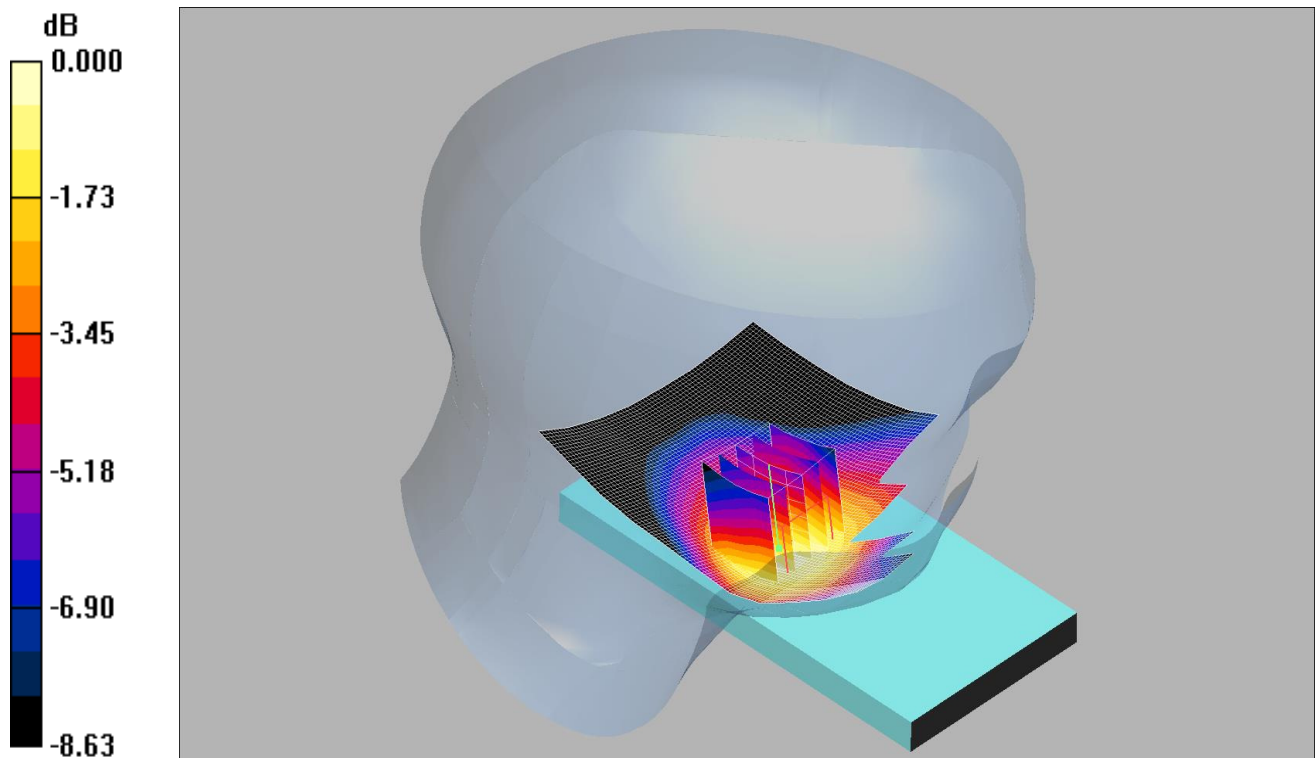

0 dB = 0.125mW/g

Communication System: LTE Band 26 / 15MHz; Frequency: 831.5 MHz; Duty Cycle: 1:1  
Medium: 900 MHz HSL Medium parameters used (interpolated):  $f = 831.5$  MHz;  $\sigma = 0.909$  mho/m;  $\epsilon_r = 40.3$ ;  $\rho = 1000$  kg/m<sup>3</sup>  
Phantom section: Left Section

DASY4 Configuration:

- Probe: ET3DV6 - SN1586; ConvF(6.31, 6.31, 6.31);
- Sensor-Surface: 4mm (Mechanical Surface Detection)
- Electronics: DAE4 Sn450; Calibrated: 28/09/2015
- Phantom: SAM 12b (Site 57); Type: SAM 4.0; Serial: TP:1031
- Measurement SW: DASY4, V4.7 Build 80; Postprocessing SW: SEMCAD, V1.8 Build 186

**Touch Left 1RB Low - Head - PBx/Area Scan (71x111x1):** Measurement grid: dx=15mm, dy=15mm

Maximum value of SAR (interpolated) = 0.121 mW/g

**Touch Left 1RB Low - Head - PBx/Zoom Scan (5x5x7) (5x5x7)/Cube 0:** Measurement grid: dx=8mm, dy=8mm, dz=5mm

Reference Value = 11.9 V/m; Power Drift = -0.063 dB

Peak SAR (extrapolated) = 0.140 W/kg

**SAR(1 g) = 0.118 mW/g; SAR(10 g) = 0.090 mW/g**

Maximum value of SAR (measured) = 0.125 mW/g

Date: 28/04/2016

DUT: Model Name: Solarin; Model Number: SR0020-W; FCC ID: 2AIP8I

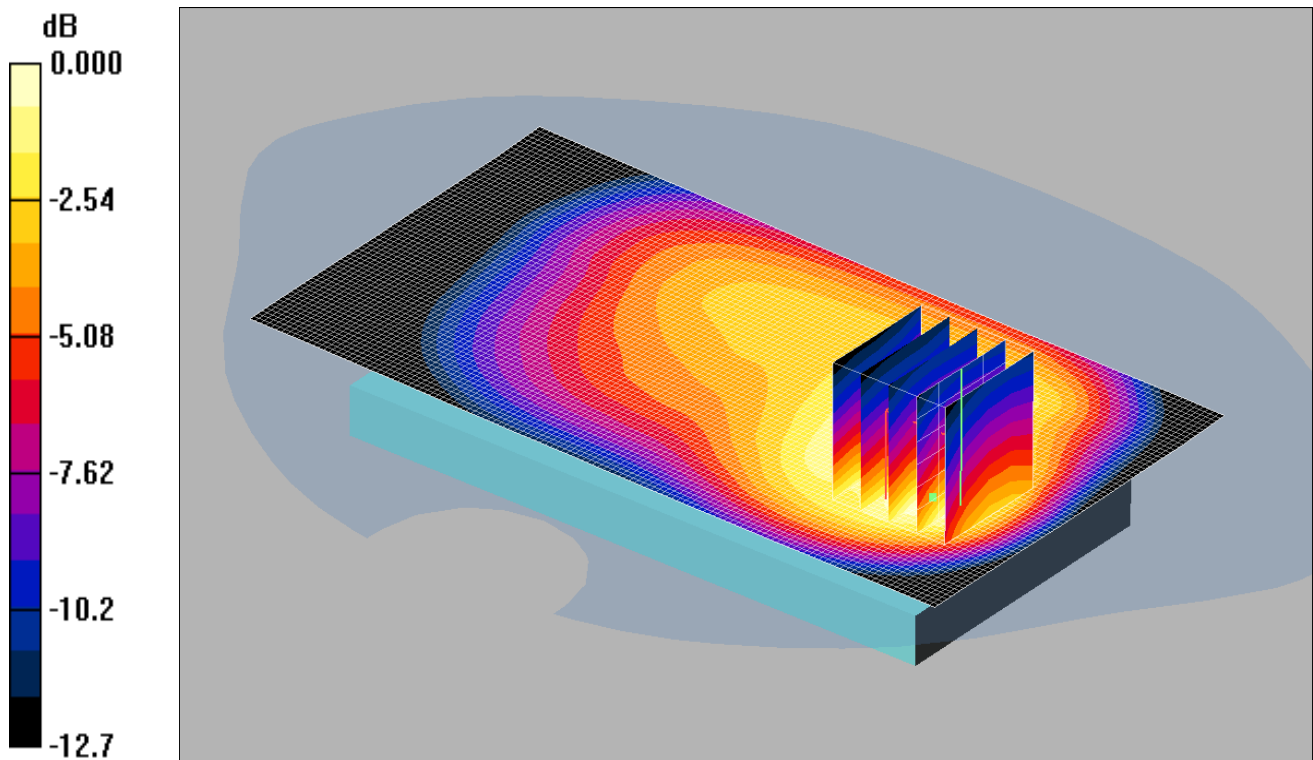

0 dB = 0.524mW/g

Communication System: LTE - Band 26 / 15MHz Channel; Frequency: 841.5 MHz; Duty Cycle: 1:1  
Medium: 900 MHz MSL Medium parameters used (interpolated):  $f = 841.5$  MHz;  $\sigma = 0.98$  mho/m;  $\epsilon_r = 52.9$ ;  $\rho = 1000$  kg/m<sup>3</sup>  
Phantom section: Flat Section

DASY4 Configuration:

- Probe: ET3DV6 - SN1529; ConvF(5.98, 5.98, 5.98);
- Sensor-Surface: 3mm (Mechanical Surface Detection)
- Electronics: DAE3 Sn394; Calibrated: 26/05/2015
- Phantom: SAM 12a (Site 56); Type: SAM 4.0; Serial: TP:1020
- Measurement SW: DASY4, V4.6 Build 19; Postprocessing SW: SEMCAD, V1.8 Build 159

**Back 1RB Low - Hotspot - PBx 2/Area Scan (71x131x1):** Measurement grid: dx=15mm, dy=15mm

Maximum value of SAR (interpolated) = 0.545 mW/g

**Back 1RB Low - Hotspot - PBx 2/Zoom Scan (5x5x7) (5x5x7)/Cube 0:** Measurement grid: dx=8mm, dy=8mm, dz=5mm

Reference Value = 16.6 V/m; Power Drift = -0.063 dB

Peak SAR (extrapolated) = 1.05 W/kg

**SAR(1 g) = 0.458 mW/g; SAR(10 g) = 0.261 mW/g**

Maximum value of SAR (measured) = 0.524 mW/g

Date: 6/5/2016

DUT: Model Name: Solarin; Model Number: SR0020-W; FCC ID: 2AIP8I

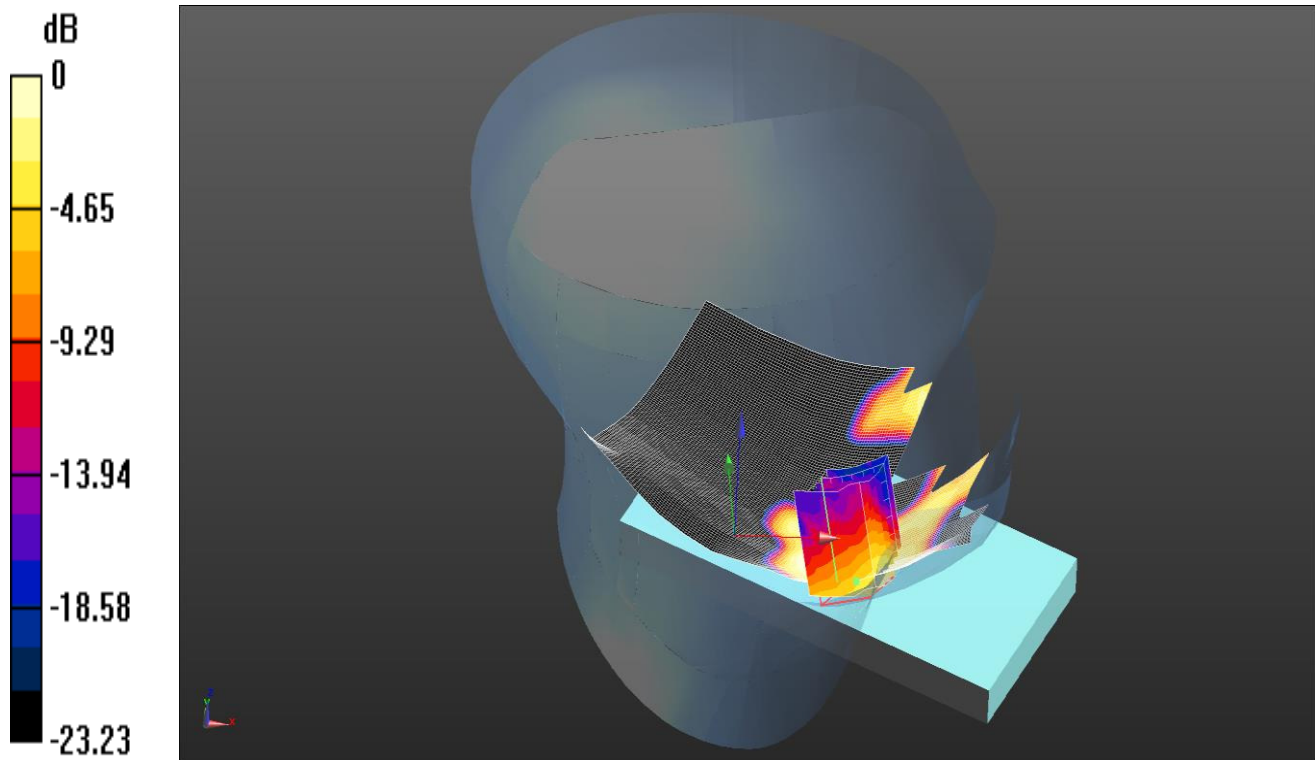

0 dB = 0.0331 W/kg = -14.80 dBW/kg

Communication System: UID 0, LTE Bands - 10MHz Channel BW (0); Frequency: 2310 MHz; Duty Cycle: 1:1  
Medium: 2300 MHz HSL Medium parameters used (interpolated):  $f = 2310$  MHz;  $\sigma = 1.696$  S/m;  $\epsilon_r = 38.143$ ;  $\rho = 1000$  kg/m<sup>3</sup>  
Phantom section: Left Section  
DASY4 Configuration:  
- Probe: ES3DV3 - SN3335; ConvF(4.78, 4.78, 4.78); Calibrated: 23/7/2015;  
- Sensor-Surface: 4mm (Mechanical Surface Detection), Sensor-Surface: 2mm (Mechanical Surface Detection)  
- Electronics: DAE4 Sn432; Calibrated: 25/8/2015  
- Phantom: SAMB (30deg probe tilt) with CRP v5.0; Type: QD000P40CD; Serial: TP:xxxx  
- ; SEMCAD X Version 14.6.10 (7331)

**Configuration/Touch Left 50%RB Low - Head - PB0/Area Scan (101x151x1):** Interpolated grid: dx=1.200 mm, dy=1.200 mm

Maximum value of SAR (interpolated) = 0.0323 W/kg

**Configuration/Touch Left 50%RB Low - Head - PB0/Zoom Scan (7x7x7) (7x7x7)/Cube 0:** Measurement grid: dx=5mm, dy=5mm, dz=5mm

Reference Value = 2.009 V/m; Power Drift = 1.52 dB

Peak SAR (extrapolated) = 0.0500 W/kg

**SAR(1 g) = 0.023 W/kg; SAR(10 g) = 0.013 W/kg**

Maximum value of SAR (measured) = 0.0331 W/kg

Date: 25/05/2016

DUT: Model Name: Solarin; Model Number: SR0020-W; FCC ID: 2AIP8I

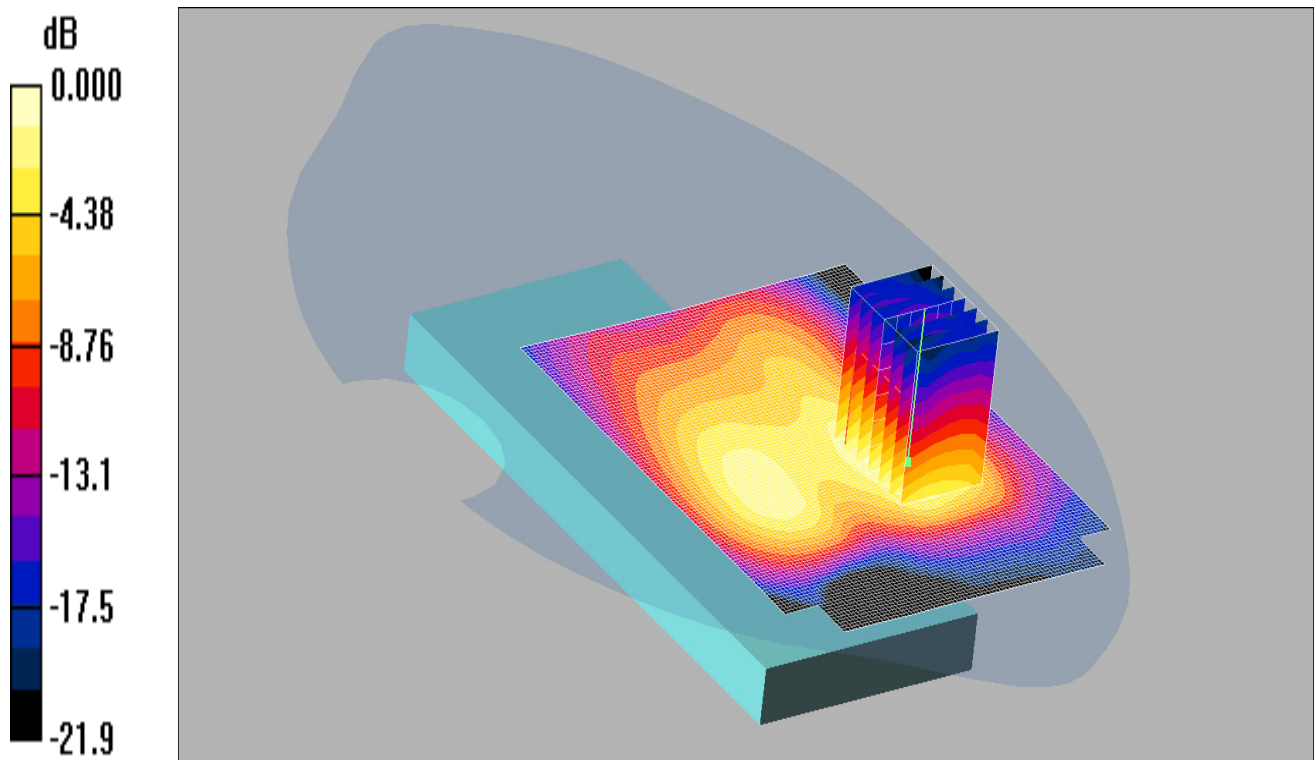

Communication System: LTE - Band 30/ 10MHz Channel; Frequency: 2310 MHz; Duty Cycle: 1:1.5625  
Medium: 2300/2450 MHz MSL Medium parameters used (interpolated):  $f = 2310$  MHz;  $\sigma = 1.86$  mho/m;  $\epsilon_r = 50.8$ ;  $\rho = 1000$  kg/m<sup>3</sup>  
Phantom section: Flat Section

DASY4 Configuration:

- Probe: ES3DV3 - SN3341; ConvF(4.54, 4.54, 4.54);

- Sensor-Surface: 3mm (Mechanical Surface Detection)

- Electronics: DAE4 Sn432; Calibrated: 25/08/2015

- Phantom: SAM 12a (Site 57); Type: SAM 4.0; Serial: TP:1020

- Measurement SW: DASY4, V4.7 Build 80; Postprocessing SW: SEMCAD, V1.8 Build 186

**Back 1 RB Low - Hotspot - PB1/Area Scan (101x111x1):** Measurement grid: dx=12mm, dy=12mm

Maximum value of SAR (interpolated) = 0.270 mW/g

**Back 1 RB Low - Hotspot - PB1/Zoom Scan (7x7x7) (7x7x7)/Cube 0:** Measurement grid: dx=5mm, dy=5mm, dz=5mm

Reference Value = 8.39 V/m; Power Drift = 0.213 dB

Peak SAR (extrapolated) = 0.414 W/kg

**SAR(1 g) = 0.209 mW/g; SAR(10 g) = 0.108 mW/g**

Maximum value of SAR (measured) = 0.265 mW/g

Date: 16/05/2016

DUT: Model Name: Solarin; Model Number: SR0020-W; FCC ID: 2AIP8I

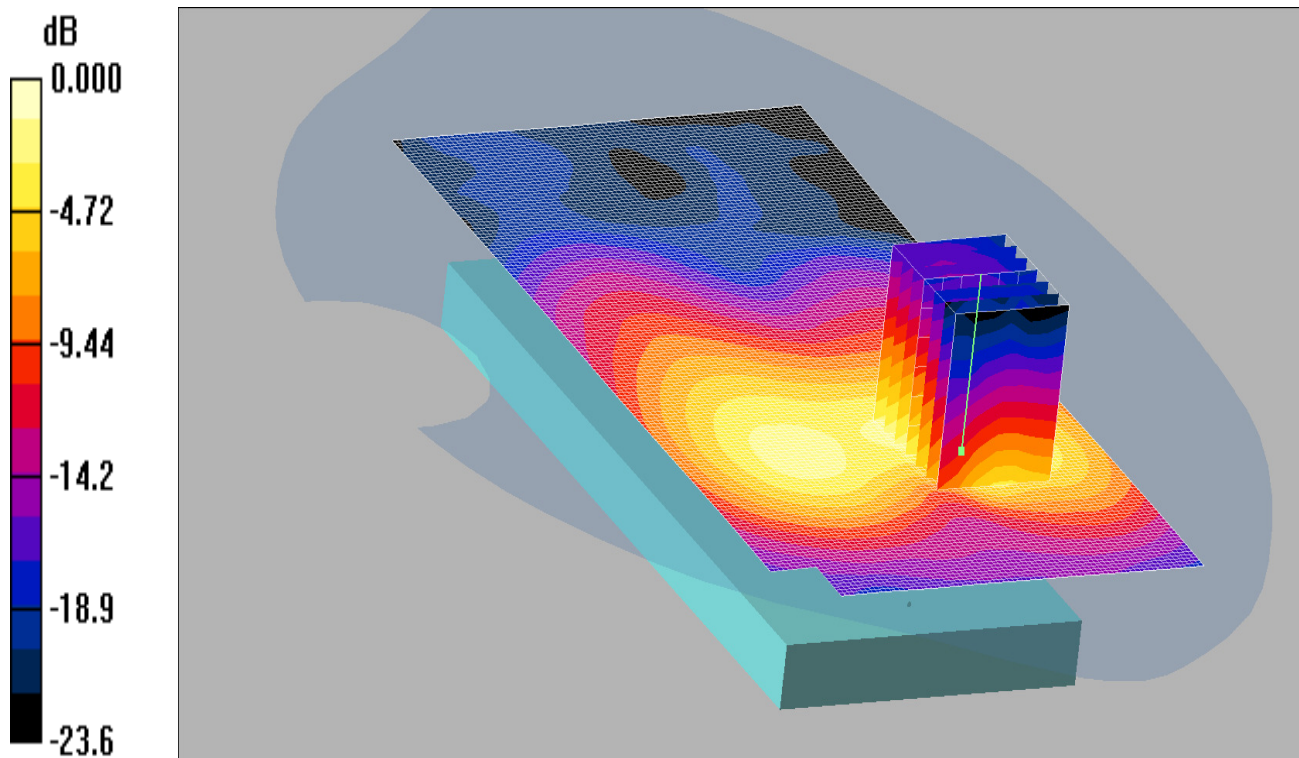

0 dB = 0.292mW/g

Communication System: LTE - Band 30/ 10MHz Channel; Frequency: 2310 MHz; Duty Cycle: 1:1.5625  
 Medium: 2300/2450 MHz MSL Medium parameters used (interpolated): f = 2310 MHz;  $\sigma = 1.87$  mho/m;  $\epsilon_r = 50.9$ ;  $\rho = 1000$  kg/m<sup>3</sup>  
 Phantom section: Flat Section

DASY4 Configuration:

- Probe: ES3DV3 - SN3341; ConvF(4.54, 4.54, 4.54);
- Sensor-Surface: 3mm (Mechanical Surface Detection)
- Electronics: DAE4 Sn432; Calibrated: 25/08/2015
- Phantom: SAM 12a (Site 57); Type: SAM 4.0; Serial: TP:1020
- Measurement SW: DASY4, V4.7 Build 80; Postprocessing SW: SEMCAD, V1.8 Build 186

**Back of EUT 1RB Low - Bodyworn – PB0 /Area Scan (91x161x1):** Measurement grid: dx=12mm, dy=12mm

Maximum value of SAR (interpolated) = 0.289 mW/g

**Back of EUT 1RB Low - Bodyworn – PB0 /Zoom Scan (7x7x7) (7x7x7)/Cube 0:** Measurement grid: dx=5mm, dy=5mm, dz=5mm

Reference Value = 2.64 V/m; Power Drift = -0.092 dB

Peak SAR (extrapolated) = 0.468 W/kg

**SAR(1 g) = 0.227 mW/g; SAR(10 g) = 0.112 mW/g**

Maximum value of SAR (measured) = 0.292 mW/g



Date: 29/04/2016

DUT: Model Name: Solarin; Model Number: SR0020-W; FCC ID: 2AIP8I

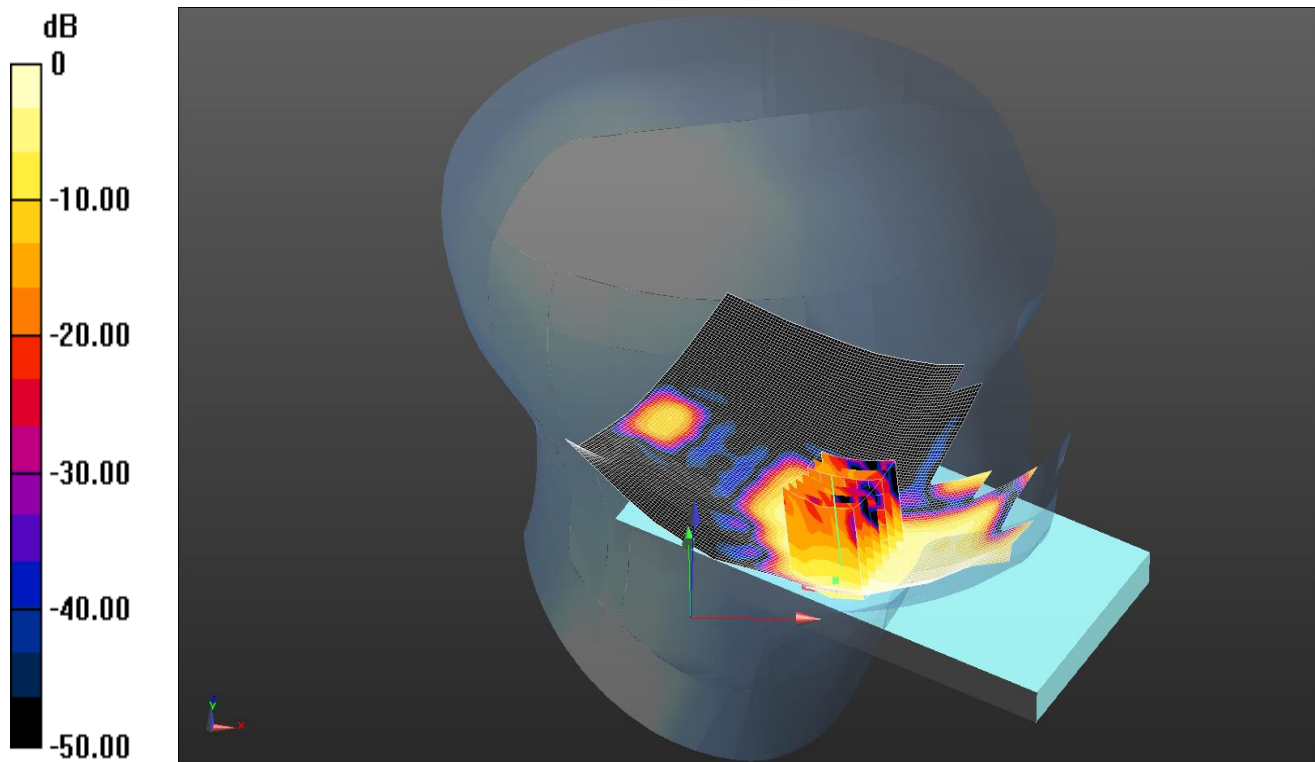

0 dB = 0.0374 W/kg = -14.27 dBW/kg

Communication System: UID 0, LTE TDD 20MHz(Duty Cycle 43%) (0); Frequency: 2593 MHz;Duty Cycle: 1:2.30675  
Medium: 2450 MHz HSL Medium parameters used (interpolated): f = 2593 MHz;  $\sigma = 1.971$  S/m;  $\epsilon_r = 38.232$ ;  $\rho = 1000$  kg/m<sup>3</sup>  
Phantom section: Left Section  
DASY4 Configuration:  
- Probe: ES3DV3 - SN3335; ConvF(4.33, 4.33, 4.33); Calibrated: 23/07/2015;  
- Sensor-Surface: 4mm (Mechanical Surface Detection), Sensor-Surface: 2mm (Mechanical Surface Detection)  
- Electronics: DAE4 Sn432; Calibrated: 25/08/2015  
- Phantom: SAMB (30deg probe tilt) with CRP v5.0; Type: QD000P40CD; Serial: TP:xxxx  
- ; SEMCAD X Version 14.6.10 (7164)

**Configuration/Touch Left 1RB Middle - Head - PBx 2 2 2/Area Scan (101x151x1):** Interpolated grid: dx=1.200 mm, dy=1.200 mm

Maximum value of SAR (interpolated) = 0.0321 W/kg

**Configuration/Touch Left 1RB Middle - Head - PBx 2 2 2/Zoom Scan (7x7x7) (7x7x7)/Cube 0:** Measurement grid: dx=5mm, dy=5mm, dz=5mm

Reference Value = 1.833 V/m; Power Drift = 1.02 dB

Peak SAR (extrapolated) = 0.0580 W/kg

**SAR(1 g) = 0.024 W/kg; SAR(10 g) = 0.012 W/kg**

Maximum value of SAR (measured) = 0.0374 W/kg



Date: 14/05/2016

**DUT: Model Name: Solarin; Model Number: SR0020-W; FCC ID: 2AIP8I**

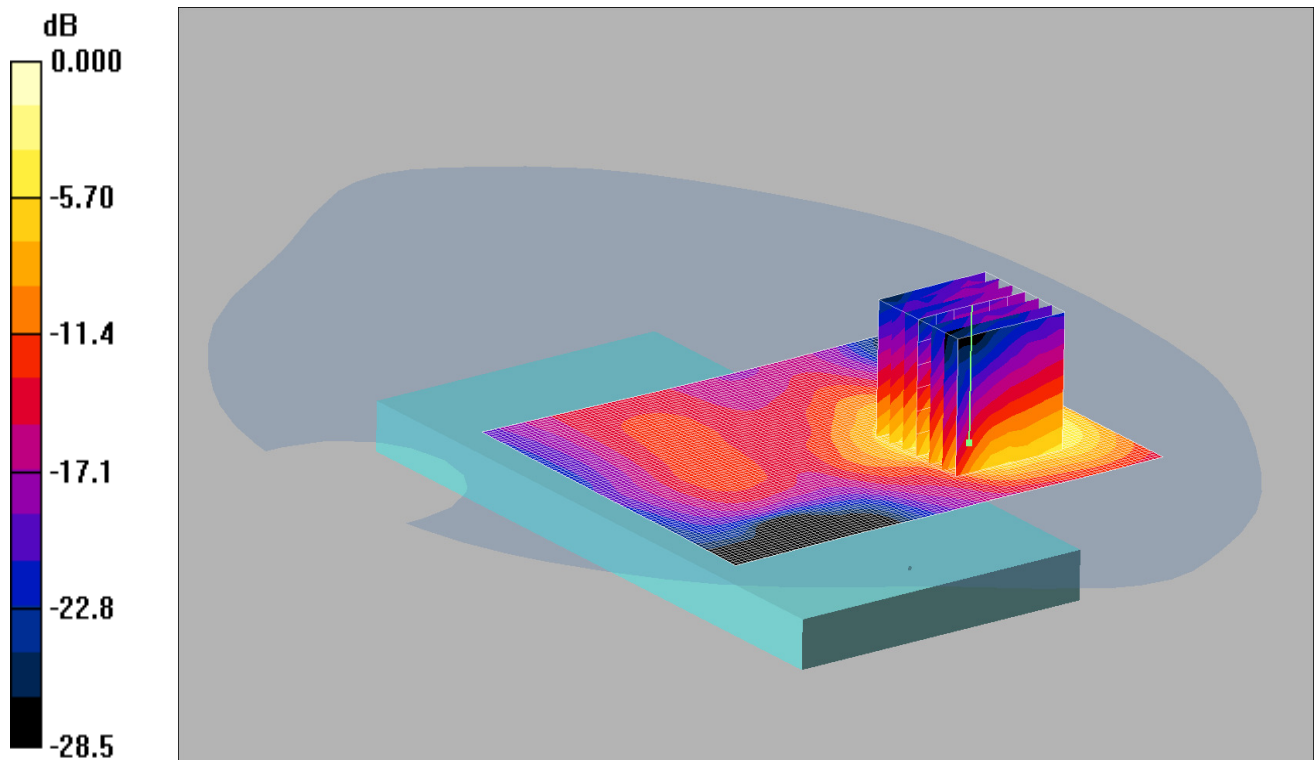

0 dB = 0.368mW/g

Communication System: LTE - Band 41/ 20MHz Channel; Frequency: 2593 MHz;Duty Cycle: 1:2.30675  
Medium: 2600 MHz MSL Medium parameters used (interpolated):  $f = 2593$  MHz;  $\sigma = 2.16$  mho/m;  $\epsilon_r = 50.5$ ;  $\rho = 1000$  kg/m<sup>3</sup>  
Phantom section: Flat Section

DASY4 Configuration:

- Probe: ES3DV3 - SN3341; ConvF(4.1, 4.1, 4.1);
- Sensor-Surface: 3mm (Mechanical Surface Detection)
- Electronics: DAE4 Sn432; Calibrated: 25/08/2015
- Phantom: SAM 12a (Site 57); Type: SAM 4.0; Serial: TP:1020
- Measurement SW: DASY4, V4.7 Build 80; Postprocessing SW: SEMCAD, V1.8 Build 186

**Back 1RB Middle - Hotspot - PBx/Area Scan (101x81x1):** Measurement grid: dx=12mm, dy=12mm

Maximum value of SAR (interpolated) = 0.354 mW/g

**Back 1RB Middle - Hotspot - PBx/Zoom Scan (7x7x7) (7x7x7)/Cube 0:** Measurement grid: dx=5mm, dy=5mm, dz=5mm

Reference Value = 7.02 V/m; Power Drift = 0.160 dB

Peak SAR (extrapolated) = 0.618 W/kg

**SAR(1 g) = 0.270 mW/g; SAR(10 g) = 0.132 mW/g**

Maximum value of SAR (measured) = 0.368 mW/g

Date: 23/04/2016

DUT: Model Name: Solarin; Model Number: SR0020-W; FCC ID: 2AIP8I

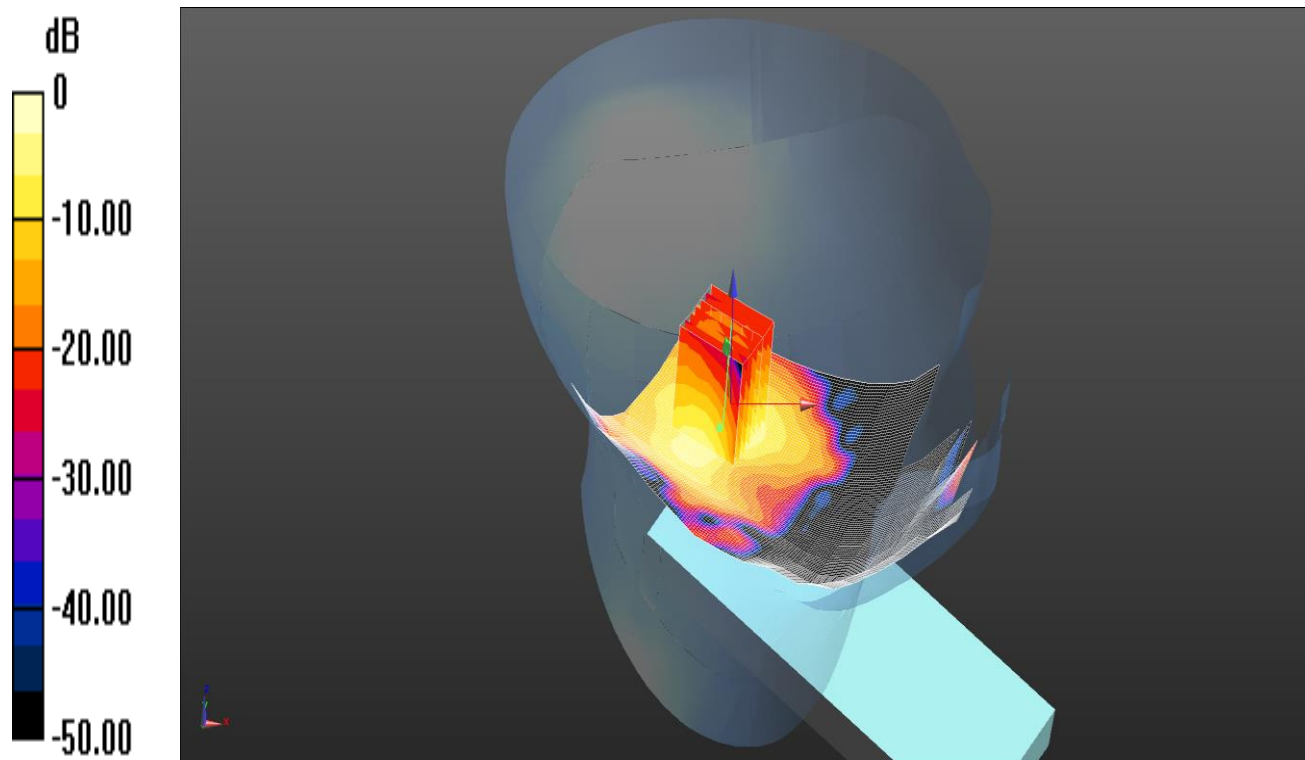

0 dB = 0.405 W/kg = -3.93 dBW/kg

Communication System: UID 0, WLAN 802.11 (0); Frequency: 2412 MHz; Duty Cycle: 1:1  
Medium: 2450 MHz HSL Medium parameters used (interpolated):  $f = 2412$  MHz;  $\sigma = 1.802$  S/m;  $\epsilon_r = 39.992$ ;  $\rho = 1000$  kg/m<sup>3</sup>  
Phantom section: Left Section  
DASY4 Configuration:  
- Probe: ES3DV3 - SN3335; ConvF(4.42, 4.42, 4.42); Calibrated: 23/07/2015;  
- Sensor-Surface: 4mm (Mechanical Surface Detection), Sensor-Surface: 2mm (Mechanical Surface Detection)  
- Electronics: DAE4 Sn432; Calibrated: 25/08/2015  
- Phantom: SAMB (30deg probe tilt) with CRP v5.0; Type: QD000P40CD; Serial: TP:xxxx  
- ; SEMCAD X Version 14.6.10 (7164)

**Configuration/Tilt Left 802.11b MIMO Ant 1&2 - Head - PBx/Area Scan (101x181x1):** Interpolated grid: dx=1.200 mm, dy=1.200 mm

Maximum value of SAR (interpolated) = 0.245 W/kg

**Configuration/Tilt Left 802.11b MIMO Ant 1&2 - Head - PBx/Ant1 Zoom Scan (7x7x7) (7x7x7)/Cube 0:** Measurement grid: dx=5mm, dy=5mm, dz=5mm

Reference Value = 14.251 V/m; Power Drift = -0.26 dB

Peak SAR (extrapolated) = 0.698 W/kg

**SAR(1 g) = 0.245 W/kg; SAR(10 g) = 0.109 W/kg**

Maximum value of SAR (measured) = 0.405 W/kg

Date: 18/05/2016

**DUT: Model Name: Solarin; Model Number: SR0020-W; FCC ID: 2AIP8I**

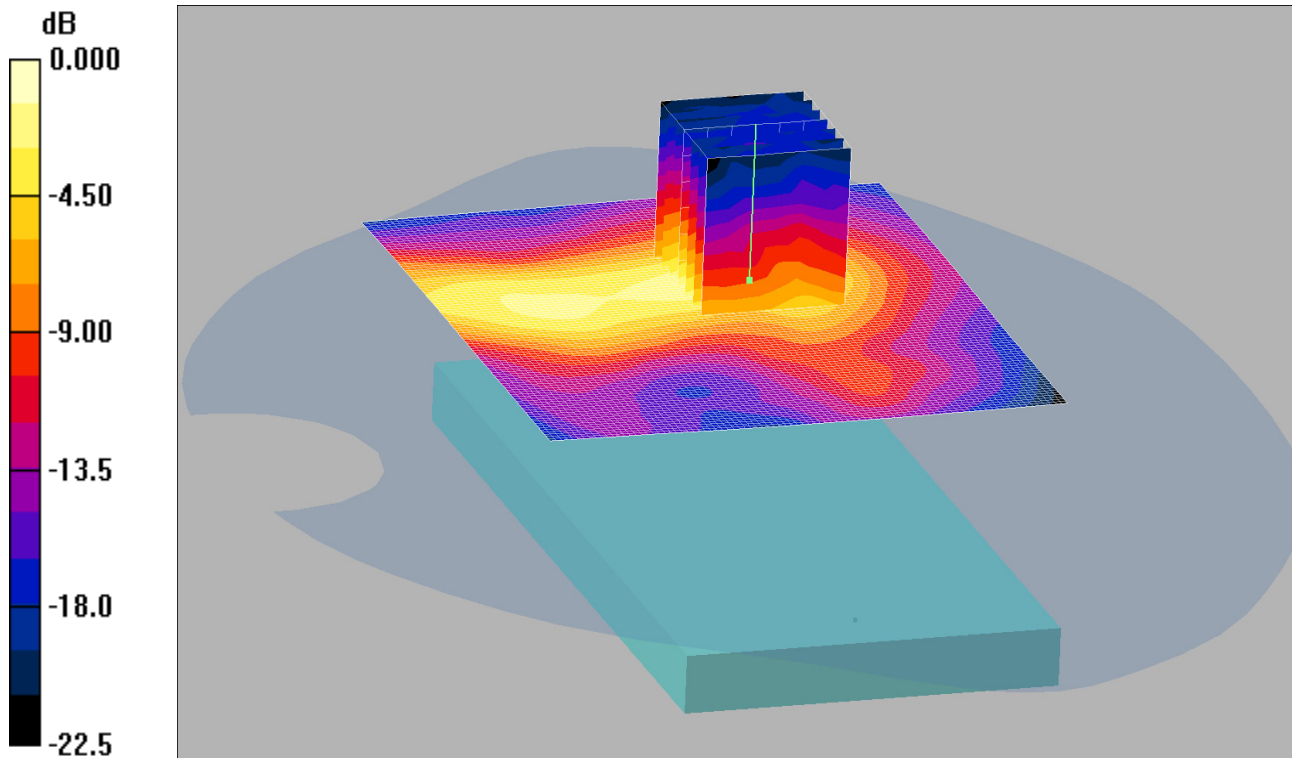

0 dB = 0.241mW/g

Communication System: WLAN; Frequency: 2437 MHz; Duty Cycle: 1:1  
Medium: 2450 MHz MSL Medium parameters used (interpolated):  $f = 2437$  MHz;  $\sigma = 2.01$  mho/m;  $\epsilon_r = 50.7$ ;  $\rho = 1000$  kg/m<sup>3</sup>  
Phantom section: Flat Section

DASY4 Configuration:

- Probe: ES3DV3 - SN3335; ConvF(4.31, 4.31, 4.31);

- Sensor-Surface: 3mm (Mechanical Surface Detection)

- Electronics: DAE4 Sn432; Calibrated: 25/08/2015

- Phantom: SAM 12a (Site 57); Type: SAM 4.0; Serial: TP:1020

- Measurement SW: DASY4, V4.7 Build 80; Postprocessing SW: SEMCAD, V1.8 Build 186

**Back - Hotspot - PBx 2/Area Scan (91x101x1):** Measurement grid: dx=12mm, dy=12mm

Maximum value of SAR (interpolated) = 0.234 mW/g

**Back - Hotspot - PBx 2/Zoom Scan (7x7x7) (7x7x7)/Cube 0:** Measurement grid: dx=5mm, dy=5mm, dz=5mm

Reference Value = 7.69 V/m; Power Drift = 0.184 dB

Peak SAR (extrapolated) = 0.398 W/kg

**SAR(1 g) = 0.179 mW/g; SAR(10 g) = 0.085 mW/g**

Maximum value of SAR (measured) = 0.241 mW/g

Date: 21/04/16

DUT: Model Name: Solarin; Model Number: SR0020-W; FCC ID: 2AIP8I

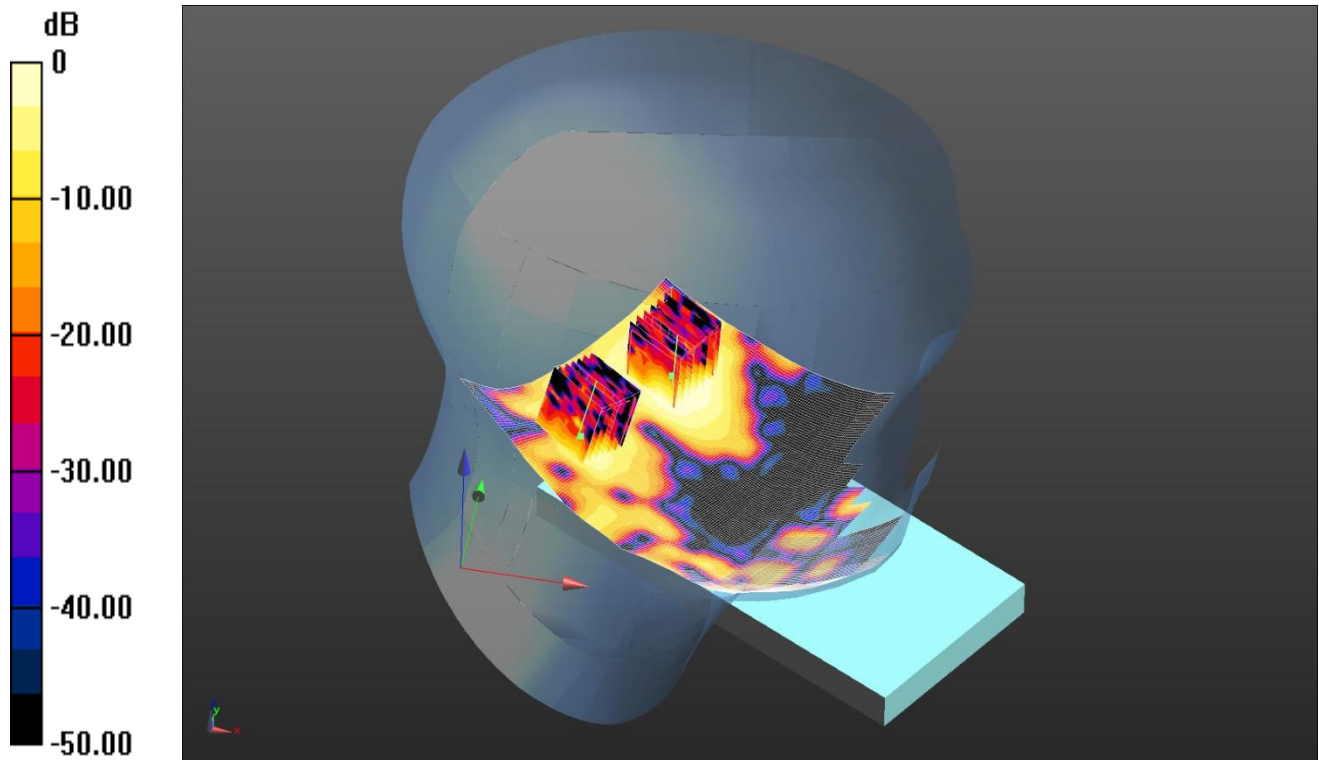

0 dB = 0.525 W/kg = -2.80 dBW/kg

Communication System: UID 0, WLAN 802.11 (0); Frequency: 5500 MHz; Duty Cycle: 1:1  
Medium: 5250/5600/5750 MHz HSL Medium parameters used:  $f = 5500$  MHz;  $\sigma = 4.921$  S/m;  $\epsilon_r = 34.234$ ;  $\rho = 1000$  kg/m<sup>3</sup>  
Phantom section: Left Section

DASY4 Configuration:

- Probe: EX3DV4 - SN3994; ConvF(4.5, 4.5, 4.5); Calibrated: 21/03/16;
- Sensor-Surface: 2mm (Mechanical Surface Detection)
- Electronics: DAE4 Sn431; Calibrated: 17/11/15
- Phantom: SAM (20deg probe tilt) with CRP v4.0; Type: QD000P40CC; Serial: TP:xxxx
- ; SEMCAD X Version 14.6.10 (7331)

**Configuration/Touch Left 802.11a MIMO Ant 1&2 - Head - PBx/Area Scan (121x191x1):** Interpolated grid: dx=1.000 mm, dy=1.000 mm

Maximum value of SAR (interpolated) = 0.731 W/kg

**Configuration/Touch Left 802.11a MIMO Ant 1&2 - Head - PBx/Ant1 Zoom Scan (7x7x12) (7x7x12)/Cube 0:**

Measurement grid: dx=4mm, dy=4mm, dz=2mm

Reference Value = 13.17 V/m; Power Drift = 0.03 dB

Peak SAR (extrapolated) = 3.38 W/kg

**SAR(1 g) = 0.422 W/kg; SAR(10 g) = 0.130 W/kg**

Maximum value of SAR (measured) = 0.925 W/kg

**Configuration/Touch Left 802.11a MIMO Ant 1&2 - Head - PBx/Ant2 Zoom Scan (7x7x12) 2 (7x7x12)/Cube 0:**

Measurement grid: dx=4mm, dy=4mm, dz=2mm

Reference Value = 13.17 V/m; Power Drift = 0.03 dB

Peak SAR (extrapolated) = 0.915 W/kg

**SAR(1 g) = 0.255 W/kg; SAR(10 g) = 0.076 W/kg**

Maximum value of SAR (measured) = 0.525 W/kg

Note: DASY system is configured to measure any secondary maxima that are within 2dB of the measured SAR level.

Date: 04/05/16

DUT: Model Name: Solarin; Model Number: SR0020-W; FCC ID: 2AIP8I

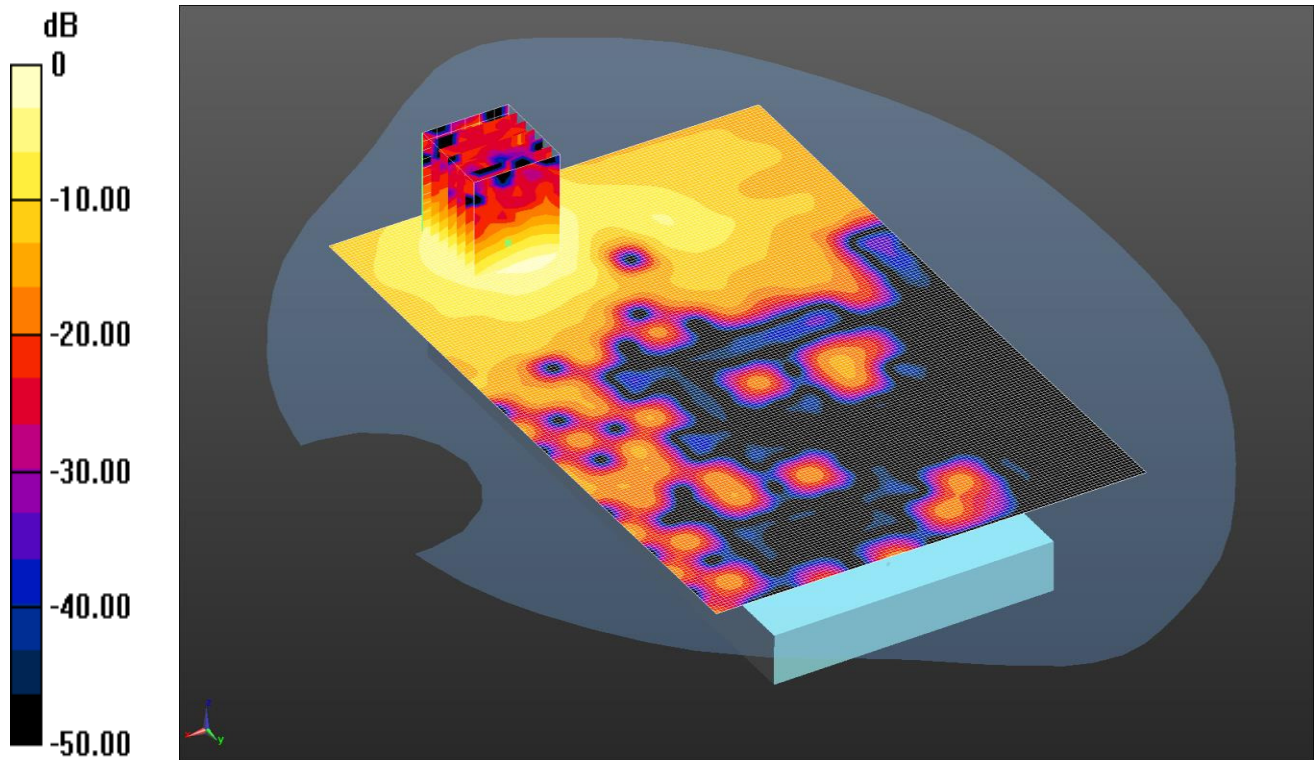

0 dB = 0.893 W/kg = -0.49 dBW/kg

Communication System: UID 0, WLAN 802.11 (0); Frequency: 5765 MHz; Duty Cycle: 1:1  
Medium: 5250/5600/5750 MHz MSL Medium parameters used (interpolated):  $f = 5765$  MHz;  $\sigma = 6.067$  S/m;  $\epsilon_r = 48.056$ ;  $\rho = 1000$  kg/m<sup>3</sup>

Phantom section: Flat Section

DASY4 Configuration:

- Probe: EX3DV4 - SN3814; ConvF(3.99, 3.99, 3.99); Calibrated: 06/10/15;
- Sensor-Surface: 2mm (Mechanical Surface Detection)
- Electronics: DAE4 Sn431; Calibrated: 17/11/15
- Phantom: SAM (30deg probe tilt) with CRP v5.0; Type: QD000P40CD; Serial: TP:xxxx
- ; SEMCAD X Version 14.6.10 (7331)

**Configuration/Back 802.11a MIMO Ant 1&2 - Hotspot - PBx/Area Scan (121x181x1):** Interpolated grid: dx=1.000 mm, dy=1.000 mm

Maximum value of SAR (interpolated) = 0.904 W/kg

**Configuration/Back 802.11a MIMO Ant 1&2 - Hotspot - PBx/Zoom Scan (7x7x12)/Cube 0:** Measurement grid: dx=4mm, dy=4mm, dz=2mm

Reference Value = 10.56 V/m; Power Drift = -0.08 dB

Peak SAR (extrapolated) = 1.89 W/kg

**SAR(1 g) = 0.469 W/kg; SAR(10 g) = 0.166 W/kg**

Maximum value of SAR (measured) = 0.893 W/kg



Date: 20/05/2016

DUT: Model Name: Solarin; Model Number: SR0020-W; FCC ID: 2AIP8I

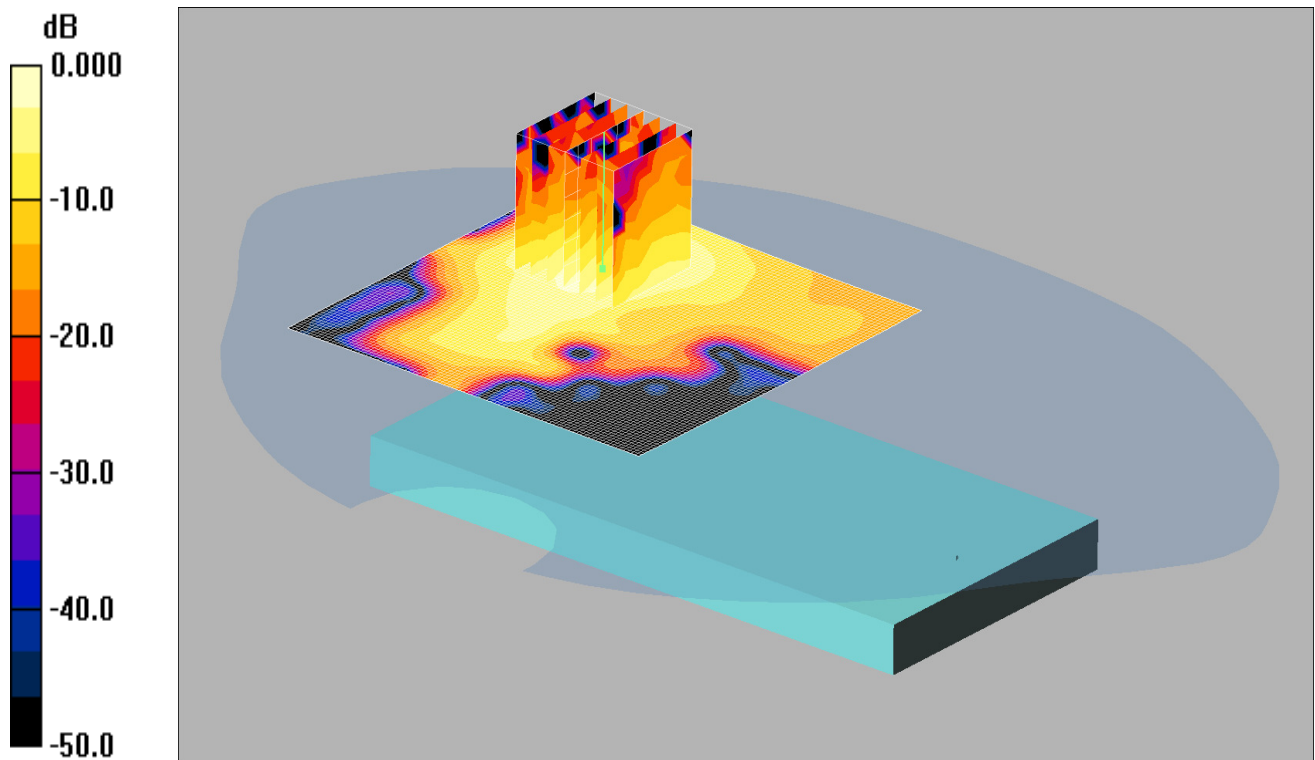

0 dB = 0.037mW/g

Communication System: Bluetooth; Frequency: 2480 MHz; Duty Cycle: 1:1  
Medium: 2300/2450 MHz MSL Medium parameters used (interpolated):  $f = 2480$  MHz;  $\sigma = 2.05$  mho/m;  $\epsilon_r = 50.3$ ;  $\rho = 1000$  kg/m<sup>3</sup>  
Phantom section: Flat Section

DASY4 Configuration:

- Probe: ES3DV3 - SN3341; ConvF(4.31, 4.31, 4.31);

- Sensor-Surface: 3mm (Mechanical Surface Detection)

- Electronics: DAE4 Sn432; Calibrated: 25/08/2015

- Phantom: SAM 12a (Site 57); Type: SAM 4.0; Serial: TP:1020

- Measurement SW: DASY4, V4.7 Build 80; Postprocessing SW: SEMCAD, V1.8 Build 186

**Back - Bluetooth - Hotspot - PBx/Area Scan (91x91x1):** Measurement grid: dx=12mm, dy=12mm

Maximum value of SAR (interpolated) = 0.035 mW/g

**Back - Bluetooth - Hotspot - PBx/Zoom Scan (7x7x7) (7x7x7)/Cube 0:** Measurement grid: dx=5mm, dy=5mm, dz=5mm

Reference Value = 4.13 V/m; Power Drift = 0.032 dB

Peak SAR (extrapolated) = 0.064 W/kg

**SAR(1 g) = 0.028 mW/g; SAR(10 g) = 0.013 mW/g**

Maximum value of SAR (measured) = 0.037 mW/g