



TEST REPORT

Test Report No. : UL-RPT-RP11066287JD24A

Manufacturer : Flextronics International Sweden AB
Model No. : SR0020-W
FCC ID : 2AIP8I
Technology : LTE – Band 41
Test Standard(s) : FCC Parts 27.50(h)(2), 27.50(d)(5) & 27.54

1. This test report shall not be reproduced in full or partial, without the written approval of UL VS LTD.
2. The results in this report apply only to the sample(s) tested.
3. The sample tested is in compliance with the above standard(s).
4. The test results in this report are traceable to the national or international standards.
5. Version 1.0

Date of Issue: 25 June 2016

Checked by:

Sarah Williams
Engineer, Radio Laboratory

Company Signatory:

Steven White
Service Lead, Radio Laboratory
UL VS LTD



This laboratory is accredited by UKAS.
The tests reported herein have been
performed in accordance with its' terms
of accreditation.

UL VS LTD

Pavilion A, Ashwood Park, Ashwood Way, Basingstoke, Hampshire, RG23 8BG, UK
Telephone: +44 (0)1256 312000
Facsimile: +44 (0)1256 312001

This page has been left intentionally blank.

Table of Contents

1. Customer/Manufacturer Information	4
1.1. Customer Information	4
1.2. Manufacturer Information	4
2. Summary of Testing.....	5
2.1. General Information	5
2.2. Summary of Test Results	5
2.3. Methods and Procedures	5
2.4. Deviations from the Test Specification	5
3. Equipment Under Test (EUT)	6
3.1. Identification of Equipment Under Test (EUT)	6
3.2. Description of EUT	6
3.3. Modifications Incorporated in the EUT	6
3.4. Additional Information Related to Testing	7
3.5. Support Equipment	7
4. Operation and Monitoring of the EUT during Testing	8
4.1. Operating Modes	8
4.2. Configuration and Peripherals	8
4.3. Resource Block Allocation	8
5. Measurements, Examinations and Derived Results.....	9
5.1. General Comments	9
5.2. Test Results	10
5.2.1. Transmitter Output Power (EIRP)	10
5.2.2. Transmitter Peak-To-Average Ratio (PAR)	18
5.2.3. Transmitter Occupied Bandwidth	26
5.2.4. Transmitter Frequency Stability (Temperature Variation)	36
5.2.5. Transmitter Frequency Stability (Voltage Variation)	38
6. Measurement Uncertainty	40
7. Report Revision History	41

1. Customer/Manufacturer Information

1.1. Customer Information

Company Name:	Sirin Labs AG
Address:	Muhlentalstrasse 2 8200 Schaffhausen Switzerland

1.2. Manufacturer Information







Manufacturer Name:	Flextronics International Sweden AB
Address:	Datalinjen 3A SE – 583 30 Linköping Sweden

2. Summary of Testing

2.1. General Information

Specification Reference:	47CFR27
Specification Title:	Code of Federal Regulations Volume 47 (Telecommunications): Part 27 Subpart C (Miscellaneous Wireless Communication Services)
Site Registration:	209735
Location of Testing:	UL VS LTD, Unit 3 Horizon, Wade Road, Kingsland Business Park, Basingstoke, Hampshire, RG24 8AH, United Kingdom
Test Dates:	14 May 2016 to 31 May 2016

2.2. Summary of Test Results

FCC Reference (47CFR)	Measurement	Result
2.1046 / 27.50(h)(2)	Transmitter Output Power (EIRP)	
27.50(d)(5)	Transmitter Peak-To-Average Ratio (PAR)	
2.1049	Transmitter Occupied Bandwidth	
2.1055 / 27.54	Transmitter Frequency Stability (Temperature and Voltage Variation)	
Key to Results		
 = Complied  = Did not comply		

2.3. Methods and Procedures

Reference:	ANSI/TIA-603-D-2010
Title:	Land Mobile FM or PM Communications Equipment, Measurements and performance Standards
Reference:	FCC KDB 971168 D01 v02r02, 17 October 2014
Title:	Measurement Guidance for Certification of Licensed Digital Transmitters

2.4. Deviations from the Test Specification

For the measurements contained within this test report, there were no deviations from, additions to, or exclusions from the test specification identified above.

3. Equipment Under Test (EUT)

3.1. Identification of Equipment Under Test (EUT)

Brand Name:	SOLARIN
Model Number:	SR0020-W
Test Sample Serial Number:	0030 (<i>Conducted Sample</i>)
Test Sample IMEI:	357232070003163
Hardware Version:	TP1
Software Version:	LRC1TA.1.0.2.3
Handset Cover Material:	Technical leather with titanium coating
FCC ID:	2AIP8I

3.2. Description of EUT

The equipment under test was a Mobile device supporting Cellular, WLAN, BT, BTLE, RFID & GPS Technologies.

3.3. Modifications Incorporated in the EUT

No modifications were applied to the EUT during testing.

3.4. Additional Information Related to Testing

Tested Technology:	LTE Band 41		
Type of Equipment	Transceiver		
Channel Bandwidth:	5, 10, 15 & 20 MHz		
Modulation Type:	QPSK & 16QAM		
Duty Cycle:	50%		
Antenna Type:	Integral		
Antenna Gain:	-2.77 dBi		
Power Supply Requirement:	Nominal	3.9 VDC	
	Minimum	3.5 VDC	
	Maximum	4.4 VDC	
Transmit Frequency Range:	2496 MHz to 2690 MHz		
Channels Tested:	Channel Bandwidth (MHz)	N_{ul}	Frequency of Uplink (MHz)
Bottom Channel	5	39675	2498.5
	10	39700	2501.0
	15	39725	2503.5
	20	39750	2506.0
Middle Channel	All	40620	2593.0
Top Channel	5	41565	2687.5
	10	41540	2685.0
	15	41515	2682.5
	20	41490	2680.0

3.5. Support Equipment

No support equipment was used for the tests shown in this report.

4. Operation and Monitoring of the EUT during Testing

4.1. Operating Modes

The EUT was tested in the following operating mode(s):

- Transmit Mode - The EUT was set to transmit with maximum output power using the required channel bandwidth. QPSK and 16QAM modulations were both tested, with Resource Block allocation as detailed in section 4.3.

4.2. Configuration and Peripherals

The EUT was tested in the following configuration(s):

- The EUT was connected to a Rohde and Schwarz CMW500 LTE system simulator, operating in a transceiver mode.
- Conducted measurements were performed using a conducted sample supplied by the customer. Short 4-wire DC flying leads were connected internally to the device in place of the battery, and exiting through a hole in the casing. These leads were then extended through a connector interface to a laboratory DC power supply.
- For conducted cellular measurements, the EUT RF conducted port was a temporary SMA connector that was connected internally in place of the pcb antenna. The loss of the internal connection to the connector was accounted for in calculations.
- For the conducted tests in this report, the antenna port measured was identified by the manufacturer as Antenna #1.

4.3. Resource Block Allocation

Channel Bandwidth (MHz)	Maximum No. of Resource Blocks	Resource Block / Offset Number							
		Sub Test 1		Sub Test 2		Sub Test 3		Sub Test 4	
		RB	Offset	RB	Offset	RB	Offset	RB	Offset
5	25	1	0	1	24	12	6	25	0
10	50	1	0	1	49	25	12	50	0
15	75	1	0	1	74	36	18	75	0
20	100	1	0	1	99	50	25	100	0

Transmitter Output Power was carried out using sub tests 1, 2, 3 and 4, with both QPSK and 16QAM modulation schemes.

Transmitter Occupied Bandwidth was carried out using sub test 4, for both QPSK and 16QAM modulation schemes.

Transmitter Frequency Stability test was carried out with sub test 4, with a channel bandwidth of 5 MHz only.

5. Measurements, Examinations and Derived Results

5.1. General Comments

Measurement uncertainties are evaluated in accordance with current best practice. Our reported expanded uncertainties are based on standard uncertainties, which are multiplied by an appropriate coverage factor to provide a statistical confidence level of approximately 95%. Please refer to *Section 6* for Measurement Uncertainty details.

In accordance with UKAS requirements all the measurement equipment is on a calibration schedule. All equipment was within the calibration period on the date of testing.

5.2. Test Results

5.2.1. Transmitter Output Power (EIRP)

Test Summary:

Test Engineer:	Keith Tucker	Test Date:	14 May 2016
Test Sample IMEI:	357232070003163		

FCC Reference:	Parts 2.1046, 27.50(h)(2)
Test Method Used:	KDB 971168 Section 2.2 footnote 1 & Notes below

Environmental Conditions:

Temperature (°C):	24
Relative Humidity (%):	46

Note(s):

1. The customer stated that the antenna gain is -2.8 dBi.
2. Conducted average power was measured using a calibrated Rohde and Schwarz CMW 500 Wideband Radio Communication Tester. As the duty cycle was less than 98%, the measurement was gated, such that the power was measured only over the active transmission burst interval.
3. Measurements were performed with the EUT transmitting with QPSK and 16QAM modulation schemes, with resource blocks settings as detailed in section 4.3 of this report.

Test setup:

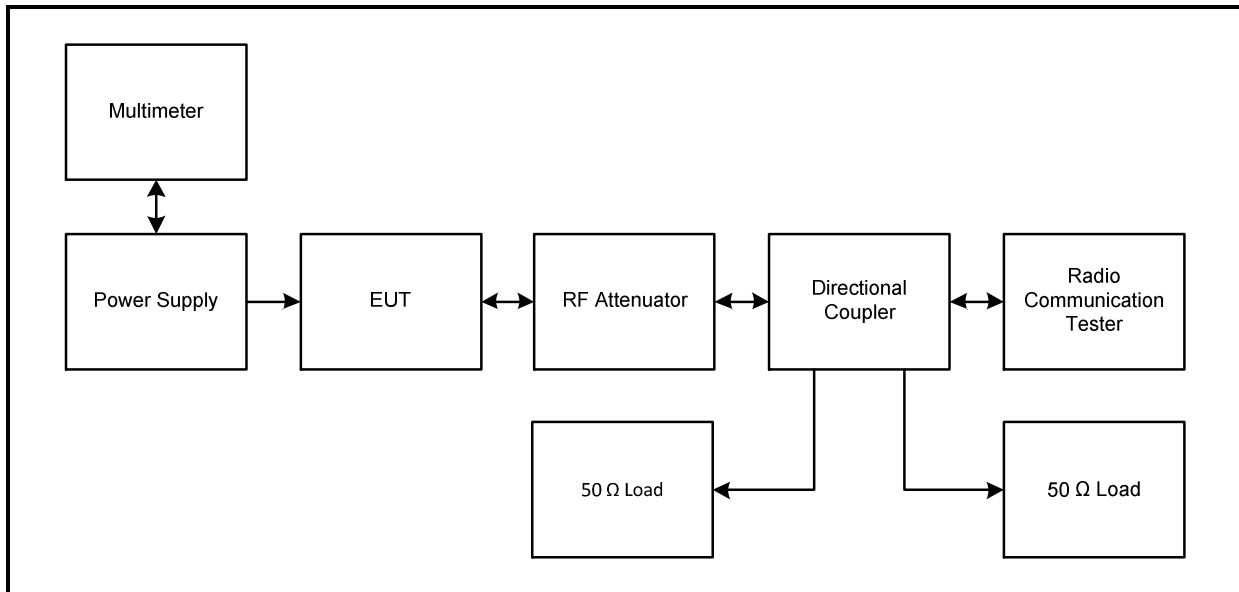

Transmitter Output Power (EIRP) (continued)**Results: 5 MHz Channel Bandwidth / Bottom Channel / QPSK**

Frequency (MHz)	Resource Block(s)	Resource Block Offset	Conducted RF Power (dBm)	Antenna Gain (dBi)	EIRP (dBm)	EIRP Limit (dBm)	Margin (dB)	Result
2498.5	25	0	21.9	-2.8	19.1	33.0	13.9	Complied
2498.5	12	6	22.0	-2.8	19.2	33.0	13.8	Complied
2498.5	1	0	21.8	-2.8	19.0	33.0	14.0	Complied
2498.5	1	24	22.2	-2.8	19.4	33.0	13.6	Complied

Results: 5 MHz Channel Bandwidth / Bottom Channel / 16QAM

Frequency (MHz)	Resource Block(s)	Resource Block Offset	Conducted RF Power (dBm)	Antenna Gain (dBi)	EIRP (dBm)	EIRP Limit (dBm)	Margin (dB)	Result
2498.5	25	0	21.0	-2.8	18.2	33.0	14.8	Complied
2498.5	12	6	21.1	-2.8	18.3	33.0	14.7	Complied
2498.5	1	0	21.2	-2.8	18.4	33.0	14.6	Complied
2498.5	1	24	21.5	-2.8	18.7	33.0	14.3	Complied

Results: 5 MHz Channel Bandwidth / Middle Channel / QPSK

Frequency (MHz)	Resource Block(s)	Resource Block Offset	Conducted RF Power (dBm)	Antenna Gain (dBi)	EIRP (dBm)	EIRP Limit (dBm)	Margin (dB)	Result
2593.0	25	0	21.7	-2.8	18.9	33.0	14.1	Complied
2593.0	12	6	21.9	-2.8	19.1	33.0	13.9	Complied
2593.0	1	0	22.8	-2.8	20.0	33.0	13.0	Complied
2593.0	1	24	22.5	-2.8	19.7	33.0	13.3	Complied

Results: 5 MHz Channel Bandwidth / Middle Channel / 16QAM

Frequency (MHz)	Resource Block(s)	Resource Block Offset	Conducted RF Power (dBm)	Antenna Gain (dBi)	EIRP (dBm)	EIRP Limit (dBm)	Margin (dB)	Result
2593.0	25	0	20.8	-2.8	18.0	33.0	15.0	Complied
2593.0	12	6	21.0	-2.8	18.2	33.0	14.8	Complied
2593.0	1	0	22.1	-2.8	19.3	33.0	13.7	Complied
2593.0	1	24	22.1	-2.8	19.3	33.0	13.7	Complied

Transmitter Output Power (EIRP) (continued)**Results: 5 MHz Channel Bandwidth / Top Channel / QPSK**

Frequency (MHz)	Resource Block(s)	Resource Block Offset	Conducted RF Power (dBm)	Antenna Gain (dBi)	EIRP (dBm)	EIRP Limit (dBm)	Margin (dB)	Result
2687.5	25	0	22.4	-2.8	19.6	33.0	13.4	Complied
2687.5	12	6	22.4	-2.8	19.6	33.0	13.4	Complied
2687.5	1	0	22.2	-2.8	19.4	33.0	13.6	Complied
2687.5	1	24	21.8	-2.8	19.0	33.0	14.0	Complied

Results: 5 MHz Channel Bandwidth / Top Channel / 16QAM

Frequency (MHz)	Resource Block(s)	Resource Block Offset	Conducted RF Power (dBm)	Antenna Gain (dBi)	EIRP (dBm)	EIRP Limit (dBm)	Margin (dB)	Result
2687.5	25	0	21.3	-2.8	18.5	33.0	14.5	Complied
2687.5	12	6	21.3	-2.8	18.5	33.0	14.5	Complied
2687.5	1	0	21.3	-2.8	18.5	33.0	14.5	Complied
2687.5	1	24	21.0	-2.8	18.2	33.0	14.8	Complied

Results: 10 MHz Channel Bandwidth / Bottom Channel / QPSK

Frequency (MHz)	Resource Block(s)	Resource Block Offset	Conducted RF Power (dBm)	Antenna Gain (dBi)	EIRP (dBm)	EIRP Limit (dBm)	Margin (dB)	Result
2501.0	50	0	22.0	-2.8	19.2	33.0	13.8	Complied
2501.0	25	12	22.0	-2.8	19.2	33.0	13.8	Complied
2501.0	1	0	22.0	-2.8	19.2	33.0	13.8	Complied
2501.0	1	49	22.5	-2.8	19.7	33.0	13.3	Complied

Results: 10 MHz Channel Bandwidth / Bottom Channel / 16QAM

Frequency (MHz)	Resource Block(s)	Resource Block Offset	Conducted RF Power (dBm)	Antenna Gain (dBi)	EIRP (dBm)	EIRP Limit (dBm)	Margin (dB)	Result
2501.0	50	0	21.0	-2.8	18.2	33.0	14.8	Complied
2501.0	25	12	21.1	-2.8	18.3	33.0	14.7	Complied
2501.0	1	0	21.1	-2.8	18.3	33.0	14.7	Complied
2501.0	1	49	21.9	-2.8	19.1	33.0	13.9	Complied

Transmitter Output Power (EIRP) (continued)**Results: 10 MHz Channel Bandwidth / Middle Channel / QPSK**

Frequency (MHz)	Resource Block(s)	Resource Block Offset	Conducted RF Power (dBm)	Antenna Gain (dBi)	EIRP (dBm)	EIRP Limit (dBm)	Margin (dB)	Result
2593.0	50	0	21.7	-2.8	18.9	33.0	14.1	Complied
2593.0	25	12	21.8	-2.8	19.0	33.0	14.0	Complied
2593.0	1	0	22.5	-2.8	19.7	33.0	13.3	Complied
2593.0	1	49	22.3	-2.8	19.5	33.0	13.5	Complied

Results: 10 MHz Channel Bandwidth / Middle Channel / 16QAM

Frequency (MHz)	Resource Block(s)	Resource Block Offset	Conducted RF Power (dBm)	Antenna Gain (dBi)	EIRP (dBm)	EIRP Limit (dBm)	Margin (dB)	Result
2593.0	50	0	20.8	-2.8	18.0	33.0	15.0	Complied
2593.0	25	12	20.8	-2.8	18.0	33.0	15.0	Complied
2593.0	1	0	22.4	-2.8	19.6	33.0	13.4	Complied
2593.0	1	49	22.3	-2.8	19.5	33.0	13.5	Complied

Results: 10 MHz Channel Bandwidth / Top Channel / QPSK

Frequency (MHz)	Resource Block(s)	Resource Block Offset	Conducted RF Power (dBm)	Antenna Gain (dBi)	EIRP (dBm)	EIRP Limit (dBm)	Margin (dB)	Result
2685.0	50	0	22.2	-2.8	19.4	33.0	13.6	Complied
2685.0	25	12	22.2	-2.8	19.4	33.0	13.6	Complied
2685.0	1	0	22.4	-2.8	19.6	33.0	13.4	Complied
2685.0	1	49	21.7	-2.8	18.9	33.0	14.1	Complied

Results: 10 MHz Channel Bandwidth / Top Channel / 16QAM

Frequency (MHz)	Resource Block(s)	Resource Block Offset	Conducted RF Power (dBm)	Antenna Gain (dBi)	EIRP (dBm)	EIRP Limit (dBm)	Margin (dB)	Result
2685.0	50	0	21.2	-2.8	18.4	33.0	14.6	Complied
2685.0	25	12	21.3	-2.8	18.5	33.0	14.5	Complied
2685.0	1	0	21.5	-2.8	18.7	33.0	14.3	Complied
2685.0	1	49	20.9	-2.8	18.1	33.0	14.9	Complied

Transmitter Output Power (EIRP) (continued)**Results: 15 MHz Channel Bandwidth / Bottom Channel / QPSK**

Frequency (MHz)	Resource Block(s)	Resource Block Offset	Conducted RF Power (dBm)	Antenna Gain (dBi)	EIRP (dBm)	EIRP Limit (dBm)	Margin (dB)	Result
2503.5	75	0	21.8	-2.8	19.0	33.0	14.0	Complied
2503.5	36	18	22.0	-2.8	19.2	33.0	13.8	Complied
2503.5	1	0	22.3	-2.8	19.5	33.0	13.5	Complied
2503.5	1	74	22.4	-2.8	19.6	33.0	13.4	Complied

Results: 15 MHz Channel Bandwidth / Bottom Channel / 16QAM

Frequency (MHz)	Resource Block(s)	Resource Block Offset	Conducted RF Power (dBm)	Antenna Gain (dBi)	EIRP (dBm)	EIRP Limit (dBm)	Margin (dB)	Result
2503.5	75	0	21.0	-2.8	18.2	33.0	14.8	Complied
2503.5	36	18	20.9	-2.8	18.1	33.0	14.9	Complied
2503.5	1	0	21.4	-2.8	18.6	33.0	14.4	Complied
2503.5	1	74	21.6	-2.8	18.8	33.0	14.2	Complied

Results: 15 MHz Channel Bandwidth / Middle Channel / QPSK

Frequency (MHz)	Resource Block(s)	Resource Block Offset	Conducted RF Power (dBm)	Antenna Gain (dBi)	EIRP (dBm)	EIRP Limit (dBm)	Margin (dB)	Result
2593.0	75	0	21.7	-2.8	18.9	33.0	14.1	Complied
2593.0	36	18	21.8	-2.8	19.0	33.0	14.0	Complied
2593.0	1	0	23.2	-2.8	20.4	33.0	12.6	Complied
2593.0	1	74	22.7	-2.8	19.9	33.0	13.1	Complied

Results: 15 MHz Channel Bandwidth / Middle Channel / 16QAM

Frequency (MHz)	Resource Block(s)	Resource Block Offset	Conducted RF Power (dBm)	Antenna Gain (dBi)	EIRP (dBm)	EIRP Limit (dBm)	Margin (dB)	Result
2593.0	75	0	20.8	-2.8	18.0	33.0	15.0	Complied
2593.0	36	18	20.9	-2.8	18.1	33.0	14.9	Complied
2593.0	1	0	22.3	-2.8	19.5	33.0	13.5	Complied
2593.0	1	74	21.7	-2.8	18.9	33.0	14.1	Complied

Transmitter Output Power (EIRP) (continued)**Results: 15 MHz Channel Bandwidth / Top Channel / QPSK**

Frequency (MHz)	Resource Block(s)	Resource Block Offset	Conducted RF Power (dBm)	Antenna Gain (dBi)	EIRP (dBm)	EIRP Limit (dBm)	Margin (dB)	Result
2682.5	75	0	22.2	-2.8	19.4	33.0	13.6	Complied
2682.5	36	18	22.3	-2.8	19.5	33.0	13.5	Complied
2682.5	1	0	22.7	-2.8	19.9	33.0	13.1	Complied
2682.5	1	74	21.9	-2.8	19.1	33.0	13.9	Complied

Results: 15 MHz Channel Bandwidth / Top Channel / 16QAM

Frequency (MHz)	Resource Block(s)	Resource Block Offset	Conducted RF Power (dBm)	Antenna Gain (dBi)	EIRP (dBm)	EIRP Limit (dBm)	Margin (dB)	Result
2682.5	75	0	21.2	-2.8	18.4	33.0	14.6	Complied
2682.5	36	18	21.3	-2.8	18.5	33.0	14.5	Complied
2682.5	1	0	22.3	-2.8	19.5	33.0	13.5	Complied
2682.5	1	74	21.6	-2.8	18.8	33.0	14.2	Complied

Results: 20 MHz Channel Bandwidth / Bottom Channel / QPSK

Frequency (MHz)	Resource Block(s)	Resource Block Offset	Conducted RF Power (dBm)	Antenna Gain (dBi)	EIRP (dBm)	EIRP Limit (dBm)	Margin (dB)	Result
2506.0	100	0	21.9	-2.8	19.1	33.0	13.9	Complied
2506.0	50	25	21.9	-2.8	19.1	33.0	13.9	Complied
2506.0	1	0	22.4	-2.8	19.6	33.0	13.4	Complied
2506.0	1	99	22.8	-2.8	20.0	33.0	13.0	Complied

Results: 20 MHz Channel Bandwidth / Bottom Channel / 16QAM

Frequency (MHz)	Resource Block(s)	Resource Block Offset	Conducted RF Power (dBm)	Antenna Gain (dBi)	EIRP (dBm)	EIRP Limit (dBm)	Margin (dB)	Result
2506.0	100	0	20.8	-2.8	18.0	33.0	15.0	Complied
2506.0	50	25	21.1	-2.8	18.3	33.0	14.7	Complied
2506.0	1	0	21.4	-2.8	18.6	33.0	14.4	Complied
2506.0	1	99	21.4	-2.8	18.6	33.0	14.4	Complied

Transmitter Output Power (EIRP) (continued)**Results: 20 MHz Channel Bandwidth / Middle Channel / QPSK**

Frequency (MHz)	Resource Block(s)	Resource Block Offset	Conducted RF Power (dBm)	Antenna Gain (dBi)	EIRP (dBm)	EIRP Limit (dBm)	Margin (dB)	Result
2593.0	100	0	21.8	-2.8	19.0	33.0	14.0	Complied
2593.0	50	25	21.9	-2.8	19.1	33.0	13.9	Complied
2593.0	1	0	23.1	-2.8	20.3	33.0	12.7	Complied
2593.0	1	99	22.6	-2.8	19.8	33.0	13.2	Complied

Results: 20 MHz Channel Bandwidth / Middle Channel / 16QAM

Frequency (MHz)	Resource Block(s)	Resource Block Offset	Conducted RF Power (dBm)	Antenna Gain (dBi)	EIRP (dBm)	EIRP Limit (dBm)	Margin (dB)	Result
2593.0	100	0	20.8	-2.8	18.0	33.0	15.0	Complied
2593.0	50	25	20.8	-2.8	18.0	33.0	15.0	Complied
2593.0	1	0	22.5	-2.8	19.7	33.0	13.3	Complied
2593.0	1	99	22.1	-2.8	19.3	33.0	13.7	Complied

Results: 20 MHz Channel Bandwidth / Top Channel / QPSK

Frequency (MHz)	Resource Block(s)	Resource Block Offset	Conducted RF Power (dBm)	Antenna Gain (dBi)	EIRP (dBm)	EIRP Limit (dBm)	Margin (dB)	Result
2680.0	100	0	22.2	-2.8	19.4	33.0	13.6	Complied
2680.0	50	25	22.3	-2.8	19.5	33.0	13.5	Complied
2680.0	1	0	22.8	-2.8	20.0	33.0	13.0	Complied
2680.0	1	99	21.8	-2.8	19.0	33.0	14.0	Complied

Results: 20 MHz Channel Bandwidth / Top Channel / 16QAM

Frequency (MHz)	Resource Block(s)	Resource Block Offset	Conducted RF Power (dBm)	Antenna Gain (dBi)	EIRP (dBm)	EIRP Limit (dBm)	Margin (dB)	Result
2680.0	100	0	21.3	-2.8	18.5	33.0	14.5	Complied
2680.0	50	25	21.2	-2.8	18.4	33.0	14.6	Complied
2680.0	1	0	22.2	-2.8	19.4	33.0	13.6	Complied
2680.0	1	99	21.2	-2.8	18.4	33.0	14.6	Complied

Transmitter Output Power (EIRP) (continued)**Test Equipment Used:**

Asset No.	Instrument	Manufacturer	Type No.	Serial No.	Date Calibration Due	Cal. Interval (Months)
M2002	Thermohygrometer	Testo	608-H1	45041825	02 Apr 2017	12
M1869	Wideband Radio Comms Tester	Rohde & Schwarz	CMW500	145923	05 Apr 2017	12
A2845	Attenuator	Radiall	R411.806.121	24325927	Calibrated before use	-
A2844	Attenuator	Radiall	R411.803.121	23404066	Calibrated before use	-
A2504	Directional Coupler	AtlanTecRF	CDC-003060-10	13122501839	Calibrated before use	-
S0577	Power Supply	TTi	CPX400S	436670	Calibrated before use	-
M1269	Multimeter	Fluke	179	90250210	26 May 2016	12
M1835	Signal Analyser	Rohde & Schwarz	FSV30	103050	26 Feb 2017	12

5.2.2. Transmitter Peak-To-Average Ratio (PAR)**Test Summary:**

Test Engineer:	Keith Tucker	Test Dates:	14 May 2016
Test Sample IMEI:	357232070003163		

FCC Reference:	Part 27.50(d)(5)
Test Method Used:	KDB 971168 Section 5.7.2

Environmental Conditions:

Temperature (°C):	24
Relative Humidity (%):	46

Note(s):

1. The peak (P_{Pk}) and average (P_{Avg}) power were measured using the internal power measurement function of a calibrated Rohde and Schwarz CMW 500 Wideband Radio Communication Tester in accordance with current Rohde and Schwarz application notes.
2. The PAPR was determined using the following calculation:

$$PAPR (dB) = P_{Pk} (dBm) - P_{Avg} (dBm).$$

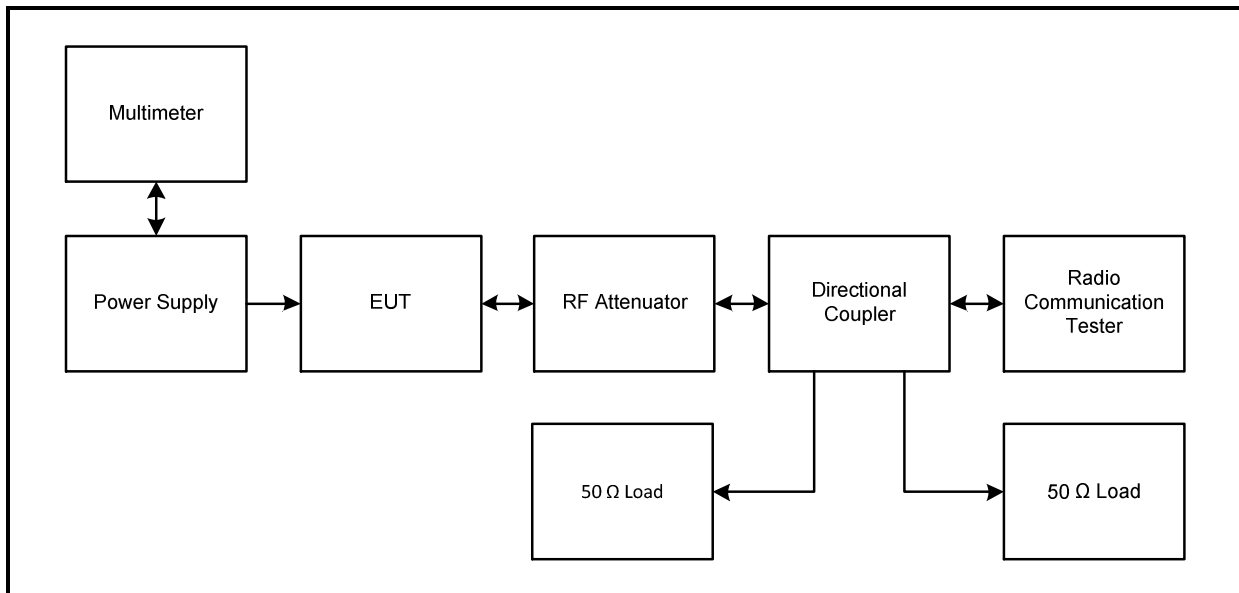
Test setup:

Transmitter Peak-To-Average Ratio (PAR) (continued)**Results: 5 MHz Channel Bandwidth / Bottom Channel / QPSK**

Frequency (MHz)	Resource Block(s)	Resource Block Offset	P _{Pk} (dBm)	P _{Avg} (dBm)	PAR (dB)	Ratio Limit (dB)	Margin (dB)	Result
2498.5	25	0	27.3	21.9	5.4	13.0	7.6	Complied
2498.5	12	6	26.0	22.0	4.0	13.0	9.0	Complied
2498.5	1	0	24.3	21.8	2.5	13.0	10.5	Complied
2498.5	1	24	24.7	22.2	2.5	13.0	10.5	Complied

Results: 5 MHz Channel Bandwidth / Bottom Channel / 16QAM

Frequency (MHz)	Resource Block(s)	Resource Block Offset	P _{Pk} (dBm)	P _{Avg} (dBm)	PAR (dB)	Ratio Limit (dB)	Margin (dB)	Result
2498.5	25	0	27.2	21.0	6.2	13.0	6.8	Complied
2498.5	12	6	26.1	21.1	5.0	13.0	8.0	Complied
2498.5	1	0	24.4	21.2	3.2	13.0	9.8	Complied
2498.5	1	24	24.8	21.5	3.3	13.0	9.7	Complied

Results: 5 MHz Channel Bandwidth / Middle Channel / QPSK

Frequency (MHz)	Resource Block(s)	Resource Block Offset	P _{Pk} (dBm)	P _{Avg} (dBm)	PAR (dB)	Ratio Limit (dB)	Margin (dB)	Result
2593.0	25	0	27.6	21.7	5.9	13.0	7.1	Complied
2593.0	12	6	26.0	21.9	4.1	13.0	8.9	Complied
2593.0	1	0	25.3	22.8	2.5	13.0	10.5	Complied
2593.0	1	24	25.1	22.5	2.6	13.0	10.4	Complied

Results: 5 MHz Channel Bandwidth / Middle Channel / 16QAM

Frequency (MHz)	Resource Block(s)	Resource Block Offset	P _{Pk} (dBm)	P _{Avg} (dBm)	PAR (dB)	Ratio Limit (dB)	Margin (dB)	Result
2593.0	25	0	27.1	20.8	6.3	13.0	6.7	Complied
2593.0	12	6	26.1	21.0	5.1	13.0	7.9	Complied
2593.0	1	0	25.3	22.1	3.2	13.0	9.8	Complied
2593.0	1	24	25.3	22.1	3.2	13.0	9.8	Complied

Transmitter Peak-To-Average Ratio (PAR) (continued)**Results: 5 MHz Channel Bandwidth / Top Channel / QPSK**

Frequency (MHz)	Resource Block(s)	Resource Block Offset	P _{Pk} (dBm)	P _{Avg} (dBm)	PAR (dB)	Ratio Limit (dB)	Margin (dB)	Result
2687.5	25	0	27.4	22.4	5.0	13.0	8.0	Complied
2687.5	12	6	26.5	22.4	4.1	13.0	8.9	Complied
2687.5	1	0	24.8	22.2	2.6	13.0	10.4	Complied
2687.5	1	24	24.5	21.8	2.7	13.0	10.3	Complied

Results: 5 MHz Channel Bandwidth / Top Channel / 16QAM

Frequency (MHz)	Resource Block(s)	Resource Block Offset	P _{Pk} (dBm)	P _{Avg} (dBm)	PAR (dB)	Ratio Limit (dB)	Margin (dB)	Result
2687.5	25	0	27.6	21.3	6.3	13.0	6.7	Complied
2687.5	12	6	26.4	21.3	5.1	13.0	7.9	Complied
2687.5	1	0	24.8	21.3	3.5	13.0	9.5	Complied
2687.5	1	24	24.5	21.0	3.5	13.0	9.5	Complied

Results: 10 MHz Channel Bandwidth / Bottom Channel / QPSK

Frequency (MHz)	Resource Block(s)	Resource Block Offset	P _{Pk} (dBm)	P _{Avg} (dBm)	PAR (dB)	Ratio Limit (dB)	Margin (dB)	Result
2501.0	50	0	27.5	22.0	5.5	13.0	7.5	Complied
2501.0	25	12	26.2	22.0	4.2	13.0	8.8	Complied
2501.0	1	0	24.3	22.0	2.3	13.0	10.7	Complied
2501.0	1	49	24.9	22.5	2.4	13.0	10.6	Complied

Results: 10 MHz Channel Bandwidth / Bottom Channel / 16QAM

Frequency (MHz)	Resource Block(s)	Resource Block Offset	P _{Pk} (dBm)	P _{Avg} (dBm)	PAR (dB)	Ratio Limit (dB)	Margin (dB)	Result
2501.0	50	0	27.3	21.0	6.3	13.0	6.7	Complied
2501.0	25	12	26.4	21.1	5.3	13.0	7.7	Complied
2501.0	1	0	24.3	21.1	3.2	13.0	9.8	Complied
2501.0	1	49	25.0	21.9	3.1	13.0	9.9	Complied

Transmitter Peak-To-Average Ratio (PAR) (continued)**Results: 10 MHz Channel Bandwidth / Middle Channel / QPSK**

Frequency (MHz)	Resource Block(s)	Resource Block Offset	P _{Pk} (dBm)	P _{Avg} (dBm)	PAR (dB)	Ratio Limit (dB)	Margin (dB)	Result
2593.0	50	0	27.6	21.7	5.9	13.0	7.1	Complied
2593.0	25	12	26.2	21.8	4.4	13.0	8.6	Complied
2593.0	1	0	25.3	22.5	2.8	13.0	10.2	Complied
2593.0	1	49	25.2	22.3	2.9	13.0	10.1	Complied

Results: 10 MHz Channel Bandwidth / Middle Channel / 16QAM

Frequency (MHz)	Resource Block(s)	Resource Block Offset	P _{Pk} (dBm)	P _{Avg} (dBm)	PAR (dB)	Ratio Limit (dB)	Margin (dB)	Result
2593.0	50	0	27.2	20.8	6.4	13.0	6.6	Complied
2593.0	25	12	26.4	20.8	5.6	13.0	7.4	Complied
2593.0	1	0	25.5	22.4	3.1	13.0	9.9	Complied
2593.0	1	49	25.4	22.3	3.1	13.0	9.9	Complied

Results: 10 MHz Channel Bandwidth / Top Channel / QPSK

Frequency (MHz)	Resource Block(s)	Resource Block Offset	P _{Pk} (dBm)	P _{Avg} (dBm)	PAR (dB)	Ratio Limit (dB)	Margin (dB)	Result
2685.0	50	0	27.5	22.2	5.3	13.0	7.7	Complied
2685.0	25	12	26.6	22.2	4.4	13.0	8.6	Complied
2685.0	1	0	25.1	22.4	2.7	13.0	10.3	Complied
2685.0	1	49	24.6	21.7	2.9	13.0	10.1	Complied

Results: 10 MHz Channel Bandwidth / Top Channel / 16QAM

Frequency (MHz)	Resource Block(s)	Resource Block Offset	P _{Pk} (dBm)	P _{Avg} (dBm)	PAR (dB)	Ratio Limit (dB)	Margin (dB)	Result
2685.0	50	0	27.3	21.2	6.1	13.0	6.9	Complied
2685.0	25	12	26.5	21.3	5.2	13.0	7.8	Complied
2685.0	1	0	25.2	21.5	3.7	13.0	9.3	Complied
2685.0	1	49	24.6	20.9	3.7	13.0	9.3	Complied

Transmitter Peak-To-Average Ratio (PAR) (continued)**Results: 15 MHz Channel Bandwidth / Bottom Channel / QPSK**

Frequency (MHz)	Resource Block(s)	Resource Block Offset	P _{Pk} (dBm)	P _{Avg} (dBm)	PAR (dB)	Ratio Limit (dB)	Margin (dB)	Result
2503.5	75	0	27.6	21.8	5.8	13.0	7.2	Complied
2503.5	36	18	26.6	22.0	4.6	13.0	8.4	Complied
2503.5	1	0	25.3	22.3	3.0	13.0	10.0	Complied
2503.5	1	74	25.3	22.4	2.9	13.0	10.1	Complied

Results: 15 MHz Channel Bandwidth / Bottom Channel / 16QAM

Frequency (MHz)	Resource Block(s)	Resource Block Offset	P _{Pk} (dBm)	P _{Avg} (dBm)	PAR (dB)	Ratio Limit (dB)	Margin (dB)	Result
2503.5	75	0	27.5	21.0	6.5	13.0	6.5	Complied
2503.5	36	18	26.4	20.9	5.5	13.0	7.5	Complied
2503.5	1	0	25.2	21.4	3.8	13.0	9.2	Complied
2503.5	1	74	25.4	21.6	3.8	13.0	9.2	Complied

Results: 15 MHz Channel Bandwidth / Middle Channel / QPSK

Frequency (MHz)	Resource Block(s)	Resource Block Offset	P _{Pk} (dBm)	P _{Avg} (dBm)	PAR (dB)	Ratio Limit (dB)	Margin (dB)	Result
2593.0	75	0	27.6	21.7	5.9	13.0	7.1	Complied
2593.0	36	18	26.3	21.8	4.5	13.0	8.5	Complied
2593.0	1	0	26.0	23.2	2.8	13.0	10.2	Complied
2593.0	1	74	25.6	22.7	2.9	13.0	10.1	Complied

Results: 15 MHz Channel Bandwidth / Middle Channel / 16QAM

Frequency (MHz)	Resource Block(s)	Resource Block Offset	P _{Pk} (dBm)	P _{Avg} (dBm)	PAR (dB)	Ratio Limit (dB)	Margin (dB)	Result
2593.0	75	0	27.4	20.8	6.6	13.0	6.4	Complied
2593.0	36	18	26.5	20.9	5.6	13.0	7.4	Complied
2593.0	1	0	25.8	22.3	3.5	13.0	9.5	Complied
2593.0	1	74	25.3	21.7	3.6	13.0	9.4	Complied

Transmitter Peak-To-Average Ratio (PAR) (continued)**Results: 15 MHz Channel Bandwidth / Top Channel / QPSK**

Frequency (MHz)	Resource Block(s)	Resource Block Offset	P _{Pk} (dBm)	P _{Avg} (dBm)	PAR (dB)	Ratio Limit (dB)	Margin (dB)	Result
2682.5	75	0	27.8	22.2	5.6	13.0	7.4	Complied
2682.5	36	18	26.8	22.3	4.5	13.0	8.5	Complied
2682.5	1	0	25.7	22.7	3.0	13.0	10.0	Complied
2682.5	1	74	25.1	21.9	3.2	13.0	9.8	Complied

Results: 15 MHz Channel Bandwidth / Top Channel / 16QAM

Frequency (MHz)	Resource Block(s)	Resource Block Offset	P _{Pk} (dBm)	P _{Avg} (dBm)	PAR (dB)	Ratio Limit (dB)	Margin (dB)	Result
2682.5	75	0	27.7	21.2	6.5	13.0	6.5	Complied
2682.5	36	18	26.7	21.3	5.4	13.0	7.6	Complied
2682.5	1	0	25.7	22.3	3.4	13.0	9.6	Complied
2682.5	1	74	25.2	21.6	3.6	13.0	9.4	Complied

Results: 20 MHz Channel Bandwidth / Bottom Channel / QPSK

Frequency (MHz)	Resource Block(s)	Resource Block Offset	P _{Pk} (dBm)	P _{Avg} (dBm)	PAR (dB)	Ratio Limit (dB)	Margin (dB)	Result
2506.0	100	0	27.7	21.9	5.8	13.0	7.2	Complied
2506.0	50	25	26.5	21.9	4.6	13.0	8.4	Complied
2506.0	1	0	25.5	22.4	3.1	13.0	9.9	Complied
2506.0	1	99	25.8	22.8	3.0	13.0	10.0	Complied

Results: 20 MHz Channel Bandwidth / Bottom Channel / 16QAM

Frequency (MHz)	Resource Block(s)	Resource Block Offset	P _{Pk} (dBm)	P _{Avg} (dBm)	PAR (dB)	Ratio Limit (dB)	Margin (dB)	Result
2506.0	100	0	27.7	20.8	6.9	13.0	6.1	Complied
2506.0	50	25	26.6	21.1	5.5	13.0	7.5	Complied
2506.0	1	0	25.3	21.4	3.9	13.0	9.1	Complied
2506.0	1	99	25.4	21.4	4.0	13.0	9.0	Complied

Transmitter Peak-To-Average Ratio (PAR) (continued)**Results: 20 MHz Channel Bandwidth / Middle Channel / QPSK**

Frequency (MHz)	Resource Block(s)	Resource Block Offset	P _{Pk} (dBm)	P _{Avg} (dBm)	PAR (dB)	Ratio Limit (dB)	Margin (dB)	Result
2593.0	100	0	27.7	21.8	5.9	13.0	7.1	Complied
2593.0	50	25	26.5	21.9	4.6	13.0	8.4	Complied
2593.0	1	0	25.9	23.1	2.8	13.0	10.2	Complied
2593.0	1	99	25.7	22.6	3.1	13.0	9.9	Complied

Results: 20 MHz Channel Bandwidth / Middle Channel / 16QAM

Frequency (MHz)	Resource Block(s)	Resource Block Offset	P _{Pk} (dBm)	P _{Avg} (dBm)	PAR (dB)	Ratio Limit (dB)	Margin (dB)	Result
2593.0	100	0	27.3	20.8	6.5	13.0	6.5	Complied
2593.0	50	25	26.3	20.8	5.5	13.0	7.5	Complied
2593.0	1	0	26.1	22.5	3.6	13.0	9.4	Complied
2593.0	1	99	25.6	22.1	3.5	13.0	9.5	Complied

Results: 20 MHz Channel Bandwidth / Top Channel / QPSK

Frequency (MHz)	Resource Block(s)	Resource Block Offset	P _{Pk} (dBm)	P _{Avg} (dBm)	PAR (dB)	Ratio Limit (dB)	Margin (dB)	Result
2680.0	100	0	27.8	22.2	5.6	13.0	7.4	Complied
2680.0	50	25	26.9	22.3	4.6	13.0	8.4	Complied
2680.0	1	0	26.1	22.8	3.3	13.0	9.7	Complied
2680.0	1	99	25.2	21.8	3.4	13.0	9.6	Complied

Results: 20 MHz Channel Bandwidth / Top Channel / 16QAM

Frequency (MHz)	Resource Block(s)	Resource Block Offset	P _{Pk} (dBm)	P _{Avg} (dBm)	PAR (dB)	Ratio Limit (dB)	Margin (dB)	Result
2680.0	100	0	27.7	21.3	6.4	13.0	6.6	Complied
2680.0	50	25	26.8	21.2	5.6	13.0	7.4	Complied
2680.0	1	0	25.9	22.2	3.7	13.0	9.3	Complied
2680.0	1	99	25.2	21.2	4.0	13.0	9.0	Complied

Transmitter Peak-To-Average Ratio (PAR) (continued)**Test Equipment Used:**

Asset No.	Instrument	Manufacturer	Type No.	Serial No.	Date Calibration Due	Cal. Interval (Months)
M2002	Thermohygrometer	Testo	608-H1	45041825	02 Apr 2017	12
M1869	Wideband Radio Comms Tester	Rohde & Schwarz	CMW500	145923	05 Apr 2017	12
A2845	Attenuator	Radiall	R411.806.121	24325927	Calibrated before use	-
A2844	Attenuator	Radiall	R411.803.121	23404066	Calibrated before use	-
A2504	Directional Coupler	AtlanTecRF	CDC-003060-10	13122501839	Calibrated before use	-
S0577	Power Supply	TTi	CPX400S	436670	Calibrated before use	-
M1269	Multimeter	Fluke	179	90250210	26 May 2016	12
M1835	Signal Analyser	Rohde & Schwarz	FSV30	103050	26 Feb 2017	12

5.2.3. Transmitter Occupied Bandwidth

Test Summary:

Test Engineer:	Keith Tucker	Test Date:	14 May 2016
Test Sample IMEI:	357232070003163		

FCC Reference:	Part 2.1049
Test Method Used:	KDB 971168 Section 4.2

Environmental Conditions:

Temperature (°C):	24
Relative Humidity (%):	46

Note(s):

1. Occupied bandwidth (99% bandwidth) was measured using a test receiver occupied bandwidth function.
2. Measurements were performed with the EUT transmitting with QPSK and 16QAM modulation schemes, with resource blocks settings as detailed in section 4.3 of this report.
3. The RF port of the EUT was connected to the signal analyser via RF cables, directional coupler and suitable attenuation.

Test setup:

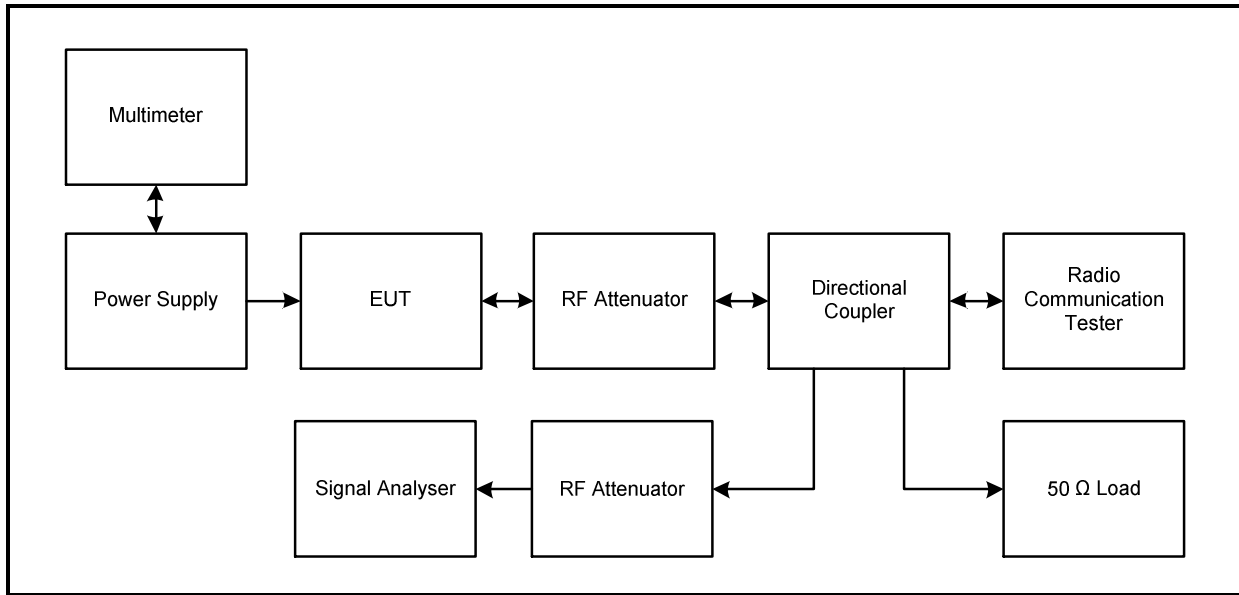

Transmitter Occupied Bandwidth (continued)

Results: 5 MHz Channel Bandwidth / QPSK

Channel	Resource Block(s)	Resource Block Offset	Resolution Bandwidth (kHz)	Video Bandwidth (kHz)	Occupied Bandwidth (MHz)
Bottom	25	0	100	300	4.510
Middle	25	0	100	300	4.526
Top	25	0	100	300	4.542

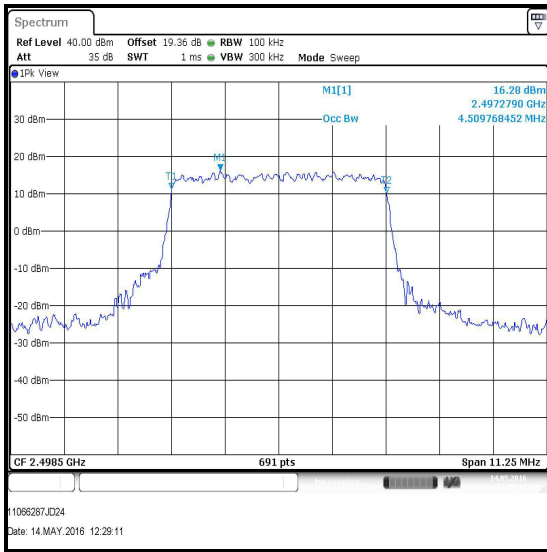

Bottom Channel / QPSK



Middle Channel / QPSK

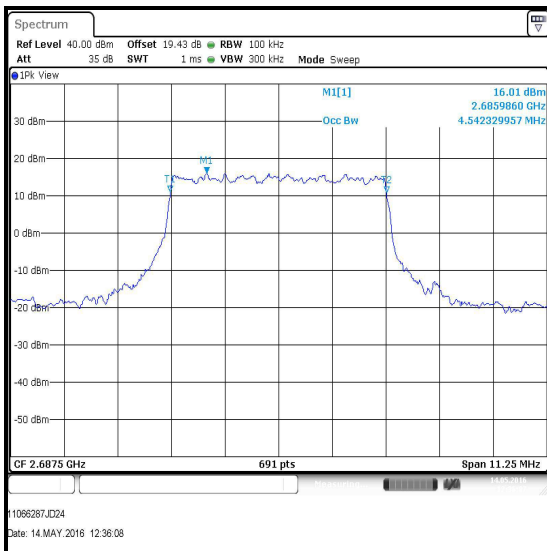

Top Channel / QPSK

Transmitter Occupied Bandwidth (continued)

Results: 5 MHz Channel Bandwidth / 16QAM

Channel	Resource Block(s)	Resource Block Offset	Resolution Bandwidth (kHz)	Video Bandwidth (kHz)	Occupied Bandwidth (MHz)
Bottom	25	0	100	300	4.493
Middle	25	0	100	300	4.493
Top	25	0	100	300	4.510

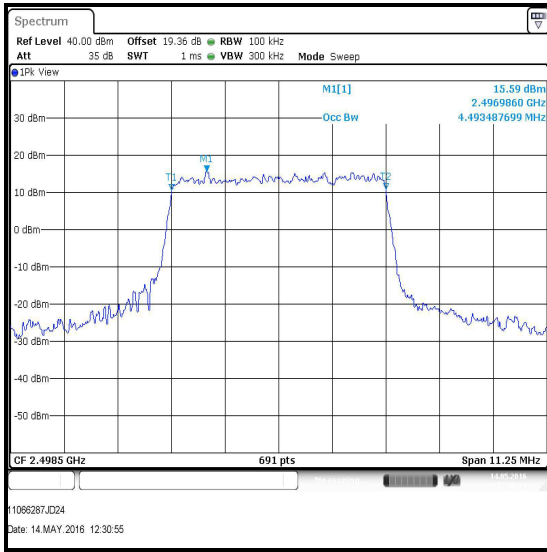

Bottom Channel / 16QAM

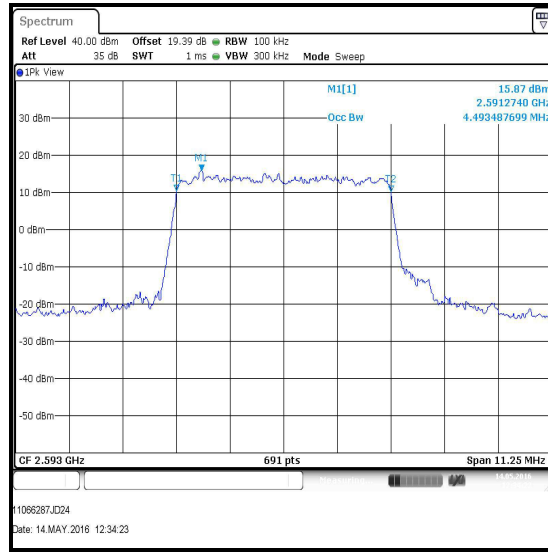

Middle Channel / 16QAM

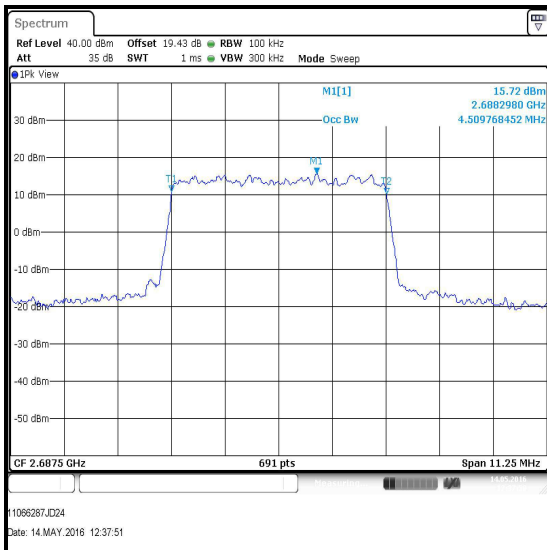

Top Channel / 16QAM

Transmitter Occupied Bandwidth (continued)

Results: 10 MHz Channel Bandwidth / QPSK

Channel	Resource Block(s)	Resource Block Offset	Resolution Bandwidth (kHz)	Video Bandwidth (kHz)	Occupied Bandwidth (MHz)
Bottom	50	0	200	1000	9.052
Middle	50	0	200	1000	8.987
Top	50	0	200	1000	9.020

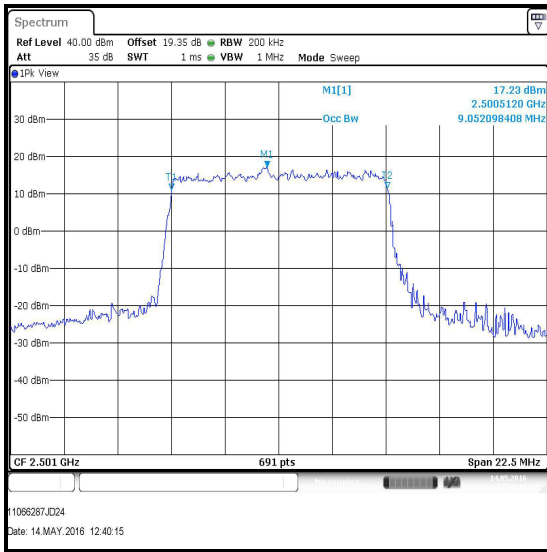

Bottom Channel / QPSK

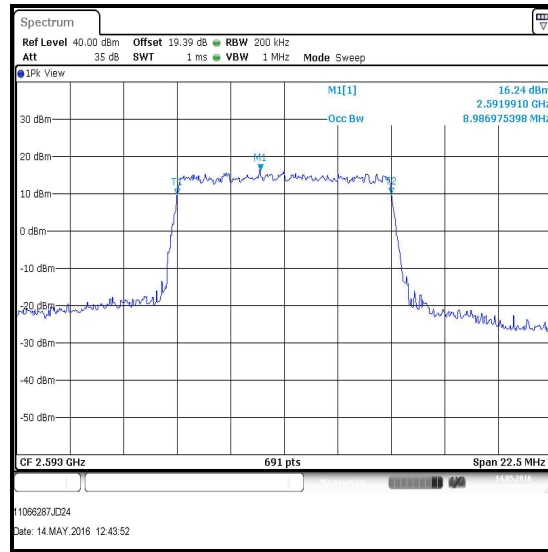

Middle Channel / QPSK

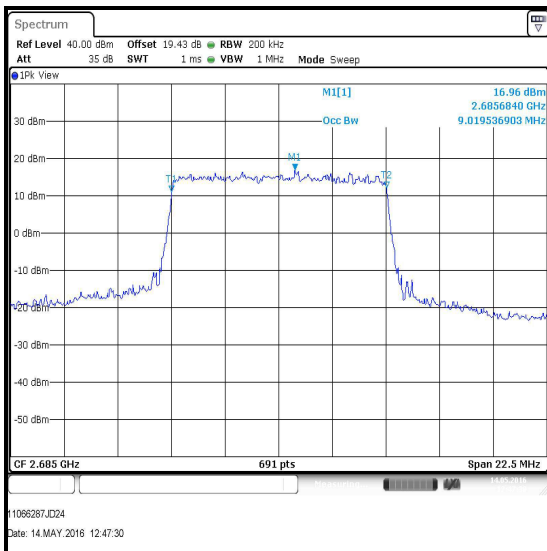

Top Channel / QPSK

Transmitter Occupied Bandwidth (continued)

Results: 10 MHz Channel Bandwidth / 16QAM

Channel	Resource Block(s)	Resource Block Offset	Resolution Bandwidth (kHz)	Video Bandwidth (kHz)	Occupied Bandwidth (MHz)
Bottom	50	0	200	1000	8.987
Middle	50	0	200	1000	8.987
Top	50	0	200	1000	8.987

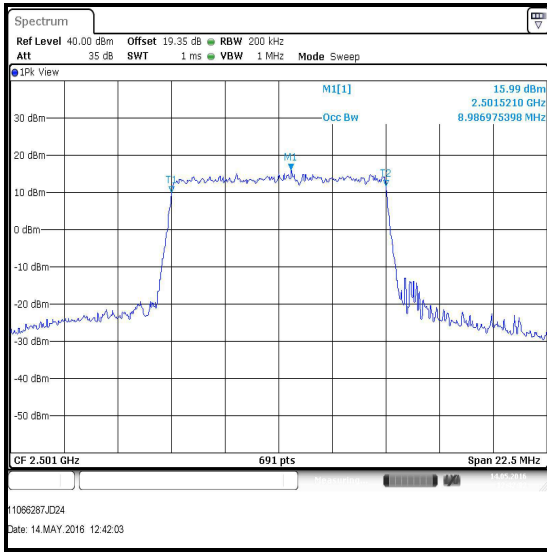

Bottom Channel / 16QAM

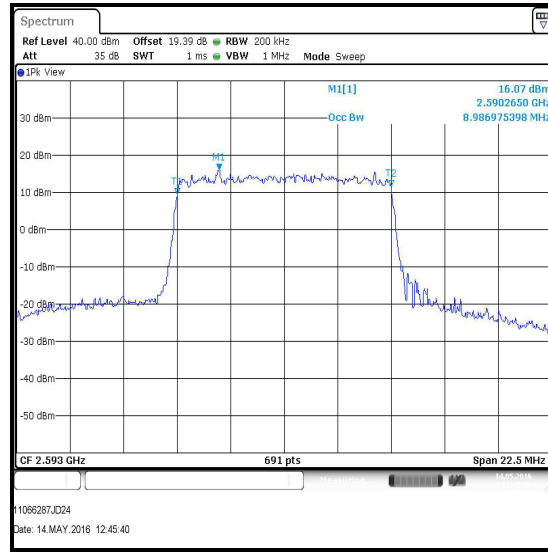

Middle Channel / 16QAM

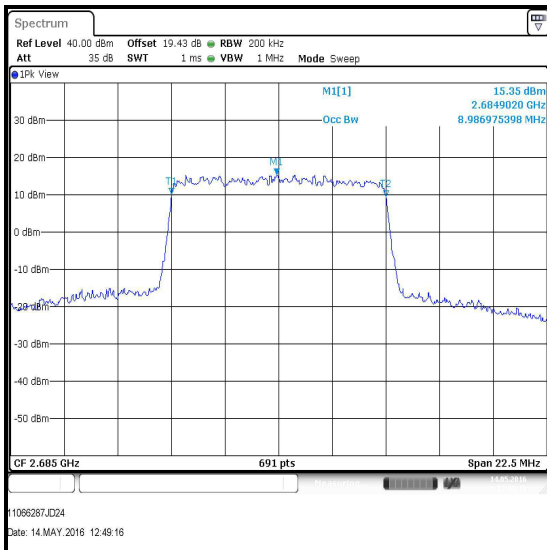

Top Channel / 16QAM

Transmitter Occupied Bandwidth (continued)

Results: 15 MHz Channel Bandwidth / QPSK

Channel	Resource Block(s)	Resource Block Offset	Resolution Bandwidth (kHz)	Video Bandwidth (kHz)	Occupied Bandwidth (MHz)
Bottom	75	0	300	1000	13.480
Middle	75	0	300	1000	13.529
Top	75	0	300	1000	13.480

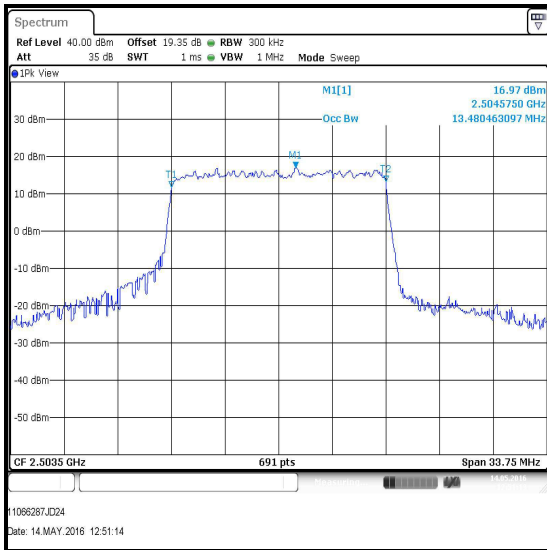

Bottom Channel / QPSK

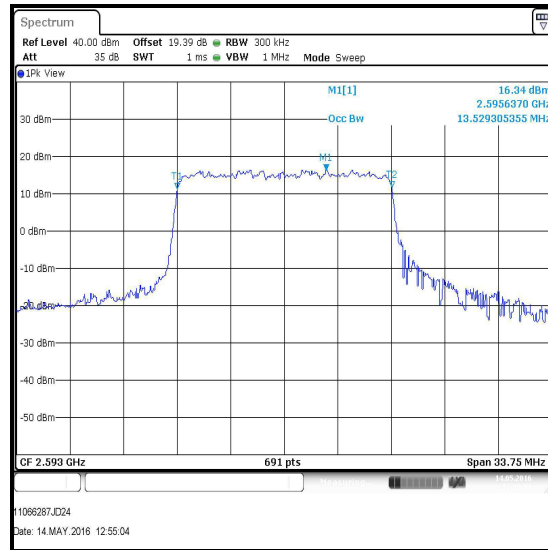

Middle Channel / QPSK

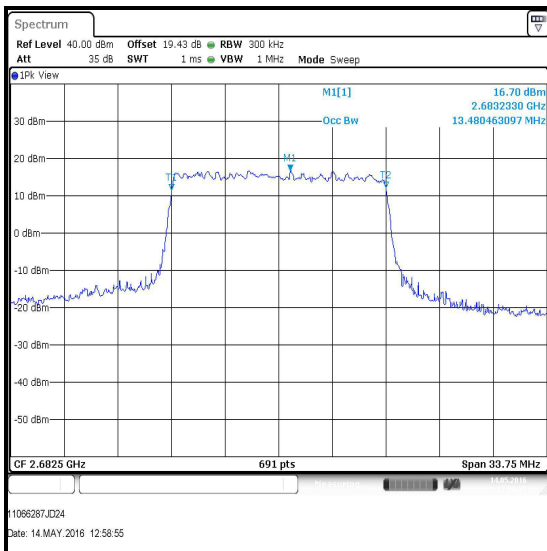

Top Channel / QPSK

Transmitter Occupied Bandwidth (continued)

Results: 15 MHz Channel Bandwidth / 16QAM

Channel	Resource Block(s)	Resource Block Offset	Resolution Bandwidth (kHz)	Video Bandwidth (kHz)	Occupied Bandwidth (MHz)
Bottom	75	0	300	1000	13.480
Middle	75	0	300	1000	13.529
Top	75	0	300	1000	13.578

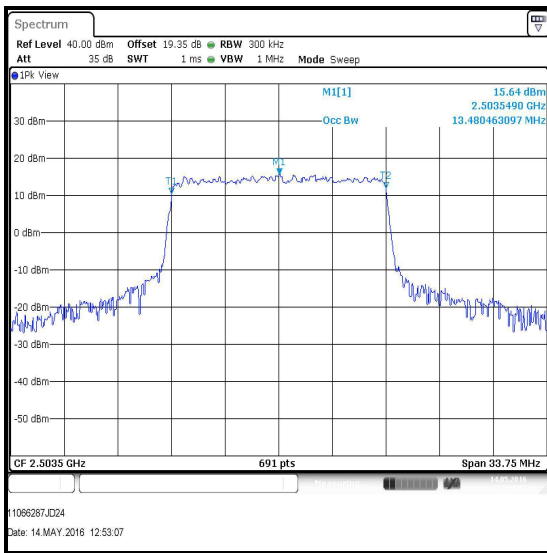

Bottom Channel / 16QAM

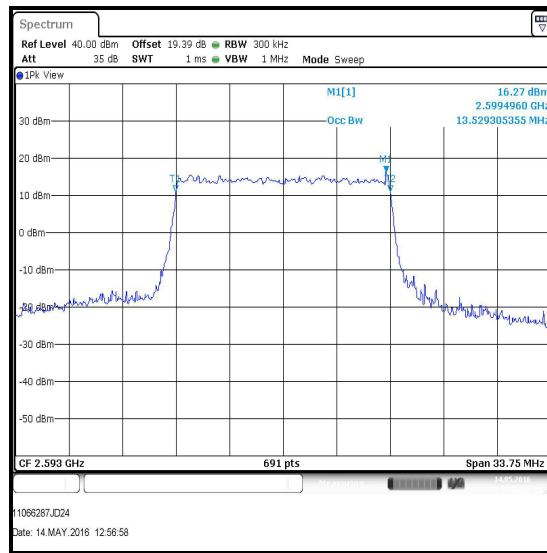

Middle Channel / 16QAM

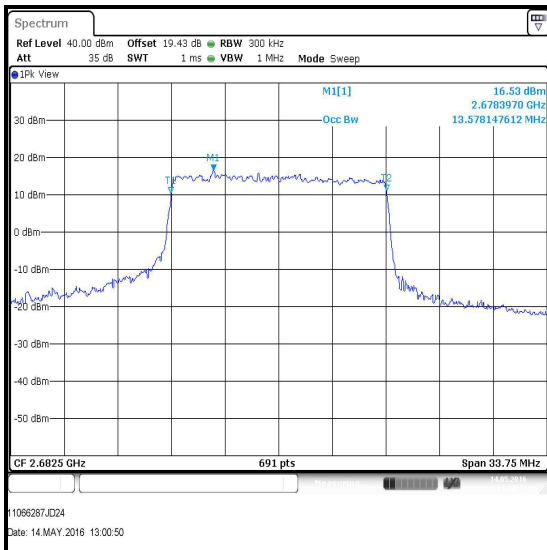

Top Channel / 16QAM

Transmitter Occupied Bandwidth (continued)

Results: 20 MHz Channel Bandwidth / QPSK

Channel	Resource Block(s)	Resource Block Offset	Resolution Bandwidth (kHz)	Video Bandwidth (kHz)	Occupied Bandwidth (MHz)
Bottom	100	0	500	2000	18.104
Middle	100	0	500	2000	18.039
Top	100	0	500	2000	18.039

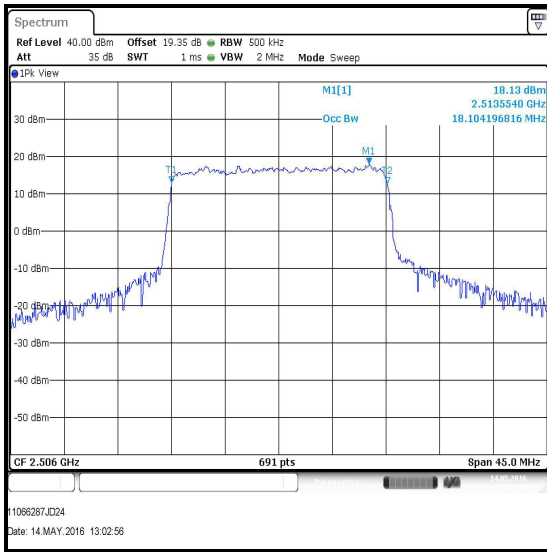

Bottom Channel / QPSK

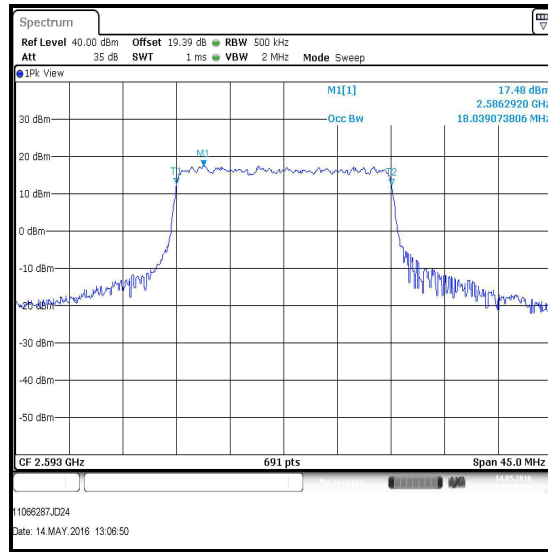

Middle Channel / QPSK

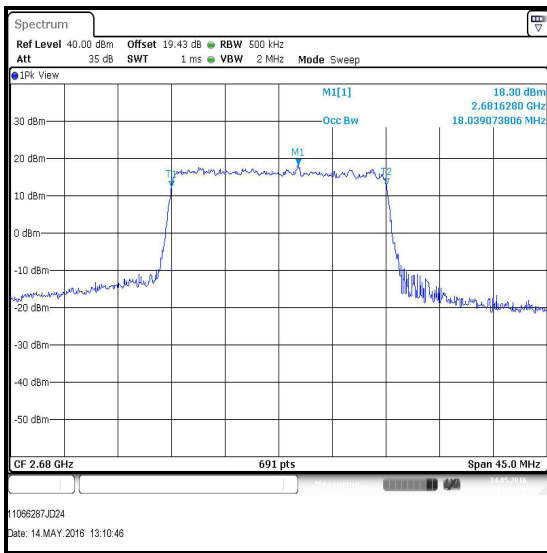

Top Channel / QPSK

Transmitter Occupied Bandwidth (continued)

Results: 20 MHz Channel Bandwidth / 16QAM

Channel	Resource Block(s)	Resource Block Offset	Resolution Bandwidth (kHz)	Video Bandwidth (kHz)	Occupied Bandwidth (MHz)
Bottom	100	0	500	2000	17.974
Middle	100	0	500	2000	18.039
Top	100	0	500	2000	18.104

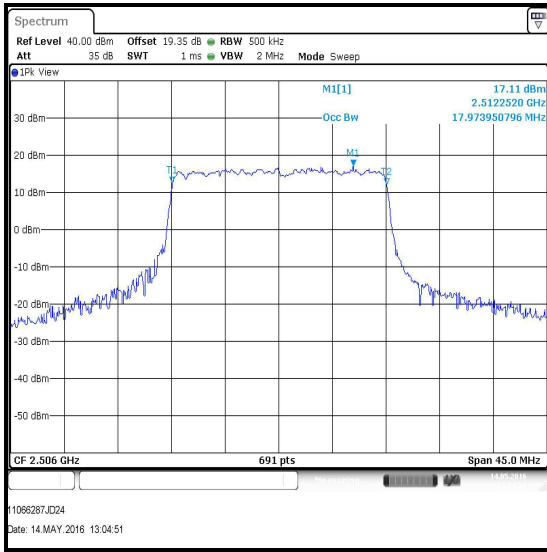

Bottom Channel / 16QAM

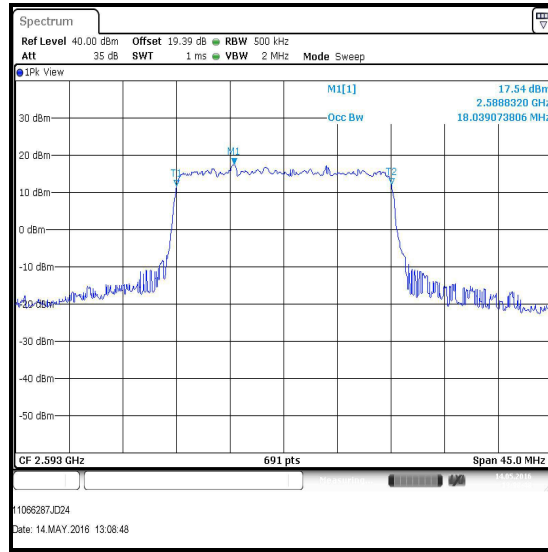

Middle Channel / 16QAM

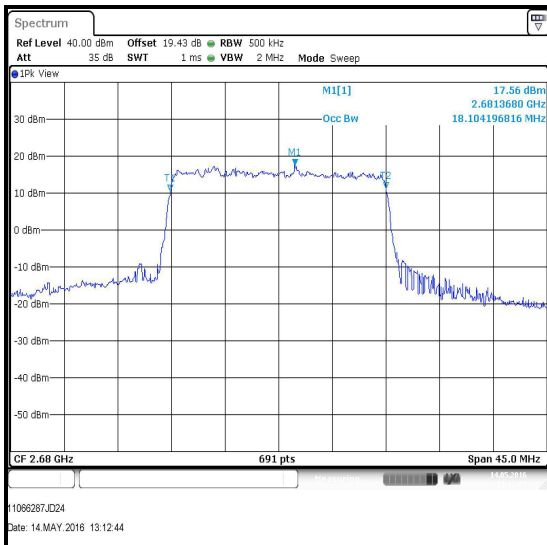

Top Channel / 16QAM

Transmitter Occupied Bandwidth (continued)**Test Equipment Used:**

Asset No.	Instrument	Manufacturer	Type No.	Serial No.	Date Calibration Due	Cal. Interval (Months)
M2002	Thermohygrometer	Testo	608-H1	45041825	02 Apr 2017	12
M1869	Wideband Radio Comms Tester	Rohde & Schwarz	CMW500	145923	05 Apr 2017	12
A2845	Attenuator	Radiall	R411.806.121	24325927	Calibrated before use	-
A2844	Attenuator	Radiall	R411.803.121	23404066	Calibrated before use	-
A2504	Directional Coupler	AtlanTecRF	CDC-003060-10	13122501839	Calibrated before use	-
S0577	Power Supply	TTi	CPX400S	436670	Calibrated before use	-
M1269	Multimeter	Fluke	179	90250210	26 May 2016	12
M1835	Signal Analyser	Rohde & Schwarz	FSV30	103050	26 Feb 2017	12

5.2.4. Transmitter Frequency Stability (Temperature Variation)

Test Summary:

Test Engineer:	Stefan Ho	Test Dates:	27 May 2016 & 31 May 2016
Test Sample IMEI:	357232070003163		

FCC Reference:	Parts 2.1055 & 27.54
Test Method Used:	KDB 971168 Section 9.0 referencing ANSI TIA-603-D-2010 Section 2.2.2 and FCC Part 2.1055

Environmental Conditions:

Temperature (°C):	23 to 24
Relative Humidity (%):	40 to 41

Note(s):

1. Flying leads were connected internally to the EUT in place of the battery. These leads extended and connected to a bench power supply at the nominal voltage of 3.9 V
2. Frequency error was measured using a calibrated Rohde and Schwarz CMW 500 Universal Radio Communications Tester in accordance with current Rohde and Schwarz application notes. The EUT was connected by suitable RF cables to the CMW 500. A bi-directional communications link was established between the EUT and CMW 500. The frequency meter value was recorded.
3. Temperature was monitored throughout the test with a calibrated digital thermometer.

Test setup:

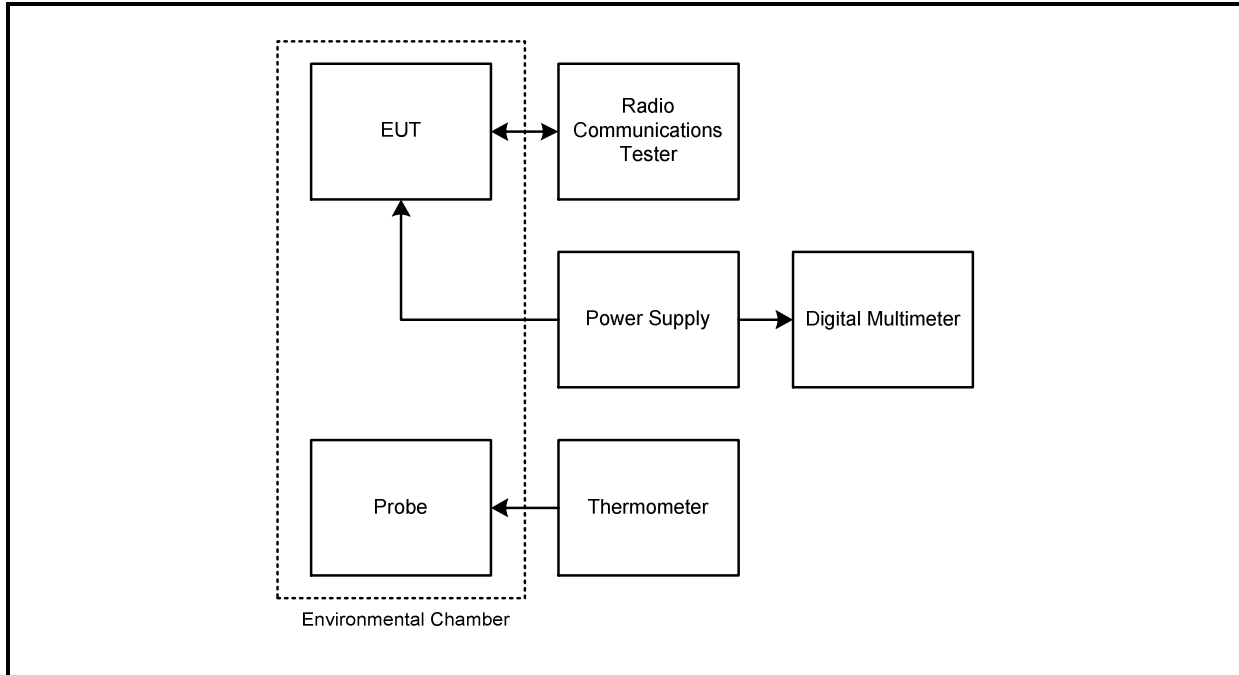

Transmitter Frequency Stability (Temperature Variation) (continued)**Results: Bottom Channel (2498.5 MHz)**

Temperature (°C)	Frequency Error (Hz)	Measured Frequency (MHz)	Lower Band Edge Limit (MHz)	Margin (MHz)	Result
-30	12	2498.500012	2496	2.500012	Complied
-20	11	2498.500011	2496	2.500011	Complied
-10	15	2498.500015	2496	2.500015	Complied
0	16	2498.500016	2496	2.500016	Complied
10	14	2498.500014	2496	2.500014	Complied
20	15	2498.500015	2496	2.500015	Complied
30	15	2498.500015	2496	2.500015	Complied
40	15	2498.500015	2496	2.500015	Complied
50	14	2498.500014	2496	2.500014	Complied

Results: Top Channel (2687.5 MHz)

Temperature (°C)	Frequency Error (Hz)	Measured Frequency (MHz)	Upper Band Edge Limit (MHz)	Margin (MHz)	Result
-30	47	2687.500047	2690	2.499953	Complied
-20	13	2687.500013	2690	2.499987	Complied
-10	13	2687.500013	2690	2.499987	Complied
0	14	2687.500014	2690	2.499986	Complied
10	14	2687.500014	2690	2.499986	Complied
20	16	2687.500016	2690	2.499984	Complied
30	11	2687.499989	2690	2.500011	Complied
40	16	2687.500016	2690	2.499984	Complied
50	12	2687.499988	2690	2.500012	Complied

Test Equipment Used:

Asset No.	Instrument	Manufacturer	Type No.	Serial No.	Date Calibration Due	Cal. Interval (Months)
M2002	Thermohygrometer	Testo	608-H1	45041825	02 Apr 2017	12
M1815	Environmental Chamber	Votsch/Heraeus	VT4002	521/83083	Calibrated before use	-
M1642	Thermometer	Fluke	52II	18890119	25 Apr 2017	12
S0577	DC power supply	TTI	CPX-400S	436670	Calibrated before use	-
M1869	Wideband Radio Comms Tester	Rohde & Schwarz	CMW 500	145923	05 Apr 2017	12
M1269	Multimeter	Fluke	179	90250210	13 May 2017	12

5.2.5. Transmitter Frequency Stability (Voltage Variation)**Test Summary:**

Test Engineer:	Stefan Ho	Test Dates:	27 May 2016 & 31 May 2016
Test Sample IMEI:	357232070003163		

FCC Reference:	Parts 2.1055 & 27.54
Test Method Used:	KDB 971168 Section 9.0 referencing ANSI TIA-603-D-2010 Section 2.2.2 and FCC Part 2.1055

Environmental Conditions:

Temperature (°C):	23 to 24
Relative Humidity (%):	40 to 41

Note(s):

1. Flying leads were connected internally to the EUT in place of the battery. These leads extended and connected to a bench power supply.
2. Frequency error was measured using a calibrated Rohde and Schwarz CMW 500 Universal Radio Communications Tester in accordance with current Rohde and Schwarz application notes. The EUT was connected by suitable RF cables to the CMW 500. A bi-directional communications link was established between the EUT and CMW 500. The frequency meter value was recorded.
3. Voltage was monitored throughout the test with a calibrated digital voltmeter.

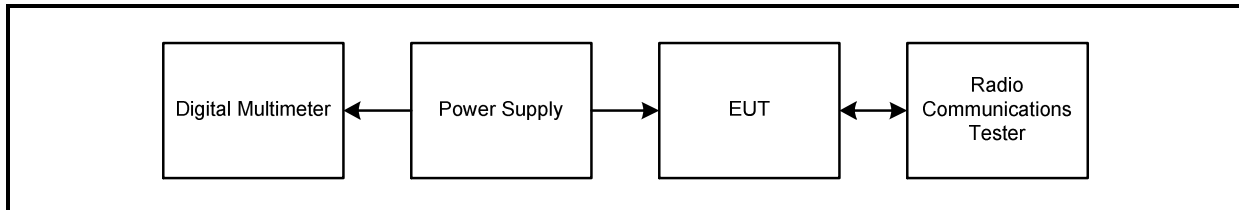
Test setup:

Transmitter Frequency Stability (Voltage Variation) (continued)**Results: Bottom Channel (2498.5 MHz)**

Supply Voltage (V)	Frequency Error (Hz)	Measured Frequency (MHz)	Lower Band Edge Limit (MHz)	Margin (MHz)	Result
3.5	11	2498.499989	2496	2.499989	Complied
4.4	11	2498.499989	2496	2.499989	Complied

Results: Top Channel (2687.5 MHz)

Supply Voltage (V)	Frequency Error (Hz)	Measured Frequency (MHz)	Upper Band Edge Limit (MHz)	Margin (MHz)	Result
3.5	10	2687.499990	2690	2.500010	Complied
4.4	11	2687.499989	2690	2.500011	Complied

Test Equipment Used:

Asset No.	Instrument	Manufacturer	Type No.	Serial No.	Date Calibration Due	Cal. Interval (Months)
M2002	Thermohygrometer	Testo	608-H1	45041825	02 Apr 2017	12
S0577	DC power supply	TTI	CPX-400S	436670	Calibrated before use	-
M1869	Wideband Radio Comms Tester	Rohde & Schwarz	CMW 500	145923	05 Apr 2017	12
M1269	Multimeter	Fluke	179	90250210	13 May 2017	12

6. Measurement Uncertainty

No measurement or test can ever be perfect and the imperfections give rise to error of measurement in the results. Consequently the result of a measurement is only an approximation to the value of the measurand (the specific quantity subject to measurement) and is only complete when accompanied by a statement of the uncertainty of the approximation.

The expression of uncertainty of a measurement result allows realistic comparison of results with reference values and limits given in specifications and standards.

The uncertainty of the result may need to be taken into account when interpreting the measurement results.

The reported expanded uncertainties below are based on a standard uncertainty multiplied by an appropriate coverage factor such that a confidence level of approximately 95% is maintained. For the purposes of this document "approximately" is interpreted as meaning "effectively" or "for most practical purposes".

Measurement Type	Range	Confidence Level (%)	Calculated Uncertainty
Conducted Output Power	2500 to 2570 MHz	95%	± 1.36 dB
Frequency Stability	2500 to 2570 MHz	95%	± 23 Hz
Occupied Bandwidth	2500 to 2570 MHz	95%	± 3.92 %

The methods used to calculate the above uncertainties are in line with those recommended within the various measurement specifications. Where measurement specifications do not include guidelines for the evaluation of measurement uncertainty the published guidance of the appropriate accreditation body is followed.

7. Report Revision History

Version Number	Revision Details		
	Page No(s)	Clause	Details
1.0	-	-	Initial Version

--- END OF REPORT ---