



TEST REPORT

Test Report No. : UL-RPT-RP11066287JD16A

Manufacturer : Flextronics International Sweden AB
Model No. : SR0020-W
FCC ID : 2AIP8I
Technology : LTE – Band 25
Test Standard(s) : FCC Parts 24.232(c), 24.232(d) & 24.235

1. This test report shall not be reproduced in full or partial, without the written approval of UL VS LTD.
2. The results in this report apply only to the sample(s) tested.
3. The sample tested is in compliance with the above standard(s).
4. The test results in this report are traceable to the national or international standards.
5. Version 1.0

Date of Issue: 25 June 2016

Checked by:

Sarah Williams
Engineer, Radio Laboratory

Company Signatory:

Steven White
Service Lead, Radio Laboratory,
UL VS LTD



This laboratory is accredited by UKAS.
The tests reported herein have been
performed in accordance with its terms
of accreditation.

UL VS LTD

Pavilion A, Ashwood Park, Ashwood Way, Basingstoke, Hampshire, RG23 8BG, UK
Telephone: +44 (0)1256 312000
Facsimile: +44 (0)1256 312001

This page has been left intentionally blank.

Table of Contents

1. Customer/Manufacturer Information	4
1.1. Customer Information	4
1.2. Manufacturer Information	4
2. Summary of Testing.....	5
2.1. General Information	5
2.2. Summary of Test Results	5
2.3. Methods and Procedures	5
2.4. Deviations from the Test Specification	5
3. Equipment Under Test (EUT)	6
3.1. Identification of Equipment Under Test (EUT)	6
3.2. Description of EUT	6
3.3. Modifications Incorporated in the EUT	6
3.4. Additional Information Related to Testing	7
3.5. Support Equipment	7
4. Operation and Monitoring of the EUT during Testing	8
4.1. Operating Modes	8
4.2. Configuration and Peripherals	8
4.3. Resource Block Allocation	9
5. Measurements, Examinations and Derived Results.....	10
5.1. General Comments	10
5.2. Test Results	11
5.2.1. Transmitter Output Power (EIRP)	11
5.2.2. Transmitter Peak-To-Average Ratio (PAR)	22
5.2.3. Transmitter Occupied Bandwidth	33
5.2.4. Transmitter Frequency Stability (Temperature Variation)	47
5.2.5. Transmitter Frequency Stability (Voltage Variation)	49
6. Measurement Uncertainty	51
7. Report Revision History	52

1. Customer/Manufacturer Information

1.1. Customer Information

Company Name:	Sirin Labs AG
Address:	Muhlentalstrasse 2 8200 Schaffhausen Switzerland

1.2. Manufacturer Information







Manufacturer Name:	Flextronics International Sweden AB
Address:	Datalinjen 3A SE – 583 30 Linköping Sweden

2. Summary of Testing

2.1. General Information

Specification Reference:	47CFR24
Specification Title:	Code of Federal Regulations Volume 47 (Telecommunications): Part 24 Subpart E (Personal Communication Services)
Site Registration:	209735
Location of Testing:	UL VS LTD, Unit 3 Horizon, Wade Road, Kingsland Business Park, Basingstoke, Hampshire, RG24 8AH, United Kingdom
Test Dates:	05 May 2016 to 13 May 2016

2.2. Summary of Test Results

FCC Reference (47CFR)	Measurement	Result
Part 24.232(c)	Transmitter Output Power (EIRP)	
Part 24.232(d)	Peak-to-Average Ratio (PAR)	
Part 2.1049	Transmitter Occupied Bandwidth	
Part 2.1055 / 24.235	Transmitter Frequency Stability (Temperature and Voltage Variation)	
Key to Results		
 = Complied  = Did not comply		

2.3. Methods and Procedures

Reference:	ANSI/TIA-603-D-2010
Title:	Land Mobile FM or PM Communications Equipment, Measurements and performance Standards
Reference:	FCC KDB 971168 D01 v02r02, October 17 2014
Title:	Measurement Guidance for Certification of Licensed Digital Transmitters

2.4. Deviations from the Test Specification

For the measurements contained within this test report, there were no deviations from, additions to, or exclusions from the test specification identified above.

3. Equipment Under Test (EUT)

3.1. Identification of Equipment Under Test (EUT)

Brand Name:	SOLARIN
Model Name or Number:	SR0020-W
Test Sample Serial Number:	0030 <i>(Conducted Sample #1)</i>
Test Sample IMEI:	357232070003163
Hardware Version:	TP1
Software Version:	LRC1TA.1.0.2.3
Handset Cover Material:	Technical leather with titanium coating
FCC ID:	2AIP8I

Brand Name:	SOLARIN
Model Number:	SR0020-W
Test Sample Serial Number:	0108 <i>(Conducted Sample #2)</i>
Test Sample IMEI:	357232070003189
Hardware Version:	TP1
Software Version:	LRC1TA.1.0.2.3
Handset Cover Material:	Technical leather with titanium coating
FCC ID:	2AIP8I

3.2. Description of EUT

The equipment under test was a Mobile device supporting Cellular, WLAN, BT, BTLE, RFID & GPS Technologies.

3.3. Modifications Incorporated in the EUT

No modifications were applied to the EUT during testing.

3.4. Additional Information Related to Testing

Tested Technology:	LTE Band 25		
Type of Equipment	Transceiver		
Channel Bandwidth(s):	1.4, 3, 5, 10, 15 & 20 MHz		
Modulation Type:	QPSK & 16QAM		
Duty Cycle:	100%		
Antenna Type:	Integral		
Antenna Gain:	-1.54 dBi		
Power Supply Requirement:	Nominal	3.9 V	
	Minimum	3.5 V	
	Maximum	4.4 V	
Transmit Frequency Range:	1850 to 1915 MHz		
Channels Tested:	Channel Bandwidth (MHz)	N_{ul}	Frequency of Uplink (MHz)
Bottom Channel	1.4	26047	1850.7
	3	26055	1851.5
	5	26065	1852.5
	10	26090	1855.0
	15	26115	1857.5
	20	26140	1860.0
Middle Channel	All	26365	1882.5
Top Channel	1.4	26683	1914.3
	3	26675	1913.5
	5	26665	1912.5
	10	26640	1910.0
	15	26615	1907.5
	20	26590	1905.0

3.5. Support Equipment

No support equipment was used for the tests shown in this report.

4. Operation and Monitoring of the EUT during Testing

4.1. Operating Modes

The EUT was tested in the following operating mode(s):

- Transmit Mode - The EUT was set to transmit with maximum output power using the required channel bandwidth. QPSK and 16QAM modulations were both tested, with Resource Block allocation as detailed in section 4.3.

4.2. Configuration and Peripherals

The EUT was tested in the following configuration(s):

- The EUT was connected to a Rohde and Schwarz CMW500 LTE system simulator, operating in a transceiver mode.
- Conducted measurements were performed using a conducted sample supplied by the customer. Short 4-wire DC flying leads were connected internally to the device in place of the battery, and exiting through a hole in the casing. These leads were then extended through a connector interface to a laboratory DC power supply.
- For conducted cellular measurements, the EUT RF conducted port was a temporary SMA connector that was connected internally in place of the pcb antenna. The loss of the internal connection to the connector was accounted for in calculations.
- For the conducted tests in this report, the antenna port measured was identified by the manufacturer as Antenna #2.

4.3. Resource Block Allocation

Channel Bandwidth (MHz)	Maximum No. of Resource Blocks	Resource Block / Offset Number							
		Sub Test 1		Sub Test 2		Sub Test 3		Sub Test 4	
		RB	Offset	RB	Offset	RB	Offset	RB	Offset
1.4	6	1	0	1	5	3	2	6	0
3	15	1	0	1	14	8	4	15	0
5	25	1	0	1	24	12	6	25	0
10	50	1	0	1	49	25	12	50	0
15	75	1	0	1	74	36	18	75	0
20	100	1	0	1	99	50	25	100	0

Transmitter Output Power was carried out using sub tests 1, 2, 3 and 4, with both QPSK and 16QAM modulation schemes.

Transmitter Occupied Bandwidth was carried out using sub test 4, for both QPSK and 16QAM modulation schemes.

Transmitter Frequency Stability test was carried out with sub test 4, with a channel bandwidth of 1.4 MHz only.

5. Measurements, Examinations and Derived Results

5.1. General Comments

Measurement uncertainties are evaluated in accordance with current best practice. Our reported expanded uncertainties are based on standard uncertainties, which are multiplied by an appropriate coverage factor to provide a statistical confidence level of approximately 95%. Please refer to *Section 6. Measurement Uncertainty* for details.

In accordance with UKAS requirements all the measurement equipment is on a calibration schedule. All equipment was within the calibration period on the date of testing.

5.2. Test Results

5.2.1. Transmitter Output Power (EIRP)

Test Summary:

Test Engineer:	Keith Tucker	Test Date:	13 May 2016
Test Sample IMEI:	357232070003163		

FCC Reference:	Part 24.232(c)
Test Method Used:	KDB 971168 Section 2.2 footnote 1 & Notes below

Environmental Conditions:

Temperature (°C):	24
Relative Humidity (%):	44

Note(s):

1. The customer stated that the antenna gain is -1.5 dBi.
2. Conducted average power was measured using a calibrated Rohde and Schwarz CMW 500 Wideband Radio Communication Tester.
3. Measurements were performed with the EUT transmitting with QPSK and 16QAM modulation schemes, with resource blocks settings as detailed in section 4.3 of this report.

Test setup:

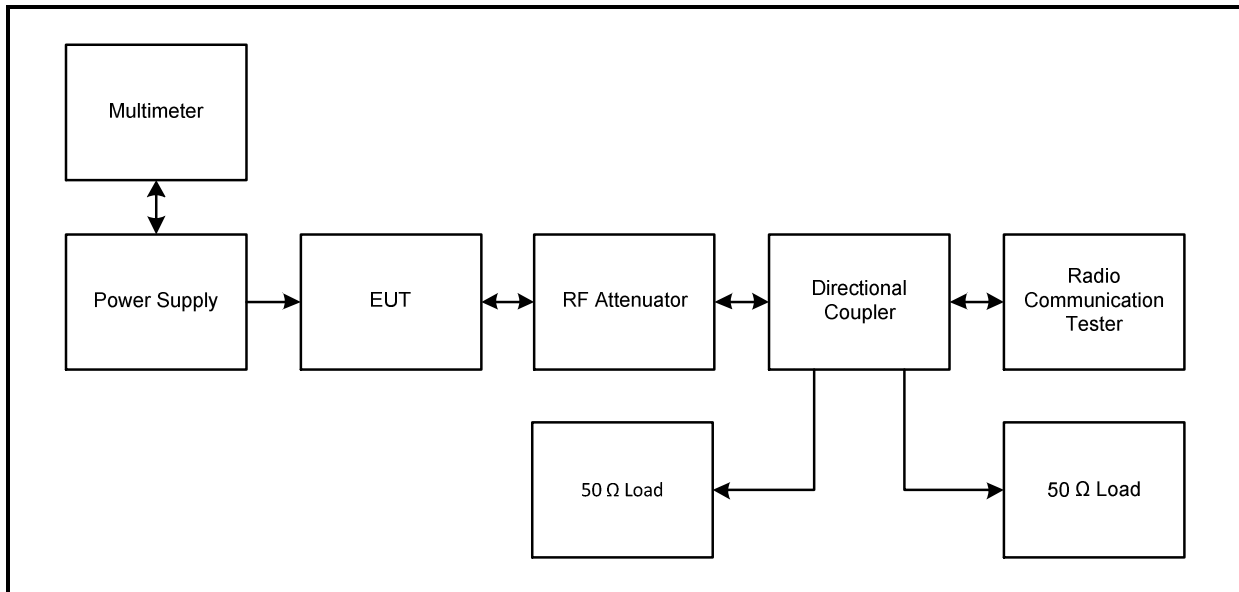

Transmitter Output Power (EIRP) (continued)**Results: 1.4 MHz Channel Bandwidth / Bottom Channel / QPSK**

Frequency (MHz)	Resource Block(s)	Resource Block Offset	Conducted RF Power (dBm)	Antenna Gain (dBi)	EIRP (dBm)	EIRP Limit (dBm)	Margin (dB)	Result
1850.7	6	0	20.2	-1.5	18.7	33.0	14.3	Complied
1850.7	3	2	21.3	-1.5	19.8	33.0	13.2	Complied
1850.7	1	0	21.2	-1.5	19.7	33.0	13.3	Complied
1850.7	1	5	21.3	-1.5	19.8	33.0	13.2	Complied

Results: 1.4 MHz Channel Bandwidth / Bottom Channel / 16QAM

Frequency (MHz)	Resource Block(s)	Resource Block Offset	Conducted RF Power (dBm)	Antenna Gain (dBi)	EIRP (dBm)	EIRP Limit (dBm)	Margin (dB)	Result
1850.7	6	0	19.3	-1.5	17.8	33.0	15.2	Complied
1850.7	3	2	20.3	-1.5	18.8	33.0	14.2	Complied
1850.7	1	0	20.4	-1.5	18.9	33.0	14.1	Complied
1850.7	1	5	20.5	-1.5	19.0	33.0	14.0	Complied

Results: 1.4 MHz Channel Bandwidth / Middle Channel / QPSK

Frequency (MHz)	Resource Block(s)	Resource Block Offset	Conducted RF Power (dBm)	Antenna Gain (dBi)	EIRP (dBm)	EIRP Limit (dBm)	Margin (dB)	Result
1882.5	6	0	19.9	-1.5	18.4	33.0	14.6	Complied
1882.5	3	2	21.1	-1.5	19.6	33.0	13.4	Complied
1882.5	1	0	21.2	-1.5	19.7	33.0	13.3	Complied
1882.5	1	5	21.2	-1.5	19.7	33.0	13.3	Complied

Results: 1.4 MHz Channel Bandwidth / Middle Channel / 16QAM

Frequency (MHz)	Resource Block(s)	Resource Block Offset	Conducted RF Power (dBm)	Antenna Gain (dBi)	EIRP (dBm)	EIRP Limit (dBm)	Margin (dB)	Result
1882.5	6	0	18.9	-1.5	17.4	33.0	15.6	Complied
1882.5	3	2	20.1	-1.5	18.6	33.0	14.4	Complied
1882.5	1	0	20.7	-1.5	19.2	33.0	13.8	Complied
1882.5	1	5	20.8	-1.5	19.3	33.0	13.7	Complied

Transmitter Output Power (EIRP) (continued)**Results: 1.4 MHz Channel Bandwidth / Top Channel / QPSK**

Frequency (MHz)	Resource Block(s)	Resource Block Offset	Conducted RF Power (dBm)	Antenna Gain (dBi)	EIRP (dBm)	EIRP Limit (dBm)	Margin (dB)	Result
1914.3	6	0	19.1	-1.5	17.6	33.0	15.4	Complied
1914.3	3	2	20.0	-1.5	18.5	33.0	14.5	Complied
1914.3	1	0	20.1	-1.5	18.6	33.0	14.4	Complied
1914.3	1	5	20.1	-1.5	18.6	33.0	14.4	Complied

Results: 1.4 MHz Channel Bandwidth / Top Channel / 16QAM

Frequency (MHz)	Resource Block(s)	Resource Block Offset	Conducted RF Power (dBm)	Antenna Gain (dBi)	EIRP (dBm)	EIRP Limit (dBm)	Margin (dB)	Result
1914.3	6	0	18.1	-1.5	16.6	33.0	16.4	Complied
1914.3	3	2	19.4	-1.5	17.9	33.0	15.1	Complied
1914.3	1	0	19.3	-1.5	17.8	33.0	15.2	Complied
1914.3	1	5	19.3	-1.5	17.8	33.0	15.2	Complied

Results: 3 MHz Channel Bandwidth / Bottom Channel / QPSK

Frequency (MHz)	Resource Block(s)	Resource Block Offset	Conducted RF Power (dBm)	Antenna Gain (dBi)	EIRP (dBm)	EIRP Limit (dBm)	Margin (dB)	Result
1851.5	15	0	20.1	-1.5	18.6	33.0	14.4	Complied
1851.5	8	4	20.2	-1.5	18.7	33.0	14.3	Complied
1851.5	1	0	21.4	-1.5	19.9	33.0	13.1	Complied
1851.5	1	14	21.7	-1.5	20.2	33.0	12.8	Complied

Results: 3 MHz Channel Bandwidth / Bottom Channel / 16QAM

Frequency (MHz)	Resource Block(s)	Resource Block Offset	Conducted RF Power (dBm)	Antenna Gain (dBi)	EIRP (dBm)	EIRP Limit (dBm)	Margin (dB)	Result
1851.5	15	0	19.2	-1.5	17.7	33.0	15.3	Complied
1851.5	8	4	19.2	-1.5	17.7	33.0	15.3	Complied
1851.5	1	0	20.5	-1.5	19.0	33.0	14.0	Complied
1851.5	1	14	20.6	-1.5	19.1	33.0	13.9	Complied

Transmitter Output Power (EIRP) (continued)**Results: 3 MHz Channel Bandwidth / Middle Channel / QPSK**

Frequency (MHz)	Resource Block(s)	Resource Block Offset	Conducted RF Power (dBm)	Antenna Gain (dBi)	EIRP (dBm)	EIRP Limit (dBm)	Margin (dB)	Result
1882.5	15	0	20.0	-1.5	18.5	33.0	14.5	Complied
1882.5	8	4	20.2	-1.5	18.7	33.0	14.3	Complied
1882.5	1	0	21.2	-1.5	19.7	33.0	13.3	Complied
1882.5	1	14	21.1	-1.5	19.6	33.0	13.4	Complied

Results: 3 MHz Channel Bandwidth / Middle Channel / 16QAM

Frequency (MHz)	Resource Block(s)	Resource Block Offset	Conducted RF Power (dBm)	Antenna Gain (dBi)	EIRP (dBm)	EIRP Limit (dBm)	Margin (dB)	Result
1882.5	15	0	19.0	-1.5	17.5	33.0	15.5	Complied
1882.5	8	4	19.1	-1.5	17.6	33.0	15.4	Complied
1882.5	1	0	20.7	-1.5	19.2	33.0	13.8	Complied
1882.5	1	14	20.9	-1.5	19.4	33.0	13.6	Complied

Results: 3 MHz Channel Bandwidth / Top Channel / QPSK

Frequency (MHz)	Resource Block(s)	Resource Block Offset	Conducted RF Power (dBm)	Antenna Gain (dBi)	EIRP (dBm)	EIRP Limit (dBm)	Margin (dB)	Result
1913.5	15	0	19.3	-1.5	17.8	33.0	15.2	Complied
1913.5	8	4	19.3	-1.5	17.8	33.0	15.2	Complied
1913.5	1	0	20.3	-1.5	18.8	33.0	14.2	Complied
1913.5	1	14	20.1	-1.5	18.6	33.0	14.4	Complied

Results: 3 MHz Channel Bandwidth / Top Channel / 16QAM

Frequency (MHz)	Resource Block(s)	Resource Block Offset	Conducted RF Power (dBm)	Antenna Gain (dBi)	EIRP (dBm)	EIRP Limit (dBm)	Margin (dB)	Result
1913.5	15	0	18.3	-1.5	16.8	33.0	16.2	Complied
1913.5	8	4	18.5	-1.5	17.0	33.0	16.0	Complied
1913.5	1	0	20.0	-1.5	18.5	33.0	14.5	Complied
1913.5	1	14	19.8	-1.5	18.3	33.0	14.7	Complied

Transmitter Output Power (EIRP) (continued)**Results: 5 MHz Channel Bandwidth / Bottom Channel / QPSK**

Frequency (MHz)	Resource Block(s)	Resource Block Offset	Conducted RF Power (dBm)	Antenna Gain (dBi)	EIRP (dBm)	EIRP Limit (dBm)	Margin (dB)	Result
1852.5	25	0	20.2	-1.5	18.7	33.0	14.3	Complied
1852.5	12	6	20.2	-1.5	18.7	33.0	14.3	Complied
1852.5	1	0	21.3	-1.5	19.8	33.0	13.2	Complied
1852.5	1	24	21.3	-1.5	19.8	33.0	13.2	Complied

Results: 5 MHz Channel Bandwidth / Bottom Channel / 16QAM

Frequency (MHz)	Resource Block(s)	Resource Block Offset	Conducted RF Power (dBm)	Antenna Gain (dBi)	EIRP (dBm)	EIRP Limit (dBm)	Margin (dB)	Result
1852.5	25	0	19.1	-1.5	17.6	33.0	15.4	Complied
1852.5	12	6	19.3	-1.5	17.8	33.0	15.2	Complied
1852.5	1	0	20.7	-1.5	19.2	33.0	13.8	Complied
1852.5	1	24	20.6	-1.5	19.1	33.0	13.9	Complied

Results: 5 MHz Channel Bandwidth / Middle Channel / QPSK

Frequency (MHz)	Resource Block(s)	Resource Block Offset	Conducted RF Power (dBm)	Antenna Gain (dBi)	EIRP (dBm)	EIRP Limit (dBm)	Margin (dB)	Result
1882.5	25	0	20.0	-1.5	18.5	33.0	14.5	Complied
1882.5	12	6	20.1	-1.5	18.6	33.0	14.4	Complied
1882.5	1	0	21.3	-1.5	19.8	33.0	13.2	Complied
1882.5	1	24	21.2	-1.5	19.7	33.0	13.3	Complied

Results: 5 MHz Channel Bandwidth / Middle Channel / 16QAM

Frequency (MHz)	Resource Block(s)	Resource Block Offset	Conducted RF Power (dBm)	Antenna Gain (dBi)	EIRP (dBm)	EIRP Limit (dBm)	Margin (dB)	Result
1882.5	25	0	19.1	-1.5	17.6	33.0	15.4	Complied
1882.5	12	6	19.0	-1.5	17.5	33.0	15.5	Complied
1882.5	1	0	20.4	-1.5	18.9	33.0	14.1	Complied
1882.5	1	24	20.2	-1.5	18.7	33.0	14.3	Complied

Transmitter Output Power (EIRP) (continued)**Results: 5 MHz Channel Bandwidth / Top Channel / QPSK**

Frequency (MHz)	Resource Block(s)	Resource Block Offset	Conducted RF Power (dBm)	Antenna Gain (dBi)	EIRP (dBm)	EIRP Limit (dBm)	Margin (dB)	Result
1912.5	25	0	19.5	-1.5	18.0	33.0	15.0	Complied
1912.5	12	6	19.4	-1.5	17.9	33.0	15.1	Complied
1912.5	1	0	21.0	-1.5	19.5	33.0	13.5	Complied
1912.5	1	24	20.3	-1.5	18.8	33.0	14.2	Complied

Results: 5 MHz Channel Bandwidth / Top Channel / 16QAM

Frequency (MHz)	Resource Block(s)	Resource Block Offset	Conducted RF Power (dBm)	Antenna Gain (dBi)	EIRP (dBm)	EIRP Limit (dBm)	Margin (dB)	Result
1912.5	25	0	18.5	-1.5	17.0	33.0	16.0	Complied
1912.5	12	6	18.5	-1.5	17.0	33.0	16.0	Complied
1912.5	1	0	19.9	-1.5	18.4	33.0	14.6	Complied
1912.5	1	24	19.2	-1.5	17.7	33.0	15.3	Complied

Results: 10 MHz Channel Bandwidth / Bottom Channel / QPSK

Frequency (MHz)	Resource Block(s)	Resource Block Offset	Conducted RF Power (dBm)	Antenna Gain (dBi)	EIRP (dBm)	EIRP Limit (dBm)	Margin (dB)	Result
1855.0	50	0	20.2	-1.5	18.7	33.0	14.3	Complied
1855.0	25	12	20.2	-1.5	18.7	33.0	14.3	Complied
1855.0	1	0	21.4	-1.5	19.9	33.0	13.1	Complied
1855.0	1	49	21.7	-1.5	20.2	33.0	12.8	Complied

Results: 10 MHz Channel Bandwidth / Bottom Channel / 16QAM

Frequency (MHz)	Resource Block(s)	Resource Block Offset	Conducted RF Power (dBm)	Antenna Gain (dBi)	EIRP (dBm)	EIRP Limit (dBm)	Margin (dB)	Result
1855.0	50	0	19.2	-1.5	17.7	33.0	15.3	Complied
1855.0	25	12	19.2	-1.5	17.7	33.0	15.3	Complied
1855.0	1	0	20.6	-1.5	19.1	33.0	13.9	Complied
1855.0	1	49	21.1	-1.5	19.6	33.0	13.4	Complied

Transmitter Output Power (EIRP) (continued)**Results: 10 MHz Channel Bandwidth / Middle Channel / QPSK**

Frequency (MHz)	Resource Block(s)	Resource Block Offset	Conducted RF Power (dBm)	Antenna Gain (dBi)	EIRP (dBm)	EIRP Limit (dBm)	Margin (dB)	Result
1882.5	50	0	20.0	-1.5	18.5	33.0	14.5	Complied
1882.5	25	12	20.2	-1.5	18.7	33.0	14.3	Complied
1882.5	1	0	21.4	-1.5	19.9	33.0	13.1	Complied
1882.5	1	49	21.1	-1.5	19.6	33.0	13.4	Complied

Results: 10 MHz Channel Bandwidth / Middle Channel / 16QAM

Frequency (MHz)	Resource Block(s)	Resource Block Offset	Conducted RF Power (dBm)	Antenna Gain (dBi)	EIRP (dBm)	EIRP Limit (dBm)	Margin (dB)	Result
1882.5	50	0	19.0	-1.5	17.5	33.0	15.5	Complied
1882.5	25	12	19.1	-1.5	17.6	33.0	15.4	Complied
1882.5	1	0	20.6	-1.5	19.1	33.0	13.9	Complied
1882.5	1	49	20.2	-1.5	18.7	33.0	14.3	Complied

Results: 10 MHz Channel Bandwidth / Top Channel / QPSK

Frequency (MHz)	Resource Block(s)	Resource Block Offset	Conducted RF Power (dBm)	Antenna Gain (dBi)	EIRP (dBm)	EIRP Limit (dBm)	Margin (dB)	Result
1910.0	50	0	20.0	-1.5	18.5	33.0	14.5	Complied
1910.0	25	12	20.0	-1.5	18.5	33.0	14.5	Complied
1910.0	1	0	21.5	-1.5	20.0	33.0	13.0	Complied
1910.0	1	49	20.1	-1.5	18.6	33.0	14.4	Complied

Results: 10 MHz Channel Bandwidth / Top Channel / 16QAM

Frequency (MHz)	Resource Block(s)	Resource Block Offset	Conducted RF Power (dBm)	Antenna Gain (dBi)	EIRP (dBm)	EIRP Limit (dBm)	Margin (dB)	Result
1910.0	50	0	19.0	-1.5	17.5	33.0	15.5	Complied
1910.0	25	12	19.1	-1.5	17.6	33.0	15.4	Complied
1910.0	1	0	21.1	-1.5	19.6	33.0	13.4	Complied
1910.0	1	49	19.7	-1.5	18.2	33.0	14.8	Complied

Transmitter Output Power (EIRP) (continued)**Results: 15 MHz Channel Bandwidth / Bottom Channel / QPSK**

Frequency (MHz)	Resource Block(s)	Resource Block Offset	Conducted RF Power (dBm)	Antenna Gain (dBi)	EIRP (dBm)	EIRP Limit (dBm)	Margin (dB)	Result
1857.5	75	0	20.3	-1.5	18.8	33.0	14.2	Complied
1857.5	36	18	20.4	-1.5	18.9	33.0	14.1	Complied
1857.5	1	0	21.6	-1.5	20.1	33.0	12.9	Complied
1857.5	1	74	21.9	-1.5	20.4	33.0	12.6	Complied

Results: 15 MHz Channel Bandwidth / Bottom Channel / 16QAM

Frequency (MHz)	Resource Block(s)	Resource Block Offset	Conducted RF Power (dBm)	Antenna Gain (dBi)	EIRP (dBm)	EIRP Limit (dBm)	Margin (dB)	Result
1857.5	75	0	19.4	-1.5	17.9	33.0	15.1	Complied
1857.5	36	18	19.4	-1.5	17.9	33.0	15.1	Complied
1857.5	1	0	20.8	-1.5	19.3	33.0	13.7	Complied
1857.5	1	74	20.6	-1.5	19.1	33.0	13.9	Complied

Results: 15 MHz Channel Bandwidth / Middle Channel / QPSK

Frequency (MHz)	Resource Block(s)	Resource Block Offset	Conducted RF Power (dBm)	Antenna Gain (dBi)	EIRP (dBm)	EIRP Limit (dBm)	Margin (dB)	Result
1882.5	75	0	20.2	-1.5	18.7	33.0	14.3	Complied
1882.5	36	18	20.2	-1.5	18.7	33.0	14.3	Complied
1882.5	1	0	22.0	-1.5	20.5	33.0	12.5	Complied
1882.5	1	74	21.4	-1.5	19.9	33.0	13.1	Complied

Results: 15 MHz Channel Bandwidth / Middle Channel / 16QAM

Frequency (MHz)	Resource Block(s)	Resource Block Offset	Conducted RF Power (dBm)	Antenna Gain (dBi)	EIRP (dBm)	EIRP Limit (dBm)	Margin (dB)	Result
1882.5	75	0	19.2	-1.5	17.7	33.0	15.3	Complied
1882.5	36	18	19.2	-1.5	17.7	33.0	15.3	Complied
1882.5	1	0	21.6	-1.5	20.1	33.0	12.9	Complied
1882.5	1	74	20.9	-1.5	19.4	33.0	13.6	Complied

Transmitter Output Power (EIRP) (continued)**Results: 15 MHz Channel Bandwidth / Top Channel / QPSK**

Frequency (MHz)	Resource Block(s)	Resource Block Offset	Conducted RF Power (dBm)	Antenna Gain (dBi)	EIRP (dBm)	EIRP Limit (dBm)	Margin (dB)	Result
1907.5	75	0	20.2	-1.5	18.7	33.0	14.3	Complied
1907.5	36	18	20.2	-1.5	18.7	33.0	14.3	Complied
1907.5	1	0	21.5	-1.5	20.0	33.0	13.0	Complied
1907.5	1	74	20.1	-1.5	18.6	33.0	14.4	Complied

Results: 15 MHz Channel Bandwidth / Top Channel / 16QAM

Frequency (MHz)	Resource Block(s)	Resource Block Offset	Conducted RF Power (dBm)	Antenna Gain (dBi)	EIRP (dBm)	EIRP Limit (dBm)	Margin (dB)	Result
1907.5	75	0	19.2	-1.5	17.7	33.0	15.3	Complied
1907.5	36	18	19.2	-1.5	17.7	33.0	15.3	Complied
1907.5	1	0	21.2	-1.5	19.7	33.0	13.3	Complied
1907.5	1	74	19.7	-1.5	18.2	33.0	14.8	Complied

Results: 20 MHz Channel Bandwidth / Bottom Channel / QPSK

Frequency (MHz)	Resource Block(s)	Resource Block Offset	Conducted RF Power (dBm)	Antenna Gain (dBi)	EIRP (dBm)	EIRP Limit (dBm)	Margin (dB)	Result
1860.0	100	0	20.6	-1.5	19.1	33.0	13.9	Complied
1860.0	50	25	20.4	-1.5	18.9	33.0	14.1	Complied
1860.0	1	0	21.5	-1.5	20.0	33.0	13.0	Complied
1860.0	1	99	21.5	-1.5	20.0	33.0	13.0	Complied

Results: 20 MHz Channel Bandwidth / Bottom Channel / 16QAM

Frequency (MHz)	Resource Block(s)	Resource Block Offset	Conducted RF Power (dBm)	Antenna Gain (dBi)	EIRP (dBm)	EIRP Limit (dBm)	Margin (dB)	Result
1860.0	100	0	19.5	-1.5	18.0	33.0	15.0	Complied
1860.0	50	25	19.5	-1.5	18.0	33.0	15.0	Complied
1860.0	1	0	20.8	-1.5	19.3	33.0	13.7	Complied
1860.0	1	99	21.0	-1.5	19.5	33.0	13.5	Complied

Transmitter Output Power (EIRP) (continued)**Results: 20 MHz Channel Bandwidth / Middle Channel / QPSK**

Frequency (MHz)	Resource Block(s)	Resource Block Offset	Conducted RF Power (dBm)	Antenna Gain (dBi)	EIRP (dBm)	EIRP Limit (dBm)	Margin (dB)	Result
1882.5	100	0	20.3	-1.5	18.8	33.0	14.2	Complied
1882.5	50	25	20.1	-1.5	18.6	33.0	14.4	Complied
1882.5	1	0	22.0	-1.5	20.5	33.0	12.5	Complied
1882.5	1	99	21.5	-1.5	20.0	33.0	13.0	Complied

Results: 20 MHz Channel Bandwidth / Middle Channel / 16QAM

Frequency (MHz)	Resource Block(s)	Resource Block Offset	Conducted RF Power (dBm)	Antenna Gain (dBi)	EIRP (dBm)	EIRP Limit (dBm)	Margin (dB)	Result
1882.5	100	0	19.4	-1.5	17.9	33.0	15.1	Complied
1882.5	50	25	19.1	-1.5	17.6	33.0	15.4	Complied
1882.5	1	0	21.6	-1.5	20.1	33.0	12.9	Complied
1882.5	1	99	21.2	-1.5	19.7	33.0	13.3	Complied

Results: 20 MHz Channel Bandwidth / Top Channel / QPSK

Frequency (MHz)	Resource Block(s)	Resource Block Offset	Conducted RF Power (dBm)	Antenna Gain (dBi)	EIRP (dBm)	EIRP Limit (dBm)	Margin (dB)	Result
1905.0	100	0	20.2	-1.5	18.7	33.0	14.3	Complied
1905.0	50	25	19.9	-1.5	18.4	33.0	14.6	Complied
1905.0	1	0	21.5	-1.5	20.0	33.0	13.0	Complied
1905.0	1	99	20.1	-1.5	18.6	33.0	14.4	Complied

Results: 20 MHz Channel Bandwidth / Top Channel / 16QAM

Frequency (MHz)	Resource Block(s)	Resource Block Offset	Conducted RF Power (dBm)	Antenna Gain (dBi)	EIRP (dBm)	EIRP Limit (dBm)	Margin (dB)	Result
1905.0	100	0	19.3	-1.5	17.8	33.0	15.2	Complied
1905.0	50	25	19.1	-1.5	17.6	33.0	15.4	Complied
1905.0	1	0	21.0	-1.5	19.5	33.0	13.5	Complied
1905.0	1	99	19.5	-1.5	18.0	33.0	15.0	Complied

Transmitter Output Power (EIRP) (continued)**Test Equipment Used:**

Asset No.	Instrument	Manufacturer	Type No.	Serial No.	Date Calibration Due	Cal. Interval (Months)
M2002	Thermohygrometer	Testo	608-H1	45041825	02 Apr 2017	12
M1869	Wideband Radio Comms Tester	Rohde & Schwarz	CMW500	145923	05 Apr 2017	12
A2845	Attenuator	Radiall	R411.806.121	24325927	Calibrated before use	-
A2844	Attenuator	Radiall	R411.803.121	23404066	Calibrated before use	-
A2504	Directional Coupler	AtlanTecRF	CDC-003060-10	13122501839	Calibrated before use	-
S0577	Power Supply	TTi	CPX400S	436670	Calibrated before use	-
M1269	Multimeter	Fluke	179	90250210	26 May 2016	12
M1835	Signal Analyser	Rohde & Schwarz	FSV30	103050	26 Feb 2017	12

5.2.2. Transmitter Peak-To-Average Ratio (PAR)**Test Summary:**

Test Engineer:	Keith Tucker	Test Date:	13 May 2016
Test Sample IMEI:	357232070003163		

FCC Reference:	Part 24.232(d)
Test Method Used:	KDB 971168 Section 5.7.2

Environmental Conditions:

Temperature (°C):	24
Relative Humidity (%):	44

Note(s):

1. The peak (P_{Pk}) and average (P_{Avg}) power were measured using the internal power measurement function of a calibrated Rohde and Schwarz CMW 500 Wideband Radio Communication Tester in accordance with current Rohde and Schwarz application notes.
2. The PAPR was determined using the following calculation:

$$PAPR (dB) = P_{Pk} (dBm) - P_{Avg} (dBm).$$

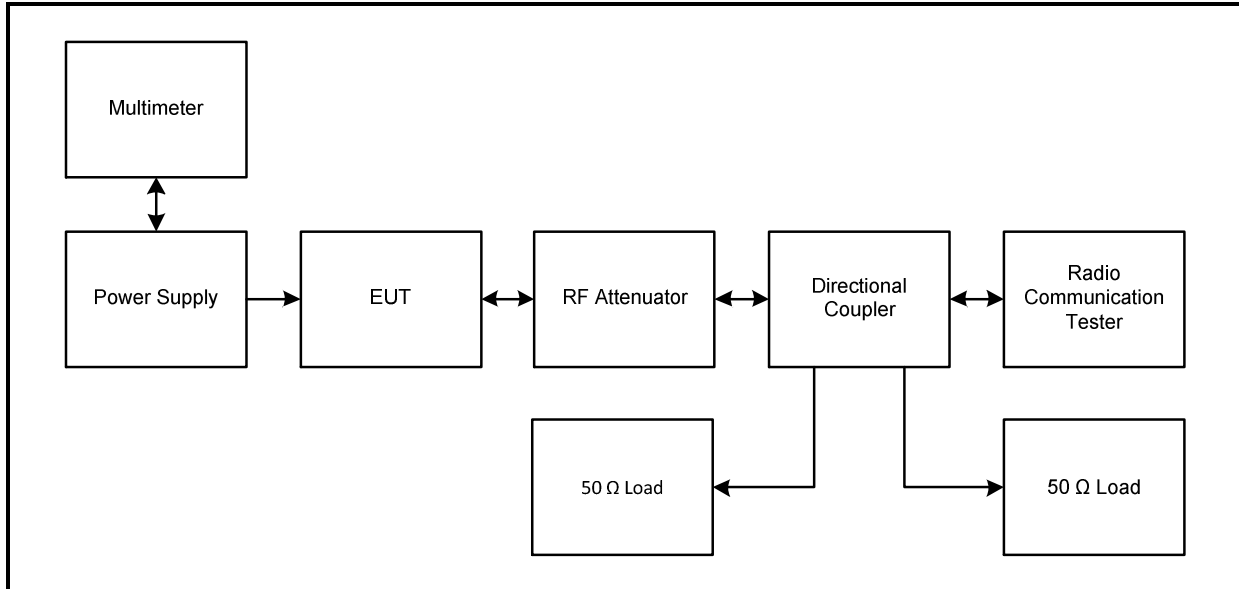
Test setup:

Transmitter Peak-To-Average Ratio (PAR) (continued)**Results: 1.4 MHz Channel Bandwidth / Bottom Channel / QPSK**

Frequency (MHz)	Resource Block(s)	Resource Block Offset	P _{Pk} (dBm)	P _{Avg} (dBm)	PAR (dB)	Ratio Limit (dB)	Margin (dB)	Result
1850.7	6	0	25.5	20.2	5.3	13.0	7.7	Complied
1850.7	3	2	25.3	21.3	4.0	13.0	9.0	Complied
1850.7	1	0	25.0	21.2	3.8	13.0	9.2	Complied
1850.7	1	5	25.0	21.3	3.7	13.0	9.3	Complied

Results: 1.4 MHz Channel Bandwidth / Bottom Channel / 16QAM

Frequency (MHz)	Resource Block(s)	Resource Block Offset	P _{Pk} (dBm)	P _{Avg} (dBm)	PAR (dB)	Ratio Limit (dB)	Margin (dB)	Result
1850.7	6	0	25.5	19.3	6.2	13.0	6.8	Complied
1850.7	3	2	25.2	20.3	4.9	13.0	8.1	Complied
1850.7	1	0	25.0	20.4	4.6	13.0	8.4	Complied
1850.7	1	5	25.1	20.5	4.6	13.0	8.4	Complied

Results: 1.4 MHz Channel Bandwidth / Middle Channel / QPSK

Frequency (MHz)	Resource Block(s)	Resource Block Offset	P _{Pk} (dBm)	P _{Avg} (dBm)	PAR (dB)	Ratio Limit (dB)	Margin (dB)	Result
1882.5	6	0	25.8	19.9	5.9	13.0	7.1	Complied
1882.5	3	2	25.9	21.1	4.8	13.0	8.2	Complied
1882.5	1	0	25.7	21.2	4.5	13.0	8.5	Complied
1882.5	1	5	25.8	21.2	4.6	13.0	8.4	Complied

Results: 1.4 MHz Channel Bandwidth / Middle Channel / 16QAM

Frequency (MHz)	Resource Block(s)	Resource Block Offset	P _{Pk} (dBm)	P _{Avg} (dBm)	PAR (dB)	Ratio Limit (dB)	Margin (dB)	Result
1882.5	6	0	25.2	18.9	6.3	13.0	6.7	Complied
1882.5	3	2	25.9	20.1	5.8	13.0	7.2	Complied
1882.5	1	0	25.7	20.7	5.0	13.0	8.0	Complied
1882.5	1	5	25.8	20.8	5.0	13.0	8.0	Complied

Transmitter Peak-To-Average Ratio (PAR) (continued)**Results: 1.4 MHz Channel Bandwidth / Top Channel / QPSK**

Frequency (MHz)	Resource Block(s)	Resource Block Offset	P _{PK} (dBm)	P _{Avg} (dBm)	PAR (dB)	Ratio Limit (dB)	Margin (dB)	Result
1914.3	6	0	24.5	19.1	5.4	13.0	7.6	Complied
1914.3	3	2	24.0	20.0	4.0	13.0	9.0	Complied
1914.3	1	0	23.7	20.1	3.6	13.0	9.4	Complied
1914.3	1	5	23.6	20.1	3.5	13.0	9.5	Complied

Results: 1.4 MHz Channel Bandwidth / Top Channel / 16QAM

Frequency (MHz)	Resource Block(s)	Resource Block Offset	P _{PK} (dBm)	P _{Avg} (dBm)	PAR (dB)	Ratio Limit (dB)	Margin (dB)	Result
1914.3	6	0	24.4	18.1	6.3	13.0	6.7	Complied
1914.3	3	2	23.9	19.4	4.5	13.0	8.5	Complied
1914.3	1	0	23.8	19.3	4.5	13.0	8.5	Complied
1914.3	1	5	23.6	19.3	4.3	13.0	8.7	Complied

Results: 3 MHz Channel Bandwidth / Bottom Channel / QPSK

Frequency (MHz)	Resource Block(s)	Resource Block Offset	P _{PK} (dBm)	P _{Avg} (dBm)	PAR (dB)	Ratio Limit (dB)	Margin (dB)	Result
1851.5	15	0	25.4	19.2	6.2	13.0	6.8	Complied
1851.5	8	4	25.3	19.2	6.1	13.0	6.9	Complied
1851.5	1	0	25.0	20.5	4.5	13.0	8.5	Complied
1851.5	1	14	25.3	20.6	4.7	13.0	8.3	Complied

Results: 3 MHz Channel Bandwidth / Bottom Channel / 16QAM

Frequency (MHz)	Resource Block(s)	Resource Block Offset	P _{PK} (dBm)	P _{Avg} (dBm)	PAR (dB)	Ratio Limit (dB)	Margin (dB)	Result
1851.5	15	0	25.4	19.2	6.2	13.0	6.8	Complied
1851.5	8	4	25.3	19.2	6.1	13.0	6.9	Complied
1851.5	1	0	25.0	20.5	4.5	13.0	8.5	Complied
1851.5	1	14	25.3	20.6	4.7	13.0	8.3	Complied

Transmitter Peak-To-Average Ratio (PAR) (continued)**Results: 3 MHz Channel Bandwidth / Middle Channel / QPSK**

Frequency (MHz)	Resource Block(s)	Resource Block Offset	P _{PK} (dBm)	P _{Avg} (dBm)	PAR (dB)	Ratio Limit (dB)	Margin (dB)	Result
1882.5	15	0	26.0	20.0	6.0	13.0	7.0	Complied
1882.5	8	4	25.5	20.2	5.3	13.0	7.7	Complied
1882.5	1	0	25.7	21.2	4.5	13.0	8.5	Complied
1882.5	1	14	25.8	21.1	4.7	13.0	8.3	Complied

Results: 3 MHz Channel Bandwidth / Middle Channel / 16QAM

Frequency (MHz)	Resource Block(s)	Resource Block Offset	P _{PK} (dBm)	P _{Avg} (dBm)	PAR (dB)	Ratio Limit (dB)	Margin (dB)	Result
1882.5	15	0	25.0	19.0	6.0	13.0	7.0	Complied
1882.5	8	4	24.8	19.1	5.7	13.0	7.3	Complied
1882.5	1	0	25.7	20.7	5.0	13.0	8.0	Complied
1882.5	1	14	25.8	20.9	4.9	13.0	8.1	Complied

Results: 3 MHz Channel Bandwidth / Top Channel / QPSK

Frequency (MHz)	Resource Block(s)	Resource Block Offset	P _{PK} (dBm)	P _{Avg} (dBm)	PAR (dB)	Ratio Limit (dB)	Margin (dB)	Result
1913.5	15	0	24.5	19.3	5.2	13.0	7.8	Complied
1913.5	8	4	24.2	19.3	4.9	13.0	8.1	Complied
1913.5	1	0	24.1	20.3	3.8	13.0	9.2	Complied
1913.5	1	14	23.7	20.1	3.6	13.0	9.4	Complied

Results: 3 MHz Channel Bandwidth / Top Channel / 16QAM

Frequency (MHz)	Resource Block(s)	Resource Block Offset	P _{PK} (dBm)	P _{Avg} (dBm)	PAR (dB)	Ratio Limit (dB)	Margin (dB)	Result
1913.5	15	0	24.8	18.3	6.5	13.0	6.5	Complied
1913.5	8	4	24.2	18.5	5.7	13.0	7.3	Complied
1913.5	1	0	24.2	20.0	4.2	13.0	8.8	Complied
1913.5	1	14	23.8	19.8	4.0	13.0	9.0	Complied

Transmitter Peak-To-Average Ratio (PAR) (continued)**Results: 5 MHz Channel Bandwidth / Bottom Channel / QPSK**

Frequency (MHz)	Resource Block(s)	Resource Block Offset	P _{Pk} (dBm)	P _{Avg} (dBm)	PAR (dB)	Ratio Limit (dB)	Margin (dB)	Result
1852.5	25	0	25.9	20.2	5.7	13.0	7.3	Complied
1852.5	12	6	25.4	20.2	5.2	13.0	7.8	Complied
1852.5	1	0	25.0	21.3	3.7	13.0	9.3	Complied
1852.5	1	24	25.4	21.3	4.1	13.0	8.9	Complied

Results: 5 MHz Channel Bandwidth / Bottom Channel / 16QAM

Frequency (MHz)	Resource Block(s)	Resource Block Offset	P _{Pk} (dBm)	P _{Avg} (dBm)	PAR (dB)	Ratio Limit (dB)	Margin (dB)	Result
1852.5	25	0	25.8	19.1	6.7	13.0	6.3	Complied
1852.5	12	6	25.4	19.3	6.1	13.0	6.9	Complied
1852.5	1	0	25.0	20.7	4.3	13.0	8.7	Complied
1852.5	1	24	25.4	20.6	4.8	13.0	8.2	Complied

Results: 5 MHz Channel Bandwidth / Middle Channel / QPSK

Frequency (MHz)	Resource Block(s)	Resource Block Offset	P _{Pk} (dBm)	P _{Avg} (dBm)	PAR (dB)	Ratio Limit (dB)	Margin (dB)	Result
1882.5	25	0	25.9	20.0	5.9	13.0	7.1	Complied
1882.5	12	6	25.4	20.1	5.3	13.0	7.7	Complied
1882.5	1	0	25.7	21.3	4.4	13.0	8.6	Complied
1882.5	1	24	25.8	21.2	4.6	13.0	8.4	Complied

Results: 5 MHz Channel Bandwidth / Middle Channel / 16QAM

Frequency (MHz)	Resource Block(s)	Resource Block Offset	P _{Pk} (dBm)	P _{Avg} (dBm)	PAR (dB)	Ratio Limit (dB)	Margin (dB)	Result
1882.5	25	0	25.5	19.1	6.4	13.0	6.6	Complied
1882.5	12	6	24.8	19.0	5.8	13.0	7.2	Complied
1882.5	1	0	25.7	20.4	5.3	13.0	7.7	Complied
1882.5	1	24	25.8	20.2	5.6	13.0	7.4	Complied

Transmitter Peak-To-Average Ratio (PAR) (continued)**Results: 5 MHz Channel Bandwidth / Top Channel / QPSK**

Frequency (MHz)	Resource Block(s)	Resource Block Offset	P _{Pk} (dBm)	P _{Avg} (dBm)	PAR (dB)	Ratio Limit (dB)	Margin (dB)	Result
1912.5	25	0	24.7	19.5	5.2	13.0	7.8	Complied
1912.5	12	6	24.4	19.4	5.0	13.0	8.0	Complied
1912.5	1	0	24.5	21.0	3.5	13.0	9.5	Complied
1912.5	1	24	23.7	20.3	3.4	13.0	9.6	Complied

Results: 5 MHz Channel Bandwidth / Top Channel / 16QAM

Frequency (MHz)	Resource Block(s)	Resource Block Offset	P _{Pk} (dBm)	P _{Avg} (dBm)	PAR (dB)	Ratio Limit (dB)	Margin (dB)	Result
1912.5	25	0	24.7	18.5	6.2	13.0	6.8	Complied
1912.5	12	6	24.4	18.5	5.9	13.0	7.1	Complied
1912.5	1	0	24.6	19.9	4.7	13.0	8.3	Complied
1912.5	1	24	23.8	19.2	4.6	13.0	8.4	Complied

Results: 10 MHz Channel Bandwidth / Bottom Channel / QPSK

Frequency (MHz)	Resource Block(s)	Resource Block Offset	P _{Pk} (dBm)	P _{Avg} (dBm)	PAR (dB)	Ratio Limit (dB)	Margin (dB)	Result
1855.0	50	0	26.2	20.2	6.0	13.0	7.0	Complied
1855.0	25	12	25.6	20.2	5.4	13.0	7.6	Complied
1855.0	1	0	25.3	21.4	3.9	13.0	9.1	Complied
1855.0	1	49	25.8	21.7	4.1	13.0	8.9	Complied

Results: 10 MHz Channel Bandwidth / Bottom Channel / 16QAM

Frequency (MHz)	Resource Block(s)	Resource Block Offset	P _{Pk} (dBm)	P _{Avg} (dBm)	PAR (dB)	Ratio Limit (dB)	Margin (dB)	Result
1855.0	50	0	25.9	19.2	6.7	13.0	6.3	Complied
1855.0	25	12	25.4	19.2	6.2	13.0	6.8	Complied
1855.0	1	0	25.4	20.6	4.8	13.0	8.2	Complied
1855.0	1	49	25.9	21.1	4.8	13.0	8.2	Complied

Transmitter Peak-To-Average Ratio (PAR) (continued)**Results: 10 MHz Channel Bandwidth / Middle Channel / QPSK**

Frequency (MHz)	Resource Block(s)	Resource Block Offset	P _{Pk} (dBm)	P _{Avg} (dBm)	PAR (dB)	Ratio Limit (dB)	Margin (dB)	Result
1882.5	50	0	26.4	20.0	6.4	13.0	6.6	Complied
1882.5	25	12	25.7	20.2	5.5	13.0	7.5	Complied
1882.5	1	0	25.8	21.4	4.4	13.0	8.6	Complied
1882.5	1	49	25.7	21.1	4.6	13.0	8.4	Complied

Results: 10 MHz Channel Bandwidth / Middle Channel / 16QAM

Frequency (MHz)	Resource Block(s)	Resource Block Offset	P _{Pk} (dBm)	P _{Avg} (dBm)	PAR (dB)	Ratio Limit (dB)	Margin (dB)	Result
1882.5	50	0	26.0	19.0	7.0	13.0	6.0	Complied
1882.5	25	12	25.0	19.1	5.9	13.0	7.1	Complied
1882.5	1	0	25.8	20.6	5.2	13.0	7.8	Complied
1882.5	1	49	25.8	20.2	5.6	13.0	7.4	Complied

Results: 10 MHz Channel Bandwidth / Top Channel / QPSK

Frequency (MHz)	Resource Block(s)	Resource Block Offset	P _{Pk} (dBm)	P _{Avg} (dBm)	PAR (dB)	Ratio Limit (dB)	Margin (dB)	Result
1910.0	50	0	25.8	20.0	5.8	13.0	7.2	Complied
1910.0	25	12	25.1	20.0	5.1	13.0	7.9	Complied
1910.0	1	0	25.3	21.5	3.8	13.0	9.2	Complied
1910.0	1	49	24.0	20.1	3.9	13.0	9.1	Complied

Results: 10 MHz Channel Bandwidth / Top Channel / 16QAM

Frequency (MHz)	Resource Block(s)	Resource Block Offset	P _{Pk} (dBm)	P _{Avg} (dBm)	PAR (dB)	Ratio Limit (dB)	Margin (dB)	Result
1910.0	50	0	25.5	19.0	6.5	13.0	6.5	Complied
1910.0	25	12	25.2	19.1	6.1	13.0	6.9	Complied
1910.0	1	0	25.3	21.1	4.2	13.0	8.8	Complied
1910.0	1	49	24.1	19.7	4.4	13.0	8.6	Complied

Transmitter Peak-To-Average Ratio (PAR) (continued)**Results: 15 MHz Channel Bandwidth / Bottom Channel / QPSK**

Frequency (MHz)	Resource Block(s)	Resource Block Offset	P _{PK} (dBm)	P _{Avg} (dBm)	PAR (dB)	Ratio Limit (dB)	Margin (dB)	Result
1857.5	75	0	26.3	20.3	6.0	13.0	7.0	Complied
1857.5	36	18	25.7	20.4	5.3	13.0	7.7	Complied
1857.5	1	0	25.5	21.6	3.9	13.0	9.1	Complied
1857.5	1	74	25.9	21.9	4.0	13.0	9.0	Complied

Results: 15 MHz Channel Bandwidth / Bottom Channel / 16QAM

Frequency (MHz)	Resource Block(s)	Resource Block Offset	P _{PK} (dBm)	P _{Avg} (dBm)	PAR (dB)	Ratio Limit (dB)	Margin (dB)	Result
1857.5	75	0	26.2	19.4	6.8	13.0	6.2	Complied
1857.5	36	18	25.6	19.4	6.2	13.0	6.8	Complied
1857.5	1	0	25.6	20.8	4.8	13.0	8.2	Complied
1857.5	1	74	25.9	20.6	5.3	13.0	7.7	Complied

Results: 15 MHz Channel Bandwidth / Middle Channel / QPSK

Frequency (MHz)	Resource Block(s)	Resource Block Offset	P _{PK} (dBm)	P _{Avg} (dBm)	PAR (dB)	Ratio Limit (dB)	Margin (dB)	Result
1882.5	75	0	26.4	20.2	6.2	13.0	6.8	Complied
1882.5	36	18	25.7	20.2	5.5	13.0	7.5	Complied
1882.5	1	0	25.9	22.0	3.9	13.0	9.1	Complied
1882.5	1	74	25.7	21.4	4.3	13.0	8.7	Complied

Results: 15 MHz Channel Bandwidth / Middle Channel / 16QAM

Frequency (MHz)	Resource Block(s)	Resource Block Offset	P _{PK} (dBm)	P _{Avg} (dBm)	PAR (dB)	Ratio Limit (dB)	Margin (dB)	Result
1882.5	75	0	26.3	19.2	7.1	13.0	5.9	Complied
1882.5	36	18	25.6	19.2	6.4	13.0	6.6	Complied
1882.5	1	0	26.0	21.6	4.4	13.0	8.6	Complied
1882.5	1	74	25.8	20.9	4.9	13.0	8.1	Complied

Transmitter Peak-To-Average Ratio (PAR) (continued)**Results: 15 MHz Channel Bandwidth / Top Channel / QPSK**

Frequency (MHz)	Resource Block(s)	Resource Block Offset	P _{Pk} (dBm)	P _{Avg} (dBm)	PAR (dB)	Ratio Limit (dB)	Margin (dB)	Result
1907.5	75	0	25.9	20.2	5.7	13.0	7.3	Complied
1907.5	36	18	25.4	20.2	5.2	13.0	7.8	Complied
1907.5	1	0	25.4	21.5	3.9	13.0	9.1	Complied
1907.5	1	74	24.2	20.1	4.1	13.0	8.9	Complied

Results: 15 MHz Channel Bandwidth / Top Channel / 16QAM

Frequency (MHz)	Resource Block(s)	Resource Block Offset	P _{Pk} (dBm)	P _{Avg} (dBm)	PAR (dB)	Ratio Limit (dB)	Margin (dB)	Result
1907.5	75	0	25.8	19.2	6.6	13.0	6.4	Complied
1907.5	36	18	25.5	19.2	6.3	13.0	6.7	Complied
1907.5	1	0	25.4	21.2	4.2	13.0	8.8	Complied
1907.5	1	74	24.2	19.7	4.5	13.0	8.5	Complied

Results: 20 MHz Channel Bandwidth / Bottom Channel / QPSK

Frequency (MHz)	Resource Block(s)	Resource Block Offset	P _{Pk} (dBm)	P _{Avg} (dBm)	PAR (dB)	Ratio Limit (dB)	Margin (dB)	Result
1860.0	100	0	26.2	20.6	5.6	13.0	7.4	Complied
1860.0	50	25	25.5	20.4	5.1	13.0	7.9	Complied
1860.0	1	0	25.1	21.5	3.6	13.0	9.4	Complied
1860.0	1	99	25.3	21.5	3.8	13.0	9.2	Complied

Results: 20 MHz Channel Bandwidth / Bottom Channel / 16QAM

Frequency (MHz)	Resource Block(s)	Resource Block Offset	P _{Pk} (dBm)	P _{Avg} (dBm)	PAR (dB)	Ratio Limit (dB)	Margin (dB)	Result
1860.0	100	0	26.0	19.5	6.5	13.0	6.5	Complied
1860.0	50	25	25.4	19.5	5.9	13.0	7.1	Complied
1860.0	1	0	25.1	20.8	4.3	13.0	8.7	Complied
1860.0	1	99	25.3	21.0	4.3	13.0	8.7	Complied

Transmitter Peak-To-Average Ratio (PAR) (continued)**Results: 20 MHz Channel Bandwidth / Middle Channel / QPSK**

Frequency (MHz)	Resource Block(s)	Resource Block Offset	P _{Pk} (dBm)	P _{Avg} (dBm)	PAR (dB)	Ratio Limit (dB)	Margin (dB)	Result
1882.5	100	0	26.3	20.3	6.0	13.0	7.0	Complied
1882.5	50	25	25.9	20.1	5.8	13.0	7.2	Complied
1882.5	1	0	26.1	22.0	4.1	13.0	8.9	Complied
1882.5	1	99	25.8	21.5	4.3	13.0	8.7	Complied

Results: 20 MHz Channel Bandwidth / Middle Channel / 16QAM

Frequency (MHz)	Resource Block(s)	Resource Block Offset	P _{Pk} (dBm)	P _{Avg} (dBm)	PAR (dB)	Ratio Limit (dB)	Margin (dB)	Result
1882.5	100	0	26.5	19.4	7.1	13.0	5.9	Complied
1882.5	50	25	25.9	19.1	6.8	13.0	6.2	Complied
1882.5	1	0	26.2	21.6	4.6	13.0	8.4	Complied
1882.5	1	99	26.0	21.2	4.8	13.0	8.2	Complied

Results: 20 MHz Channel Bandwidth / Top Channel / QPSK

Frequency (MHz)	Resource Block(s)	Resource Block Offset	P _{Pk} (dBm)	P _{Avg} (dBm)	PAR (dB)	Ratio Limit (dB)	Margin (dB)	Result
1905.0	100	0	25.9	20.2	5.7	13.0	7.3	Complied
1905.0	50	25	25.6	19.9	5.7	13.0	7.3	Complied
1905.0	1	0	25.5	21.5	4.0	13.0	9.0	Complied
1905.0	1	99	24.3	20.1	4.2	13.0	8.8	Complied

Results: 20 MHz Channel Bandwidth / Top Channel / 16QAM

Frequency (MHz)	Resource Block(s)	Resource Block Offset	P _{Pk} (dBm)	P _{Avg} (dBm)	PAR (dB)	Ratio Limit (dB)	Margin (dB)	Result
1905.0	100	0	25.9	19.3	6.6	13.0	6.4	Complied
1905.0	50	25	25.4	19.1	6.3	13.0	6.7	Complied
1905.0	1	0	25.6	21.0	4.6	13.0	8.4	Complied
1905.0	1	99	24.5	19.5	5.0	13.0	8.0	Complied

Transmitter Peak-To-Average Ratio (PAR) (continued)**Test Equipment Used:**

Asset No.	Instrument	Manufacturer	Type No.	Serial No.	Date Calibration Due	Cal. Interval (Months)
M2002	Thermohygrometer	Testo	608-H1	45041825	02 Apr 2017	12
M1869	Wideband Radio Comms Tester	Rohde & Schwarz	CMW500	145923	05 Apr 2017	12
A2845	Attenuator	Radiall	R411.806.121	24325927	Calibrated before use	-
A2844	Attenuator	Radiall	R411.803.121	23404066	Calibrated before use	-
A2504	Directional Coupler	AtlanTecRF	CDC-003060-10	13122501839	Calibrated before use	-
S0577	Power Supply	TTi	CPX400S	436670	Calibrated before use	-
M1269	Multimeter	Fluke	179	90250210	26 May 2016	12
M1835	Signal Analyser	Rohde & Schwarz	FSV30	103050	26 Feb 2017	12

5.2.3. Transmitter Occupied Bandwidth

Test Summary:

Test Engineer:	Keith Tucker	Test Date:	13 May 2016
Test Sample IMEI:	357232070003163		

FCC Reference:	Part 2.1049
Test Method Used:	KDB 971168 Section 4.2

Environmental Conditions:

Temperature (°C):	24
Relative Humidity (%):	44

Note(s):

1. Occupied bandwidth (99% bandwidth) was measured using a signal analyser occupied bandwidth function.
2. Measurements were performed with the EUT transmitting with QPSK and 16QAM modulation schemes, with resource blocks settings as detailed in section 4.3 of this report.
3. The RF port of the EUT was connected to the signal analyser via RF cables, directional coupler and suitable attenuation.

Test setup:

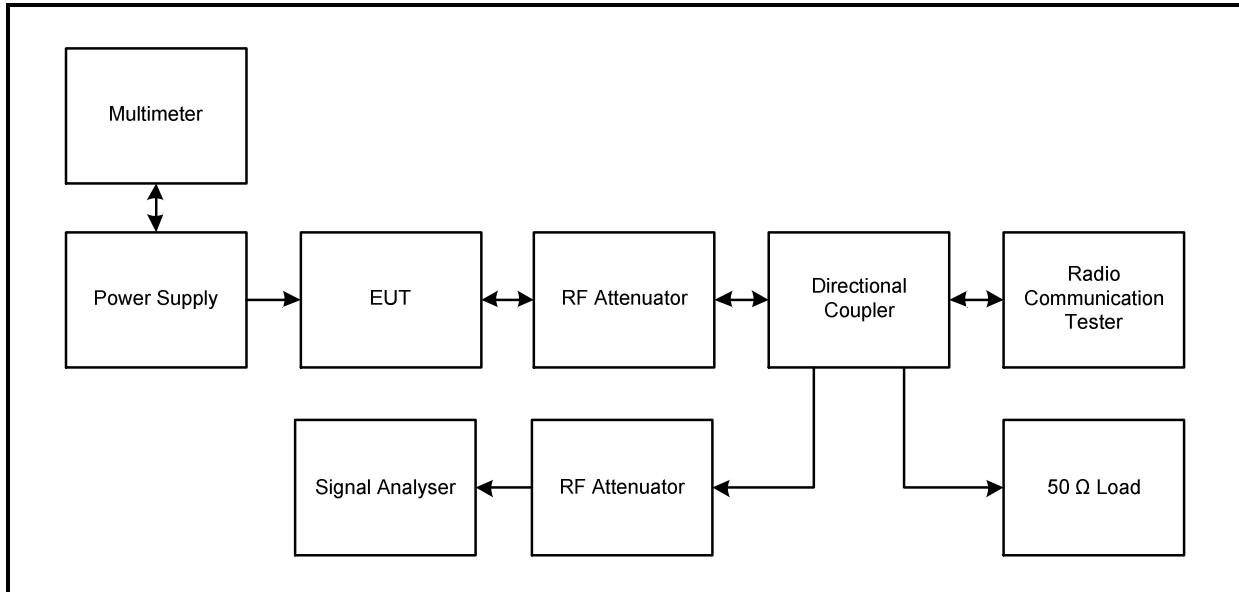

Transmitter Occupied Bandwidth (continued)

Results: 1.4 MHz Channel Bandwidth / QPSK

Channel	Resource Block(s)	Resource Block Offset	Resolution Bandwidth (kHz)	Video Bandwidth (kHz)	Occupied Bandwidth (MHz)
Bottom	6	0	30	100	1.106
Middle	6	0	30	100	1.090
Top	6	0	30	100	1.098

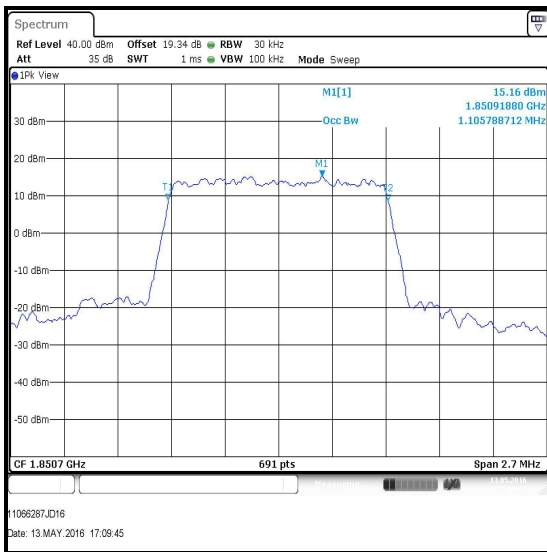

Bottom Channel / QPSK

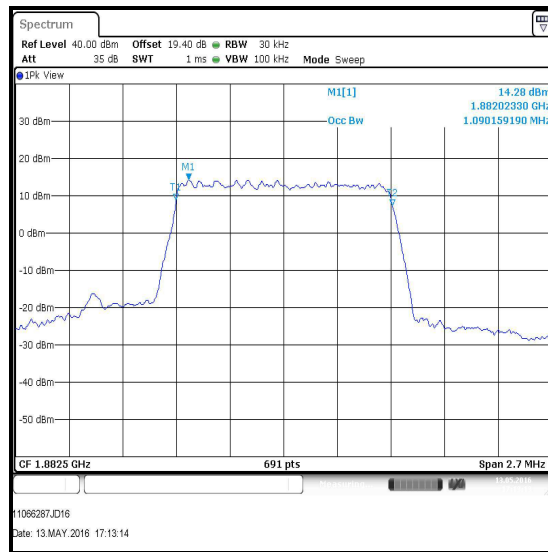

Middle Channel / QPSK

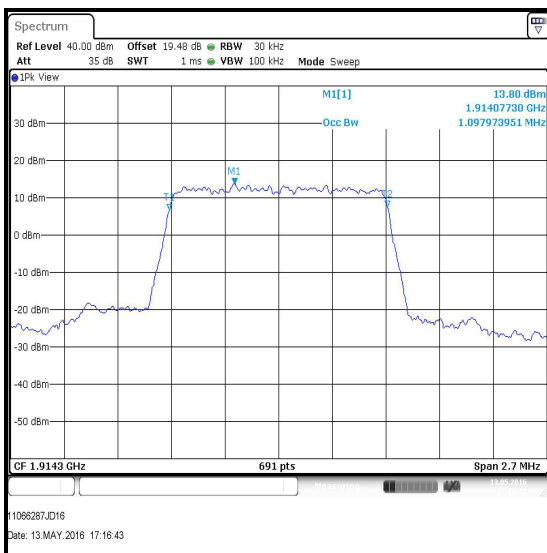

Top Channel / QPSK

Transmitter Occupied Bandwidth (continued)

Results: 1.4 MHz Channel Bandwidth / 16QAM

Channel	Resource Block(s)	Resource Block Offset	Resolution Bandwidth (kHz)	Video Bandwidth (kHz)	Occupied Bandwidth (MHz)
Bottom	6	0	30	100	1.094
Middle	6	0	30	100	1.098
Top	6	0	30	100	1.098

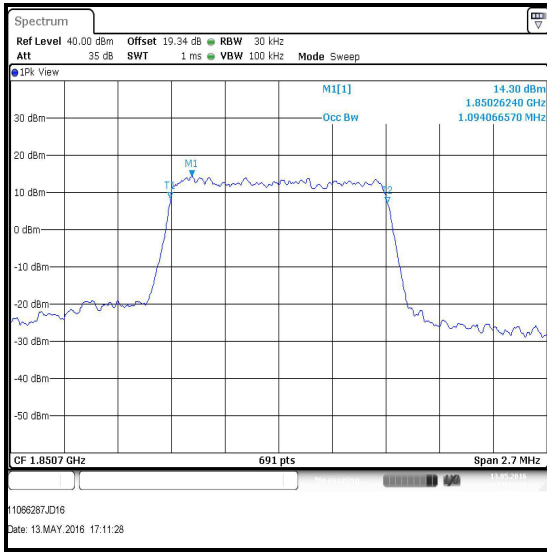

Bottom Channel / 16QAM

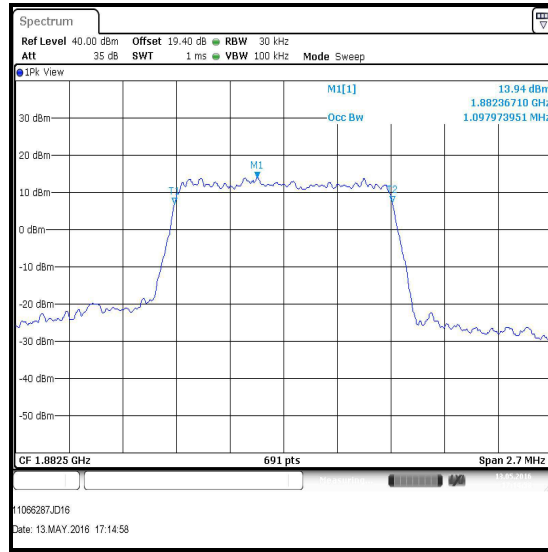

Middle Channel / 16QAM

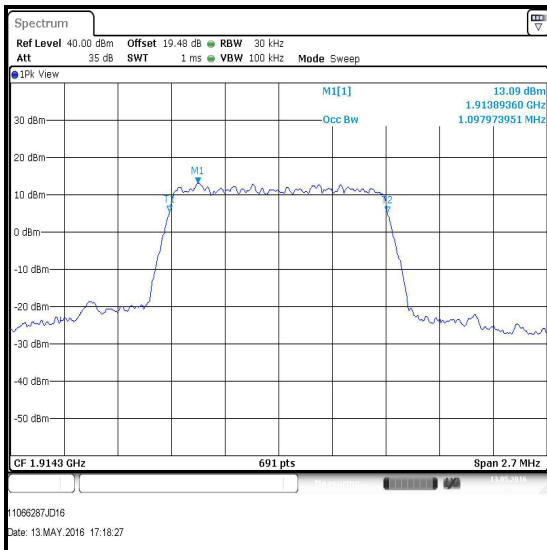

Top Channel / 16QAM

Transmitter Occupied Bandwidth (continued)

Results: 3 MHz Channel Bandwidth / QPSK

Channel	Resource Block(s)	Resource Block Offset	Resolution Bandwidth (kHz)	Video Bandwidth (kHz)	Occupied Bandwidth (MHz)
Bottom	15	0	100	300	2.755
Middle	15	0	100	300	2.745
Top	15	0	100	300	2.745

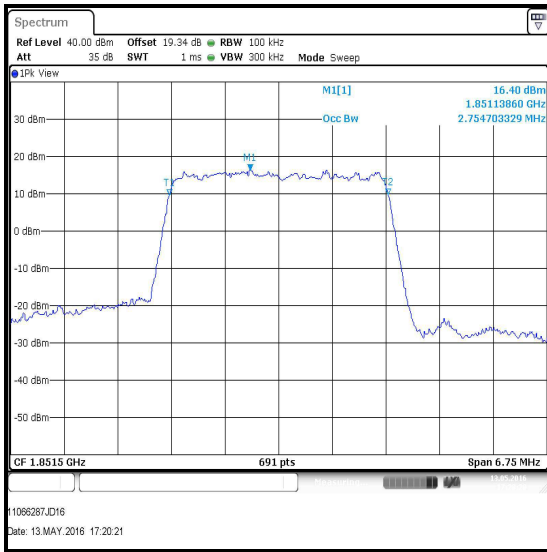

Bottom Channel / QPSK

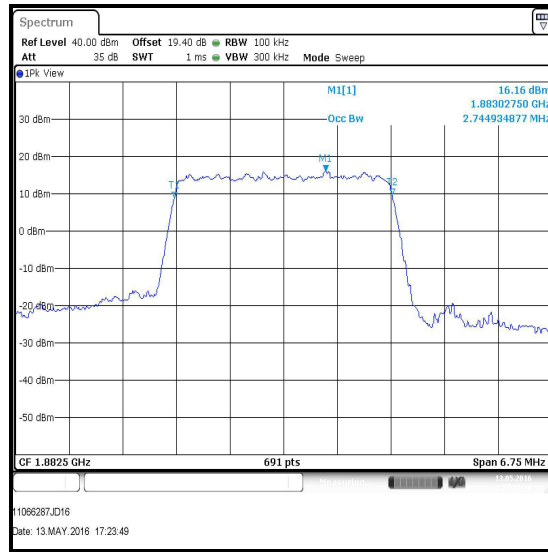

Middle Channel / QPSK

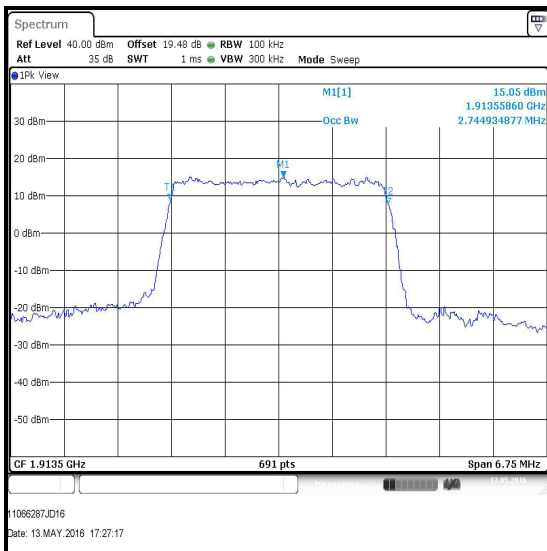

Top Channel / QPSK

Transmitter Occupied Bandwidth (continued)

Results: 3 MHz Channel Bandwidth / 16QAM

Channel	Resource Block(s)	Resource Block Offset	Resolution Bandwidth (kHz)	Video Bandwidth (kHz)	Occupied Bandwidth (MHz)
Bottom	15	0	100	300	2.735
Middle	15	0	100	300	2.725
Top	15	0	100	300	2.755

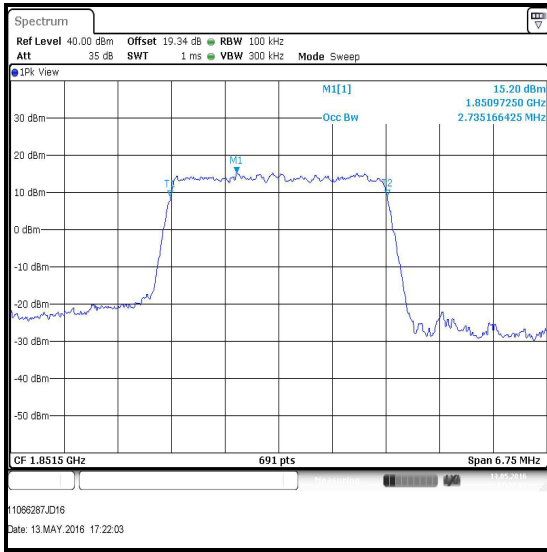

Bottom Channel / 16QAM

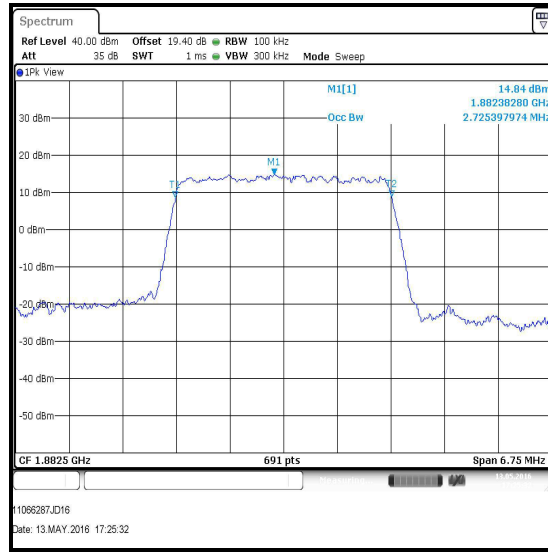

Middle Channel / 16QAM

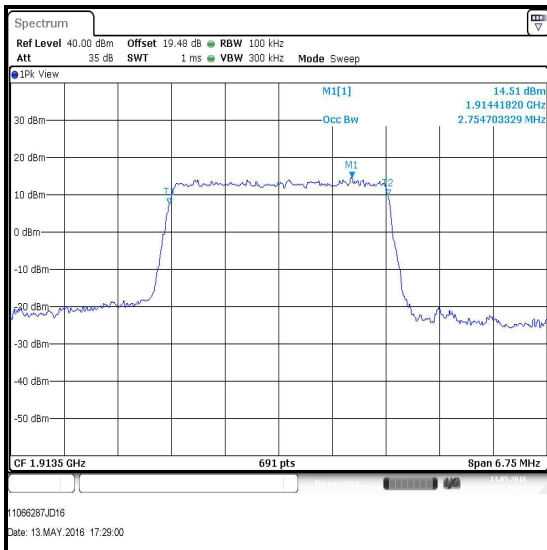

Top Channel / 16QAM

Transmitter Occupied Bandwidth (continued)

Results: 5 MHz Channel Bandwidth / QPSK

Channel	Resource Block(s)	Resource Block Offset	Resolution Bandwidth (kHz)	Video Bandwidth (kHz)	Occupied Bandwidth (MHz)
Bottom	25	0	100	300	4.526
Middle	25	0	100	300	4.526
Top	25	0	100	300	4.575

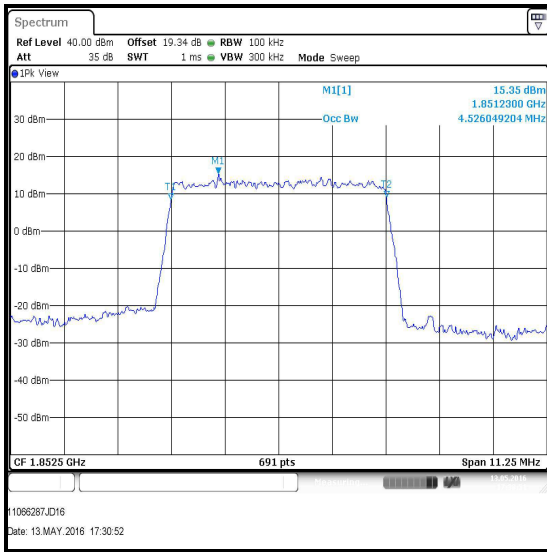

Bottom Channel / QPSK

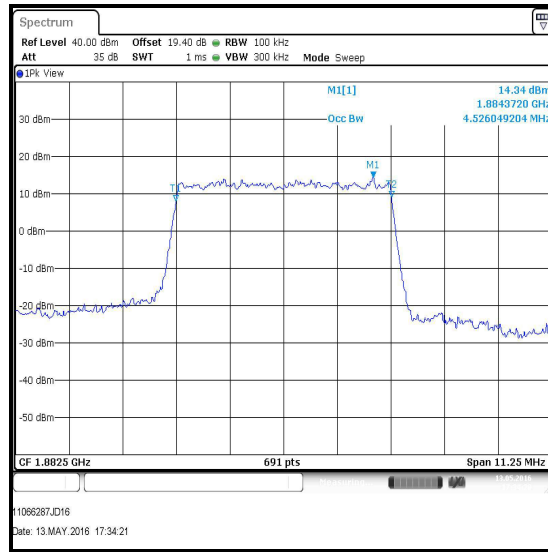

Middle Channel / QPSK

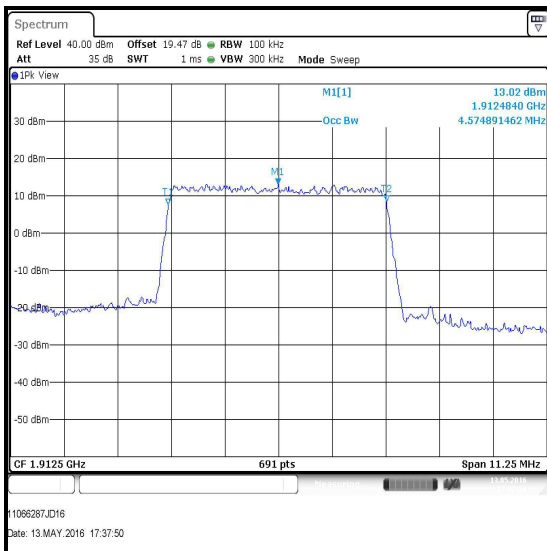

Top Channel / QPSK

Transmitter Occupied Bandwidth (continued)

Results: 5 MHz Channel Bandwidth / 16QAM

Channel	Resource Block(s)	Resource Block Offset	Resolution Bandwidth (kHz)	Video Bandwidth (kHz)	Occupied Bandwidth (MHz)
Bottom	25	0	100	300	4.510
Middle	25	0	100	300	4.493
Top	25	0	100	300	4.526

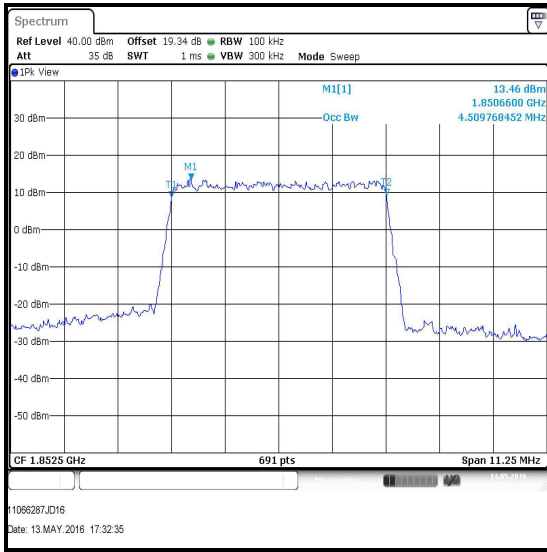

Bottom Channel / 16QAM



Middle Channel / 16QAM

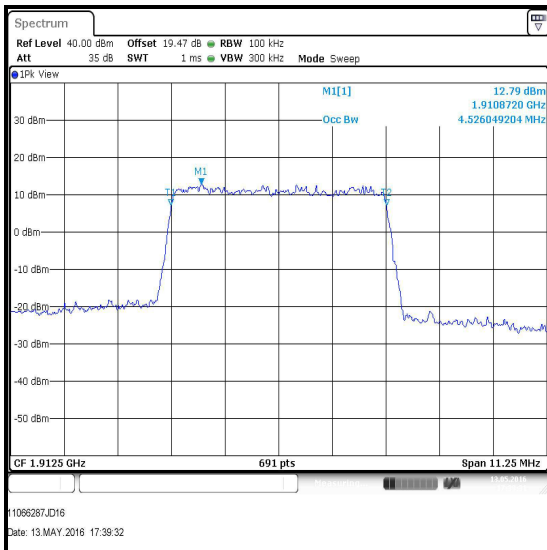

Top Channel / 16QAM

Transmitter Occupied Bandwidth (continued)

Results: 10 MHz Channel Bandwidth / QPSK

Channel	Resource Block(s)	Resource Block Offset	Resolution Bandwidth (kHz)	Video Bandwidth (kHz)	Occupied Bandwidth (MHz)
Bottom	50	0	200	1000	9.020
Middle	50	0	200	1000	8.987
Top	50	0	200	1000	9.020

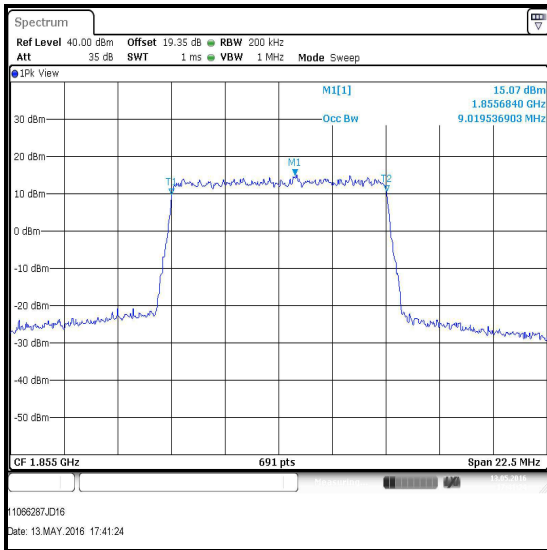

Bottom Channel / QPSK

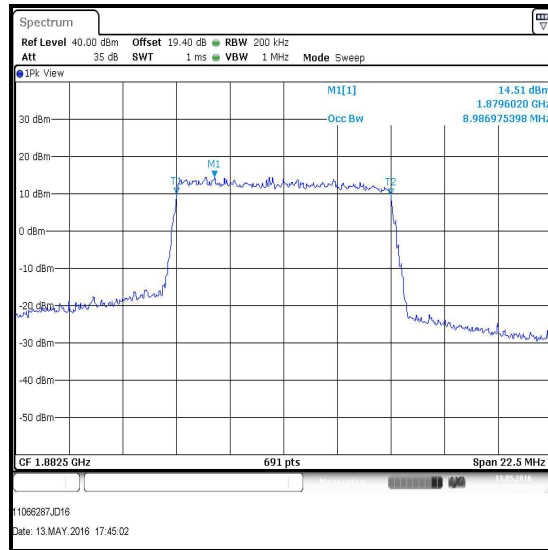

Middle Channel / QPSK

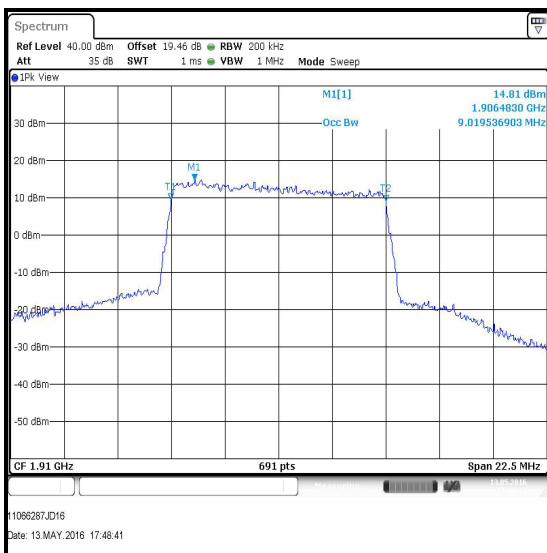

Top Channel / QPSK

Transmitter Occupied Bandwidth (continued)

Results: 10 MHz Channel Bandwidth / 16QAM

Channel	Resource Block(s)	Resource Block Offset	Resolution Bandwidth (kHz)	Video Bandwidth (kHz)	Occupied Bandwidth (MHz)
Bottom	50	0	200	1000	9.020
Middle	50	0	200	1000	9.020
Top	50	0	200	1000	9.020

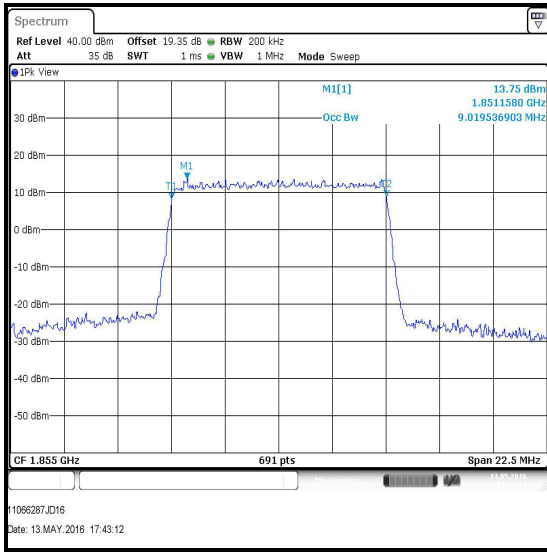

Bottom Channel / 16QAM

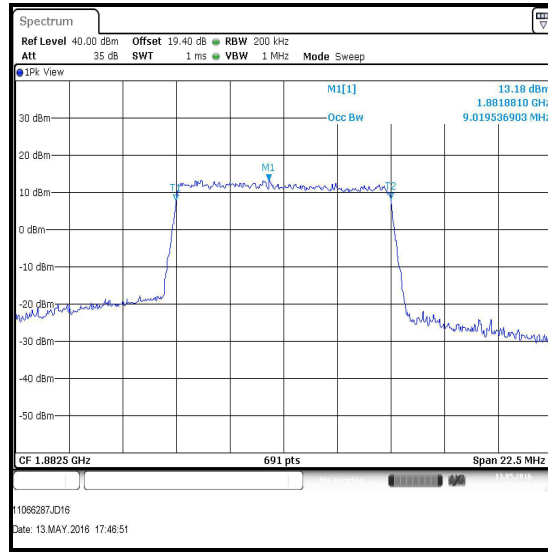

Middle Channel / 16QAM

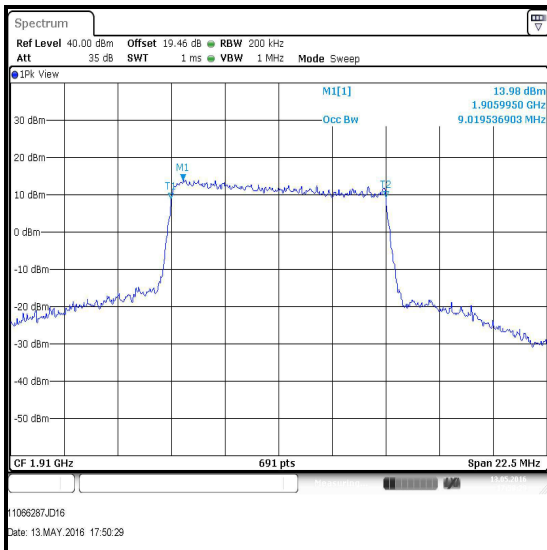

Top Channel / 16QAM

Transmitter Occupied Bandwidth (continued)

Results: 15 MHz Channel Bandwidth / QPSK

Channel	Resource Block(s)	Resource Block Offset	Resolution Bandwidth (kHz)	Video Bandwidth (kHz)	Occupied Bandwidth (MHz)
Bottom	75	0	300	1000	13.529
Middle	75	0	300	1000	13.480
Top	75	0	300	1000	13.529

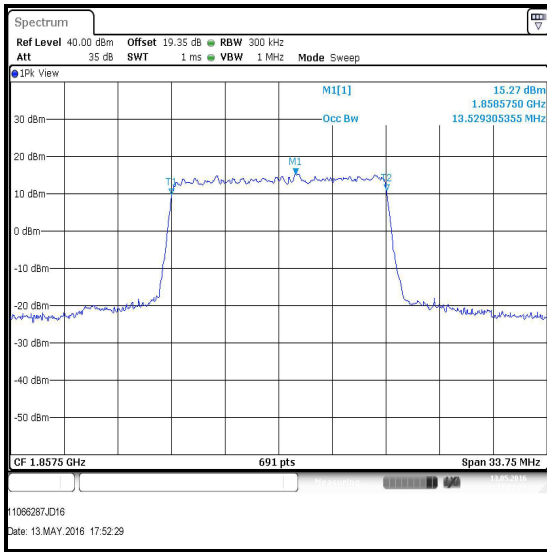

Bottom Channel / QPSK

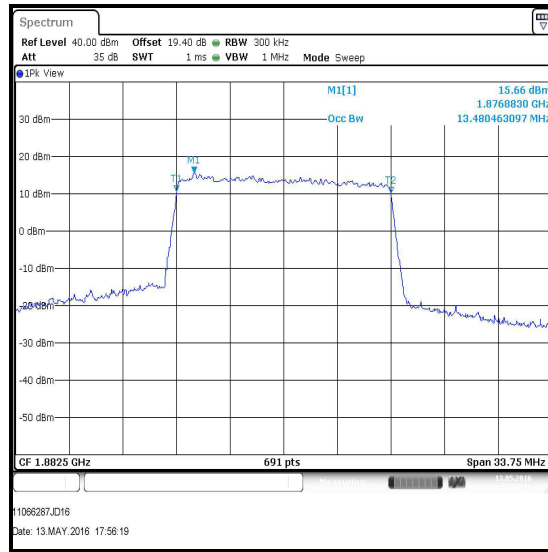

Middle Channel / QPSK

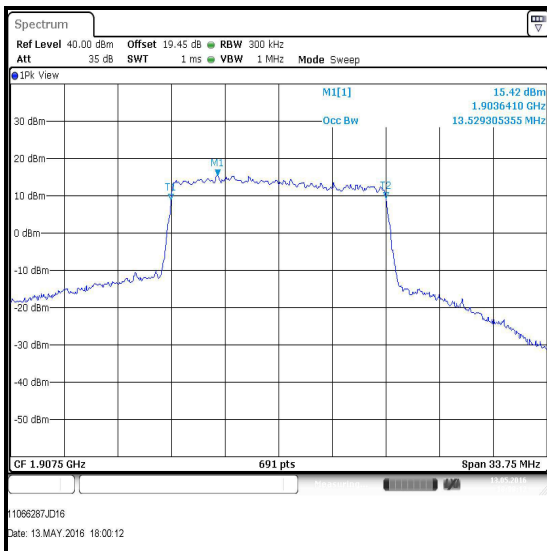

Top Channel / QPSK

Transmitter Occupied Bandwidth (continued)

Results: 15 MHz Channel Bandwidth / 16QAM

Channel	Resource Block(s)	Resource Block Offset	Resolution Bandwidth (kHz)	Video Bandwidth (kHz)	Occupied Bandwidth (MHz)
Bottom	75	0	300	1000	13.480
Middle	75	0	300	1000	13.529
Top	75	0	300	1000	13.529

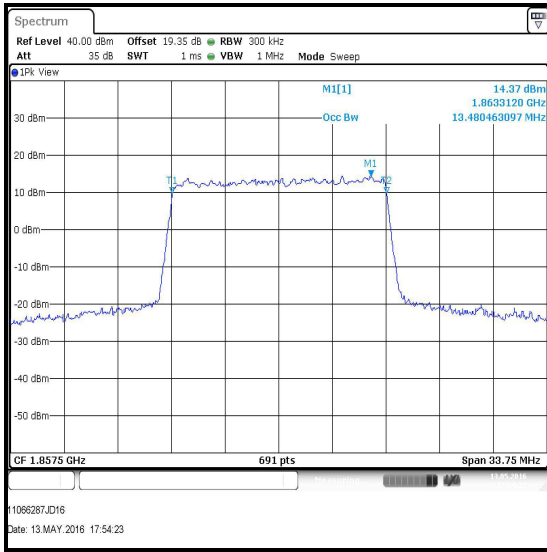

Bottom Channel / 16QAM

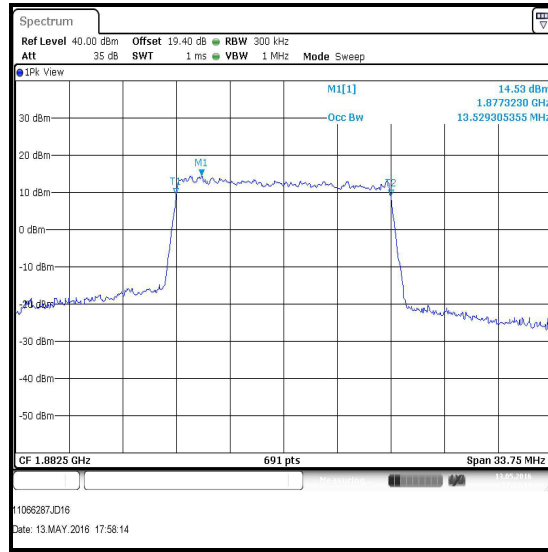

Middle Channel / 16QAM

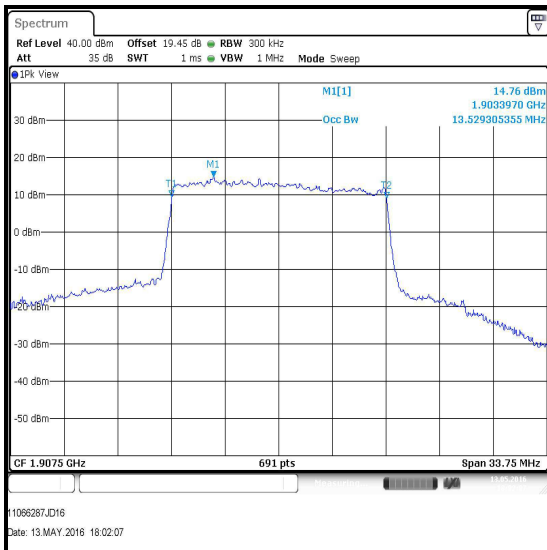

Top Channel / 16QAM

Transmitter Occupied Bandwidth (continued)

Results: 20 MHz Channel Bandwidth / QPSK

Channel	Resource Block(s)	Resource Block Offset	Resolution Bandwidth (kHz)	Video Bandwidth (kHz)	Occupied Bandwidth (MHz)
Bottom	100	0	500	2000	18.039
Middle	100	0	500	2000	18.039
Top	100	0	500	2000	18.039

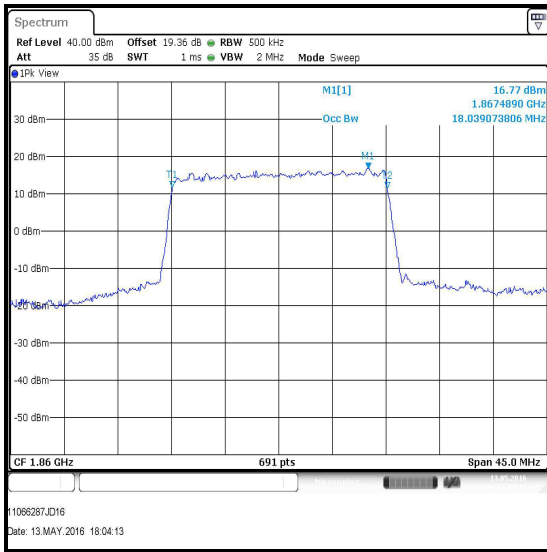

Bottom Channel / QPSK

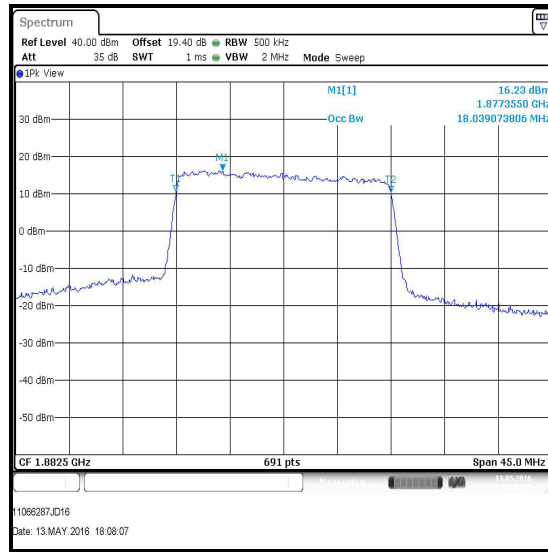

Middle Channel / QPSK

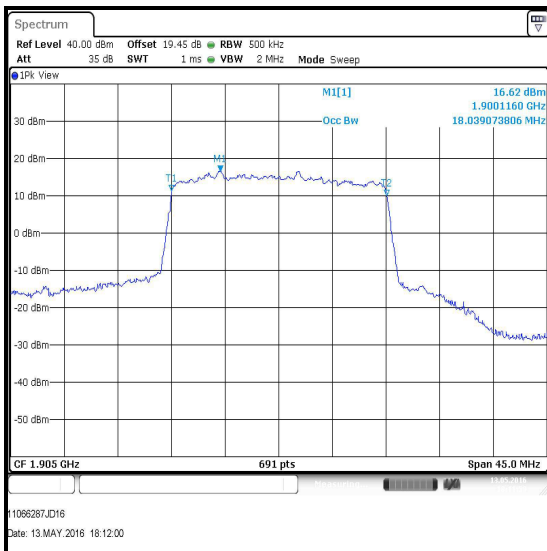

Top Channel / QPSK

Transmitter Occupied Bandwidth (continued)

Results: 20 MHz Channel Bandwidth / 16QAM

Channel	Resource Block(s)	Resource Block Offset	Resolution Bandwidth (kHz)	Video Bandwidth (kHz)	Occupied Bandwidth (MHz)
Bottom	100	0	500	2000	18.039
Middle	100	0	500	2000	18.039
Top	100	0	500	2000	17.974



Bottom Channel / 16QAM

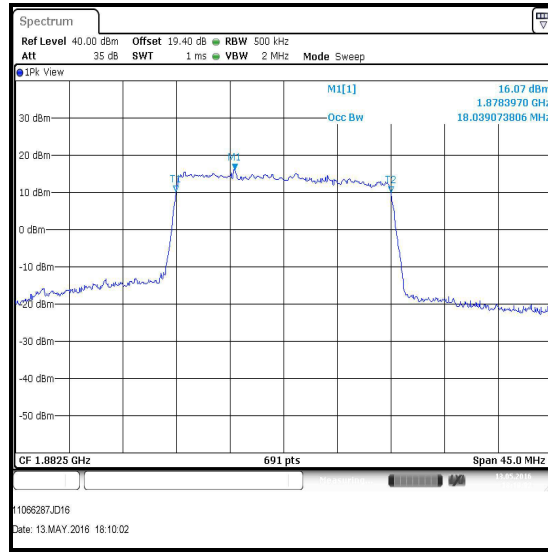

Middle Channel / 16QAM

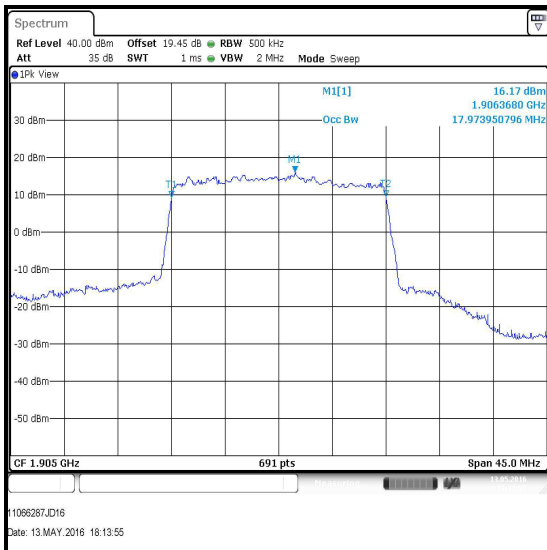

Top Channel / 16QAM

Transmitter Occupied Bandwidth (continued)**Test Equipment Used:**

Asset No.	Instrument	Manufacturer	Type No.	Serial No.	Date Calibration Due	Cal. Interval (Months)
M2002	Thermohygrometer	Testo	608-H1	45041825	02 Apr 2017	12
M1869	Wideband Radio Comms Tester	Rohde & Schwarz	CMW500	145923	05 Apr 2017	12
A2845	Attenuator	Radiall	R411.806.121	24325927	Calibrated before use	-
A2844	Attenuator	Radiall	R411.803.121	23404066	Calibrated before use	-
A2504	Directional Coupler	AtlanTecRF	CDC-003060-10	13122501839	Calibrated before use	-
S0577	Power Supply	TTi	CPX400S	436670	Calibrated before use	-
M1269	Multimeter	Fluke	179	90250210	26 May 2016	12
M1835	Signal Analyser	Rohde & Schwarz	FSV30	103050	26 Feb 2017	12

5.2.4. Transmitter Frequency Stability (Temperature Variation)

Test Summary:

Test Engineer:	Stefan Ho	Test Date:	05 May 2016
Test Sample IMEI:	357232070003189		

FCC Reference:	Parts 2.1055 & 24.235
Test Method Used:	KDB 971168 Section 9.0 referencing ANSI TIA-603-D-2010 Section 2.2.2 and FCC Part 2.1055

Environmental Conditions:

Ambient Temperature (°C):	23
Ambient Relative Humidity (%):	40

Note(s):

1. Flying leads were connected internally to the EUT in place of the battery. These leads extended and connected to a bench power supply at the nominal voltage of 3.9 V.
2. Frequency error was measured using a calibrated Rohde and Schwarz CMW 500 Universal Radio Communications Tester in accordance with current Rohde and Schwarz application notes. The EUT was connected by suitable RF cables to the CMW 500. A bi-directional communications link was established between the EUT and CMW 500. The frequency meter value was recorded.
3. Temperature was monitored throughout the test with a calibrated digital thermometer.

Test setup:

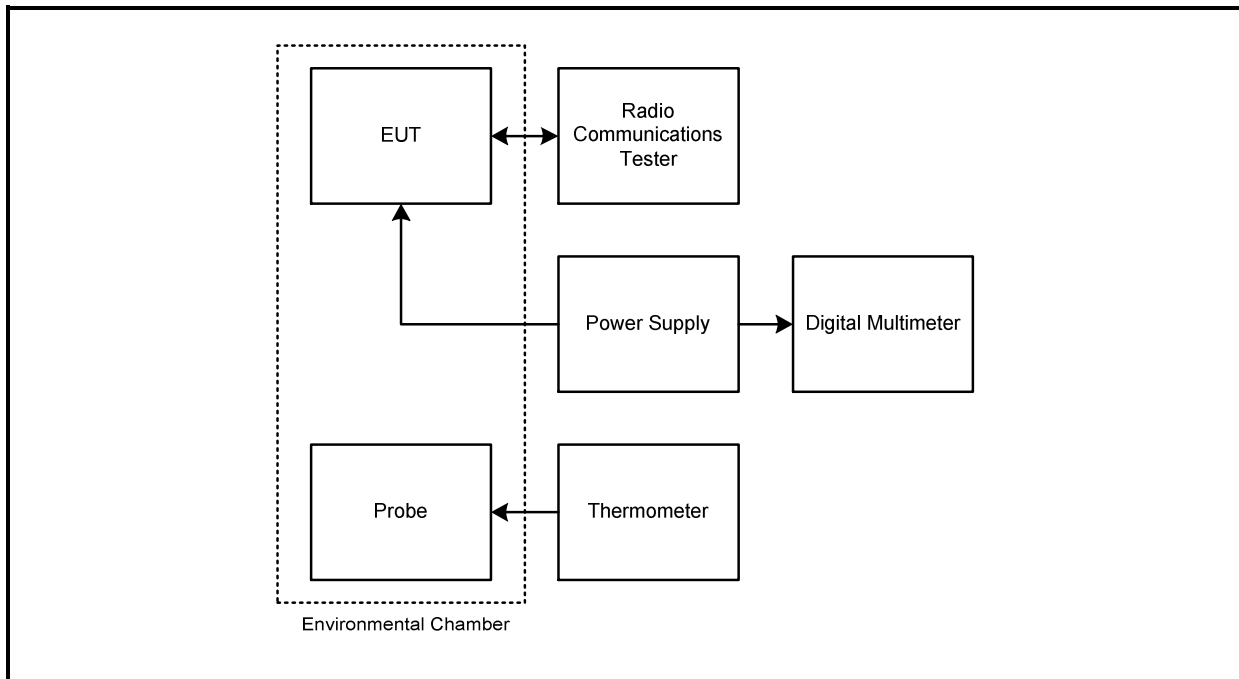

Transmitter Frequency Stability (Temperature Variation) (continued)**Results: Bottom Channel (1850.7 MHz)**

Temperature (°C)	Frequency Error (Hz)	Measured Frequency (MHz)	Lower Band Edge Limit (MHz)	Margin (MHz)	Result
-30	11	1850.699989	1850	0.699989	Complied
-20	8	1850.699992	1850	0.699992	Complied
-10	7	1850.699993	1850	0.699993	Complied
0	8	1850.699992	1850	0.699992	Complied
10	7	1850.699993	1850	0.699993	Complied
20	7	1850.699993	1850	0.699993	Complied
30	8	1850.699992	1850	0.699992	Complied
40	8	1850.699992	1850	0.699992	Complied
50	7	1850.699993	1850	0.699993	Complied

Results: Top Channel (1914.3 MHz)

Temperature (°C)	Frequency Error (Hz)	Measured Frequency (MHz)	Upper Band Edge Limit (MHz)	Margin (MHz)	Result
-30	9	1914.299991	1915	0.700009	Complied
-20	8	1914.299992	1915	0.700008	Complied
-10	8	1914.299992	1915	0.700008	Complied
0	7	1914.299993	1915	0.700007	Complied
10	9	1914.299991	1915	0.700009	Complied
20	8	1914.299992	1915	0.700008	Complied
30	10	1914.299990	1915	0.700010	Complied
40	9	1914.299991	1915	0.700009	Complied
50	9	1914.299991	1915	0.700009	Complied

Test Equipment Used:

Asset No.	Instrument	Manufacturer	Type No.	Serial No.	Date Calibration Due	Cal. Interval (Months)
M1659	Thermohygrometer	JM Handlungspunkt	30.5015.13	None stated	02 Apr 2017	12
M1869	Wideband Radio Comms Tester	Rohde & Schwarz	CMW 500	145923	05 Apr 2017	12
M1674	Environmental Chamber	Espec Corporation	SU-241	90213139	Calibrated before use	-
M1249	Thermometer	Fluke	52II	88800049	27 May 2016	12
S021	DC power supply	TTI	CPX200	061034	Calibrated before use	-
M1251	Multimeter	Fluke	175	89170179	13 May 2017	12

5.2.5. Transmitter Frequency Stability (Voltage Variation)**Test Summary:**

Test Engineer:	Stefan Ho	Test Date:	05 May 2016
Test Sample IMEI:	357232070003189		

FCC Reference:	Parts 2.1055 & 24.235
Test Method Used:	KDB 971168 Section 9.0 referencing ANSI/TIA-603-D-2010 Section 2.2.2 and FCC Part 2.1055

Environmental Conditions:

Temperature (°C):	23
Relative Humidity (%):	40

Note(s):

1. Flying leads were connected internally to the EUT in place of the battery. These leads extended and connected to a bench power supply.
2. Frequency error was measured using a calibrated Rohde and Schwarz CMW 500 Universal Radio Communications Tester in accordance with current Rohde and Schwarz application notes. The EUT was connected by suitable RF cables to the CMW 500. A bi-directional communications link was established between the EUT and CMW 500. The frequency meter value was recorded.
3. Voltage was monitored throughout the test with a calibrated digital voltmeter.

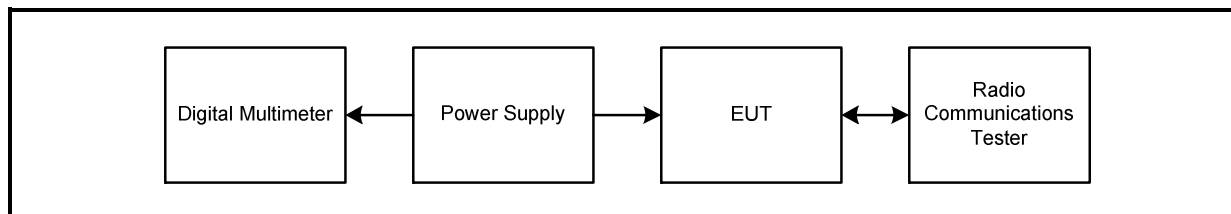
Test setup:

Transmitter Frequency Stability (Voltage Variation) (continued)**Results: Bottom Channel (1850.7 MHz)**

Supply Voltage (V)	Frequency Error (Hz)	Measured Frequency (MHz)	Lower Band Edge Limit (MHz)	Margin (MHz)	Result
3.5	7	1850.699993	1850	0.699993	Complied
4.4	8	1850.700008	1850	0.700008	Complied

Results: Top Channel (1914.3 MHz)

Supply Voltage (V)	Frequency Error (Hz)	Measured Frequency (MHz)	Upper Band Edge Limit (MHz)	Margin (MHz)	Result
3.5	9	1914.299991	1915	0.700009	Complied
4.4	12	1914.299988	1915	0.700012	Complied

Test Equipment Used:

Asset No.	Instrument	Manufacturer	Type No.	Serial No.	Date Calibration Due	Cal. Interval (Months)
M1659	Thermohygrometer	JM Handelpunkt	30.5015.13	None stated	02 Apr 2017	12
M1869	Wideband Radio Comms Tester	Rohde & Schwarz	CMW 500	145923	05 Apr 2017	12
S021	DC power supply	TTI	CPX200	061034	Calibrated before use	-
M1251	Multimeter	Fluke	175	89170179	13 May 2017	12

6. Measurement Uncertainty

No measurement or test can ever be perfect and the imperfections give rise to error of measurement in the results. Consequently the result of a measurement is only an approximation to the value of the measurand (the specific quantity subject to measurement) and is only complete when accompanied by a statement of the uncertainty of the approximation.

The expression of uncertainty of a measurement result allows realistic comparison of results with reference values and limits given in specifications and standards.

The uncertainty of the result may need to be taken into account when interpreting the measurement results.

The reported expanded uncertainties below are based on a standard uncertainty multiplied by an appropriate coverage factor such that a confidence level of approximately 95% is maintained. For the purposes of this document "approximately" is interpreted as meaning "effectively" or "for most practical purposes".

Measurement Type	Range	Confidence Level (%)	Calculated Uncertainty
Conducted Output Power	1850 to 1915 MHz	95%	±1.36 dB
Frequency Stability	1850 to 1915 MHz	95%	±23 Hz
Occupied Bandwidth	1850 to 1915 MHz	95%	±3.92 %

The methods used to calculate the above uncertainties are in line with those recommended within the various measurement specifications. Where measurement specifications do not include guidelines for the evaluation of measurement uncertainty the published guidance of the appropriate accreditation body is followed.

7. Report Revision History

Version Number	Revision Details		
	Page No(s)	Clause	Details
1.0	-	-	Initial Version

--- END OF REPORT ---