



TEST REPORT

Test Report No. : UL-RPT-RP11066287JD10A

Manufacturer : Flextronics International Sweden AB
Model No. : SR0020-W
FCC ID : 2AIP8I
Technology : GSM850
Test Standard(s) : FCC Parts 22.913(a)(2) & 22.355

1. This test report shall not be reproduced in full or partial, without the written approval of UL VS LTD.
2. The results in this report apply only to the sample(s) tested.
3. The sample tested is in compliance with the above standard(s).
4. The test results in this report are traceable to the national or international standards.
5. Version 1.0.

Date of Issue: 21 June 2016

Checked by:

Ian Watch
Senior Engineer, Radio Laboratory

Company Signatory:

pp

Steven White
Service Lead, Radio Laboratory,
UL VS LTD



This laboratory is accredited by UKAS.
The tests reported herein have been
performed in accordance with its terms
of accreditation.

UL VS LTD

Pavilion A, Ashwood Park, Ashwood Way, Basingstoke, Hampshire, RG23 8BG, UK
Telephone: +44 (0)1256 312000
Facsimile: +44 (0)1256 312001

This page has been left intentionally blank.

Table of Contents

1. Customer Information / Manufacturer Information	4
1.1. Customer Information	4
1.2. Manufacturer Information	4
2. Summary of Testing.....	5
2.1. General Information	5
2.2. Summary of Test Results	5
2.3. Methods and Procedures	5
2.4. Deviations from the Test Specification	5
3. Equipment Under Test (EUT)	6
3.1. Identification of Equipment Under Test (EUT)	6
3.2. Description of EUT	6
3.3. Modifications Incorporated in the EUT	6
3.4. Additional Information Related to Testing	7
3.5. Support Equipment	7
4. Operation and Monitoring of the EUT during Testing	8
4.1. Operating Modes	8
4.2. Configuration and Peripherals	8
5. Measurements, Examinations and Derived Results.....	9
5.1. General Comments	9
5.2. Test Results	10
5.2.1. Transmitter Output Power (ERP)	10
5.2.2. Transmitter Frequency Stability (Temperature Variation)	12
5.2.3. Transmitter Frequency Stability (Voltage Variation)	14
5.2.4. Transmitter Occupied Bandwidth	15
6. Measurement Uncertainty	20
7. Report Revision History	21

1. Customer Information / Manufacturer Information

1.1. Customer Information

Company Name:	Sirin Labs AG
Address:	Muhlentalstrasse 2 8200 Schaffhausen Switzerland

1.2. Manufacturer Information





Manufacturer Name:	Flextronics International Sweden AB
Address:	Datalinjen 3A SE – 583 30 Linköping Sweden

2. Summary of Testing

2.1. General Information

Specification Reference:	47CFR22
Specification Title:	Code of Federal Regulations Volume 47 (Telecommunications): Part 22 Subpart H (Public Mobile Services)
Site Registration:	209735
Location of Testing:	UL VS LTD, Unit 3 Horizon, Wade Road, Kingsland Business Park, Basingstoke, Hampshire, RG24 8AH, United Kingdom
Test Dates:	06 May 2016 to 16 May 2016

2.2. Summary of Test Results

FCC Reference (47CFR)	Measurement	Result
Part 22.913(a)(2)	Transmitter Output Power (ERP)	
Part 2.1055/22.355	Transmitter Frequency Stability (Temperature and Voltage Variation)	
Part 2.1049	Transmitter Occupied Bandwidth	
Key to Results		
 = Complied  = Did not comply		

2.3. Methods and Procedures

Reference:	ANSI/TIA-603-D-2010
Title:	Land Mobile Communications Equipment, Measurements and performance Standards
Reference:	FCC KDB 971168 D01 v02r02, October 17 2014
Title:	Measurement Guidance for Certification of Licensed Digital Transmitters

2.4. Deviations from the Test Specification

For the measurements contained within this test report, there were no deviations from, additions to, or exclusions from the test specification identified above.

3. Equipment Under Test (EUT)

3.1. Identification of Equipment Under Test (EUT)

Brand Name:	SOLARIN
Model Number:	SR0020-W
Test Sample Serial Number:	0108 (<i>Conducted Sample #2</i>)
Test Sample IMEI:	357232070003189
Hardware Version:	TP1
Software Version:	LRC1TA.1.0.2.3
Handset Cover Material:	Technical leather with titanium coating
FCC ID:	2AIP8I

3.2. Description of EUT

The equipment under test was a Mobile device supporting Cellular, WLAN, BT, BTLE, RFID & GPS technologies.

3.3. Modifications Incorporated in the EUT

No modifications were applied to the EUT during testing.

3.4. Additional Information Related to Testing

Technology Tested:	GSM850		
Type of Radio Device:	Transceiver		
Mode:	GSM/GPRS/EGPRS		
Modulation Type:	GMSK / 8PSK		
Channel Spacing:	200 kHz		
Power Supply Requirement(s):	Nominal	3.9 V	
	Minimum	3.5 V	
	Maximum	4.4 V	
Maximum Output Power (ERP):	GSM	27.4 dBm	
	GPRS	27.4 dBm	
	EGPRS	24.9 dBm	
Transmit Frequency Range:	824 to 849 MHz		
Transmit Channels Tested:	Channel ID	Channel Number	Channel Frequency (MHz)
	Bottom	128	824.2
	Middle	190	836.6
	Top	251	848.8

3.5. Support Equipment

No support equipment was used to exercise the EUT during testing.

4. Operation and Monitoring of the EUT during Testing

4.1. Operating Modes

The EUT was tested in the following operating mode(s):

- Constantly transmitting at full power on bottom, middle and top channels as required.
- Occupied bandwidth, ERP and band edge tests were performed with the EUT in GSM single timeslot circuit switched and GPRS/EGPRS Multislot Class 33 with the unit transmitting on one timeslot in the uplink. The EUT output power was initially checked when transmitting at maximum power on one, two, three and four timeslots. The highest power was observed when transmitting on one timeslot.
- EGPRS tests were performed with the EUT using MCS5 (8PSK modulation).
- Transmitter radiated spurious emissions were checked in all modes during pre-scans. Circuit switched voice was found to be the worst case and all final measurements were performed with the EUT in this mode.

4.2. Configuration and Peripherals

The EUT was tested in the following configuration(s):

- The EUT was connected to a Rohde and Schwarz CMW500 GSM/GPRS/EGPRS system simulator, operating in a transceiver mode.
- Conducted measurements were performed using a conducted sample supplied by the customer. Short 4-wire DC flying leads were connected internally to the device in place of the battery, and exiting through a hole in the casing. These leads were then extended through a connector interface to a laboratory DC power supply.
- For conducted measurements, the EUT RF conducted port was a temporary SMA connector that was connected internally in place of the PCB antenna. The loss of the internal connection to the connector was accounted for in calculations.
- For the conducted tests in this report, the antenna port measured was identified by the manufacturer as Antenna #2.

5. Measurements, Examinations and Derived Results

5.1. General Comments

Measurement uncertainties are evaluated in accordance with current best practice. Our reported expanded uncertainties are based on standard uncertainties, which are multiplied by an appropriate coverage factor to provide a statistical confidence level of approximately 95%. Please refer to *Section 6. Measurement Uncertainty* for details.

In accordance with UKAS requirements all the measurement equipment is on a calibration schedule. All equipment was within the calibration period on the date of testing.

5.2. Test Results

5.2.1. Transmitter Output Power (ERP)

Test Summary:

Test Engineer:	David Doyle	Test Date:	16 May 2016
Test Sample IMEI:	357232070003189		

FCC Reference:	Part 22.913(a)(2)
Test Method Used:	KDB 971168 Section 5.1.1

Environmental Conditions:

Temperature (°C):	24
Relative Humidity (%):	34

Note(s):

- The signal analyser was connected to the RF port on the EUT via the coupled port on an RF combiner using suitable attenuation and RF cables. An RF level offset was entered on the signal analyser to compensate for the loss of the combiner, attenuators and RF cables. The through port on the RF coupler was connected to an R&S CMW 500 Radio Communications Tester.
- The customer stated a maximum antenna gain of -2.96 dBi. As the limit is an E.R.P. limit, the gain in dBi has been converted to dBd. The gain in dBd was calculated as:

$$-2.96 \text{ dBi} - 2.15 \text{ dB} = -5.1 \text{ dBd.}$$

- The antenna gain was added to the conducted output power to obtain the ERP.

Test setup:

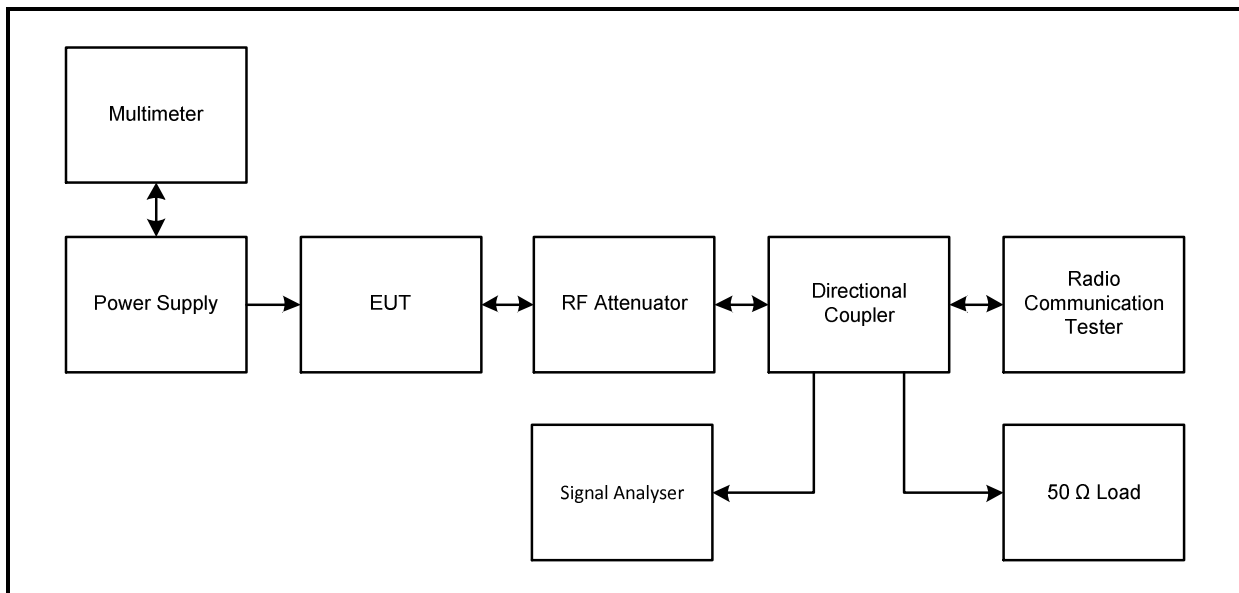

Transmitter Output Power (ERP) (continued)**Results: GSM Circuit Switched**

Channel	Frequency (MHz)	Conducted Output Power (dBm)	Antenna Gain (dBd)	ERP (dBm)	ERP Limit (dBm)	Margin (dB)	Result
Bottom	824.2	32.5	-5.1	27.4	38.45	11.05	Complied
Middle	836.6	32.4	-5.1	27.3	38.45	11.15	Complied
Top	848.8	32.3	-5.1	27.2	38.45	11.25	Complied

Results: GPRS

Channel	Frequency (MHz)	Conducted Output Power (dBm)	Antenna Gain (dBd)	ERP (dBm)	ERP Limit (dBm)	Margin (dB)	Result
Bottom	824.2	32.5	-5.1	27.4	38.45	11.05	Complied
Middle	836.6	32.5	-5.1	27.4	38.45	11.05	Complied
Top	848.8	32.4	-5.1	27.3	38.45	11.15	Complied

Results: EGPRS / MCS5

Channel	Frequency (MHz)	Conducted Output Power (dBm)	Antenna Gain (dBd)	ERP (dBm)	ERP Limit (dBm)	Margin (dB)	Result
Bottom	824.2	29.8	-5.1	24.7	38.45	13.75	Complied
Middle	836.6	30.0	-5.1	24.9	38.45	13.55	Complied
Top	848.8	30.0	-5.1	24.9	38.45	13.55	Complied

Test Equipment Used:

Asset No.	Instrument	Manufacturer	Type No.	Serial No.	Date Calibration Due	Cal. Interval (Months)
M2002	Thermohygrometer	Testo	608-H1	45041825	02 Apr 2017	12
A2504	Directional Coupler	AtlanTecRF	CDC-003060-10	13122501839	Calibrated before use	-
A2845	Attenuator	Radiall	R411.806.121	24325927	Calibrated before use	-
A2844	Attenuator	Radiall	R411.806.121	23404066	Calibrated before use	-
M1835	Signal Analyser	Rohde & Schwarz	FSV30	103050	26 Feb 2017	12
M1269	Multimeter	Fluke	179	90250210	13 May 2017	12
S0577	DC Power Supply	TTi	CPX400S	436670	Calibrated before use	-
M199	Power Meter	Rohde & Schwarz	NRVS	827023/075	11 Apr 2018	24
M1267	Thermal Power Sensor	Rohde & Schwarz	NRV-Z52	100155	15 Apr 2018	24
M1802	Signal Generator	Rohde & Schwarz	SMU200A	103607	16 Feb 2018	24

5.2.2. Transmitter Frequency Stability (Temperature Variation)**Test Summary:**

Test Engineer:	Stefan Ho	Test Date:	09 May 2016
Test Sample IMEI:	357232070003189		

FCC Reference:	Parts 2.1055 & 22.355
Test Method Used:	KDB 971168 Section 9.0, ANSI TIA-603-D Section 2.2.2 and FCC Part 2.1055
Test Mode:	Voice

Environmental Conditions:

Ambient Temperature (°C):	24
Ambient Relative Humidity (%):	35

Note(s):

1. A dummy battery was placed on the EUT and the dummy battery cables connected to a bench power supply set to the nominal battery voltage of 3.9 V.
2. Frequency error was measured using a calibrated Rohde & Schwarz CMW 500 Universal Radio Communications Tester in accordance with current Rohde & Schwarz application notes. The EUT was connected by suitable RF cables to the CMW 500. A bi-directional communications link was established between the EUT and CMW 500. The frequency meter value was recorded.
3. Temperature was monitored throughout the test with a calibrated digital thermometer.

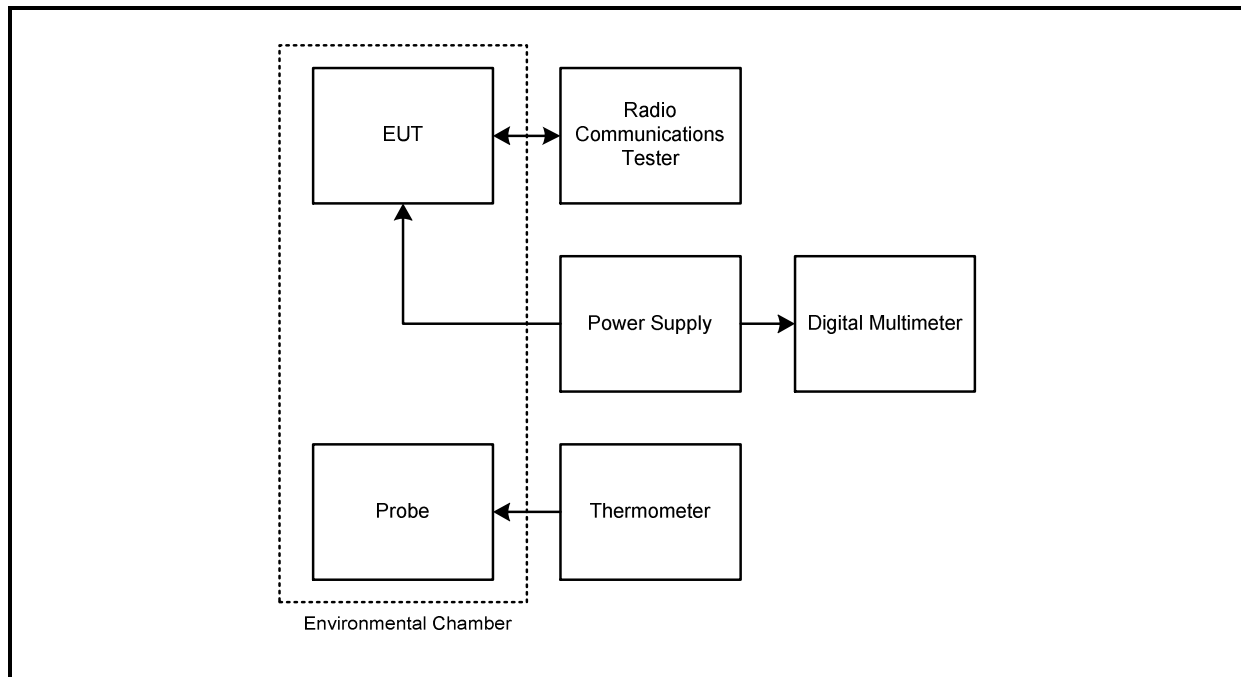
Test setup:

Transmitter Frequency Stability (Temperature Variation) (continued)**Results: Middle Channel (836.6 MHz)**

Temperature (°C)	Measured Frequency (MHz)	Frequency Error (Hz)	Frequency Error (ppm)	Limit (ppm)	Margin (ppm)	Result
-30	836.600011	11	0.0131	2.5	2.4869	Complied
-20	836.600013	13	0.0155	2.5	2.4845	Complied
-10	836.600017	17	0.0203	2.5	2.4797	Complied
0	836.600017	17	0.0203	2.5	2.4797	Complied
10	836.600016	16	0.0191	2.5	2.4809	Complied
20	836.600016	16	0.0191	2.5	2.4809	Complied
30	836.600016	16	0.0191	2.5	2.4809	Complied
40	836.600014	14	0.0167	2.5	2.4833	Complied
50	836.600009	9	0.0108	2.5	2.4882	Complied

Test Equipment Used:

Asset No.	Instrument	Manufacturer	Type No.	Serial No.	Date Calibration Due	Cal. Interval (Months)
M1659	Thermohygrometer	JM Handelpunkt	30.5015.13	None stated	02 Apr 2017	12
M1859	Wideband Radio Comms Tester	Rohde & Schwarz	CMW500	145920	12 Jun 2016	12
M1674	Environmental Chamber	Espec Corporation	SU-241	92013139	Calibrated before use	-
M1249	Thermometer	Fluke	52II	88800049	27 May 2016	12
S021	Dual DC power supply	Thurlby Thandar Instruments	CPX200	061034	Calibrated before use	-
M1229	Multimeter	Fluke	179	87640015	21 Apr 2017	12

5.2.3. Transmitter Frequency Stability (Voltage Variation)**Test Summary:**

Test Engineer:	Stefan Ho	Test Date:	06 May 2016
Test Sample IMEI:	357232070003189		

FCC Reference:	Parts 2.1055 & 22.355
Test Method Used:	KDB 971168 Section 9.0, ANSI TIA-603-D Section 2.2.2 and FCC Part 2.1055
Test Mode:	Voice

Environmental Conditions:

Temperature (°C):	20
Relative Humidity (%):	33

Note(s):

1. A dummy battery was placed on the EUT and the dummy battery cables connected to a bench power supply set to the nominal battery voltage of 3.9 V.
2. Frequency error was measured using a calibrated Rohde & Schwarz CMW 500 Universal Radio Communications Tester in accordance with current Rohde & Schwarz application notes. The EUT was connected by suitable RF cables to the CMW 500. A bi-directional communications link was established between the EUT and CMW 500. The frequency meter value was recorded.
3. Voltage was monitored throughout the test with a calibrated digital voltmeter.

Results: Middle Channel (836.6 MHz)

Supply Voltage (V)	Measured Frequency (MHz)	Frequency Error (Hz)	Frequency Error (ppm)	Limit (ppm)	Margin (ppm)	Result
3.5	836.600013	13	0.0155	2.5	2.4845	Complied
4.4	836.600016	16	0.0191	2.5	2.4809	Complied

Test Equipment Used:

Asset No.	Instrument	Manufacturer	Type No.	Serial No.	Date Calibration Due	Cal. Interval (Months)
M1659	Thermohygrometer	JM Handelpunkt	30.5015.13	None stated	02 Apr 2017	12
M1859	Wideband Radio Comms Tester	Rohde & Schwarz	CMW500	145920	12 Jun 2016	12
S021	Dual DC power supply	Thurlby Thandar Instruments	CPX200	061034	Calibrated before use	-
M1251	Multimeter	Fluke	175	89170179	26 May 2016	12

5.2.4. Transmitter Occupied Bandwidth

Test Summary:

Test Engineer:	David Doyle	Test Date:	16 May 2016
Test Sample IMEI:	357232070003189		

FCC Reference:	Part 2.1049
Test Method Used:	KDB 971168 D01 Section 4.2

Environmental Conditions:

Temperature (°C):	24
Relative Humidity (%):	34

Note(s):

1. Occupied bandwidth (99% bandwidth) was measured using a signal analyser occupied bandwidth function.
2. The signal analyser was connected to the RF port on the EUT via the coupled port on an RF combiner using suitable attenuation and RF cables. An RF level offset was entered on the signal analyser to compensate for the loss of the combiner, attenuators and RF cables. The through port on the RF coupler was connected to an R&S CMW 500 Radio Communications Tester.

Test setup:

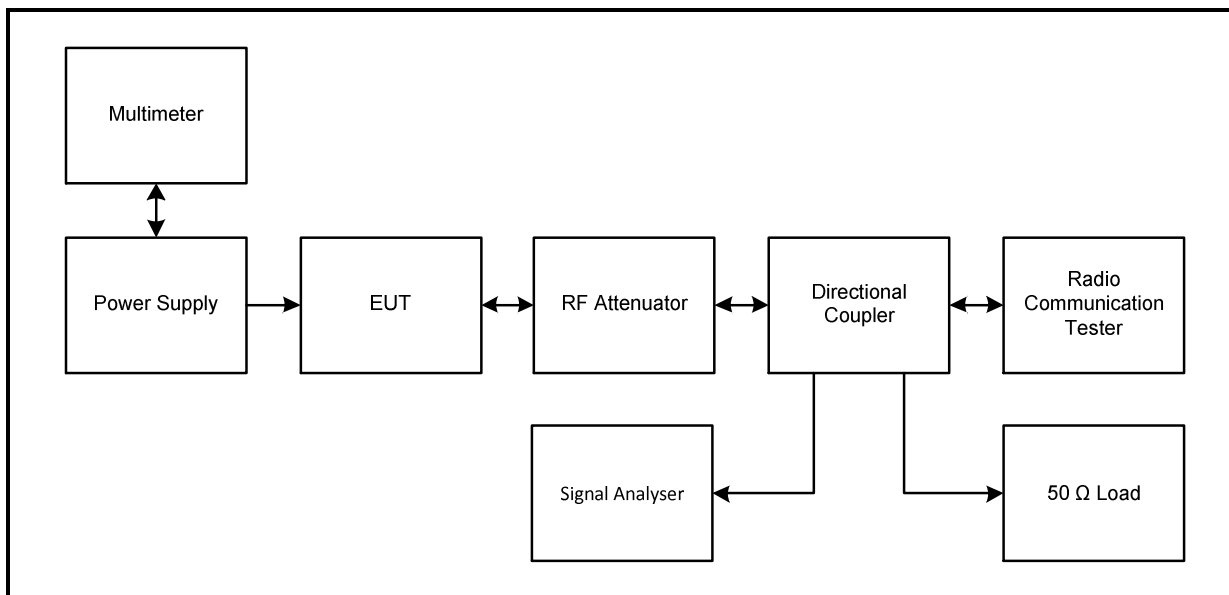

Transmitter Occupied Bandwidth (continued)

Results: GSM Circuit Switched

Channel	Frequency (MHz)	Occupied Bandwidth (kHz)
Bottom	824.2	245.731
Middle	836.6	243.994
Top	848.8	245.731

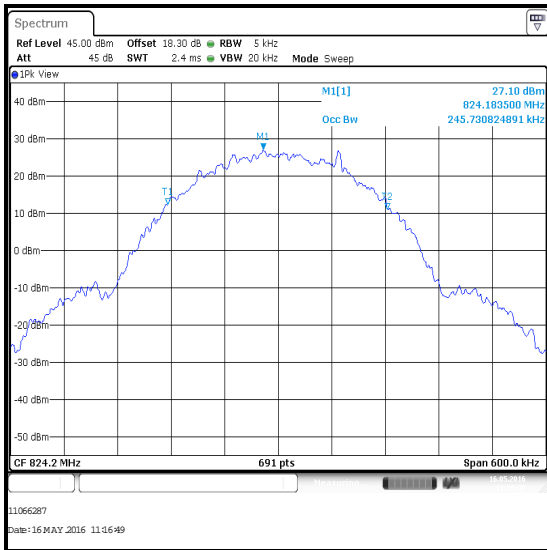

Bottom Channel

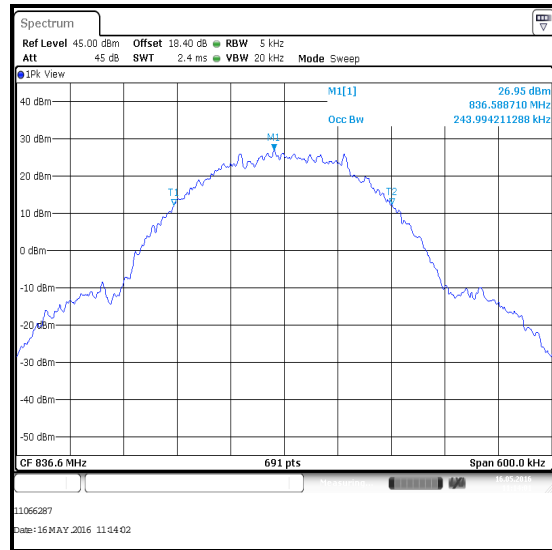

Middle Channel

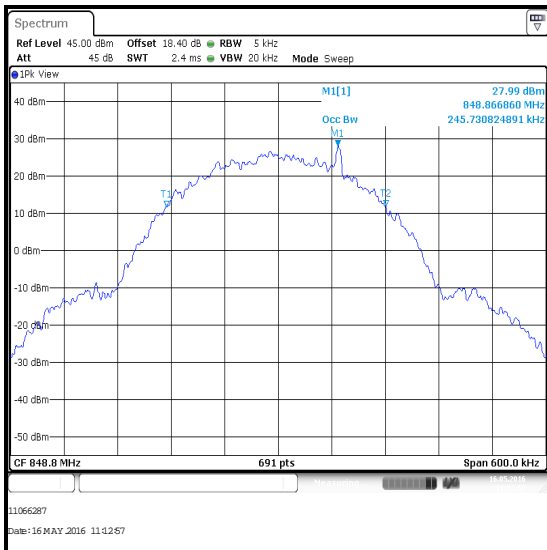

Top Channel

Transmitter Occupied Bandwidth (continued)

Results: GPRS

Channel	Frequency (MHz)	Occupied Bandwidth (kHz)
Bottom	824.2	244.863
Middle	836.6	242.258
Top	848.8	244.863

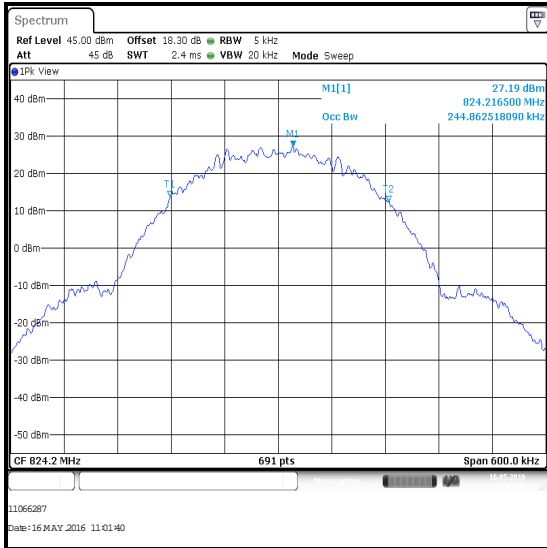

Bottom Channel

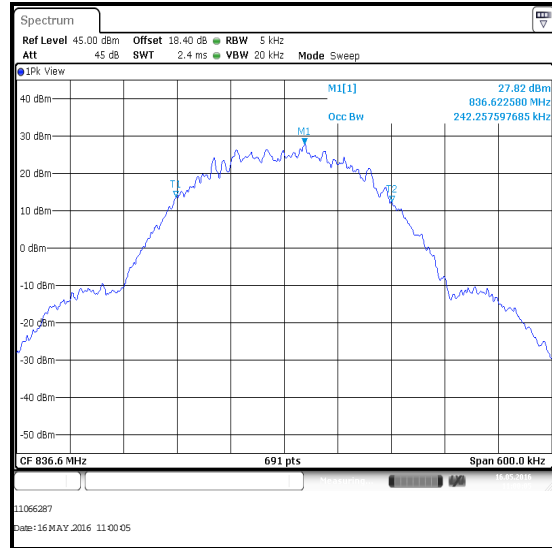

Middle Channel

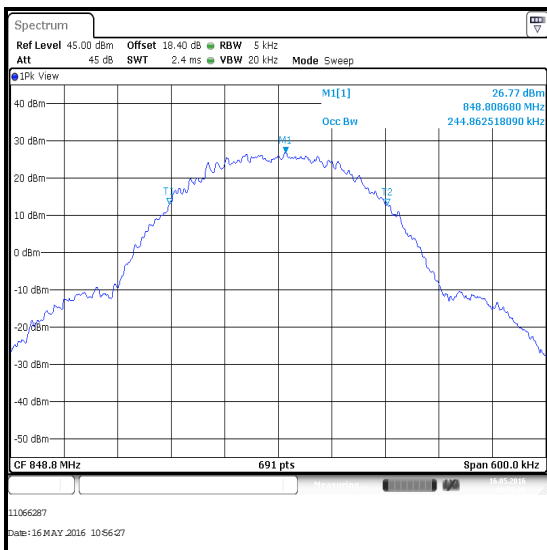

Top Channel

Transmitter Occupied Bandwidth (continued)

Results: EGPRS / MCS5

Channel	Frequency (MHz)	Occupied Bandwidth (kHz)
Bottom	824.2	249.204
Middle	836.6	245.731
Top	848.8	248.336

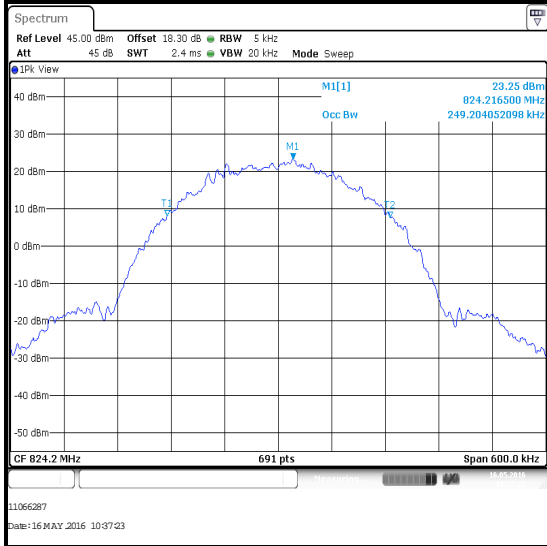

Bottom Channel

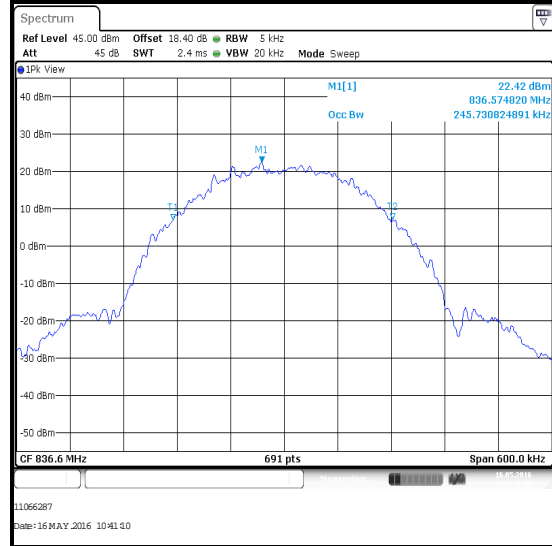

Middle Channel

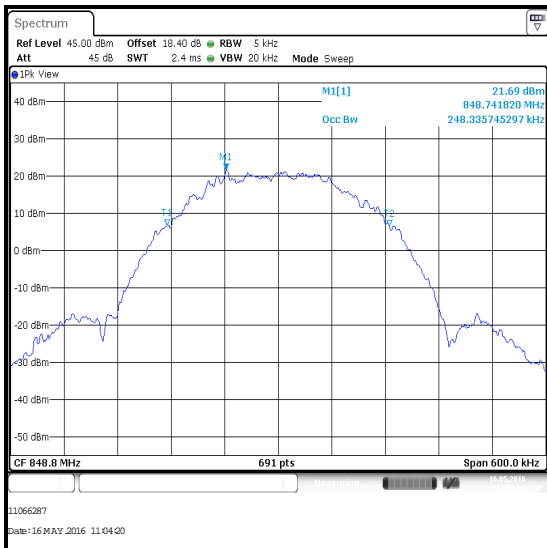

Top Channel

Transmitter Occupied Bandwidth (continued)**Test Equipment Used:**

Asset No.	Instrument	Manufacturer	Type No.	Serial No.	Date Calibration Due	Cal. Interval (Months)
M2002	Thermohygrometer	Testo	608-H1	45041825	02 Apr 2017	12
A2504	Directional Coupler	AtlanTecRF	CDC-003060-10	13122501839	Calibrated before use	-
A2845	Attenuator	Radiall	R411.806.121	24325927	Calibrated before use	-
A2844	Attenuator	Radiall	R411.806.121	23404066	Calibrated before use	-
M1835	Signal Analyser	Rohde & Schwarz	FSV30	103050	26 Feb 2017	12
M1269	Multimeter	Fluke	179	90250210	13 May 2017	12
S0577	DC Power Supply	TTi	CPX400S	436670	Calibrated before use	-
M199	Power Meter	Rohde & Schwarz	NRVS	827023/075	11 Apr 2018	24
M1267	Thermal Power Sensor	Rohde & Schwarz	NRV-Z52	100155	15 Apr 2018	24
M1802	Signal Generator	Rohde & Schwarz	SMU200A	103607	16 Feb 2018	24

6. Measurement Uncertainty

No measurement or test can ever be perfect and the imperfections give rise to error of measurement in the results. Consequently the result of a measurement is only an approximation to the value of the measurand (the specific quantity subject to measurement) and is only complete when accompanied by a statement of the uncertainty of the approximation.

The expression of uncertainty of a measurement result allows realistic comparison of results with reference values and limits given in specifications and standards.

The uncertainty of the result may need to be taken into account when interpreting the measurement results.

The reported expanded uncertainties below are based on a standard uncertainty multiplied by an appropriate coverage factor such that a confidence level of approximately 95% is maintained. For the purposes of this document "approximately" is interpreted as meaning "effectively" or "for most practical purposes".

Measurement Type	Range	Confidence Level (%)	Calculated Uncertainty
Conducted Output Power	824 to 849 MHz	95%	±1.13 dB
Frequency Stability	824 to 849 MHz	95%	±23 Hz
Occupied Bandwidth	824 to 849 MHz	95%	±3.92 %

The methods used to calculate the above uncertainties are in line with those recommended within the various measurement specifications. Where measurement specifications do not include guidelines for the evaluation of measurement uncertainty the published guidance of the appropriate accreditation body is followed.

7. Report Revision History

Version Number	Revision Details		
	Page No(s)	Clause	Details
1.0	-	-	Initial Version

--- END OF REPORT ---