



# TEST REPORT

**Test Report No. :** UL-RPT-RP11066287JD09C

**Manufacturer** : Flextronics International Sweden AB  
**PMN** : SOLARIN  
**Model Name/HVIN** : SR0020-W  
**FCC ID** : 2AIP8I  
**ISED Certification No.** : IC: 21579-I  
**Technology** : WLAN  
**Test Standard(s)** : FCC Part 15.407(h)(2)(iii) & (h)(2)(iv) and  
ISED Canada RSS-247 6.3 2)(iii), 6.3 2)(iv) & 6.3 2)(v)

1. This test report shall not be reproduced in full or partial, without the written approval of UL VS LTD.
2. The results in this report apply only to the sample(s) tested.
3. The sample tested is in compliance with the above standard(s).
4. The test results in this report are traceable to the national or international standards.
5. Version 1.0

**Date of Issue:** 19 September 2016

**Checked by:**

Sarah Williams  
Engineer, Radio Laboratory

**Company Signatory:**

Steven White  
Service Lead, Radio Laboratory  
UL VS LTD



This laboratory is accredited by UKAS.  
The tests reported herein have been  
performed in accordance with its terms  
of accreditation.

---

## UL VS LTD

Pavilion A, Ashwood Park, Ashwood Way, Basingstoke, Hampshire, RG23 8BG, UK  
Telephone: +44 (0)1256 312000  
Facsimile: +44 (0)1256 312001

This page has been left intentionally blank.

## **Table of Contents**

<b>1. Customer Information.....</b>	<b>4</b>
1.1. Customer Information	4
1.2. Manufacturer Information	4
<b>2. Summary of Testing.....</b>	<b>5</b>
2.1. General Information	5
2.2. Summary of Test Results	5
2.3. Methods and Procedures	5
2.4. Deviations from the Test Specification	5
<b>3. Equipment Under Test (EUT) .....</b>	<b>6</b>
3.1. Identification of Equipment Under Test (EUT)	6
3.2. Description of EUT	6
3.3. Modifications Incorporated in the EUT	6
3.4. Additional Information Related to Testing	6
3.5. Support Equipment	7
<b>4. Operation and Monitoring of the EUT during Testing .....</b>	<b>8</b>
4.1. Operating Modes	8
4.2. Configuration and Peripherals	8
<b>5. Measurements, Examinations and Derived Results.....</b>	<b>12</b>
5.1. General Comments	12
5.2. Test Results	13
5.2.1. Channel Closing Transmission Time and Channel Move Time	13
5.2.2. Non-Occupancy Period	16
<b>6. Measurement Uncertainty .....</b>	<b>19</b>
<b>7. Report Revision History .....</b>	<b>20</b>
<b>Appendix 1. Radar Calibration .....</b>	<b>21</b>
<b>Appendix 2. Aeroflex Test Platform Approval email.....</b>	<b>23</b>
<b>Appendix 3. System Noise Floor Reference Plots.....</b>	<b>24</b>
<b>Appendix 4. Channel Loading.....</b>	<b>25</b>
<b>Appendix 5. Channel/Frequency plan .....</b>	<b>26</b>
<b>Appendix 6. Test Set-Up Photographs .....</b>	<b>27</b>

## **1. Customer Information**

### **1.1. Customer Information**

<b>Company Name:</b>	Sirin Labs AG
<b>Address:</b>	Muhlentalstrasse 2 8200 Schaffhausen Switzerland

### **1.2. Manufacturer Information**





<b>Manufacturer Name:</b>	Flextronics International Sweden AB
<b>Address:</b>	Datalinjen 3A SE – 583 30 Linköping Sweden

## 2. Summary of Testing

### 2.1. General Information

<b>FCC Specification Reference:</b>	47CFR15.407
<b>FCC Specification Title:</b>	Code of Federal Regulations Volume 47 (Telecommunications): Part 15 Subpart E (Unlicensed National Information Infrastructure Devices) - Section 15.407
<b>FCC Site Registration:</b>	209735
<b>ISED Canada Specification Reference:</b>	RSS-247 Issue 1, May 28 2015
<b>ISED Canada Specification Title:</b>	Digital Transmission Systems (DTSs), Frequency Hopping Systems (FHSs) and Licence-Exempt Local Area Network (LE-LAN) Devices
<b>ISED Canada Site Registration:</b>	3245B-2
<b>Location of Testing:</b>	UL VS LTD, Unit 3 Horizon, Wade Road, Kingsland Business Park, Basingstoke, Hampshire, RG24 8AH, United Kingdom
<b>Test Date:</b>	16 September 2016

### 2.2. Summary of Test Results

FCC Reference (47CFR)	ISED Canada Reference	Measurement	Result
Part 15.407(h)(2)(iii)	RSS-247 6.3 2)(iii) & 6.3 2)(iv)	Channel Closing Transmission Time and Channel Move Time	
Part 15.407(h)(2)(iv)	RSS-247 6.3 2)(v)	Non-Occupancy Period	
<b>Key to Results</b>			
 = Complied  = Did not comply			

#### Note(s):

- The manufacturer confirms that the information regarding the parameters of the radar waveforms is not available to the end user.
- This non-occupancy period test is not required for a client without radar detection according to Tables 1 and 2 of KDB 905462 D02, however it was performed to show compliance with KDB 905462 D02 5.1.2 e) and KDB 905462 D03, section (b)(5) and (b)(6).

### 2.3. Methods and Procedures

<b>Reference:</b>	FCC KDB 905462 D02 UNII DFS Compliance Procedures New Rules v02 (April 8, 2016)
<b>Title:</b>	Compliance Measurement Procedures for Unlicensed-National Information Infrastructure Devices Operating in the 5250-5350 MHz and 5470-5725 MHz Bands Incorporating Dynamic Frequency Selection

### 2.4. Deviations from the Test Specification

For the measurements contained within this test report, there were no deviations from, additions to, or exclusions from the test specification identified above.

### **3. Equipment Under Test (EUT)**

#### **3.1. Identification of Equipment Under Test (EUT)**

<b>Brand Name / PMN:</b>	SOLARIN
<b>Model Name / HVIN:</b>	SR0020-W
<b>Test Sample Serial Number:</b>	0013 <i>(Conducted sample)</i>
<b>Hardware Version:</b>	TP1
<b>Software Version:</b>	LRC1TA.1.0.2.3
<b>Handset Cover Material:</b>	Technical leather with titanium coating
<b>FCC ID:</b>	2AIP8I
<b>ISED Certification Number:</b>	IC: 21579-I

#### **3.2. Description of EUT**

The equipment under test was a Mobile device supporting Cellular, WLAN, BT, BTLE, RFID & GPS Technologies.

#### **3.3. Modifications Incorporated in the EUT**

No modifications were applied to the EUT during testing.

#### **3.4. Additional Information Related to Testing**

<b>Technology Tested:</b>	WLAN (IEEE 802.11a,n,ac) / Digital Transmission System	
<b>Type of Unit:</b>	Transceiver	
<b>Modulation Type:</b>	BPSK, QPSK, 16QAM, 64QAM & 256QAM	
<b>Data Rate/Mode:</b>	802.11ac VHT80	MCS0
<b>Transmit / Receive Frequency Range:</b>	5250 to 5350 MHz 5470 to 5850 MHz	
<b>Transmit / Receive Channels Tested at 80 MHz Bandwidth setting:</b>	<b>Channel ID</b>	<b>Channel Centre Frequency (MHz)</b>
	106	5530

### **3.5. Support Equipment**

The following support equipment was used to exercise the EUT during testing:

<b>Description:</b>	Wireless Dual Band Router (DFS Master)
<b>Brand Name:</b>	Cisco
<b>Model Name or Number:</b>	AIR-CAP3702E-A-K9 V04
<b>FCC ID:</b>	LDK102087
<b>ISED Canada Certification Number:</b>	IC: 2461B-102087
<b>Serial Number:</b>	FJC1938F3G6

<b>Description:</b>	Laptop PC
<b>Brand Name:</b>	Dell
<b>Model Name or Number:</b>	Latitude E5410
<b>Serial Number:</b>	DQC78L1

## **4. Operation and Monitoring of the EUT during Testing**

### **4.1. Operating Modes**

The EUT was tested in the following operating modes, unless otherwise stated:

- Operating on the channel selected by the Master device in either U-NII Band 2A or U-NII Band 2C.
- The Master device controls the channel bandwidth and modulation of the EUT in set-up 1 shown on the following page . The Master device was set to 802.11ac / MCS0 with 80 MHz channel bandwidth.
- KDB 905462 D02 *U-NII DFS Compliance Procedures* states in Table 2 the EUT should be tested at maximum channel bandwidth (80 MHz for 802.11ac mode). This was performed on an 80 MHz channel bandwidth.
- For the required channel loading of >17% in KDB 905642 D02 7.7(c), a data transfer was performed between a test PC and the EUT. See Appendix 4 *Channel Loading* for further details.

### **4.2. Configuration and Peripherals**

The EUT was tested in the following configuration(s):

- The EUT is a DFS Client without Radar Detection capability. It was tested in combination with an FCC/ISED Canada certified Cisco DFS enabled router being used as the Master (see *Section 3.5: Support Equipment* for further details). A Radar Type 0 was injected to the Master to test the Client's Channel Move Time and Channel Closing Transmission Time after receiving the channel shutdown command from the Master.
- All measurements were made using a conducted link. System losses for the interconnecting hardware were measured and taken into consideration.
- The Radar test platform used was the Aeroflex DFS Radar 110105 Simulator and Analyser which has been verified and accepted by Andrew Leimer of the FCC/NTIA on the 23<sup>rd</sup> of September 2011. Refer to Appendix 2 of this Test Report for the original confirmation email.
- The DFS detection threshold of -61.0 dBm (-62 dBm + 1 dB + 0 dBi) was used at the Master device antenna port. Note this is not dependent on the EUT EIRP, Spectral Density or EUT antenna gain, only the antenna gain of the Master device, as the EUT does not have radar detection.
- The Master device used for test was set to 17 dBm / 50 mW with TPC enabled.
- Plots and data were captured using a Rohde and Schwarz FSV Signal Analyser. The number of data points was increased to maximum and the trace data exported so it could be analysed in far greater detail than available on the built-in display.
- The Channel Move Time was the time taken from the end of the radar waveform to the time the Client (EUT) ceased transmissions. The Channel Closing Transmission Time was calculated to the nearest sample from any additional pulses occurring >200 ms after the end of the radar.



## Setup diagram for test of DFS Client without Radar Detection: Setup 1

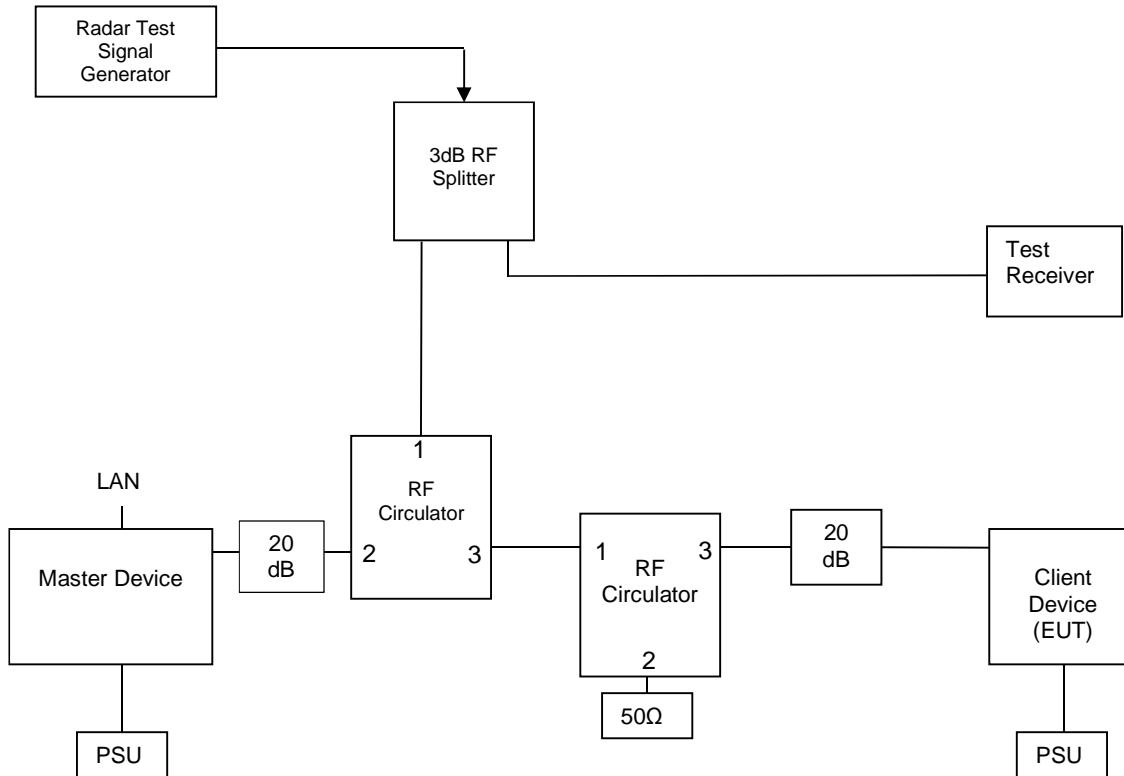

### Rationale

The setup shown above ensures the waveforms indicated on the spectrum analyser are in order of magnitude. The circulators have typically 18 dB attenuation in the reverse direction. The left-hand circulator directs the radar towards the Master, ensuring there is not an overly large radar pulse into the Client (EUT) even though there is the same attenuation between the Client and the radar generator. The radar signal should be approximately 26 dB smaller at the Client antenna port than at the Master. The right-hand circulator is to give the same path loss between Master and Client in both directions of the 802.11 communications link.

The radar signal is most predominant on the spectrum analyser, coming straight through a 3 dB splitter. The Client is 2<sup>nd</sup> largest, being attenuated by the 20 dB, and the (typically 18 dB) isolation from the directional splitter. The smallest signal is the Master, being attenuated by 20 dB from the attenuator and approximately 18 dB from the left-hand circulator and 18 dB across the splitter.

The RF path from the radar generator to the DFS Master crosses no isolated ports of any splitters or circulators and any change of impedance in load between calibration and test is isolated from any circulators by 50  $\Omega$  attenuators which further minimises mismatch. This setup therefore meets the requirements of KDB 905462 D02 clause 7.2 points (1) and (2) whilst providing greater radar generator amplitude headroom and lower radar signal at the Client.

**Applicability of DFS requirements prior to use of a channel**

Requirement	Operational Mode		
	Master	Client Without Radar Detection	Client With Radar Detection
<i>Non-Occupancy Period</i>	Yes	Not required	Yes
<i>DFS Detection Threshold</i>	Yes	Not required	Yes
<i>Channel Availability Check Time</i>	Yes	Not required	Not required
<i>Uniform Spreading</i>	Yes	Not required	Yes

**Applicability of DFS requirements during normal operation**

Requirement	Operational Mode	
	Master Device or Client with Radar Detection	Client Without Radar Detection
<i>DFS Detection Threshold</i>	Yes	Not required
<i>Channel Closing Transmission Time</i>	Yes	Yes
<i>Channel Move Time</i>	Yes	Yes
<i>U-NII Detection Bandwidth</i>	Yes	Not required

Additional requirements for devices with multiple bandwidth modes	Master Device or Client with Radar Detection	Client Without Radar Detection
<i>U-NII Detection Bandwidth and Statistical Performance Check</i>	All BW modes must be tested	Not required
<i>Channel Move Time and Channel Closing Transmission Time</i>	Test using widest BW mode available	Test using the widest BW mode available for the link
<i>All other tests</i>	Any single BW mode	Not required

**Note:** Frequencies selected for statistical performance check (Section 7.8.4) should include several frequencies within the radar detection bandwidth and frequencies near the edge of the radar detection bandwidth. For 802.11 devices it is suggested to select frequencies in each of the bonded 20 MHz channels and the channel center frequency.

**Interference Threshold values, Master or Client incorporating In-Service Monitoring**

Maximum Transmit Power	Value (see notes)
EIRP $\geq$ 200 milliwatt	-64 dBm
EIRP < 200 milliwatt and power spectral density < 10 dBm/MHz	-62 dBm
EIRP < 200 milliwatt that do not meet the power spectral density requirement	-64 dBm

**Note 1:** This is the level at the input of the receiver assuming a 0 dBi receive antenna

**Note 2:** Throughout these test procedures an additional 1dB has been added to the amplitude of the test transmission waveforms to account for variations in measurement equipment. This will ensure that the test signal is at or above the detection threshold level to trigger a DFS response.

**Note 3:** EIRP is based on the highest antenna gain. For MIMO devices refer to KDB Publication 662911 D01.

**DFS Response requirement values**

Parameter	Value
<i>Non-occupancy period</i>	Minimum 30 minutes
<i>Channel Availability Check Time</i>	60 seconds
<i>Channel Move Time</i>	10 seconds See Note 1.
<i>Channel Closing Transmission Time</i>	200 milliseconds + an aggregate of 60 milliseconds over remaining 10 second period. See Notes 1 and 2.
<i>U-NII Detection Bandwidth</i>	Minimum 100% of the U-NII 99% transmission power bandwidth. See Note 3.

**Note 1:** *Channel Move Time* and the *Channel Closing Transmission Time* should be performed with Radar Type 0. The measurement timing begins at the end of the Radar Type 0 burst.

**Note 2:** The *Channel Closing Transmission Time* is comprised of 200 milliseconds starting at the beginning of the *Channel Move Time* plus any additional intermittent control signals required to facilitate a *Channel* move (an aggregate of 60 milliseconds) during the remainder of the 10 second period. The aggregate duration of control signals will not count quiet periods in between transmissions.

**Note 3:** During the *U-NII Detection Bandwidth* detection test, radar type 0 should be used. For each frequency step the minimum percentage of detection is 90 percent. Measurements are performed with no data traffic.

**Short Pulse Radar Test Waveforms**

Radar Type	Pulse Width (Microseconds)	PRI (Microseconds)	Pulses	Minimum Percentage of Successful Detection	Minimum Trials
0	1	1428	18	See Note 1	See Note 1

**Note 1:** Short Pulse Radar Type 0 should be used for the detection bandwidth test, channel move time, and channel closing time tests.

## **5. Measurements, Examinations and Derived Results**

### **5.1. General Comments**

Measurement uncertainties are evaluated in accordance with current best practice. Our reported expanded uncertainties are based on standard uncertainties, which are multiplied by an appropriate coverage factor to provide a statistical confidence level of approximately 95%. Please refer to *Section 6 Measurement Uncertainty* for details.

In accordance with UKAS requirements all the measurement equipment is on a calibration schedule. All equipment was within the calibration period on the date of testing.

## 5.2. Test Results

### 5.2.1. Channel Closing Transmission Time and Channel Move Time

#### Test Summary:

Test Engineer:	Philip Harrison	Test Date:	16 September 2016
Test Sample Serial Numbers:	0013		

FCC Reference:	Part 15.407(h)(2)(iii)
ISED Canada Reference:	RSS-247 6.3 2)(iii) & 6.3 2)(iv)
Test Method Used:	KDB 905462 D02 Section 7.8.3

#### Environmental Conditions:

Temperature (°C):	22
Relative Humidity (%):	51

#### Note(s):

1. The channel move time is the time taken from the end of the radar burst to the ceasing of transmissions of the EUT and compared to the 10000 ms limit.
2. The Total Aggregate Channel Closing Transmission Time shown in the table below was measured from 200 ms after the end of the radar burst and compared to the 60 ms limit.
3. The smaller transmissions seen in the plot that are not included in the move time come from the Master device and not from the Client, these transmissions can be ignored for the below results.
4. The path losses from the EUT to the spectrum analyser were incorporated in the measurements.
5. All transmissions after the reported channel move time were from the router.

#### Results:

Channel Frequency (MHz)	Channel Move Time (ms)	Total Aggregate Channel Closing Time after first 200 ms (ms)	Limit (ms)	Margin (ms)	Result
5320	73.8	-	10000	9926.2	Complied
5320	-	47.5	60	12.5	Complied

Radar burst type 0 was detected and channel move occurred.

**Channel Closing Transmission Time and Channel Move Time (continued)**

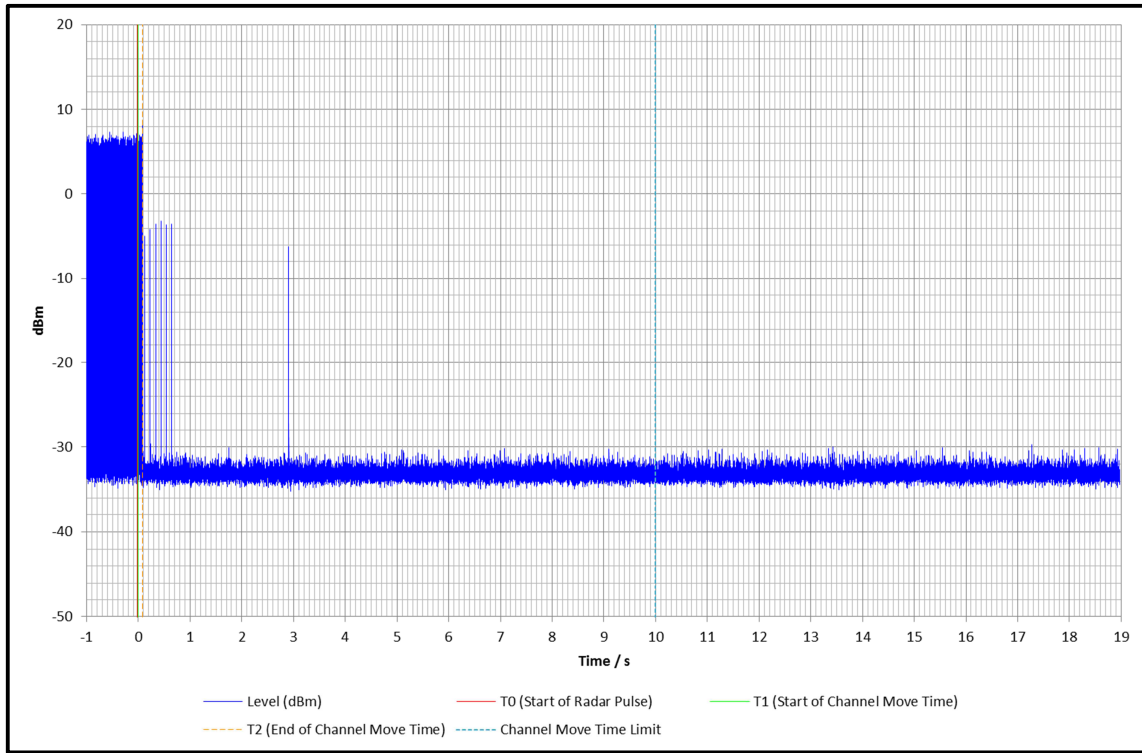

**Channel Move Time 5320 MHz – Short Radar (Type 0) – Full 10 seconds**

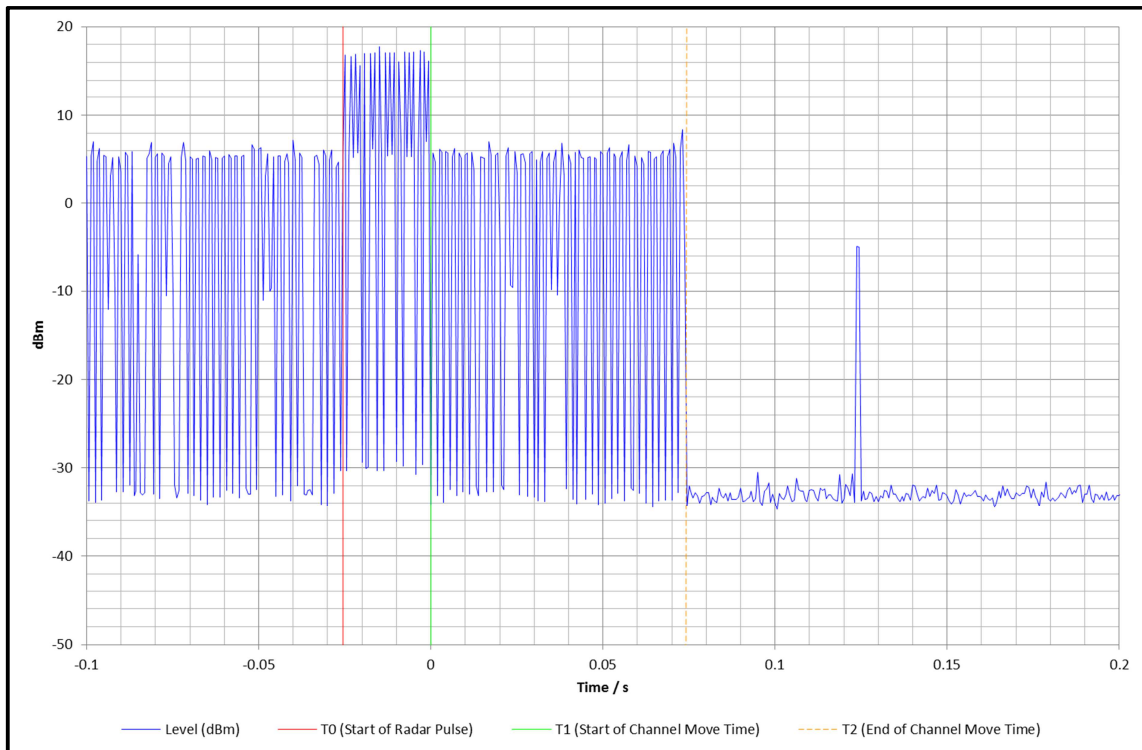

**Channel Move Time 5320 MHz – Short Radar (Type 0) – Zoomed Plot**

**Channel Closing Transmission Time and Channel Move Time (continued)****Test Equipment Used:**

Asset No.	Instrument	Manufacturer	Type No.	Serial No.	Date Calibration Due	Cal. Interval (Months)
M1631	DFS Test System	Aeroflex	PXI 3000	300110/291	09 Jul 2017	24
M1883	Signal Analyser	Rohde & Schwarz	FSV-30	103084	09 May 2017	12
A1535	Step Attenuator	Hewlett Packard	8495B/8494B	00007	Calibrated before use	-
A1536	Step Attenuator	Hewlett Packard	8495B/8494B	3308A30801/ 3308A19649	Calibrated before use	-
A2181	Coaxial Circulator 4 – 18 GHz	Atlantec	ACC-20130- SF-SF-SF	120409229	Calibrated before use	-
A2183	Coaxial Circulator 4 – 18 GHz	Atlantec	ACC-20130- SF-SF-SF	120409232	Calibrated before use	-
A2119	Power Splitter	Mini-Circuits	ZN2PD-63- S+	SUU1270120 3	Calibrated before use	-
A162	50Ω Termination	Narda	3768NM	5204	Calibrated before use	-
A2491	50Ω Termination	Narda	TA06W5-M	121813#2	Calibrated before use	-
A2494	50Ω Termination	Narda	TA06W5-F	082013#2	Calibrated before use	-
M2001	Thermohygrometer	Testo	608-H1	45041824	02 Apr 2017	12

**5.2.2. Non-Occupancy Period****Test Summary:**

<b>Test Engineer:</b>	Philip Harrison	<b>Test Date:</b>	16 September 2016
<b>Test Sample Serial Number:</b>	0013		

<b>FCC Reference:</b>	Part 15.407(h)(iv)
<b>ISED Canada Reference:</b>	RSS-247 6.3 2)(v)
<b>Test Method Used:</b>	KDB 905462 D02 Section 7.8.3

**Environmental Conditions:**

<b>Temperature (°C):</b>	22
<b>Relative Humidity (%):</b>	51

**Notes:**

1. This test is not required for a client without radar detection according to Tables 1 and 2 of KDB 905462 D02, however it was performed to show compliance with KDB 905462 D02 5.1.2 e) and KDB 905462 D03, section (b)(5) and (b)(6). Therefore no specified bandwidth requirement is given and so was performed using an 80 MHz channel bandwidth; as used for *Channel Closing Transmission Time and Channel Move Time*.
2. Radar burst type 0 was detected and the channel was vacated for >1800 seconds. Since the client has no radar detection and is therefore not performing an 'intelligent' blacklisting of the channel, the device was shown not to transmit for greater than 30 minutes after its own shutdown time, not the shutdown of the DFS master.
3. The noise floor remains below the -27 dBm/MHz spurious limit for the 30 minute (1800 second) non-occupancy period, except where the other devices are still transmitting and are yet to have shutdown. Therefore the EUT is deemed to comply.



**Non-occupancy Period (continued)**

**Results:**

Channel (MHz)	Trial	Non-Occ (min)	Limit (min)	Margin (min)	Result
5500	1	>34	30	>4	Complied

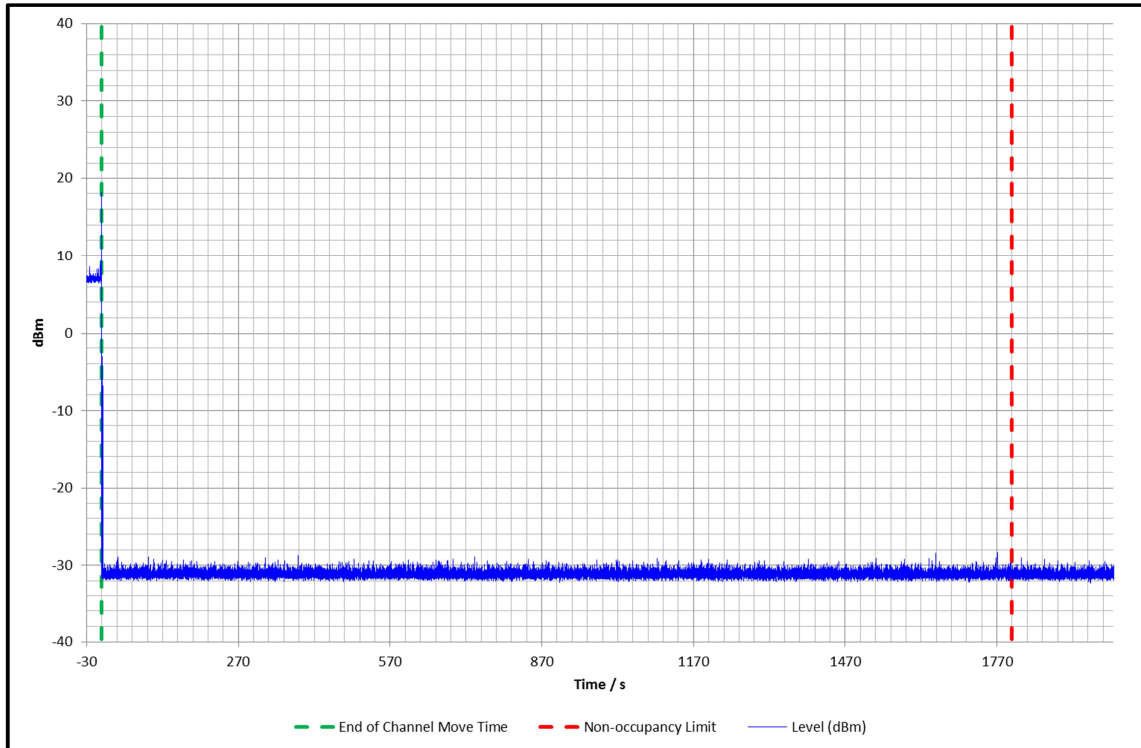

**Limits:**

**Part 15.407(h)(2)(iv)**

A channel that has been flagged as containing a radar system, either by a channel availability check or in-service monitoring, is subject to a non-occupancy period of at least 30 minutes. The non-occupancy period starts at the time when the radar system is detected.

**RSS-247 6.3 2)(v)**

A channel that has been flagged as containing a radar signal, either by a channel availability check or in-service monitoring, is subject to a 30-minute non-occupancy period where the channel cannot be used by the LE-LAN device. The non-occupancy period starts from the time that the radar system is detected.

**KDB 905462 D02 Table 4: DFS Response Requirement Values**

Parameter	Value
Non-occupancy period	Minimum 30 minutes

**Non-occupancy Period (continued)****Test Equipment Used:**

Asset No.	Instrument	Manufacturer	Type No.	Serial No.	Date Calibration Due	Cal. Interval (Months)
M1631	DFS Test System	Aeroflex	PXI 3000	300110/291	09 Jul 2017	24
M1883	Signal Analyser	Rohde & Schwarz	FSV-30	103084	09 May 2017	12
A1535	Step Attenuator	Hewlett Packard	8495B/8494B	00007	Calibrated before use	-
A1536	Step Attenuator	Hewlett Packard	8495B/8494B	3308A30801/ 3308A19649	Calibrated before use	-
A2181	Coaxial Circulator 4 – 18 GHz	Atlantec	ACC-20130- SF-SF-SF	120409229	Calibrated before use	-
A2183	Coaxial Circulator 4 – 18 GHz	Atlantec	ACC-20130- SF-SF-SF	120409232	Calibrated before use	-
A2119	Power Splitter	Mini-Circuits	ZN2PD-63- S+	SUU1270120 3	Calibrated before use	-
A162	50Ω Termination	Narda	3768NM	5204	Calibrated before use	-
A2491	50Ω Termination	Narda	TA06W5-M	121813#2	Calibrated before use	-
A2494	50Ω Termination	Narda	TA06W5-F	082013#2	Calibrated before use	-
M2001	Thermohygrometer	Testo	608-H1	45041824	02 Apr 2017	12

## **6. Measurement Uncertainty**

No measurement or test can ever be perfect and the imperfections give rise to error of measurement in the results. Consequently the result of a measurement is only an approximation to the value of the measurand (the specific quantity subject to measurement) and is only complete when accompanied by a statement of the uncertainty of the approximation.

The expression of uncertainty of a measurement result allows realistic comparison of results with reference values and limits given in specifications and standards.

The uncertainty of the result may need to be taken into account when interpreting the measurement results.

The reported expanded uncertainties below are based on a standard uncertainty multiplied by an appropriate coverage factor such that a confidence level of approximately 95% is maintained. For the purposes of this document "approximately" is interpreted as meaning "effectively" or "for most practical purposes".

<b>Measurement Type</b>	<b>Range</b>	<b>Confidence Level (%)</b>	<b>Calculated Uncertainty</b>
DFS Radar Amplitude	5.25 GHz to 5.85 GHz	95%	±2.17 dB
Channel Shutdown Timing	5.25 GHz to 5.85 GHz	95%	±0.45 ms
Non-Occupancy Timing	5.25 GHz to 5.85 GHz	95%	±79.25 ms

The methods used to calculate the above uncertainties are in line with those recommended within the various measurement specifications. Where measurement specifications do not include guidelines for the evaluation of measurement uncertainty the published guidance of the appropriate accreditation body is followed.

## **7. Report Revision History**

Version Number	Revision Details		
	Page No(s)	Clause	Details
1.0	-	-	Initial Version

## **Appendix 1. Radar Calibration**

### **Radar calibration procedure.**

All radars were generated and produced by an Aeroflex DFS test system. The radar pulse generation of this system has previously been verified by the FCC (see Appendix 4).

The radar amplitude was calibrated using the setup diagram shown below. The spectrum analyser was replaced by a 50Ω load. The DFS Master was replaced by a spectrum analyser. The Aeroflex DFS test system was then set to transmit a CW signal with which to calibrate the radar level. The output level was adjusted to give the correct level into the Master device, as calculated in Section 4 of this Test Report, before the tests were performed.

### **Radar Verification**

The test system and its waveform generation has been validated by the FCC as an 'approved' device (see Appendix 2), so full analysis of each radar is not necessary. However, below are sample plots for each of the radar types. Note the timing plots of all the pulses in the waveform have inaccurate amplitudes. This is due to the amplitude being increased for timing verification due to the high noise floor of the signal analyser used when using wide RBW/VBW filters to avoid pulse desensitisation of the spectrum analyser. They are therefore accurate only as an example radar overview and for basic validation. Full more accurate validation has been performed previously with more suitable equipment.

**Radar Type 0**

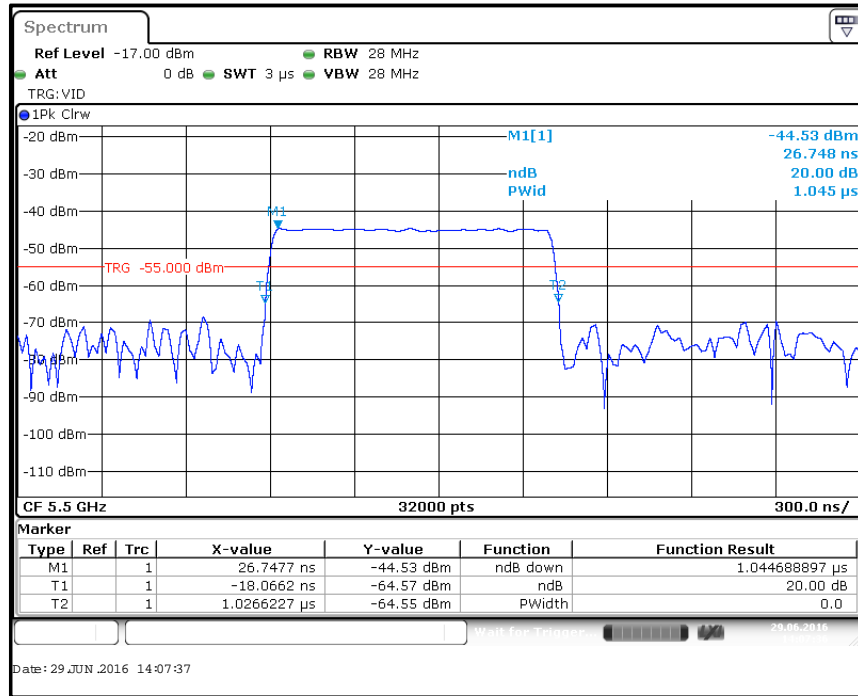

Radar Type 0 – single 1 μs pulse

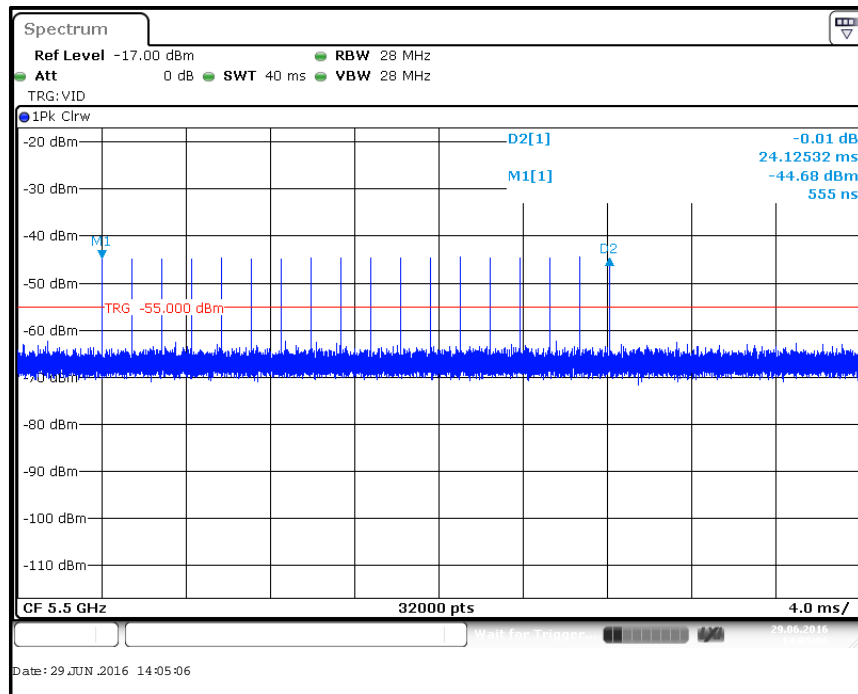

Radar Type 0 – full 18 pulse waveform

**Appendix 2. Aeroflex Test Platform Approval email**

From: Andrew Leimer [<mailto:Andrew.Leimer@fcc.gov>]  
Sent: Friday, September 23, 2011 4:24 PM  
To: Chisham, Steve  
Cc: Carey, Tim; Hack, Barry; Rashmi Doshi; Joe Dichoso  
Subject: RE: Certification for Aeroflex DFS solution

Hello Steve,

The Aeroflex "DXI based DFS test solution" system used for DFS alternative radar signal generation has been approved by the FCC and NTIA.

This approval permits the system to be used by labs in the testing of DFS devices for equipment authorization Certification. It is recommended that applicants that use your system for testing include a statement in the Test Report or a Letter Exhibit stating that the system has FCC and NTIA approval. This E-mail is your record of this approval.

Note that the appropriate term for your system is Approved as the term Certification is reserved for devices gaining equipment authorization through the FCC or a TCB.

Regards,

Andy Leimer

FCC/OET/EACB

### Appendix 3. System Noise Floor Reference Plots

As required by Section 8.3(d)(3) of KDB 905462 D02, the following plot shows the reference noise floor of the system used during measurement. It also shows compliance when the path loss of the coupling network shown in Section 4.2 of this Test Report (*Configuration and Peripherals*) is added to the noise floor as a reference level offset.

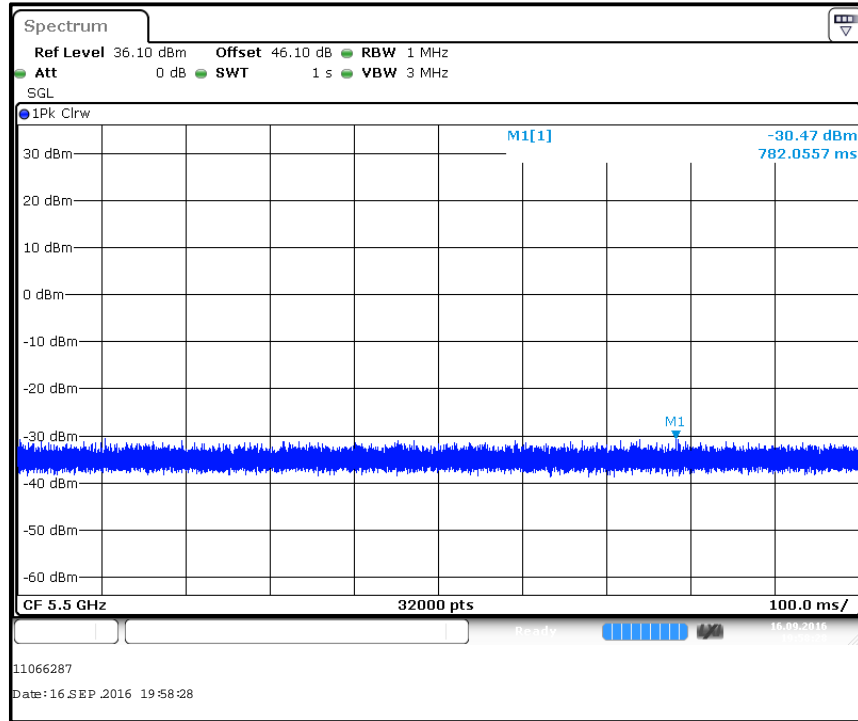

Noise Floor of Spectrum Analyser



### Appendix 4. Channel Loading

As required by Section 8.3(c)(6) of KDB 605642 D02, the following plot and calculations shows the duty cycle of the channel used during testing.

Streaming representative file types as defined in Section 7.7(a) of KDB 605642 D02, were found not to produce a high enough continuous duty cycle of >17%, as required by 7.7(c), on an 80 MHz channel bandwidth. This included lowest data rate with modulation coding scheme MCS0, maximum video size (1080p) and the minimum video compression ratio during encoding. Therefore alternative pseudo-random data transfer as per 7.7(b) was streamed to simulate data transfer. A suitable duty cycle was obtained using iPerf2 with a 12 Mbit/s UDP data transfer.

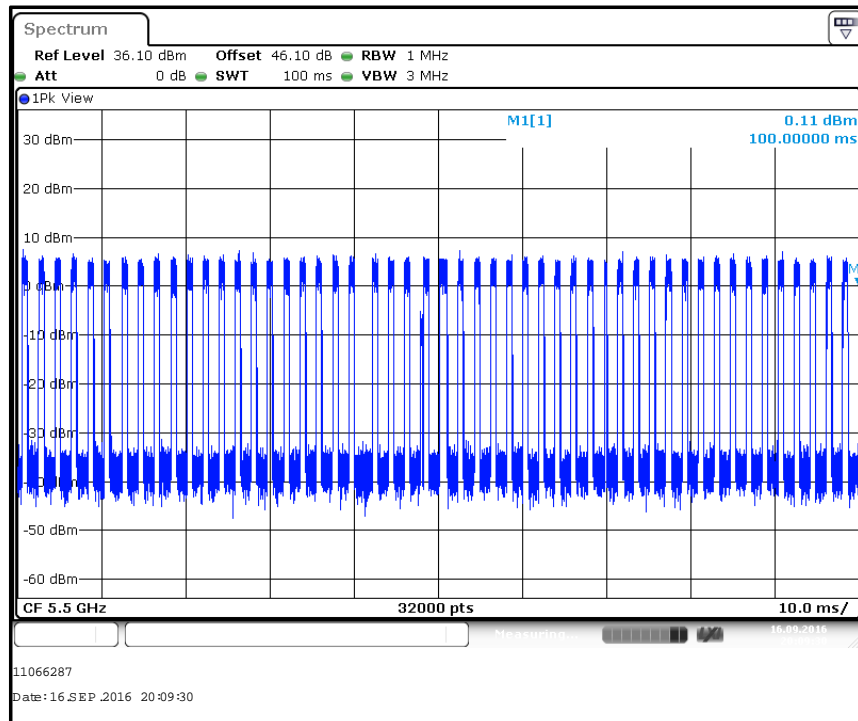

The number of samples greater than -10 dBm was compared to the total number of samples to calculate the duty cycle. The EUT and test router were found to be transmitting above this threshold for 33.4% of the total, and therefore meeting the requirement of greater than 17% channel loading.

## **Appendix 5. Channel/Frequency plan**

<b>Wi-Fi Supported Channels</b>			
<b>Country</b>	<b>Channels</b>		
	20 MHz	40 MHz	80 MHz
United States	1 - 13 36 - 48 52 - 64 100 - 144 149 - 165	38 & 46 54 & 62 102 - 142 151 & 159	42 & 58 106, 122 & 138 155
Canada	1 - 13 36 - 48 52 - 64 100 - 116 & 132 - 140 149 - 165	38 & 46 54 & 62 102, 110 & 134 151 & 159	42 & 58 106 155

### **Note(s):**

1. FCC: Channels 120 – 128: Only used if DFS Master allows
2. Channels 36 – 48: Set to Indoor use only for Canada
3. The following channels are set to Active/Passive in FCC domain:

#### **2.4 GHz Band**

Channels 1 – 11: Active  
Channels 12 – 13: Passive

#### **5 GHz Band**

Channels 36 – 48: Active  
Channels 52 – 144: Passive DFS  
Channels 149 – 165: Active

**Appendix 6. Test Set-Up Photographs**

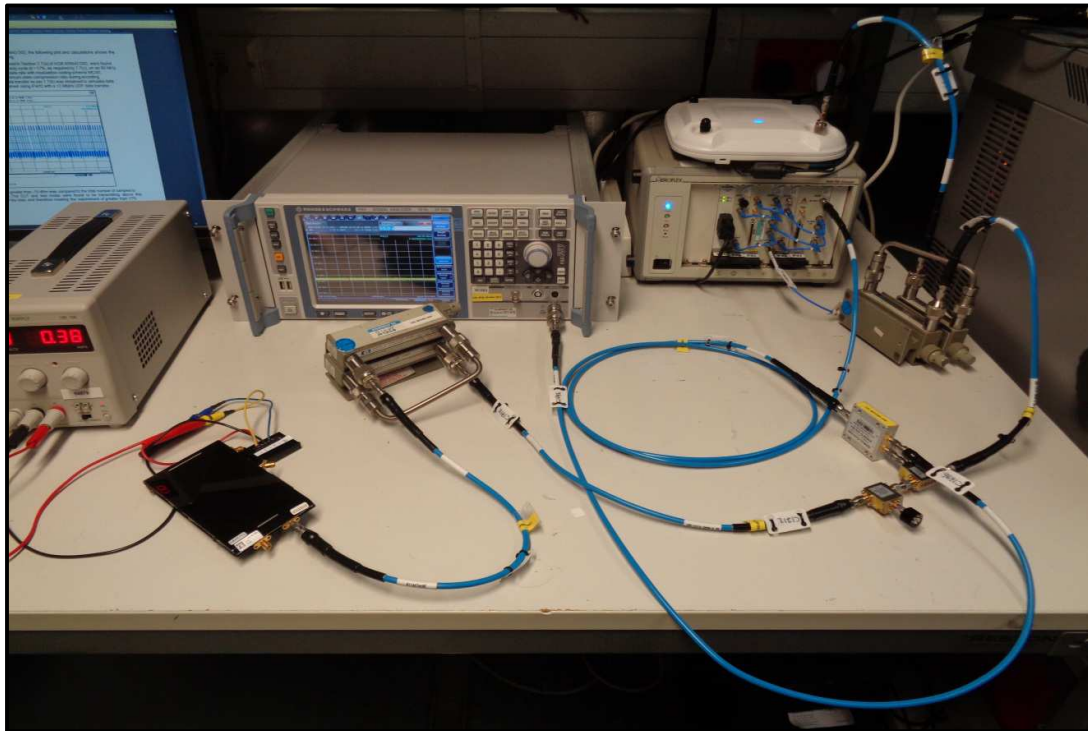

--- END OF REPORT ---