

Transmitter 26 dB Emission Bandwidth (continued)

Results: Reference Plots / 802.11n / 40 MHz / 5.47-5.725 GHz band / Port 2

Channel	Frequency (MHz)	Modulation scheme	Data Rate Mbps / MCS	26 dB Emission Bandwidth (MHz)
Bottom	5510	BPSK	13.5 / 0	41.332
Middle	5550	BPSK	13.5 / 0	41.505
Top	5670	BPSK	13.5 / 0	41.505

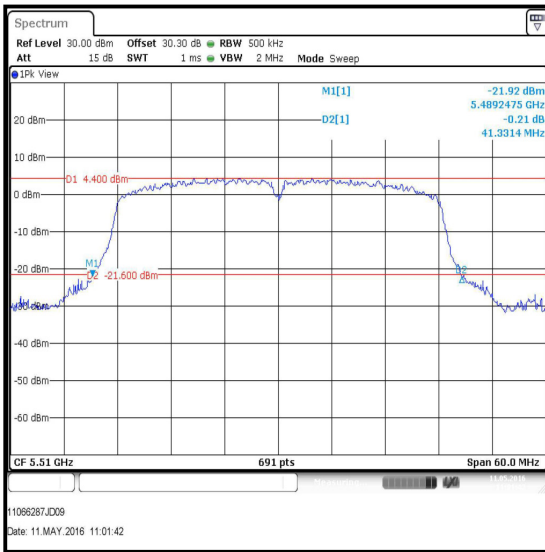

Bottom Channel

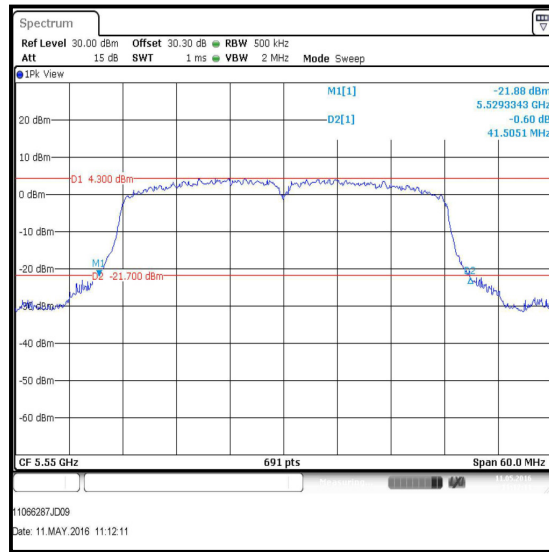

Middle Channel

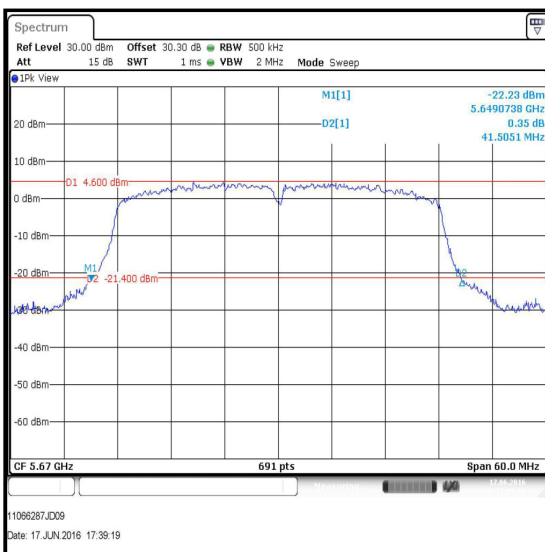

Top Channel

Transmitter 26 dB Emission Bandwidth (continued)

Results: 802.11n / 40 MHz / Channels that straddle the U-NII-2C and U-NII-3 bands at 5725 MHz / Port 1

Channel	Frequency (MHz)	Modulation scheme	Data Rate Mbps / MCS	26 dB Emission Bandwidth (MHz)
Single	5710	BPSK	13.5 / 0	41.245

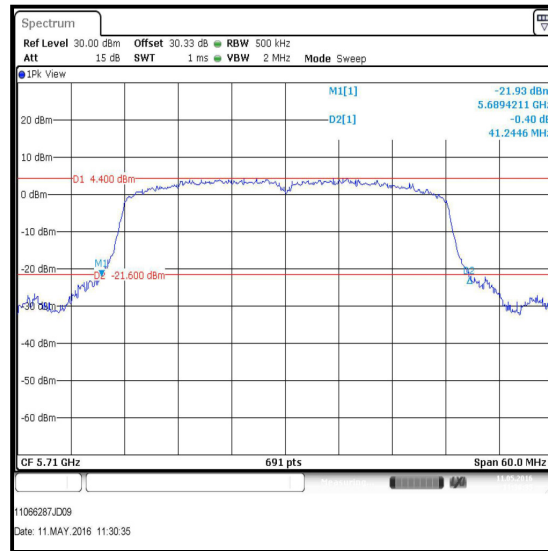

Single Channel

Transmitter 26 dB Emission Bandwidth (continued)

Results: 802.11n / 40 MHz / Channels that straddle the U-NII-2C and U-NII-3 bands at 5725 MHz / Port 2

Channel	Frequency (MHz)	Modulation scheme	Data Rate Mbps / MCS	26 dB Emission Bandwidth (MHz)
Single	5710	BPSK	13.5 / 0	41.592

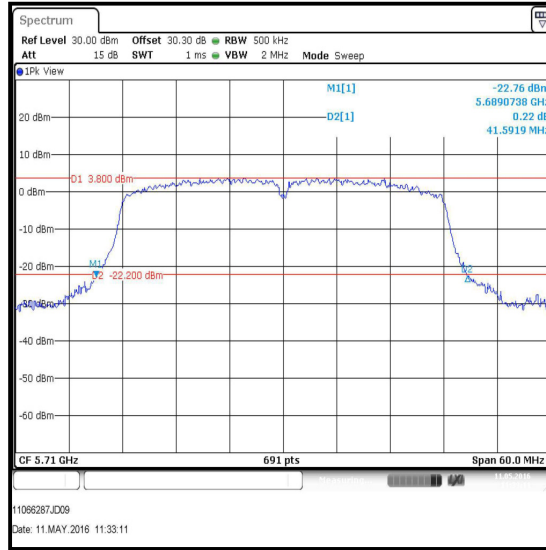

Single Channel

Transmitter 26 dB Emission Bandwidth (continued)

Results: Reference Plots / 802.11n / 40 MHz / 5.725 - 5.85 GHz band / Port 1

Channel	Frequency (MHz)	Modulation scheme	Data Rate Mbps / MCS	26 dB Emission Bandwidth (MHz)
Bottom	5755	BPSK	13.5 / 0	41.158
Top	5795	BPSK	13.5 / 0	41.419

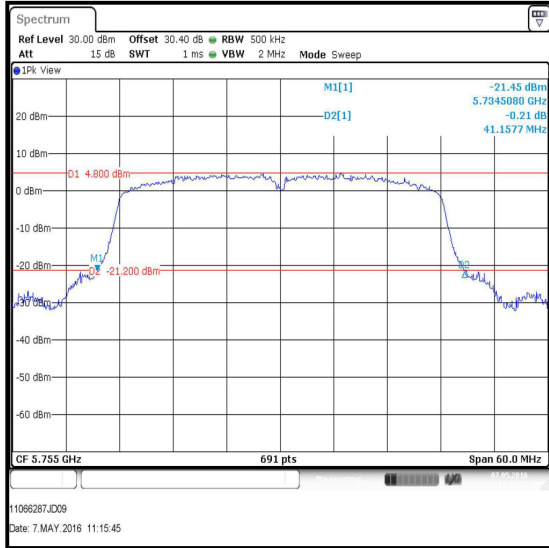

Bottom Channel



Top Channel

Transmitter 26 dB Emission Bandwidth (continued)

Results: Reference Plots / 802.11n / 40 MHz / 5.725 - 5.85 GHz band / Port 2

Channel	Frequency (MHz)	Modulation scheme	Data Rate Mbps / MCS	26 dB Emission Bandwidth (MHz)
Bottom	5755	BPSK	13.5 / 0	41.506
Top	5795	BPSK	13.5 / 0	41.158

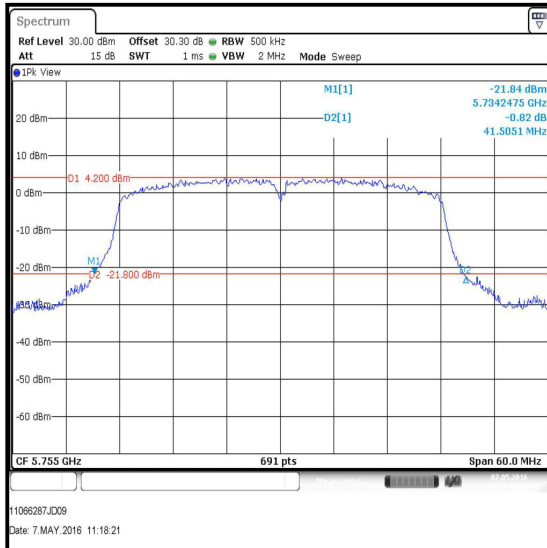

Bottom Channel

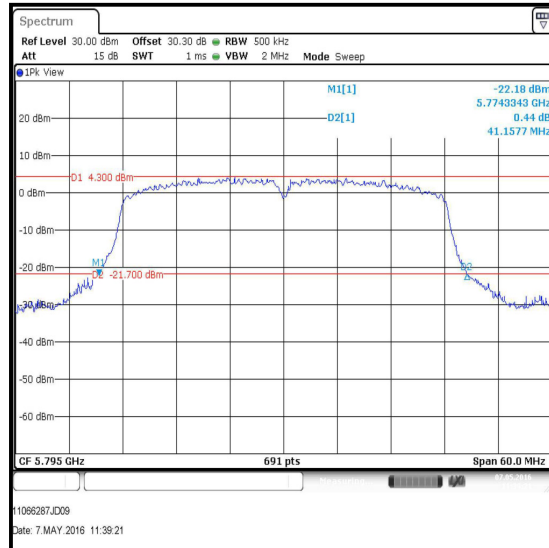

Top Channel

Test Equipment Used:

Asset No.	Instrument	Manufacturer	Type No.	Serial No.	Date Calibration Due	Cal. Interval (Months)
M2002	Thermohyrometer	Testo	608-H1	45041825	02 Apr 2017	12
M1873	Signal Analyser	Rohde & Schwarz	FSV30	103074	03 Jul 2016	12
M1867	Attenuator	Huber + Suhner AG	6820.17.B	07101	Calibrated before use	-
A2847	Attenuator	Radiall	R411.820.121	24671450	Calibrated before use	-
A2345	Attenuator	Macom	2082-6043-20	None stated	Calibrated before use	-
A2952	RF Switch	Pickering Interfaces	64-102-002 & 40-881-001	XZ340281 & X311198	Calibrated before use	-
S0538	DC Power Supply	TTi	PL154	250135	Calibrated before use	-
M1269	Multimeter	Fluke	175	90250210	13 May 2017	12
M1252	Signal Generator	Hewlett Packard	83640A	3119A00489	26 Oct 2017	24

5.2.3. Transmitter Minimum 6 dB Bandwidth

Test Summary:

Test Engineer:	Georgios Vrezas	Test Dates:	06 May 2016 & 12 May 2016
Test Sample IMEI:	357232070003098		

FCC Reference:	Part 15.407(e)
Test Method Used:	KDB 789033 D02 Section II.C.2.

Environmental Conditions:

Temperature (°C):	24 to 26
Relative Humidity (%):	31 to 42

Note(s):

- All configurations supported by the EUT were investigated on one channel in accordance with KDB 789033 Section II.C.2. Minimum Emission Bandwidth for the band 5.725-5.85 GHz measurement procedure. The data rates that produced the narrowest bandwidth and therefore deemed worst case were:
 - 802.11a – BPSK / 9 Mbps
 - 802.11n HT20 – BPSK / 13 Mbps / MCS8
 - 802.11n HT40 – BPSK / 27 Mbps / MCS8
 - 802.11ac VHT80 – BPSK / 29.3 Mbps / MCS0x1
- Final measurements were performed using the above configurations on the bottom, middle and top channels.
- For channels that straddle the U-NII-2C and U-NII-3 bands at 5725 MHz, measurements were made on the portion of the emission bandwidth that is contained within the U-NII-3 band.
- Plots for all data rates are archived on the Company server and available for inspection upon request.
- The signal analyser was connected to the RF port on the EUT using an RF switch, suitable attenuation and RF cables. An RF level offset was entered on the signal analyser to compensate for the loss of the switch, attenuators and RF cables.

Test setup:

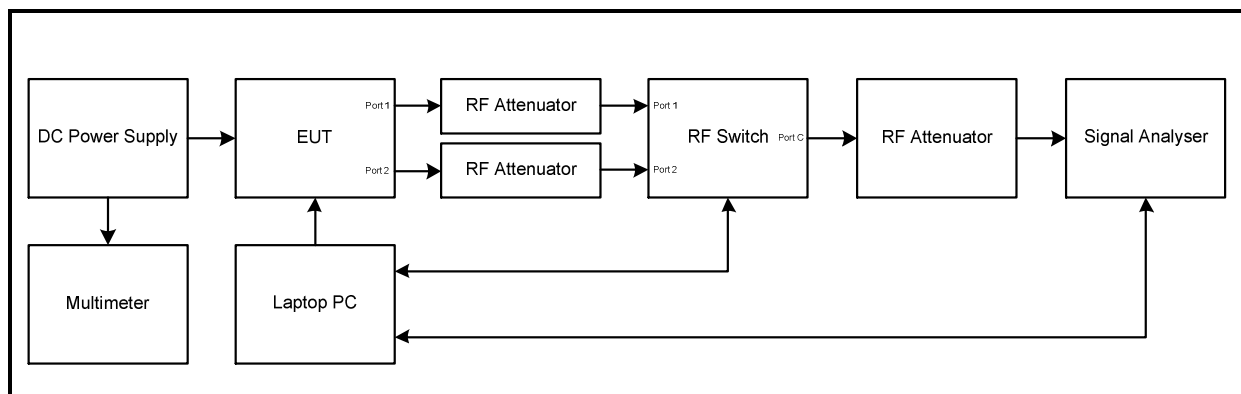

Transmitter Minimum 6 dB Bandwidth (Channels that straddle the U-NII-2C and U-NII-3 bands at 5725 MHz) (continued)

Results: 802.11a / 20 MHz / BPSK / 9 Mbps / Port 1

Channel	6 dB Bandwidth (kHz)	Limit (kHz)	Margin (kHz)	Result
Single	3292	≥500	2792	Complied

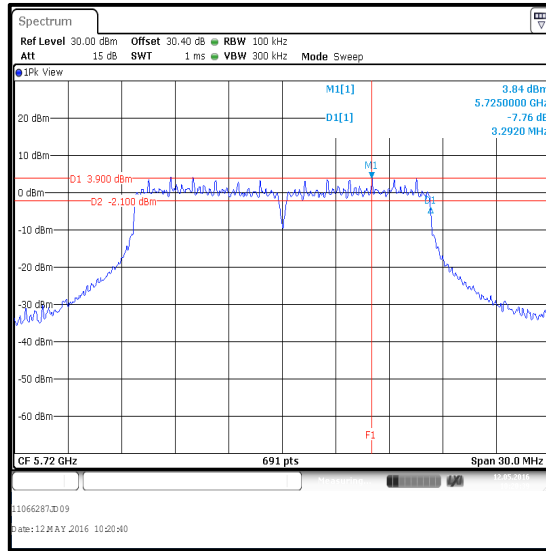

Single Channel

Results: 802.11a / 20 MHz / BPSK / 9 Mbps / Port 2

Channel	6 dB Bandwidth (kHz)	Limit (kHz)	Margin (kHz)	Result
Single	3292	≥500	2792	Complied

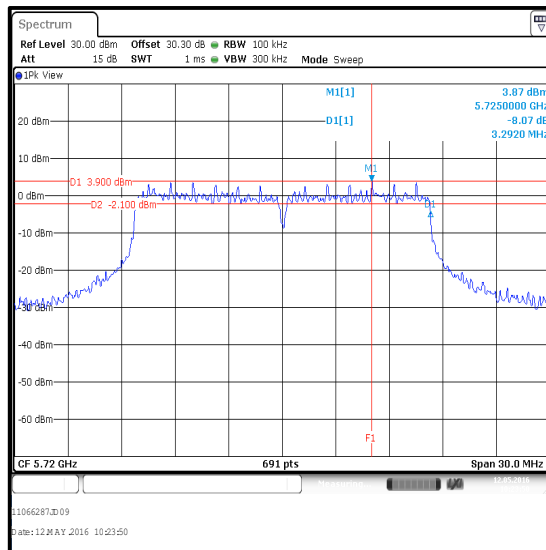

Single Channel

Transmitter Minimum 6 dB Bandwidth (Channels that straddle the U-NII-2C and U-NII-3 bands at 5725 MHz) (continued)

Results: 802.11n / 20 MHz / BPSK / MCS8 / Port 1

Channel	6 dB Bandwidth (kHz)	Limit (kHz)	Margin (kHz)	Result
Single	2641	≥500	2141	Complied

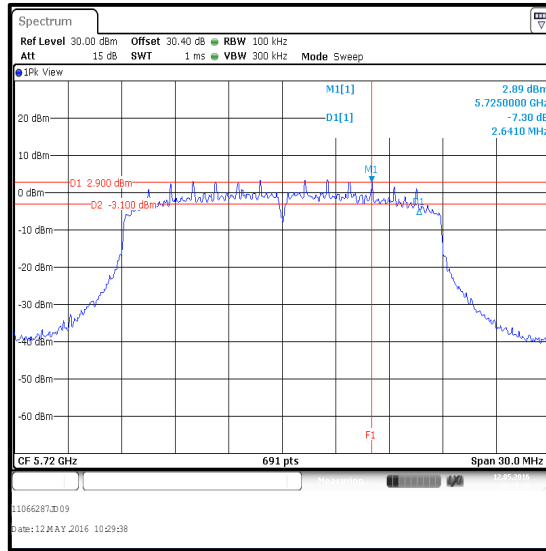

Single Channel

Results: 802.11n / 20 MHz / BPSK / MCS8 / Port 2

Channel	6 dB Bandwidth (kHz)	Limit (kHz)	Margin (kHz)	Result
Single	2641	≥500	2141	Complied

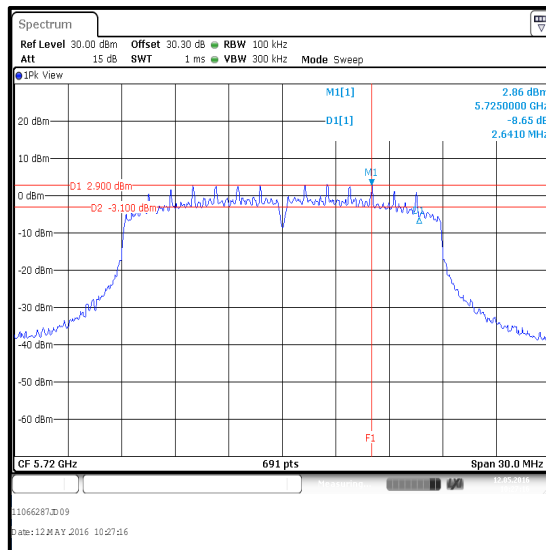

Single Channel

Transmitter Minimum 6 dB Bandwidth (Channels that straddle the U-NII-2C and U-NII-3 bands at 5725 MHz) (continued)

Results: 802.11n / 40 MHz / BPSK / MCS8 / Port 1

Channel	6 dB Bandwidth (kHz)	Limit (kHz)	Margin (kHz)	Result
Single	2902	≥500	2402	Complied

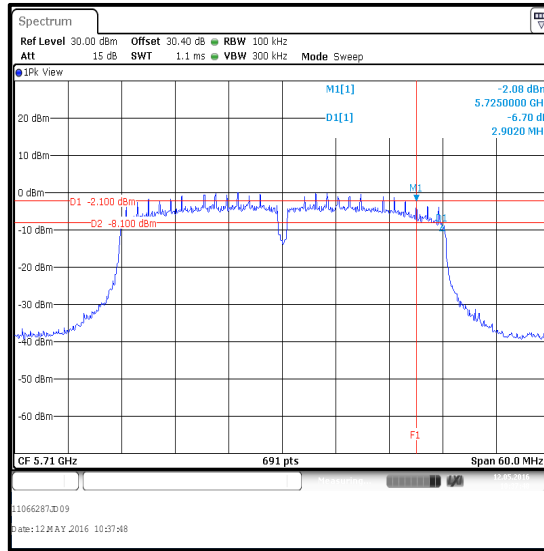

Single Channel

Results: 802.11n / 40 MHz / BPSK / MCS8 / Port 2

Channel	6 dB Bandwidth (kHz)	Limit (kHz)	Margin (kHz)	Result
Single	2728	≥500	2228	Complied

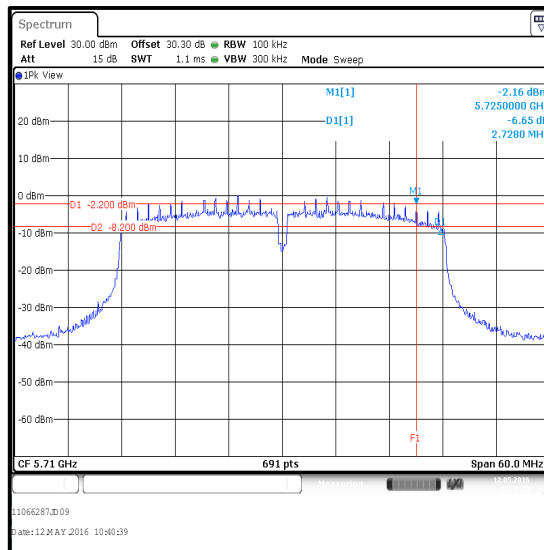

Single Channel

Transmitter Minimum 6 dB Bandwidth (Channels that straddle the U-NII-2C and U-NII-3 bands at 5725 MHz) (continued)

Results: 802.11ac / 80 MHz / BPSK / MCS0x1 / Port 1

Channel	6 dB Bandwidth (kHz)	Limit (kHz)	Margin (kHz)	Result
Single	3390	≥500	2890	Complied

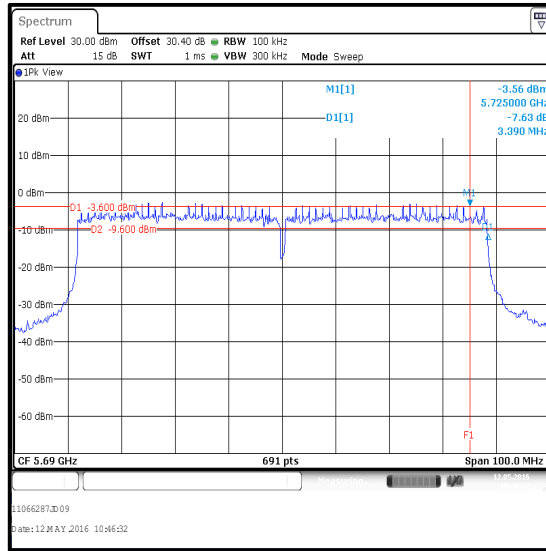

Single Channel

Results: 802.11ac / 80 MHz / BPSK / MCS0x1 / Port 2

Channel	6 dB Bandwidth (kHz)	Limit (kHz)	Margin (kHz)	Result
Single	3390	≥500	2890	Complied

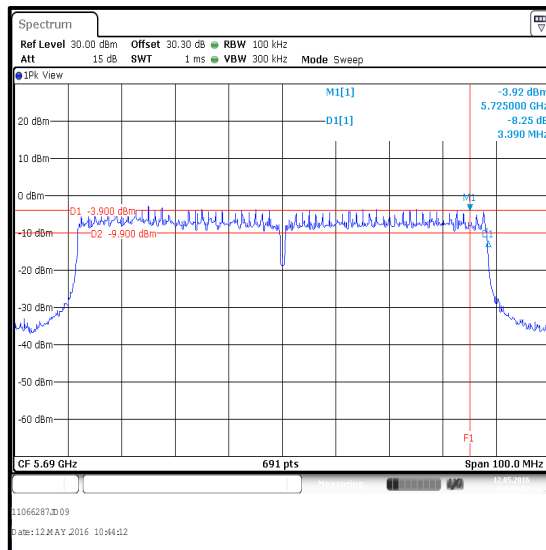

Single Channel

Transmitter Minimum 6 dB Bandwidth (5.725-5.85 GHz band) (continued)

Results: 802.11a / 20 MHz / BPSK / 9 Mbps / Port 1

Channel	6 dB Bandwidth (kHz)	Limit (kHz)	Margin (kHz)	Result
Bottom	15239	≥500	14739	Complied
Middle	15239	≥500	14739	Complied
Top	15239	≥500	14739	Complied

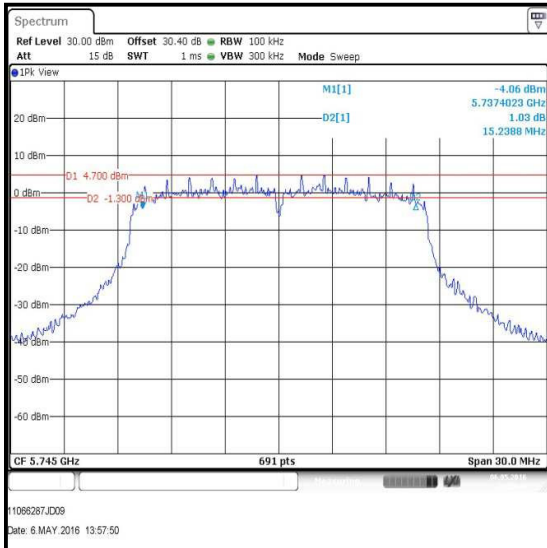

Bottom Channel

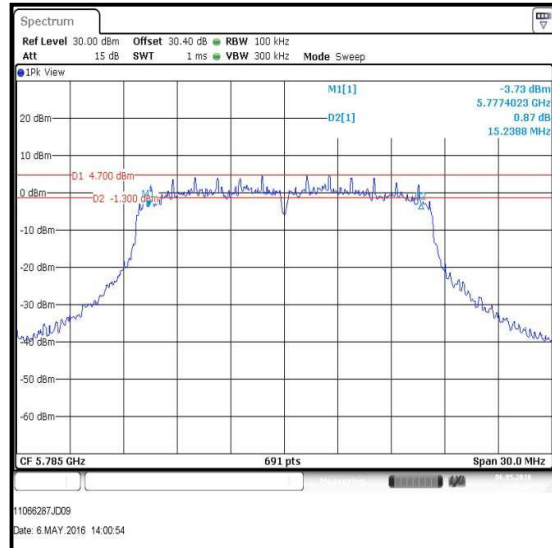

Middle Channel

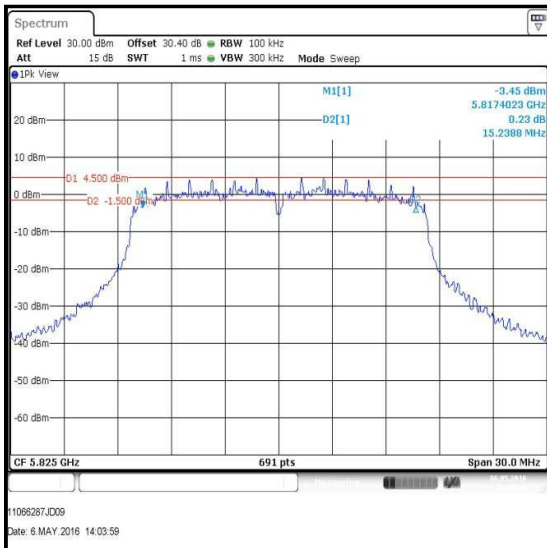

Top Channel

Transmitter Minimum 6 dB Bandwidth (5.725-5.85 GHz band) (continued)

Results: 802.11a / 20 MHz / BPSK / 9 Mbps / Port 2

Channel	6 dB Bandwidth (kHz)	Limit (kHz)	Margin (kHz)	Result
Bottom	15195	≥500	14695	Complied
Middle	15195	≥500	14695	Complied
Top	15239	≥500	14739	Complied

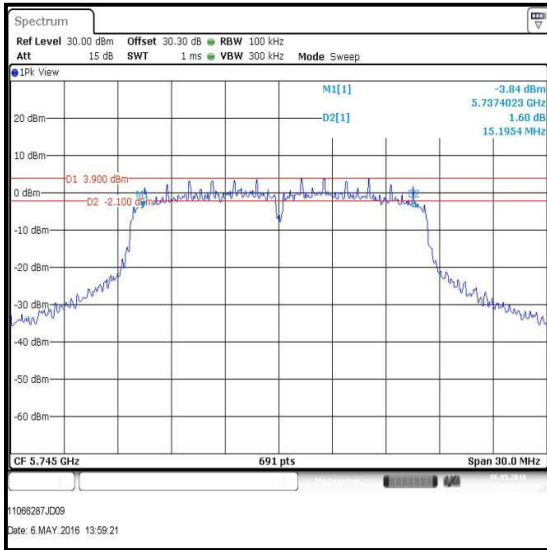

Bottom Channel

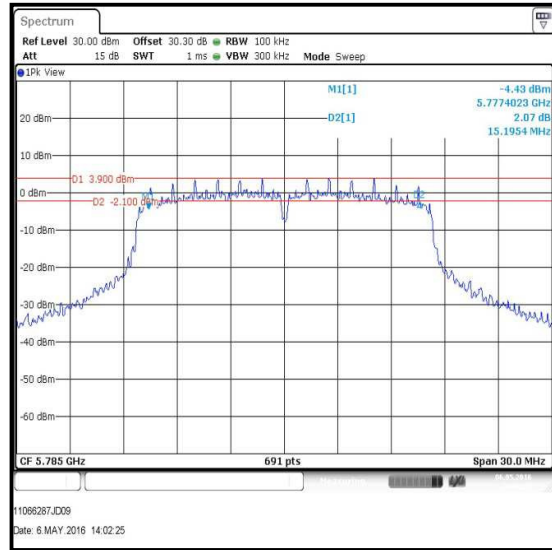

Middle Channel

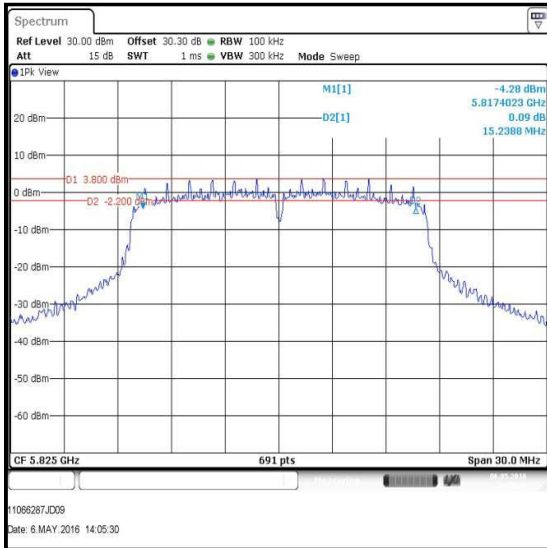

Top Channel

Transmitter Minimum 6 dB Bandwidth (5.725-5.85 GHz band) (continued)

Results: 802.11n / 20 MHz / BPSK / MCS8 / Port 1

Channel	6 dB Bandwidth (kHz)	Limit (kHz)	Margin (kHz)	Result
Bottom	15239	≥500	14739	Complied
Middle	15239	≥500	14739	Complied
Top	15239	≥500	14739	Complied

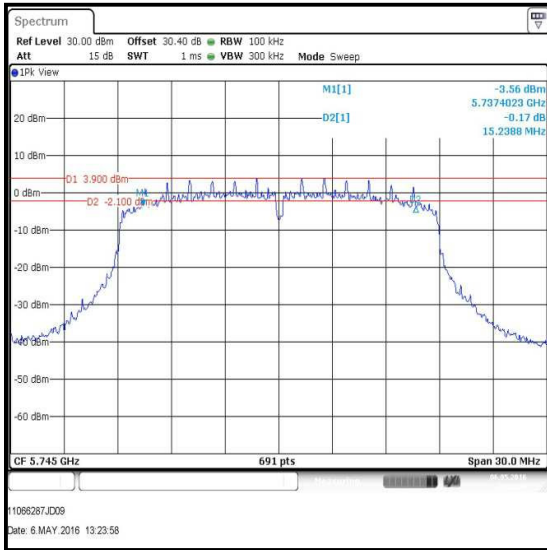

Bottom Channel

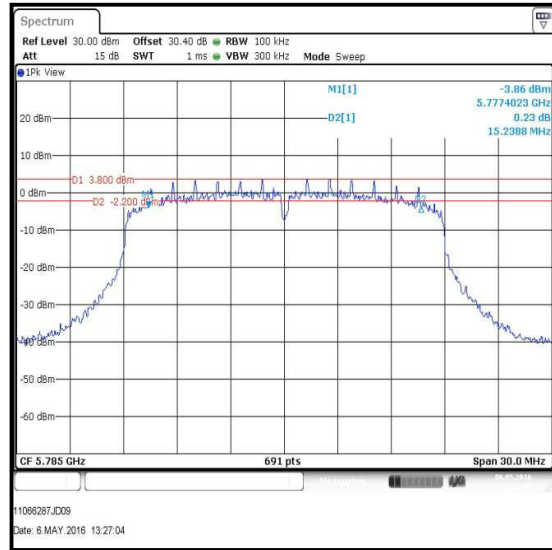

Middle Channel

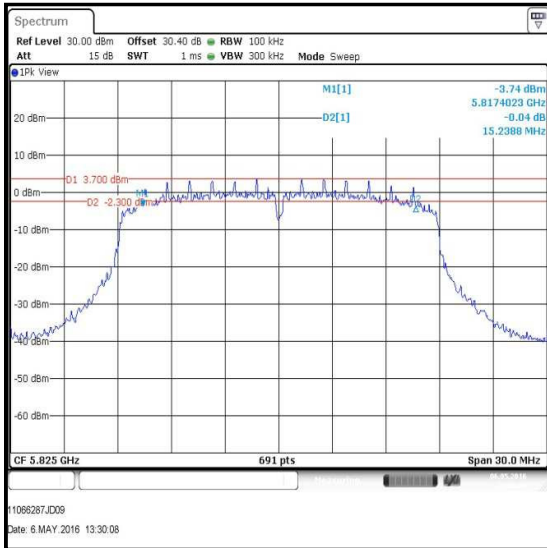

Top Channel

Transmitter Minimum 6 dB Bandwidth (5.725-5.85 GHz band) (continued)

Results: 802.11n / 20 MHz / BPSK / MCS8 / Port 2

Channel	6 dB Bandwidth (kHz)	Limit (kHz)	Margin (kHz)	Result
Bottom	15803	≥500	15303	Complied
Middle	15803	≥500	15303	Complied
Top	15803	≥500	15303	Complied

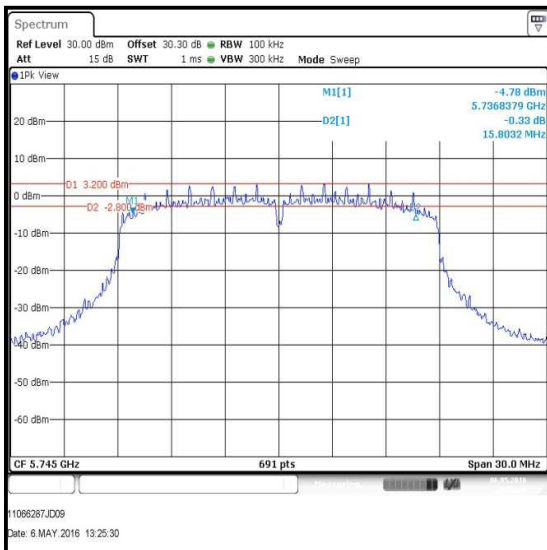

Bottom Channel

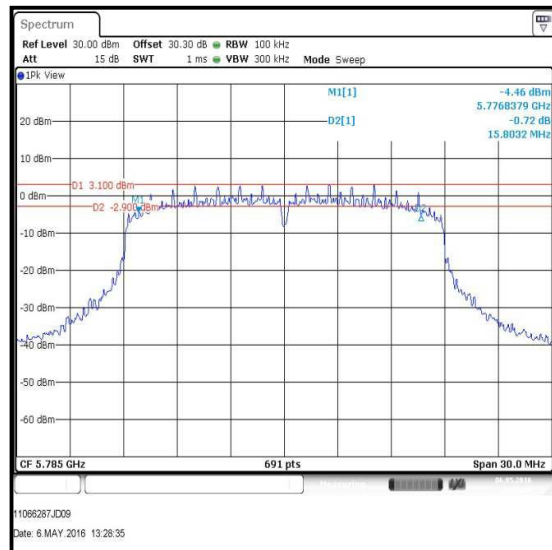

Middle Channel

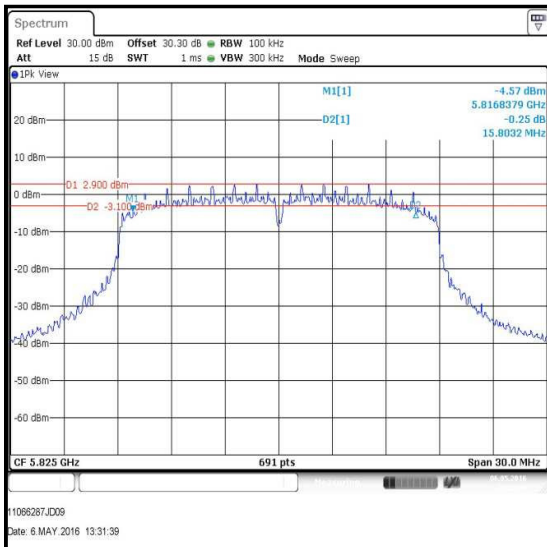

Top Channel

Transmitter Minimum 6 dB Bandwidth (5.725-5.85 GHz band) (continued)

Results: 802.11n / 40 MHz / BPSK / MCS8 / Port 1

Channel	6 dB Bandwidth (kHz)	Limit (kHz)	Margin (kHz)	Result
Bottom	35253	≥500	34753	Complied
Top	35253	≥500	34753	Complied

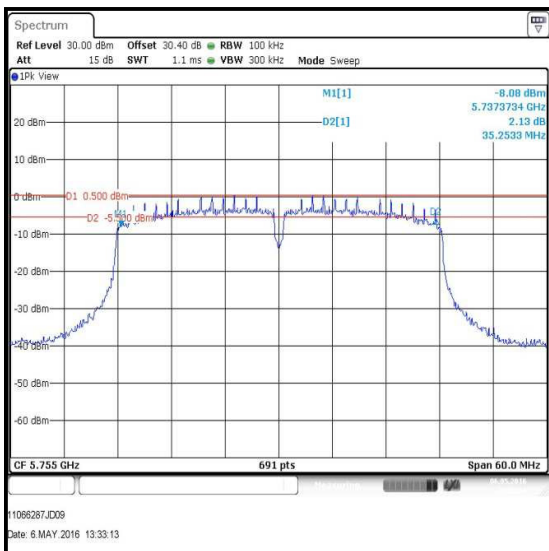

Bottom Channel

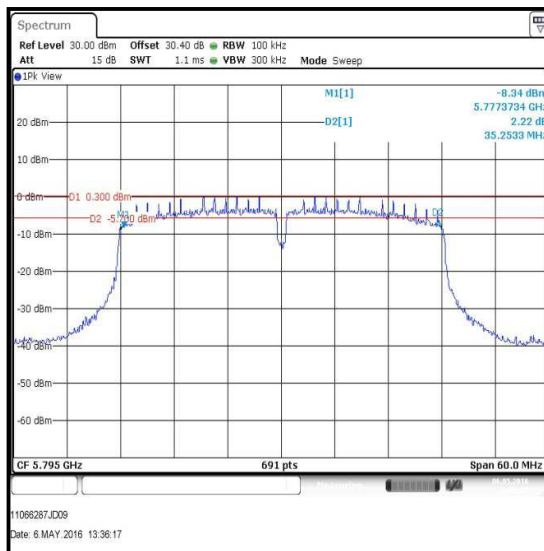

Top Channel

Transmitter Minimum 6 dB Bandwidth (5.725-5.85 GHz band) (continued)

Results: 802.11n / 40 MHz / BPSK / MCS8 / Port 2

Channel	6 dB Bandwidth (kHz)	Limit (kHz)	Margin (kHz)	Result
Bottom	35253	≥500	34753	Complied
Top	35253	≥500	34753	Complied

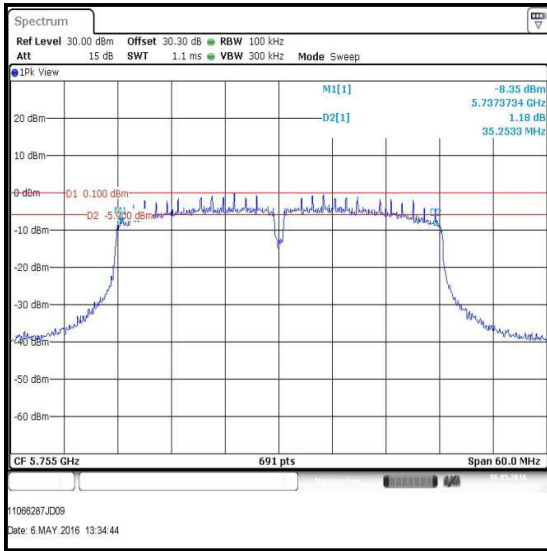

Bottom Channel

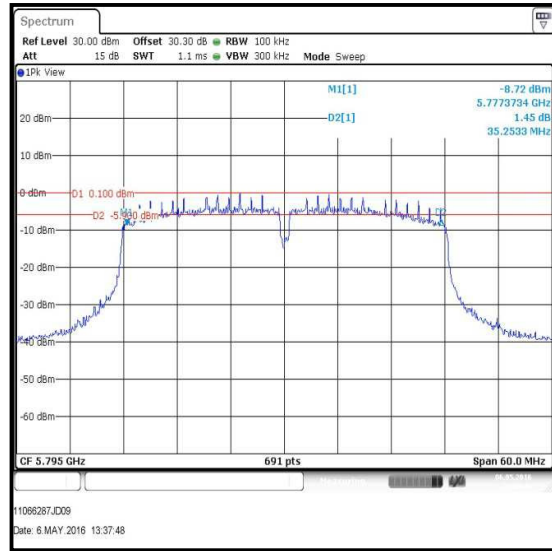

Top Channel

Transmitter Minimum 6 dB Bandwidth (5.725-5.85 GHz band) (continued)

Results: 802.11ac / 80 MHz / BPSK / MCS0x1 / Port 1

Channel	6 dB Bandwidth (kHz)	Limit (kHz)	Margin (kHz)	Result
Single	75369	≥500	74869	Complied

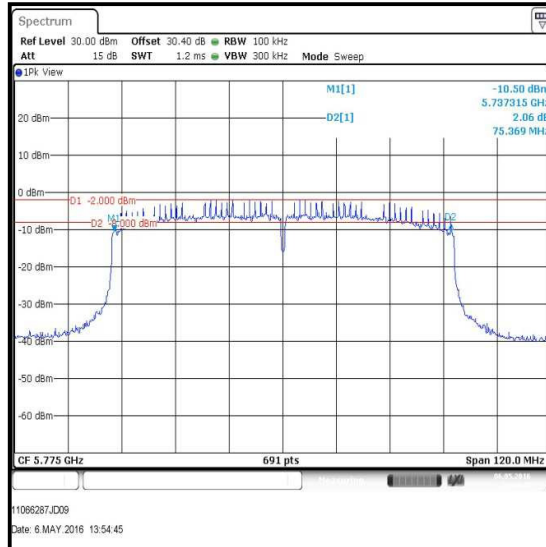

Single Channel

Results: 802.11ac / 80 MHz / BPSK / MCS0x1 / Port 2

Channel	6 dB Bandwidth (kHz)	Limit (kHz)	Margin (kHz)	Result
Single	75369	≥500	74869	Complied

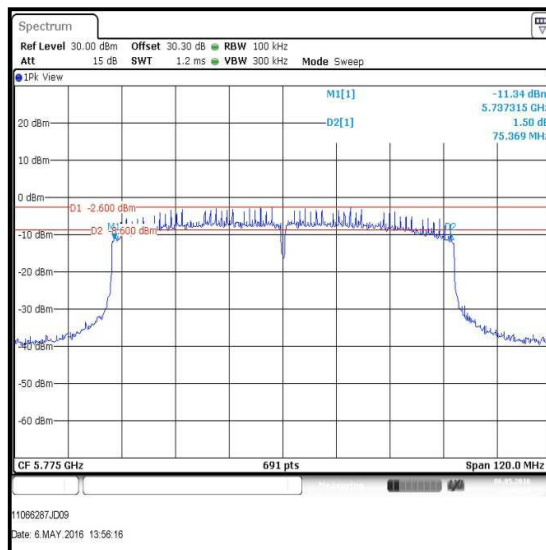

Single Channel

Transmitter Minimum 6 dB Bandwidth (5.725-5.85 GHz band) (continued)**Test Equipment Used:**

Asset No.	Instrument	Manufacturer	Type No.	Serial No.	Date Calibration Due	Cal. Interval (Months)
M2002	Thermohygrometer	Testo	608-H1	45041825	02 Apr 2017	12
M1873	Signal Analyser	Rohde & Schwarz	FSV30	103074	03 Jul 2016	12
M1867	Attenuator	Huber + Suhner AG	6820.17.B	07101	Calibrated before use	-
A2847	Attenuator	Radiall	R411.820.121	24671450	Calibrated before use	-
A2345	Attenuator	Macom	2082-6043-20	None stated	Calibrated before use	-
A2952	RF Switch	Pickering Interfaces	64-102-002 & 40-881-001	XZ340281 & X311198	Calibrated before use	-
S0538	DC Power Supply	TTi	PL154	250135	Calibrated before use	-
M1269	Multimeter	Fluke	175	90250210	13 May 2017	12
M1252	Signal Generator	Hewlett Packard	83640A	3119A00489	26 Oct 2017	24

5.2.4. Transmitter Duty Cycle

Test Summary:

Test Engineer:	Georgios Vrezas	Test Date:	28 April 2016
Test Sample IMEI:	357232070003098		

FCC Reference:	Part 15.35(c)
Test Method Used:	KDB 789033 D02 Section II.B.2.b)

Environmental Conditions:

Temperature (°C):	24
Relative Humidity (%):	28

Note(s):

- In order to assist with the determination of the average level of fundamental and spurious emissions field strength, measurements were made of duty cycle to determine the transmission duration and the silent period time of the transmitter. The transmitter duty cycle was measured using a spectrum analyser in the time domain and calculated by using the following calculation:

$$10 \log 1 / (\text{On Time} / [\text{Period or } 100 \text{ ms whichever is the lesser}]).$$

$$802.11a / 36 \text{ Mbps duty cycle: } 10 \log (1 / (362.598/416.624)) = 0.6 \text{ dB}$$

$$802.11n \text{ HT20} / \text{MCS2 duty cycle: } 10 \log (1 / (660.839/715.684)) = 0.3 \text{ dB}$$

$$802.11n \text{ HT20} / \text{MCS4 duty cycle: } 10 \log (1 / (350.625/404.606)) = 0.6 \text{ dB}$$

$$802.11n \text{ HT40} / \text{MCS0 duty cycle: } 10 \log (1 / (945.300/1000.250)) = 0.2 \text{ dB}$$

$$802.11n \text{ HT40} / \text{MCS5 duty cycle: } 10 \log (1 / (151.318/204.305)) = 1.3 \text{ dB}$$

$$802.11ac \text{ VHT80} / \text{MCS6x1 duty cycle: } 10 \log (1 / (67.727/120.123)) = 2.5 \text{ dB}$$

- Plots below are for data rates with a duty cycle less than 98%. Results for all other modes are archived on the Company server and available for inspection if required.
- The signal analyser was connected to the RF port on the EUT using an RF switch, suitable attenuation and RF cables. An RF level offset was entered on the signal analyser to compensate for the loss of the switch, attenuators and RF cables.

Test setup:

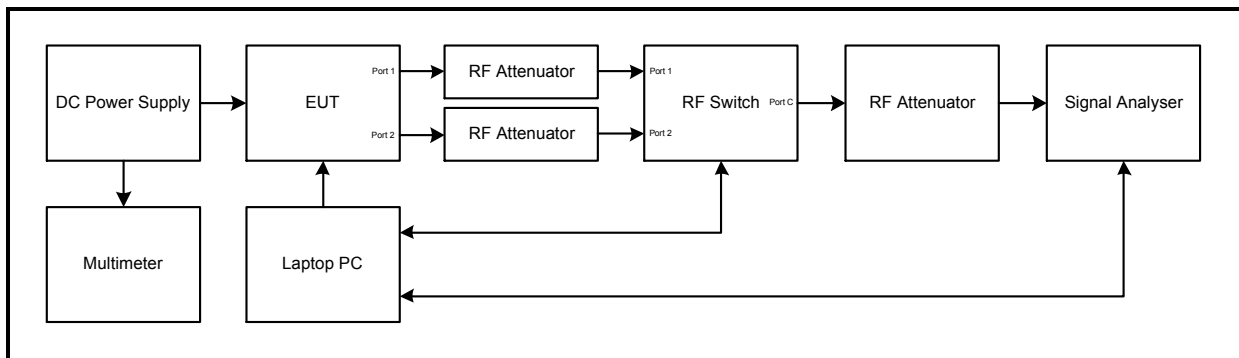

Transmitter Duty Cycle (continued)

Results: 802.11a / 20 MHz / 36 Mbps

Pulse Duration (µs)	Period (µs)	Duty Cycle (dB)
362.598	416.624	0.6

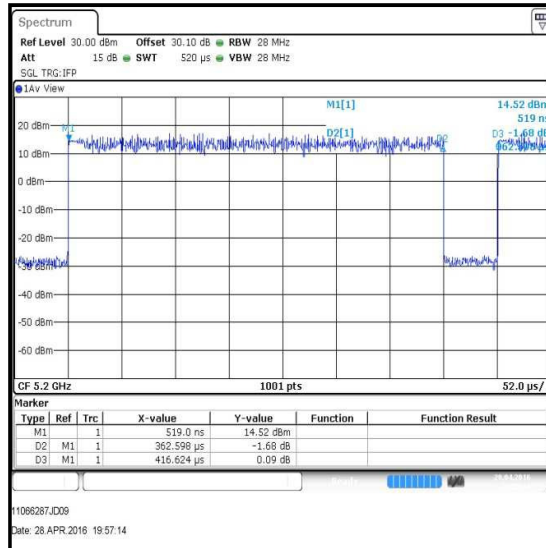

Results: 802.11n / 20 MHz / MCS2

Pulse Duration (µs)	Period (µs)	Duty Cycle (dB)
660.839	715.684	0.3

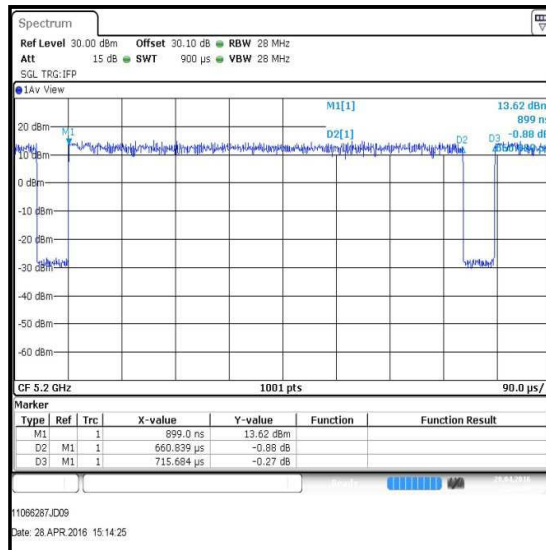

Transmitter Duty Cycle (continued)

Results: 802.11n / 20 MHz / MCS4

Pulse Duration (µs)	Period (µs)	Duty Cycle (dB)
350.625	404.606	0.6

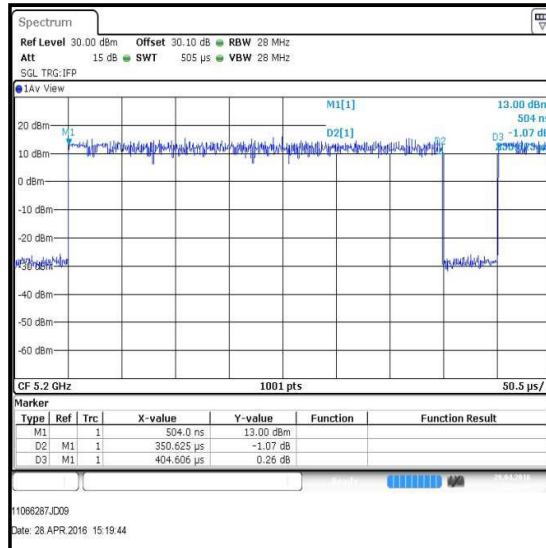

Results: 802.11n / 40 MHz / MCS0

Pulse Duration (µs)	Period (µs)	Duty Cycle (dB)
945.300	1000.250	0.2

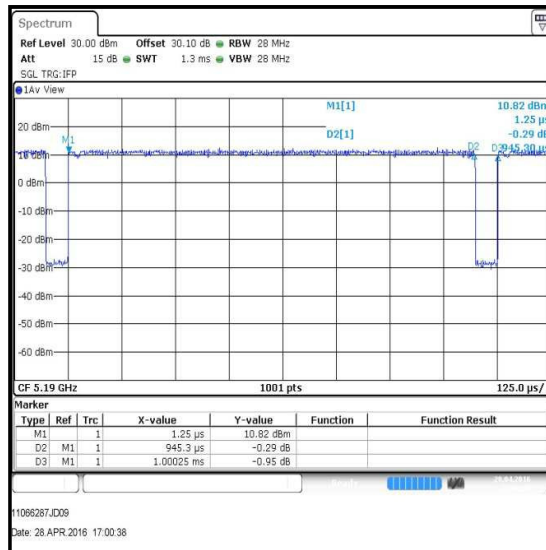

Transmitter Duty Cycle (continued)

Results: 802.11n / 40 MHz / MCS5

Pulse Duration (µs)	Period (µs)	Duty Cycle (dB)
151.318	204.305	1.3

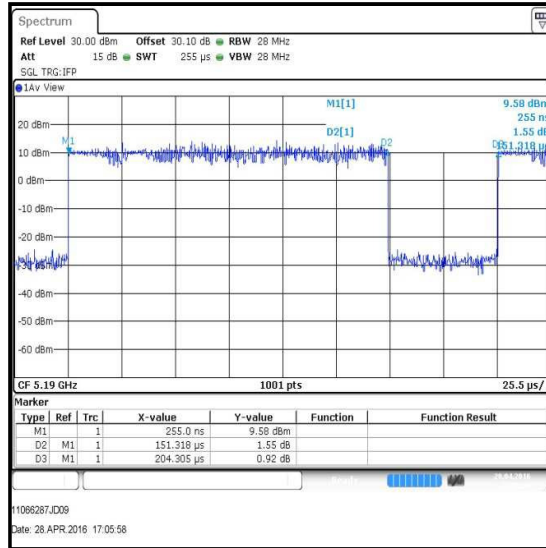

Results: 802.11ac / 80 MHz / MCS6x1

Pulse Duration (µs)	Period (µs)	Duty Cycle (dB)
67.727	120.123	2.5

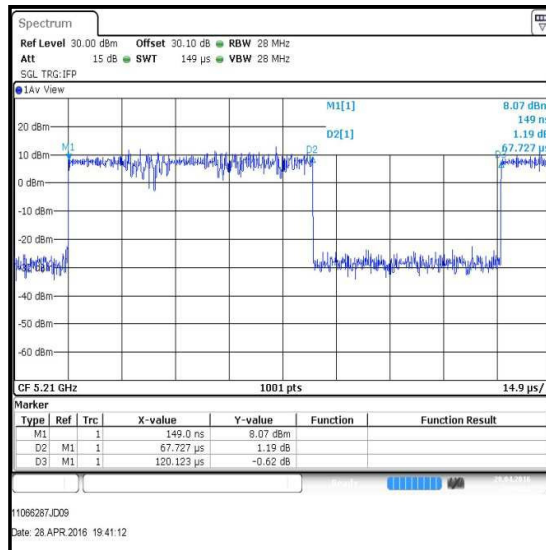

Transmitter Duty Cycle (continued)**Test Equipment Used:**

Asset No.	Instrument	Manufacturer	Type No.	Serial No.	Date Calibration Due	Cal. Interval (Months)
M2002	Thermohygrometer	Testo	608-H1	45041825	02 Apr 2017	12
M1873	Signal Analyser	Rohde & Schwarz	FSV30	103074	03 Jul 2016	12
M1867	Attenuator	Huber + Suhner AG	6820.17.B	07101	Calibrated before use	-
A2847	Attenuator	Radiall	R411.820.121	24671450	Calibrated before use	-
A2345	Attenuator	Macom	2082-6043-20	None stated	Calibrated before use	-
A2952	RF Switch	Pickering Interfaces	64-102-002 & 40-881-001	XZ340281 & X311198	Calibrated before use	-
S0538	DC Power Supply	TTi	PL154	250135	Calibrated before use	-
M1269	Multimeter	Fluke	175	90250210	13 May 2017	12
M1252	Signal Generator	Hewlett Packard	83640A	3119A00489	26 Oct 2017	24

5.2.5. Transmitter Maximum Conducted Output Power

Test Summary:

Test Engineer:	Georgios Vrezas	Test Date:	28 April 2016
Test Sample IMEI:	357232070003098		

FCC Reference:	Part 15.407(a)(1)(iv)
Test Method Used:	KDB 789033 D02 Section II.E.2.d)

Environmental Conditions:

Temperature (°C):	24
Relative Humidity (%):	28

Note(s):

- All supported modes and channel widths were initially investigated on one channel. The modes that produced the highest power and therefore deemed worst case were:
 - 802.11a – 16QAM / 36 Mbps
 - 802.11n HT20 – 16QAM / 39 Mbps / MCS4
 - 802.11n HT40 – BPSK / 13.5 Mbps / MCS0
 - 802.11ac VHT80 – 64QAM / 263.3 Mbps / MCS6x1

Measurements were then performed in these modes on bottom, middle and top channels in all operating bands.

- Testing was performed in accordance with KDB 789033 Section II.E.2.d) Method SA-2. The signal analyser's integration function was used to integrate across the 26 dB emission bandwidth. The signal analyser resolution bandwidth was set to 1 MHz and video bandwidth 3 MHz. An RMS detector was used and sweep time set manually to perform trace averaging over 300 traces. The span was set to encompass the EBW. The calculated duty cycle in section 5.2.4 was added to the measured power in order to compute the average power during the actual transmission time.
- Power was measured on both ports and then combined using the measure-and-sum technique stated in FCC KDB 662911 D01 Section E)1).
- For 802.11ac with 2 spatial streams, the EUT uses spatial multiplexing, with unequal antenna gains and each transmit antenna driven by only one spatial stream. The directional antenna gain has been calculated in accordance with KDB 662911 D01 Section F)2)e)(ii):

$$\begin{aligned}
 \text{Directional Gain} &= 10 \log \left[\frac{\sum_{j=1}^{N_{SS}} \left(\sum_{k=1}^{N_{ANT}} g_{j,k} \right)^2}{N_{ANT}} \right] = 10 \log \left[n \frac{\sum_{j=1}^2 \left(\sum_{k=1}^2 g_{j,k} \right)^2}{2} \right] = \\
 &= 10 \log \left[\frac{(g_{1,1} + g_{1,2})^2 + (g_{2,1} + g_{2,2})^2}{2} \right] = 10 \log \left[\frac{(g_{1,1})^2 + (g_{2,2})^2}{2} \right] = \\
 &= 10 \log \left[\frac{\left(10^{\frac{G_1}{20}} \right)^2 + \left(10^{\frac{G_2}{20}} \right)^2}{2} \right] = 10 \log \left[\frac{\left(10^{\frac{-0.11}{20}} \right)^2 + \left(10^{\frac{-0.3}{20}} \right)^2}{2} \right] = -0.2 \text{ dBi}
 \end{aligned}$$

Transmitter Maximum Conducted Output Power (5.15-5.25 GHz band) (continued)**Note(s) continued:**

4. For all other modes of operation, the directional antenna gain has been calculated in accordance with KDB 662911 D01 Section F)2)f)(ii):

$$\begin{aligned} \text{Directional Gain} &= 10 \log \left[\frac{\sum_{j=1}^{N_{SS}} \left(\sum_{k=1}^{N_{ANT}} g_{j,k} \right)^2}{N_{ANT}} \right] = 10 \log \left[\frac{\sum_{j=1}^1 \left(\sum_{k=1}^2 g_{j,k} \right)^2}{2} \right] = \\ &= 10 \log \left[\frac{(g_{1,1} + g_{1,2})^2}{2} \right] = 10 \log \left[\frac{\left(10^{\frac{G_1}{20}} + 10^{\frac{G_2}{20}} \right)^2}{2} \right] = 10 \log \left[\frac{\left(10^{\frac{-0.11}{20}} + 10^{\frac{-0.3}{20}} \right)^2}{2} \right] = 2.8 \text{ dBi} \end{aligned}$$

5. The EUT has a directional antenna gain of <6 dBi.
6. The signal analyser was connected to the RF port on the EUT using an RF switch, suitable attenuation and RF cables. An RF level offset was entered on the signal analyser to compensate for the loss of the switch, attenuators and RF cables.
7. The Part 15.407(a)(1)(iv) limit shall not exceed 250 mW (24.0 dBm).

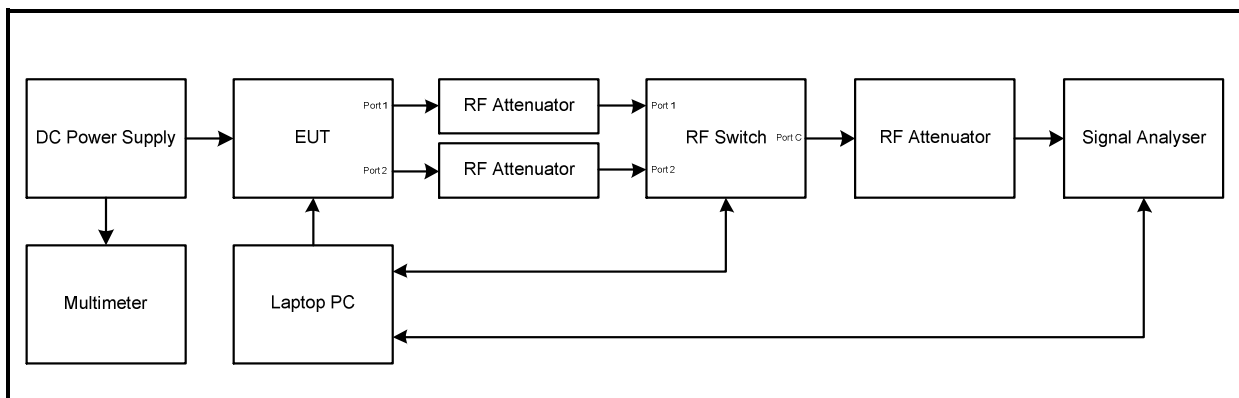
Test setup:

Transmitter Maximum Conducted Output Power (5.15-5.25 GHz band) (continued)**Results: 802.11a / 20 MHz / 16QAM / 36 Mbps**

Channel	Frequency (MHz)	Port 1			Port 2		
		Conducted Peak Power (dBm)	Duty Cycle Correction (dB)	Corrected Conducted Peak Power (dBm)	Conducted Peak Power (dBm)	Duty Cycle Correction (dB)	Corrected Conducted Peak Power (dBm)
Bottom	5180	14.3	0.6	14.9	14.4	0.6	15.0
Middle	5200	14.3	0.6	14.9	14.3	0.6	14.9
Top	5240	14.2	0.6	14.8	14.1	0.6	14.7

Channel	Frequency (MHz)	Corrected Conducted Peak Power Port 1 (dBm)	Corrected Conducted Peak Power Port 2 (dBm)	Combined Conducted Power (dBm)	Limit (dBm)	Margin (dB)	Result
Bottom	5180	14.9	15.0	18.0	24.0	6.0	Complied
Middle	5200	14.9	14.9	17.9	24.0	6.1	Complied
Top	5240	14.8	14.7	17.8	24.0	6.2	Complied

Transmitter Maximum Conducted Output Power (5.15-5.25 GHz band) (continued)

Results: 802.11a / 20 MHz / 16QAM / 36 Mbps / Port 1

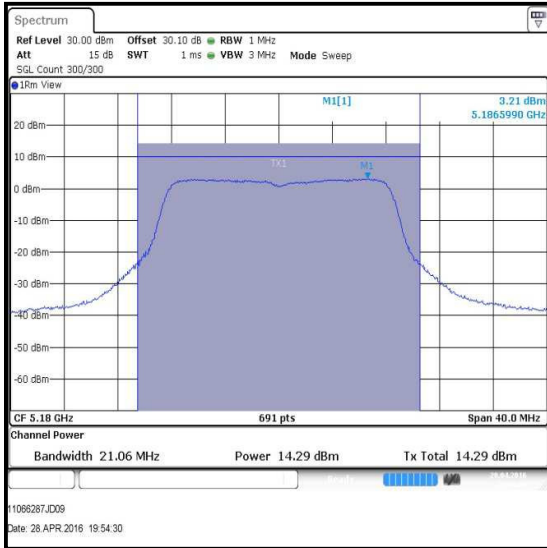

Bottom Channel

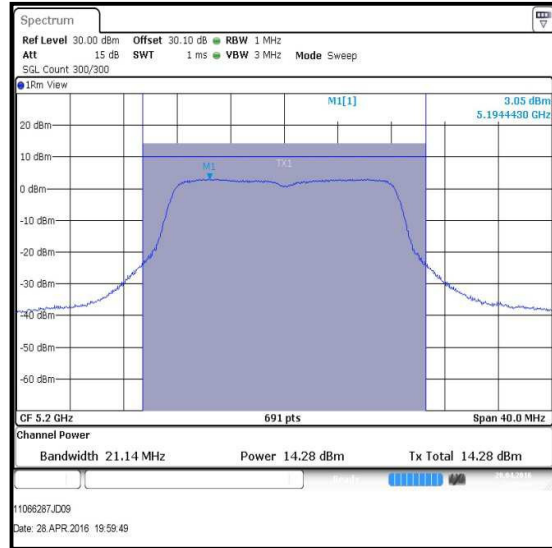

Middle Channel

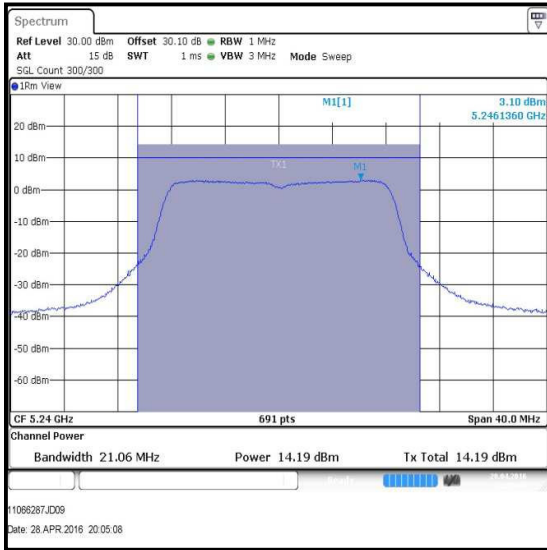

Top Channel

Transmitter Maximum Conducted Output Power (5.15-5.25 GHz band) (continued)

Results: 802.11a / 20 MHz / 16QAM / 36 Mbps / Port 2

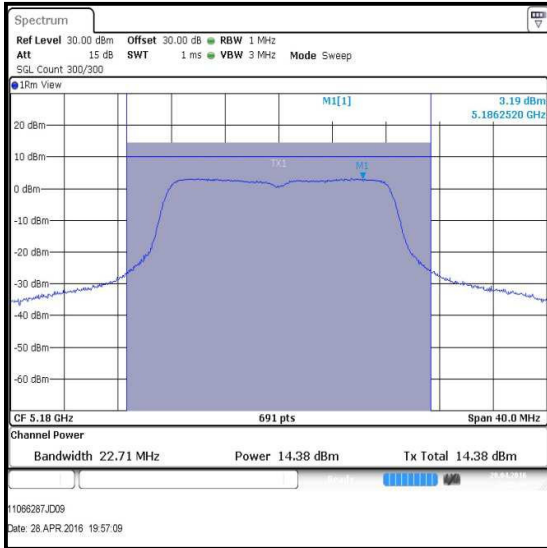

Bottom Channel

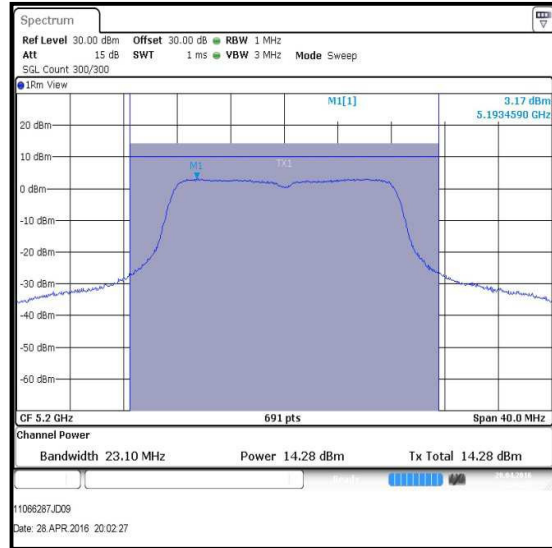

Middle Channel

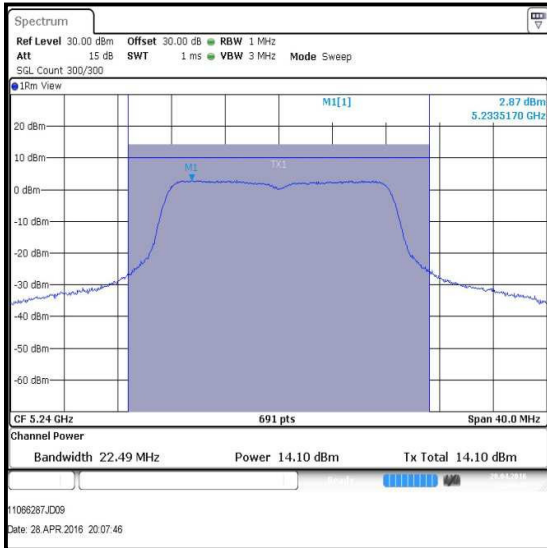

Top Channel

Transmitter Maximum Conducted Output Power (5.15-5.25 GHz band) (continued)**Results: 802.11n / 20 MHz / 16QAM / MCS4**

Channel	Frequency (MHz)	Port 1			Port 2		
		Conducted Peak Power (dBm)	Duty Cycle Correction (dB)	Corrected Conducted Peak Power (dBm)	Conducted Peak Power (dBm)	Duty Cycle Correction (dB)	Corrected Conducted Peak Power (dBm)
Bottom	5180	13.0	0.6	13.6	12.9	0.6	13.5
Middle	5200	12.9	0.6	13.5	12.8	0.6	13.4
Top	5240	12.8	0.6	13.4	12.5	0.6	13.1

Channel	Frequency (MHz)	Corrected Conducted Peak Power Port 1 (dBm)	Corrected Conducted Peak Power Port 2 (dBm)	Combined Conducted Power (dBm)	Limit (dBm)	Margin (dB)	Result
Bottom	5180	13.6	13.5	16.6	24.0	7.4	Complied
Middle	5200	13.5	13.4	16.5	24.0	7.5	Complied
Top	5240	13.4	13.1	16.3	24.0	7.7	Complied

Transmitter Maximum Conducted Output Power (5.15-5.25 GHz band) (continued)

Results: 802.11n / 20 MHz / 16QAM / MCS4 / Port 1

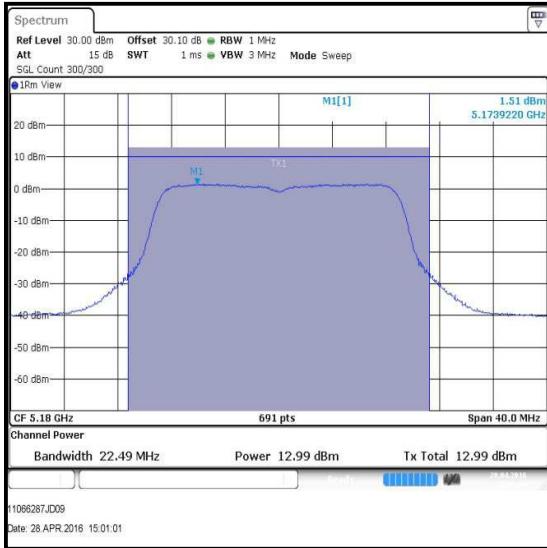

Bottom Channel

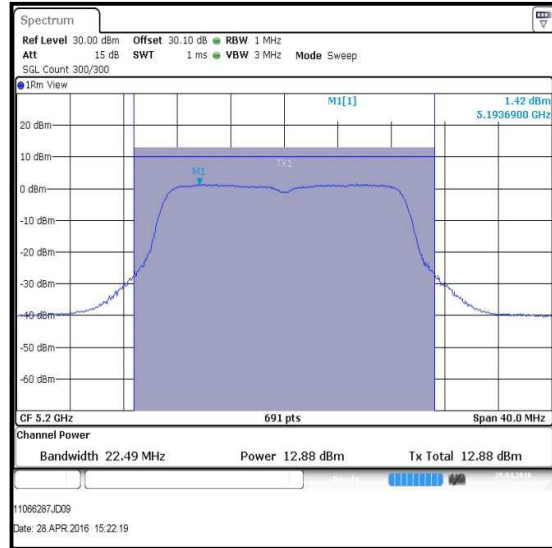

Middle Channel

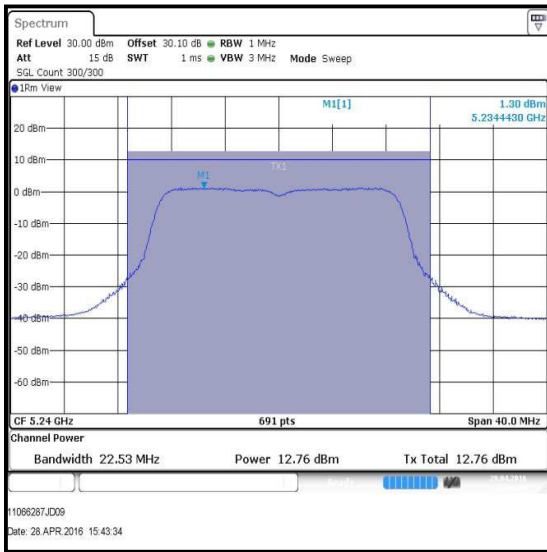

Top Channel

Transmitter Maximum Conducted Output Power (5.15-5.25 GHz band) (continued)

Results: 802.11n / 20 MHz / 16QAM / MCS4 / Port 2

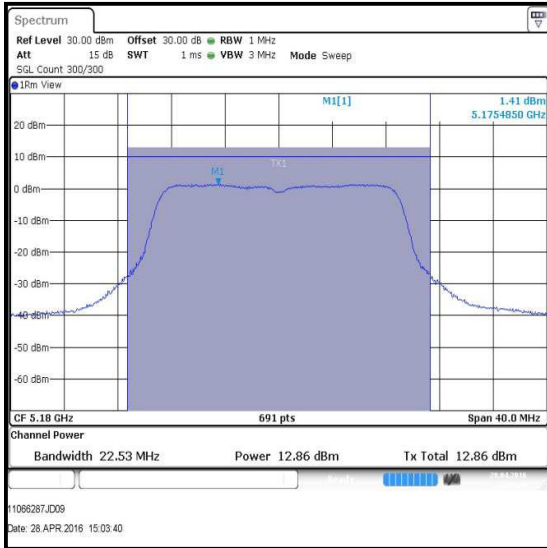

Bottom Channel

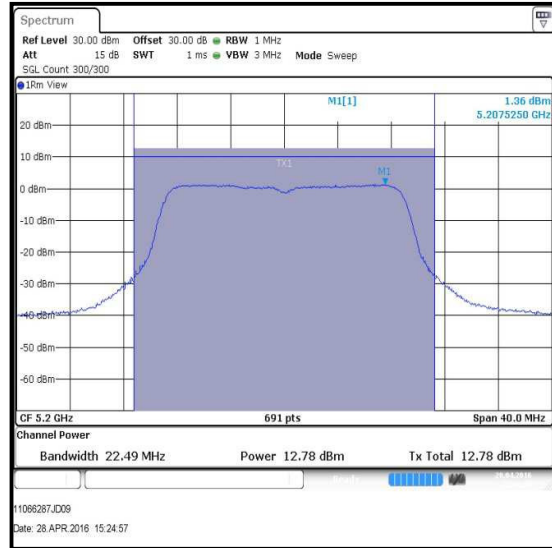

Middle Channel

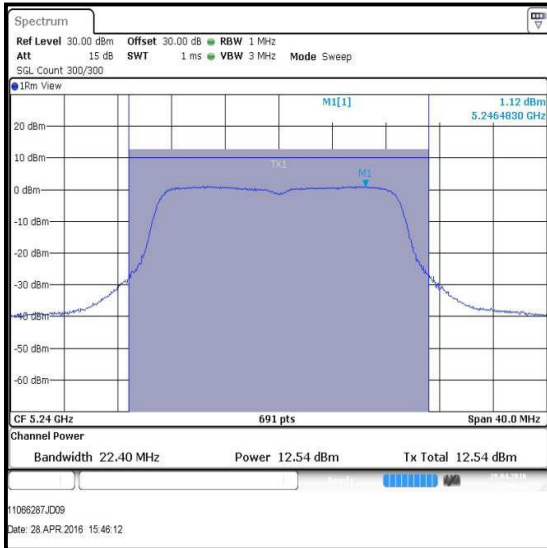

Top Channel

Transmitter Maximum Conducted Output Power (5.15-5.25 GHz band) (continued)**Results: 802.11n / 40 MHz / BPSK / MCS0**

Channel	Frequency (MHz)	Port 1			Port 2		
		Conducted Peak Power (dBm)	Duty Cycle Correction (dB)	Corrected Conducted Peak Power (dBm)	Conducted Peak Power (dBm)	Duty Cycle Correction (dB)	Corrected Conducted Peak Power (dBm)
Bottom	5190	12.6	0.2	12.8	12.6	0.2	12.8
Top	5230	12.5	0.2	12.7	12.3	0.2	12.5

Channel	Frequency (MHz)	Corrected Conducted Peak Power Port 1 (dBm)	Corrected Conducted Peak Power Port 2 (dBm)	Combined Conducted Power (dBm)	Limit (dBm)	Margin (dB)	Result
Bottom	5190	12.8	12.8	15.8	24.0	8.2	Complied
Top	5230	12.7	12.5	15.6	24.0	8.4	Complied

Transmitter Maximum Conducted Output Power (5.15-5.25 GHz band) (continued)

Results: 802.11n / 40 MHz / BPSK / MCS0 / Port 1

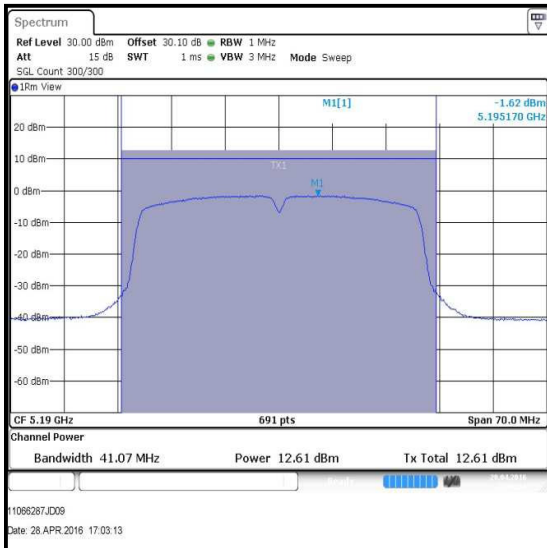

Bottom Channel

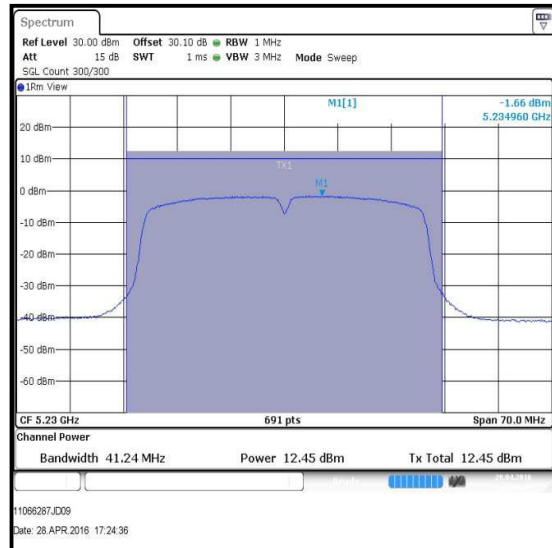

Top Channel

Results: 802.11n / 40 MHz / BPSK / MCS0 / Port 2

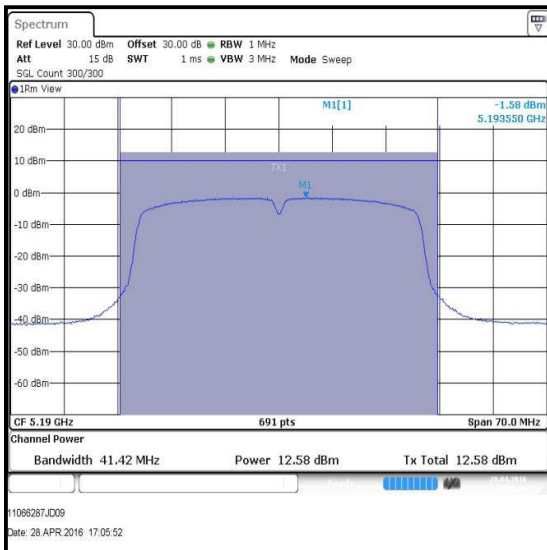

Bottom Channel

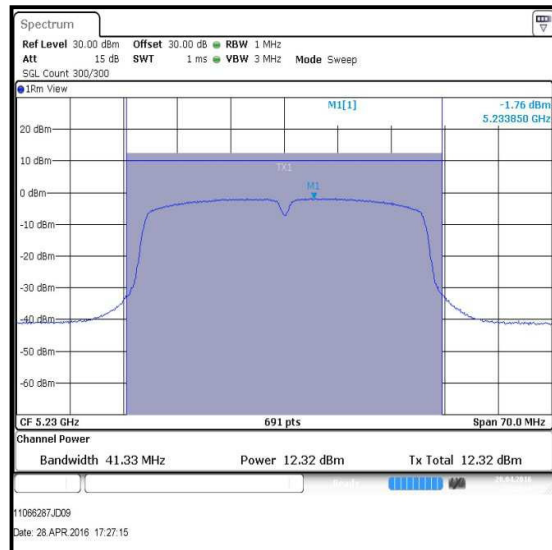

Top Channel

Transmitter Maximum Conducted Output Power (5.15-5.25 GHz band) (continued)**Results: 802.11ac / 80 MHz / 64QAM / MCS6x1**

Channel	Frequency (MHz)	Port 1			Port 2		
		Conducted Peak Power (dBm)	Duty Cycle Correction (dB)	Corrected Conducted Peak Power (dBm)	Conducted Peak Power (dBm)	Duty Cycle Correction (dB)	Corrected Conducted Peak Power (dBm)
Single	5210	11.0	2.5	13.5	10.9	2.5	13.4

Channel	Frequency (MHz)	Corrected Conducted Peak Power Port 1 (dBm)	Corrected Conducted Peak Power Port 2 (dBm)	Combined Conducted Power (dBm)	Limit (dBm)	Margin (dB)	Result
Single	5210	13.5	13.4	16.5	24.0	7.5	Complied

Transmitter Maximum Conducted Output Power (5.15-5.25 GHz band) (continued)

Results: 802.11ac / 80 MHz / 64QAM / MCS6x1 / Port 1

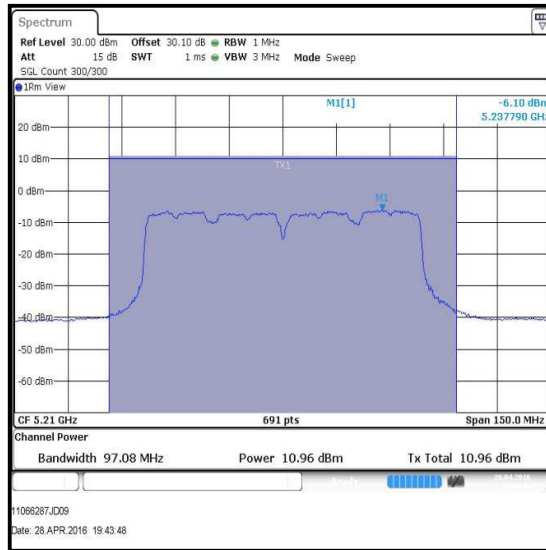

Single Channel

Results: 802.11ac / 80 MHz / 64QAM / MCS6x1 / Port 2

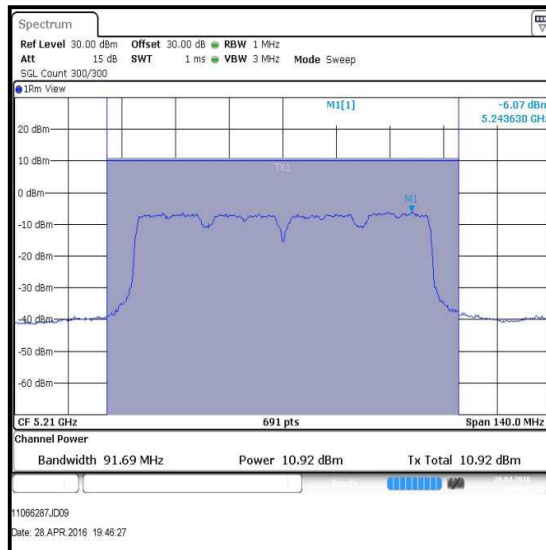

Single Channel

Transmitter Maximum Conducted Output Power (5.25-5.35 GHz & 5.47-5.725 GHz bands)**Test Summary:**

Test Engineer:	Georgios Vrezas	Test Dates:	28 April 2016 to 17 June 2016
Test Sample IMEI:	357232070003098		

FCC Reference:	Part 15.407(a)(2)
Test Method Used:	KDB 789033 D02 Section II.E.2.d)

Environmental Conditions:

Temperature (°C):	23 to 26
Relative Humidity (%):	28 to 48

Note(s):

- The FCC Part 15.407(a)(2) limit is the lesser of 250 mW (24.0 dBm) or $11 \text{ dBm} + 10 \log_{10} B$, where B is the previously measured 26 dB emission bandwidth in MHz. For both U-NII-2A and U-NII-2C bands, the 26 dB EBW is greater than 20 MHz.

$$\begin{aligned}
 &\text{For } B > 20 \text{ MHz} \rightarrow \\
 &\rightarrow \log_{10} B > \log_{10} 20 \rightarrow \\
 &\rightarrow 10 \log_{10} B > 10 \log_{10} 20 \rightarrow \\
 &\rightarrow 11 + 10 \log_{10} B > 11 + 10 \log_{10} 20 \rightarrow \\
 &\rightarrow 11 + 10 \log_{10} B > 24.0 \text{ dBm}
 \end{aligned}$$

Therefore for measured emission bandwidths greater than 20 MHz, the lesser of the two limits is the fixed limit of 250 mW (24.0 dBm). This was applied to the results.

- The EUT has a directional antenna gain of <6 dBi.

**Transmitter Maximum Conducted Output Power (5.25-5.35 GHz & 5.47-5.725 GHz bands)
(continued)**

Results: 802.11a / 20 MHz / 16QAM / 36 Mbps / 5.25-5.35 GHz band

Channel	Frequency (MHz)	Port 1			Port 2		
		Conducted Peak Power (dBm)	Duty Cycle Correction (dB)	Corrected Conducted Peak Power (dBm)	Conducted Peak Power (dBm)	Duty Cycle Correction (dB)	Corrected Conducted Peak Power (dBm)
Bottom	5260	14.2	0.6	14.8	14.3	0.6	14.9
Middle	5280	14.2	0.6	14.8	14.2	0.6	14.8
Top	5320	14.0	0.6	14.6	13.9	0.6	14.5

Channel	Frequency (MHz)	Corrected Conducted Peak Power Port 1 (dBm)	Corrected Conducted Peak Power Port 2 (dBm)	Combined Conducted Power (dBm)	Limit (dBm)	Margin (dB)	Result
Bottom	5260	14.8	14.9	17.9	24.0	6.1	Complied
Middle	5280	14.8	14.8	17.8	24.0	6.2	Complied
Top	5320	14.6	14.5	17.6	24.0	6.4	Complied

**Transmitter Maximum Conducted Output Power (5.25-5.35 GHz & 5.47-5.725 GHz bands)
(continued)**

Results: 802.11a / 20 MHz / 16QAM / 36 Mbps / 5.25-5.35 GHz band / Port 1

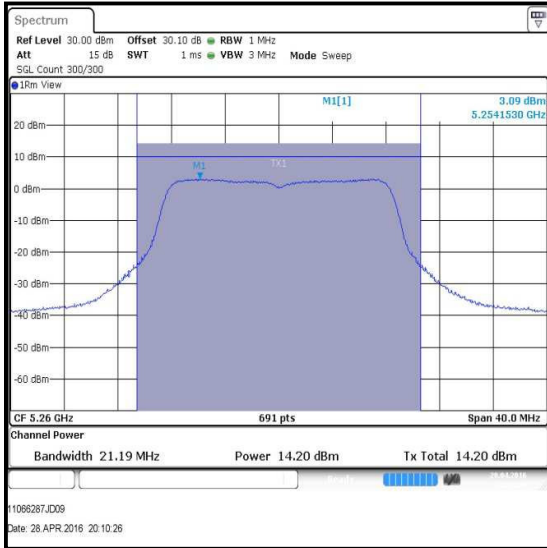

Bottom Channel

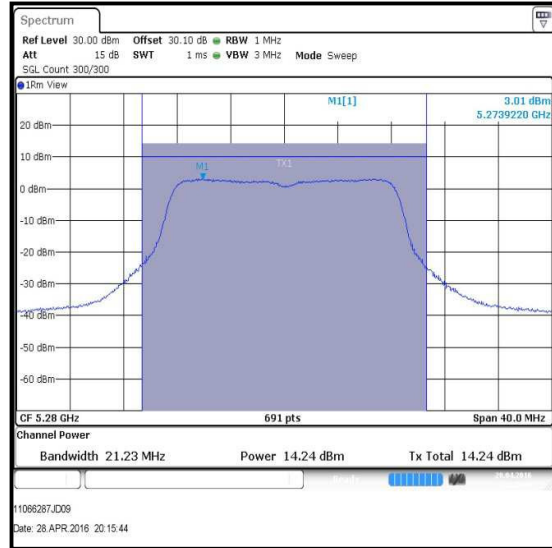

Middle Channel

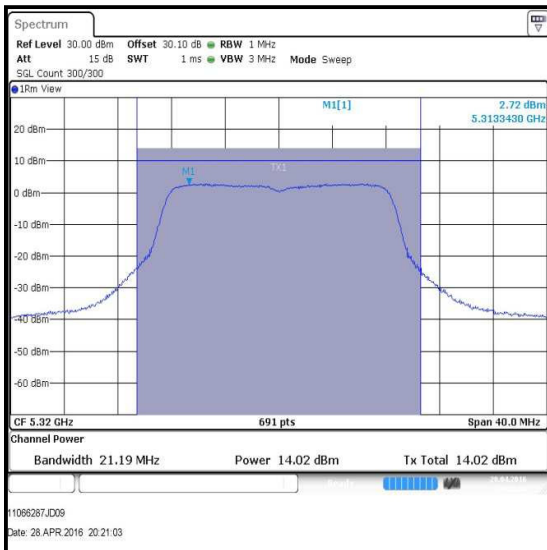

Top Channel

**Transmitter Maximum Conducted Output Power (5.25-5.35 GHz & 5.47-5.725 GHz bands)
(continued)**

Results: 802.11a / 20 MHz / 16QAM / 36 Mbps / 5.25-5.35 GHz band / Port 2

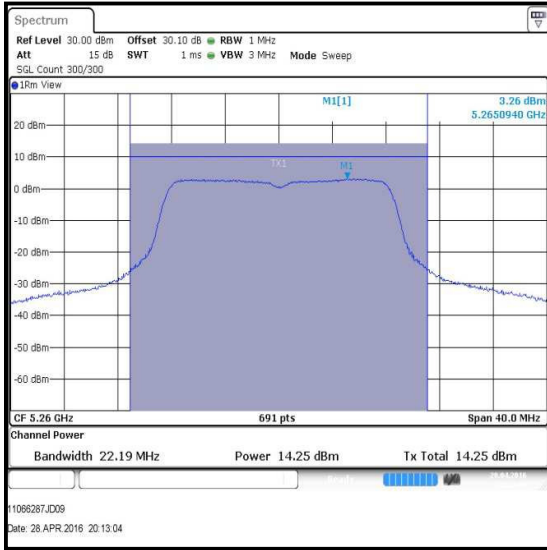

Bottom Channel

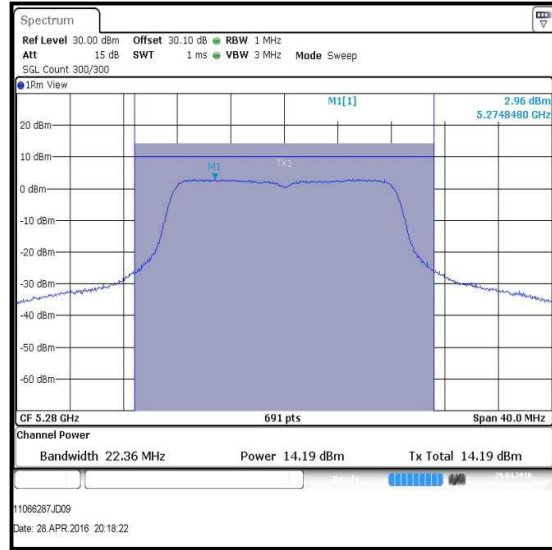

Middle Channel

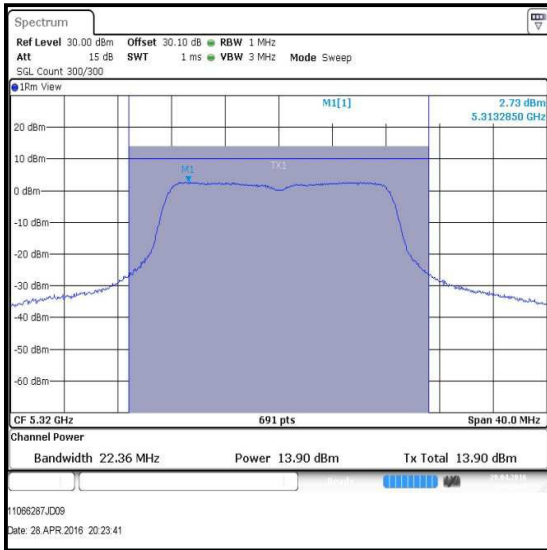

Top Channel

Transmitter Maximum Conducted Output Power (5.25-5.35 GHz & 5.47-5.725 GHz bands)
(continued)

Results: 802.11n / 20 MHz / 16QAM / MCS4 / 5.25-5.35 GHz band

Channel	Frequency (MHz)	Port 1			Port 2		
		Conducted Peak Power (dBm)	Duty Cycle Correction (dB)	Corrected Conducted Peak Power (dBm)	Conducted Peak Power (dBm)	Duty Cycle Correction (dB)	Corrected Conducted Peak Power (dBm)
Bottom	5260	12.7	0.6	13.3	12.6	0.6	13.2
Middle	5280	12.6	0.6	13.2	12.5	0.6	13.1
Top	5320	12.4	0.6	13.0	12.2	0.6	12.8

Channel	Frequency (MHz)	Corrected Conducted Peak Power Port 1 (dBm)	Corrected Conducted Peak Power Port 2 (dBm)	Combined Conducted Power (dBm)	Limit (dBm)	Margin (dB)	Result
Bottom	5260	13.3	13.2	16.3	24.0	7.7	Complied
Middle	5280	13.2	13.1	16.2	24.0	7.8	Complied
Top	5320	13.0	12.8	15.9	24.0	8.1	Complied

**Transmitter Maximum Conducted Output Power (5.25-5.35 GHz & 5.47-5.725 GHz bands)
(continued)**

Results: 802.11n / 20 MHz / 16QAM / 5.25-5.35 GHz band / Port 1

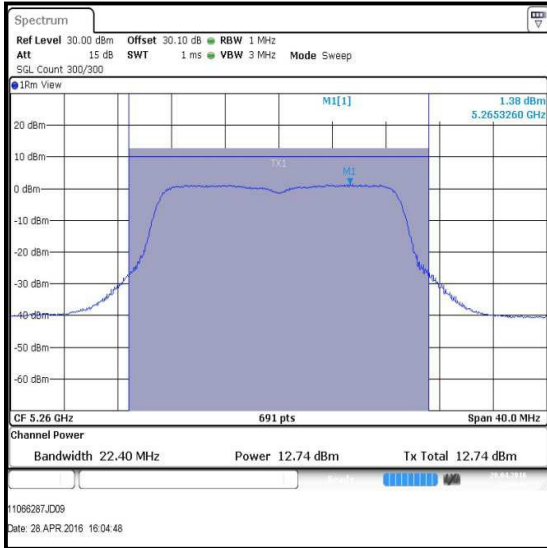

Bottom Channel

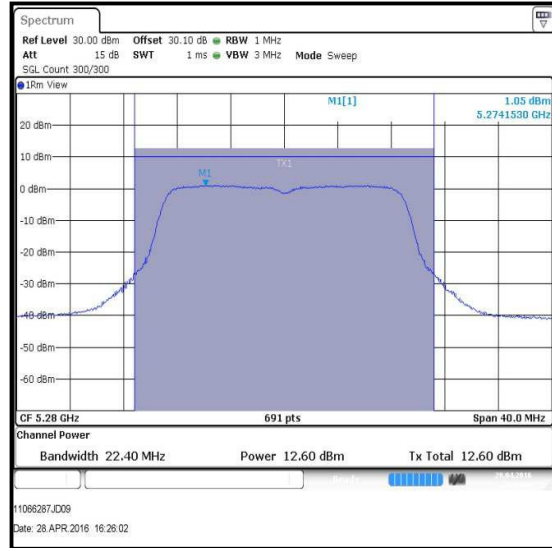

Middle Channel

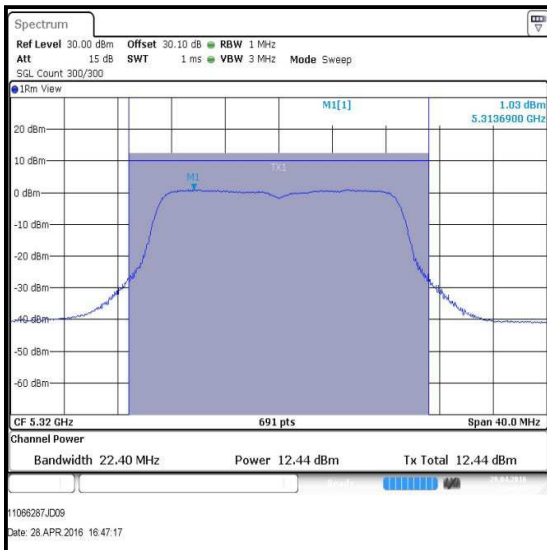

Top Channel

**Transmitter Maximum Conducted Output Power (5.25-5.35 GHz & 5.47-5.725 GHz bands)
(continued)**

Results: 802.11n / 20 MHz / 16QAM / MCS4 / 5.25-5.35 GHz band / Port 2

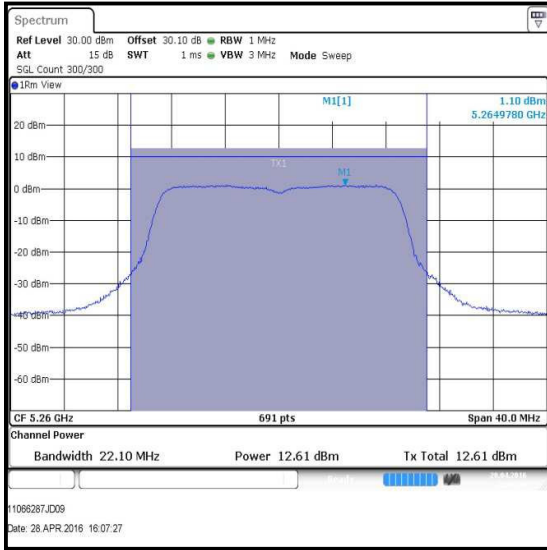

Bottom Channel

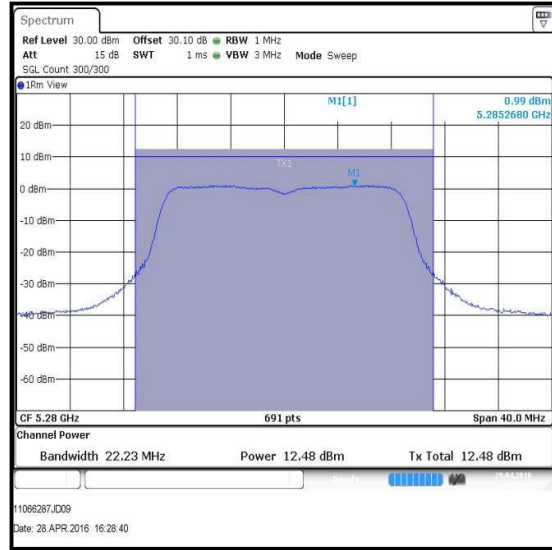

Middle Channel

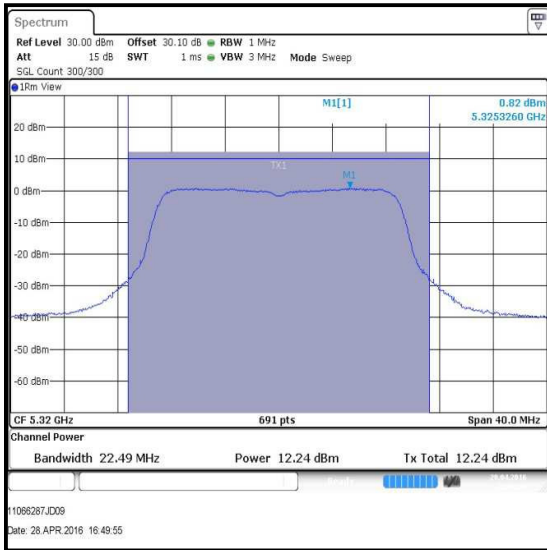

Top Channel

Transmitter Maximum Conducted Output Power (5.25-5.35 GHz & 5.47-5.725 GHz bands)
(continued)

Results: 802.11n / 40 MHz / BPSK / MCS0 / 5.25-5.35 GHz band

Channel	Frequency (MHz)	Port 1			Port 2		
		Conducted Peak Power (dBm)	Duty Cycle Correction (dB)	Corrected Conducted Peak Power (dBm)	Conducted Peak Power (dBm)	Duty Cycle Correction (dB)	Corrected Conducted Peak Power (dBm)
Bottom	5270	13.1	0.2	13.3	13.0	0.2	13.2
Top	5310	12.9	0.2	13.1	12.8	0.2	13.0

Channel	Frequency (MHz)	Corrected Conducted Peak Power Port 1 (dBm)	Corrected Conducted Peak Power Port 2 (dBm)	Combined Conducted Power (dBm)	Limit (dBm)	Margin (dB)	Result
Bottom	5270	13.3	13.2	16.3	24.0	7.7	Complied
Top	5310	13.1	13.0	16.1	24.0	7.9	Complied

**Transmitter Maximum Conducted Output Power (5.25-5.35 GHz & 5.47-5.725 GHz bands)
(continued)**

Results: 802.11n / 40 MHz / BPSK / MCS0 / 5.25-5.35 GHz band / Port 1

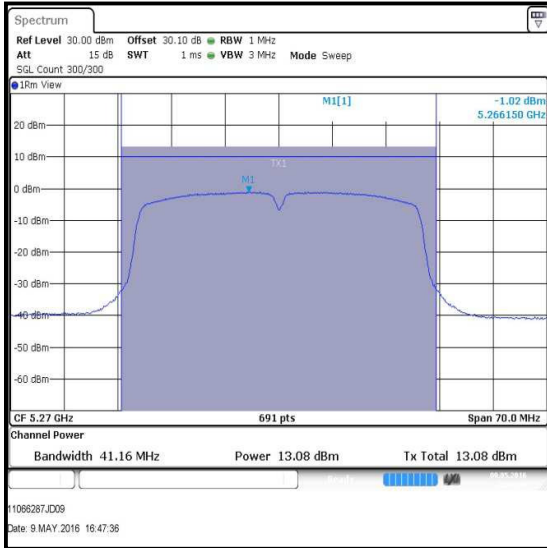

Bottom Channel

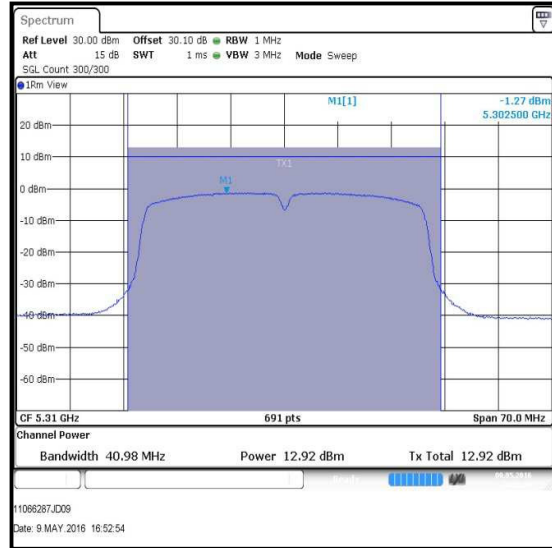

Top Channel

Results: 802.11n / 40 MHz / BPSK / MCS0 / 5.25-5.35 GHz band / Port 2

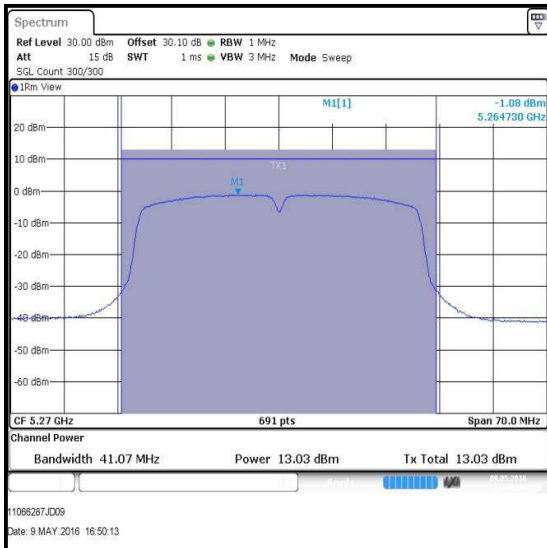

Bottom Channel

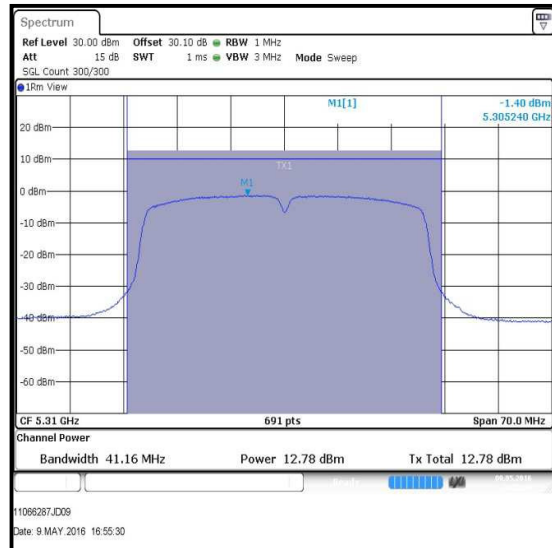

Top Channel

Transmitter Maximum Conducted Output Power (5.25-5.35 GHz & 5.47-5.725 GHz bands)
(continued)

Results: 802.11ac / 80 MHz / 64QAM / MCS6x1 / 5.25-5.35 GHz band

Channel	Frequency (MHz)	Port 1			Port 2		
		Conducted Peak Power (dBm)	Duty Cycle Correction (dB)	Corrected Conducted Peak Power (dBm)	Conducted Peak Power (dBm)	Duty Cycle Correction (dB)	Corrected Conducted Peak Power (dBm)
Single	5290	10.9	2.5	13.4	10.8	2.5	13.3

Channel	Frequency (MHz)	Corrected Conducted Peak Power Port 1 (dBm)	Corrected Conducted Peak Power Port 2 (dBm)	Combined Conducted Power (dBm)	Limit (dBm)	Margin (dB)	Result
Single	5290	13.4	13.3	16.4	24.0	7.6	Complied

Transmitter Maximum Conducted Output Power (5.25-5.35 GHz & 5.47-5.725 GHz bands)
(continued)

Results: 802.11ac / 80 MHz / 64QAM / MCS6x1 / 5.25-5.35 GHz band / Port 1

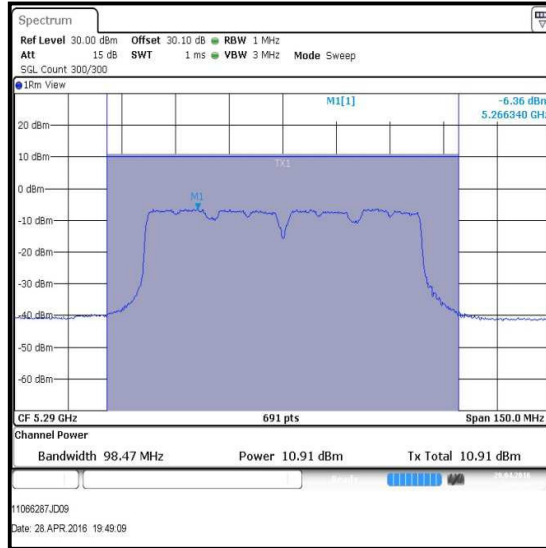

Single Channel

Results: 802.11ac / 80 MHz / 64QAM / MCS6x1 / 5.25-5.35 GHz band / Port 2

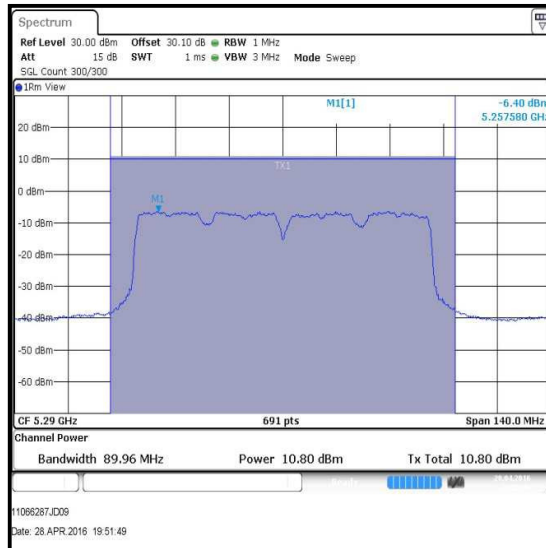

Single Channel

Transmitter Maximum Conducted Output Power (5.25-5.35 GHz & 5.47-5.725 GHz bands)
(continued)

Results: 802.11a / 20 MHz / 16QAM / 36 Mbps / 5.47-5.725 GHz band

Channel	Frequency (MHz)	Port 1			Port 2		
		Conducted Peak Power (dBm)	Duty Cycle Correction (dB)	Corrected Conducted Peak Power (dBm)	Conducted Peak Power (dBm)	Duty Cycle Correction (dB)	Corrected Conducted Peak Power (dBm)
Bottom	5500	14.9	0.6	15.5	14.6	0.6	15.2
Middle	5580	14.9	0.6	15.5	14.4	0.6	15.0
Top	5700	14.6	0.6	15.2	14.0	0.6	14.6

Channel	Frequency (MHz)	Corrected Conducted Peak Power Port 1 (dBm)	Corrected Conducted Peak Power Port 2 (dBm)	Combined Conducted Power (dBm)	Limit (dBm)	Margin (dB)	Result
Bottom	5500	15.5	15.2	18.4	24.0	5.6	Complied
Middle	5580	15.5	15.0	18.3	24.0	5.7	Complied
Top	5700	15.2	14.6	17.9	24.0	6.1	Complied

**Transmitter Maximum Conducted Output Power (5.25-5.35 GHz & 5.47-5.725 GHz bands)
(continued)**

Results: 802.11a / 20 MHz / 16QAM / 36 Mbps / 5.47-5.725 GHz band / Port 1

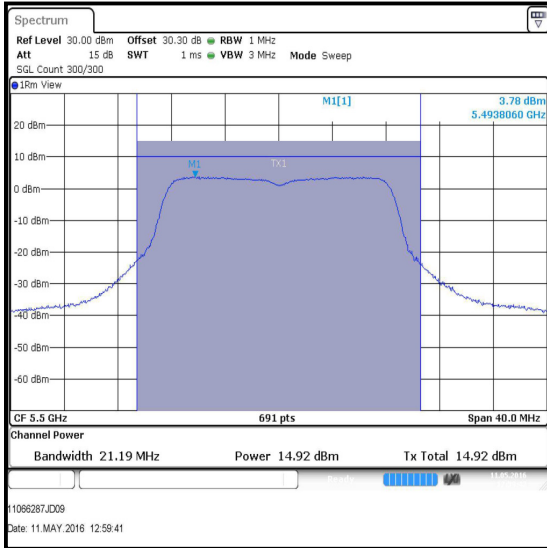

Bottom Channel

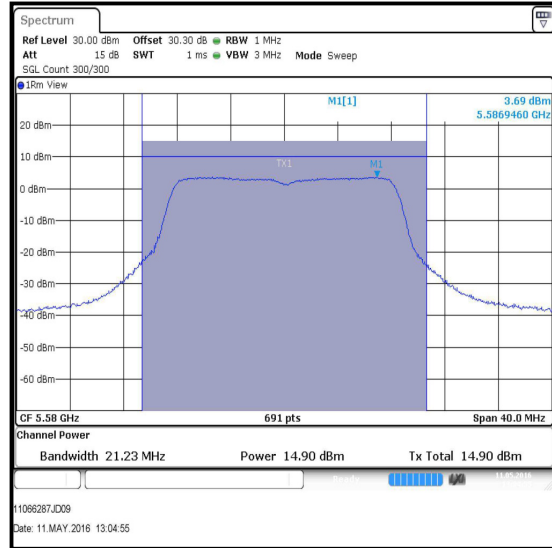

Middle Channel

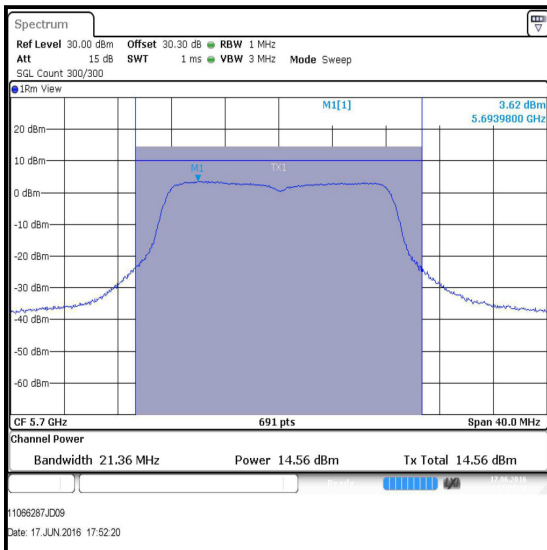

Top Channel

Transmitter Maximum Conducted Output Power (5.25-5.35 GHz & 5.47-5.725 GHz bands) (continued)

Results: 802.11a / 20 MHz / 16QAM / 36 Mbps / 5.47-5.725 GHz band / Port 2

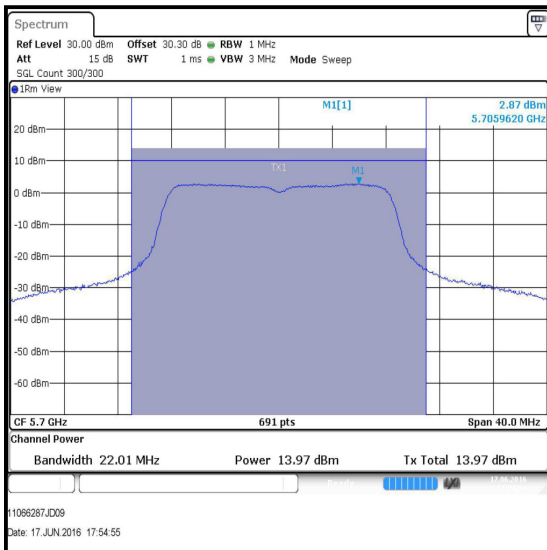
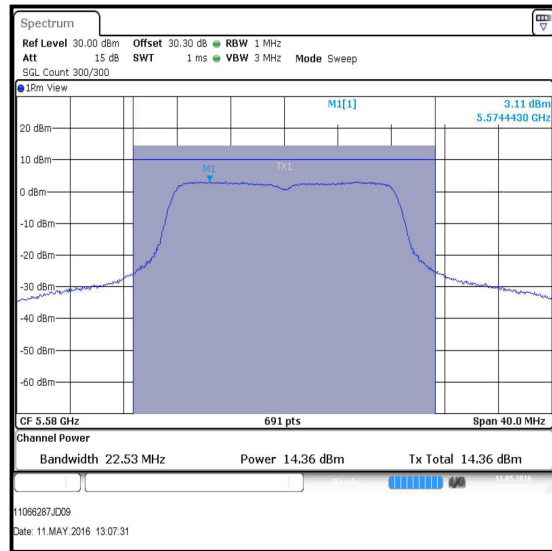
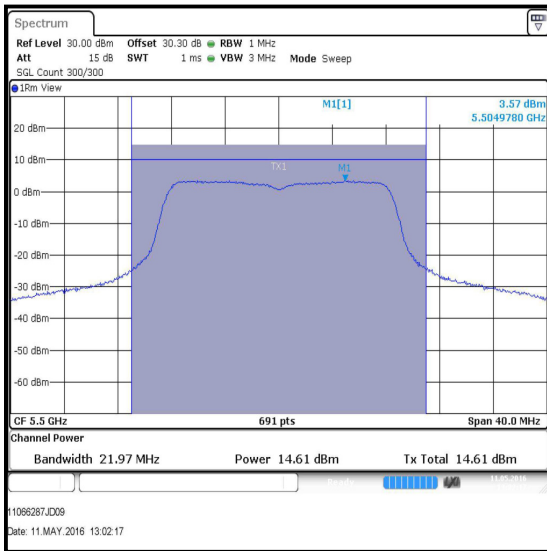

Transmitter Maximum Conducted Output Power (5.25-5.35 GHz & 5.47-5.725 GHz bands)
(continued)

Results: 802.11n / 20 MHz / 16QAM / MCS4 / 5.47-5.725 GHz band

Channel	Frequency (MHz)	Port 1			Port 2		
		Conducted Peak Power (dBm)	Duty Cycle Correction (dB)	Corrected Conducted Peak Power (dBm)	Conducted Peak Power (dBm)	Duty Cycle Correction (dB)	Corrected Conducted Peak Power (dBm)
Bottom	5500	13.4	0.6	14.0	13.0	0.6	13.6
Middle	5580	13.3	0.6	13.9	12.7	0.6	13.3
Top	5700	13.2	0.6	13.8	12.6	0.6	13.2

Channel	Frequency (MHz)	Corrected Conducted Peak Power Port 1 (dBm)	Corrected Conducted Peak Power Port 2 (dBm)	Combined Conducted Power (dBm)	Limit (dBm)	Margin (dB)	Result
Bottom	5500	14.0	13.6	16.8	24.0	7.2	Complied
Middle	5580	13.9	13.3	16.6	24.0	7.4	Complied
Top	5700	13.8	13.2	16.5	24.0	7.5	Complied