



FCC RADIO TEST REPORT

FCC ID : 2AIP8-SR00300W
Equipment : Smartphone
Brand Name : SIRIN LABS
Model Name : SR00300-W
Applicant : SIRIN LABS AG
Freier Platz 10, 8200 Schaffhausen, Switzerland
Manufacturer : SIRIN LABS AG
Freier Platz 10, 8200 Schaffhausen, Switzerland
Standard : 47 CFR Part 2, 27

The product was received on Oct. 18, 2018 and testing was started from Oct. 18, 2018 and completed on Nov. 21, 2018. We, SPORTON INTERNATIONAL INC., would like to declare that the tested sample has been evaluated in accordance with the test procedures given in ANSI / TIA-603-E and has been in compliance with the applicable technical standards.

The report must not be used by the client to claim product certification, approval, or endorsement by TAF or any agency of government.

The test results in this variant report apply exclusively to the tested model / sample. Without written approval of SPORTON INTERNATIONAL INC. EMC & Wireless Communications Laboratory, the test report shall not be reproduced except in full.

Approved by: Joseph Lin

SPORTON INTERNATIONAL INC. EMC & Wireless Communications Laboratory

No. 52, Huaya 1st Rd., Guishan Dist., Taoyuan City, Taiwan (R.O.C.)



Table of Contents

History of this test report.....	3
Summary of Test Result.....	4
1 General Description	5
1.1 Product Feature of Equipment Under Test.....	5
1.2 Modification of EUT	5
1.3 Testing Location	5
1.4 Applicable Standards.....	6
2 Test Configuration of Equipment Under Test	7
2.1 Test Mode.....	7
2.2 Connection Diagram of Test System.....	8
2.3 Support Unit used in test configuration and system	8
2.4 Measurement Results Explanation Example.....	8
2.5 Frequency List of Low/Middle/High Channels	9
3 Conducted Test Items.....	12
3.1 Measuring Instruments	12
3.2 Conducted Output Power and EIRP	13
3.3 Occupied Bandwidth.....	14
3.4 Conducted Band Edge	15
3.5 Conducted Spurious Emission	16
4 Radiated Test Items	17
4.1 Measuring Instruments	17
4.2 Radiated Spurious Emission	18
5 List of Measuring Equipment.....	19
6 Uncertainty of Evaluation.....	21
Appendix A. Test Results of Conducted Test	
Appendix B. Test Results of EIRP and Radiated Test	
Appendix C. Test Setup Photographs	



Summary of Test Result

Report Clause	Ref Std. Clause	Test Items	Result (PASS/FAIL)	Remark
3.2	§2.1046	Conducted Output Power	Reporting only	-
	§24.232 (c) §27.50 (h)(2)	Equivalent Isotropic Radiated Power (Band 7) (Band 41)	Pass	
-	-	Peak-to-Average Ratio	Not Required	-
3.3	§2.1049	Occupied Bandwidth	Reporting only	-
3.4	§2.1051 §27.53 (m)(4)	Conducted Band Edge Measurement (Band 7) (Band 41)	Pass	-
3.5	§2.1051 §27.53 (m)(4)	Conducted Spurious Emission (Band 7) (Band 41)	Pass	-
-	§2.1055 §27.54	Frequency Stability Temperature & Voltage	Not Required	-
4.2	§2.1053 §27.53 (g) §27.53 (h)	Radiated Spurious Emission (Band 4) (Band 12)	Pass	Under limit 17.22 dB at 10683.000 MHz
	§2.1053 §27.53 (m)(4)	Radiated Spurious Emission (Band 7) (Band 41)		

Remark:

- Not required means after assessing, test items are not necessary to carry out.
- This is a variant report by adding LTE CA Band 7 and 41 which are enabled by SW. All the test cases were performed on original report which can be referred to Sporton Report Number FG800518C. Based on the original report, the test cases were verified.

Declaration of Conformity:

The judgment of conformity in the report is based on the measurement results excluding the measurement uncertainty.

Comments and Explanations:

None

Reviewed by: Wii Chang

Report Producer: Polly Tsai



1 General Description

1.1 Product Feature of Equipment Under Test

GSM/CDMA/WCDMA/LTE, Bluetooth, Wi-Fi 2.4GHz 802.11b/g/n, Wi-Fi 5GHz 802.11a/n/ac, NFC, and GNSS

Product Specification subjective to this standard	
Antenna Type	WWAN: PIFA Antenna WLAN: <Ant. 1>: PIFA Antenna <Ant. 2>: PIFA Antenna Bluetooth: PIFA Antenna GPS / Glonass / BDS / Galileo: PIFA Antenna NFC: Loop Antenna

1.2 Modification of EUT

No modifications are made to the EUT during all test items.

1.3 Testing Location

Sporton Lab is accredited to ISO 17025 by Taiwan Accreditation Foundation (TAF code : 1190) and the FCC designation No. TW1190 and TW0007 under the FCC 2.948(e) by Mutual Recognition Agreement (MRA) in FCC Test.

Test Site	SPORTON INTERNATIONAL INC.
Test Site Location	No.52, Huaya 1st Rd., Guishan Dist., Taoyuan City, Taiwan (R.O.C.) TEL: +886-3-327-3456 FAX: +886-3-328-4978
Test Site No.	Sporton Site No. TH05-HY

Note: The test site complies with ANSI C63.4 2014 requirement.

Test Site	SPORTON INTERNATIONAL INC.
Test Site Location	No.58, Aly. 75, Ln. 564, Wenhua 3rd, Rd., Guishan Dist., Taoyuan City, Taiwan (R.O.C.) TEL: +886-3-327-0868 FAX: +886-3-327-0855
Test Site No.	Sporton Site No. 03CH12-HY

Note: The test site complies with ANSI C63.4 2014 requirement.



1.4 Applicable Standards

According to the specifications of the manufacturer, the EUT must comply with the requirements of the following standards:

- ♦ ANSI C63.26-2015
- ♦ ANSI / TIA-603-E
- ♦ 47 CFR Part 2, 27
- ♦ FCC KDB 971168 D01 Power Meas. License Digital Systems v03r01
- ♦ FCC KDB 412172 D01 Determining ERP and EIRP v01r01

Remark: All test items were verified and recorded according to the standards and without any deviation during the test.



2 Test Configuration of Equipment Under Test

2.1 Test Mode

Antenna port conducted and radiated test items listed below are performed according to KDB 971168 D01 Power Meas. License Digital Systems v03r01 with maximum output power.

For radiated measurement, pre-scanned in three orthogonal panels, X, Y, Z. The worst cases (Y plane for LTE Band 7_CA and Z plane for LTE Band 41_CA and LTE Band 4+12_CA) were recorded in this report.

Test Items	Band	Bandwidth (MHz)										Modulation			RB #			Test Channel		
		20+20	20+15	15+20	20+10	10+20	20+5	5+20	15+15	15+10	10+15	QPSK	16QAM	64QAM	1	Half	Full	L	M	H
Max. Output Power	7_CA	v	v	v	v	v	-	-	v	v	-	v	v	v	v	v	v	v	v	v
	41_CA	v	v	v	v	v	v	v	v	v	v	v	v	v	v	v	v	v	v	v
26dB and 99% Bandwidth	7_CA	v	v	v	v	v	-	-	v	v	-	v	v	v			v	v	v	v
	41_CA	v	v	v	v	v	v	v	v	v	v	v	v	v			v	v	v	v
Conducted Band Edge	7_CA	v	v	v	v	v	-	-	v	v	-	v	v	v	v		v	v		v
	41_CA	v	v	v	v	v	v	v	v	v	v	v	v	v	v		v	v		v
Conducted Spurious Emission	7_CA	v	v	v	v	v	-	-	v	v	-	v	v	v	v			v	v	v
	41_CA	v	v	v	v	v	v	v	v	v	v	v	v	v	v			v	v	v
E.I.R.P.	7_CA	v	v	v	v	v	-	-	v	v	-	v	v	v	v			v	v	v
	41_CA	v	v	v	v	v	v	v	v	v	v	v	v	v	v		v	v	v	v
Radiated Spurious Emission	7_CA	Worst Case																v	v	v
	41_CA	Worst Case																v	v	v
Remark	<ol style="list-style-type: none"> The mark "v" means that this configuration is chosen for testing The mark "-" means that this bandwidth is not supported. The device is investigated from 30MHz to 10 times of fundamental signal for radiated spurious emission test under different RB size/offset and modulations in exploratory test. Subsequently, only the worst case emissions are reported. 																			

Test Items	Band	Bandwidth (MHz)									Modulation			RB #			Test Channel			
		20+10									QPSK	16QAM	64QAM	1	Half	Full	L	M	H	
Radiated Spurious Emission	4+12_CA	Worst Case															v	v	v	
Remark	<ol style="list-style-type: none"> The mark "v" means that this configuration is chosen for testing The mark "-" means that this bandwidth is not supported. The device is investigated from 30MHz to 10 times of fundamental signal for radiated spurious emission test under different RB size/offset and modulations in exploratory test. Subsequently, only the worst case emissions are reported. 																			

2.2 Connection Diagram of Test System

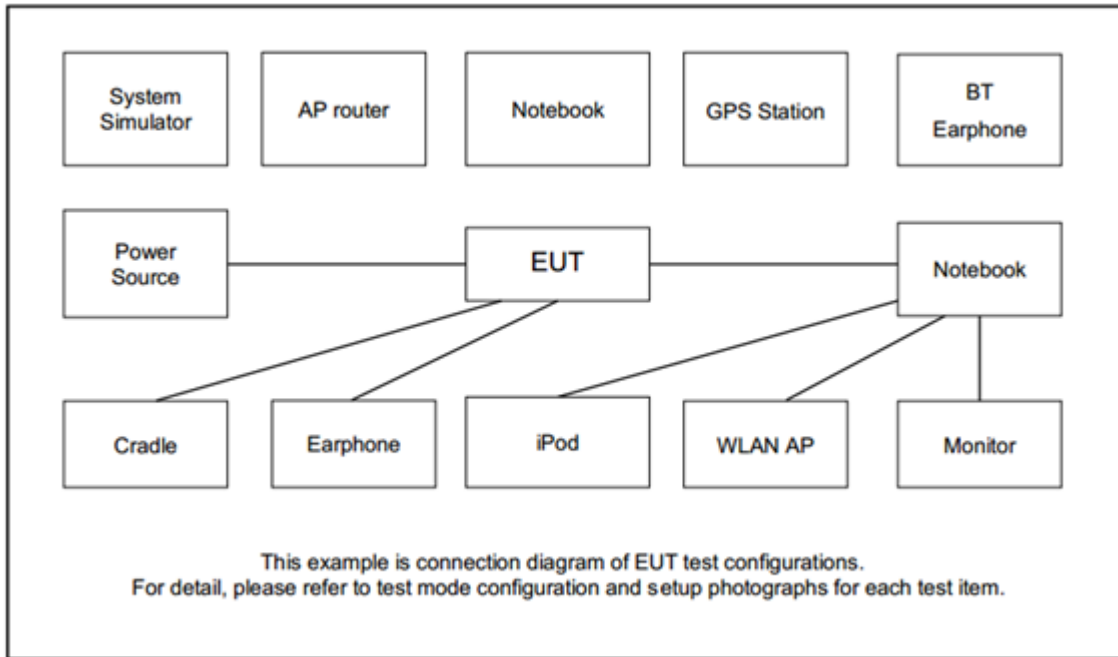

2.3 Support Unit used in test configuration and system

Item	Equipment	Trade Name	Model No.	FCC ID	Data Cable	Power Cord
1.	System Simulator	Anritsu	MT8821C	N/A	N/A	Unshielded, 1.8 m

2.4 Measurement Results Explanation Example

For all conducted test items:

The offset level is set in the spectrum analyzer to compensate the RF cable loss and attenuator factor between EUT conducted output port and spectrum analyzer. With the offset compensation, the spectrum analyzer reading level is exactly the EUT RF output level.

The spectrum analyzer offset is derived from RF cable loss and attenuator factor.

Offset = RF cable loss + attenuator factor.

Following shows an offset computation example with cable loss 4.2 dB and 10dB attenuator.

Example :

Offset(dB) = RF cable loss(dB) + attenuator factor(dB).

$$= 4.2 + 10 = 14.2 \text{ (dB)}$$



2.5 Frequency List of Low/Middle/High Channels

LTE Band 7 Channel and Frequency List_CA					
BW [MHz]	Channel/Frequency(MHz)		Lowest	Middle	Highest
20 + 20	PCC	Channel	20850	21001	21152
		Frequency	2510.0	2525.1	2540.2
	SCC	Channel	21048	21199	21350
		Frequency	2529.8	2544.9	2560.0
20 + 15	PCC	Channel	20850	21026	21201
		Frequency	2510.0	2527.6	2545.1
	SCC	Channel	21021	21197	21372
		Frequency	2527.1	2544.7	2562.2
15 + 20	PCC	Channel	20828	21003	21179
		Frequency	2507.8	2525.3	2542.9
	SCC	Channel	20999	21174	21350
		Frequency	2524.9	2542.4	2560.0
20 + 10	PCC	Channel	20850	21051	21251
		Frequency	2510.0	2530.1	2550.1
	SCC	Channel	20994	21195	21395
		Frequency	2524.4	2544.5	2564.5
10 + 20	PCC	Channel	20805	21006	21206
		Frequency	2505.5	2525.6	2545.6
	SCC	Channel	20949	21150	21350
		Frequency	2519.9	2540.0	2560.0
15 + 15	PCC	Channel	20825	21025	21225
		Frequency	2507.5	2527.5	2547.5
	SCC	Channel	20975	21175	21375
		Frequency	2522.5	2542.5	2562.5
15 + 10	PCC	Channel	20825	21051	21277
		Frequency	2507.5	2530.1	2552.7
	SCC	Channel	20945	21171	21397
		Frequency	2519.5	2542.1	2564.7



LTE Band 41 Channel and Frequency List					
BW [MHz]	Channel/Frequency(MHz)		Lowest	Middle	Highest
20 + 20	PCC	Channel	39750	40521	41292
		Frequency	2506.0	2583.1	2660.2
	SCC	Channel	39948	40719	41490
		Frequency	2525.8	2602.9	2680.0
20 + 15	PCC	Channel	39750	40546	41341
		Frequency	2506.0	2585.6	2665.1
	SCC	Channel	39921	40717	41512
		Frequency	2523.1	2602.7	2682.2
15 + 20	PCC	Channel	39728	40523	41319
		Frequency	2503.8	2593.3	2662.9
	SCC	Channel	39899	40694	41490
		Frequency	2520.9	2600.4	2680.0
20 + 10	PCC	Channel	39750	40571	41391
		Frequency	2506.0	2588.1	2670.1
	SCC	Channel	39894	40715	41535
		Frequency	2520.4	2602.5	2684.5
10 + 20	PCC	Channel	39705	40526	41346
		Frequency	2501.5	2583.6	2665.6
	SCC	Channel	39849	40670	41490
		Frequency	2515.9	2598.0	2680.0



LTE Band 41 Channel and Frequency List					
20 + 5	PCC	Channel	39750	40595	41440
		Frequency	2506.0	2590.5	2675.0
	SCC	Channel	39867	40712	41557
		Frequency	2517.7	2602.2	2686.7
5 + 20	PCC	Channel	39683	40528	41373
		Frequency	2499.3	2583.8	2668.3
	SCC	Channel	39800	40645	41490
		Frequency	2511.0	2595.5	2680.0
15 + 15	PCC	Channel	39725	40545	41365
		Frequency	2503.5	2585.5	2667.5
	SCC	Channel	39875	40695	41515
		Frequency	2518.5	2600.5	2682.5
10 + 15	PCC	Channel	39703	40549	41395
		Frequency	2501.3	2585.9	2670.5
	SCC	Channel	39823	40669	41515
		Frequency	2513.3	2597.9	2682.5
15 + 10	PCC	Channel	39725	40571	41417
		Frequency	2503.5	2588.1	2672.7
	SCC	Channel	39845	40691	41537
		Frequency	2515.5	2600.1	2684.7

3 Conducted Test Items

3.1 Measuring Instruments

See list of measuring instruments of this test report.

3.1.1 Test Setup

3.1.2 Conducted Output Power

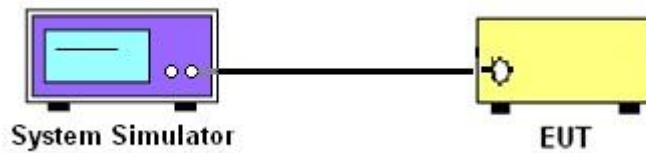

3.1.3 Peak-to-Average Ratio, Occupied Bandwidth ,Conducted Band-Edge and Conducted Spurious Emission

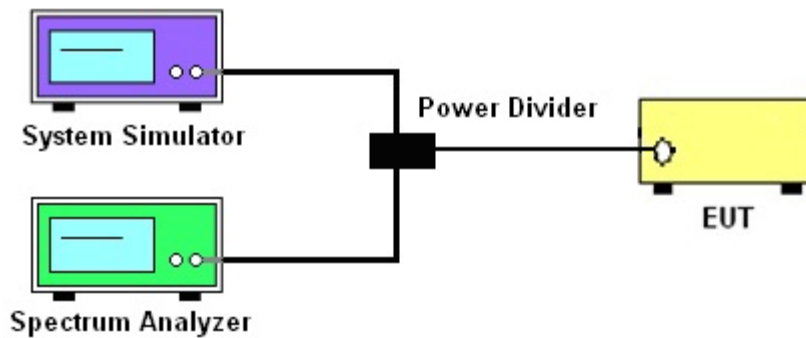

3.1.4 Test Result of Conducted Test

Please refer to Appendix A.



3.2 Conducted Output Power and EIRP

3.2.1 Description of the Conducted Output Power Measurement and EIRP Measurement

A system simulator was used to establish communication with the EUT. Its parameters were set to force the EUT transmitting at maximum output power. The measured power in the radio frequency on the transmitter output terminals shall be reported.

The EIRP of mobile transmitters must not exceed 2 Watts for LTE Band 7 and Band 41.

According to KDB 412172 D01 Power Approach,

$EIRP = P_T + G_T - L_C$, $ERP = EIRP - 2.15$, where

P_T = transmitter output power in dBm

G_T = gain of the transmitting antenna in dBi

L_C = signal attenuation in the connecting cable between the transmitter and antenna in dB

3.2.2 Test Procedures

1. The transmitter output port was connected to the system simulator.
2. Set EUT at maximum power through the system simulator.
3. Select lowest, middle, and highest channels for each band and different modulation.
4. Measure and record the power level from the system simulator.



3.3 Occupied Bandwidth

3.3.1 Description of Occupied Bandwidth Measurement

The occupied bandwidth is the width of a frequency band such that, below the lower and above the upper frequency limits, the mean powers emitted are each equal to a specified percentage 0.5% of the total mean transmitted power.

The 26 dB emission bandwidth is defined as the frequency range between two points, one above and one below the carrier frequency, at which the spectral density of the emission is attenuated 26 dB below the maximum in-band spectral density of the modulated signal. Spectral density (power per unit bandwidth) is to be measured with a detector of resolution bandwidth equal to approximately 1.0% of the emission bandwidth.

3.3.2 Test Procedures

The testing follows FCC KDB 971168 D01 v03r01 Section 4.2

1. The EUT was connected to spectrum analyzer and system simulator via a power divider.
2. The spectrum analyzer center frequency is set to the nominal EUT channel center frequency. The span range for the spectrum analyzer shall be between two and five times the anticipated OBW.
3. The nominal resolution bandwidth (RBW) shall be in the range of 1 to 5 % of the anticipated OBW, and the VBW shall be at least 3 times the RBW.
4. Set the detection mode to peak, and the trace mode to max hold.
5. Determine the reference value: Set the EUT to transmit a modulated signal. Allow the trace to stabilize. Set the spectrum analyzer marker to the highest level of the displayed trace.
(this is the reference value)
6. Determine the “-26 dB down amplitude” as equal to (Reference Value – X).
7. Place two markers, one at the lowest and the other at the highest frequency of the envelope of the spectral display such that each marker is at or slightly below the “-X dB down amplitude” determined in step 6. If a marker is below this “-X dB down amplitude” value it shall be placed as close as possible to this value. The OBW is the positive frequency difference between the two markers.
8. Use the 99 % power bandwidth function of the spectrum analyzer and report the measured bandwidth.



3.4 Conducted Band Edge

3.4.1 Description of Conducted Band Edge Measurement

27.53(m)(4)

For mobile digital stations, the attenuation factor shall be not less than $40 + 10 \log (P)$ dB on all frequencies between the channel edge and 5 megahertz from the channel edge, $43 + 10 \log (P)$ dB on all frequencies between 5 megahertz and X megahertz from the channel edge, and $55 + 10 \log (P)$ dB on all frequencies more than X megahertz from the channel edge, where X is the greater of 6 megahertz or the actual emission bandwidth as defined in paragraph (m)(6) of this section. In addition, the attenuation factor shall not be less than $43 + 10 \log (P)$ dB on all frequencies between 2490.5 MHz and 2496 MHz and $55 + 10 \log (P)$ dB at or below 2490.5 MHz. Mobile Satellite Service licensees operating on frequencies below 2495 MHz may also submit a documented interference complaint against BRS licensees operating on channel BRS Channel 1 on the same terms and conditions as adjacent channel BRS or EBS licensees.

3.4.2 Test Procedures

The testing follows FCC KDB 971168 D01 v03r01 Section 6.0.

1. The EUT was connected to spectrum analyzer and system simulator via a power divider.
2. The band edges of low and high channels for the highest RF powers were measured.
3. Set RBW \geq 1% EBW in the 1MHz band immediately outside and adjacent to the band edge.
4. Beyond the 1 MHz band from the band edge, RBW=1MHz was used.
5. Set spectrum analyzer with RMS detector.
6. The RF fundamental frequency should be excluded against the limit line in the operating frequency band.
7. Checked that all the results comply with the emission limit line.
The limit line is derived from $43 + 10\log(P)$ dB below the transmitter power P(Watts)
8. For LTE Band 7, 41, the other 40 dB, and 55 dB have additionally applied same calculation above.



3.5 Conducted Spurious Emission

3.5.1 Description of Conducted Spurious Emission Measurement

The power of any emission outside of the authorized operating frequency ranges must be lower than the transmitter power (P) by a factor of at least $43 + 10 \log (P)$ dB.

For Band 7,38,41:

The power of any emission outside of the authorized operating frequency ranges must be lower than the transmitter power (P) by a factor of at least $55 + 10 \log (P)$ dB.

It is measured by means of a calibrated spectrum analyzer and scanned from 30 MHz up to a frequency including its 10th harmonic.

3.5.2 Test Procedures

The testing follows FCC KDB 971168 D01 v03r01 Section 6.0.

1. The EUT was connected to spectrum analyzer and system simulator via a power divider.
2. The RF output of EUT was connected to the spectrum analyzer by RF cable and attenuator.
The path loss was compensated to the results for each measurement.
3. The middle channel for the highest RF power within the transmitting frequency was measured.
4. The conducted spurious emission for the whole frequency range was taken.
5. Make the measurement with the spectrum analyzer's RBW = 1MHz, VBW = 3MHz.
6. Set spectrum analyzer with RMS detector.
7. Taking the record of maximum spurious emission.
8. The RF fundamental frequency should be excluded against the limit line in the operating frequency band.
9. The limit line is derived from $43 + 10\log(P)$ dB below the transmitter power P(Watts)
10. For Band 7, 38, 41
The limit line is derived from $55 + 10\log(P)$ dB below the transmitter power P(Watts)

4 Radiated Test Items

4.1 Measuring Instruments

See list of measuring instruments of this test report.

4.1.1 Test Setup

For radiated test from 30MHz to 1GHz

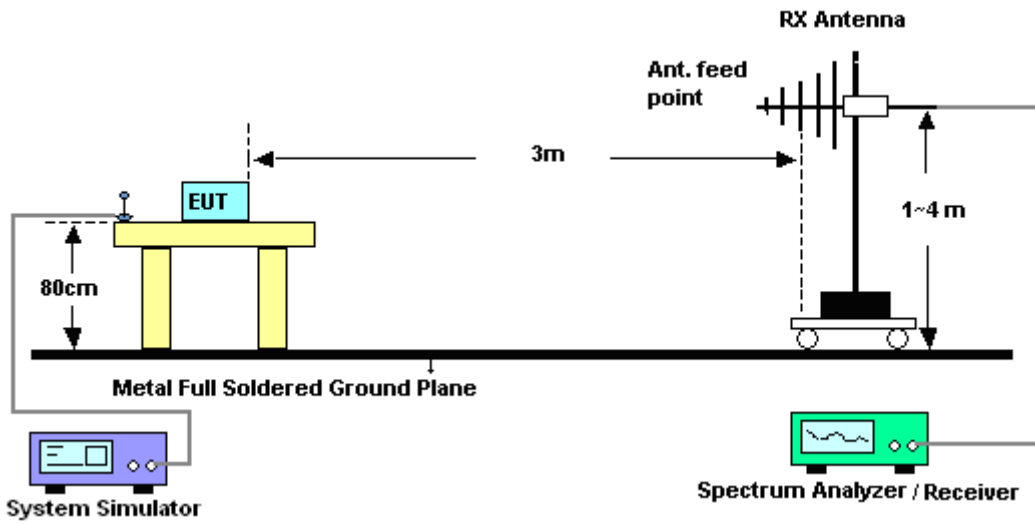

For radiated test above 1GHz

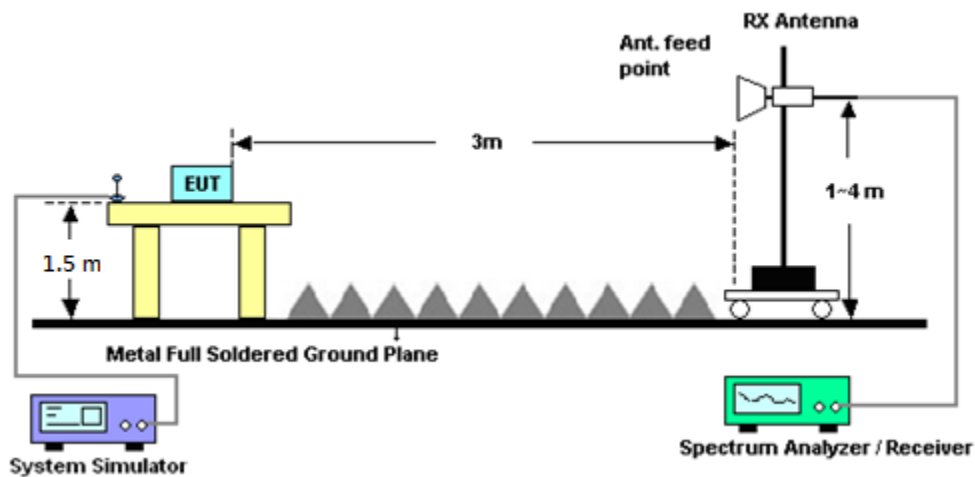

4.1.2 Test Result of Radiated Test

Please refer to Appendix B.



4.2 Radiated Spurious Emission

4.2.1 Description of Radiated Spurious Emission

The radiated spurious emission was measured by substitution method according to ANSI / TIA-603-E. The power of any emission outside of the authorized operating frequency ranges must be attenuated below the transmitter power (P) by a factor of at least $43 + 10 \log (P)$ dB.

For Band 7, 41

The power of any emission outside of the authorized operating frequency ranges must be attenuated below the transmitter power (P) by a factor of at least $55 + 10 \log (P)$ dB.

The spectrum is scanned from 30 MHz up to a frequency including its 10th harmonic.

4.2.2 Test Procedures

The testing follows FCC KDB 971168 D01 v03r01 Section 5.8 and ANSI / TIA-603-E Section 2.2.12.

1. The EUT was placed on a turntable with 0.8 meter for frequency below 1GHz and 1.5 meter for frequency above 1GHz respectively above ground.
2. The EUT was set 3 meters from the receiving antenna, which was mounted on the antenna tower.
3. The table was rotated 360 degrees to determine the position of the highest spurious emission.
4. The height of the receiving antenna is varied between one meter and four meters to search the maximum spurious emission for both horizontal and vertical polarizations.
5. Make the measurement with the spectrum analyzer's RBW = 1MHz, VBW = 3MHz, taking the record of maximum spurious emission.
6. A horn antenna was substituted in place of the EUT and was driven by a signal generator.
7. Tune the output power of signal generator to the same emission level with EUT maximum spurious emission.
8. Taking the record of output power at antenna port.
9. Repeat step 7 to step 8 for another polarization.
10. The RF fundamental frequency should be excluded against the limit line in the operating frequency band.

The limit line is derived from $43 + 10\log(P)$ dB below the transmitter power P(Watts)

11. For Band 7, 41:

The limit line is derived from $55 + 10\log(P)$ dB below the transmitter power P(Watts)

$EIRP \text{ (dBm)} = S.G. \text{ Power} - Tx \text{ Cable Loss} + Tx \text{ Antenna Gain}$

$ERP \text{ (dBm)} = EIRP - 2.15$



5 List of Measuring Equipment

Instrument	Manufacturer	Model No.	Serial No.	Characteristics	Calibration Date	Test Date	Due Date	Remark
LTE Base Station	Anritsu	MT8820C	620143282 1	GSM/GPRS /WCDMA/LTE	Oct. 14, 2018	Oct. 20, 2018~ Nov. 21, 2018	Oct. 13, 2019	Conducted (TH05-HY)
Base Station (Measure)	Anritsu	MT8821C	620166475 5	GSM / GPRS /WCDMA / LTE FDD/TDD with 44) /LTE-3CC DLCA,2CC ULCA	Mar. 26, 2018	Oct. 20, 2018~ Nov. 21, 2018	Mar. 25, 2019	Conducted (TH05-HY)
Spectrum Analyzer	Rohde & Schwarz	FSV40	101408	10Hz~40GHz	Jul. 30, 2018	Oct. 20, 2018~ Nov. 21, 2018	Jul. 29, 2019	Conducted (TH05-HY)
Temperature Chamber	ESPEC	SH-641	92013720	-40℃~90℃	Aug. 29, 2018	Oct. 20, 2018~ Nov. 21, 2018	Aug. 28, 2019	Conducted (TH05-HY)
Programmable Power Supply	GW Instek	PSS-2005	EL890094	1V~20V 0.5A~5A	Oct. 02, 2018	Oct. 20, 2018~ Nov. 21, 2018	Oct. 01, 2019	Conducted (TH05-HY)
Coupler	Warison	1-18GHz 20dB 25WSMA Directional Coupler	#B	1G~18GHz	Dec. 04, 2017	Oct. 20, 2018~ Nov. 21, 2018	Dec. 03, 2018	Conducted (TH04-HY)
Coupler	Warison	0.5-18GHz 10dB 30W	DOM5CIW 3A1	0.5-18GHz	Feb. 21, 2018	Oct. 20, 2018~ Nov. 21, 2018	Feb. 20, 2019	Conducted (TH05-HY)
Loop Antenna	Rohde & Schwarz	HFH2-Z2	100488	9 kHz~30 MHz	Nov. 23, 2017	Oct. 18, 2018~ Nov. 12, 2018	Nov. 22, 2018	Radiation (03CH12-HY)
Bilog Antenna	TESEQ	CBL 6111D&00802 N1D01N-06	47020&06	30MHz to 1GHz	Nov. 20, 2017	Oct. 18, 2018~ Nov. 12, 2018	Nov. 19, 2018	Radiation (03CH12-HY)
Horn Antenna	SCHWARZBECK	BBHA 9120D	9120D-121 2	1GHz ~ 18GHz	May 10, 2018	Oct. 18, 2018~ Nov. 12, 2018	May 09, 2019	Radiation (03CH12-HY)
SHF-EHF Horn Antenna	SCHWARZBECK	BBHA 9170	BBHA9170 584	18GHz ~ 40GHz	Nov. 27, 2017	Oct. 18, 2018~ Nov. 12, 2018	Nov. 26, 2018	Radiation (03CH12-HY)
Preamplifier	COM-POWER	PA-103	161075	10MHz~1GHz	Mar. 26, 2018	Oct. 18, 2018~ Nov. 12, 2018	Mar. 25, 2019	Radiation (03CH12-HY)
Preamplifier	Keysight	83017A	MY532701 48	1GHz~26.5GHz	Jan. 15, 2018	Oct. 18, 2018~ Nov. 12, 2018	Jan. 14, 2019	Radiation (03CH12-HY)
Preamplifier	MITEQ	AMF-7D-0010 1800-30-10P	1590074	1GHz~18GHz	May 21, 2018	Oct. 18, 2018~ Nov. 12, 2018	May 20, 2019	Radiation (03CH12-HY)
Preamplifier	EMEC	EM18G40G	060715	18GHz ~ 40GHz	Dec. 05, 2017	Oct. 18, 2018~ Nov. 12, 2018	Dec. 04, 2018	Radiation (03CH12-HY)
EMI Test Receiver	Rohde & Schwarz	ESU26	100390	20Hz~26.5GHz	Dec. 25, 2017	Oct. 18, 2018~ Nov. 12, 2018	Dec. 24, 2018	Radiation (03CH12-HY)
Spectrum Analyzer	Keysight	N9010A	MY553705 26	10Hz~44GHz	Mar. 15, 2018	Oct. 18, 2018~ Nov. 12, 2018	Mar. 14, 2019	Radiation (03CH12-HY)
Horn Antenna	SCHWARZBECK	BBHA 9120D	9120D-152 2	1GHz ~ 18GHz	May 10, 2018	Oct. 18, 2018~ Nov. 12, 2018	May 09, 2019	Radiation (03CH12-HY)
Signal Generator	Rohde & Schwarz	SMF100A	101107	100kHz~40GHz	May 21, 2018	Oct. 18, 2018~ Nov. 12, 2018	May 20, 2019	Radiation (03CH12-HY)
Base Station	Rohde & Schwarz	CMU200	106656	GSM/GPRS/WC DMA/CDMA	Nov. 15, 2016	Oct. 18, 2018~ Nov. 12, 2018	Nov. 14, 2018	Radiation (03CH12-HY)



Instrument	Manufacturer	Model No.	Serial No.	Characteristics	Calibration Date	Test Date	Due Date	Remark
Base Station	Anritsu	MT8821C	620143281 6	GSM / GPRS /WCDMA / LTE FDD/TDD with 44) /LTE-3CC DLCA,2CC ULCA	May 02, 2017	Oct. 18, 2018~ Nov. 12, 2018	May 01, 2019	Radiation (03CH12-HY)
Filter	Wainwright	WLKS1200-1 2SS	SN2	1.2GHz Low Pass	Mar. 21, 2018	Oct. 18, 2018~ Nov. 12, 2018	Mar. 20, 2019	Radiation (03CH12-HY)
Notch Filter	Wainwright	WRCD1800/2 000-20/40-10 SSK	SN1	LTE Band 25	Aug. 23, 2018	Oct. 18, 2018~ Nov. 12, 2018	Aug. 22, 2019	Radiation (03CH12-HY)
Notch Filter	Wainwright	WTRCD10-17 10-1785-20-4 0-40SSK	SN1	1710-1785	May 22, 2018	Oct. 18, 2018~ Nov. 12, 2018	May 21, 2019	Radiation (03CH12-HY)
Notch Filter	Wainwright	WRCT/800/96 0-0.2/40-8SS K	SN11	GSM850	Aug. 23, 2018	Oct. 18, 2018~ Nov. 12, 2018	Aug. 22, 2019	Radiation (03CH12-HY)
Notch Filter	Wainwright	WRCT2300/2 500-20/40-10 SSK	SN1	2300/2500	May 23, 2018	Oct. 18, 2018~ Nov. 12, 2018	May 22, 2019	Radiation (03CH12-HY)
RF Cable	HUBER + SUHNER	SUCOFLEX 126E	0058/126E	30M-18G	Mar. 14, 2018	Oct. 18, 2018~ Nov. 12, 2018	Mar. 13, 2019	Radiation (03CH12-HY)
RF Cable	HUBER + SUHNER	SUCOFLEX 102	505134/2	30M~40GHz	Oct. 16, 2018	Oct. 18, 2018~ Nov. 12, 2018	Oct. 15, 2019	Radiation (03CH12-HY)
RF Cable	HUBER + SUHNER	SUCOFLEX 102	800740/2	30M~40GHz	Oct. 16, 2018	Oct. 18, 2018~ Nov. 12, 2018	Oct. 15, 2019	Radiation (03CH12-HY)
Antenna Mast	EMEC	AM-BS-4500- B	N/A	1m~4m	N/A	Oct. 18, 2018~ Nov. 12, 2018	N/A	Radiation (03CH12-HY)
Turn Table	EMEC	TT2000	N/A	0~360 Degree	N/A	Oct. 18, 2018~ Nov. 12, 2018	N/A	Radiation (03CH12-HY)
Software	Audix	E3 6.2009-8-24	RK-00098 9	N/A	N/A	Oct. 18, 2018~ Nov. 12, 2018	N/A	Radiation (03CH12-HY)



6 Uncertainty of Evaluation

Uncertainty of Radiated Emission Measurement (30 MHz ~ 1000 MHz)

Measuring Uncertainty for a Level of Confidence of 95% ($U = 2Uc(y)$)	3.36
---	------

Uncertainty of Radiated Emission Measurement (1 GHz ~ 18 GHz)

Measuring Uncertainty for a Level of Confidence of 95% ($U = 2Uc(y)$)	3.70
---	------

Uncertainty of Radiated Emission Measurement (18 GHz ~ 40 GHz)

Measuring Uncertainty for a Level of Confidence of 95% ($U = 2Uc(y)$)	3.98
---	------



Appendix A. Test Results of Conducted Test

Conducted Output Power(Average power)

LTE Band 7_CA Maximum Average Power [dBm]									
BW [MHz]	PCC		SCC		Mod	Lowest	Middle	Highest	
	RB Size	RB Offset	RB Size	RB Offset					
20+20	0	0	1	99	QPSK	22.45	21.95	22.07	
20+20	1	0	0	0		19.79	21.47	21.49	
20+20	100	0	0	0		19.31	19.99	20.01	
20+20	100	0	100	0		19.80	19.60	19.80	
20+20	1	0	1	99		12.10	12.10	12.80	
20+20	1	0	1	0		15.81	16.92	15.93	
20+20	1	99	1	0		22.00	21.40	22.81	
20+20	100	0	1	99		19.31	18.13	18.41	
20+20	0	0	1	99		21.35	20.92	20.98	
20+20	1	0	0	0	16-QAM	18.55	20.14	20.41	
20+20	100	0	0	0		19.08	19.09	19.90	
20+20	100	0	100	0		15.70	16.80	17.90	
20+20	1	0	1	99		12.80	13.10	13.20	
20+20	1	0	1	0		15.91	17.19	16.01	
20+20	1	99	1	0		21.90	21.40	22.40	
20+20	100	0	1	99		18.27	18.71	18.31	
20+20	0	0	1	99		20.55	20.80	20.07	
20+20	1	0	0	0		17.20	19.81	19.37	
20+20	100	0	0	0	64-QAM	17.69	19.00	19.97	
20+20	100	0	100	0		16.50	17.70	17.40	
20+20	1	0	1	99		13.00	13.20	12.60	
20+20	1	0	1	0		14.88	16.90	15.97	
20+20	1	99	1	0		19.90	19.68	21.70	
20+20	100	0	1	99		18.17	19.25	17.97	
20+15	100	0	75	0		QPSK	19.70	19.60	19.90
20+15	1	0	1	74			12.50	12.70	12.60
20+15	1	99	1	0			21.90	21.20	22.80
20+15	100	0	75	0	16-QAM	16.10	17.00	18.30	
20+15	1	0	1	74		12.80	13.20	13.30	
20+15	1	99	1	0		21.80	21.30	22.60	
20+15	100	0	75	0	64-QAM	20.20	19.97	19.21	
20+15	1	0	1	74		14.53	14.55	14.47	
20+15	1	99	1	0		20.30	20.57	20.21	
15+20	75	0	100	0	QPSK	19.40	19.50	19.80	
15+20	1	0	1	99		12.20	12.00	12.70	
15+20	1	74	1	0		21.70	20.90	22.20	
15+20	75	0	100	0	16-QAM	15.40	17.00	18.20	
15+20	1	0	1	99		12.50	13.30	13.50	
15+20	1	74	1	0		21.40	21.00	22.00	
15+20	75	0	100	0	64-QAM	14.30	16.10	15.98	
15+20	1	0	1	99		11.90	12.90	12.30	
15+20	1	74	1	0		20.90	19.90	19.00	



LTE Band 7_CA Maximum Average Power [dBm]								
BW [MHz]	PCC		SCC		Mod	Lowest	Middle	Highest
	RB Size	RB Offset	RB Size	RB Offset				
20+10	100	0	75	0	QPSK	19.70	19.60	19.40
20+10	1	0	1	74		12.10	12.40	12.60
20+10	1	99	1	0		22.00	21.40	22.60
20+10	100	0	75	0	16-QAM	18.80	18.70	18.90
20+10	1	0	1	74		13.10	13.20	13.80
20+10	1	99	1	0		21.80	21.40	22.40
20+10	100	0	75	0	64-QAM	17.90	17.30	18.20
20+10	1	0	1	74		12.90	12.10	13.10
20+10	1	99	1	0		21.40	21.20	22.21
10+20	75	0	100	0	QPSK	19.20	19.60	19.80
10+20	1	0	1	99		12.20	12.40	12.70
10+20	1	74	1	0		21.70	20.70	22.20
10+20	75	0	100	0	16-QAM	18.40	18.70	19.00
10+20	1	0	1	99		12.80	13.60	13.40
10+20	1	74	1	0		21.10	20.80	21.90
10+20	75	0	100	0	64-QAM	17.50	17.50	18.20
10+20	1	0	1	99		12.50	12.90	12.90
10+20	1	74	1	0		20.40	20.50	20.50
15+15	75	0	100	0	QPSK	14.60	15.70	17.30
15+15	1	0	1	99		12.30	12.60	12.90
15+15	1	74	1	0		21.80	20.90	22.50
15+15	75	0	100	0	16-QAM	14.00	15.20	16.70
15+15	1	0	1	99		12.50	12.90	13.20
15+15	1	74	1	0		21.40	21.00	22.20
15+15	75	0	100	0	64-QAM	12.90	14.80	15.90
15+15	1	0	1	99		12.20	12.50	12.80
15+15	1	74	1	0		20.90	20.50	21.90
15+10	75	0	100	0	QPSK	19.50	19.60	19.50
15+10	1	0	1	99		11.80	12.50	12.40
15+10	1	74	1	0		21.80	21.00	22.50
15+10	75	0	100	0	16-QAM	18.60	18.70	18.80
15+10	1	0	1	99		12.40	12.80	13.50
15+10	1	74	1	0		21.40	20.90	22.10
15+10	75	0	100	0	64-QAM	17.80	17.80	17.60
15+10	1	0	1	99		11.60	12.30	12.80
15+10	1	74	1	0		20.90	20.40	21.80



LTE Band 41_CA Maximum Average Power [dBm]								
BW [MHz]	PCC		SCC		Mod	Lowest	Middle	Highest
	RB Size	RB Offset	RB Size	RB Offset				
20+20	0	0	1	99	QPSK	21.40	22.52	21.56
20+20	1	0	0	0		20.20	22.31	22.52
20+20	100	0	0	0		20.15	21.48	21.18
20+20	100	0	100	0		15.23	16.49	16.14
20+20	1	0	1	99		12.28	13.84	13.68
20+20	1	0	1	0		16.29	17.83	17.79
20+20	1	99	1	0		21.37	22.51	22.44
20+20	100	0	1	99		17.65	18.94	18.55
20+20	0	0	1	99	16-QAM	21.38	22.57	21.53
20+20	1	0	0	0		19.61	21.94	21.81
20+20	100	0	0	0		19.23	20.59	20.31
20+20	100	0	100	0		15.28	16.57	16.24
20+20	1	0	1	99		12.71	14.31	14.17
20+20	1	0	1	0		16.61	18.28	18.23
20+20	1	99	1	0		20.47	21.78	21.31
20+20	100	0	1	99		17.83	18.93	18.61
20+20	0	0	1	99	64-QAM	21.37	22.53	21.55
20+20	1	0	0	0		18.47	20.66	20.68
20+20	100	0	0	0		18.29	19.59	19.28
20+20	100	0	100	0		15.26	16.59	16.18
20+20	1	0	1	99		12.51	14.09	13.95
20+20	1	0	1	0		16.31	18.07	17.79
20+20	1	99	1	0		18.18	19.62	19.17
20+20	100	0	1	99		17.74	19.02	18.64
20+15	100	0	75	0	QPSK	19.12	20.18	19.37
20+15	1	0	1	74		12.18	16.10	13.37
20+15	1	99	1	0		21.08	22.17	21.76
20+15	100	0	75	0	16-QAM	18.21	19.31	18.87
20+15	1	0	1	74		12.67	14.18	13.91
20+15	1	99	1	0		20.30	21.29	20.91
20+15	100	0	75	0	64-QAM	18.23	19.32	18.58
20+15	1	0	1	74		12.34	13.84	13.59
20+15	1	99	1	0		18.03	19.13	18.66
15+20	75	0	100	0	QPSK	19.81	18.08	17.60
15+20	1	0	1	99		11.63	11.61	11.13
15+20	1	74	1	0		20.31	19.98	19.75
15+20	75	0	100	0	16-QAM	17.97	17.20	16.75
15+20	1	0	1	99		12.12	12.08	11.65
15+20	1	74	1	0		19.63	19.25	18.95
15+20	75	0	100	0	64-QAM	17.98	17.21	16.43
15+20	1	0	1	99		11.78	11.83	11.29
15+20	1	74	1	0		17.40	17.02	16.70



LTE Band 41_CA Maximum Average Power [dBm]								
BW [MHz]	PCC		SCC		Mod	Lowest	Middle	Highest
	RB Size	RB Offset	RB Size	RB Offset				
20+10	100	0	50	0	QPSK	14.37	14.03	13.45
20+10	1	0	1	49		11.66	11.62	11.05
20+10	1	99	1	0		20.35	19.79	19.26
20+10	100	0	50	0	16-QAM	14.44	14.12	13.60
20+10	1	0	1	49		12.16	12.15	11.56
20+10	1	99	1	0		19.61	19.14	18.59
20+10	100	0	50	0	64-QAM	14.41	14.12	13.54
20+10	1	0	1	49		11.82	11.81	11.30
20+10	1	99	1	0		17.42	16.87	16.33
10+20	50	0	100	0	QPSK	14.21	14.15	13.62
10+20	1	0	1	99		11.62	11.60	11.07
10+20	1	49	1	0		20.23	20.03	19.69
10+20	50	0	100	0	16-QAM	14.35	14.26	13.71
10+20	1	0	1	99		12.17	12.10	11.58
10+20	1	49	1	0		19.56	19.31	19.00
10+20	50	0	100	0	64-QAM	14.38	14.24	13.69
10+20	1	0	1	99		11.82	11.79	11.25
10+20	1	49	1	0		17.17	17.07	16.72
20+5	100	0	25	0	QPSK	14.43	14.05	13.32
20+5	1	0	1	24		11.59	11.66	10.94
20+5	1	99	1	0		20.36	19.85	19.17
20+5	100	0	25	0	16-QAM	14.43	14.12	13.44
20+5	1	0	1	24		12.11	12.07	11.45
20+5	1	99	1	0		19.60	19.18	18.46
20+5	100	0	25	0	64-QAM	14.44	14.15	13.40
20+5	1	0	1	24		11.82	11.74	11.18
20+5	1	99	1	0		17.41	16.90	16.20
5+20	25	0	100	0	QPSK	14.19	14.09	13.52
5+20	1	0	1	99		11.63	11.58	10.92
5+20	1	24	1	0		20.30	20.32	19.84
5+20	25	0	100	0	16-QAM	14.29	14.20	13.63
5+20	1	0	1	99		12.11	12.04	11.42
5+20	1	24	1	0		19.55	19.52	19.05
5+20	25	0	100	0	64-QAM	14.30	14.25	13.58
5+20	1	0	1	99		11.84	11.76	11.17
5+20	1	24	1	0		17.30	17.16	16.78



LTE Band 41_CA Maximum Average Power [dBm]								
BW [MHz]	PCC		SCC		Mod	Lowest	Middle	Highest
	RB Size	RB Offset	RB Size	RB Offset				
15+10	75	0	50	0	QPSK	18.38	17.97	17.42
15+10	1	0	1	49		11.63	11.54	10.93
15+10	1	74	1	0		20.38	19.92	19.41
15+10	75	0	50	0	16-QAM	17.43	17.09	16.45
15+10	1	0	1	49		12.15	12.03	11.43
15+10	1	74	1	0		19.70	19.22	18.69
15+10	75	0	50	0	64-QAM	17.46	17.14	16.53
15+10	1	0	1	49		11.82	11.73	11.15
15+10	1	74	1	0		17.43	16.96	16.41
10+15	50	0	75	0	QPSK	18.29	18.08	17.48
10+15	1	49	1	0		20.24	20.01	19.54
10+15	1	0	1	74		11.66	11.58	10.94
10+15	50	0	75	0	16-QAM	17.40	17.23	16.61
10+15	1	49	1	0		19.56	19.33	18.81
10+15	1	0	1	74		12.15	12.08	11.47
10+15	50	0	75	0	64-QAM	17.40	17.22	16.24
10+15	1	49	1	0		17.37	17.02	16.55
10+15	1	0	1	74		11.86	11.76	11.15
15+15	75	0	75	0	QPSK	15.09	16.38	15.98
15+15	1	0	1	74		12.22	13.85	13.53
15+15	1	74	1	0		20.40	20.04	19.58
15+15	75	0	75	0	16-QAM	15.14	16.45	16.01
15+15	1	0	1	74		12.68	14.34	14.02
15+15	1	74	1	0		19.80	19.25	18.85
15+15	75	0	75	0	64-QAM	15.15	16.48	16.04
15+15	1	0	1	74		12.37	14.07	13.76
15+15	1	74	1	0		17.52	17.08	16.60



LTE Band 4+12_CA Maximum Average Power [dBm]								
BW [MHz]	PCC		SCC		Mod	Lowest	Middle	Highest
	RB Size	RB Offset	RB Size	RB Offset				
20+10	1	0	1	0	QPSK	22.75	22.94	22.77
20+10	1	49	1	25		22.61	22.68	22.52
20+10	1	99	1	49		22.62	22.59	22.46
20+10	50	0	25	0		22.74	22.78	22.69
20+10	50	24	25	12		22.81	22.73	22.61
20+10	50	50	25	25		22.72	22.66	22.50
20+10	100	0	50	0		22.80	22.71	22.60
20+10	1	0	1	0	16QAM	22.89	22.92	22.89
20+10	1	49	1	25		22.82	22.83	22.60
20+10	1	99	1	49		22.76	22.70	22.59
20+10	50	0	25	0		22.85	22.88	22.78
20+10	50	24	25	12		22.93	22.84	22.70
20+10	50	50	25	25		22.83	22.73	22.58
20+10	100	0	50	0		22.91	22.81	22.69
20+10	1	0	1	0	64QAM	22.85	22.86	22.84
20+10	1	49	1	25		22.80	22.78	22.57
20+10	1	99	1	49		22.81	22.64	22.52
20+10	50	0	25	0		22.69	22.79	22.69
20+10	50	24	25	12		22.85	22.73	22.61
20+10	50	50	25	25		22.75	22.67	22.49
20+10	100	0	50	0		22.82	22.73	22.61



LTE Band 7_CA

26dB Bandwidth

Mode	LTE Band 7 : 26dB BW(MHz)			
QPSK				
BW	10MHz+20MHz	15MHz+5MHz	15MHz+10MHz	15MHz+15MHz
Lowest CH	29.85	-	25.23	30.51
Middle CH	29.91	-	25.27	30.45
Highest CH	29.85	-	25.27	30.51
BW	15MHz+20MHz	20MHz+10MHz	20MHz+15MHz	20MHz+20MHz
Lowest CH	34.97	29.91	35.18	39.96
Middle CH	34.97	30.03	34.90	40.12
Highest CH	34.83	29.97	34.97	39.88

Mode	LTE Band 7 : 26dB BW(MHz)			
16QAM				
BW	10MHz+20MHz	15MHz+5MHz	15MHz+10MHz	15MHz+15MHz
Lowest CH	29.91	-	25.27	30.51
Middle CH	29.85	-	25.38	30.51
Highest CH	29.73	-	25.27	30.51
BW	15MHz+20MHz	20MHz+10MHz	20MHz+15MHz	20MHz+20MHz
Lowest CH	34.90	30.03	34.97	39.88
Middle CH	34.83	30.03	34.97	40.20
Highest CH	34.97	30.03	34.83	39.72

Mode	LTE Band 7 : 26dB BW(MHz)			
64QAM				
BW	10MHz+20MHz	15MHz+5MHz	15MHz+10MHz	15MHz+15MHz
Lowest CH	29.79	-	25.12	30.51
Middle CH	29.79	-	25.12	30.39
Highest CH	29.73	-	25.12	30.57
BW	15MHz+20MHz	20MHz+10MHz	20MHz+15MHz	20MHz+20MHz
Lowest CH	34.69	29.91	34.97	39.88
Middle CH	34.76	30.09	34.97	40.20
Highest CH	34.97	29.91	34.90	39.80



LTE Band 7

QPSK

Lowest Channel / 10MHz+20MHz

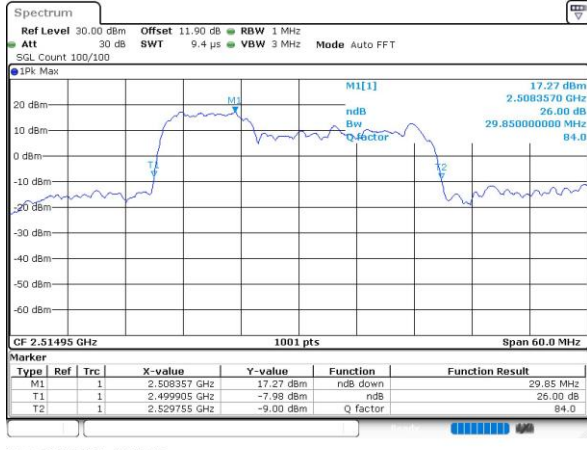

Middle Channel / 10MHz+20MHz

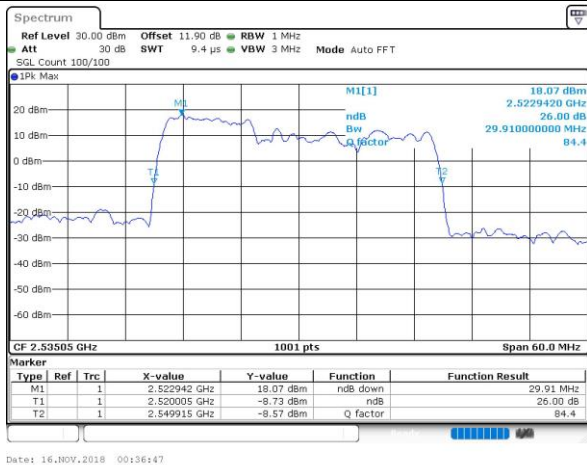

Highest Channel / 10MHz+20MHz

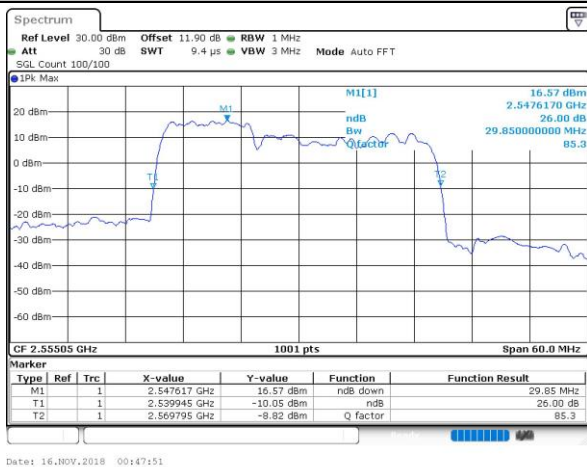



LTE Band 7

QPSK

Lowest Channel / 15MHz+10MHz

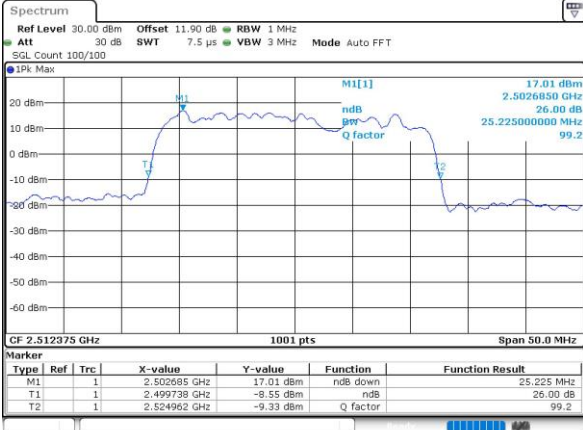

Date: 15.NOV.2018 23:24:01

Lowest Channel / 15MHz+15MHz

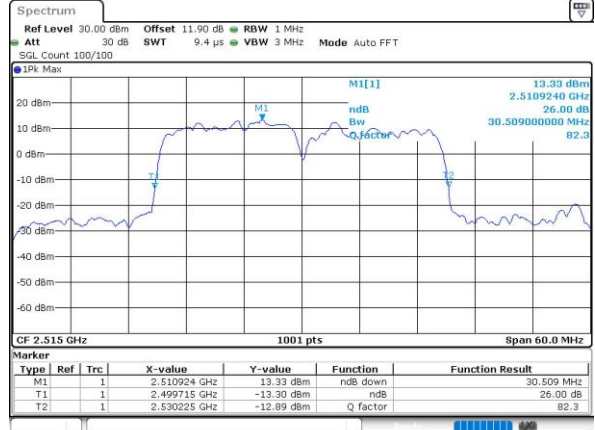

Date: 15.NOV.2018 17:16:20

Middle Channel / 15MHz+10MHz

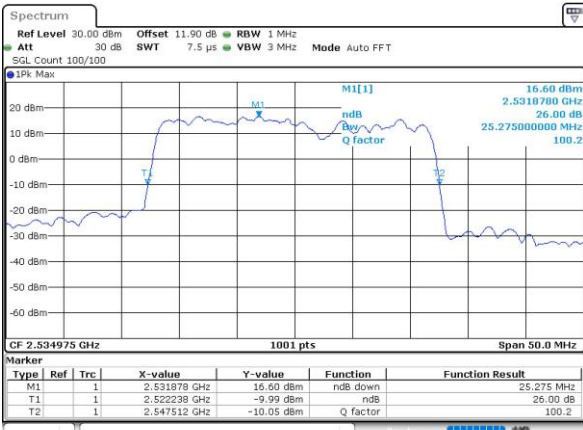

Date: 15.NOV.2018 23:40:20

Middle Channel / 15MHz+15MHz

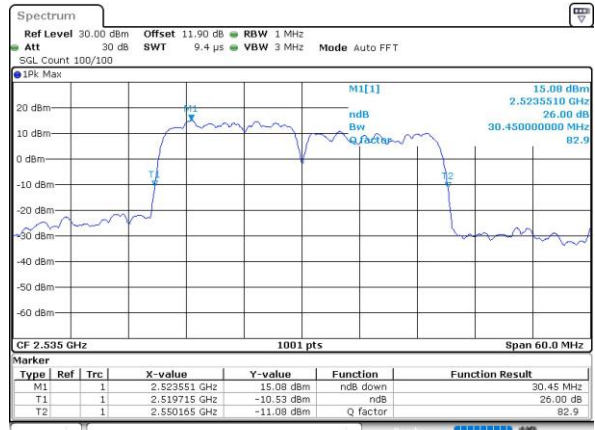

Date: 15.NOV.2018 22:24:03

Highest Channel / 15MHz+10MHz

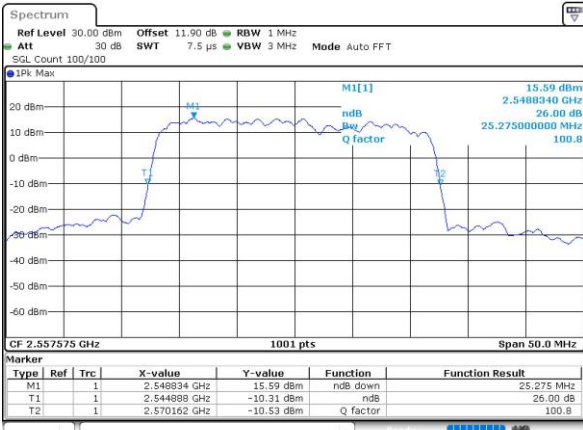

Date: 15.NOV.2018 23:51:24

Highest Channel / 15MHz+15MHz

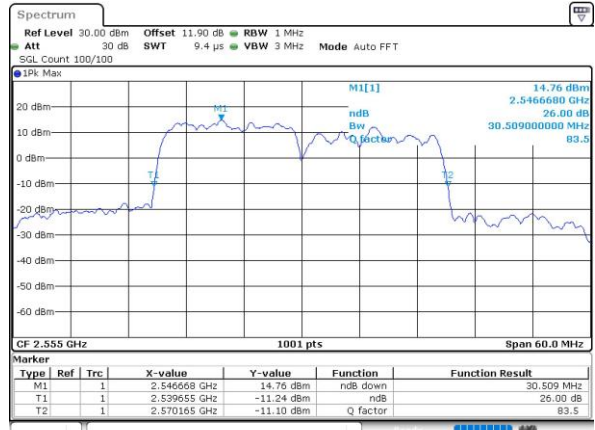

Date: 15.NOV.2018 22:35:06



LTE Band 7

QPSK

Lowest Channel / 15MHz+20MHz

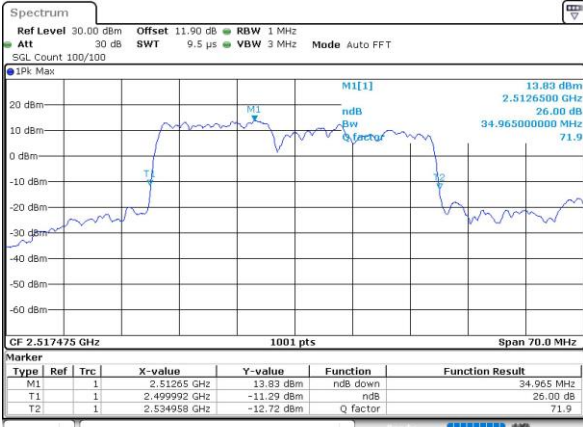

Date: 15.NOV.2018 15:40:46

Lowest Channel / 20MHz+10MHz

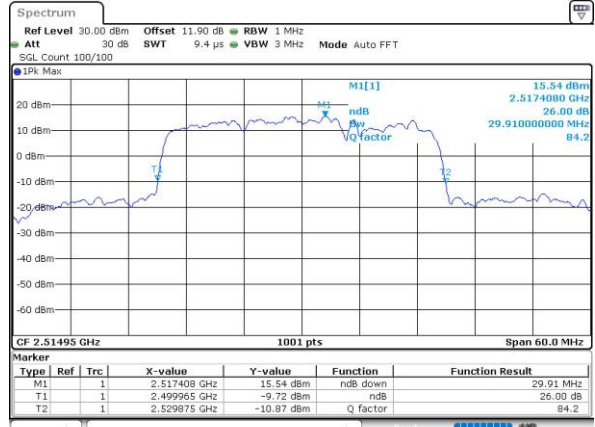

Date: 15.NOV.2018 14:37:21

Middle Channel / 15MHz+20MHz



Date: 15.NOV.2018 15:59:18

Middle Channel / 20MHz+10MHz

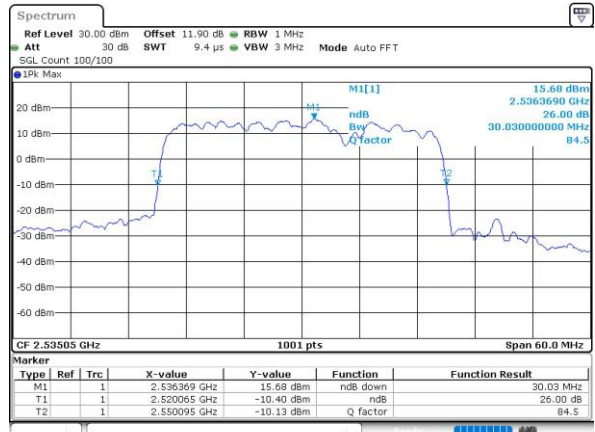

Date: 15.NOV.2018 14:55:53

Highest Channel / 15MHz+20MHz



Date: 15.NOV.2018 16:50:56

Highest Channel / 20MHz+10MHz

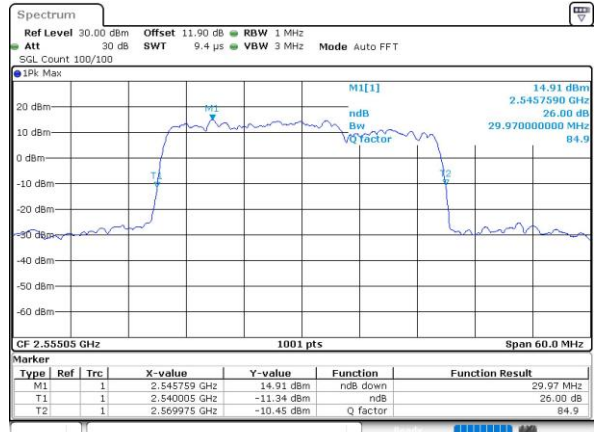

Date: 15.NOV.2018 15:06:41



LTE Band 7

QPSK

Lowest Channel / 20MHz+15MHz

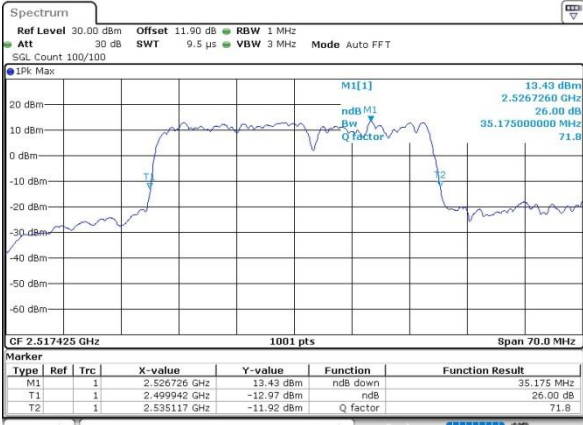

Date: 15.NOV.2018 13:09:28

Lowest Channel / 20MHz+20MHz

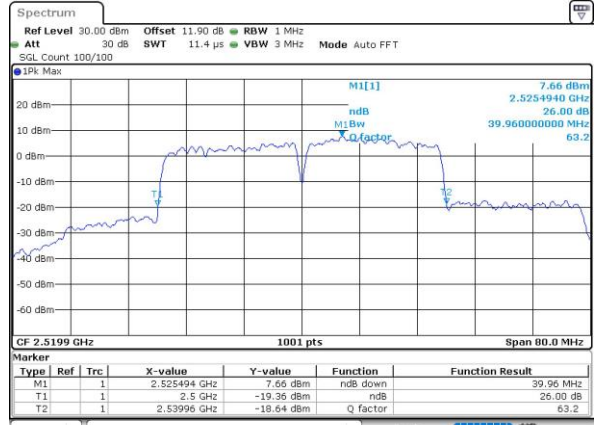

Date: 13.NOV.2018 14:20:46

Middle Channel / 20MHz+15MHz

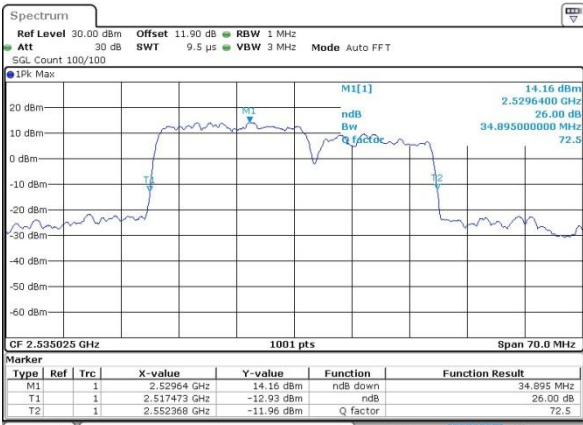

Date: 15.NOV.2018 13:21:50

Middle Channel / 20MHz+20MHz

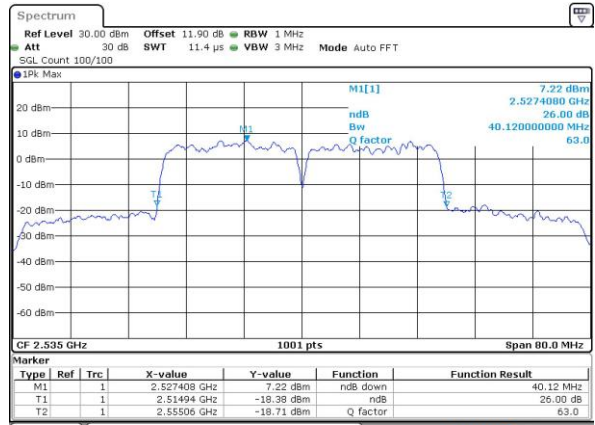

Date: 13.NOV.2018 14:37:14

Highest Channel / 20MHz+15MHz

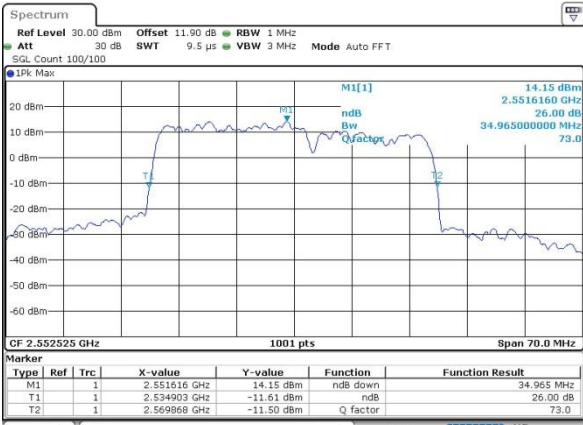

Date: 15.NOV.2018 13:33:18

Highest Channel / 20MHz+20MHz

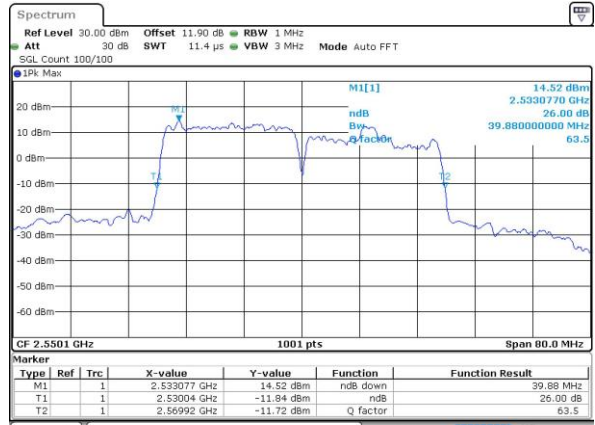

Date: 15.NOV.2018 14:00:04



LTE Band 7

16QAM

Lowest Channel / 10MHz+20MHz

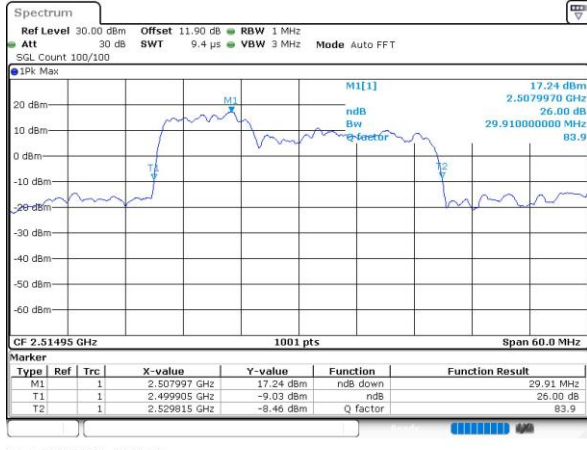

Date: 16.NOV.2018 00:19:18

Middle Channel / 10MHz+20MHz

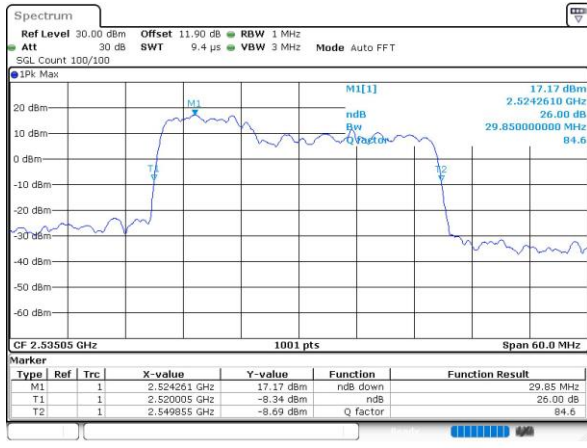

Date: 16.NOV.2018 00:36:21

Highest Channel / 10MHz+20MHz

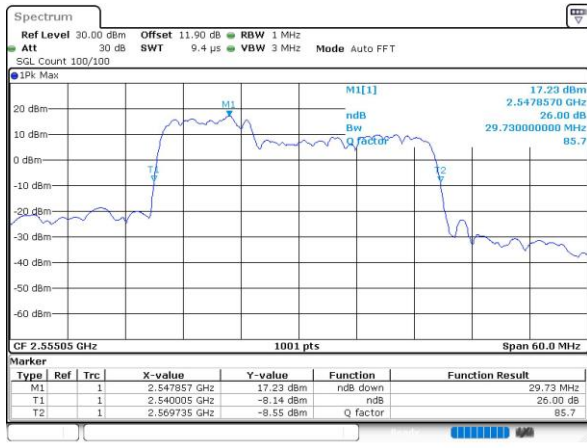

Date: 16.NOV.2018 00:48:17



LTE Band 7

16QAM

Lowest Channel / 15MHz+10MHz

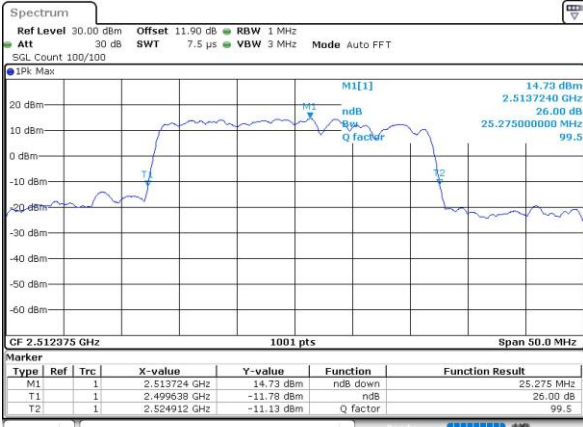

Date: 15.NOV.2018 23:23:35

Lowest Channel / 15MHz+15MHz

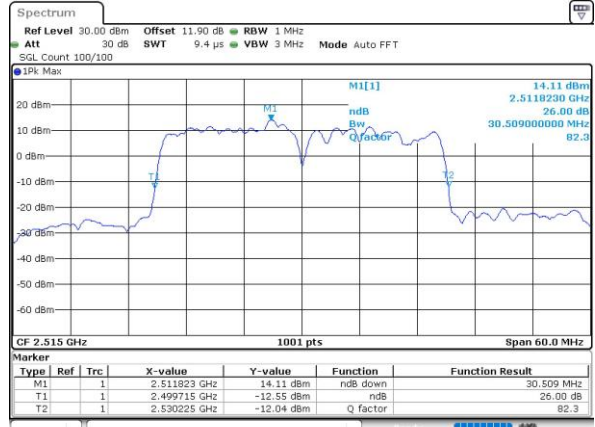

Date: 15.NOV.2018 17:15:54

Middle Channel / 15MHz+10MHz

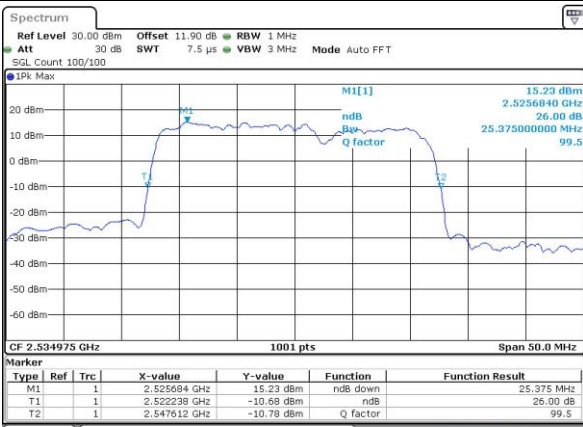

Date: 15.NOV.2018 23:39:54

Middle Channel / 15MHz+15MHz

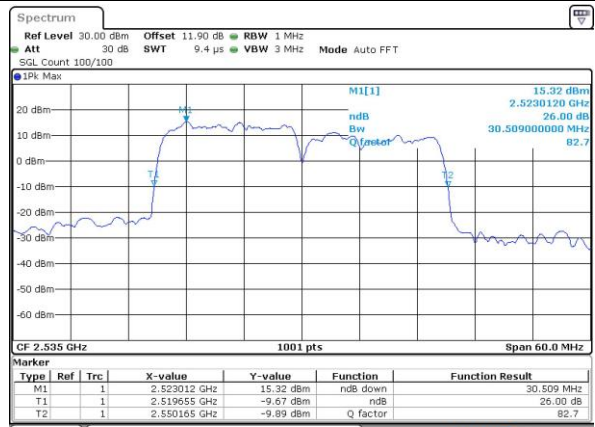

Date: 15.NOV.2018 22:23:37

Highest Channel / 15MHz+10MHz

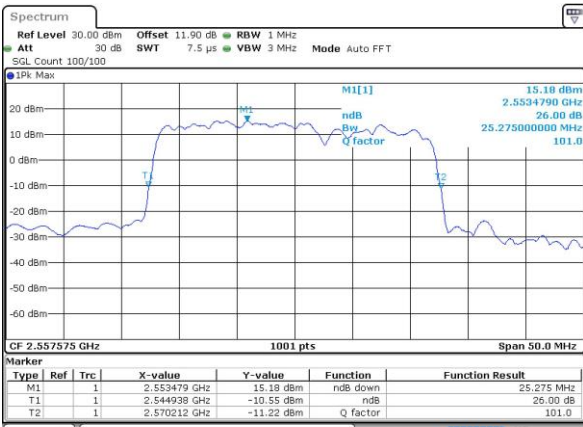

Date: 15.NOV.2018 23:51:50

Highest Channel / 15MHz+15MHz

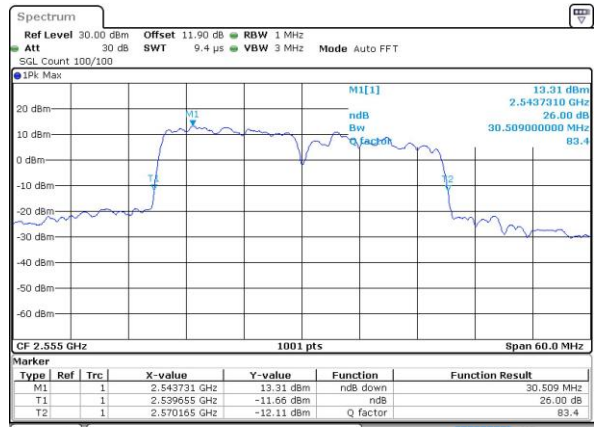

Date: 15.NOV.2018 22:35:32



LTE Band 7

16QAM

Lowest Channel / 15MHz+20MHz

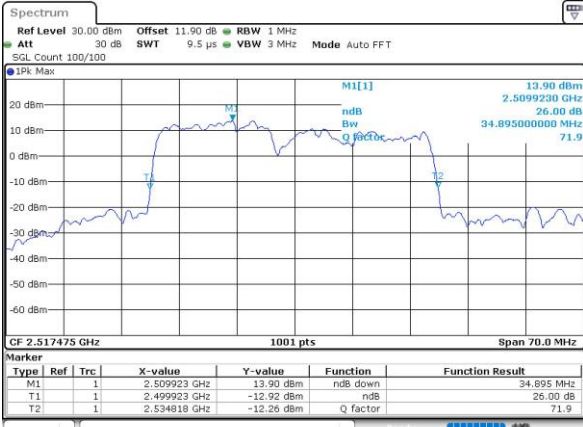

Date: 15.NOV.2018 15:40:20

Lowest Channel / 20MHz+10MHz

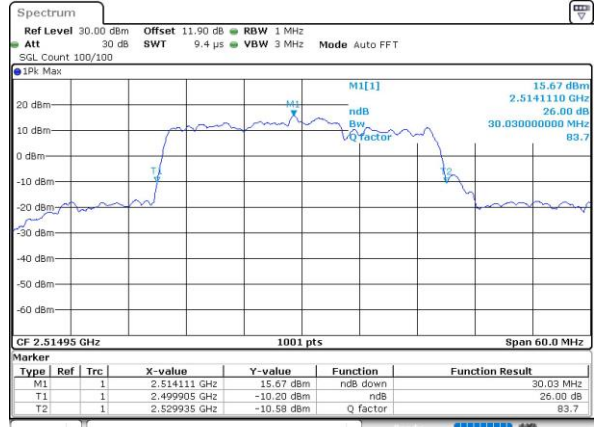

Date: 15.NOV.2018 14:36:54

Middle Channel / 15MHz+20MHz

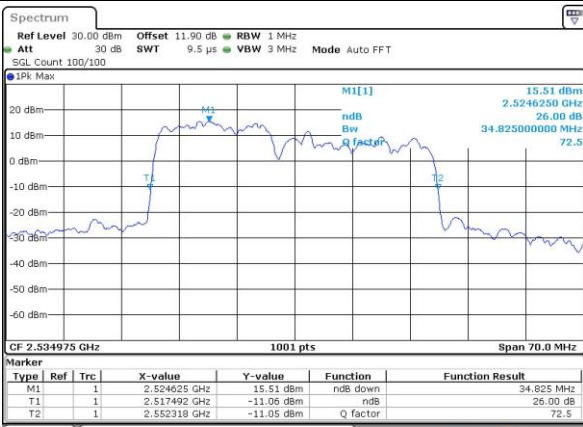

Date: 15.NOV.2018 15:58:52

Middle Channel / 20MHz+10MHz

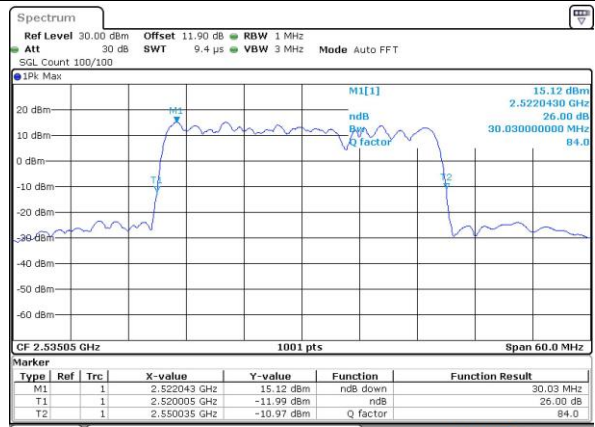

Date: 15.NOV.2018 14:55:26

Highest Channel / 15MHz+20MHz

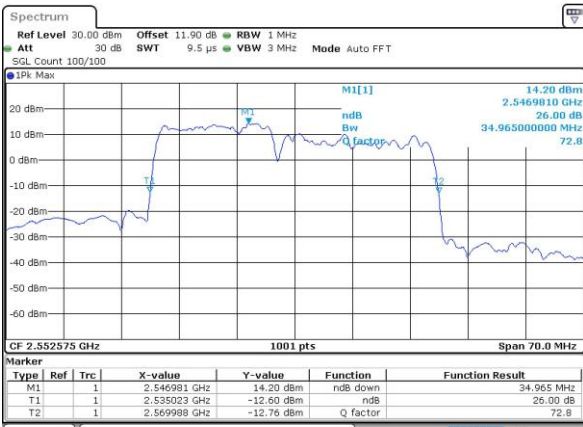

Date: 15.NOV.2018 16:51:22

Highest Channel / 20MHz+10MHz

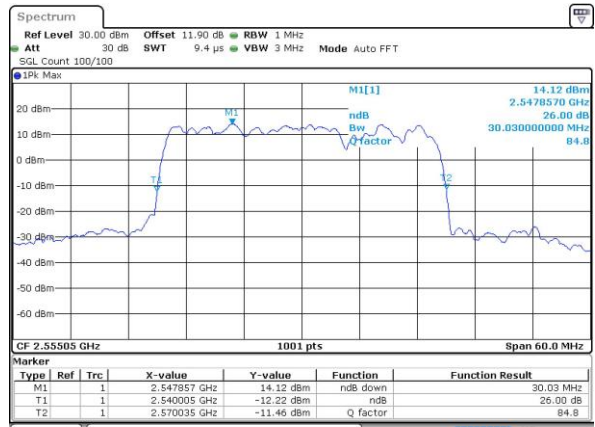

Date: 15.NOV.2018 15:07:07



LTE Band 7

16QAM

Lowest Channel / 20MHz+15MHz

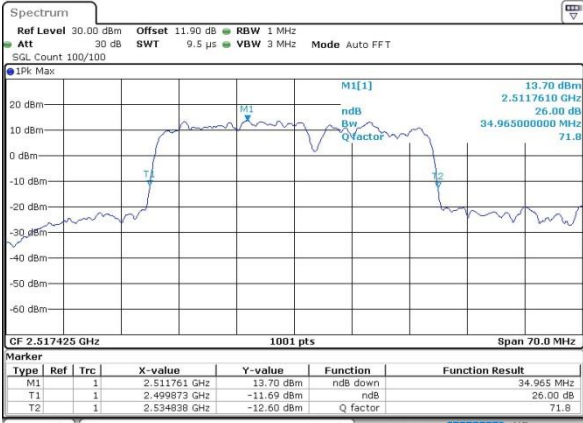

Date: 15.NOV.2018 13:09:01

Lowest Channel / 20MHz+20MHz

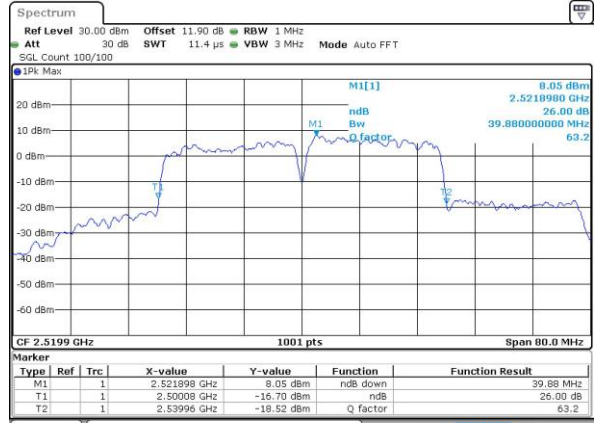

Date: 13.NOV.2018 14:20:20

Middle Channel / 20MHz+15MHz

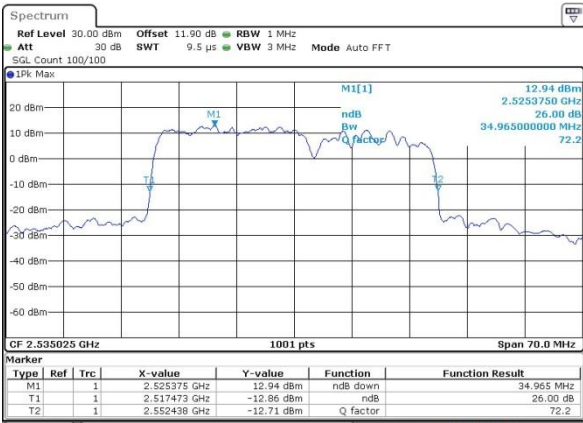

Date: 15.NOV.2018 13:21:24

Middle Channel / 20MHz+20MHz

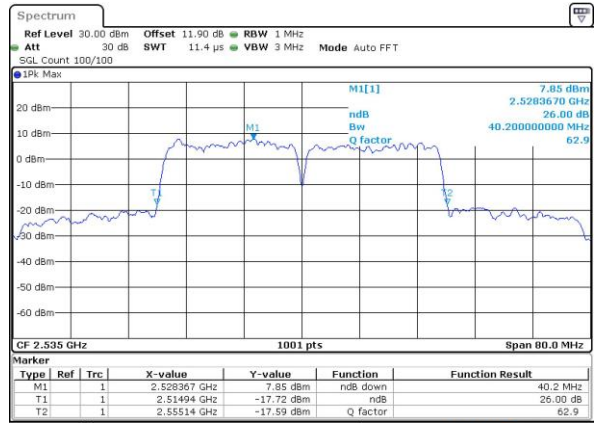

Date: 13.NOV.2018 14:26:48

Highest Channel / 20MHz+15MHz

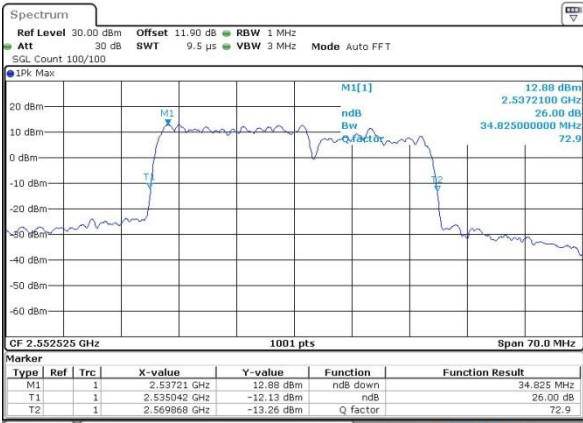

Date: 15.NOV.2018 13:33:45

Highest Channel / 20MHz+20MHz

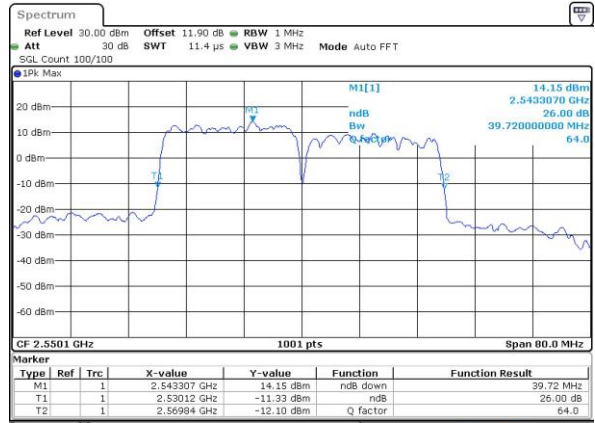

Date: 15.NOV.2018 14:00:31



LTE Band 7

64QAM

Lowest Channel / 10MHz+20MHz

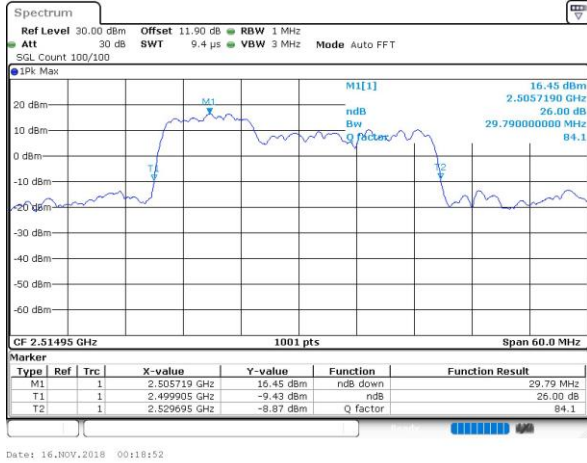

Middle Channel / 10MHz+20MHz

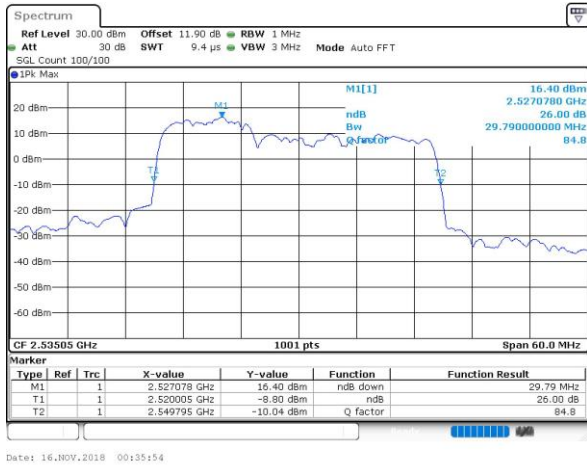

Highest Channel / 10MHz+20MHz

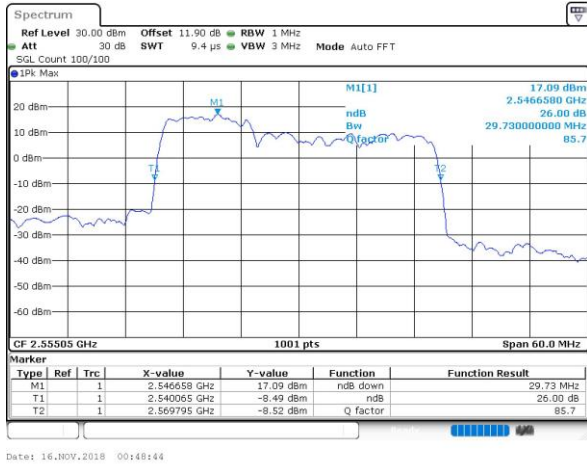



LTE Band 7

64QAM

Lowest Channel / 15MHz+10MHz

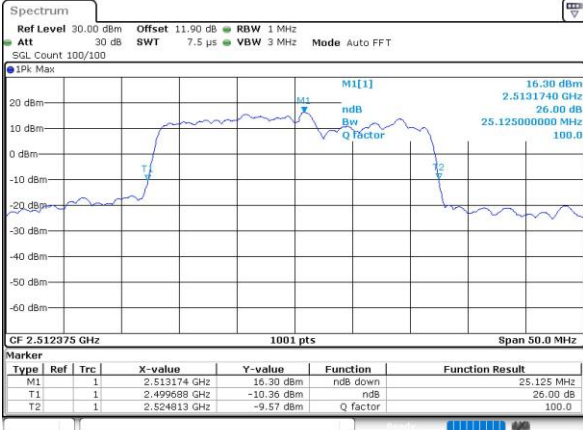

Date: 15.NOV.2018 23:23:08

Lowest Channel / 15MHz+15MHz

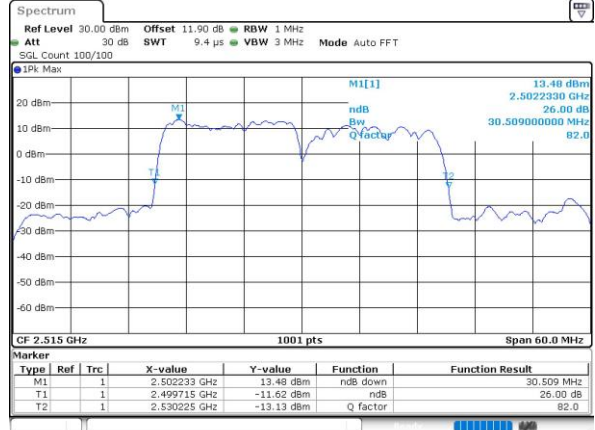

Date: 15.NOV.2018 17:15:28

Middle Channel / 15MHz+10MHz

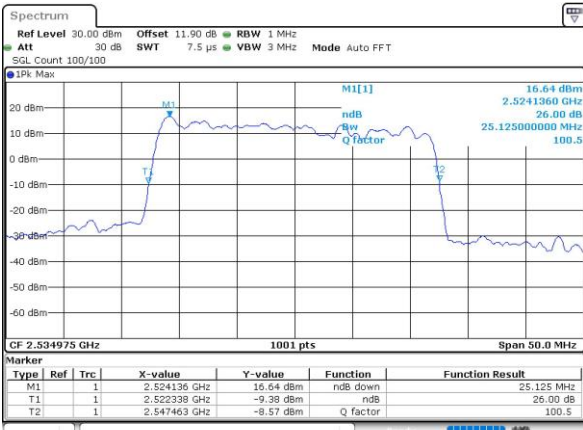

Date: 15.NOV.2018 23:39:27

Middle Channel / 15MHz+15MHz

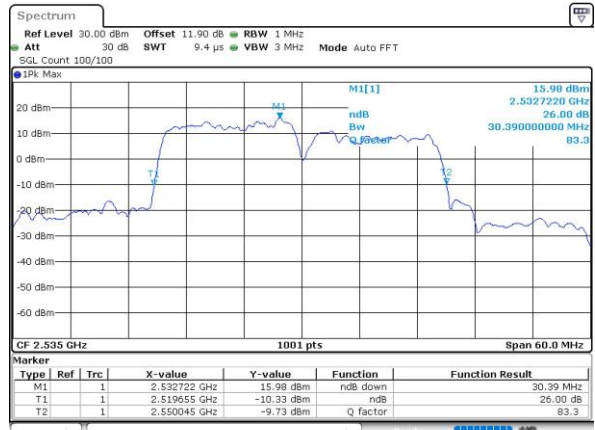

Date: 15.NOV.2018 22:12:10

Highest Channel / 15MHz+10MHz

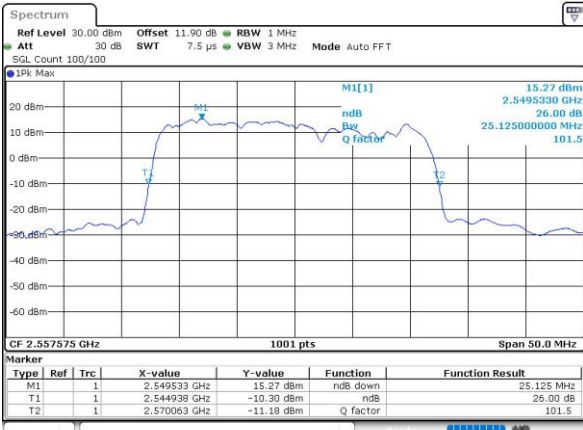

Date: 15.NOV.2018 23:52:16

Highest Channel / 15MHz+15MHz

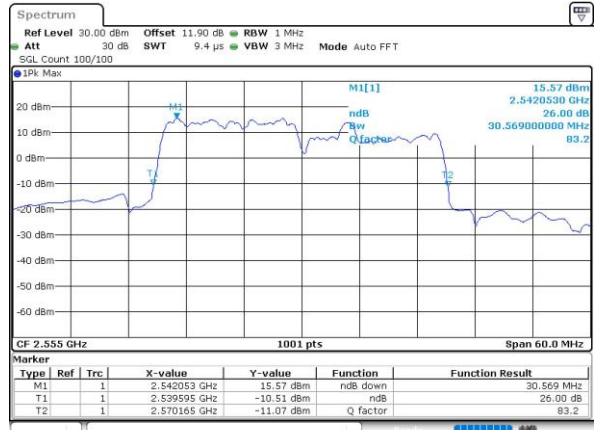

Date: 15.NOV.2018 22:35:59



LTE Band 7

64QAM

Lowest Channel / 15MHz+20MHz

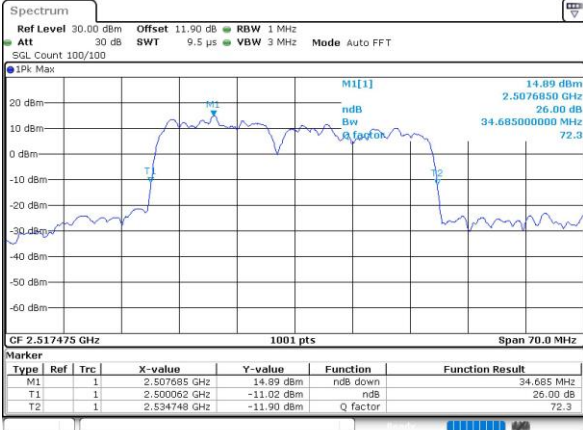

Date: 15.NOV.2018 15:39:53

Lowest Channel / 20MHz+10MHz

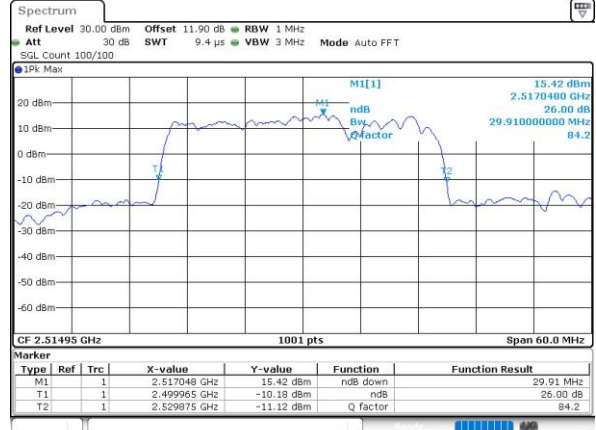

Date: 15.NOV.2018 14:36:28

Middle Channel / 15MHz+20MHz

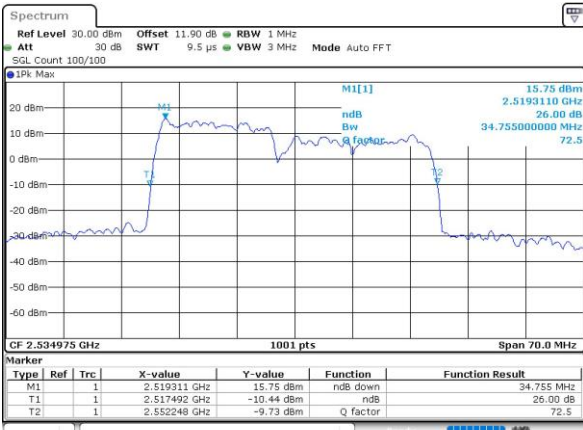

Date: 15.NOV.2018 15:58:26

Middle Channel / 20MHz+10MHz

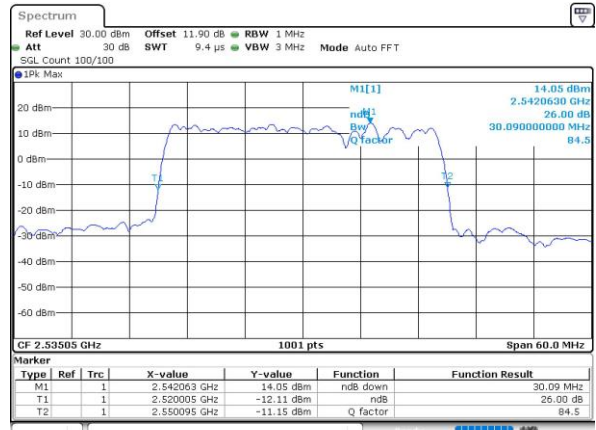

Date: 15.NOV.2018 14:55:00

Highest Channel / 15MHz+20MHz

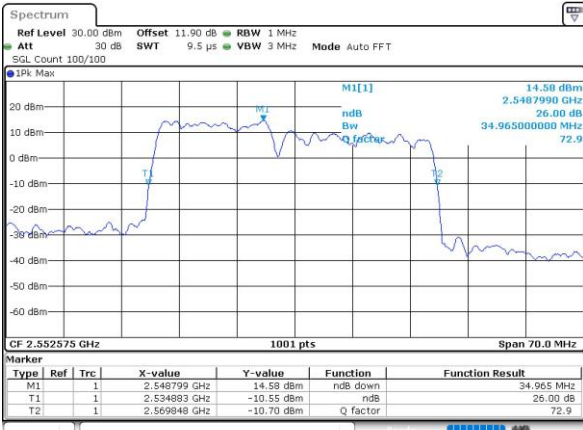

Date: 15.NOV.2018 16:51:49

Highest Channel / 20MHz+10MHz

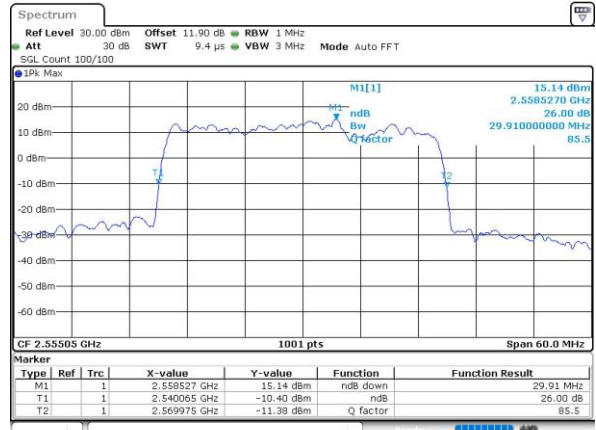

Date: 15.NOV.2018 15:07:34



LTE Band 7

64QAM

Lowest Channel / 20MHz+15MHz

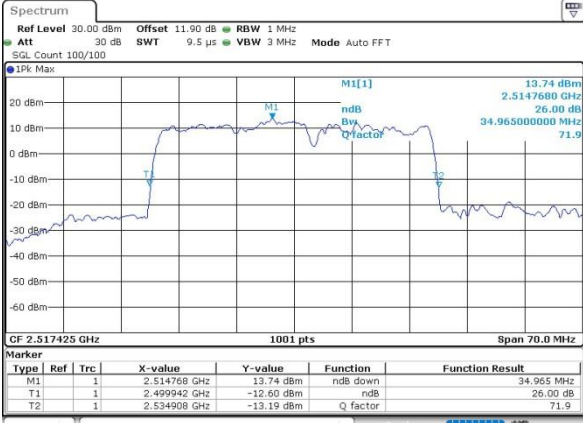

Date: 15.NOV.2018 13:08:35

Lowest Channel / 20MHz+20MHz

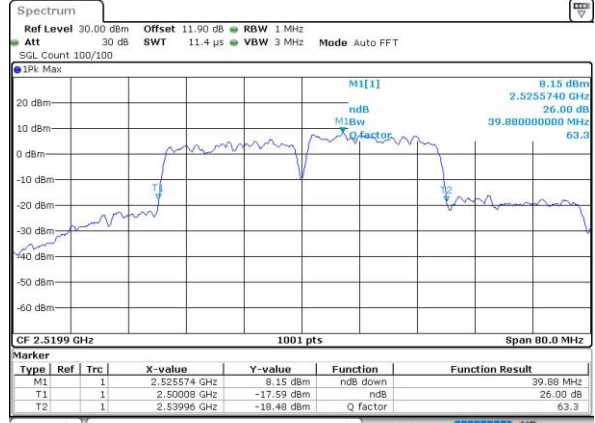

Date: 13.NOV.2018 14:19:54

Middle Channel / 20MHz+15MHz

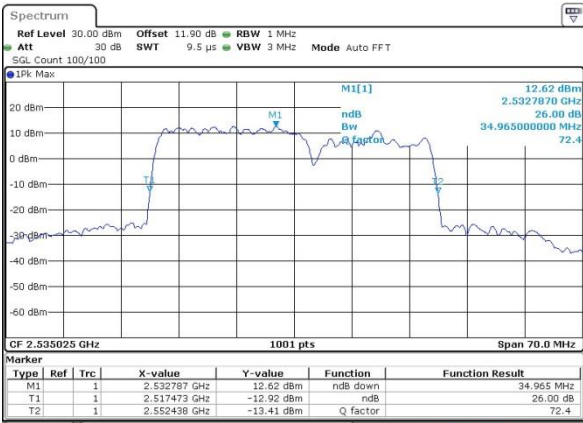

Date: 15.NOV.2018 13:20:57

Middle Channel / 20MHz+20MHz

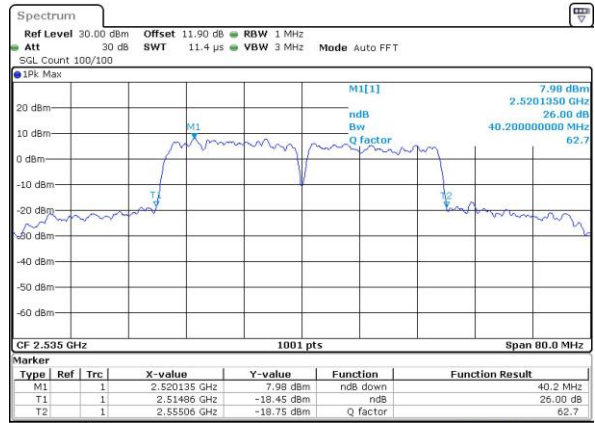

Date: 13.NOV.2018 14:19:22

Highest Channel / 20MHz+15MHz

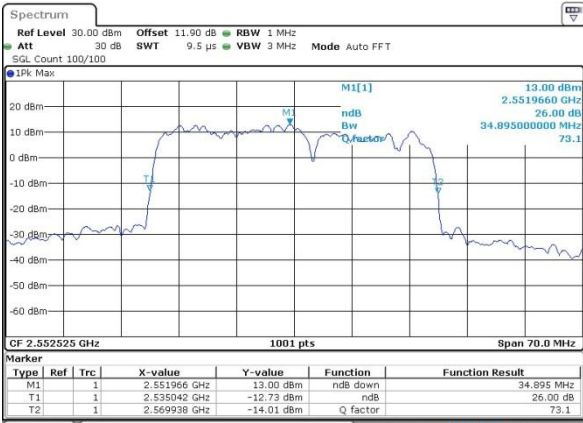

Date: 15.NOV.2018 13:34:11

Highest Channel / 20MHz+20MHz

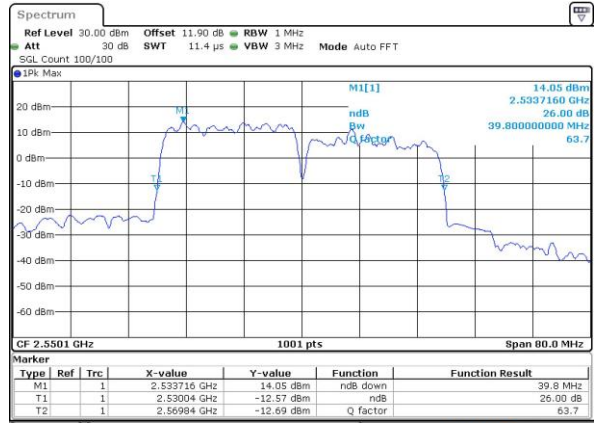

Date: 15.NOV.2018 14:00:57



Occupied Bandwidth

Mode	LTE Band 7 : 99%OBW(MHz)			
QPSK				
BW	10MHz+20MHz	15MHz+5MHz	15MHz+10MHz	15MHz+15MHz
Lowest CH	27.99	-	23.53	28.35
Middle CH	27.99	-	23.48	28.53
Highest CH	27.99	-	23.28	28.29
BW	15MHz+20MHz	20MHz+10MHz	20MHz+15MHz	20MHz+20MHz
Lowest CH	32.52	27.99	32.52	37.72
Middle CH	32.59	28.17	32.80	37.96
Highest CH	32.31	27.87	32.73	37.40

Mode	LTE Band 7 : 99%OBW(MHz)			
16QAM				
BW	10MHz+20MHz	15MHz+5MHz	15MHz+10MHz	15MHz+15MHz
Lowest CH	28.11	-	23.23	28.59
Middle CH	28.23	-	23.73	28.53
Highest CH	27.69	-	23.28	28.05
BW	15MHz+20MHz	20MHz+10MHz	20MHz+15MHz	20MHz+20MHz
Lowest CH	32.80	27.75	32.87	37.80
Middle CH	33.01	27.81	32.87	37.88
Highest CH	31.96	28.05	32.52	37.96

Mode	LTE Band 7 : 99%OBW(MHz)			
64QAM				
BW	10MHz+20MHz	15MHz+5MHz	15MHz+10MHz	15MHz+15MHz
Lowest CH	27.93	-	23.38	28.53
Middle CH	28.17	-	23.18	28.59
Highest CH	27.81	-	23.53	28.41
BW	15MHz+20MHz	20MHz+10MHz	20MHz+15MHz	20MHz+20MHz
Lowest CH	32.94	27.99	33.01	37.72
Middle CH	32.87	28.29	32.94	37.88
Highest CH	32.66	27.99	32.87	37.72



LTE Band 7

QPSK

Lowest Channel / 10MHz+20MHz

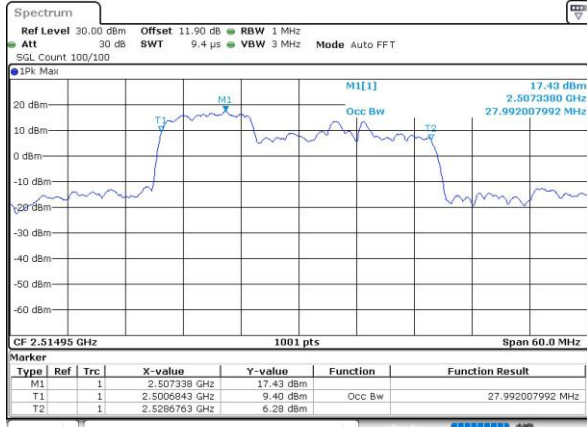

Date: 16.NOV.2018 00:17:33

Middle Channel / 10MHz+20MHz

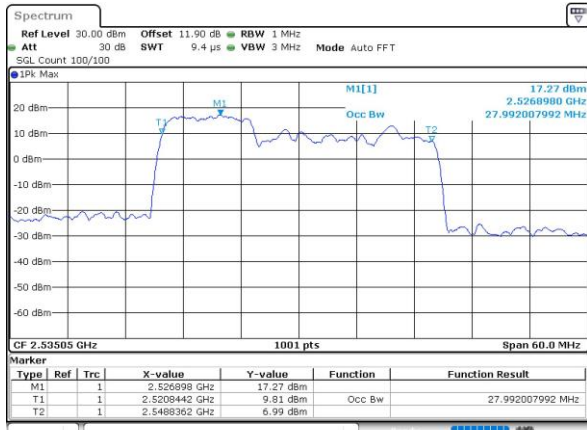

Date: 16.NOV.2018 00:34:35

Highest Channel / 10MHz+20MHz

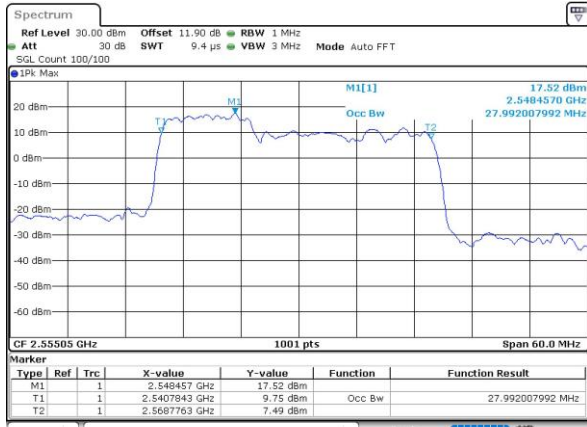

Date: 16.NOV.2018 00:47:25



LTE Band 7

QPSK

Lowest Channel / 15MHz+10MHz

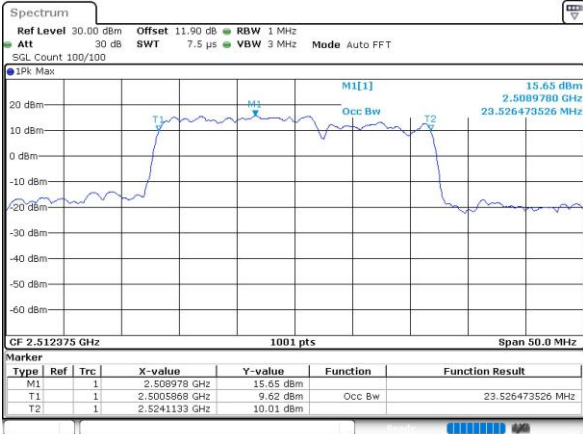

Date: 15.NOV.2018 23:21:50

Lowest Channel / 15MHz+15MHz

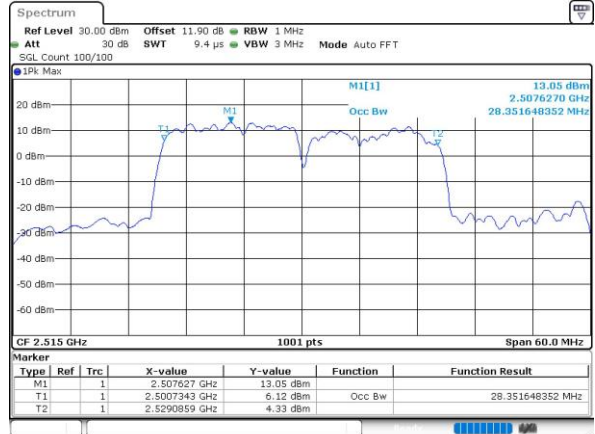

Date: 15.NOV.2018 17:14:09

Middle Channel / 15MHz+10MHz

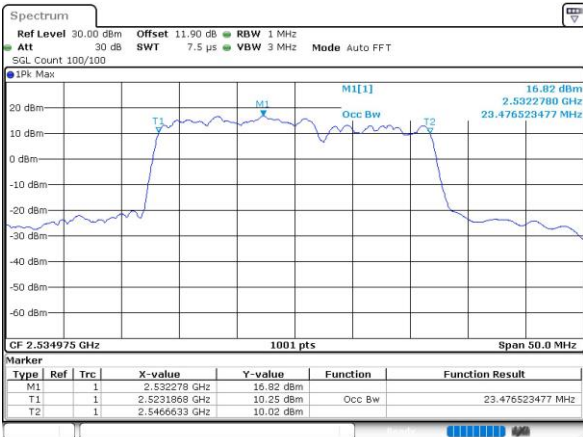

Date: 15.NOV.2018 23:38:09

Middle Channel / 15MHz+15MHz

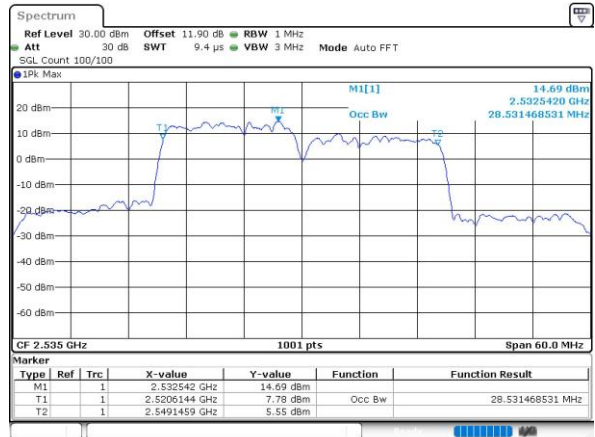

Date: 15.NOV.2018 22:21:52

Highest Channel / 15MHz+10MHz

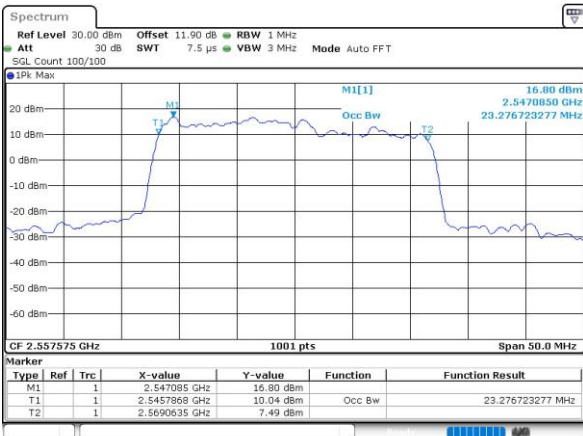

Date: 15.NOV.2018 23:50:58

Highest Channel / 15MHz+15MHz

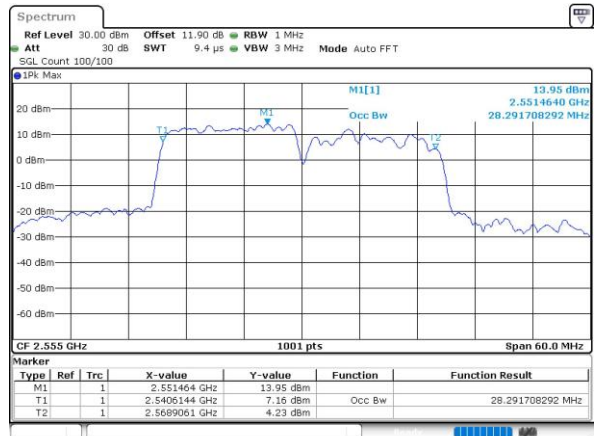

Date: 15.NOV.2018 22:34:39



LTE Band 7

QPSK

Lowest Channel / 15MHz+20MHz

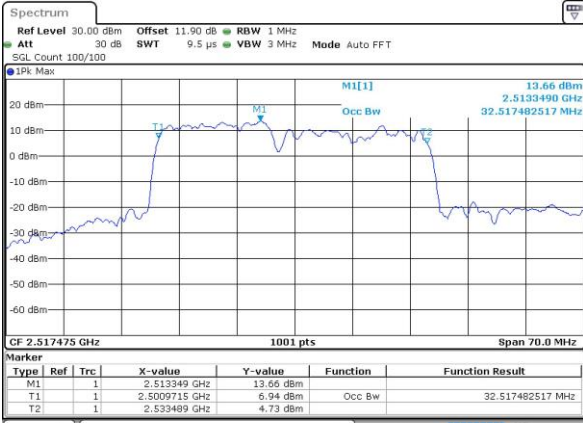

Date: 15.NOV.2018 15:38:34

Lowest Channel / 20MHz+10MHz

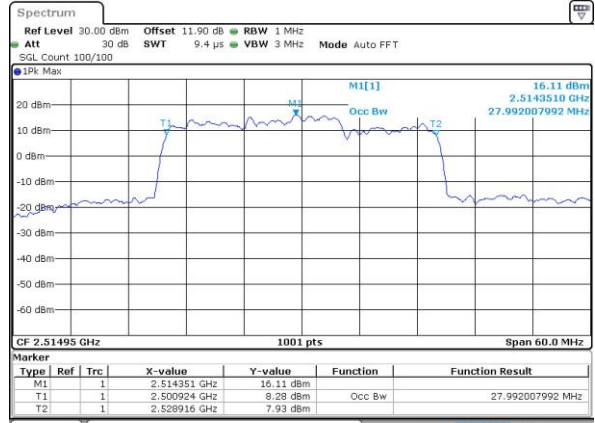

Date: 15.NOV.2018 14:35:08

Middle Channel / 15MHz+20MHz

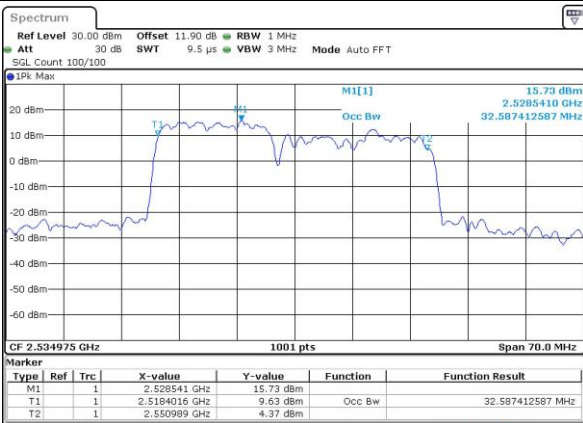

Date: 15.NOV.2018 15:57:06

Middle Channel / 20MHz+10MHz

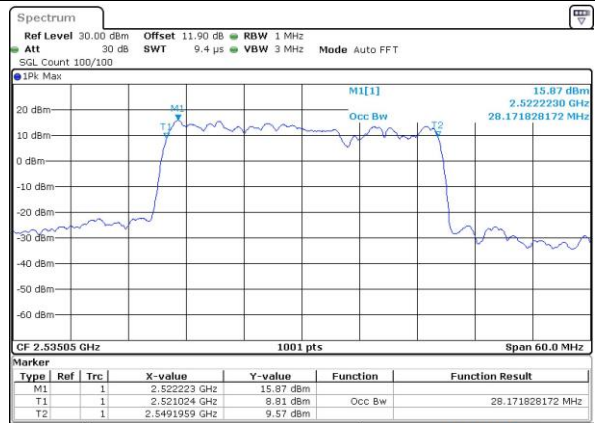

Date: 15.NOV.2018 14:53:41

Highest Channel / 15MHz+20MHz

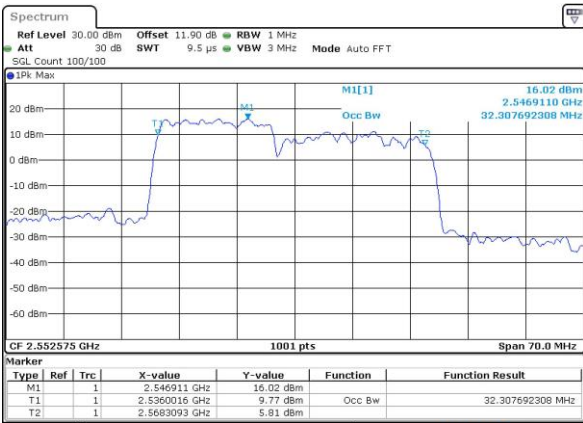

Date: 15.NOV.2018 16:50:30

Highest Channel / 20MHz+10MHz

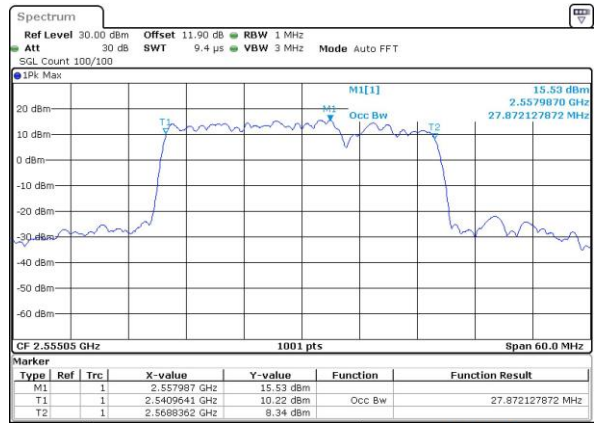

Date: 15.NOV.2018 15:06:15



LTE Band 7

QPSK

Lowest Channel / 20MHz+15MHz

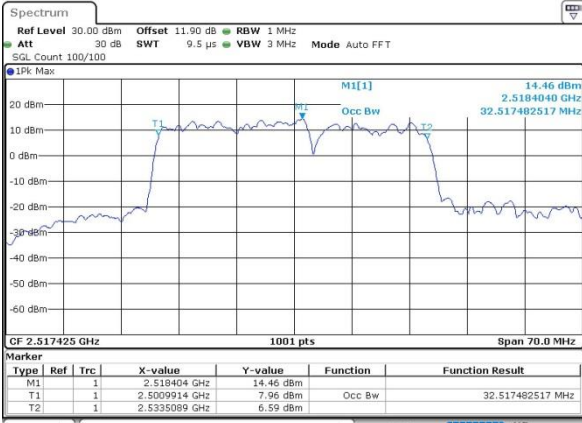

Date: 15.NOV.2018 13:07:16

Lowest Channel / 20MHz+20MHz

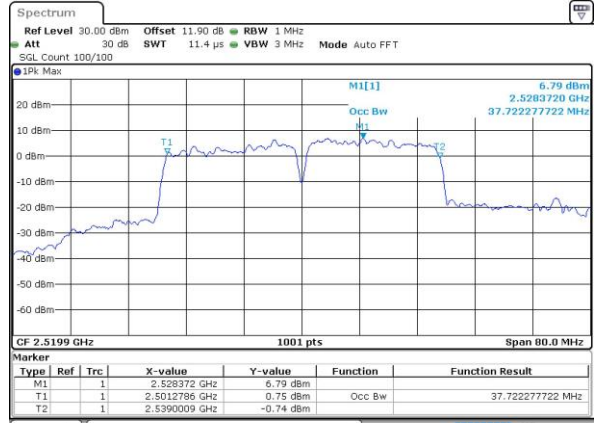

Date: 13.NOV.2018 14:18:35

Middle Channel / 20MHz+15MHz

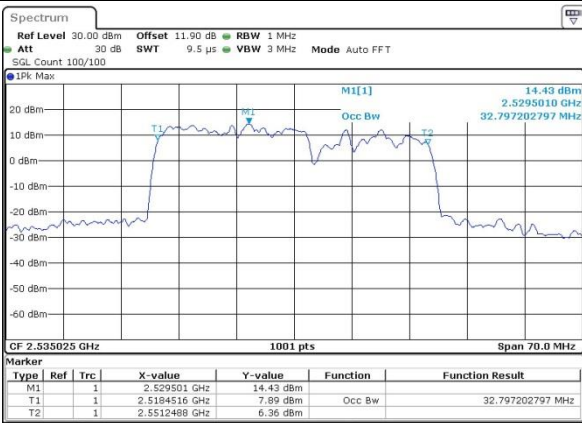

Date: 15.NOV.2018 13:19:38

Middle Channel / 20MHz+20MHz

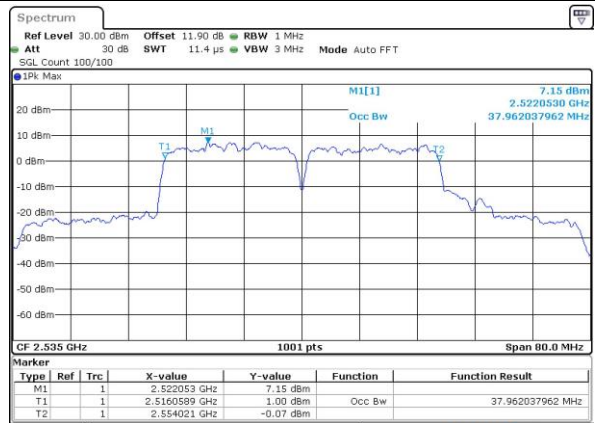

Date: 13.NOV.2018 14:13:04

Highest Channel / 20MHz+15MHz

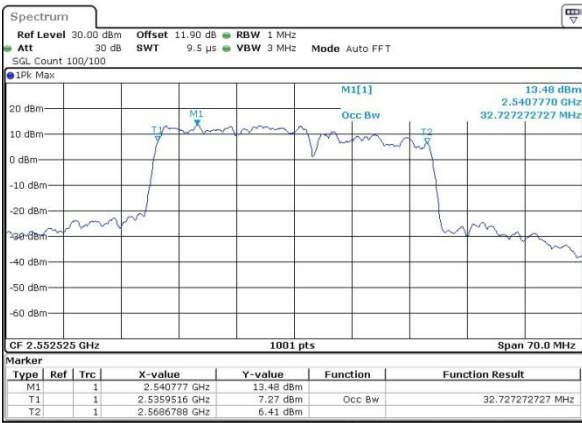

Date: 15.NOV.2018 13:32:52

Highest Channel / 20MHz+20MHz

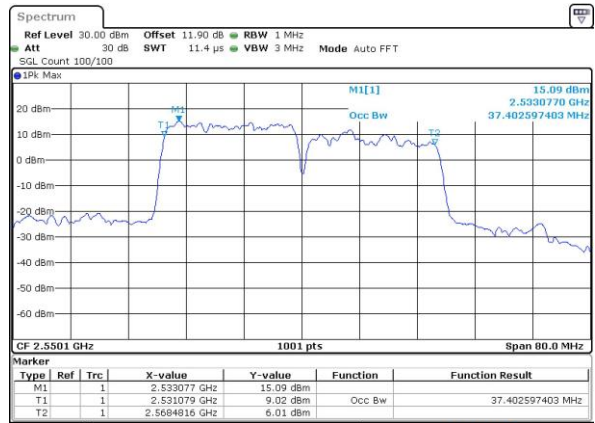

Date: 15.NOV.2018 14:19:31



LTE Band 7

16QAM

Lowest Channel / 10MHz+20MHz

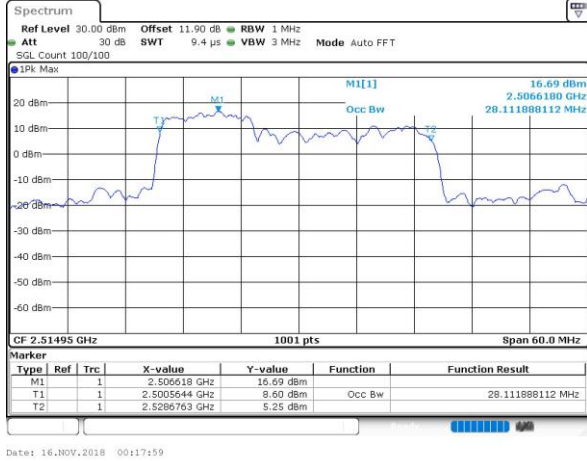

Date: 16.NOV.2018 00:17:59

Middle Channel / 10MHz+20MHz

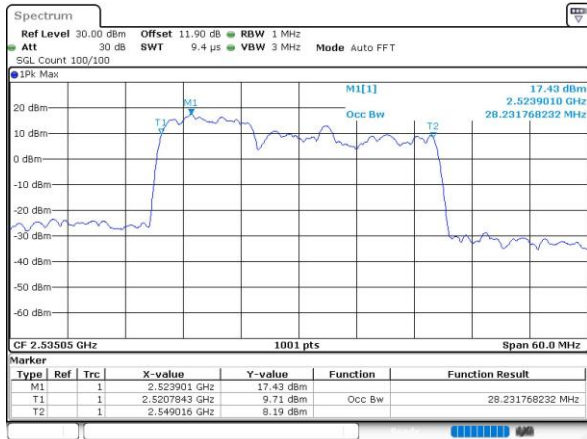

Date: 16.NOV.2018 00:35:01

Highest Channel / 10MHz+20MHz

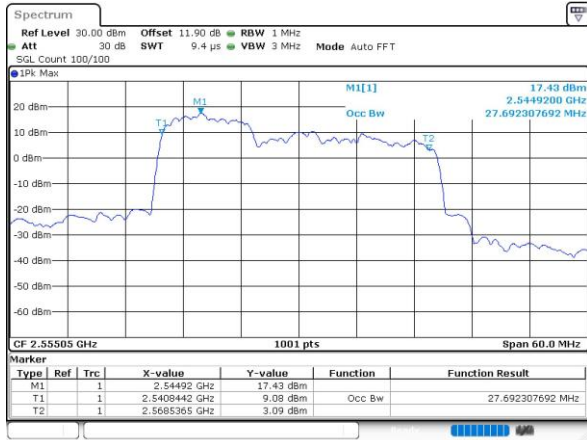

Date: 16.NOV.2018 00:46:59