

All product names, trademarks, and registered trademarks are property of their respective owners. All company, product, and service names used in this document are for identification purposes only. Use of these names, trademarks, and brands does not imply endorsement.

The Bluetooth® word mark and logos are registered trademarks owned by Bluetooth SIG, Inc., used under license.

Brookstone® trademark, name and logos are trademarks of BKST Brand Holdings LLC and used under license.  
 Manufactured and Marked by Southern Telecom, Inc. under license.

Southern Telecom  
 Brooklyn, NY 11220

Model No.: BSSK9000

1-877-668-4839 (Toll Free)  
 Monday - Friday: 8AM - 10PM (EST)

**Brookstone®**

**AmbientAudio**

Speaker & LED  
 Wall Panel System

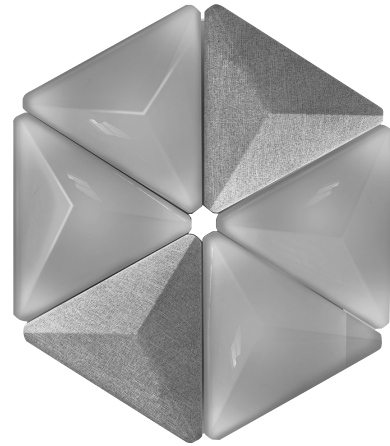

**TABLE OF CONTENTS**

Warnings and Cautions.....1  
 FCC Information.....4  
 Introduction.....5  
 Location of Controls.....6  
 Connecting the Brackets.....8  
 Installing & Setup.....10  
 Using the System.....14  
 Warranty Information.....16

**In the Box**

- Main Speaker Panel (x1)
- Secondary Speaker Panel (x1)
- LED Wall Panel (x4)
- Power Adapter (x1)
- Remote Control w/CR2025 battery (x1)
- Mounting Brackets
- Mounting Equipment
- Instruction Manual

**Warranty (cont'd)**

NO WARRANTIES, WHETHER EXPRESS OR IMPLIED, INCLUDING, BUT NOT LIMITED TO, ANY IMPLIED WARRANTIES OF MERCHANTABILITY OR FITNESS FOR A PARTICULAR PURPOSE, OTHER THAN THOSE EXPRESSLY DESCRIBED ABOVE SHALL APPLY. DISTRIBUTOR FURTHER DISCLAIMS ALL WARRANTIES AFTER THE EXPRESS WARRANTY PERIOD STATED ABOVE. NO OTHER EXPRESS WARRANTY OR GUARANTY GIVEN BY ANY PERSON, FIRM OR ENTITY WITH RESPECT TO THE PRODUCT SHALL BE BINDING ON DISTRIBUTOR. REPAIR, REPLACEMENT, OR REFUND OF THE ORIGINAL PURCHASE PRICE - AT DISTRIBUTOR'S SOLE DISCRETION - ARE THE EXCLUSIVE REMEDIES OF THE CONSUMER. IN NO EVENT WILL DISTRIBUTOR OR ITS MANUFACTURERS BE LIABLE FOR ANY INCIDENTAL, DIRECT, INDIRECT, SPECIAL, PUNITIVE OR CONSEQUENTIAL DAMAGES (SUCH AS, BUT NOT LIMITED TO, DAMAGES FOR LOSS OF PROFITS, BUSINESS, SAVINGS, DATA OR RECORDS) CAUSED BY THE USE, MISUSE OR INABILITY TO USE THE PRODUCT. EXCEPT AS STATED HEREIN, NO OTHER WARRANTIES SHALL APPLY. NOTWITHSTANDING THE FOREGOING, CONSUMER'S RECOVERY AGAINST DISTRIBUTOR SHALL NOT EXCEED THE PURCHASE PRICE OF THE PRODUCT SOLD BY DISTRIBUTOR. THIS WARRANTY SHALL NOT EXTEND TO ANYONE OTHER THAN THE ORIGINAL CONSUMER WHO PURCHASED THE PRODUCT AND IS NOT TRANSFERABLE.

Some countries, states or provinces do not allow the exclusion or limitation of incidental or consequential damages or allow limitations on warranties, so limitation or exclusions may not apply to you. This warranty gives you specific legal rights, and you may have other rights that vary from state to state or province to province. Contact your authorized retailer to determine if another warranty applies.

## Warranty Information

1-Year Limited Warranty  
Territory: United States/Canada

### LIMITED WARRANTY TO ORIGINAL CONSUMER

This product (including any accessories included in the original packaging) as supplied and distributed new by an authorized retailer is warranted by Southern Telecom, Inc. to the original consumer purchaser against defects in materials and workmanship ("Warranty") as follows:

To obtain warranty service:

- Visit our website at [www.southern telecom.com](http://www.southern telecom.com)
- Click on **Product Support**
- Select the **Brand** of your device
- Select **Service Request** and fill out the form to begin your inquiry

Or call the Customer Support number below

1-877-668-4839 (Toll Free)  
Monday - Friday: 8AM - 10PM (EST)

Your product will be repaired or replaced, at our option, for the same or similar model of equal value if examination by the service center determines this product is defective. Products received damaged as a result of shipping will require you to file a claim with the carrier.

Warranty service not provided

This warranty does not cover damage resulting from accident, misuse, abuse, improper installation or operation, lack of reasonable care, unauthorized modification including software modifications such as the installation of custom firmware. This warranty is voided in the event any unauthorized person opens, alters or repairs this product. All products being returned to the authorized service center for repair must be suitably packaged.

16

## CAUTION

- TO REDUCE THE RISK OF ELECTRIC SHOCK, DO NOT REMOVE COVER. THERE ARE NO SERVICEABLE PARTS INSIDE.
- TO REDUCE THE RISK OF FIRE OR ELECTRIC SHOCK, DO NOT EXPOSE THIS UNIT TO RAIN OR MOISTURE.



The lightning flash with arrow-head symbol within an equilateral triangle is intended to alert the user to the presence of uninsulated "dangerous voltage" within the unit's enclosure that may be of sufficient magnitude to constitute a risk of electric shock.



The exclamation point within an equilateral triangle is intended to alert the user to the presence of important operating and maintenance (servicing) instructions in the literature accompanying the unit.

## IMPORTANT SAFETY INSTRUCTIONS

All the safety and operating instructions should be read, heeded, adhered to and followed before the unit is operated.

1

## Rating Label Definitions

Direct current symbol.



This symbol signifies that this is a wireless device powered by Bluetooth® technology. The Bluetooth® word mark and logos are registered trademarks owned by Bluetooth SIG, Inc., used under license.

## SAVE THESE INSTRUCTIONS!

### DANGER

To reduce the risk of electric shock, burns, fire or injury:

1. Do not use while bathing or in a shower.
2. Do not place or store unit where it can fall or be pulled into a tub or sink.
3. Do not place in, drop or submerge in water or other liquid.
4. Do not reach for a unit that has fallen into water. Unplug it immediately.
5. Care should be taken so that objects do not fall and liquids are not spilled onto the unit.

### WARNING

1. Close supervision is necessary when this appliance/product is used by or near children or mentally disabled individuals.
2. Use this unit only for its intended use as described in this manual.
3. Unplug this unit during lightning storms or when unused for long periods of time.
4. Never drop or insert an object into any opening.

2

## Using the Lights

- Press the [LED] button on the side of the main speaker or the [M] button on the remote control to turn the lights ON.
- Continue pressing the [LED] or [M] buttons to cycle through the light modes and turn OFF.
- When using the reactive light modes, where the lights will dance to the beat of your music, increase the volume of your paired device for best results.

## Controlling Playback & Volume

- Press the [▶||] button on the remote control to pause/resume media playback.
- Press the [◀] and [▶] buttons to skip tracks.
- Press the [ + ] and [ - ] buttons to adjust volume.
- Press the [⏏] button to mute/unmute volume.

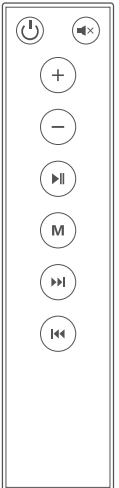

15

## Using the System

### Power ON/OFF

- Press the [6] button on the side of the main speaker or the remote control to power the system ON. When powered ON, the LED light panels will turn on and the speaker will enter Bluetooth pairing mode, automatically re-pairing to any nearby previously-paired device that has Bluetooth enabled.
- Press the [6] button on the main speaker or the remote to power the system OFF.

### Bluetooth Pairing

1. Power the speaker ON. A tone will be heard.
2. Set your mobile device to search for Bluetooth devices. When it appears, select BSSK9000 from the list of found devices.
3. After a successful pairing, a tone will be heard again, indicating the system is paired.

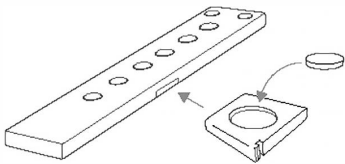

**Installing Remote Battery**  
The remote control will already have a CR2025 battery installed, just remove the plastic tab sticking out of the compartment.

To replace a battery, remove the compartment from the side of the remote control. Place a new CR2025 battery with the polarity facing up and slide the compartment back in so that it clips into place.

5. Protect the power cord from being walked on or pinched, particularly at plug outlets, convenience receptacles and the point where it exits the unit.
6. Do not allow cord to touch hot surfaces. Wrap cord loosely around the unit when storing.
7. The unit should be situated away from direct sunlight or heat sources such as radiators, electric heaters, heat registers, stoves, or other units (including amplifiers) that produce heat. Avoid placing on top of stereo equipment that radiates heat.
8. Do not overload the electrical outlet. Use only the power source as indicated.
9. Do not carry this unit by its cord or use the cord as a handle.
10. Never operate this unit if it has a damaged cord or plug, if it is not working properly, or if it has been dropped or damaged, do not attempt to fix it yourself.
11. To avoid the risk of electric shock, do not disassemble or attempt to repair the unit. Incorrect repair can cause risk of electric shock or injury to persons when the unit is used.
12. Do not operate in the presence of explosive and/or flammable fumes.
13. Never remove the plug from the outlet by pulling the power cord.

## FCC Information

**Caution:** Any changes or modifications not expressly approved by the party responsible for compliance could void the user's authority to operate the equipment.

**Note:** This equipment has been tested and found to comply with the limits for a Class B digital device, pursuant to part 15 of the FCC Rules. These limits are designed to provide reasonable protection against harmful interference in a residential installation. This equipment generates, uses and can radiate radio frequency energy and, if not installed and used in accordance with the instructions, may cause harmful interference to radio communications. However, there is no guarantee that interference will not occur in a particular installation. If this equipment does cause harmful interference to radio or television reception, which can be determined by turning the equipment off and on, the user is encouraged to try to correct the interference by one or more of the following measures:

- Reorient or relocate the receiving antenna.
- Increase the separation between the equipment and receiver.
- Connect the equipment into an outlet on a circuit different from that to which the receiver is connected.
- Consult the dealer or an experienced radio/TV technician for help.

This device complies with Part 15 of the FCC Rules. Operation is subject to the following two conditions: (1) This device may not cause harmful interference, and (2) this device must accept any interference received, including interference that may cause undesired operation.

### Radiation Exposure Information

This device has been evaluated to meet general RF exposure requirements. The device can be used in portable exposure conditions without restriction.

The LED panel has a single position pin hole that can only be connected to a bracket in a single orientation. The Main speaker panel has a single, central position pin hole and the Secondary speaker panel has multiple position pin holes, and can be connected to the bracket in any orientation.

**Note:** The main speaker **MUST** be connected to the main speaker bracket. The bracket will be marked with a sticker.

1. Connect a panel by placing on the bracket, aligning the position pin and position pin hole then firmly pressing down, making sure that the metal contact pin sections are fully touching the wall bracket connectors.

2. Continue connecting the other speaker and light panels. Make sure the unit is completely connected and that all three metal contact pin sections are fully touching the wall bracket connectors.

3. Once finished, insert the pin of the supplied power adapter into the DC power input jack on the corner of the main speaker. Plug the adapter into an electrical wall outlet.

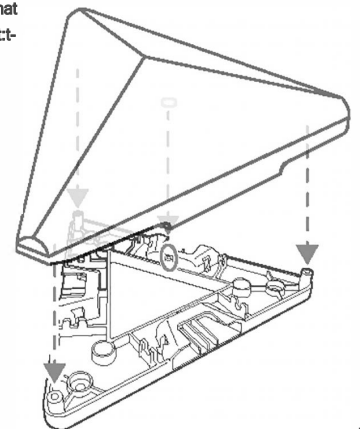

### Connecting the Speakers & Lights

Once the brackets are mounted you can begin connecting the panels. Each bracket has a position pin which fits into the position pin hole on each panel.

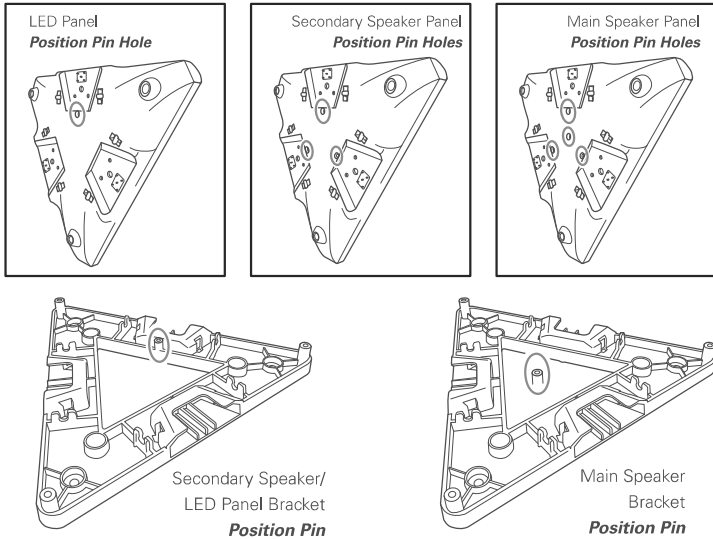

### Introduction

Thank you for purchasing the **AmbientAudio** speaker system from Brookstone! The **AmbientAudio** is a fully modular set of speaker- and LED- wall panels that can be organized into any configuration you can think of.

### How Does it Work?

The speaker & LED wall panel system is connected with wall brackets and bracket connectors. On the underside of each wall panel is a small section of metal contact pins (fig.1) that make contact with corresponding contact pads on a bracket connector (fig. 2).

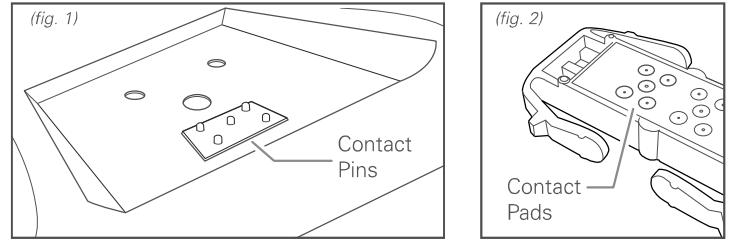

When the bracket connectors are clipped into place, power is carried through the whole system. **If one connector is not properly connected then there will be no power to the rest of the system.**



### Location of Controls

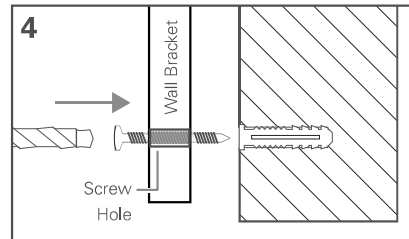
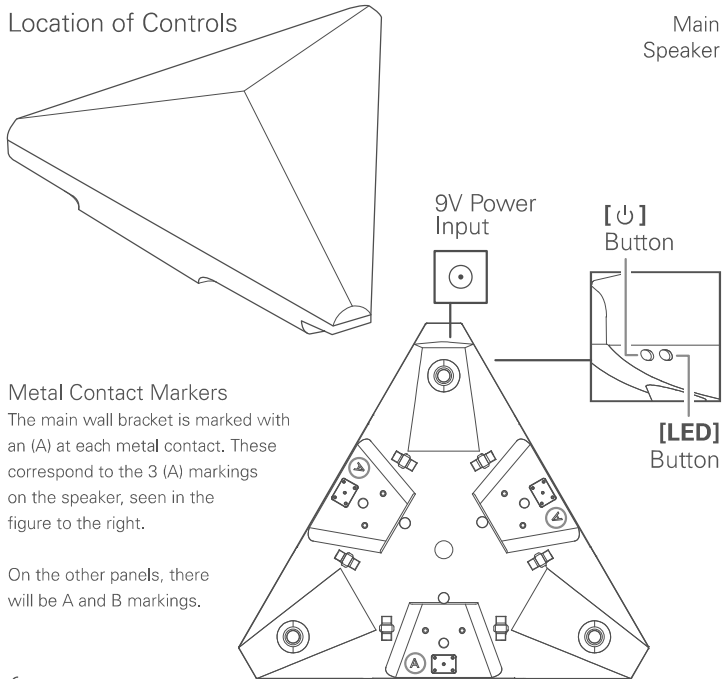

4. Place the wall brackets back on the wall and carefully drill them into the anchors using the mounting screws.

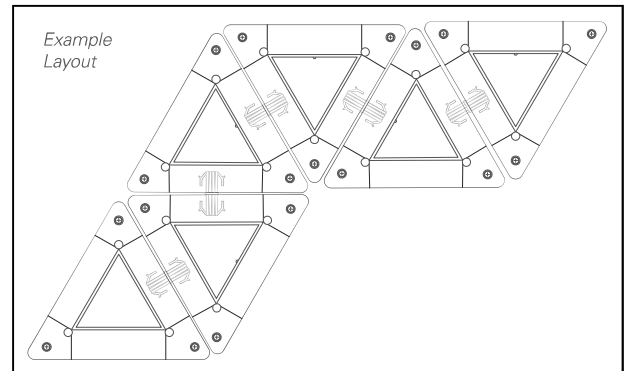

## Installation & Setup

Before drilling any holes, make sure that the area you plan on mounting your speaker system is near a working electrical outlet, and that you will be able to plug the adapter into the main speaker and the outlet. **Make sure that the controls on the Main speaker panel will be accessible once mounted.**

1. Once you have constructed your wall brackets, place them in the location they will be mounted. Using a pencil, mark all 3 screw holes on each bracket.

**Note:** It is HIGHLY recommended that you use the wall brackets as a guide to mark the holes. This will ensure that there are no incorrect measurements!

2. Set the wall brackets aside and, using a power drill, drill at each pencil mark.
3. Insert the supplied plastic anchors into the holes.

10

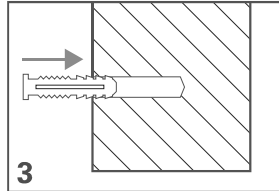
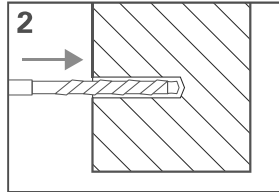
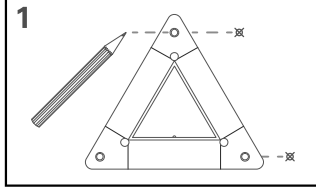

## Wall Bracket

**NOTE:** Pictured below is the standard wall bracket that fits any of the LED panels and the secondary speaker panel. 5 standard brackets are provided with the system, the 6th bracket is ONLY used for the main speaker panel. All panels and brackets will be marked.

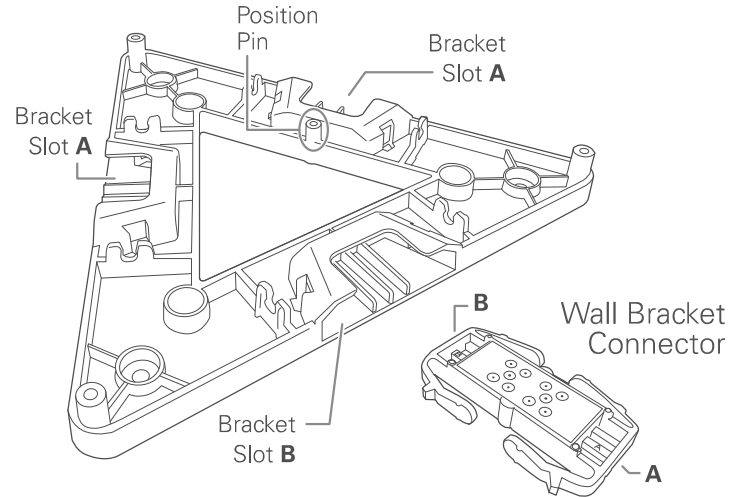

7

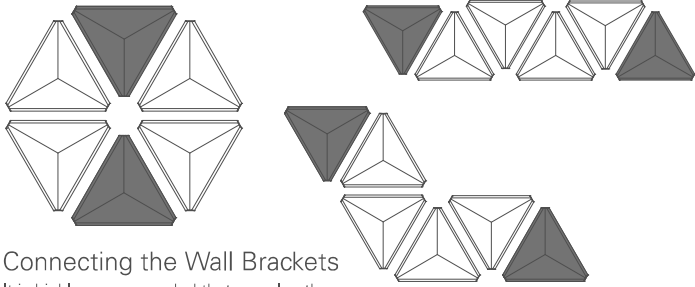

## Connecting the Wall Brackets

It is highly recommended that you plan the layout you want for your AmbientAudio system BEFORE mounting the brackets and connecting the speakers.

Make sure that the area you plan on installing the system is clear of any objects or obstructions and is capable of maintaining the weight of the wall brackets and panels. Also make sure that there is a nearby electrical outlet to power the system!

1. Remove the AmbientAudio system from its packaging and collect all of the wall brackets and the bracket connectors.

8

**IMPORTANT:** Each bracket connector end is labeled A or B and can ONLY be connected to a corresponding A or B slot on the wall brackets.

### Correct

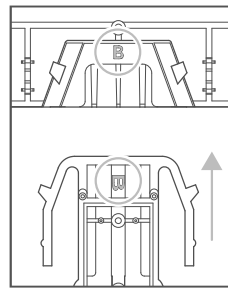

### Incorrect

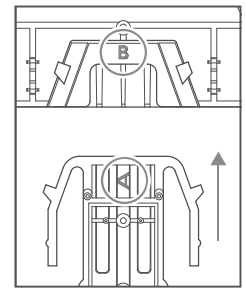

2. Take the main wall bracket and insert one of the bracket connectors into a slot. Make sure that the connector is **fully inserted** into the bracket and that it pops into place and cannot be pulled apart.

3. Continue connecting the wall brackets until you have achieved your desired layout.

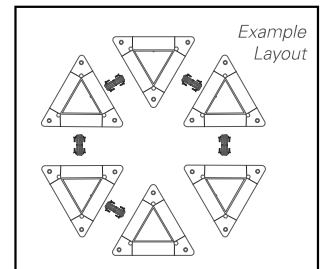

9