



FCC RF Test Report

APPLICANT : AzulFlower LLC
EQUIPMENT : Tablet PC
MODEL NAME : SL056ZE
FCC ID : 2AIP5-3975
STANDARD : FCC Part 15 Subpart E §15.407
CLASSIFICATION : (NII) Unlicensed National Information Infrastructure

This is a variant report. The testing was completed on Dec. 28, 2017. We, SPORTON INTERNATIONAL INC., would like to declare that the tested sample has been evaluated in accordance with the test procedures and has been in compliance with the applicable technical standards.

The test results in this report apply exclusively to the tested model / sample. Without written approval of SPORTON INTERNATIONAL INC., the test report shall not be reproduced except in full.

Reviewed by: Joseph Lin / Supervisor

Approved by: Jones Tsai / Manager



SPORTON INTERNATIONAL INC.

No. 52, Hwa Ya 1st Rd., Hwa Ya Technology Park, Kwei-Shan District, Tao Yuan City, Taiwan, R.O.C.

SPORTON INTERNATIONAL INC.

TEL : 886-3-327-3456

FAX : 886-3-328-4978

FCC ID : 2AIP5-3975

Page Number : 1 of 26

Report Issued Date : Feb. 02, 2018

Report Version : Rev. 01

Report Template No.: BU5-FR15EWLAC MA Version 2.0



TABLE OF CONTENTS

REVISION HISTORY.....3

SUMMARY OF TEST RESULT4

1 GENERAL DESCRIPTION5

 1.1 Applicant.....5

 1.2 Product Feature of Equipment Under Test.....5

 1.3 Product Specification of Equipment Under Test.....6

 1.4 Modification of EUT6

 1.5 Testing Location7

 1.6 Applicable Standards.....7

2 TEST CONFIGURATION OF EQUIPMENT UNDER TEST8

 2.1 Carrier Frequency and Channel8

 2.2 Test Mode.....9

 2.3 Connection Diagram of Test System.....10

 2.4 EUT Operation Test Setup10

 2.5 Measurement Results Explanation Example.....11

3 TEST RESULT.....12

 3.1 26dB & 99% Occupied Bandwidth Measurement12

 3.2 Maximum Conducted Output Power Measurement14

 3.3 Power Spectral Density Measurement16

 3.4 Unwanted Emissions Measurement.....18

 3.5 Automatically Discontinue Transmission23

 3.6 Antenna Requirements.....24

4 LIST OF MEASURING EQUIPMENT25

5 UNCERTAINTY OF EVALUATION26

APPENDIX A. CONDUCTED TEST RESULTS

APPENDIX B. RADIATED SPURIOUS EMISSION

APPENDIX C. RADIATED SPURIOUS EMISSION PLOTS

APPENDIX D. DUTY CYCLE PLOTS



REVISION HISTORY

REPORT NO.	VERSION	DESCRIPTION	ISSUED DATE
FR671336-04	Rev. 01	Initial issue of report	Feb. 02, 2018



SUMMARY OF TEST RESULT

Report Section	FCC Rule	Description	Limit	Result
3.1	2.1049 15.403(i)	26dB & 99% Bandwidth	-	Pass
3.2	15.407(a)	Maximum Conducted Output Power	≤ 24 dBm	Pass
3.3	15.407(a)	Power Spectral Density	≤ 11 dBm	Pass
3.4	15.407(b)	Unwanted Emissions	15.407(b) & 15.209(a)	Pass
-	15.207	AC Conducted Emission	15.207(a)	Not Required
3.5	15.407(c)	Automatically Discontinue Transmission	Discontinue Transmission	Pass
3.6	15.203 & 15.407(a)	Antenna Requirement	N/A	Pass

Note:

1. Not required means after assessing, test items are not necessary to carry out. which is covered by previous report
2. This is a variant report by adding band 2 and 3. All the test cases were performed on original report which can be referred to Sporton Report Number FR671336-01D. Based on the original report, the test cases were verified.



1 General Description

1.1 Applicant

AzulFlower LLC

10 Dorrance Street Suite 700 Providence, RI 02903

1.2 Product Feature of Equipment Under Test

Product Feature	
Equipment	Tablet PC
Model Name	SL056ZE
FCC ID	2AIP5-3975
EUT supports Radios application	WLAN 11b/g/n HT20 WLAN 11a/n HT20/HT40 WLAN 11ac VHT20/VHT40/VHT80 Bluetooth BR/EDR/LE



1.3 Product Specification of Equipment Under Test

Standards-related Product Specification	
Tx/Rx Frequency Range	5260 MHz ~ 5320 MHz 5500 MHz ~ 5720 MHz
Maximum Output Power to Antenna	<5260 MHz ~ 5320 MHz> 802.11a : 13.92 dBm / 0.0247 W 802.11n HT20 : 13.92 dBm / 0.0247 W 802.11n HT40 : 13.95 dBm / 0.0248 W 802.11ac VHT20 : 12.98 dBm / 0.0199 W 802.11ac VHT40 : 12.96 dBm / 0.0198 W 802.11ac VHT80 : 12.95 dBm / 0.0197 W <5500 MHz ~ 5720 MHz > 802.11a : 13.60 dBm / 0.0229 W 802.11n HT20 : 13.99 dBm / 0.0251 W 802.11n HT40 : 13.98 dBm / 0.0250 W 802.11ac VHT20 : 12.99 dBm / 0.0199 W 802.11ac VHT40 : 12.98 dBm / 0.0199 W 802.11ac VHT80 : 12.78 dBm / 0.019 W
99% Occupied Bandwidth	<5260 MHz ~ 5320 MHz> 802.11a : 17.45 MHz 802.11n HT20 : 18.25 MHz 802.11n HT40 : 36.20 MHz 802.11ac VHT80 : 75.36 MHz <5500 MHz ~ 5720 MHz> 802.11a : 17.20 MHz 802.11n HT20 : 18.25 MHz 802.11n HT40 : 36.30 MHz 802.11ac VHT80 : 75.12 MHz
Antenna Type / Gain	<5260 MHz ~ 5320 MHz> Fixed Internal Antenna with gain 1.30 dBi <5500 MHz ~ 5720 MHz > Fixed Internal Antenna with gain 1.90 dBi
Type of Modulation	802.11a/n : OFDM (BPSK / QPSK / 16QAM / 64QAM) 802.11ac : OFDM (BPSK / QPSK / 16QAM / 64QAM / 256QAM)

1.4 Modification of EUT

No modifications are made to the EUT during all test items.



1.5 Testing Location

Sporton Lab is accredited to ISO 17025 by Taiwan Accreditation Foundation (TAF code : 1190) and the FCC designation No. TW1190 and TW0007 under the FCC 2.948(e) by Mutual Recognition Agreement (MRA) in FCC Test.

Test Site	SPORTON INTERNATIONAL INC.
Test Site Location	No. 52, Hwa Ya 1 st Rd., Hwa Ya Technology Park, Kwei-Shan District, Tao Yuan City, Taiwan, R.O.C. TEL: +886-3-327-3456 FAX: +886-3-328-4978
Test Site No.	Sporton Site No.
	TH05-HY

Note: The test site complies with ANSI C63.4 2014 requirement.

Test Site	SPORTON INTERNATIONAL INC.
Test Site Location	No.58, Aly. 75, Ln. 564, Wenhua 3rd Rd. Guishan Dist, Taoyuan City, Taiwan (R.O.C.) TEL: +886-3-327-0868 FAX: +886-3-327-0855
Test Site No.	Sporton Site No.
	03CH13-HY

Note: The test site complies with ANSI C63.4 2014 requirement.

1.6 Applicable Standards

According to the specifications of the manufacturer, the EUT must comply with the requirements of the following standards:

- ♦ FCC Part 15 Subpart E
- ♦ FCC KDB 789033 D02 General UNII Test Procedures New Rules v02r01.
- ♦ ANSI C63.10-2013

Remark: All test items were verified and recorded according to the standards and without any deviation during the test.



2 Test Configuration of Equipment Under Test

- a. The EUT has been associated with peripherals and configuration operated in a manner tended to maximize its emission characteristics in a typical application. Frequency range investigated: radiation emission (9 kHz to the 10th harmonic of the highest fundamental frequency or to 40 GHz, whichever is lower). For radiated measurement, pre-scanned in three orthogonal panels, X, Y, Z. The worst cases (Z plane) were recorded in this report.

2.1 Carrier Frequency and Channel

Frequency Band	Channel	Freq. (MHz)	Channel	Freq. (MHz)
5250-5350 MHz Band 2 (U-NII-2A)	52	5260	60	5300
	54*	5270	62*	5310
	56	5280	64	5320
	58 [#]	5290		

Frequency Band	Channel	Freq. (MHz)	Channel	Freq. (MHz)
5470-5725 MHz Band 3 (U-NII-2C)	100	5500	112	5560
	102*	5510	116	5580
	104	5520	132	5660
	106 [#]	5530	134*	5670
	108	5540	136	5680
	110*	5550	140	5700

Frequency Band	Channel	Freq. (MHz)	Channel	Freq. (MHz)
TDWR Channel	118*	5590	124	5620
	120	5600	126*	5630
	122 [#]	5610	128	5640

Frequency Band	Channel	Freq. (MHz)	Channel	Freq. (MHz)
Straddle Channel	138 [#]	5690	144	5720
	142*	5710		

Note:

1. The above Frequency and Channel in "*" were 802.11n HT40 and 802.11ac VHT40.
2. The above Frequency and Channel in "[#]" were 802.11ac VHT80.



2.2 Test Mode

Final test modes are considering the modulation and worse data rates as below table.

Modulation	Data Rate
802.11a	6 Mbps
802.11n HT20	MCS0
802.11n HT40	MCS0
802.11ac VHT20 (Covered by HT20)	MCS0
802.11ac VHT40 (Covered by HT40)	MCS0
802.11ac VHT80	MCS0

Ch. #		Band II : 5250-5350 MHz	Band III : 5470-5725MHz
		802.11a	802.11a
L	Low	52	100
M	Middle	60	116
H	High	64	140
Straddle		-	144

Ch. #		Band II : 5250-5350 MHz	Band III : 5470-5725MHz
		802.11n HT20	802.11n HT20
L	Low	52	100
M	Middle	60	116
H	High	64	140
Straddle		-	144

Ch. #		Band II : 5250-5350 MHz	Band III : 5470-5725MHz
		802.11n HT40	802.11n HT40
L	Low	54	102
M	Middle	-	110
H	High	62	134
Straddle		-	142

Ch. #		Band II : 5250-5350 MHz	Band III : 5470-5725MHz
		802.11ac VHT80	802.11ac VHT80
L	Low	-	106
M	Middle	58	122
H	High	-	-
Straddle		-	138

2.3 Connection Diagram of Test System

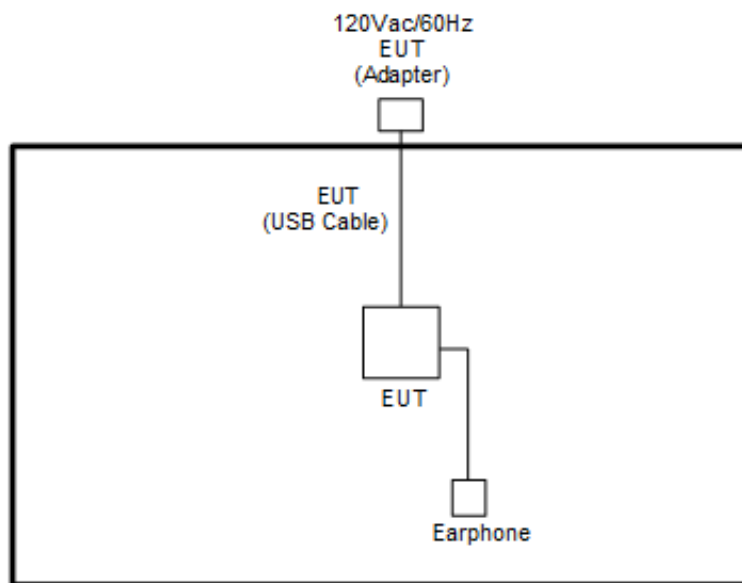

2.4 EUT Operation Test Setup

The RF test items, utility “CMD” was installed in Notebook which was programmed in order to make the EUT get into the engineering modes to provide channel selection, power level, data rate and the application type and for continuous transmitting signals.



2.5 Measurement Results Explanation Example

For all conducted test items:

The offset level is set in the spectrum analyzer to compensate the RF cable loss and attenuator factor between EUT conducted output port and spectrum analyzer. With the offset compensation, the spectrum analyzer reading level is exactly the EUT RF output level.

Example :

The spectrum analyzer offset is derived from RF cable loss and attenuator factor.

Offset = RF cable loss + attenuator factor.

Following shows an offset computation example with cable loss 4.2 dB and 10dB attenuator.

$$\begin{aligned} \text{Offset(dB)} &= \text{RF cable loss(dB)} + \text{attenuator factor(dB)}. \\ &= 4.2 + 10 = 14.2 \text{ (dB)} \end{aligned}$$

3 Test Result

3.1 26dB & 99% Occupied Bandwidth Measurement

3.1.1 Description of 26dB & 99% Occupied Bandwidth

This section is for reporting purpose only.

There is no restriction limits for bandwidth.

For Straddle Channel, According to KDB 789033 D02 General UNII Test Procedures New Rules v02r01, If the power and PSD of the devices are uniform and comply with the lower limits specified for the U-NII-2 bands, a single measurement over the entire emission bandwidth can be performed to show compliance.

3.1.2 Measuring Instruments

The measuring equipment is listed in the section 4 of this test report.

3.1.3 Test Procedures

1. The testing follows FCC KDB 789033 D02 General UNII Test Procedures New Rules v02r01. Section C) Emission bandwidth
2. Set RBW = approximately 1% of the emission bandwidth.
3. Set the VBW > RBW.
4. Detector = Peak.
5. Trace mode = max hold
6. Measure the maximum width of the emission that is 26 dB down from the peak of the emission. Compare this with the RBW setting of the analyzer. Readjust RBW and repeat measurement as needed until the RBW/EBW ratio is approximately 1%.
7. For 99% Bandwidth Measurement, the spectrum analyzer's resolution bandwidth (RBW) is set 1MHz and set the Video bandwidth (VBW) $\geq 3 * RBW$.
8. Measure and record the results in the test report.

3.1.4 Test Setup

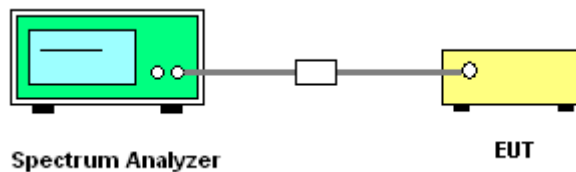



3.1.5 Test Result of 26dB & 99% Occupied Bandwidth

Please refer to Appendix A.

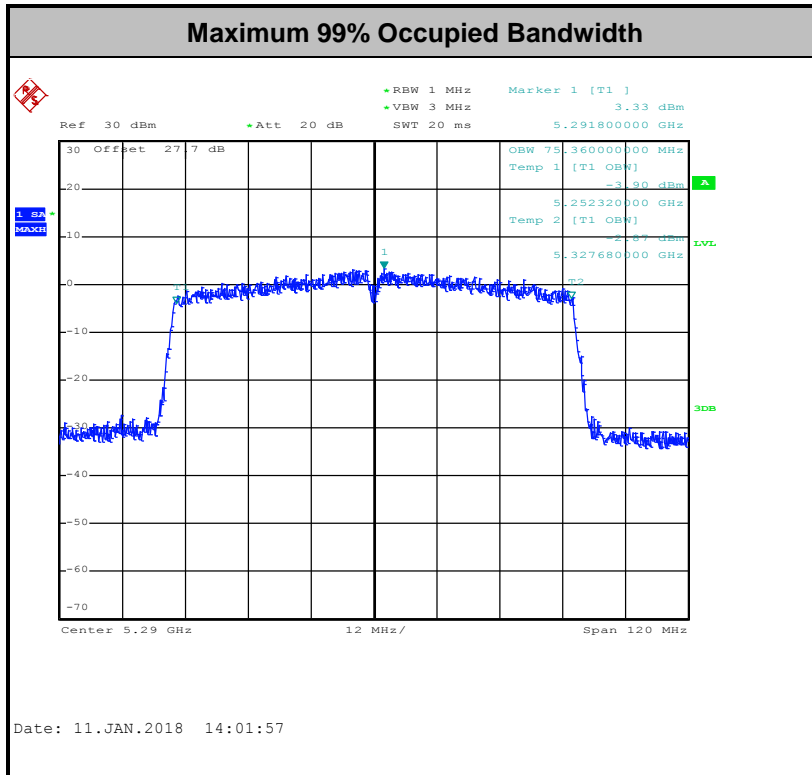
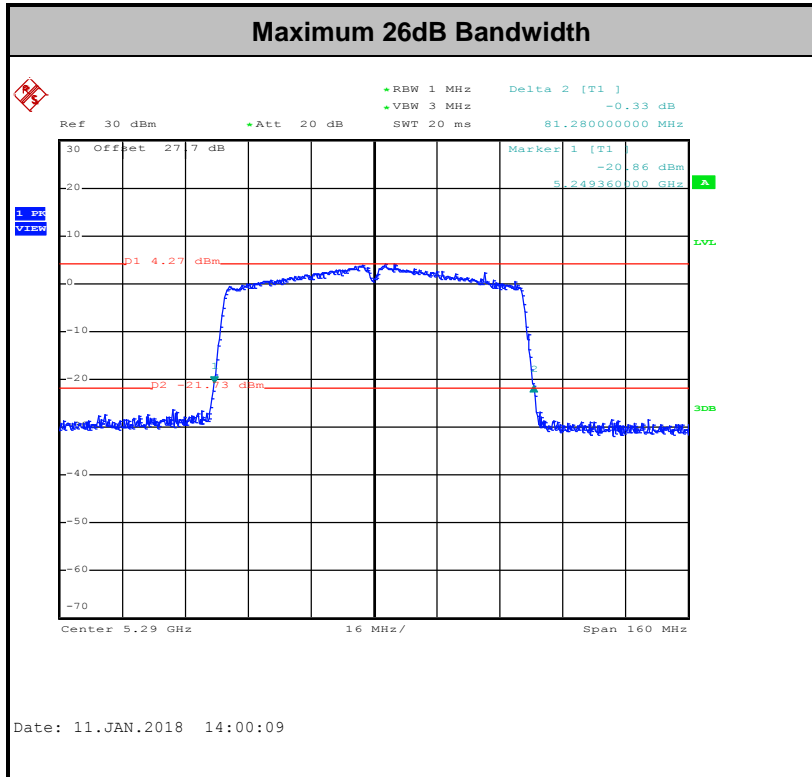

Note: The occupied channel bandwidth is maintained within the band of operation for all of the modulations.



3.2 Maximum Conducted Output Power Measurement

3.2.1 Limit of Maximum Conducted Output Power

<FCC 14-30 CFR 15.407>

For the 5.25–5.725 GHz bands, the maximum conducted output power over the frequency bands of operation shall not exceed the lesser of 250 mW or $11 \text{ dBm} + 10 \log B$, where B is the 26 dB emission bandwidth in megahertz.

For Straddle Channel, According to KDB 789033 D02 General UNII Test Procedures New Rules v02r01, If the power and PSD of the devices are uniform and comply with the lower limits specified for the U-NII-2 bands, a single measurement over the entire emission bandwidth can be performed to show compliance.

If transmitting antennas of directional gain greater than 6 dBi are used, the peak output power shall be reduced by the amount in dB that the directional gain of the antenna exceeds 6 dBi.

Note that U-NII-2 band, devices with a maximum e.i.r.p. greater than 500 mW shall implement TPC in order to have the capability to operate at least 6 dB below the maximum permitted e.i.r.p. of 1 W.

3.2.2 Measuring Instruments

The measuring equipment is listed in the section 4 of this test report.

3.2.3 Test Procedures

The testing follows Method PM of FCC KDB 789033 D02 General UNII Test Procedures New Rules v02r01.

Method PM (Measurement using an RF average power meter):

1. Measurement is performed using a wideband RF power meter.
2. The EUT is configured to transmit continuously with a consistent duty cycle at its maximum power control level.
3. Measure the average power of the transmitter, and the average power is corrected with duty factor, $10 \log(1/x)$, where x is the duty cycle.

For Straddle Channel, According to KDB 789033 D02 General UNII Test Procedures New Rules v02r01, If the power and PSD of the devices are uniform and comply with the lower limits specified for the U-NII-2 bands, a single measurement over the entire emission bandwidth can be performed to show compliance.

3.2.4 Test Setup

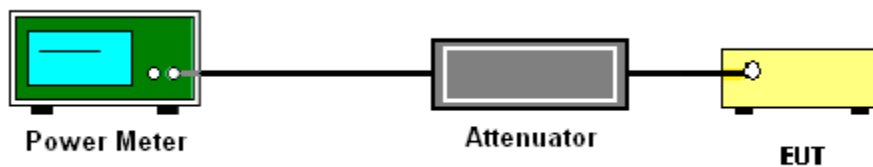

3.2.5 Test Result of Maximum Conducted Output Power

Please refer to Appendix A.



3.3 Power Spectral Density Measurement

3.3.1 Limit of Power Spectral Density

<FCC 14-30 CFR 15.407>

For the 5.25–5.725 GHz bands, the maximum power spectral density shall not exceed 11 dBm in any 1 megahertz band.

For Straddle Channel, According to KDB 789033 D02 General UNII Test Procedures New Rules v02r01, If the power and PSD of the devices are uniform and comply with the lower limits specified for the U-NII-2 bands, a single measurement over the entire emission bandwidth can be performed to show compliance.

If transmitting antennas of directional gain greater than 6 dBi are used, the peak output power shall be reduced by the amount in dB that the directional gain of the antenna exceeds 6 dBi.

3.3.2 Measuring Instruments

The measuring equipment is listed in the section 4 of this test report.

3.3.3 Test Procedures

The testing follows FCC KDB 789033 D02 General UNII Test Procedures New Rules v02r01. Section F) Maximum power spectral density.

Method SA-2

(trace averaging across on and off times of the EUT transmissions, followed by duty cycle correction).

- Measure the duty cycle.
- Set span to encompass the entire emission bandwidth (EBW) of the signal.
- Set RBW = 1 MHz.
- Set VBW \geq 3 MHz.
- Number of points in sweep \geq 2 Span / RBW.
- Sweep time = auto.
- Detector = RMS
- Trace average at least 100 traces in power averaging mode.
- Add $10 \log(1/x)$, where x is the duty cycle, to the measured power in order to compute the average power during the actual transmission times. For example, add $10 \log(1/0.25) = 6$ dB if the duty cycle is 25 percent.



3.4 Unwanted Emissions Measurement

This section is to measure unwanted emissions through radiated measurement for band edge spurious emissions and out of band emissions measurement.

3.4.1 Limit of Unwanted Emissions

For transmitters operating in the 5250-5350 MHz band: all emissions outside of the 5150-5350 MHz band shall not exceed an EIRP of -27 dBm/MHz. Devices operating in the 5250-5350 MHz band that generate emissions in the 5150-5250 MHz band must meet all applicable technical requirements for operation in the 5150-5250 MHz band (including indoor use) or alternatively meet an out-of-band emission EIRP limit of -27 dBm/MHz in the 5150-5250 MHz band.

For transmitters operating in the 5470-5600 MHz and 5650-5725MHz band: all emissions outside of the 5470-5600 MHz and 5650-5725MHz band shall not exceed an EIRP of -27 dBm/MHz.

(1) Unwanted spurious emissions fallen in restricted bands shall comply with the general field strength limits as below table,

Frequency (MHz)	Field Strength (microvolts/meter)	Measurement Distance (meters)
0.009 – 0.490	2400/F(kHz)	300
0.490 – 1.705	24000/F(kHz)	30
1.705 – 30.0	30	30
30 – 88	100	3
88 – 216	150	3
216 - 960	200	3
Above 960	500	3

Note: The following formula is used to convert the EIRP to field strength.

$$E = \frac{1000000\sqrt{30P}}{3} \text{ } \mu\text{V/m, where P is the eirp (Watts)}$$



EIRP (dBm)	Field Strength at 3m (dBµV/m)
-17	78.3
- 27	68.3

(2) KDB789033 D02 v02r01 G)2)c)

- (i) Section 15.407(b)(1) to (b)(3) specify the unwanted emission limits for the U-NII-1 and U-NII-2 bands. As specified, emissions above 1000 MHz that are outside of the restricted bands are subject to a peak emission limit of -27 dBm/MHz.³
- (ii) Section 15.407(b)(4) specifies the unwanted emission limit for the U-NII-3 band. A band emissions mask is specified in Section 15.407(b)(4)(i). The emission limits are in terms of a Peak detector. An alternative to the band emissions mask is specified in Section 15.407(b)(4)(ii). The alternative limits are based on the highest antenna gain specified in the filing. There are also marketing and importation restrictions for the devices using the alternative limit.⁴

Note 3: An out-of-band emission that complies with both the average and peak limits of Section 15.209 is not required to satisfy the -27 dBm/MHz peak emission limit.

Note 4: Only devices with antenna gains of 10 dBi or less may be approved using the emission limits specified in Section 15.247(d) till March 2, 2018; all other devices operating in this band must use the mask specified in Section 15.407(b)(4)(i).

3.4.2 Measuring Instruments

The measuring equipment is listed in the section 4 of this test report.



3.4.3 Test Procedures

1. The testing follows FCC KDB 789033 D02 General UNII Test Procedures New Rules v02r01. Section G) Unwanted emissions measurement.
 - (1) Procedure for Unwanted Emissions Measurements Below 1000MHz
 - RBW = 120 kHz
 - VBW = 300 kHz
 - Detector = Peak
 - Trace mode = max hold
 - (2) Procedure for Peak Unwanted Emissions Measurements Above 1000 MHz
 - RBW = 1 MHz
 - VBW \geq 3 MHz
 - Detector = Peak
 - Sweep time = auto
 - Trace mode = max hold
 - (3) Procedures for Average Unwanted Emissions Measurements Above 1000MHz
 - RBW = 1 MHz
 - VBW = 10 Hz, when duty cycle is no less than 98 percent.
 - VBW \geq 1/T, when duty cycle is less than 98 percent where T is the minimum transmission duration over which the transmitter is on and is transmitting at its maximum power control level for the tested mode of operation.
2. The EUT was placed on a turntable with 0.8 meter for frequency below 1GHz and 1.5 meter for frequency above 1GHz respectively above ground.
3. The EUT was set 3 meters from the interference receiving antenna which was mounted on the top of a variable height antenna tower.
4. The antenna is a broadband antenna and its height is adjusted between one meter and four meters above ground to find the maximum value of the field strength for both horizontal polarization and vertical polarization of the antenna.
5. For each suspected emission, the EUT was arranged to its worst case and then adjust the antenna tower (from 1 m to 4 m) and turntable (from 0 degree to 360 degrees) to find the maximum reading.
6. For testing below 1GHz, if the emission level of the EUT in peak mode was 3 dB lower than the limit specified, then peak values of EUT will be reported, otherwise, the emissions will be repeated one by one using the CISPR quasi-peak method and reported.

- 7. For testing above 1GHz, the emission level of the EUT in peak mode was 20dB lower than average limit (that means the emission level in average mode also complies with the limit in average mode), then peak values of EUT will be reported, otherwise, the emissions will be measured in average mode again and reported.

3.4.4 Test Setup

For radiated emissions below 30MHz

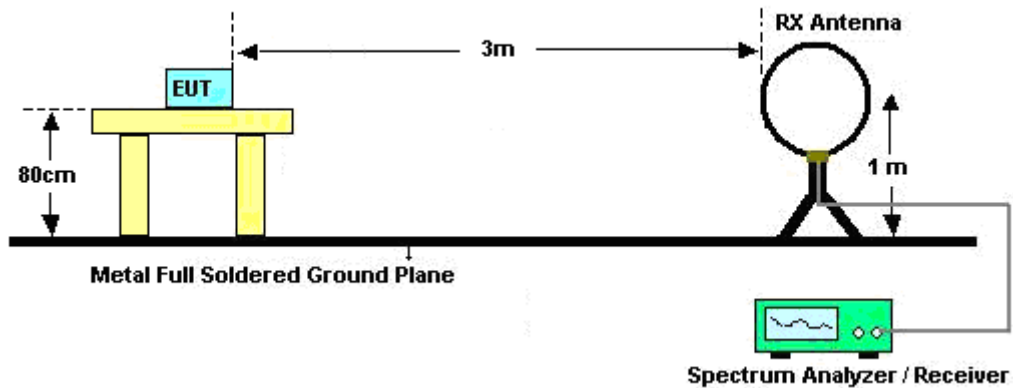

For radiated emissions from 30MHz to 1GHz

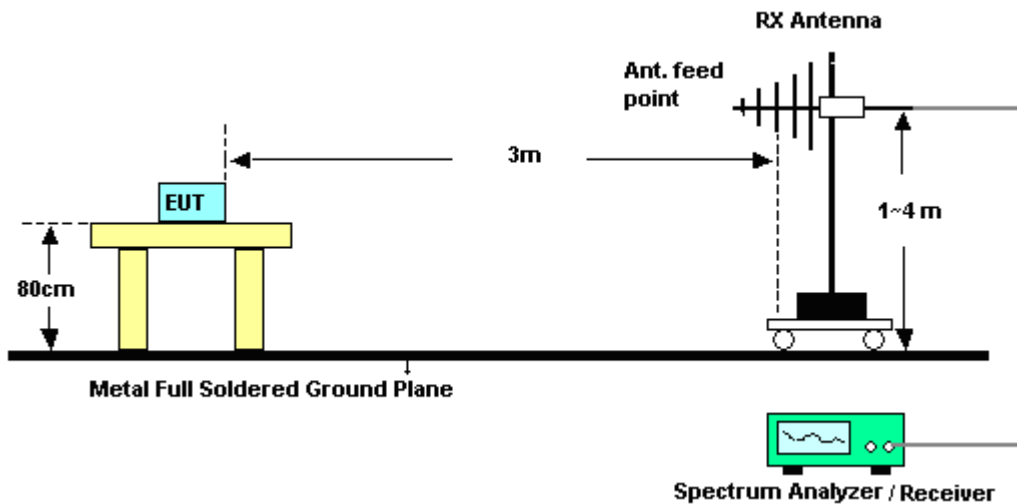

For radiated emissions above 1GHz

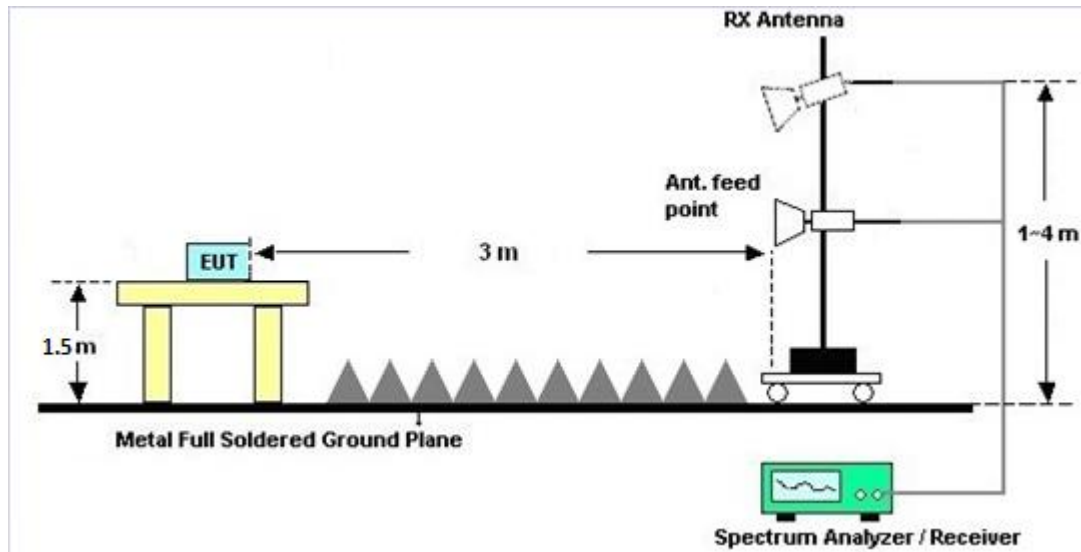

3.4.5 Test Results of Radiated Spurious Emissions (9 kHz ~ 30 MHz)

The low frequency, which started from 9 kHz to 30MHz, was pre-scanned and the result which was 20dB lower than the limit line was not reported.

There is a comparison data of both open-field test site and semi-Anechoic chamber, and the result came out very similar.

3.4.6 Test Result of Radiated Spurious at Band Edges

Please refer to Appendix B and C.

3.4.7 Duty Cycle

Please refer to Appendix D.

3.4.8 Test Result of Radiated Spurious Emissions (30MHz ~ 10th Harmonic)

Please refer to Appendix B and C.



3.5 Automatically Discontinue Transmission

3.5.1 Limit of Automatically Discontinue Transmission

The device shall automatically discontinue transmission in case of either absence of information to transmit or operational failure. These provisions are not intended to preclude the transmission of control or signaling information or the use of repetitive codes used by certain digital technologies to complete frame or burst intervals. Applicants shall include in their application for equipment authorization to describe how this requirement is met.

3.5.2 Measuring Instruments

The measuring equipment is listed in the section 4 of this test report.

3.5.3 Test Result of Automatically Discontinue Transmission

While the EUT is not transmitting any information, the EUT can automatically discontinue transmission and become standby mode for power saving. The EUT can detect the controlling signal of ACK message transmitting from remote device and verify whether it shall resend or discontinue transmission.



3.6 Antenna Requirements

3.6.1 Standard Applicable

If transmitting antenna directional gain is greater than 6 dBi, both the peak transmit power and the peak power spectral density shall be reduced by the amount in dB that the directional gain of the antenna exceeds 6 dBi.

3.6.2 Antenna Anti-Replacement Construction

An embedded-in antenna design is used.

3.6.3 Antenna Gain

The antenna peak gain of EUT is less than 6 dBi. Therefore, it is not necessary to reduce maximum peak output power limit.



4 List of Measuring Equipment

Instrument	Manufacturer	Model No.	Serial No.	Characteristics	Calibration Date	Test Date	Due Date	Remark
Power Meter	Anritsu	ML2495A	0932001	N/A	Sep. 26, 2017	Dec. 20, 2017~ Jan. 11, 2018	Sep. 25, 2018	Conducted (TH05-HY)
Power Sensor	Anritsu	MA2411B	0846202	300MHz~40GHz	Sep. 26, 2017	Dec. 20, 2017~ Jan. 11, 2018	Sep. 25, 2018	Conducted (TH05-HY)
Spectrum Analyzer	Rohde & Schwarz	FSP30	101067	9kHz ~ 30GHz	Nov. 13, 2017	Dec. 20, 2017~ Jan. 11, 2018	Nov. 12, 2018	Conducted (TH05-HY)
Loop Antenna	Rohde & Schwarz	HFH2-Z2	100315	9 kHz~30 MHz	Nov. 10, 2017	Dec. 22, 2017 ~ Jan. 15, 2018	Nov. 09, 2019	Radiation (03CH13-HY)
Amplifier	MITEQ	TTA1840-3 5-HG	1871923	18GHz~40GHz, VSWR : 2.5:1 max	Jul. 18, 2017	Dec. 22, 2017 ~ Jan. 15, 2018	Jul. 17, 2018	Radiation (03CH13-HY)
Amplifier	Sonoma-Instrument	310 N	187282	9KHz~1GHz	Dec. 21, 2016	Dec. 22, 2017 ~ Jan. 15, 2018	Dec. 20, 2018	Radiation (03CH13-HY)
Bilog Antenna	TESEQ	CBL 6111D&N-6 -06	35414&AT- N0602	30MHz~1GHz	Oct. 14, 2017	Dec. 22, 2017 ~ Jan. 15, 2018	Oct. 13, 2018	Radiation (03CH13-HY)
Horn Antenna	SCHWARZBECK	BBHA 9120 D	9120D-124 1	1GHz ~ 18GHz	Jun. 15, 2017	Dec. 22, 2017 ~ Jan. 15, 2018	Jun. 14, 2018	Radiation (03CH13-HY)
Preamplifier	MITEQ	AMF-7D-00 101800-30- 10P	1590074	1GHz~18GHz	May 22, 2017	Dec. 22, 2017 ~ Jan. 15, 2018	May 21, 2018	Radiation (03CH13-HY)
Preamplifier	Keysight	83017A	MY532702 64	1GHz ~ 26.5GHz	Dec. 05, 2017	Dec. 22, 2017 ~ Jan. 15, 2018	Dec. 04, 2018	Radiation (03CH13-HY)
Spectrum Analyzer	Keysight	N9010A	MY553705 26	N/A	Mar. 15, 2017	Dec. 22, 2017 ~ Jan. 15, 2018	Mar. 14, 2018	Radiation (03CH13-HY)
Antenna Mast	EMEC	AM-BS-450 0-B	N/A	1m~4m	N/A	Dec. 22, 2017 ~ Jan. 15, 2018	N/A	Radiation (03CH13-HY)
Turn Table	EMEC	TT2000	N/A	0~360 Degree	N/A	Dec. 22, 2017 ~ Jan. 15, 2018	N/A	Radiation (03CH13-HY)
SHF-EHF Horn Antenna	SCHWARZBECK	BBHA 9170	BBHA9170 584	18GHz- 40GHz	Nov. 27, 2017	Dec. 22, 2017 ~ Jan. 15, 2018	Nov. 26, 2018	Radiation (03CH13-HY)
EMI Test Receiver	Agilent	N9038A (MXE)	MY554201 70	20Hz to 26.5GHz	Mar. 03, 2017	Dec. 22, 2017 ~ Jan. 15, 2018	Mar. 02, 2017	Radiation (03CH13-HY)



5 Uncertainty of Evaluation

Uncertainty of Radiated Emission Measurement (30 MHz ~ 1000 MHz)

Measuring Uncertainty for a Level of Confidence of 95% ($U = 2Uc(y)$)	4.9
---	-----

Uncertainty of Radiated Emission Measurement (1000 MHz ~ 18000 MHz)

Measuring Uncertainty for a Level of Confidence of 95% ($U = 2Uc(y)$)	5.4
---	-----

Uncertainty of Radiated Emission Measurement (18000 MHz ~ 40000 MHz)

Measuring Uncertainty for a Level of Confidence of 95% ($U = 2Uc(y)$)	4.3
---	-----

Appendix A. Test Result of Conducted Test Items

Test Engineer:	Shiming Liu/Reece Lin	Temperature:	21~25	°C
Test Date:	2017/12/20~2018/1/11	Relative Humidity:	51~54	%

TEST RESULTS DATA
26dB and 99% OBW

Band II										
Mod.	Data Rate	NTX	CH.	Freq. (MHz)	99% Bandwidth (MHz)	26 dB Bandwidth (MHz)	IC 99% Bandwidth Power Limit (dBm)	IC 99% Bandwidth EIRP Limit (dBm)	FCC 26dB Bandwidth Power Limit (dBm)	Note
11a	6M bps	1	52	5260	17.45	21.20	23.42	29.42	23.98	
11a	6M bps	1	60	5300	17.05	21.60	23.32	29.32	23.98	
11a	6M bps	1	64	5320	17.15	21.30	23.34	29.34	23.98	
HT20	MCS 0	1	52	5260	18.05	21.55	23.56	29.56	23.98	
HT20	MCS 0	1	60	5300	18.10	21.50	23.58	29.58	23.98	
HT20	MCS 0	1	64	5320	18.25	21.85	23.61	29.61	23.98	
HT40	MCS 0	1	54	5270	36.10	41.40	23.98	30.00	23.98	
HT40	MCS 0	1	62	5310	36.20	41.40	23.98	30.00	23.98	
VHT80	MCS 0	1	58	5290	75.36	81.28	23.98	30.00	23.98	

TEST RESULTS DATA
Average Power Table

FCC Band II										
Mod.	Data Rate	NTX	CH.	Freq. (MHz)	Duty Factor (dB)	Average Conducted Power (dBm)	FCC Conducted Power Limit (dBm)	DG (dBi)	EIRP Power Limit (dBm)	Pass/Fail
11a	6M bps	1	52	5260	0.00	13.85	23.98	1.30	26.99	Pass
11a	6M bps	1	60	5300	0.00	13.90	23.98	1.30	26.99	Pass
11a	6M bps	1	64	5320	0.00	13.92	23.98	1.30	26.99	Pass
HT20	MCS 0	1	52	5260	0.00	13.75	23.98	1.30	26.99	Pass
HT20	MCS 0	1	60	5300	0.00	13.90	23.98	1.30	26.99	Pass
HT20	MCS 0	1	64	5320	0.00	13.92	23.98	1.30	26.99	Pass
HT40	MCS 0	1	54	5270	0.00	13.59	23.98	1.30	26.99	Pass
HT40	MCS 0	1	62	5310	0.00	13.95	23.98	1.30	26.99	Pass
VHT20	MCS 0	1	52	5260	0.00	12.80	23.98	1.30	26.99	Pass
VHT20	MCS 0	1	60	5300	0.00	12.92	23.98	1.30	26.99	Pass
VHT20	MCS 0	1	64	5320	0.00	12.98	23.98	1.30	26.99	Pass
VHT40	MCS 0	1	54	5270	0.00	12.77	23.98	1.30	26.99	Pass
VHT40	MCS 0	1	62	5310	0.00	12.96	23.98	1.30	26.99	Pass
VHT80	MCS 0	1	58	5290	0.00	12.95	23.98	1.30	26.99	Pass

TEST RESULTS DATA
Power Spectral Density

Band II										
Mod.	Data Rate	NTX	CH.	Freq. (MHz)	Duty Factor (dB)	Average Power Density (dBm/MHz)	Average PSD Limit (dBm/MHz)	DG (dBi)		Pass/Fail
11a	6M bps	1	52	5260	0.00	3.12	11.00	1.30		Pass
11a	6M bps	1	60	5300	0.00	3.42	11.00	1.30		Pass
11a	6M bps	1	64	5320	0.00	3.28	11.00	1.30		Pass
HT20	MCS 0	1	52	5260	0.00	2.70	11.00	1.30		Pass
HT20	MCS 0	1	60	5300	0.00	2.94	11.00	1.30		Pass
HT20	MCS 0	1	64	5320	0.00	2.92	11.00	1.30		Pass
HT40	MCS 0	1	54	5270	0.00	-0.26	11.00	1.30		Pass
HT40	MCS 0	1	62	5310	0.00	0.05	11.00	1.30		Pass
VHT80	MCS 0	1	58	5290	0.00	-4.86	11.00	1.30		Pass

TEST RESULTS DATA
26dB and 99% OBW

Band III										
Mod.	Data Rate	NTX	CH.	Freq. (MHz)	99% Bandwidth In UNII-2C (MHz)	26 dB Bandwidth In UNII-2C (MHz)	IC 99% Bandwidth Power Limit (dBm)	IC 99% Bandwidth EIRP Limit (dBm)	FCC 26dB Bandwidth Power Limit (dBm)	6dB Bandwidth for Straddle Channel (MHz)
11a	6M bps	1	100	5500	17.20	21.40	23.36	29.36	23.98	----
11a	6M bps	1	116	5580	17.05	21.10	23.32	29.32	23.98	----
11a	6M bps	1	140	5700	17.20	21.20	23.36	29.36	23.98	----
11a	6Mbps	1	144	5720	13.70	15.65	22.37	28.37	22.95	3.14
HT20	MCS 0	1	100	5500	18.10	21.75	23.58	29.58	23.98	----
HT20	MCS 0	1	116	5580	18.15	21.75	23.59	29.59	23.98	----
HT20	MCS 0	1	140	5700	18.25	21.85	23.61	29.61	23.98	----
HT20	MCS0	1	144	5720	14.05	15.90	22.48	28.48	23.01	3.76
HT40	MCS 0	1	102	5510	36.20	41.52	23.98	30.00	23.98	----
HT40	MCS 0	1	110	5550	36.10	41.40	23.98	30.00	23.98	----
HT40	MCS 0	1	134	5670	36.30	41.58	23.98	30.00	23.98	----
HT40	MCS0	1	142	5710	33.20	35.70	23.98	30.00	23.98	2.16
VHT80	MCS 0	1	106	5530	75.12	80.96	23.98	30.00	23.98	----
VHT80	MCS 0	1	122	5610	75.12	80.96	23.98	30.00	23.98	----
VHT80	MCS0	1	138	5690	72.80	75.64	23.98	30.00	23.98	3.24

TEST RESULTS DATA
Average Power Table

FCC Band III										
Mod.	Data Rate	NTX	CH.	Freq. (MHz)	Duty Factor (dB)	Average Conducted Power (dBm)	FCC Conducted Power Limit (dBm)	DG (dBi)	EIRP Power Limit (dBm)	Pass/Fail
11a	6M bps	1	100	5500	0.00	13.60	23.98	1.90	26.99	Pass
11a	6M bps	1	116	5580	0.00	13.58	23.98	1.90	26.99	Pass
11a	6M bps	1	140	5700	0.00	13.55	23.98	1.90	26.99	Pass
11a	6M bps	1	144	5720	0.00	13.51	22.95	1.90	26.99	Pass
HT20	MCS 0	1	100	5500	0.00	13.99	23.98	1.90	26.99	Pass
HT20	MCS 0	1	116	5580	0.00	13.60	23.98	1.90	26.99	Pass
HT20	MCS 0	1	140	5700	0.00	13.58	23.98	1.90	26.99	Pass
HT20	MCS 0	1	144	5720	0.00	13.52	23.01	1.90	26.99	Pass
HT40	MCS 0	1	102	5510	0.00	13.98	23.98	1.90	26.99	Pass
HT40	MCS 0	1	110	5550	0.00	13.73	23.98	1.90	26.99	Pass
HT40	MCS 0	1	134	5670	0.00	13.55	23.98	1.90	26.99	Pass
HT40	MCS 0	1	142	5710	0.00	13.51	23.98	1.90	26.99	Pass
VHT20	MCS 0	1	100	5500	0.00	12.99	23.98	1.90	26.99	Pass
VHT20	MCS 0	1	116	5580	0.00	12.96	23.98	1.90	26.99	Pass
VHT20	MCS 0	1	140	5700	0.00	12.55	23.98	1.90	26.99	Pass
VHT20	MCS 0	1	144	5720	0.00	12.54	23.98	1.90	26.99	Pass
VHT40	MCS 0	1	102	5510	0.00	12.98	23.98	1.90	26.99	Pass
VHT40	MCS 0	1	110	5550	0.00	12.60	23.98	1.90	26.99	Pass
VHT40	MCS 0	1	134	5670	0.00	12.52	23.98	1.90	26.99	Pass
VHT40	MCS 0	1	142	5710	0.00	12.51	23.98	1.90	26.99	Pass
VHT80	MCS 0	1	106	5530	0.00	12.56	23.98	1.90	26.99	Pass
VHT80	MCS 0	1	122	5610	0.00	12.51	23.98	1.90	26.99	Pass
VHT80	MCS 0	1	138	5690	0.00	12.78	23.98	1.90	26.99	Pass

TEST RESULTS DATA
Power Spectral Density

Band III										
Mod.	Data Rate	NTX	CH.	Freq. (MHz)	Duty Factor (dB)	Average Power Density (dBm/MHz)	Average PSD Limit (dBm/MHz)	DG (dBi)		Pass/Fail
11a	6M bps	1	100	5500	0.00	3.88	11.00	1.90		Pass
11a	6M bps	1	116	5580	0.00	3.77	11.00	1.90		Pass
11a	6M bps	1	140	5700	0.00	3.18	11.00	1.90		Pass
11a	6Mbps	1	144	5720	0.00	3.04	11.00	1.90		Pass
HT20	MCS 0	1	100	5500	0.00	3.55	11.00	1.90		Pass
HT20	MCS 0	1	116	5580	0.00	3.40	11.00	1.90		Pass
HT20	MCS 0	1	140	5700	0.00	3.21	11.00	1.90		Pass
HT20	MCS0	1	144	5720	0.00	2.73	11.00	1.90		Pass
HT40	MCS 0	1	102	5510	0.00	0.72	11.00	1.90		Pass
HT40	MCS 0	1	110	5550	0.00	1.03	11.00	1.90		Pass
HT40	MCS 0	1	134	5670	0.00	0.69	11.00	1.90		Pass
HT40	MCS0	1	142	5710	0.00	0.01	11.00	1.90		Pass
VHT80	MCS 0	1	106	5530	0.00	-4.26	11.00	1.90		Pass
VHT80	MCS 0	1	122	5610	0.00	-5.09	11.00	1.90		Pass
VHT80	MCS0	1	138	5690	0.00	-4.98	11.00	1.90		Pass



Appendix B. Radiated Spurious Emission

Test Engineer :	Alex Jheng, Bill Chang, and Wilson Wu	Temperature :	24.0~24.1°C
		Relative Humidity :	52~53%

Band 2 - 5250~5350MHz

WIFI 802.11a (Band Edge @ 3m)

WIFI	Note	Frequency	Level	Over	Limit	Read	Antenna	Cable	Preamp	Ant	Table	Peak	Pol.
Ant.				Limit	Line	Level	Factor	Loss	Factor	Pos	Pos	Avg.	
1		(MHz)	(dBμV/m)	(dB)	(dBμV/m)	(dBμV)	(dB/m)	(dB)	(dB)	(cm)	(deg)	(P/A)	(H/V)
802.11a CH 52 5260MHz		5082.62	51.16	-22.84	74	42.5	31.9	7.31	30.55	100	131	P	H
		5084.66	40.07	-13.93	54	31.41	31.9	7.31	30.55	100	131	A	H
	*	5260	103.63	-	-	94.68	32.12	7.41	30.58	100	131	P	H
	*	5260	96.41	-	-	87.46	32.12	7.41	30.58	100	131	A	H
		5397.84	48.82	-25.18	74	39.65	32.28	7.49	30.6	100	131	P	H
		5458.32	39.55	-14.45	54	30.27	32.34	7.54	30.6	100	131	A	H
		5139.06	50.86	-23.14	74	42.12	31.96	7.34	30.56	126	115	P	V
		5149.6	40.61	-13.39	54	31.84	31.98	7.35	30.56	126	115	A	V
	*	5260	107.67	-	-	98.72	32.12	7.41	30.58	126	115	P	V
	*	5260	101.25	-	-	92.3	32.12	7.41	30.58	126	115	A	V
		5380.32	50.3	-23.7	74	41.15	32.26	7.48	30.59	126	115	P	V
		5351.04	40.27	-13.73	54	31.18	32.22	7.46	30.59	126	115	A	V
802.11a CH 60 5300MHz		5079.56	50.84	-23.16	74	42.18	31.9	7.31	30.55	100	134	P	H
		5044.88	40.06	-13.94	54	31.46	31.86	7.29	30.55	100	134	A	H
	*	5300	102.81	-	-	93.8	32.16	7.43	30.58	100	134	P	H
	*	5300	95.44	-	-	86.43	32.16	7.43	30.58	100	134	A	H
		5454.72	49.69	-24.31	74	40.41	32.34	7.54	30.6	100	134	P	H
		5456.64	39.56	-14.44	54	30.28	32.34	7.54	30.6	100	134	A	H
		5147.22	51.86	-22.14	74	43.09	31.98	7.35	30.56	100	112	P	V
		5149.26	40.38	-13.62	54	31.61	31.98	7.35	30.56	100	112	A	V
	*	5300	107.17	-	-	98.16	32.16	7.43	30.58	100	112	P	V
	*	5300	99.85	-	-	90.84	32.16	7.43	30.58	100	112	A	V
		5363.52	50.55	-23.45	74	41.43	32.24	7.47	30.59	100	112	P	V
		5351.76	40.84	-13.16	54	31.75	32.22	7.46	30.59	100	112	A	V



802.11a CH 64 5320MHz	*	5320	103.1	-	-	94.07	32.18	7.44	30.59	100	132	P	H
	*	5320	95.45	-	-	86.42	32.18	7.44	30.59	100	132	A	H
		5422.88	51.52	-22.48	74	42.31	32.3	7.51	30.6	100	132	P	H
		5458.08	39.69	-14.31	54	30.41	32.34	7.54	30.6	100	132	A	H
	*	5320	106.66	-	-	97.63	32.18	7.44	30.59	100	105	P	V
	*	5320	99.24	-	-	90.21	32.18	7.44	30.59	100	105	A	V
		5407.04	49.73	-24.27	74	40.56	32.28	7.49	30.6	100	105	P	V
		5350.24	40.9	-13.1	54	31.81	32.22	7.46	30.59	100	105	A	V
Remark	<ol style="list-style-type: none"> No other spurious found. All results are PASS against Peak and Average limit line. 												



**Band 2 5250~5350MHz
WIFI 802.11a (Harmonic @ 3m)**

WIFI Ant. 1	Note	Frequency (MHz)	Level (dBμV/m)	Over Limit (dB)	Limit Line (dBμV/m)	Read Level (dBμV)	Antenna Factor (dB/m)	Cable Loss (dB)	Preamp Factor (dB)	Ant Pos (cm)	Table Pos (deg)	Peak Avg. (P/A)	Pol. (H/V)
802.11a CH 52 5260MHz		10520	48.04	-20.16	68.2	54.11	39.52	10.86	56.99	100	0	P	H
		15780	45.54	-28.46	74	50.32	37.68	13.13	56.33	100	0	P	H
		10520	47.05	-21.15	68.2	53.12	39.52	10.86	56.99	100	0	P	V
		15780	45.3	-28.7	74	50.08	37.68	13.13	56.33	100	0	P	V
802.11a CH 60 5300MHz		10600	46.65	-27.35	74	52.51	39.62	10.9	56.92	100	0	P	H
		15900	44.98	-29.02	74	49.94	37.37	13.2	56.26	100	0	P	H
		10600	46.52	-27.48	74	52.38	39.62	10.9	56.92	100	0	P	V
		15900	44.55	-29.45	74	49.51	37.37	13.2	56.26	100	0	P	V
802.11a CH 64 5320MHz		10640	47.83	-26.17	74	53.59	39.67	10.93	56.89	100	0	P	H
		15960	45.45	-28.55	74	50.53	37.19	13.23	56.22	100	0	P	H
		10640	46.93	-27.07	74	52.69	39.67	10.93	56.89	100	0	P	V
		15960	44.93	-29.07	74	50.01	37.19	13.23	56.22	100	0	P	V
Remark	1. No other spurious found. 2. All results are PASS against Peak and Average limit line.												



**Band 2 5250~5350MHz
WIFI 802.11n HT20 (Band Edge @ 3m)**

WIFI Ant. 1	Note	Frequency (MHz)	Level (dBμV/m)	Over Limit (dB)	Limit Line (dBμV/m)	Read Level (dBμV)	Antenna Factor (dB/m)	Cable Loss (dB)	Preamp Factor (dB)	Ant Pos (cm)	Table Pos (deg)	Peak Avg. (P/A)	Pol. (H/V)
802.11n HT20 CH 52 5260MHz		5086.02	51.57	-22.43	74	42.91	31.9	7.31	30.55	207	281	P	H
		5135.32	40.17	-13.83	54	31.43	31.96	7.34	30.56	207	281	A	H
	*	5260	103.35	-	-	94.4	32.12	7.41	30.58	207	281	P	H
	*	5260	96.04	-	-	87.09	32.12	7.41	30.58	207	281	A	H
		5351.52	50.21	-23.79	74	41.12	32.22	7.46	30.59	207	281	P	H
		5459.52	39.59	-14.41	54	30.31	32.34	7.54	30.6	207	281	A	H
		5032.64	50.67	-23.33	74	42.09	31.84	7.28	30.54	222	108	P	V
		5148.92	40.96	-13.04	54	32.19	31.98	7.35	30.56	222	108	A	V
	*	5260	107.95	-	-	99	32.12	7.41	30.58	222	108	P	V
	*	5260	100.51	-	-	91.56	32.12	7.41	30.58	222	108	A	V
		5455.2	50.67	-23.33	74	41.39	32.34	7.54	30.6	222	108	P	V
		5350.08	40.5	-13.5	54	31.41	32.22	7.46	30.59	222	108	A	V
802.11n HT20 CH 60 5300MHz		5103.36	50.3	-23.7	74	41.61	31.92	7.32	30.55	219	284	P	H
		5082.62	40.03	-13.97	54	31.37	31.9	7.31	30.55	219	284	A	H
	*	5300	103.7	-	-	94.69	32.16	7.43	30.58	219	284	P	H
	*	5300	96.38	-	-	87.37	32.16	7.43	30.58	219	284	A	H
		5459.76	50.2	-23.8	74	40.92	32.34	7.54	30.6	219	284	P	H
		5352	39.7	-14.3	54	30.61	32.22	7.46	30.59	219	284	A	H
		5038.42	50.98	-23.02	74	42.38	31.86	7.29	30.55	231	106	P	V
		5149.26	40.48	-13.52	54	31.71	31.98	7.35	30.56	231	106	A	V
	*	5300	107.52	-	-	98.51	32.16	7.43	30.58	231	106	P	V
	*	5300	100.3	-	-	91.29	32.16	7.43	30.58	231	106	A	V
	5424	50.74	-23.26	74	41.53	32.3	7.51	30.6	231	106	P	V	
	5350.8	40.74	-13.26	54	31.65	32.22	7.46	30.59	231	106	A	V	



802.11n HT20 CH 64 5320MHz	*	5320	103.51	-	-	94.48	32.18	7.44	30.59	203	283	P	H
	*	5320	96.08	-	-	87.05	32.18	7.44	30.59	203	283	A	H
		5350.24	50.03	-23.97	74	40.94	32.22	7.46	30.59	203	283	P	H
		5350.08	39.79	-14.21	54	30.7	32.22	7.46	30.59	203	283	A	H
	*	5320	107.32	-	-	98.29	32.18	7.44	30.59	225	106	P	V
	*	5320	100.04	-	-	91.01	32.18	7.44	30.59	225	106	A	V
		5444.8	50.66	-23.34	74	41.42	32.32	7.52	30.6	225	106	P	V
		5350.08	41.24	-12.76	54	32.15	32.22	7.46	30.59	225	106	A	V
Remark	1. No other spurious found. 2. All results are PASS against Peak and Average limit line.												



Band 2 5250~5350MHz
WIFI 802.11n HT20 (Harmonic @ 3m)

WIFI Ant. 1	Note	Frequency (MHz)	Level (dBμV/m)	Over Limit (dB)	Limit Line (dBμV/m)	Read Level (dBμV)	Antenna Factor (dB/m)	Cable Loss (dB)	Preamp Factor (dB)	Ant Pos (cm)	Table Pos (deg)	Peak Avg. (P/A)	Pol. (H/V)
802.11n HT20 CH 52		10520	47.01	-21.19	68.2	53.08	39.52	10.86	56.99	100	0	P	H
		15780	44.81	-29.19	74	49.59	37.68	13.13	56.33	100	0	P	H
5260MHz		10520	47.23	-20.97	68.2	53.3	39.52	10.86	56.99	100	0	P	V
		15780	44.76	-29.24	74	49.54	37.68	13.13	56.33	100	0	P	V
802.11n HT20 CH 60		10600	46.24	-27.76	74	52.1	39.62	10.9	56.92	100	0	P	H
		15900	45.11	-28.89	74	50.07	37.37	13.2	56.26	100	0	P	H
		10600	45.78	-28.22	74	51.64	39.62	10.9	56.92	100	0	P	V
		15900	44.72	-29.28	74	49.68	37.37	13.2	56.26	100	0	P	V
802.11n HT20 CH 64		10640	46.86	-27.14	74	52.62	39.67	10.93	56.89	100	0	P	H
		15960	45.62	-28.38	74	50.7	37.19	13.23	56.22	100	0	P	H
		10640	46.41	-27.59	74	52.17	39.67	10.93	56.89	100	0	P	V
		15960	44.53	-29.47	74	49.61	37.19	13.23	56.22	100	0	P	V
Remark	1. No other spurious found. 2. All results are PASS against Peak and Average limit line.												



**Band 2 5250~5350MHz
WIFI 802.11n HT40 (Band Edge @ 3m)**

WIFI Ant. 1	Note	Frequency (MHz)	Level (dBμV/m)	Over Limit (dB)	Limit Line (dBμV/m)	Read Level (dBμV)	Antenna Factor (dB/m)	Cable Loss (dB)	Preamp Factor (dB)	Ant Pos (cm)	Table Pos (deg)	Peak Avg. (P/A)	Pol. (H/V)	
802.11n HT40 CH 54 5270MHz		5119.68	50.08	-23.92	74	41.37	31.94	7.33	30.56	207	282	P	H	
		5113.22	39.97	-14.03	54	31.26	31.94	7.33	30.56	207	282	A	H	
	*	5270	100.9	-	-	91.94	32.12	7.42	30.58	207	282	P	H	
	*	5270	93.43	-	-	84.47	32.12	7.42	30.58	207	282	A	H	
		5433.84	50.02	-23.98	74	40.78	32.32	7.52	30.6	207	282	P	H	
		5457.12	39.53	-14.47	54	30.25	32.34	7.54	30.6	207	282	A	H	
		5123.42	51.78	-22.22	74	43.05	31.96	7.33	30.56	216	106	P	V	
		5149.94	40.58	-13.42	54	31.81	31.98	7.35	30.56	216	106	A	V	
	*	5270	104.68	-	-	95.72	32.12	7.42	30.58	216	106	P	V	
	*	5270	97.26	-	-	88.3	32.12	7.42	30.58	216	106	A	V	
		5413.92	50.62	-23.38	74	41.41	32.3	7.51	30.6	216	106	P	V	
		5350.08	40.52	-13.48	54	31.43	32.22	7.46	30.59	216	106	A	V	
	802.11n HT40 CH 62 5310MHz		5052.02	50.75	-23.25	74	42.15	31.86	7.29	30.55	218	283	P	H
			5116.28	39.96	-14.04	54	31.25	31.94	7.33	30.56	218	283	A	H
*		5310	100.84	-	-	91.8	32.18	7.44	30.58	218	283	P	H	
*		5310	93.54	-	-	84.5	32.18	7.44	30.58	218	283	A	H	
		5351.76	53.32	-20.68	74	44.23	32.22	7.46	30.59	218	283	P	H	
		5350.08	42.57	-11.43	54	33.48	32.22	7.46	30.59	218	283	A	H	
		5126.14	51.17	-22.83	74	42.43	31.96	7.34	30.56	231	108	P	V	
		5149.6	40.43	-13.57	54	31.66	31.98	7.35	30.56	231	108	A	V	
*		5310	104.88	-	-	95.84	32.18	7.44	30.58	231	108	P	V	
*		5310	97.31	-	-	88.27	32.18	7.44	30.58	231	108	A	V	
	5350.8	54.41	-19.59	74	45.32	32.22	7.46	30.59	231	108	P	V		
	5350.08	44.9	-9.1	54	35.81	32.22	7.46	30.59	231	108	A	V		
Remark	1. No other spurious found. 2. All results are PASS against Peak and Average limit line.													



Band 2 5250~5350MHz
WIFI 802.11n HT40 (Harmonic @ 3m)

Table with 14 columns: WIFI Ant. 1, Note, Frequency (MHz), Level (dBµV/m), Over Limit (dB), Limit Line (dBµV/m), Read Level (dBµV), Antenna Factor (dB/m), Cable Loss (dB), Preamp Factor (dB), Ant Pos (cm), Table Pos (deg), Peak Avg. (P/A), Pol. (H/V). Rows include data for 802.11n, HT40, CH 54, 5270MHz, 802.11n, HT40, CH 62, 5310MHz, and a Remark section.



**Band 2 5250~5350MHz
WIFI 802.11ac VHT80 (Band Edge @ 3m)**

WIFI Ant. 1	Note	Frequency (MHz)	Level (dBμV/m)	Over Limit (dB)	Limit Line (dBμV/m)	Read Level (dBμV)	Antenna Factor (dB/m)	Cable Loss (dB)	Preamp Factor (dB)	Ant Pos (cm)	Table Pos (deg)	Peak Avg. (P/A)	Pol. (H/V)
802.11ac VHT80 CH 58 5290MHz		5138.38	50.71	-23.29	74	41.97	31.96	7.34	30.56	220	286	P	H
		5125.46	40.06	-13.94	54	31.32	31.96	7.34	30.56	220	286	A	H
	*	5290	96.68	-	-	87.69	32.14	7.43	30.58	220	286	P	H
	*	5290	88.9	-	-	79.91	32.14	7.43	30.58	220	286	A	H
		5350.56	50.98	-23.02	74	41.89	32.22	7.46	30.59	220	286	P	H
		5350.08	43.89	-10.11	54	34.8	32.22	7.46	30.59	220	286	A	H
		5088.06	50.43	-23.57	74	41.77	31.9	7.31	30.55	106	140	P	V
		5149.6	40.32	-13.68	54	31.55	31.98	7.35	30.56	106	140	A	V
	*	5290	99.66	-	-	90.67	32.14	7.43	30.58	106	140	P	V
	*	5290	91.8	-	-	82.81	32.14	7.43	30.58	106	140	A	V
		5356.32	56.79	-17.21	74	47.7	32.22	7.46	30.59	106	140	P	V
		5350.08	46.14	-7.86	54	37.05	32.22	7.46	30.59	106	140	A	V
Remark	1. No other spurious found. 2. All results are PASS against Peak and Average limit line.												



Band 2 5250~5350MHz
WIFI 802.11ac VHT80 (Harmonic @ 3m)

Table with 14 columns: WIFI Ant. 1, Note, Frequency (MHz), Level (dBµV/m), Over Limit (dB), Limit Line (dBµV/m), Read Level (dBµV), Antenna Factor (dB/m), Cable Loss (dB), Preamp Factor (dB), Ant Pos (cm), Table Pos (deg), Peak Avg. (P/A), Pol. (H/V). Rows include 802.11ac, VHT80, CH 58, 5290MHz and a Remark section.



Band 3 - 5470~5725MHz
WIFI 802.11a (Band Edge @ 3m)

WIFI	Note	Frequency	Level	Over	Limit	Read	Antenna	Cable	Preamp	Ant	Table	Peak	Pol.
Ant.				Limit	Line	Level	Factor	Loss	Factor	Pos	Pos	Avg.	
1		(MHz)	(dBμV/m)	(dB)	(dBμV/m)	(dBμV)	(dB/m)	(dB)	(dB)	(cm)	(deg)	(P/A)	(H/V)
802.11a CH 100 5500MHz		5450.32	50.66	-23.34	74	41.38	32.34	7.54	30.6	115	180	P	H
		5463.28	50.45	-17.75	68.2	41.16	32.36	7.54	30.61	115	180	P	H
		5460	39.9	-14.1	54	30.62	32.34	7.54	30.6	115	180	A	H
	*	5500	99.8	-	-	90.43	32.4	7.58	30.61	115	180	P	H
	*	5500	91.74	-	-	82.37	32.4	7.58	30.61	115	180	A	H
		5458.16	50.96	-23.04	74	41.68	32.34	7.54	30.6	100	108	P	V
		5461.52	51.43	-16.77	68.2	42.15	32.34	7.54	30.6	100	108	P	V
		5459.76	40.92	-13.08	54	31.64	32.34	7.54	30.6	100	108	A	V
	*	5500	104.73	-	-	95.36	32.4	7.58	30.61	100	108	P	V
	*	5500	96.6	-	-	87.23	32.4	7.58	30.61	100	108	A	V
802.11a CH 116 5580MHz		5392.24	50.29	-23.71	74	41.15	32.26	7.48	30.6	127	179	P	H
		5464.24	49.98	-18.22	68.2	40.69	32.36	7.54	30.61	127	179	P	H
		5459.44	39.73	-14.27	54	30.45	32.34	7.54	30.6	127	179	A	H
	*	5580	98.84	-	-	89.35	32.47	7.66	30.64	127	179	P	H
	*	5580	91.48	-	-	81.99	32.47	7.66	30.64	127	179	A	H
		5736.65	50.1	-18.1	68.2	40.34	32.64	7.83	30.71	127	179	P	H
		5450.8	50.84	-23.16	74	41.56	32.34	7.54	30.6	105	105	P	V
		5469.28	50.72	-17.48	68.2	41.41	32.36	7.56	30.61	105	105	P	V
		5459.92	40.55	-13.45	54	31.27	32.34	7.54	30.6	105	105	A	V
	*	5580	104.54	-	-	95.05	32.47	7.66	30.64	105	105	P	V
	*	5580	97.12	-	-	87.63	32.47	7.66	30.64	105	105	A	V
	5750.51	50.67	-17.53	68.2	40.93	32.64	7.83	30.73	105	105	P	V	



802.11a CH 140 5700MHz	*	5700	100.13	-	-	90.45	32.59	7.79	30.7	100	127	P	H
	*	5700	92.44	-	-	82.76	32.59	7.79	30.7	100	127	A	H
		5761.16	50.41	-17.79	68.2	40.64	32.66	7.84	30.73	100	127	P	H
	*	5700	105.72	-	-	96.04	32.59	7.79	30.7	100	106	P	V
	*	5700	98.01	-	-	88.33	32.59	7.79	30.7	100	106	A	V
		5737.8	51.24	-16.96	68.2	41.5	32.64	7.83	30.73	100	106	P	V
Remark	<p>1. No other spurious found.</p> <p>2. All results are PASS against Peak and Average limit line.</p>												



**Band 3 - 5470~5725MHz
WIFI 802.11a (Harmonic @ 3m)**

WIFI Ant. 1	Note	Frequency (MHz)	Level (dBμV/m)	Over Limit (dB)	Limit Line (dBμV/m)	Read Level (dBμV)	Antenna Factor (dB/m)	Cable Loss (dB)	Preamp Factor (dB)	Ant Pos (cm)	Table Pos (deg)	Peak Avg. (P/A)	Pol. (H/V)
802.11a CH 100 5500MHz		11000	49.79	-24.21	74	54.61	40.1	11.16	56.6	100	0	P	H
		16500	47.32	-20.88	68.2	50.75	38.3	13.28	55.7	100	0	P	H
		11000	47.08	-26.92	74	51.9	40.1	11.16	56.6	100	0	P	V
		16500	45.57	-22.63	68.2	49	38.3	13.28	55.7	100	0	P	V
802.11a CH 116 5580MHz		11160	52.85	-21.15	74	57.63	40.03	11.2	56.53	372	25	P	H
		11160	44.46	-9.54	54	49.24	40.03	11.2	56.53	372	25	A	H
		16740	45.68	-22.52	68.2	48.4	39.12	13.29	55.8	100	0	P	H
		11160	47.47	-26.53	74	52.25	40.03	11.2	56.53	100	0	P	V
		16740	46.21	-21.99	68.2	48.93	39.12	13.29	55.8	100	0	P	V
802.11a CH 140 5700MHz		11400	52	-22	74	56.71	39.94	11.27	56.44	313	5	P	H
		11400	44.18	-9.82	54	48.89	39.94	11.27	56.44	313	5	A	H
		17100	48.15	-20.05	68.2	49.95	40.24	13.37	56.06	100	0	P	H
		11400	46.88	-27.12	74	51.59	39.94	11.27	56.44	100	0	P	V
		17100	47.57	-20.63	68.2	49.37	40.24	13.37	56.06	100	0	P	V
Remark	1. No other spurious found. 2. All results are PASS against Peak and Average limit line.												



**Band 3 - 5470~5725MHz
WIFI 802.11n HT20 (Band Edge @ 3m)**

WIFI Ant. 1	Note	Frequency (MHz)	Level (dBμV/m)	Over Limit (dB)	Limit Line (dBμV/m)	Read Level (dBμV)	Antenna Factor (dB/m)	Cable Loss (dB)	Preamp Factor (dB)	Ant Pos (cm)	Table Pos (deg)	Peak Avg. (P/A)	Pol. (H/V)
802.11n HT20 CH 100 5500MHz		5439.92	49.68	-24.32	74	40.44	32.32	7.52	30.6	115	180	P	H
		5460.56	50.01	-18.19	68.2	40.73	32.34	7.54	30.6	115	180	P	H
		5458.16	39.92	-14.08	54	30.64	32.34	7.54	30.6	115	180	A	H
	*	5500	99.97	-	-	90.6	32.4	7.58	30.61	115	180	P	H
	*	5500	93.16	-	-	83.79	32.4	7.58	30.61	115	180	A	H
		5454.48	51.09	-22.91	74	41.81	32.34	7.54	30.6	100	107	P	V
		5468.08	51.34	-16.86	68.2	42.03	32.36	7.56	30.61	100	107	P	V
		5459.92	40.99	-13.01	54	31.71	32.34	7.54	30.6	100	107	A	V
	*	5500	104.71	-	-	95.34	32.4	7.58	30.61	100	107	P	V
	*	5500	98.31	-	-	88.94	32.4	7.58	30.61	100	107	A	V
802.11n HT20 CH 116 5580MHz		5430.88	49.07	-24.93	74	39.83	32.32	7.52	30.6	111	167	P	H
		5464.48	47.44	-20.76	68.2	38.15	32.36	7.54	30.61	111	167	P	H
		5459.92	39.71	-14.29	54	30.43	32.34	7.54	30.6	111	167	A	H
	*	5580	98.74	-	-	89.25	32.47	7.66	30.64	111	167	P	H
	*	5580	92.08	-	-	82.59	32.47	7.66	30.64	111	167	A	H
		5762.48	49.16	-19.04	68.2	39.39	32.66	7.84	30.73	111	167	P	H
		5453.68	51.16	-22.84	74	41.88	32.34	7.54	30.6	109	104	P	V
		5463.28	51.74	-16.46	68.2	42.45	32.36	7.54	30.61	109	104	P	V
		5459.92	40.55	-13.45	54	31.27	32.34	7.54	30.6	109	104	A	V
	*	5580	104.72	-	-	95.23	32.47	7.66	30.64	109	104	P	V
	*	5580	97.93	-	-	88.44	32.47	7.66	30.64	109	104	A	V
	5749.25	50.19	-18.01	68.2	40.45	32.64	7.83	30.73	109	104	P	V	



802.11n	*	5700	100.39	-	-	90.71	32.59	7.79	30.7	100	127	P	H
	*	5700	93.32	-	-	83.64	32.59	7.79	30.7	100	127	A	H
HT20		5753.96	50.84	-17.36	68.2	41.07	32.66	7.84	30.73	100	127	P	H
CH 140	*	5700	104.93	-	-	95.25	32.59	7.79	30.7	100	104	P	V
5700MHz	*	5700	98	-	-	88.32	32.59	7.79	30.7	100	104	A	V
		5727.08	57.52	-10.68	68.2	47.8	32.62	7.81	30.71	100	104	P	V
Remark	1. No other spurious found. 2. All results are PASS against Peak and Average limit line.												



**Band 3 - 5470~5725MHz
WIFI 802.11n HT20 (Harmonic @ 3m)**

WIFI Ant. 1	Note	Frequency (MHz)	Level (dBμV/m)	Over Limit (dB)	Limit Line (dBμV/m)	Read Level (dBμV)	Antenna Factor (dB/m)	Cable Loss (dB)	Preamp Factor (dB)	Ant Pos (cm)	Table Pos (deg)	Peak Avg. (P/A)	Pol. (H/V)
802.11n HT20 CH 100 5500MHz		11000	51.38	-22.62	74	56.2	40.1	11.16	56.6	343	31	P	H
		11000	43.22	-10.78	54	48.04	40.1	11.16	56.6	343	31	A	H
		16500	46.95	-21.25	68.2	50.38	38.3	13.28	55.7	100	0	P	H
		11000	49.31	-24.69	74	54.13	40.1	11.16	56.6	100	0	P	V
		16500	45.88	-22.32	68.2	49.31	38.3	13.28	55.7	100	0	P	V
802.11n HT20 CH 116 5580MHz		11160	51.91	-22.09	74	56.69	40.03	11.2	56.53	268	14	P	H
		11160	43.47	-10.53	54	48.25	40.03	11.2	56.53	268	14	A	H
		16740	46.44	-21.76	68.2	49.16	39.12	13.29	55.8	100	0	P	H
		11160	47.53	-26.47	74	52.31	40.03	11.2	56.53	100	0	P	V
		16740	46.01	-22.19	68.2	48.73	39.12	13.29	55.8	100	0	P	V
802.11n HT20 CH 140 5700MHz		11400	49.63	-24.37	74	54.34	39.94	11.27	56.44	100	0	P	H
		17100	48.87	-19.33	68.2	50.67	40.24	13.37	56.06	100	0	P	H
		11400	46.79	-27.21	74	51.5	39.94	11.27	56.44	100	0	P	V
		17100	48.43	-19.77	68.2	50.23	40.24	13.37	56.06	100	0	P	V
Remark	1. No other spurious found. 2. All results are PASS against Peak and Average limit line.												



**Band 3 - 5470~5725MHz
WIFI 802.11n HT40 (Band Edge @ 3m)**

WIFI Ant. 1	Note	Frequency (MHz)	Level (dBμV/m)	Over Limit (dB)	Limit Line (dBμV/m)	Read Level (dBμV)	Antenna Factor (dB/m)	Cable Loss (dB)	Preamp Factor (dB)	Ant Pos (cm)	Table Pos (deg)	Peak Avg. (P/A)	Pol. (H/V)
802.11n HT40 CH 102 5510MHz		5445.28	50.24	-23.76	74	41	32.32	7.52	30.6	100	126	P	H
		5468.32	53.47	-14.73	68.2	44.16	32.36	7.56	30.61	100	126	P	H
		5459.92	40.53	-13.47	54	31.25	32.34	7.54	30.6	100	126	A	H
	*	5510	99.06	-	-	89.68	32.4	7.59	30.61	100	126	P	H
	*	5510	90.51	-	-	81.13	32.4	7.59	30.61	100	126	A	H
		5742.95	50.62	-17.58	68.2	40.88	32.64	7.83	30.73	100	126	P	H
		5456.08	53.08	-20.92	74	43.8	32.34	7.54	30.6	100	106	P	V
		5468.8	59.64	-8.56	68.2	50.33	32.36	7.56	30.61	100	106	P	V
		5459.92	42.87	-11.13	54	33.59	32.34	7.54	30.6	100	106	A	V
	*	5510	104.09	-	-	94.71	32.4	7.59	30.61	100	106	P	V
	*	5510	96.59	-	-	87.21	32.4	7.59	30.61	100	106	A	V
		5731.925	51.51	-16.69	68.2	41.79	32.62	7.81	30.71	100	106	P	V
802.11n HT40 CH 110 5550MHz		5441.92	49.94	-24.06	74	40.7	32.32	7.52	30.6	100	124	P	H
		5468.08	49.37	-18.83	68.2	40.06	32.36	7.56	30.61	100	124	P	H
		5459.92	39.9	-14.1	54	30.62	32.34	7.54	30.6	100	124	A	H
	*	5550	96.99	-	-	87.54	32.45	7.63	30.63	100	124	P	H
	*	5550	89.05	-	-	79.6	32.45	7.63	30.63	100	124	A	H
		5747.045	48.53	-19.67	68.2	38.79	32.64	7.83	30.73	100	124	P	H
		5435.68	51.31	-22.69	74	42.07	32.32	7.52	30.6	100	101	P	V
		5462.08	51.35	-16.85	68.2	42.07	32.34	7.54	30.6	100	101	P	V
		5459.44	40.76	-13.24	54	31.48	32.34	7.54	30.6	100	101	A	V
	*	5550	102.6	-	-	93.15	32.45	7.63	30.63	100	101	P	V
	*	5550	95.28	-	-	85.83	32.45	7.63	30.63	100	101	A	V
		5729.09	49.31	-18.89	68.2	39.59	32.62	7.81	30.71	100	101	P	V



802.11n HT40 CH 134 5670MHz		5418.6	48.67	-25.33	74	39.46	32.3	7.51	30.6	102	128	P	H
		5464.8	48.57	-19.63	68.2	39.28	32.36	7.54	30.61	102	128	P	H
		5459.55	39.71	-14.29	54	30.43	32.34	7.54	30.6	102	128	A	H
	*	5670	97.73	-	-	88.1	32.57	7.75	30.69	102	128	P	H
	*	5670	90.62	-	-	80.99	32.57	7.75	30.69	102	128	A	H
		5730.98	50.72	-17.48	68.2	41	32.62	7.81	30.71	102	128	P	H
		5447.3	50.11	-23.89	74	40.85	32.34	7.52	30.6	120	105	P	V
		5463.05	49.57	-18.63	68.2	40.28	32.36	7.54	30.61	120	105	P	V
		5459.9	40.37	-13.63	54	31.09	32.34	7.54	30.6	120	105	A	V
	*	5670	103.46	-	-	93.83	32.57	7.75	30.69	120	105	P	V
	*	5670	96.25	-	-	86.62	32.57	7.75	30.69	120	105	A	V
		5740.745	51.42	-16.78	68.2	41.68	32.64	7.83	30.73	120	105	P	V
Remark	1. No other spurious found. 2. All results are PASS against Peak and Average limit line.												



**Band 3 - 5470~5725MHz
WIFI 802.11n HT40 (Harmonic @ 3m)**

WIFI Ant. 1	Note	Frequency (MHz)	Level (dBμV/m)	Over Limit (dB)	Limit Line (dBμV/m)	Read Level (dBμV)	Antenna Factor (dB/m)	Cable Loss (dB)	Preamp Factor (dB)	Ant Pos (cm)	Table Pos (deg)	Peak Avg. (P/A)	Pol. (H/V)
802.11n HT40 CH 102		11020	48.71	-25.29	74	53.52	40.09	11.17	56.59	100	0	P	H
		16530	46.06	-22.14	68.2	49.38	38.42	13.28	55.71	100	0	P	H
5510MHz		11020	46.92	-27.08	74	51.73	40.09	11.17	56.59	100	0	P	V
		16530	46.92	-21.28	68.2	50.24	38.42	13.28	55.71	100	0	P	V
802.11n HT40 CH 110		11100	50.04	-23.96	74	54.83	40.06	11.19	56.56	361	28	P	H
		11100	42.22	-11.78	54	47.01	40.06	11.19	56.56	361	28	A	H
		16650	46.37	-21.83	68.2	49.33	38.83	13.29	55.76	100	0	P	H
		11100	47.93	-26.07	74	52.72	40.06	11.19	56.56	100	0	P	V
		16650	46.91	-21.29	68.2	49.87	38.83	13.29	55.76	100	0	P	V
802.11n HT40 CH 134		11340	48.24	-25.76	74	52.97	39.97	11.25	56.47	100	0	P	H
		17010	47.21	-20.99	68.2	49.14	40.04	13.31	55.93	100	0	P	H
		11340	46.87	-27.13	74	51.6	39.97	11.25	56.47	100	0	P	V
		17010	47.22	-20.98	68.2	49.15	40.04	13.31	55.93	100	0	P	V
Remark	1. No other spurious found. 2. All results are PASS against Peak and Average limit line.												



**Band 3 - 5470~5725MHz
WIFI 802.11ac VHT80 (Band Edge @ 3m)**

WIFI Ant. 1	Note	Frequency (MHz)	Level (dBμV/m)	Over Limit (dB)	Limit Line (dBμV/m)	Read Level (dBμV)	Antenna Factor (dB/m)	Cable Loss (dB)	Preamp Factor (dB)	Ant Pos (cm)	Table Pos (deg)	Peak Avg. (P/A)	Pol. (H/V)
802.11ac VHT80 CH 106 5530MHz		5446.24	52.61	-21.39	74	43.35	32.34	7.52	30.6	200	131	P	H
		5469.76	56.12	-12.08	68.2	46.81	32.36	7.56	30.61	200	131	P	H
		5459.92	43.26	-10.74	54	33.98	32.34	7.54	30.6	200	131	A	H
	*	5530	94.89	-	-	85.48	32.42	7.61	30.62	200	131	P	H
	*	5530	86.09	-	-	76.68	32.42	7.61	30.62	200	131	A	H
		5743.265	50.24	-17.96	68.2	40.5	32.64	7.83	30.73	200	131	P	H
		5455.36	55.61	-18.39	74	46.33	32.34	7.54	30.6	227	125	P	V
		5467.12	56.37	-11.83	68.2	47.06	32.36	7.56	30.61	227	125	P	V
		5458.48	45.54	-8.46	54	36.26	32.34	7.54	30.6	227	125	A	V
	*	5530	97.79	-	-	88.38	32.42	7.61	30.62	227	125	P	V
	*	5530	89.84	-	-	80.43	32.42	7.61	30.62	227	125	A	V
		5728.775	50.35	-17.85	68.2	40.63	32.62	7.81	30.71	227	125	P	V
802.11ac VHT80 CH 122 5610MHz		5449.12	48.86	-25.14	74	39.58	32.34	7.54	30.6	225	133	P	H
		5468.32	48.44	-19.76	68.2	39.13	32.36	7.56	30.61	225	133	P	H
		5459.92	39.89	-14.11	54	30.61	32.34	7.54	30.6	225	133	A	H
	*	5610	94.85	-	-	85.31	32.5	7.7	30.66	225	133	P	H
	*	5610	86.57	-	-	77.03	32.5	7.7	30.66	225	133	A	H
		5762.795	49.83	-18.37	68.2	40.07	32.66	7.84	30.74	225	133	P	H
		5452.96	50.14	-23.86	74	40.86	32.34	7.54	30.6	222	125	P	V
		5465.92	50	-18.2	68.2	40.71	32.36	7.54	30.61	222	125	P	V
		5458.96	40.37	-13.63	54	31.09	32.34	7.54	30.6	222	125	A	V
	*	5610	97.71	-	-	88.17	32.5	7.7	30.66	222	125	P	V
	*	5610	89.51	-	-	79.97	32.5	7.7	30.66	222	125	A	V
		5727.83	50.42	-17.78	68.2	40.7	32.62	7.81	30.71	222	125	P	V
Remark	1. No other spurious found. 2. All results are PASS against Peak and Average limit line.												



**Band 3 5470~5725MHz
WIFI 802.11ac VHT80 (Harmonic @ 3m)**

WIFI Ant. 1	Note	Frequency (MHz)	Level (dBμV/m)	Over Limit (dB)	Limit Line (dBμV/m)	Read Level (dBμV)	Antenna Factor (dB/m)	Cable Loss (dB)	Preamp Factor (dB)	Ant Pos (cm)	Table Pos (deg)	Peak Avg. (P/A)	Pol. (H/V)
802.11ac		11060	47.72	-26.28	74	52.52	40.07	11.18	56.57	100	0	P	H
VHT80		16590	45.37	-22.83	68.2	48.55	38.59	13.28	55.73	100	0	P	H
CH 106		11060	46.74	-27.26	74	51.54	40.07	11.18	56.57	100	0	P	V
5530MHz		16590	46.33	-21.87	68.2	49.51	38.59	13.28	55.73	100	0	P	V
802.11ac		11220	47.4	-26.6	74	52.16	40.01	11.22	56.51	100	0	P	H
VHT80		16830	47.51	-20.69	68.2	49.97	39.41	13.29	55.83	100	0	P	H
CH 122		11220	46.93	-27.07	74	51.69	40.01	11.22	56.51	100	0	P	V
5610MHz		16830	46.48	-21.72	68.2	48.94	39.41	13.29	55.83	100	0	P	V
Remark	1. No other spurious found. 2. All results are PASS against Peak and Average limit line.												



Band 3 - Straddle Channel
WIFI 802.11a (Band Edge @ 3m)

WIFI	Note	Frequency	Level	Over	Limit	Read	Antenna	Cable	Preamp	Ant	Table	Peak	Pol.
Ant.				Limit	Line	Level	Factor	Loss	Factor	Pos	Pos	Avg.	
1		(MHz)	(dBμV/m)	(dB)	(dBμV/m)	(dBμV)	(dB/m)	(dB)	(dB)	(cm)	(deg)	(P/A)	(H/V)
802.11a CH 144 5720MHz		5372.8	49.07	-24.93	74	39.95	32.24	7.47	30.59	216	277	P	H
		5461.6	50.22	-17.98	68.2	40.94	32.34	7.54	30.6	220	279	P	H
		5459.8	39.7	-14.3	54	30.42	32.34	7.54	30.6	216	277	A	H
	*	5720	101.43	-	-	91.71	32.62	7.81	30.71	216	277	P	H
	*	5720	93.44	-	-	83.72	32.62	7.81	30.71	216	277	A	H
		5872.6	51.32	-16.88	68.2	41.44	32.78	7.88	30.78	216	277	P	H
		5451.4	48.88	-25.12	74	39.6	32.34	7.54	30.6	267	151	P	V
		5460	47.68	-20.52	68.2	38.4	32.34	7.54	30.6	267	151	P	V
		5459.8	39.87	-14.13	54	30.59	32.34	7.54	30.6	267	151	A	V
	*	5720	104.66	-	-	94.94	32.62	7.81	30.71	267	151	P	V
	*	5720	97.54	-	-	87.82	32.62	7.81	30.71	267	151	A	V
		5944.6	50.98	-17.22	68.2	41.06	32.85	7.89	30.82	267	151	P	V
Remark	1. No other spurious found. 2. All results are PASS against Peak and Average limit line.												



Band 3 - Straddle Channel
WIFI 802.11a (Harmonic @ 3m)

Table with 14 columns: WIFI Ant. 1, Note, Frequency (MHz), Level (dBµV/m), Over Limit (dB), Limit Line (dBµV/m), Read Level (dBµV), Antenna Factor (dB/m), Cable Loss (dB), Preamp Factor (dB), Ant Pos (cm), Table Pos (deg), Peak Avg. (P/A), Pol. (H/V). Rows include data for 802.11a CH 144 at 5720MHz and a Remark section.



**Band 3 - Straddle Channel
WIFI 802.11n HT20 (Band Edge @ 3m)**

WIFI Ant. 1	Note	Frequency (MHz)	Level (dBμV/m)	Over Limit (dB)	Limit Line (dBμV/m)	Read Level (dBμV)	Antenna Factor (dB/m)	Cable Loss (dB)	Preamp Factor (dB)	Ant Pos (cm)	Table Pos (deg)	Peak Avg. (P/A)	Pol. (H/V)
802.11n HT20 CH 144 5720MHz		5426.2	49.55	-24.45	74	40.34	32.3	7.51	30.6	209	280	P	H
		5469.4	48.77	-19.43	68.2	39.46	32.36	7.56	30.61	209	280	P	H
		5459.8	39.59	-14.41	54	30.31	32.34	7.54	30.6	209	280	A	H
	*	5720	101.62	-	-	91.9	32.62	7.81	30.71	209	280	P	H
	*	5720	94.29	-	-	84.57	32.62	7.81	30.71	209	280	A	H
		5870.8	51.05	-17.15	68.2	41.17	32.78	7.88	30.78	209	280	P	H
		5447.2	48.77	-25.23	74	39.51	32.34	7.52	30.6	252	147	P	V
		5460	48.62	-19.58	68.2	39.34	32.34	7.54	30.6	252	147	P	V
		5459.2	39.74	-14.26	54	30.46	32.34	7.54	30.6	252	147	A	V
	*	5720	104.2	-	-	94.48	32.62	7.81	30.71	252	147	P	V
	*	5720	97.09	-	-	87.37	32.62	7.81	30.71	252	147	A	V
		5916.4	51.27	-16.93	68.2	41.38	32.81	7.89	30.81	252	147	P	V
Remark	1. No other spurious found. 2. All results are PASS against Peak and Average limit line.												



Band 3 - Straddle Channel
WIFI 802.11n HT20 (Harmonic @ 3m)

Table with 14 columns: WIFI Ant. 1, Note, Frequency (MHz), Level (dBµV/m), Over Limit (dB), Limit Line (dBµV/m), Read Level (dBµV), Antenna Factor (dB/m), Cable Loss (dB), Preamp Factor (dB), Ant Pos (cm), Table Pos (deg), Peak Avg. (P/A), Pol. (H/V). Rows include test data for 802.11n HT20 CH 144 5720MHz and a Remark section.



**Band 3 - Straddle Channel
WIFI 802.11n HT40 (Band Edge @ 3m)**

WIFI Ant. 1	Note	Frequency (MHz)	Level (dBμV/m)	Over Limit (dB)	Limit Line (dBμV/m)	Read Level (dBμV)	Antenna Factor (dB/m)	Cable Loss (dB)	Preamp Factor (dB)	Ant Pos (cm)	Table Pos (deg)	Peak Avg. (P/A)	Pol. (H/V)
802.11n HT40 CH 142 5710MHz		5444.2	48.95	-25.05	74	39.71	32.32	7.52	30.6	227	279	P	H
		5465.2	50.03	-18.17	68.2	40.74	32.36	7.54	30.61	227	279	P	H
		5459.2	39.59	-14.41	54	30.31	32.34	7.54	30.6	227	279	A	H
	*	5710	99.32	-	-	89.62	32.61	7.79	30.7	227	279	P	H
	*	5710	91.7	-	-	82	32.61	7.79	30.7	227	279	A	H
		5863	50.53	-17.67	68.2	40.67	32.76	7.88	30.78	227	279	P	H
		5456.2	49.3	-24.7	74	40.02	32.34	7.54	30.6	100	67	P	V
		5468.8	49.6	-18.6	68.2	40.29	32.36	7.56	30.61	100	67	P	V
		5459.2	39.53	-14.47	54	30.25	32.34	7.54	30.6	100	67	A	V
	*	5710	100.72	-	-	91.02	32.61	7.79	30.7	100	67	P	V
	*	5710	92.93	-	-	83.23	32.61	7.79	30.7	100	67	A	V
		5936.8	51.59	-16.61	68.2	41.68	32.83	7.89	30.81	100	67	P	V
Remark	1. No other spurious found. 2. All results are PASS against Peak and Average limit line.												



Band 3 - Straddle Channel
WIFI 802.11n HT40 (Harmonic @ 3m)

Table with 14 columns: WIFI Ant. 1, Note, Frequency (MHz), Level (dBµV/m), Over Limit (dB), Limit Line (dBµV/m), Read Level (dBµV), Antenna Factor (dB/m), Cable Loss (dB), Preamp Factor (dB), Ant Pos (cm), Table Pos (deg), Peak Avg. (P/A), Pol. (H/V). Rows include data for 802.11n HT40 and 5710MHz channels, and a Remark section.



**Band 3 - Straddle Channel
WIFI 802.11ac VHT80 (Band Edge @ 3m)**

WIFI Ant. 1	Note	Frequency (MHz)	Level (dBμV/m)	Over Limit (dB)	Limit Line (dBμV/m)	Read Level (dBμV)	Antenna Factor (dB/m)	Cable Loss (dB)	Preamp Factor (dB)	Ant Pos (cm)	Table Pos (deg)	Peak Avg. (P/A)	Pol. (H/V)
802.11ac VHT80 CH 138 5690MHz		5458	49.19	-24.81	74	39.91	32.34	7.54	30.6	213	133	P	H
		5467	48.19	-20.01	68.2	38.88	32.36	7.56	30.61	213	133	P	H
		5457.4	39.5	-14.5	54	30.22	32.34	7.54	30.6	213	133	A	H
	*	5690	95.5	-	-	85.84	32.59	7.77	30.7	213	133	P	H
	*	5690	87.32	-	-	77.66	32.59	7.77	30.7	213	133	A	H
		5884	50.31	-17.89	68.2	40.43	32.78	7.88	30.78	213	133	P	H
		5360.2	49.78	-24.22	74	40.68	32.22	7.47	30.59	225	127	P	V
		5462.2	49.87	-18.33	68.2	40.59	32.34	7.54	30.6	225	127	P	V
		5458.6	39.76	-14.24	54	30.48	32.34	7.54	30.6	225	127	A	V
	*	5690	98.46	-	-	88.8	32.59	7.77	30.7	225	127	P	V
	*	5690	90.24	-	-	80.58	32.59	7.77	30.7	225	127	A	V
	5878.6	50.93	-17.27	68.2	41.05	32.78	7.88	30.78	225	127	P	V	
Remark	1. No other spurious found. 2. All results are PASS against Peak and Average limit line.												



Band 3 - Straddle Channel
WIFI 802.11ac VHT80 (Harmonic @ 3m)

Table with 14 columns: WIFI Ant. 1, Note, Frequency (MHz), Level (dBµV/m), Over Limit (dB), Limit Line (dBµV/m), Read Level (dBµV), Antenna Factor (dB/m), Cable Loss (dB), Preamp Factor (dB), Ant Pos (cm), Table Pos (deg), Peak Avg. (P/A), Pol. (H/V). Rows include 802.11ac, VHT80, CH 138, 5690MHz and a Remark section.



Emission below 1GHz
WIFI 802.11ac VHT80 (LF @ 3m)

Table with 14 columns: WIFI Ant., Note, Frequency, Level, Over Limit, Limit Line, Read Level, Antenna Factor, Cable Loss, Preamp Factor, Ant Pos, Table Pos, Peak Avg., Pol. It contains 12 rows of test data for 802.11ac VHT80 LF and a Remark section at the bottom.



Note symbol

*	Fundamental Frequency which can be ignored. However, the level of any unwanted emissions shall not exceed the level of the fundamental frequency.
!	Test result is over limit line.
P/A	Peak or Average
H/V	Horizontal or Vertical



A calculation example for radiated spurious emission is shown as below:

WIFI	Note	Frequency	Level	Over	Limit	Read	Antenna	Cable	Preamp	Ant	Table	Peak	Pol.
Ant.				Limit	Line	Level	Factor	Loss	Factor	Pos	Pos	Avg.	
1		(MHz)	(dBμV/m)	(dB)	(dBμV/m)	(dBμV)	(dB/m)	(dB)	(dB)	(cm)	(deg)	(P/A)	(H/V)
802.11b		2390	55.45	-18.55	74	54.51	32.22	4.58	35.86	103	308	P	H
CH 01													
2412MHz		2390	43.54	-10.46	54	42.6	32.22	4.58	35.86	103	308	A	H

- Level(dBμV/m) =
Antenna Factor(dB/m) + Cable Loss(dB) + Read Level(dBμV) - Preamp Factor(dB)
- Over Limit(dB) = Level(dBμV/m) – Limit Line(dBμV/m)

For Peak Limit @ 2390MHz:

- Level(dBμV/m)
= Antenna Factor(dB/m) + Cable Loss(dB) + Read Level(dBμV) - Preamp Factor(dB)
= 32.22(dB/m) + 4.58(dB) + 54.51(dBμV) – 35.86 (dB)
= 55.45 (dBμV/m)
- Over Limit(dB)
= Level(dBμV/m) – Limit Line(dBμV/m)
= 55.45(dBμV/m) – 74(dBμV/m)
= -18.55(dB)

For Average Limit @ 2390MHz:

- Level(dBμV/m)
= Antenna Factor(dB/m) + Cable Loss(dB) + Read Level(dBμV) - Preamp Factor(dB)
= 32.22(dB/m) + 4.58(dB) + 42.6(dBμV) – 35.86 (dB)
= 43.54 (dBμV/m)
- Over Limit(dB)
= Level(dBμV/m) – Limit Line(dBμV/m)
= 43.54(dBμV/m) – 54(dBμV/m)
= -10.46(dB)

Both peak and average measured complies with the limit line, so test result is “PASS”.



Appendix C. Radiated Spurious Emission

Test Engineer :	Alex Jheng, Bill Chang, and Wilson Wu	Temperature :	24.0~24.1°C
		Relative Humidity :	52~53%

Note symbol

-L	Low channel location
-R	High channel location



Band 2 - 5250~5350MHz
WIFI 802.11a (Band Edge @ 3m)

WIFI	Band 2 5250~5350MHz Band Edge @ 3m	
ANT	802.11a CH52 5260MHz - L	
1	Horizontal	Fundamental
Peak	<p>Site : 03CH13-HY Condition : PEAK_BE_74 3m HORN_91200_1241 HORIZONTAL Detector : Peak Project : 671336-04 Mode : 1 Power : 15</p>	<p>Site : 03CH13-HY Condition : PEAK_F4 3m HORN_91200_1241 HORIZONTAL Detector : Peak Project : 671336-04 Mode : 1 Power : 15</p>
Avg.	<p>Site : 03CH13-HY Condition : AVG_BE_54 3m HORN_91200_1241 HORIZONTAL Detector : Peak Project : 671336-04 Mode : 1 Power : 15</p>	Left blank

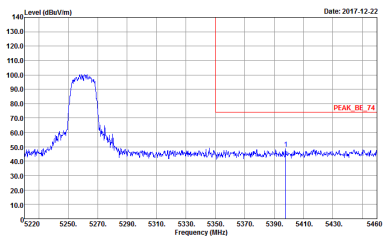
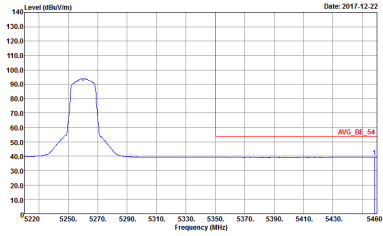

WIFI	Band 2 5250~5350MHz Band Edge @ 3m	
ANT	802.11a CH52 5260MHz - R	
1	Horizontal	Fundamental
<p>Peak</p>	 <p>Site : 03CH13-HY Condition : PEAK_BE_74 3m HORN_91200_1241 HORIZONTAL : RBW:1000.000KHz VBW:3000.000KHz SWT:Auto Detector : Peak Project : 671336-04 Mode : 1 Power : 15</p>	<p>Left blank</p>
<p>Avg.</p>	 <p>Site : 03CH13-HY Condition : AVG_BE_54 3m HORN_91200_1241 HORIZONTAL : RBW:1000.000KHz VBW:3000.000KHz SWT:Auto Detector : Peak Project : 671336-04 Mode : 1 Power : 15</p>	<p>Left blank</p>

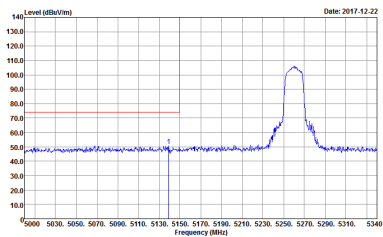
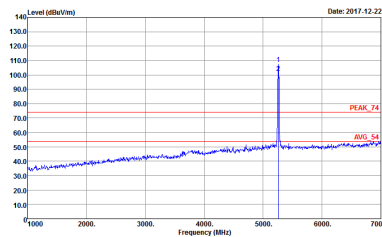
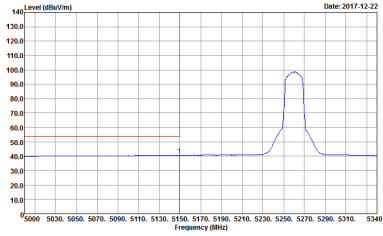

WIFI	Band 2 5250~5350MHz Band Edge @ 3m	
ANT	802.11a CH52 5260MHz - L	
1	Vertical	Fundamental
Peak	 <p>Site : 03CH13-HY Condition : PEAK_BE_74 3m HORN_9120D_1241 VERTICAL : RBW:1000.000KHz VBW:3000.000KHz SWT:Auto Detector : Peak Project : 671336-04 Mode : 1 Power : 15</p>	 <p>Site : 03CH13-HY Condition : PEAK_74 3m HORN_9120D_1241 VERTICAL : RBW:1000.000KHz VBW:3000.000KHz SWT:Auto Detector : Peak Project : 671336-04 Mode : 1 Power : 15</p>
Avg.	 <p>Site : 03CH13-HY Condition : AVG_BE_54 3m HORN_9120D_1241 VERTICAL : RBW:1000.000KHz VBW:3000.000KHz SWT:Auto Detector : Peak Project : 671336-04 Mode : 1 Power : 15</p>	Left blank



WIFI	Band 2 5250~5350MHz Band Edge @ 3m	
ANT	802.11a CH52 5260MHz - R	
1	Vertical	Fundamental
<p>Peak</p>	<p>Site : 03CH13-HY Condition : PEAK_BE_74 3m HORN_91200_1241 VERTICAL Detector : Peak Project : 671336-04 Mode : 1 Power : 15</p>	<p>Left blank</p>
<p>Avg.</p>	<p>Site : 03CH13-HY Condition : AVG_BE_54 3m HORN_91200_1241 VERTICAL Detector : Peak Project : 671336-04 Mode : 1 Power : 15</p>	<p>Left blank</p>

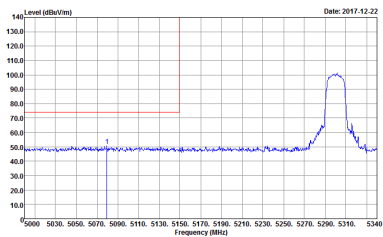
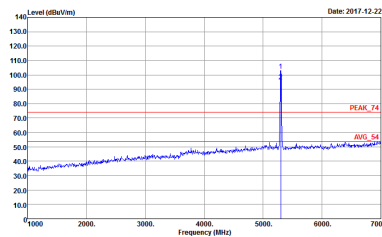
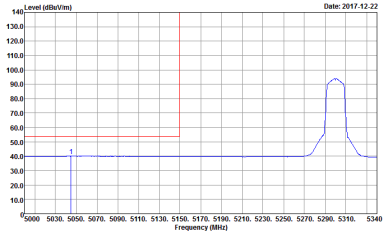

WIFI	Band 2 5250~5350MHz Band Edge @ 3m	
ANT	802.11a CH60 5300MHz - L	
1	Horizontal	Fundamental
Peak	 <p>Date: 2017-12-22</p> <p>Site : 03CH13-HY Condition : PEAK_BE_74 3m HORN_9120D_1241 HORIZONTAL RBW:1000.000KHz VBW:3000.000KHz SWT:Auto Detector : Peak Project : 671336-04 Mode : 2 Power : 15</p>	 <p>Date: 2017-12-22</p> <p>Site : 03CH13-HY Condition : PEAK_74 3m HORN_9120D_1241 HORIZONTAL RBW:1000.000KHz VBW:3000.000KHz SWT:Auto Detector : Peak Project : 671336-04 Mode : 2 Power : 15</p>
Avg.	 <p>Date: 2017-12-22</p> <p>Site : 03CH13-HY Condition : AVG_BE_54 3m HORN_9120D_1241 HORIZONTAL RBW:1000.000KHz VBW:3000.000KHz SWT:Auto Detector : Peak Project : 671336-04 Mode : 2 Power : 15</p>	Left blank

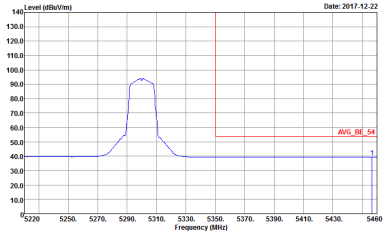

WIFI	Band 2 5250~5350MHz Band Edge @ 3m	
ANT	802.11a CH60 5300MHz - R	
1	Horizontal	Fundamental
Peak	 <p>Site : 03CH13-HY Condition : PEAK_BE_74 3m HORN_91200_1241 HORIZONTAL : RBW:1000.000KHz VBW:3000.000KHz SWT:Auto Detector : Peak Project : 671336-04 Mode : 2 Power : 15</p>	Left blank
Avg.	 <p>Site : 03CH13-HY Condition : AVG_BE_54 3m HORN_91200_1241 HORIZONTAL : RBW:1000.000KHz VBW:3000.000KHz SWT:Auto Detector : Peak Project : 671336-04 Mode : 2 Power : 15</p>	Left blank

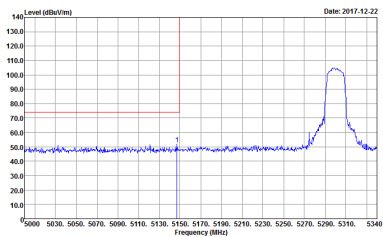
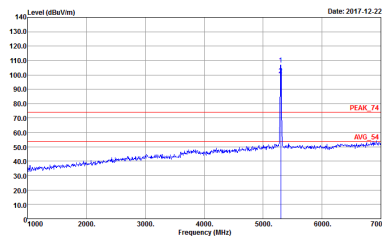
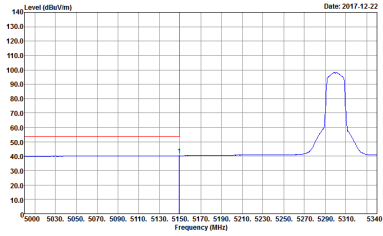

WIFI	Band 2 5250~5350MHz Band Edge @ 3m	
ANT	802.11a CH60 5300MHz - L	
1	Vertical	Fundamental
Peak	 <p>Site : 03CH13-HY Condition : PEAK_BE_74 3m HORN_91200_1241 VERTICAL RBW:1000.000KHz VBW:3000.000KHz SWT:Auto Detector : Peak Project : 671336-04 Mode : 2 Power : 15</p>	 <p>Site : 03CH13-HY Condition : PEAK_74 3m HORN_91200_1241 VERTICAL RBW:1000.000KHz VBW:3000.000KHz SWT:Auto Detector : Peak Project : 671336-04 Mode : 2 Power : 15</p>
Avg.	 <p>Site : 03CH13-HY Condition : AVG_BE_54 3m HORN_91200_1241 VERTICAL RBW:1000.000KHz VBW:3000.000KHz SWT:Auto Detector : Peak Project : 671336-04 Mode : 2 Power : 15</p>	Left blank

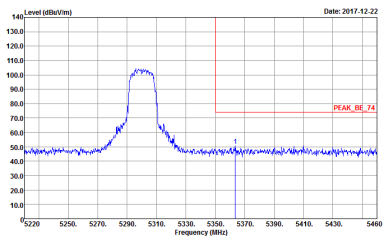
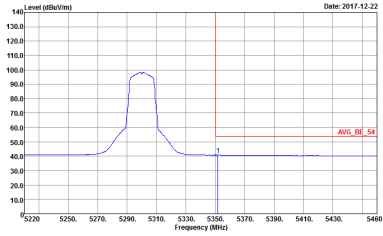

WIFI	Band 2 5250~5350MHz Band Edge @ 3m	
ANT	802.11a CH60 5300MHz - R	
1	Vertical	Fundamental
<p>Peak</p>	 <p>Site : 03CH13-HY Condition : PEAK_BE_74 3m HORN_91200_1241 VERTICAL : RBW:1000.000KHz VBW:3000.000KHz SWT:Auto Detector : Peak Project : 671336-04 Mode : 2 Power : 15</p>	<p>Left blank</p>
<p>Avg.</p>	 <p>Site : 03CH13-HY Condition : AVG_BE_54 3m HORN_91200_1241 VERTICAL : RBW:1000.000KHz VBW:3000.000KHz SWT:Auto Detector : Peak Project : 671336-04 Mode : 2 Power : 15</p>	<p>Left blank</p>

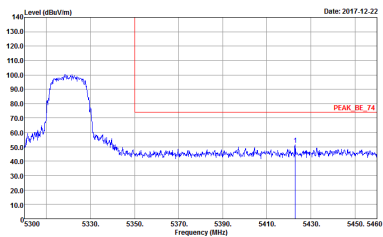
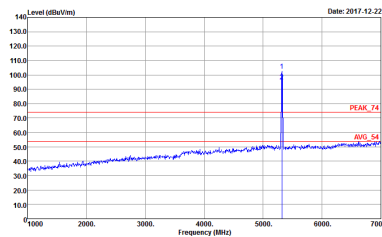
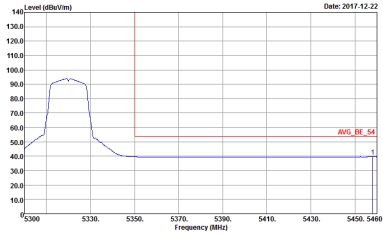

WIFI	Band 2 5250~5350MHz Band Edge @ 3m	
ANT	802.11a CH64 5320MHz	
1	Horizontal	Fundamental
Peak	 <p>Date: 2017.12.22</p> <p>Site : 03CH13-HY Condition : PEAK_BE_74 3m HORN_91200_1241 HORIZONTAL RBW:1000.000KHz VBW:3000.000KHz SWT:Auto Detector : Peak Project : 671336-04 Mode : 3 Power : 15</p>	 <p>Date: 2017.12.22</p> <p>Site : 03CH13-HY Condition : PEAK_74 3m HORN_91200_1241 HORIZONTAL RBW:1000.000KHz VBW:3000.000KHz SWT:Auto Detector : Peak Project : 671336-04 Mode : 3 Power : 15</p>
Avg.	 <p>Date: 2017.12.22</p> <p>Site : 03CH13-HY Condition : AVG_BE_54 3m HORN_91200_1241 HORIZONTAL RBW:1000.000KHz VBW:3000.000KHz SWT:Auto Detector : Peak Project : 671336-04 Mode : 3 Power : 15</p>	Left blank

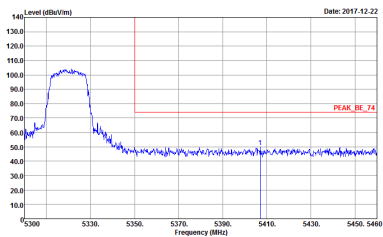
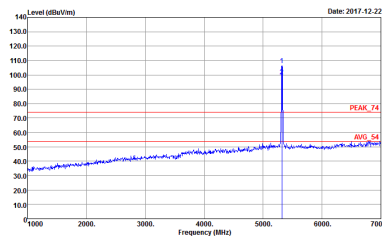
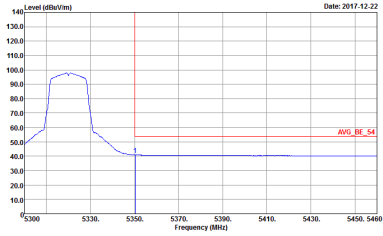

WIFI	Band 2 5250~5350MHz Band Edge @ 3m	
ANT	802.11a CH64 5320MHz	
1	Vertical	Fundamental
Peak	 <p>Date: 2017-12-22</p> <p>Site : 03CH13-HY Condition : PEAK_BE_74 3m HORN_9120D_1241 VERTICAL RBW:1000.000KHz VBW:3000.000KHz SWT:Auto Detector : Peak Project : 671336-04 Mode : 3 Power : 15</p>	 <p>Date: 2017-12-22</p> <p>Site : 03CH13-HY Condition : PEAK_74 3m HORN_9120D_1241 VERTICAL RBW:1000.000KHz VBW:3000.000KHz SWT:Auto Detector : Peak Project : 671336-04 Mode : 3 Power : 15</p>
Avg.	 <p>Date: 2017-12-22</p> <p>Site : 03CH13-HY Condition : AVG_BE_54 3m HORN_9120D_1241 VERTICAL RBW:1000.000KHz VBW:3000.000KHz SWT:Auto Detector : Peak Project : 671336-04 Mode : 3 Power : 15</p>	Left blank



Band 2 5250~5350MHz
WIFI 802.11n HT20 (Band Edge @ 3m)

WIFI	Band 2 5250~5350MHz Band Edge @ 3m	
ANT	802.11n HT20 CH52 5260MHz - L	
1	Horizontal	Fundamental
Peak	<p>Site : 03CH13-1HY Condition : PEAK_BE_74 3m HORN_91200_1241 HORIZONTAL RBW:1000.000KHz VBW:3000.000KHz SWT:Auto Detector : Peak Project : 671336-04 Mode : 4 Power : 15</p>	<p>Site : 03CH13-1HY Condition : PEAK_74 3m HORN_91200_1241 HORIZONTAL RBW:1000.000KHz VBW:3000.000KHz SWT:Auto Detector : Peak Project : 671336-04 Mode : 4 Power : 15</p>
Avg.	<p>Site : 03CH13-1HY Condition : AVG_BE_54 3m HORN_91200_1241 HORIZONTAL RBW:1000.000KHz VBW:0.010KHz SWT:Auto Detector : Peak Project : 671336-04 Mode : 4 Power : 15</p>	Left blank

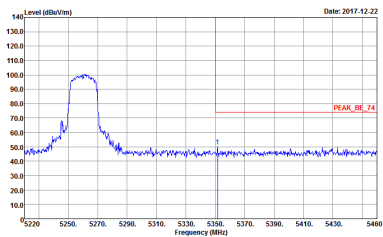
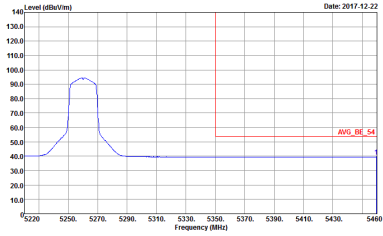

WIFI	Band 2 5250~5350MHz Band Edge @ 3m	
ANT	802.11n HT20 CH52 5260MHz - R	
1	Horizontal	Fundamental
<p>Peak</p>	 <p>Site : 03CH13-HY Condition : PEAK_BE_74 3m HORN_91200_1241 HORIZONTAL Detector : Peak Project : 671336-04 Mode : 4 Power : 15</p>	<p>Left blank</p>
<p>Avg.</p>	 <p>Site : 03CH13-HY Condition : AVG_BE_54 3m HORN_91200_1241 HORIZONTAL Detector : Peak Project : 671336-04 Mode : 4 Power : 15</p>	<p>Left blank</p>



WIFI	Band 2 5250~5350MHz Band Edge @ 3m	
ANT	802.11n HT20 CH52 5260MHz - L	
1	Vertical	Fundamental
Peak	<p>Site : 03CH13-HY Condition : PEAK_BE_74 3m HORN_9120D_1241 VERTICAL : RBW:1000.000KHz VBW:3000.000KHz SWT:Auto Detector : Peak Project : 671336-04 Mode : 4 Power : 15</p>	<p>Site : 03CH13-HY Condition : PEAK_74 3m HORN_9120D_1241 VERTICAL : RBW:1000.000KHz VBW:3000.000KHz SWT:Auto Detector : Peak Project : 671336-04 Mode : 4 Power : 15</p>
Avg.	<p>Site : 03CH13-HY Condition : AVG_BE_54 3m HORN_9120D_1241 VERTICAL : RBW:1000.000KHz VBW:3000.000KHz SWT:Auto Detector : Peak Project : 671336-04 Mode : 4 Power : 15</p>	Left blank



WIFI	Band 2 5250~5350MHz Band Edge @ 3m	
ANT	802.11n HT20 CH52 5260MHz - R	
1	Vertical	Fundamental
<p>Peak</p>		<p>Left blank</p>
<p>Avg.</p>		<p>Left blank</p>

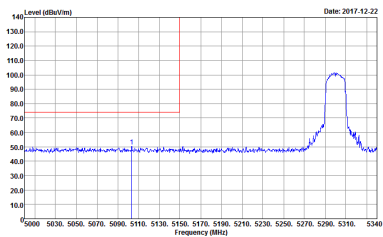
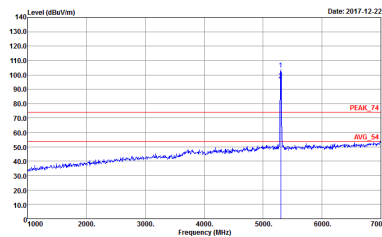
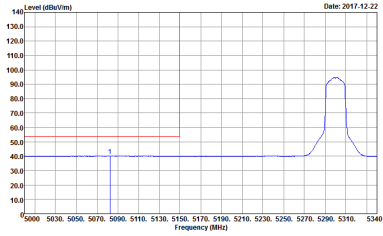

WIFI	Band 2 5250~5350MHz Band Edge @ 3m	
ANT	802.11n HT20 CH60 5300MHz - L	
1	Horizontal	Fundamental
Peak	 <p>Date: 2017-12-22</p> <p>Site : 03CH13-HY Condition : PEAK_BE_74 3m HORN_9120D_1241 HORIZONTAL RBW:1000.000KHz VBW:3000.000KHz SWT:Auto Detector : Peak Project : 671336-04 Mode : 5 Power : 15</p>	 <p>Date: 2017-12-22</p> <p>Site : 03CH13-HY Condition : PEAK_74 3m HORN_9120D_1241 HORIZONTAL RBW:1000.000KHz VBW:3000.000KHz SWT:Auto Detector : Peak Project : 671336-04 Mode : 5 Power : 15</p>
Avg.	 <p>Date: 2017-12-22</p> <p>Site : 03CH13-HY Condition : AVG_BE_54 3m HORN_9120D_1241 HORIZONTAL RBW:1000.000KHz VBW:3000.000KHz SWT:Auto Detector : Peak Project : 671336-04 Mode : 5 Power : 15</p>	Left blank

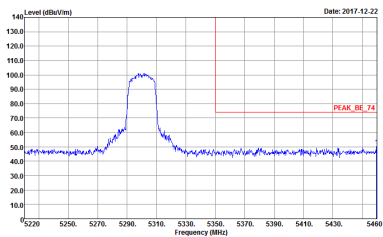
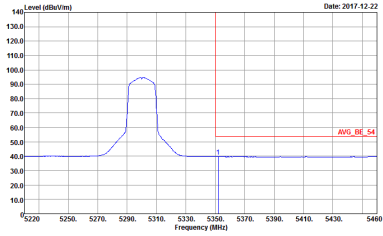

WIFI	Band 2 5250~5350MHz Band Edge @ 3m	
ANT	802.11n HT20 CH60 5300MHz - R	
1	Horizontal	Vertical
<p>Peak</p>	 <p>Site : 03CH13-HY Condition : PEAK_BE_74 3m HORN_91200_1241 HORIZONTAL : RBW:1000.000KHz VBW:3000.000KHz SWT:Auto Detector : Peak Project : 671336-04 Mode : 5 Power : 15</p>	<p>Left blank</p>
<p>Avg.</p>	 <p>Site : 03CH13-HY Condition : AVG_BE_54 3m HORN_91200_1241 HORIZONTAL : RBW:1000.000KHz VBW:3000.000KHz SWT:Auto Detector : Peak Project : 671336-04 Mode : 5 Power : 15</p>	<p>Left blank</p>

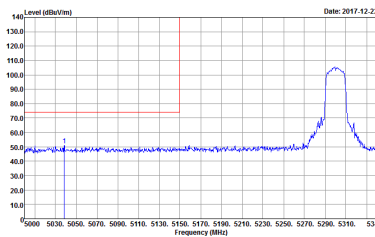
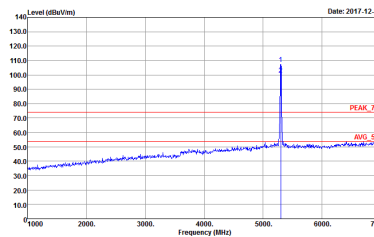
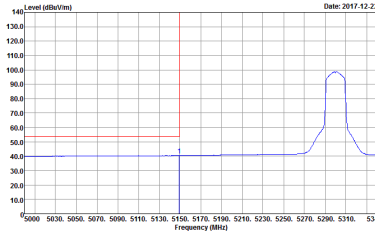

WIFI	Band 2 5250~5350MHz Band Edge @ 3m	
ANT	802.11n HT20 CH60 5300MHz - L	
1	Vertical	Fundamental
Peak	 <p>Date: 2017-12-22</p> <p>Site : 03CH13-HY Condition : PEAK_BE_74 3m HORN_9120D_1241 VERTICAL : RBW:1000.000KHz VBW:3000.000KHz SWT:Auto Detector : Peak Project : 671336-04 Mode : 5 Power : 15</p>	 <p>Date: 2017-12-22</p> <p>Site : 03CH13-HY Condition : PEAK_74 3m HORN_9120D_1241 VERTICAL : RBW:1000.000KHz VBW:3000.000KHz SWT:Auto Detector : Peak Project : 671336-04 Mode : 5 Power : 15</p>
Avg.	 <p>Date: 2017-12-22</p> <p>Site : 03CH13-HY Condition : AVG_BE_54 3m HORN_9120D_1241 VERTICAL : RBW:1000.000KHz VBW:3000.000KHz SWT:Auto Detector : Peak Project : 671336-04 Mode : 5 Power : 15</p>	Left blank

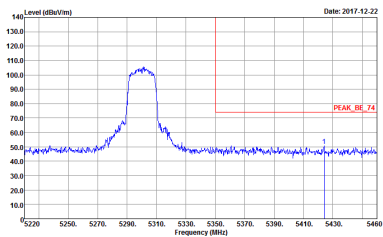
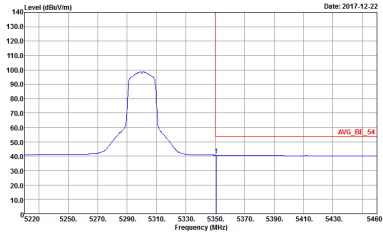

WIFI	Band 2 5250~5350MHz Band Edge @ 3m	
ANT	802.11n HT20 CH60 5300MHz - R	
1	Vertical	Fundamental
<p>Peak</p>	 <p>Site : 03CH13-HY Condition : PEAK_BE_74 3m HORN_91200_1241 VERTICAL : RBW:1000.000KHz VBW:3000.000KHz SWT:Auto Detector : Peak Project : 671336-04 Mode : 5 Power : 15</p>	<p>Left blank</p>
<p>Avg.</p>	 <p>Site : 03CH13-HY Condition : AVG_BE_54 3m HORN_91200_1241 VERTICAL : RBW:1000.000KHz VBW:3000.000KHz SWT:Auto Detector : Peak Project : 671336-04 Mode : 5 Power : 15</p>	<p>Left blank</p>

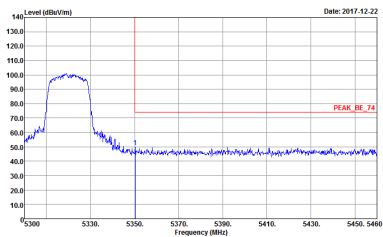
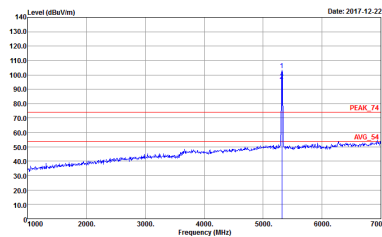
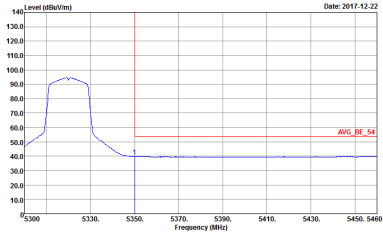

WIFI	Band 2 5250~5350MHz Band Edge @ 3m	
ANT	802.11n HT20 CH64 5320MHz	
1	Horizontal	Fundamental
Peak	 <p>Date: 2017-12-22</p> <p>Site : 03CH13-HY Condition : PEAK_BE_74 3m HORN_91200_1241 HORIZONTAL : RBW:1000.000KHz VBW:3000.000KHz SWT:Auto Detector : Peak Project : 671336-04 Mode : 6 Power : 15</p>	 <p>Date: 2017-12-22</p> <p>Site : 03CH13-HY Condition : PEAK_74 3m HORN_91200_1241 HORIZONTAL : RBW:1000.000KHz VBW:3000.000KHz SWT:Auto Detector : Peak Project : 671336-04 Mode : 6 Power : 15</p>
Avg.	 <p>Date: 2017-12-22</p> <p>Site : 03CH13-HY Condition : AVG_BE_54 3m HORN_91200_1241 HORIZONTAL : RBW:1000.000KHz VBW:3000.000KHz SWT:Auto Detector : Peak Project : 671336-04 Mode : 6 Power : 15</p>	Left blank



WIFI	Band 2 5250~5350MHz Band Edge @ 3m	
ANT	802.11n HT20 CH64 5320MHz	
1	Vertical	Fundamental
Peak	<p>Site : 03CH13-HY Condition : PEAK_BE_74 3m HORN_9120D_1241 VERTICAL : RBW:1000.000KHz VBW:3000.000KHz SWT:Auto Detector : Peak Project : 671336-04 Mode : 6 Power : 15</p>	<p>Site : 03CH13-HY Condition : PEAK_74 3m HORN_9120D_1241 VERTICAL : RBW:1000.000KHz VBW:3000.000KHz SWT:Auto Detector : Peak Project : 671336-04 Mode : 6 Power : 15</p>
Avg.	<p>Site : 03CH13-HY Condition : AVG_BE_54 3m HORN_9120D_1241 VERTICAL : RBW:1000.000KHz VBW:3000.000KHz SWT:Auto Detector : Peak Project : 671336-04 Mode : 6 Power : 15</p>	Left blank



Band 2 5250~5350MHz
WIFI 802.11n HT40 (Band Edge @ 3m)

WIFI	Band 2 5250~5350MHz Band Edge @ 3m	
ANT	802.11n HT40 CH54 5270 - L	
1	Horizontal	Fundamental
Peak	<p>Site : 03CH13-HY Condition : PEAK_BE_74 3m HORN_91200_1241 HORIZONTAL RBW:1000.000KHz VBW:3000.000KHz SWT:Auto Detector : Peak Project : 671336-04 Mode : 7 Power : 15</p>	<p>Site : 03CH13-HY Condition : PEAK_74 3m HORN_91200_1241 HORIZONTAL RBW:1000.000KHz VBW:3000.000KHz SWT:Auto Detector : Peak Project : 671336-04 Mode : 7 Power : 15</p>
Avg.	<p>Site : 03CH13-HY Condition : AVG_BE_54 3m HORN_91200_1241 HORIZONTAL RBW:1000.000KHz VBW:0.010KHz SWT:Auto Detector : Peak Project : 671336-04 Mode : 7 Power : 15</p>	Left blank

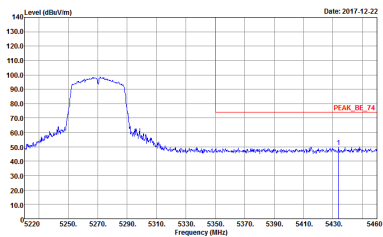
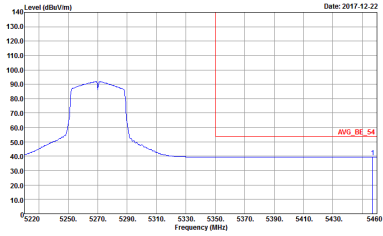

WIFI	Band 2 5250~5350MHz Band Edge @ 3m	
ANT	802.11n HT40 CH54 5270 - R	
1	Horizontal	Fundamental
<p>Peak</p>	 <p>Site : 03CH13-HY Condition : PEAK_BE_74 3m HORN_9120D_1241 HORIZONTAL : RBW:1000.000KHz VBW:3000.000KHz SWT:Auto Detector : Peak Project : 671336-04 Mode : 7 Power : 15</p>	<p>Left blank</p>
<p>Avg.</p>	 <p>Site : 03CH13-HY Condition : AVG_BE_54 3m HORN_9120D_1241 HORIZONTAL : RBW:1000.000KHz VBW:3000.000KHz SWT:Auto Detector : Peak Project : 671336-04 Mode : 7 Power : 15</p>	<p>Left blank</p>



WIFI	Band 2 5250~5350MHz Band Edge @ 3m	
ANT	802.11n HT40 CH54 5270 - L	
1	Vertical	Vertical
Peak	<p>Site : 03CH13-HY Condition : PEAK_BE_74 3m HORN_9120D_1241 VERTICAL Detector : Peak Project : 671336-04 Mode : 7 Power : 15</p>	<p>Site : 03CH13-HY Condition : PEAK_74 3m HORN_9120D_1241 VERTICAL Detector : Peak Project : 671336-04 Mode : 7 Power : 15</p>
Avg.	<p>Site : 03CH13-HY Condition : AVG_BE_54 3m HORN_9120D_1241 VERTICAL Detector : Peak Project : 671336-04 Mode : 7 Power : 15</p>	Left blank

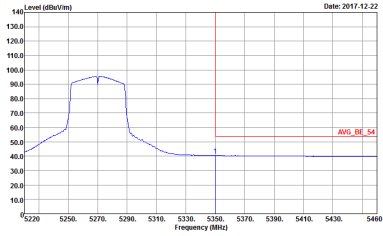

WIFI	Band 2 5250~5350MHz Band Edge @ 3m	
ANT	802.11n HT40 CH54 5270 - R	
1	Vertical	Vertical
Peak	 <p>Site : 03CH13-HY Condition : PEAK_BE_74 3m HORN_9120D_1241 VERTICAL : RBW:1000.000KHz VBW:3000.000KHz SWT:Auto Detector : Peak Project : 671336-04 Mode : 7 Power : 15</p>	Left blank
Avg.	 <p>Site : 03CH13-HY Condition : AVG_BE_54 3m HORN_9120D_1241 VERTICAL : RBW:1000.000KHz VBW:3000.000KHz SWT:Auto Detector : Peak Project : 671336-04 Mode : 7 Power : 15</p>	Left blank

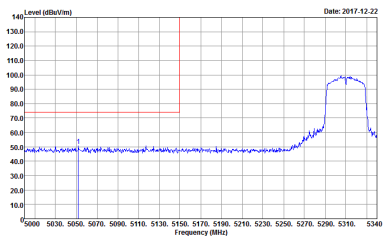
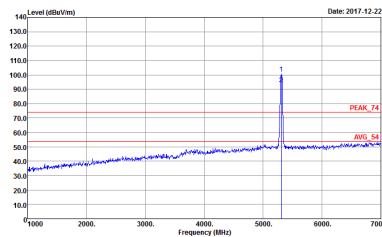
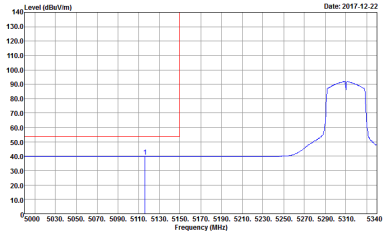

WIFI	Band 2 5250~5350MHz Band Edge @ 3m	
ANT	802.11n HT40 CH62 5310 - L	
1	Horizontal	Fundamental
Peak	 <p>Date: 2017-12-22</p> <p>Site : 03CH13-HY Condition : PEAK_BE_74 3m HORN_9120D_1241 HORIZONTAL RBW:1000.000KHz VBW:3000.000KHz SWT:Auto Detector : Peak Project : 671336-04 Mode : 8 Power : 15</p>	 <p>Date: 2017-12-22</p> <p>Site : 03CH13-HY Condition : PEAK_74 3m HORN_9120D_1241 HORIZONTAL RBW:1000.000KHz VBW:3000.000KHz SWT:Auto Detector : Peak Project : 671336-04 Mode : 8 Power : 15</p>
Avg.	 <p>Date: 2017-12-22</p> <p>Site : 03CH13-HY Condition : AVG_BE_54 3m HORN_9120D_1241 HORIZONTAL RBW:1000.000KHz VBW:3000.000KHz SWT:Auto Detector : Peak Project : 671336-04 Mode : 8 Power : 15</p>	Left blank

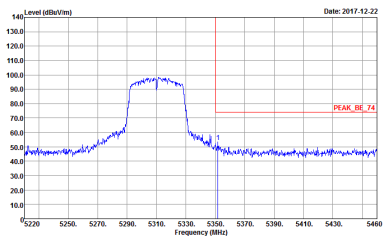
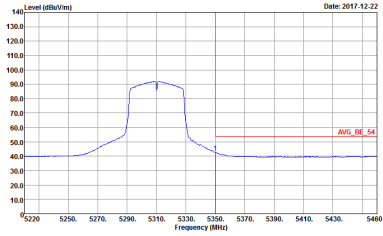

WIFI	Band 2 5250~5350MHz Band Edge @ 3m	
ANT	802.11n HT40 CH62 5310 - R	
1	Horizontal	Fundamental
<p>Peak</p>	 <p>Site : 03CH13-HY Condition : PEAK_BE_74 3m HORN_91200_1241 HORIZONTAL : RBW:1000.000KHz VBW:3000.000KHz SWT:Auto Detector : Peak Project : 671336-04 Mode : B Power : 15</p>	<p>Left blank</p>
<p>Avg.</p>	 <p>Site : 03CH13-HY Condition : AVG_BE_54 3m HORN_91200_1241 HORIZONTAL : RBW:1000.000KHz VBW:3000.000KHz SWT:Auto Detector : Peak Project : 671336-04 Mode : B Power : 15</p>	<p>Left blank</p>

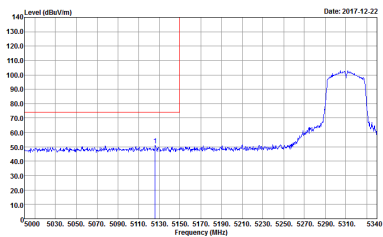
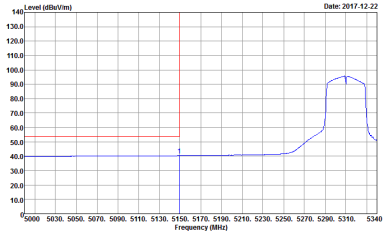

WIFI	Band 2 5250~5350MHz Band Edge @ 3m	
ANT	802.11n HT40 CH62 5310 - L	
1	Vertical	Fundamental
Peak	 <p>Site : 03CH13-HY Condition : PEAK_BE_74 3m HORN_9120D_1241 VERTICAL : RBW:1000.000KHz VBW:3000.000KHz SWT:Auto Detector : Peak Project : 671336-04 Mode : 8 Power : 15</p>	 <p>Site : 03CH13-HY Condition : PEAK_74 3m HORN_9120D_1241 VERTICAL : RBW:1000.000KHz VBW:3000.000KHz SWT:Auto Detector : Peak Project : 671336-04 Mode : 8 Power : 15</p>
Avg.	 <p>Site : 03CH13-HY Condition : AVG_BE_54 3m HORN_9120D_1241 VERTICAL : RBW:1000.000KHz VBW:3000.000KHz SWT:Auto Detector : Peak Project : 671336-04 Mode : 8 Power : 15</p>	Left blank

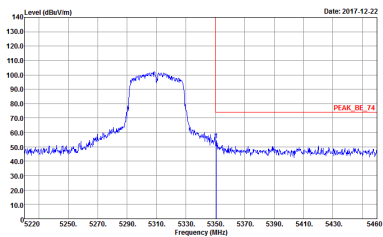
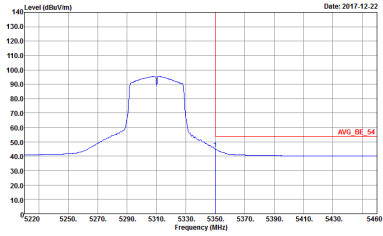

WIFI	Band 2 5250~5350MHz Band Edge @ 3m	
ANT	802.11n HT40 CH62 5310 - R	
1	Vertical	Fundamental
<p>Peak</p>	 <p>Site : 03CH13-HY Condition : PEAK_BE_74 3m HORN_9120D_1241 VERTICAL : RBW:1000.000KHz VBW:3000.000KHz SWT:Auto Detector : Peak Project : 671336-04 Mode : B Power : 15</p>	<p>Left blank</p>
<p>Avg.</p>	 <p>Site : 03CH13-HY Condition : AVG_BE_54 3m HORN_9120D_1241 VERTICAL : RBW:1000.000KHz VBW:3000.000KHz SWT:Auto Detector : Peak Project : 671336-04 Mode : B Power : 15</p>	<p>Left blank</p>



Band 2 5250~5350MHz
WIFI 802.11ac VHT80 (Band Edge @ 3m)

WIFI	Band 2 5250~5350MHz Band Edge @ 3m	
ANT	802.11ac VHT80 CH58 5290MHz - L	
1	Horizontal	Fundamental
Peak	<p>Site : 03CH13-HY Condition : PEAK_BE_74 3m HORN_91200_1241 HORIZONTAL RBW:1000.000KHz VBW:3000.000KHz SWT:Auto Detector : Peak Project : 671336-04 Mode : 9 Power : 14</p>	<p>Site : 03CH13-HY Condition : PEAK_74 3m HORN_91200_1241 HORIZONTAL RBW:1000.000KHz VBW:3000.000KHz SWT:Auto Detector : Peak Project : 671336-04 Mode : 9 Power : 14</p>
Avg.	<p>Site : 03CH13-HY Condition : AVG_BE_54 3m HORN_91200_1241 HORIZONTAL RBW:1000.000KHz VBW:0.010KHz SWT:Auto Detector : Peak Project : 671336-04 Mode : 9 Power : 14</p>	Left blank

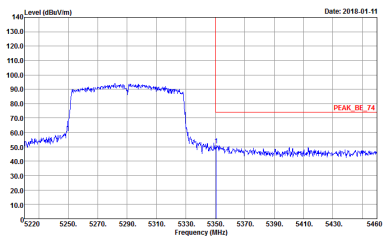
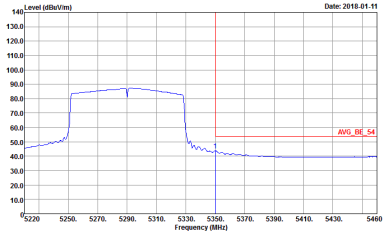

WIFI	Band 2 5250~5350MHz Band Edge @ 3m	
ANT	802.11ac VHT80 CH58 5290MHz - R	
1	Horizontal	Fundamental
<p>Peak</p>	 <p>Site : 03CH13-HY Condition : PEAK_BE_74 3m HORN_91200_1241 HORIZONTAL : RBW:1000.000KHz VBW:3000.000KHz SWT:Auto Detector : Peak Project : 671336-04 Mode : 9 Power : 14</p>	<p>Left blank</p>
<p>Avg.</p>	 <p>Site : 03CH13-HY Condition : AVG_BE_54 3m HORN_91200_1241 HORIZONTAL : RBW:1000.000KHz VBW:3000.000KHz SWT:Auto Detector : Peak Project : 671336-04 Mode : 9 Power : 14</p>	<p>Left blank</p>



WIFI	Band 2 5250~5350MHz Band Edge @ 3m	
ANT	802.11ac VHT80 CH58 5290MHz - L	
1	Vertical	Fundamental
Peak	<p>Date: 2018-01-11</p> <p>Site : 03CH13-HY Condition : PEAK_BE_74 3m HORN_91200_1241 VERTICAL : RBW:1000.000KHz VBW:3000.000KHz SWT:Auto Detector : Peak Project : 671336-04 Mode : 9 Power : 14</p>	<p>Date: 2018-01-11</p> <p>Site : 03CH13-HY Condition : PEAK_74 3m HORN_91200_1241 VERTICAL : RBW:1000.000KHz VBW:3000.000KHz SWT:Auto Detector : Peak Project : 671336-04 Mode : 9 Power : 14</p>
Avg.	<p>Date: 2018-01-11</p> <p>Site : 03CH13-HY Condition : AVG_BE_54 3m HORN_91200_1241 VERTICAL : RBW:1000.000KHz VBW:3000.000KHz SWT:Auto Detector : Peak Project : 671336-04 Mode : 9 Power : 14</p>	Left blank



WIFI	Band 2 5250~5350MHz Band Edge @ 3m	
ANT	802.11ac VHT80 CH58 5290MHz - R	
1	Vertical	Fundamental
Peak	<p>Site : 03CH13-HY Condition : PEAK_BE_74 3m HORN_9120D_1241 VERTICAL : RBW:1000.000KHz VBW:3000.000KHz SWT:Auto Detector : Peak Project : 671336-04 Mode : 9 Power : 14</p>	Left blank
Avg.	<p>Site : 03CH13-HY Condition : AVG_BE_54 3m HORN_9120D_1241 VERTICAL : RBW:1000.000KHz VBW:3000.000KHz SWT:Auto Detector : Peak Project : 671336-04 Mode : 9 Power : 14</p>	Left blank



**Band 2 - 5250~5350MHz
WIFI 802.11a (Harmonic @ 3m)**

WIFI	Band 2 5250~5350MHz Harmonic @ 3m	
ANT	802.11a CH52 5260MHz	
1	Horizontal	Vertical
<p>Peak</p> <p>Avg.</p>	<p>Site : 03CH13-11Y Condition : PEAK(LINE1) 3m SHF_HORN_576 HORIZONTAL Detector : Peak Project : 671336-04 Mode : 1 Power : 15</p>	<p>Site : 03CH13-11Y Condition : PEAK(LINE1) 3m SHF_HORN_576 VERTICAL Detector : Peak Project : 671336-04 Mode : 1 Power : 15</p>

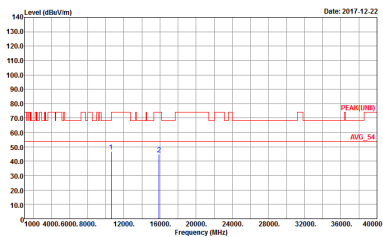
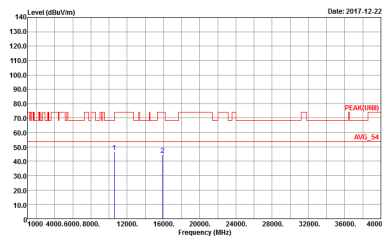

WIFI	Band 2 5250~5350MHz Harmonic @ 3m	
ANT	802.11a CH60 5300MHz	
1	Horizontal	Vertical
<p>Peak</p> <p>Avg.</p>	 <p>Site : 03CHE2-11Y Condition : PEAK(LINE) 3m SHF_HORN_576 HORIZONTAL Detector : Peak Project : 671336-04 Mode : 2 Power : 15</p>	 <p>Site : 03CHE2-11Y Condition : PEAK(LINE) 3m SHF_HORN_576 VERTICAL Detector : Peak Project : 671336-04 Mode : 2 Power : 15</p>

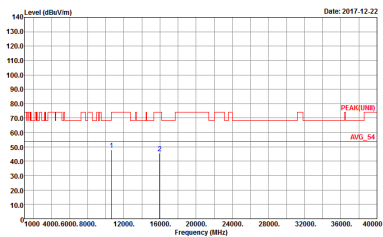
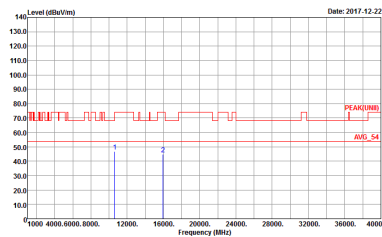

WIFI	Band 2 5250~5350MHz Harmonic @ 3m	
ANT	802.11a CH64 5320MHz	
1	Horizontal	Vertical
<p>Peak</p> <p>Avg.</p>	 <p>Site : 03CHE2-11Y Condition : PEAK(LINE1) 3m SHF_HORN_576 HORIZONTAL Detector : Peak Project : 671336-04 Mode : S Power : 15</p>	 <p>Site : 03CHE2-11Y Condition : PEAK(LINE1) 3m SHF_HORN_576 VERTICAL Detector : Peak Project : 671336-04 Mode : S Power : 15</p>



Band 2 5250~5350MHz
WIFI 802.11n HT20 (Harmonic @ 3m)

WIFI	Band 2 5250~5350MHz Harmonic @ 3m	
ANT	802.11n HT20 CH52 5260MHz	
1	Horizontal	Vertical
<p>Peak</p> <p>Avg.</p>	<p>Site : 03CH13-HY Condition : PEAK(UNIT) 3m SHF_HORN_576 HORIZONTAL Detector : Peak Project : 671336-04 Mode : 4 Power : 15</p>	<p>Site : 03CH13-HY Condition : PEAK(UNIT) 3m SHF_HORN_576 VERTICAL Detector : Peak Project : 671336-04 Mode : 4 Power : 15</p>

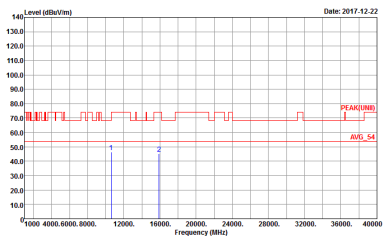
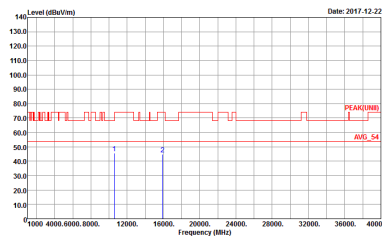

WIFI	Band 2 5250~5350MHz Harmonic @ 3m	
ANT	802.11n HT20 CH60 5300MHz	
1	Horizontal	Vertical
<p>Peak</p> <p>Avg.</p>	 <p>Site : 03CHE2-11Y Condition : PEAK(LINE) 3m SHF_HORN_576 HORIZONTAL Detector : Peak Project : 671336-04 Mode : S Power : 15</p>	 <p>Site : 03CHE2-11Y Condition : PEAK(LINE) 3m SHF_HORN_576 VERTICAL Detector : Peak Project : 671336-04 Mode : S Power : 15</p>

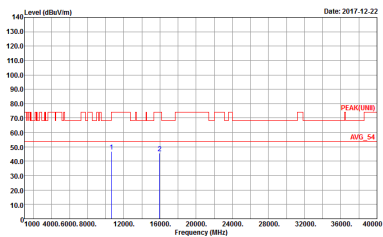
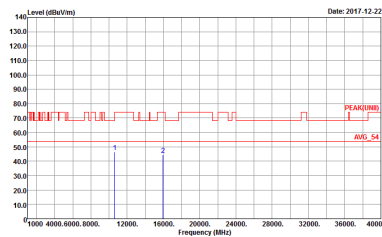

WIFI	Band 2 5250~5350MHz Harmonic @ 3m	
ANT	802.11n HT20 CH64 5320MHz	
1	Horizontal	Vertical
<p>Peak</p> <p>Avg.</p>	 <p>Site : 03CHE2-11Y Condition : PEAK(LINE) 3m SHF_HORN_576 HORIZONTAL Detector : Peak Project : 671336-04 Mode : 6 Power : 15</p>	 <p>Site : 03CHE2-11Y Condition : PEAK(LINE) 3m SHF_HORN_576 VERTICAL Detector : Peak Project : 671336-04 Mode : 6 Power : 15</p>



Band 2 5250~5350MHz
WIFI 802.11n HT40 (Harmonic @ 3m)

WIFI	Band 2 5250~5350MHz Harmonic @ 3m	
ANT	802.11n HT40 CH54 5270MHz	
1	Horizontal	Vertical
<p>Peak</p> <p>Avg.</p>	<p>Site : 03CH13-HY Condition : PEAK(UNIT) 3m SHF_HORN_576 HORIZONTAL Detector : Peak Project : 671336-04 Mode : 7 Power : 15</p>	<p>Site : 03CH13-HY Condition : PEAK(UNIT) 3m SHF_HORN_576 VERTICAL Detector : Peak Project : 671336-04 Mode : 7 Power : 15</p>

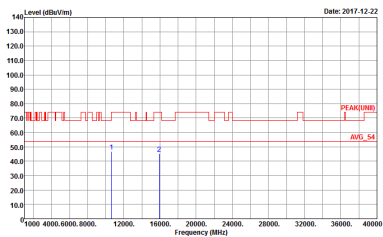
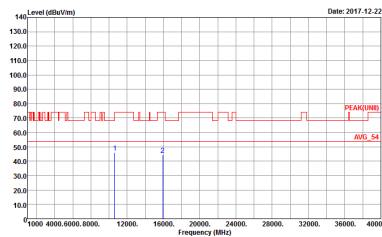

WIFI	Band 2 5250~5350MHz Harmonic @ 3m	
ANT	802.11n HT40 CH62 5310MHz	
1	Horizontal	Vertical
<p>Peak</p> <p>Avg.</p>	 <p>Site : 03CHE2-11Y Condition : PEAK(LINE) 3m SHF_HORN_576 HORIZONTAL Detector : Peak Project : 671336-04 Mode : S Power : 15</p>	 <p>Site : 03CHE2-11Y Condition : PEAK(LINE) 3m SHF_HORN_576 VERTICAL Detector : Peak Project : 671336-04 Mode : S Power : 15</p>



Band 2 5250~5350MHz
WIFI 802.11ac VHT80 (Harmonic @ 3m)

WIFI	Band 2 5250~5350MHz Harmonic @ 3m	
ANT	802.11ac VHT80 CH58 5290MHz	
1	Horizontal	Vertical
Peak Avg.	<p>Site : 03CH13-HY Condition : PEAK(UNIT) 3m SHF_HORN_576 HORIZONTAL Detector : Peak Project : 671336-04 Mode : 9 Power : 14</p>	<p>Site : 03CH13-HY Condition : PEAK(UNIT) 3m SHF_HORN_576 VERTICAL Detector : Peak Project : 671336-04 Mode : 9 Power : 14</p>



Band 3 - 5470~5725MHz
WIFI 802.11a (Band Edge @ 3m)

WIFI	Band 3 5470~5725MHz Band Edge @ 3m	
ANT	802.11a CH100 5500MHz	
1	Horizontal	Fundamental
Peak	<p>Site : 03CH13-HY Condition : PEAK_BE(UNIT), B3 3m HORN, 91200, 1241 HORIZONTAL RBW:1000.000KHz VBW:3000.000KHz SWT:Auto Detector : Peak Project : 671336-04 Mode : 10 Power : 14</p>	<p>Site : 03CH13-HY Condition : PEAK(UNIT) 3m HORN, 91200, 1241 HORIZONTAL RBW:1000.000KHz VBW:3000.000KHz SWT:Auto Detector : Peak Project : 671336-04 Mode : 10 Power : 14</p>
Avg.	<p>Site : 03CH13-HY Condition : AVG_BE(UNIT), B3 3m HORN, 91200, 1241 HORIZONTAL RBW:1000.000KHz VBW:3000.000KHz SWT:Auto Detector : Peak Project : 671336-04 Mode : 10 Power : 14</p>	Left blank



WIFI	Band 3 5470~5725MHz Band Edge @ 3m	
ANT	802.11a CH100 5500MHz	
1	Vertical	Fundamental
Peak	<p>Site : 03CH13-HY Condition : PEAK_BE(UNIT), B3 3m HORN_91200_1241 VERTICAL : RBW:1000.000KHz VBW:3000.000KHz SWT:Auto Detector : Peak Project : 671336-04 Mode : 10 Power : 14</p>	<p>Site : 03CH13-HY Condition : PEAK(UNIT) 3m HORN_91200_1241 VERTICAL : RBW:1000.000KHz VBW:3000.000KHz SWT:Auto Detector : Peak Project : 671336-04 Mode : 10 Power : 14</p>
Avg.	<p>Site : 03CH13-HY Condition : AVG_BE(UNIT), B3 3m HORN_91200_1241 VERTICAL : RBW:1000.000KHz VBW:0.010KHz SWT:Auto Detector : Peak Project : 671336-04 Mode : 10 Power : 14</p>	Left blank



WIFI	Band 3 5470~5725MHz Band Edge @ 3m	
ANT	802.11a CH16 5580MHz - L	
1	Horizontal	Fundamental
Peak	<p>Site : 03CH13-HY Condition : PEAK_BE(UNIT), B3 3m HORN_91200_1241 HORIZONTAL : RBW:1000.000KHz VBW:3000.000KHz SWT:Auto Detector : Peak Project : 671336-04 Mode : 11 Power : 14</p>	<p>Site : 03CH13-HY Condition : PEAK(UNIT) 3m HORN_91200_1241 HORIZONTAL : RBW:1000.000KHz VBW:3000.000KHz SWT:Auto Detector : Peak Project : 671336-04 Mode : 11 Power : 14</p>
Avg.	<p>Site : 03CH13-HY Condition : AVG_BE(UNIT), B3 3m HORN_91200_1241 HORIZONTAL : RBW:1000.000KHz VBW:3000.000KHz SWT:Auto Detector : Peak Project : 671336-04 Mode : 11 Power : 14</p>	Left blank



WIFI	Band 3 5470~5725MHz Band Edge @ 3m	
ANT	802.11a CH116 5580MHz - R	
1	Horizontal	Fundamental
Peak	<p>Site : D8CH13-4/F Condition : PEAK_BE([UNIT]), B3 3m HORN_91200_1241 HORIZONTAL Detector : Peak Project : 671336-04 Mode : 11 Power : 14</p>	Left blank

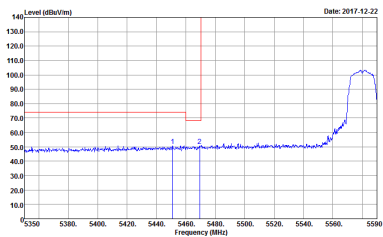
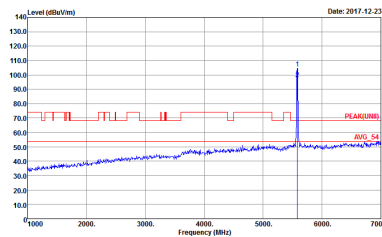
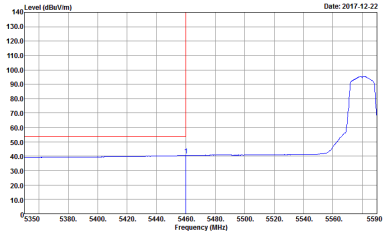

WIFI	Band 3 5470~5725MHz Band Edge @ 3m	
ANT	802.11a CH16 5580MHz - L	
1	Vertical	Fundamental
Peak	 <p>Date: 2017-12-22</p> <p>Site : 03CH13-HY Condition : PEAK_BE(UNIT), B3 3m HORN_91200_1241 VERTICAL : RBW:1000.000KHz VBW:3000.000KHz SWT:Auto Detector : Peak Project : 671336-04 Mode : 11 Power : 14</p>	 <p>Date: 2017-12-23</p> <p>Site : 03CH13-HY Condition : PEAK(UNIT) 3m HORN_91200_1241 VERTICAL : RBW:1000.000KHz VBW:3000.000KHz SWT:Auto Detector : Peak Project : 671336-04 Mode : 11 Power : 14</p>
Avg.	 <p>Date: 2017-12-22</p> <p>Site : 03CH13-HY Condition : AVG_BE(UNIT), B3 3m HORN_91200_1241 VERTICAL : RBW:1000.000KHz VBW:3000.000KHz SWT:Auto Detector : Peak Project : 671336-04 Mode : 11 Power : 14</p>	Left blank



WIFI	Band 3 5470~5725MHz Band Edge @ 3m	
ANT	802.11a CH116 5580MHz - R	
1	Vertical	Fundamental
Peak	<p>Site : D8CH163-4/F Condition : PEAK_REC(UNII)_B3 3m HORN_91200_1241 VERTICAL Detector : Peak Project : 671336-04 Mode : 11 Power : 14</p>	Left blank



WIFI	Band 3 5470~5725MHz Band Edge @ 3m	
ANT	802.11a CH140 5700MHz	
1	Horizontal	Fundamental
Peak	<p>Site : 03CH13-11Y Condition : PEAK_BE[UNII], B3 3m HORN_91200_1241 HORIZONTAL : RBW:1000.000KHz VBW:3000.000KHz SWT:Auto Detector : Peak Project : 671336-04 Mode : 12 Power : 14</p>	<p>Site : 03CH13-11Y Condition : PEAK[UNII] 3m HORN_91200_1241 HORIZONTAL : RBW:1000.000KHz VBW:3000.000KHz SWT:Auto Detector : Peak Project : 671336-04 Mode : 12 Power : 14</p>



WIFI	Band 3 5470~5725MHz Band Edge @ 3m	
ANT	802.11a CH140 5700MHz	
1	Vertical	Fundamental
Peak	<p>Site : 03CH13-11Y Condition : PEAK_BE[UNII], B3 3m HORN_91200_1241 VERTICAL : RBW:1000.000KHz VBW:3000.000KHz SWT:Auto Detector : Peak Project : 671336-04 Mode : 12 Power : 14</p>	<p>Site : 03CH13-11Y Condition : PEAK[UNII] 3m HORN_91200_1241 VERTICAL : RBW:1000.000KHz VBW:3000.000KHz SWT:Auto Detector : Peak Project : 671336-04 Mode : 12 Power : 14</p>



**Band 3 5470~5725MHz
WIFI 802.11n HT20 (Band Edge @ 3m)**

WIFI	Band 3 5470~5725MHz Band Edge @ 3m	
ANT	802.11n HT20 CH100 5500MHz	
1	Horizontal	Fundamental
Peak	<p>Site : 03CH13-HY Condition : PEAK_BE(UNIT1)_B3 3m HORN_9120D_1241 HORIZONTAL Detector : Peak Project : 671336-04 Mode : 13 Power : 15</p>	<p>Site : 03CH13-HY Condition : PEAK(UNIT1) 3m HORN_9120D_1241 HORIZONTAL Detector : Peak Project : 671336-04 Mode : 13 Power : 15</p>
Avg.	<p>Site : 03CH13-HY Condition : AVG_BE(UNIT1)_B3 3m HORN_9120D_1241 HORIZONTAL Detector : Peak Project : 671336-04 Mode : 13 Power : 15</p>	Left blank



WIFI	Band 3 5470~5725MHz Band Edge @ 3m	
ANT	802.11n HT20 CH100 5500MHz	
1	Vertical	Fundamental
Peak	<p>Site : 03CH13-HY Condition : PEAK_BE(UNIT), B3 3m HORN_91200_1241 VERTICAL : RBW:1000.000KHz VBW:3000.000KHz SWT:Auto Detector : Peak Project : 671336-04 Mode : 13 Power : 15</p>	<p>Site : 03CH13-HY Condition : PEAK(UNIT) 3m HORN_91200_1241 VERTICAL : RBW:1000.000KHz VBW:3000.000KHz SWT:Auto Detector : Peak Project : 671336-04 Mode : 13 Power : 15</p>
Avg.	<p>Site : 03CH13-HY Condition : AVG_BE(UNIT), B3 3m HORN_91200_1241 VERTICAL : RBW:1000.000KHz VBW:3000.000KHz SWT:Auto Detector : Peak Project : 671336-04 Mode : 13 Power : 15</p>	Left blank

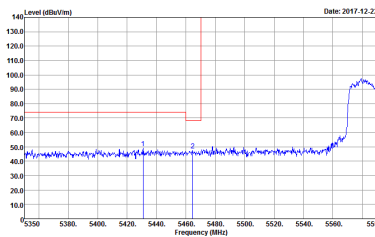
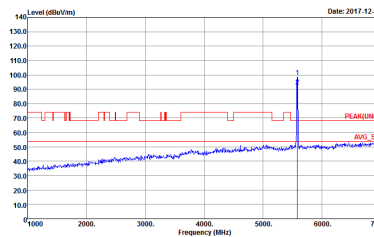
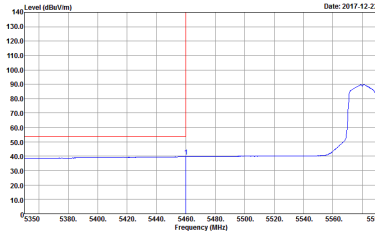

WIFI	Band 3 5470~5725MHz Band Edge @ 3m	
ANT	802.11n HT20 CH116 5580MHz - L	
1	Horizontal	Fundamental
<p>Peak</p>	 <p>Site : 03CH13-HY Condition : PEAK_BE(UNIT)_B3 3m HORN_91200_1241 HORIZONTAL : RBW:1000.000KHz VBW:3000.000KHz SWT:Auto Detector : Peak Project : 671336-04 Mode : 14 Power : 14</p>	 <p>Site : 03CH13-HY Condition : PEAK(UNIT) 3m HORN_91200_1241 HORIZONTAL : RBW:1000.000KHz VBW:3000.000KHz SWT:Auto Detector : Peak Project : 671336-04 Mode : 14 Power : 14</p>
<p>Avg.</p>	 <p>Site : 03CH13-HY Condition : AVG_BE(UNIT)_B3 3m HORN_91200_1241 HORIZONTAL : RBW:1000.000KHz VBW:0.010KHz SWT:Auto Detector : Peak Project : 671336-04 Mode : 14 Power : 14</p>	<p>Left blank</p>



WIFI	Band 3 5470~5725MHz Band Edge @ 3m	
ANT	802.11n HT20 CH116 5580MHz - R	
1	Horizontal	Fundamental
Peak	<p>Site : D8CH13-4/F Condition : PEAK_BE([UNIT]), B3 3m HORN_91200_1241 HORIZONTAL Detector : Peak Project : 672336-04 Mode : 14 Power : 14</p>	Left blank



WIFI	Band 3 5470~5725MHz Band Edge @ 3m	
ANT	802.11n HT20 CH116 5580MHz - L	
1	Vertical	Fundamental
Peak	<p>Site : 03CH13-HY Condition : PEAK_BE(UNIT), B3 3m HORN_91200_1241 VERTICAL : RBW:1000.000KHz VBW:3000.000KHz SWT:Auto Detector : Peak Project : 671336-04 Mode : 14 Power : 14</p>	<p>Site : 03CH13-HY Condition : PEAK(UNIT) 3m HORN_91200_1241 VERTICAL : RBW:1000.000KHz VBW:3000.000KHz SWT:Auto Detector : Peak Project : 671336-04 Mode : 14 Power : 14</p>
Avg.	<p>Site : 03CH13-HY Condition : AVG_BE(UNIT), B3 3m HORN_91200_1241 VERTICAL : RBW:1000.000KHz VBW:3000.000KHz SWT:Auto Detector : Peak Project : 671336-04 Mode : 14 Power : 14</p>	Left blank



WIFI	Band 3 5470~5725MHz Band Edge @ 3m	
ANT	802.11n HT20 CH116 5580MHz - R	
1	Vertical	Fundamental
<p>Peak</p>	<p>Site : D8CH13-4/F Condition : PEAK_BE([UNIT]), B3 3m HORN_91200_1241 VERTICAL Detector : Peak Project : 672336-04 Mode : 14 Power : 14</p>	<p>Left blank</p>



WIFI	Band 3 5470~5725MHz Band Edge @ 3m	
ANT	802.11n HT20 CH140 5700MHz	
1	Horizontal	Fundamental
<p>Peak</p>	<p>Date: 2017-12-22</p> <p>Site : 03CH13-11Y Condition : PEAK_BE[UNII], B3 3m HORN_91200_1241 HORIZONTAL RBW:1000.000KHz VBW:3000.000KHz SWT:Auto Detector : Peak Project : 671336-04 Mode : 15 Power : 14</p>	<p>Date: 2017-12-22</p> <p>Site : 03CH13-11Y Condition : PEAK[UNII] 3m HORN_91200_1241 HORIZONTAL RBW:1000.000KHz VBW:3000.000KHz SWT:Auto Detector : Peak Project : 671336-04 Mode : 15 Power : 14</p>



WIFI	Band 3 5470~5725MHz Band Edge @ 3m	
ANT	802.11n HT20 CH140 5700MHz	
1	Vertical	Fundamental
Peak.	<p>Site : 03CH13-11Y Condition : PEAK_BE[UNII], B3 3m HORN_91200_1241 VERTICAL : RBW:1000.000KHz VBW:3000.000KHz SWT:Auto Detector : Peak Project : 671336-04 Mode : 15 Power : 14</p>	<p>Site : 03CH13-11Y Condition : PEAK[UNII] 3m HORN_91200_1241 VERTICAL : RBW:1000.000KHz VBW:3000.000KHz SWT:Auto Detector : Peak Project : 671336-04 Mode : 15 Power : 14</p>



**Band 3 5470~5725MHz
WIFI 802.11n HT40 (Band Edge @ 3m)**

WIFI	Band 3 5470~5725MHz Band Edge @ 3m	
ANT	802.11n HT40 CH102 5510MHz - L	
1	Horizontal	Fundamental
Peak	<p>Site : 03CH13-HY Condition : PEAK_BE(UNIT1)_B3 3m HORN_91200_1241 HORIZONTAL Detector : Peak Project : 671336-04 Mode : 16 Power : 15</p>	<p>Site : 03CH13-HY Condition : PEAK(UNIT1) 3m HORN_91200_1241 HORIZONTAL Detector : Peak Project : 671336-04 Mode : 16 Power : 15</p>
Avg.	<p>Site : 03CH13-HY Condition : AVG_BE(UNIT1)_B3 3m HORN_91200_1241 HORIZONTAL Detector : Peak Project : 671336-04 Mode : 16 Power : 15</p>	Left blank



WIFI	Band 3 5470~5725MHz Band Edge @ 3m	
ANT	802.11n HT40 CH102 5510MHz - R	
1	Horizontal	Fundamental
Peak	<p>Site : D8CH13-4/F Condition : PEAK_BE([UNIT]), B3 3m HORN_91200_1241 HORIZONTAL Detector : Peak Project : 671336-04 Mode : 16 Power : 15</p>	Left blank



WIFI	Band 3 5470~5725MHz Band Edge @ 3m	
ANT	802.11n HT40 CH102 5510MHz - L	
1	Vertical	Fundamental
Peak	<p>Site : 03CH13-HY Condition : PEAK_BE(UNIT), B3 3m HORN_91200_1241 VERTICAL : RBW:1000.000KHz VBW:3000.000KHz SWT:Auto Detector : Peak Project : 671336-04 Mode : 16 Power : 15</p>	<p>Site : 03CH13-HY Condition : PEAK(UNIT) 3m HORN_91200_1241 VERTICAL : RBW:1000.000KHz VBW:3000.000KHz SWT:Auto Detector : Peak Project : 671336-04 Mode : 16 Power : 15</p>
Avg.	<p>Site : 03CH13-HY Condition : AVG_BE(UNIT), B3 3m HORN_91200_1241 VERTICAL : RBW:1000.000KHz VBW:0.010KHz SWT:Auto Detector : Peak Project : 671336-04 Mode : 16 Power : 15</p>	Left blank



WIFI	Band 3 5470~5725MHz Band Edge @ 3m	
ANT	802.11n HT40 CH102 5510MHz - R	
1	Vertical	Fundamental
Peak	<p>Site : D3CH13-4/F Condition : PEAK_BE([UNIT]), B3 3m HORN_91200_1241 VERTICAL Detector : Peak Project : 671336-04 Mode : 16 Power : 15</p>	Left blank

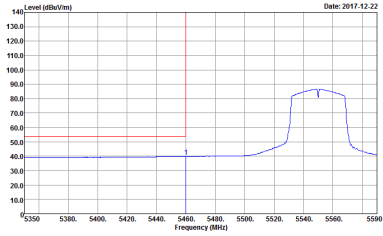

WIFI	Band 3 5470~5725MHz Band Edge @ 3m	
ANT	802.11n HT40 CH110 5550MHz - L	
1	Horizontal	Fundamental
Peak	 <p>Site : 03CH13-HY Condition : PEAK_BE(UNIT), B3 3m HORN_91200_1241 HORIZONTAL : RBW:1000.000KHz VBW:3000.000KHz SWT:Auto Detector : Peak Project : 671336-04 Mode : 17 Power : 14</p>	 <p>Site : 03CH13-HY Condition : PEAK(UNIT) 3m HORN_91200_1241 HORIZONTAL : RBW:1000.000KHz VBW:3000.000KHz SWT:Auto Detector : Peak Project : 671336-04 Mode : 17 Power : 14</p>
Avg.	 <p>Site : 03CH13-HY Condition : AVG_BE(UNIT), B3 3m HORN_91200_1241 HORIZONTAL : RBW:1000.000KHz VBW:0.010KHz SWT:Auto Detector : Peak Project : 671336-04 Mode : 17 Power : 14</p>	Left blank



WIFI	Band 3 5470~5725MHz Band Edge @ 3m	
ANT	802.11n HT40 CH110 5550MHz - R	
1	Horizontal	Fundamental
Peak	<p>Site : D8CH13-4/F Condition : PEAK_BE([UNIT]), B3 3m HORN_91200_1241 HORIZONTAL Detector : Peak Project : 671336-04 Mode : 17 Power : 14</p>	Left blank



WIFI	Band 3 5470~5725MHz Band Edge @ 3m	
ANT	802.11n HT40 CH110 5550MHz - L	
1	Vertical	Fundamental
Peak	<p>Site : 03CH13-HY Condition : PEAK_BE(UNIT), B3 3m HORN_91200_1241 VERTICAL : RBW:1000.000KHz VBW:3000.000KHz SWT:Auto Detector : Peak Project : 671336-04 Mode : 17 Power : 14</p>	<p>Site : 03CH13-HY Condition : PEAK(UNIT) 3m HORN_91200_1241 VERTICAL : RBW:1000.000KHz VBW:3000.000KHz SWT:Auto Detector : Peak Project : 671336-04 Mode : 17 Power : 14</p>
Avg.	<p>Site : 03CH13-HY Condition : AVG_BE(UNIT), B3 3m HORN_91200_1241 VERTICAL : RBW:1000.000KHz VBW:0.010KHz SWT:Auto Detector : Peak Project : 671336-04 Mode : 17 Power : 14</p>	Left blank



WIFI	Band 3 5470~5725MHz Band Edge @ 3m	
ANT	802.11n HT40 CH110 5550MHz - R	
1	Vertical	Fundamental
Peak	<p>Site : D8CH13-4/F Condition : PEAK_BE([UNIT]), B3 3m HORN_91200_1241 VERTICAL Detector : Peak Project : 671336-04 Mode : 17 Power : 14</p>	Left blank

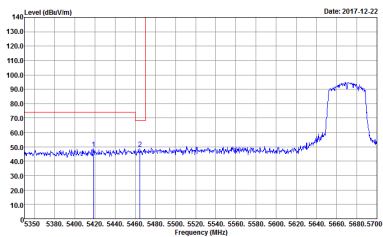
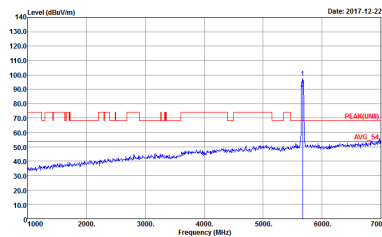
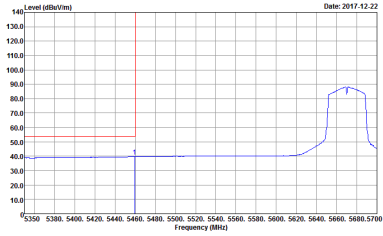

WIFI	Band 3 5470~5725MHz Band Edge @ 3m	
ANT	802.11n HT40 CH134 5670MHz - L	
1	Horizontal	Fundamental
Peak	 <p>Date: 2017.12.22</p> <p>Site : 03CH13-HY Condition : PEAK_BE(UNIT), B3 3m HORN_9120D_1241 HORIZONTAL RBW:1000.000KHz VBW:3000.000KHz SWT:Auto Detector : Peak Project : 671336-04 Mode : 1B Power : 14</p>	 <p>Date: 2017.12.22</p> <p>Site : 03CH13-HY Condition : PEAK(UNIT) 3m HORN_9120D_1241 HORIZONTAL RBW:1000.000KHz VBW:3000.000KHz SWT:Auto Detector : Peak Project : 671336-04 Mode : 1B Power : 14</p>
Avg.	 <p>Date: 2017.12.22</p> <p>Site : 03CH13-HY Condition : AVG_BE(UNIT), B3 3m HORN_9120D_1241 HORIZONTAL RBW:1000.000KHz VBW:0.010KHz SWT:Auto Detector : Peak Project : 671336-04 Mode : 1B Power : 14</p>	Left blank



WIFI	Band 3 5470~5725MHz Band Edge @ 3m	
ANT	802.11n HT40 CH134 5670MHz - R	
1	Horizontal	Fundamental
Peak	<p>Site : D8CH134-RF Condition : PEAK_BE([UNIT]), B3 3m HORN_91200_1241 HORIZONTAL Detector : Peak Project : 671336-04 Mode : 1B Power : 14</p>	Left blank



WIFI	Band 3 5470~5725MHz Band Edge @ 3m	
ANT	802.11n HT40 CH134 5670MHz - L	
1	Vertical	Fundamental
<p>Peak</p>	<p>Site : 03CH13-HY Condition : PEAK_BE(UNIT), B3 3m HORN_9120D_1241 VERTICAL RBW:1000.000KHz VBW:3000.000KHz SWT:Auto Detector : Peak Project : 671336-04 Mode : 1B Power : 14</p>	<p>Site : 03CH13-HY Condition : PEAK(UNIT) 3m HORN_9120D_1241 VERTICAL RBW:1000.000KHz VBW:3000.000KHz SWT:Auto Detector : Peak Project : 671336-04 Mode : 1B Power : 14</p>
<p>Avg.</p>	<p>Site : 03CH13-HY Condition : AVG_BE(UNIT), B3 3m HORN_9120D_1241 VERTICAL RBW:1000.000KHz VBW:0.010KHz SWT:Auto Detector : Peak Project : 671336-04 Mode : 1B Power : 14</p>	<p>Left blank</p>



WIFI	Band 3 5470~5725MHz Band Edge @ 3m	
ANT	802.11n HT40 CH134 5670MHz - R	
1	Vertical	Fundamental
Peak	<p>Site : D8CH134-F Condition : PEAK_BE([UNIT]), B3 3m HORN_91200_1241 VERTICAL Detector : Peak Project : 671336-04 Mode : 1B Power : 14</p>	Left blank



Band 3 5470~5725MHz
WIFI 802.11ac VHT80 (Band Edge @ 3m)

WIFI	Band 3 5470~5725MHz Band Edge @ 3m	
ANT	802.11ac VHT80 CH106 5530MHz - L	
1	Horizontal	Fundamental
Peak	<p>Site : 03CH13-HY Condition : PEAK_BE(UNIT1)_B3 3m HORN_91200_1241 HORIZONTAL Detector : Peak Project : 671336-04 Mode : 19 Power : 13</p>	<p>Site : 03CH13-HY Condition : PEAK(UNIT1) 3m HORN_91200_1241 HORIZONTAL Detector : Peak Project : 671336-04 Mode : 19 Power : 13</p>
Avg.	<p>Site : 03CH13-HY Condition : AVG_BE(UNIT1)_B3 3m HORN_91200_1241 HORIZONTAL Detector : Peak Project : 671336-04 Mode : 19 Power : 13</p>	Left blank



WIFI	Band 3 5470~5725MHz Band Edge @ 3m	
ANT	802.11ac VHT80 CH106 5530MHz - R	
1	Horizontal	Fundamental
Peak	<p>Site : D8CH13-4/F Condition : PEAK_BE([UNIT]), B3 3m HORN_91200_1241 HORIZONTAL Detector : Peak Project : 671336-04 Mode : 19 Power : 13</p>	Left blank



WIFI	Band 3 5470~5725MHz Band Edge @ 3m	
ANT	802.11ac VHT80 CH106 5530MHz - L	
1	Vertical	Fundamental
Peak	<p>Site : 03CH13-HY Condition : PEAK_BE(UNIT), B3 3m HORN_91200_1241 VERTICAL : RBW:1000.000KHz VBW:3000.000KHz SWT:Auto Detector : Peak Project : 671336-04 Mode : 19 Power : 13</p>	<p>Site : 03CH13-HY Condition : PEAK(UNIT) 3m HORN_91200_1241 VERTICAL : RBW:1000.000KHz VBW:3000.000KHz SWT:Auto Detector : Peak Project : 671336-04 Mode : 19 Power : 13</p>
Avg.	<p>Site : 03CH13-HY Condition : AVG_BE(UNIT), B3 3m HORN_91200_1241 VERTICAL : RBW:1000.000KHz VBW:0.010KHz SWT:Auto Detector : Peak Project : 671336-04 Mode : 19 Power : 13</p>	Left blank



WIFI	Band 3 5470~5725MHz Band Edge @ 3m	
ANT	802.11ac VHT80 CH106 5530MHz - R	
1	Vertical	Fundamental
Peak	<p>Site : D8C4E3-4/F Condition : PEAK_BE([UNIT]), B3 3m HORN_91200_1241 VERTICAL Detector : Peak Project : 671336-04 Mode : 19 Power : 13</p>	Left blank



WIFI	Band 3 5470~5725MHz Band Edge @ 3m	
ANT	802.11ac VHT80 CH122 5610MHz - L	
1	Horizontal	Fundamental
<p>Peak</p>	<p>Site : 03CH13-HY Condition : PEAK_BE(UNIT), B3 3m HORN_91200_1241 HORIZONTAL : RBW:1000.000KHz VBW:3000.000KHz SWT:Auto Detector : Peak Project : 671336-04 Mode : 20 Power : 13</p>	<p>Site : 03CH13-HY Condition : PEAK(UNIT) 3m HORN_91200_1241 HORIZONTAL : RBW:1000.000KHz VBW:3000.000KHz SWT:Auto Detector : Peak Project : 671336-04 Mode : 20 Power : 13</p>
<p>Avg.</p>	<p>Site : 03CH13-HY Condition : AVG_BE(UNIT), B3 3m HORN_91200_1241 HORIZONTAL : RBW:1000.000KHz VBW:0.010KHz SWT:Auto Detector : Peak Project : 671336-04 Mode : 20 Power : 13</p>	<p>Left blank</p>



WIFI	Band 3 5470~5725MHz Band Edge @ 3m	
ANT	802.11ac VHT80 CH122 5610MHz - R	
1	Horizontal	Fundamental
Peak	<p>Site : D8CH123-4/F Condition : PEAK_BE([UNIT]), B3 3m HORN_91200_1241 HORIZONTAL Detector : Peak Project : 671336-04 Mode : 20 Power : 13</p>	Left blank

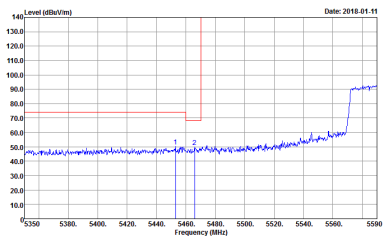
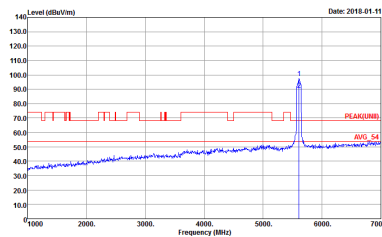
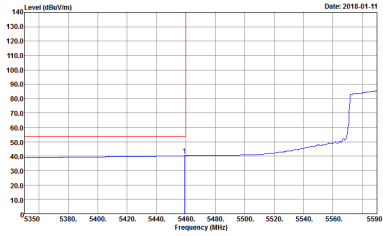

WIFI	Band 3 5470~5725MHz Band Edge @ 3m	
ANT	802.11ac VHT80 CH122 5610MHz - L	
1	Vertical	Fundamental
Peak	 <p>Site : 03CH13-HY Condition : PEAK_BE(UNIT), B3 3m HORN_91200_1241 VERTICAL : RBW:1000.000KHz VBW:3000.000KHz SWT:Auto Detector : Peak Project : 671336-04 Mode : 20 Power : 13</p>	 <p>Site : 03CH13-HY Condition : PEAK(UNIT) 3m HORN_91200_1241 VERTICAL : RBW:1000.000KHz VBW:3000.000KHz SWT:Auto Detector : Peak Project : 671336-04 Mode : 20 Power : 13</p>
Avg.	 <p>Site : 03CH13-HY Condition : AVG_BE(UNIT), B3 3m HORN_91200_1241 VERTICAL : RBW:1000.000KHz VBW:0.010KHz SWT:Auto Detector : Peak Project : 671336-04 Mode : 20 Power : 13</p>	Left blank



WIFI	Band 3 5470~5725MHz Band Edge @ 3m	
ANT	802.11ac VHT80 CH122 5610MHz - R	
1	Vertical	Fundamental
Peak	<p>Site : D8C4E3-4/F Condition : PEAK_BE([UNIT]), B3 3m HORN_91200_1241 VERTICAL Detector : Peak Project : 671336-04 Mode : 20 Power : 13</p>	Left blank

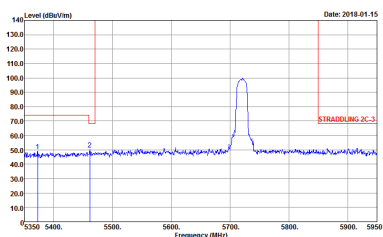
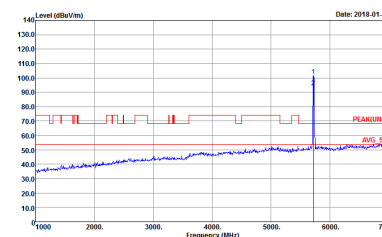
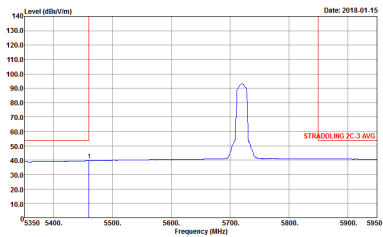

Band 3 - Straddle Channel

WIFI	Band 3 5470~5725MHz Band Edge @ 3m	
ANT	802.11a CH144 5720MHz - L	
1	Horizontal	Fundamental
Peak	 <p>Site : 03CH13-HY Condition : STRADDLING 2C-3 3m HORN_91200_1241 HORIZONTAL Detector : Peak Project : 671336-04 Mode : Z2 Power : 14</p>	 <p>Site : 03CH13-HY Condition : PEAKUNII 3m HORN_91200_1241 HORIZONTAL Detector : Peak Project : 671336-04 Mode : Z2 Power : 14</p>
	 <p>Site : 03CH13-HY Condition : STRADDLING 2C-3 AV6 3m HORN_91200_1241 HORIZONTAL Detector : Peak Project : 671336-04 Mode : Z2 Power : 14</p>	Left blank



WIFI	Band 3 5470~5725MHz Band Edge @ 3m	
ANT	802.11a CH144 5720MHz - R	
1	Horizontal	Fundamental
Peak	<p>Site : DSCH123456 Condition : STRAIDLING 2C-3 3m HORN_91200_1241 HORIZONTAL Detector : Peak Project : 671336-04 Mode : Z2 Power : 14</p>	Left blank



WIFI	Band 3 5470~5725MHz Band Edge @ 3m	
ANT	802.11a CH144 5720MHz - L	
1	Vertical	Fundamental
Peak	<p>Site : 03CH13-HY Condition : STRADDLING 2C-3 3m HORN_91200_1241 VERTICAL RBW:1000.000KHz VBW:3000.000KHz SWT:Auto Detector : Peak Project : 671336-04 Mode : Z2 Power : 14</p>	<p>Site : 03CH13-HY Condition : PEAKUNII 3m HORN_91200_1241 VERTICAL RBW:1000.000KHz VBW:3000.000KHz SWT:Auto Detector : Peak Project : 671336-04 Mode : Z2 Power : 14</p>
Avg.	<p>Site : 03CH13-HY Condition : STRADDLING 2C-3 AVG 3m HORN_91200_1241 VERTICAL RBW:1000.000KHz VBW:0.010KHz SWT:Auto Detector : Peak Project : 671336-04 Mode : Z2 Power : 14</p>	Left blank



WIFI	Band 3 5470~5725MHz Band Edge @ 3m	
ANT	802.11a CH144 5720MHz - R	
1	Vertical	Fundamental
Peak	<p>Site : D8CH12-411 Condition : STRADDLING 2C-3 3m HORN_91200_1241 VERTICAL Detector : Peak Project : 672336-04 Mode : Z2 Power : 14</p>	Left blank

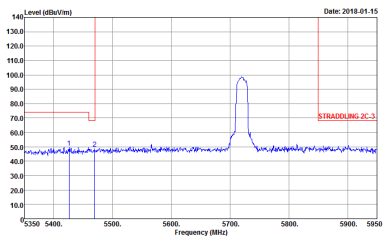
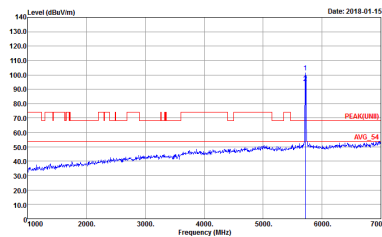
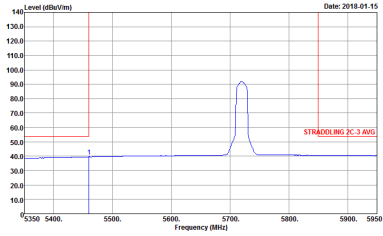

WIFI	Band 3 5470~5725MHz Band Edge @ 3m	
ANT	802.11n HT20 CH144 5720MHz - L	
1	Horizontal	Fundamental
<p>Peak</p>	 <p>Site : 03CH13-HY Condition : STRADDLING 2C-3 3m HORN_91200_1241 HORIZONTAL RBW:1000.000KHz VBW:3000.000KHz SWT:Auto Detector : Peak Project : 671336-04 Mode : Z3 Power : 14</p>	 <p>Site : 03CH13-HY Condition : PEAKUNII 3m HORN_91200_1241 HORIZONTAL RBW:1000.000KHz VBW:3000.000KHz SWT:Auto Detector : Peak Project : 671336-04 Mode : Z3 Power : 14</p>
<p>Avg.</p>	 <p>Site : 03CH13-HY Condition : STRADDLING 2C-3 AV6 3m HORN_91200_1241 HORIZONTAL RBW:1000.000KHz VBW:0.010KHz SWT:Auto Detector : Peak Project : 671336-04 Mode : Z3 Power : 14</p>	<p>Left blank</p>



WIFI	Band 3 5470~5725MHz Band Edge @ 3m	
ANT	802.11n HT20 CH144 5720MHz - R	
1	Horizontal	Fundamental
Peak	<p>Site : DSCH12-APF Condition : STRAIDLING 2C-3 3m HORN_91200_1241 HORIZONTAL Detector : Peak Project : 671336-04 Mode : Z3 Power : 14</p>	Left blank

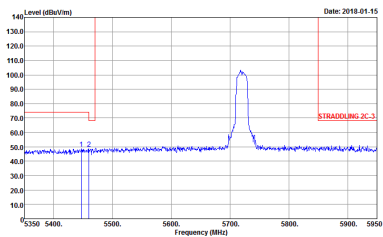
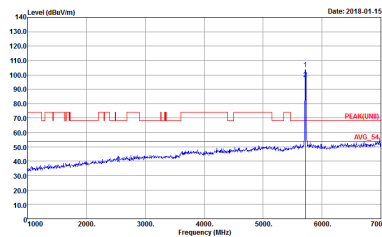
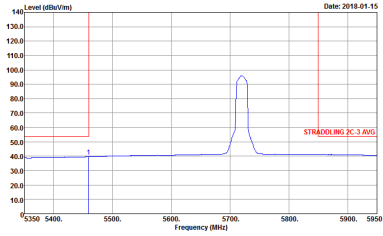

WIFI	Band 3 5470~5725MHz Band Edge @ 3m	
ANT	802.11n HT20 CH144 5720MHz - L	
1	Vertical	Fundamental
Peak	 <p>Date: 2018-01-15</p> <p>Site : 03CH13-HY Condition : STRADDLING 2C-3 3m HORN_91200_1241 VERTICAL RBW:1000.000KHz VBW:3000.000KHz SWT:Auto Detector : Peak Project : 671336-04 Mode : Z3 Power : 14</p>	 <p>Date: 2018-01-15</p> <p>Site : 03CH13-HY Condition : PEAKUNII 3m HORN_91200_1241 VERTICAL RBW:1000.000KHz VBW:3000.000KHz SWT:Auto Detector : Peak Project : 671336-04 Mode : Z3 Power : 14</p>
Avg.	 <p>Date: 2018-01-15</p> <p>Site : 03CH13-HY Condition : STRADDLING 2C-3 AV6 3m HORN_91200_1241 VERTICAL RBW:1000.000KHz VBW:0.010KHz SWT:Auto Detector : Peak Project : 671336-04 Mode : Z3 Power : 14</p>	Left blank



WIFI	Band 3 5470~5725MHz Band Edge @ 3m	
ANT	802.11n HT20 CH144 5720MHz - R	
1	Vertical	Fundamental
Peak	<p>Site : DSCH12-499 Condition : STRAIDLING 2C-3 3m HORN_91200_1241 VERTICAL Detector : Peak Project : 671336-04 Mode : Z3 Power : 14</p>	Left blank

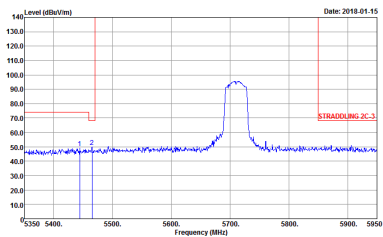
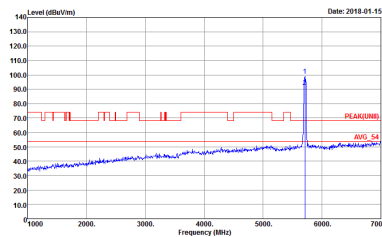
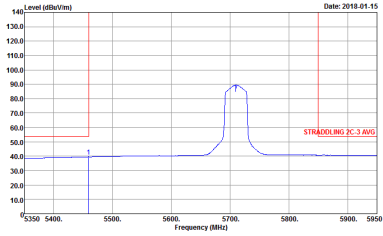

WIFI	Band 3 5470~5725MHz Band Edge @ 3m	
ANT	802.11n HT40 CH142 5710MHz - L	
1	Horizontal	Fundamental
Peak	 <p>Site : 03CH13-HY Condition : STRADDLING 2C-3 3m HORN_91200_1241 HORIZONTAL RBW:1000.000KHz VBW:3000.000KHz SWT:Auto Detector : Peak Project : 671336-04 Mode : 24 Power : 14</p>	 <p>Site : 03CH13-HY Condition : PEAKUNII 3m HORN_91200_1241 HORIZONTAL RBW:1000.000KHz VBW:3000.000KHz SWT:Auto Detector : Peak Project : 671336-04 Mode : 24 Power : 14</p>
Avg.	 <p>Site : 03CH13-HY Condition : STRADDLING 2C-3 AVG 3m HORN_91200_1241 HORIZONTAL RBW:1000.000KHz VBW:0.010KHz SWT:Auto Detector : Peak Project : 671336-04 Mode : 24 Power : 14</p>	Left blank



WIFI	Band 3 5470~5725MHz Band Edge @ 3m	
ANT	802.11n HT40 CH142 5710MHz - R	
1	Horizontal	Fundamental
Peak	<p>Site : DSCH12-APF Condition : STRADDLING 2C-3 3m HORN_91200_1241 HORIZONTAL Detector : Peak Project : 671336-04 Mode : 24 Power : 14</p>	Left blank



WIFI	Band 3 5470~5725MHz Band Edge @ 3m	
ANT	802.11n HT40 CH142 5710MHz - L	
1	Vertical	Fundamental
Peak	<p>Site : 03CH13-HY Condition : STRADDLING 2C-3 3m HORN_91200_1241 VERTICAL RBW:1000.000KHz VBW:3000.000KHz SWT:Auto Detector : Peak Project : 671336-04 Mode : 24 Power : 14</p>	<p>Site : 03CH13-HY Condition : PEAK(LIN) 3m HORN_91200_1241 VERTICAL RBW:1000.000KHz VBW:3000.000KHz SWT:Auto Detector : Peak Project : 671336-04 Mode : 24 Power : 14</p>
Avg.	<p>Site : 03CH13-HY Condition : STRADDLING 2C-3 AVG 3m HORN_91200_1241 VERTICAL RBW:1000.000KHz VBW:3000.000KHz SWT:Auto Detector : Peak Project : 671336-04 Mode : 24 Power : 14</p>	Left blank



WIFI	Band 3 5470~5725MHz Band Edge @ 3m	
ANT	802.11n HT40 CH142 5710MHz - R	
1	Vertical	Fundamental
Peak	<p>Site : D8CH12-477 Condition : STRADDLING 2C-3 3m HORN_91200_1241 VERTICAL Detector : Peak Project : 672336-04 Mode : 24 Power : 14</p>	Left blank

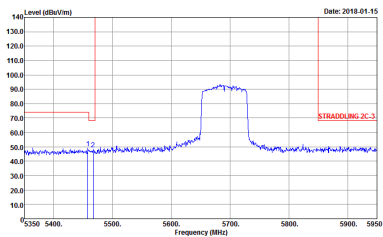
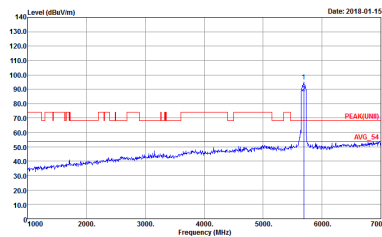
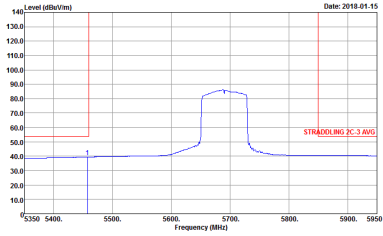

WIFI	Band 3 5470~5725MHz Band Edge @ 3m	
ANT	802.11ac VHT80 CH138 5690MHz - L	
1	Horizontal	Fundamental
Peak	 <p>Site : 03CH13-HY Condition : STRADDLING 2C-3 3m HORN_91200_1241 HORIZONTAL RBW:1000.000KHz VBW:3000.000KHz SWT:Auto Detector : Peak Project : 671336-04 Mode : 25 Power : 14</p>	 <p>Site : 03CH13-HY Condition : PEAKUNII 3m HORN_91200_1241 HORIZONTAL RBW:1000.000KHz VBW:3000.000KHz SWT:Auto Detector : Peak Project : 671336-04 Mode : 25 Power : 14</p>
Avg.	 <p>Site : 03CH13-HY Condition : STRADDLING 2C-3 AVG 3m HORN_91200_1241 HORIZONTAL RBW:1000.000KHz VBW:0.010KHz SWT:Auto Detector : Peak Project : 671336-04 Mode : 25 Power : 14</p>	Left blank



WIFI	Band 3 5470~5725MHz Band Edge @ 3m	
ANT	802.11ac VHT80 CH138 5690MHz - R	
1	Horizontal	Fundamental
Peak	<p>Site : D8CH138-477 Condition : STRADDLING 2C-3 3m HORN_91200_1241 HORIZONTAL Detector : Peak Project : 671336-04 Mode : Z5 Power : 14</p>	Left blank

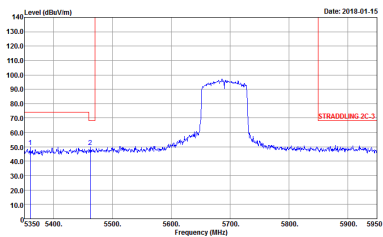
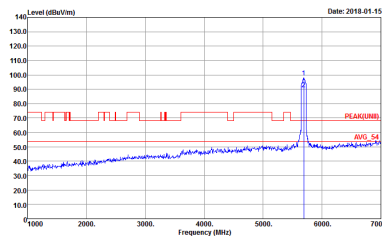
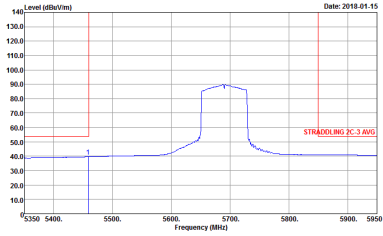

WIFI	Band 3 5470~5725MHz Band Edge @ 3m	
ANT	802.11ac VHT80 CH138 5690MHz - L	
1	Vertical	Fundamental
Peak	 <p>Date: 2018-01-15</p> <p>Site : 03CH13-HY Condition : STRADDLING 2C-3 3m HORN_91200_1241 VERTICAL RBW:1000.000KHz VBW:3000.000KHz SWT:Auto Detector : Peak Project : 671336-04 Mode : 25 Power : 14</p>	 <p>Date: 2018-01-15</p> <p>Site : 03CH13-HY Condition : PEAKUNII 3m HORN_91200_1241 VERTICAL RBW:1000.000KHz VBW:3000.000KHz SWT:Auto Detector : Peak Project : 671336-04 Mode : 25 Power : 14</p>
Avg.	 <p>Date: 2018-01-15</p> <p>Site : 03CH13-HY Condition : STRADDLING 2C-3 AVG 3m HORN_91200_1241 VERTICAL RBW:1000.000KHz VBW:3000.000KHz SWT:Auto Detector : Peak Project : 671336-04 Mode : 25 Power : 14</p>	Left blank



WIFI	Band 3 5470~5725MHz Band Edge @ 3m	
ANT	802.11ac VHT80 CH138 5690MHz - R	
1	Vertical	Fundamental
Peak	<p>Site : D8CH12-411 Condition : STRADDLING 2C-3 3m HORN_91200_1241 VERTICAL Detector : Peak Project : 671336-04 Mode : Z5 Power : 14</p>	Left blank



Band 3 - 5470~5725MHz
WIFI 802.11a (Harmonic @ 3m)

WIFI	Band 3 5470~5725MHz Harmonic @ 3m	
ANT	802.11a CH100 5500MHz	
1	Horizontal	Vertical
Peak Avg.	<p>Site : 03CH12-11Y Condition : PEAK(LINE) 3m SHF_HORN_576 HORIZONTAL Detector : Peak Project : 671336-04 Mode : 10 Power : 14</p>	<p>Site : 03CH12-11Y Condition : PEAK(LINE) 3m SHF_HORN_576 VERTICAL Detector : Peak Project : 671336-04 Mode : 10 Power : 14</p>



WIFI	Band 3 5470~5725MHz Harmonic @ 3m	
ANT	802.11a CH116 5580MHz	
1	Horizontal	Vertical
Peak Avg.	<p>Site : 03CHE2-11Y Condition : PEA(LINEI) 3m SHF_HORN_576 HORIZONTAL Detector : Peak Project : 671336-04 Mode : 11 Power : 14</p>	<p>Site : 03CHE2-11Y Condition : PEA(LINEI) 3m SHF_HORN_576 VERTICAL Detector : Peak Project : 671336-04 Mode : 11 Power : 14</p>



WIFI	Band 3 5470~5725MHz Harmonic @ 3m	
ANT	802.11a CH140 5700MHz	
1	Horizontal	Vertical
<p>Peak</p> <p>Avg.</p>	<p>Site : 03CHE2-11Y Condition : PEAK(LINE) 3m SHF_HORN_576 HORIZONTAL Detector : Peak Project : 671336-04 Mode : 12 Power : 14</p>	<p>Site : 03CHE2-11Y Condition : PEAK(LINE) 3m SHF_HORN_576 VERTICAL Detector : Peak Project : 671336-04 Mode : 12 Power : 14</p>



**Band 3 5470~5725MHz
WIFI 802.11n HT20 (Harmonic @ 3m)**

WIFI	Band 3 5470~5725MHz Harmonic @ 3m	
ANT	802.11n HT20 CH100 5500MHz	
1	Horizontal	Vertical
<p>Peak</p> <p>Avg.</p>	<p>Site : 03CH13-HY Condition : PEAK(UNIT) 3m SHF_HORN_576 HORIZONTAL Detector : Peak Project : 671336-04 Mode : 13 Power : 15</p>	<p>Site : 03CH13-HY Condition : PEAK(UNIT) 3m SHF_HORN_576 VERTICAL Detector : Peak Project : 671336-04 Mode : 13 Power : 15</p>

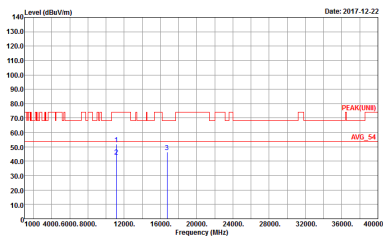
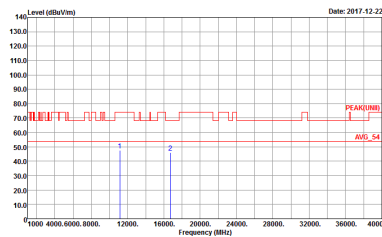

WIFI	Band 3 5470~5725MHz Harmonic @ 3m	
ANT	802.11n HT20 CH116 5580MHz	
1	Horizontal	Vertical
Peak Avg.	 <p>Site : 03CH12-11Y Condition : PEAK(UNII) 3m SHF_HORN_576 HORIZONTAL Detector : Peak Project : 671336-04 Mode : 14 Power : 14</p>	 <p>Site : 03CH12-11Y Condition : PEAK(UNII) 3m SHF_HORN_576 VERTICAL Detector : Peak Project : 671336-04 Mode : 14 Power : 14</p>

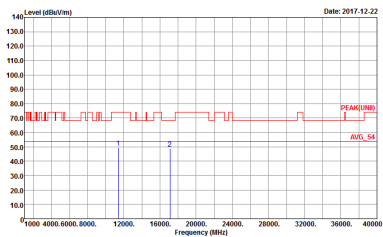
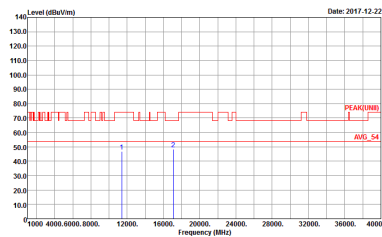

WIFI	Band 3 5470~5725MHz Harmonic @ 3m	
ANT	802.11n HT20 CH140 5700MHz	
1	Horizontal	Vertical
<p>Peak</p> <p>Avg.</p>	 <p>Site : 03CHE2-11Y Condition : PEAK(LINE1) 3m SHF_HORN_576 HORIZONTAL Detector : Peak Project : 671336-04 Mode : 15 Power : 14</p>	 <p>Site : 03CHE2-11Y Condition : PEAK(LINE1) 3m SHF_HORN_576 VERTICAL Detector : Peak Project : 671336-04 Mode : 15 Power : 14</p>



Band 3 5470~5725MHz
WIFI 802.11n HT40 (Harmonic @ 3m)

WIFI	Band 3 5470~5725MHz Harmonic @ 3m	
ANT	802.11n HT40 CH102 5510MHz	
1	Horizontal	Vertical
Peak Avg.	<p>Site : 03CH13-HY Condition : PEAK(UNIT) 3m SHF_HORN_576 HORIZONTAL Detector : Peak Project : 671336-04 Mode : 16 Power : 15</p>	<p>Site : 03CH13-HY Condition : PEAK(UNIT) 3m SHF_HORN_576 VERTICAL Detector : Peak Project : 671336-04 Mode : 16 Power : 15</p>

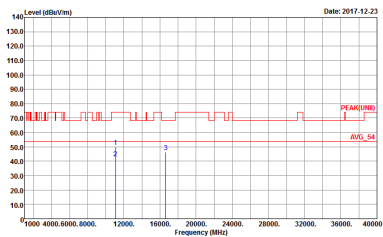
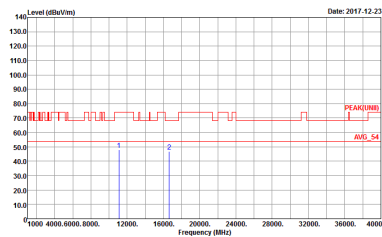

WIFI	Band 3 5470~5725MHz Harmonic @ 3m	
ANT	802.11n HT40 CH110 5550MHz	
1	Horizontal	Vertical
<p>Peak</p> <p>Avg.</p>	 <p>Site : 03CHE2-11Y Condition : PEAK(LINE) 3m SHF_HORN_576 HORIZONTAL Detector : Peak Project : 671336-04 Mode : 17 Power : 14</p>	 <p>Site : 03CHE2-11Y Condition : PEAK(LINE) 3m SHF_HORN_576 VERTICAL Detector : Peak Project : 671336-04 Mode : 17 Power : 14</p>

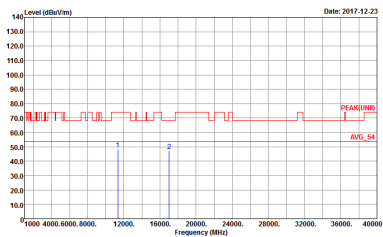
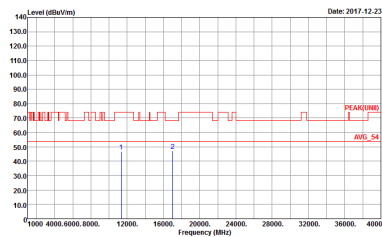

WIFI	Band 3 5470~5725MHz Harmonic @ 3m	
ANT	802.11n HT40 CH134 5670MHz	
1	Horizontal	Vertical
<p>Peak</p> <p>Avg.</p>	 <p>Site : 03CHE2-11Y Condition : PEAK(LINE1) 3m SHF_HORN_576 HORIZONTAL Detector : Peak Project : 671336-04 Mode : 1B Power : 14</p>	 <p>Site : 03CHE2-11Y Condition : PEAK(LINE1) 3m SHF_HORN_576 VERTICAL Detector : Peak Project : 671336-04 Mode : 1B Power : 14</p>



**Band 3 5470~5725MHz
WIFI 802.11ac VHT80 (Harmonic @ 3m)**

WIFI	Band 3 5470~5725MHz Harmonic @ 3m	
ANT	802.11ac VHT80 CH106 5530MHz	
1	Horizontal	Vertical
Peak Avg.	<p>Site : 03CH13-HY Condition : PEAK(UNIT) 3m SHF_HORN_576 HORIZONTAL Detector : Peak Project : 671336-04 Mode : 19 Power : 13</p>	<p>Site : 03CH13-HY Condition : PEAK(UNIT) 3m SHF_HORN_576 VERTICAL Detector : Peak Project : 671336-04 Mode : 19 Power : 13</p>

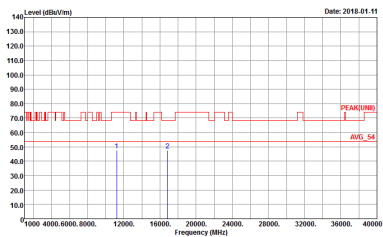
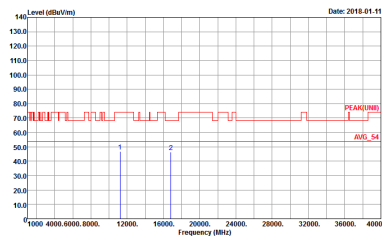

WIFI	Band 3 5470~5725MHz Harmonic @ 3m	
ANT	802.11ac VHT80 CH122 5610MHz	
1	Horizontal	Vertical
<p>Peak</p> <p>Avg.</p>	 <p>Site : 03CHE2-11Y Condition : PEAK(LINE) 3m SHF_HORN_576 HORIZONTAL Detector : Peak Project : 671336-04 Mode : 20 Power : 13</p>	 <p>Site : 03CHE2-11Y Condition : PEAK(LINE) 3m SHF_HORN_576 VERTICAL Detector : Peak Project : 671336-04 Mode : 20 Power : 13</p>



Band 3 - Straddle Channel
WIFI 802.11a (Harmonic @ 3m)

WIFI	Band 3 Straddle Channel Harmonic @ 3m	
ANT	802.11a CH144 5720MHz	
1	Horizontal	Vertical
<p>Peak</p> <p>Avg.</p>	<p>Site : 03CH13-HY Condition : PEAK(UNIT) 3m SHF_HORN_576 HORIZONTAL Detector : Peak Project : 671336-04 Mode : Z2 Power : 14</p>	<p>Site : 03CH13-HY Condition : PEAK(UNIT) 3m SHF_HORN_576 VERTICAL Detector : Peak Project : 671336-04 Mode : Z2 Power : 14</p>



Band 3 – Straddle Channel
WIFI 802.11n HT20 (Harmonic @ 3m)

WIFI	Band 3 Straddle Channel Harmonic @ 3m	
ANT	802.11n HT20 CH144 5720MHz	
1	Horizontal	Vertical
<p>Peak</p> <p>Avg.</p>	<p>Site : 03CH13-HY Condition : PEAK(UNIT) 3m SHF_HORN_576 HORIZONTAL Detector : Peak Project : 671336-04 Mode : 23 Power : 14</p>	<p>Site : 03CH13-HY Condition : PEAK(UNIT) 3m SHF_HORN_576 VERTICAL Detector : Peak Project : 671336-04 Mode : 23 Power : 14</p>



Band 3 – Straddle Channel
WIFI 802.11n HT40 (Harmonic @ 3m)

WIFI	Band 3 Straddle Channel Harmonic @ 3m	
ANT	802.11n HT40 CH142 5710MHz	
1	Horizontal	Vertical
Peak Avg.	<p>Site : 03CH13-HY Condition : PEAK(UNIT) 3m SHF_HORN_576 HORIZONTAL Detector : Peak Project : 671336-04 Mode : 24 Power : 14</p>	<p>Site : 03CH13-HY Condition : PEAK(UNIT) 3m SHF_HORN_576 VERTICAL Detector : Peak Project : 671336-04 Mode : 24 Power : 14</p>



Band 3 – Straddle Channel
WIFI 802.11ac VHT80 (Harmonic @ 3m)

WIFI	Band 3 Straddle Channel Harmonic @ 3m	
ANT	802.11ac VHT80 CH138 5690MHz	
1	Horizontal	Vertical
Peak Avg.	<p>Site : 03CH13-HY Condition : PEAK(UNII) 3m SHF_HORN_576 HORIZONTAL Detector : Peak Project : 671336-04 Mode : 25 Power : 14</p>	<p>Site : 03CH13-HY Condition : PEAK(UNII) 3m SHF_HORN_576 VERTICAL Detector : Peak Project : 671336-04 Mode : 25 Power : 14</p>



Emission below 1GHz
5GHz WIFI 802.11ac VHT80 (LF)

Table with 2 columns: Horizontal and Vertical. Each column contains a spectral plot of Level (dBuV/m) vs Frequency (MHz) from 50 to 1000 MHz. The plots show a blue signal line and a red limit line. Metadata includes Site: 03CH13-11Y, Condition: QP 3m BILLOG_35414, Detector: Peak, Project: 671336-04, Mode: Z1.



Appendix D. Duty Cycle Plots

Band	Duty Cycle (%)	T(us)	1/T(kHz)	VBW Setting	Duty Factor (dB)
802.11a	100.00	-	-	10Hz	0.00
5GHz 802.11n HT20	100.00	-	-	10Hz	0.00
5GHz 802.11n HT40	100.00	-	-	10Hz	0.00
5GHz 802.11ac VHT20	100.00	-	-	10Hz	0.00
5GHz 802.11ac VHT40	100.00	-	-	10Hz	0.00
5GHz 802.11ac VHT80	100.00	-	-	10Hz	0.00



802.11a

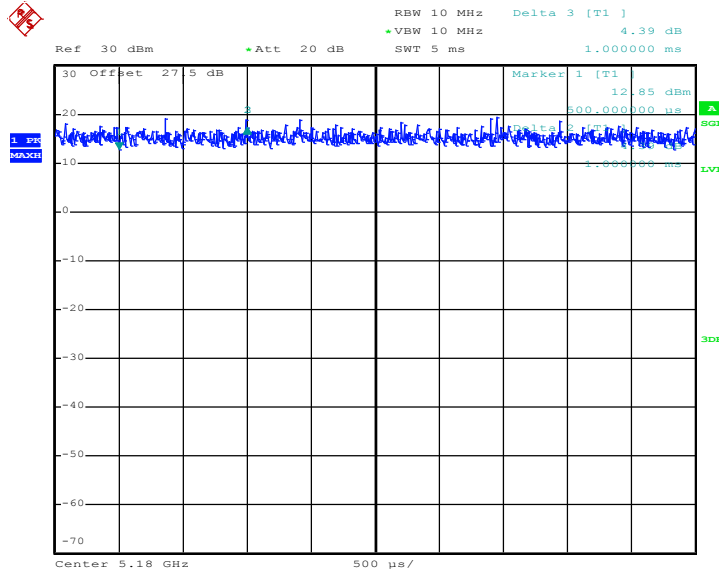

Date: 20.DEC.2017 20:08:30

802.11n HT20

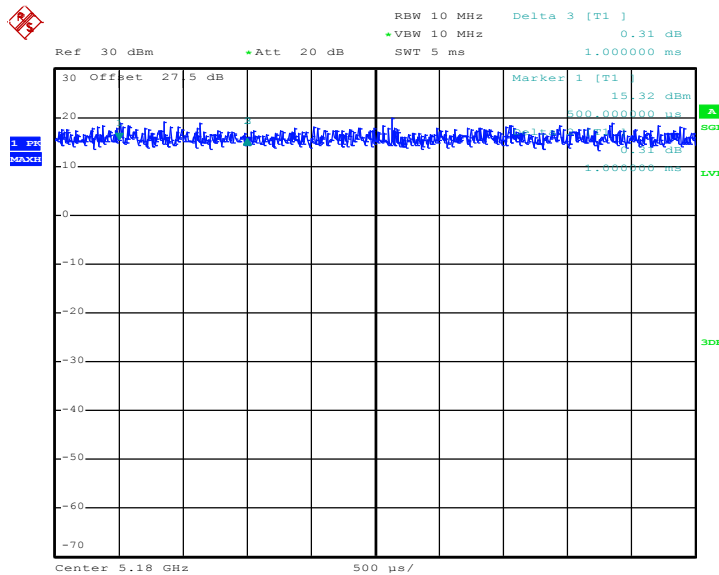

Date: 20.DEC.2017 20:15:26



802.11n HT40

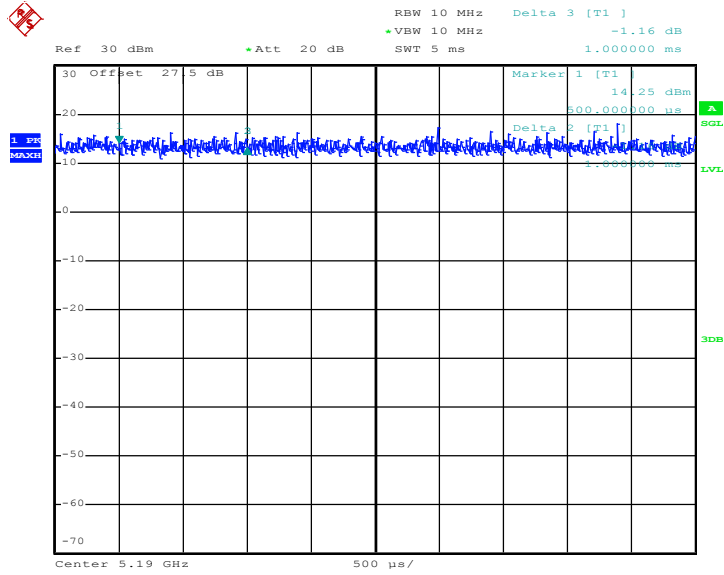

Date: 20.DEC.2017 20:23:54

802.11ac VHT20

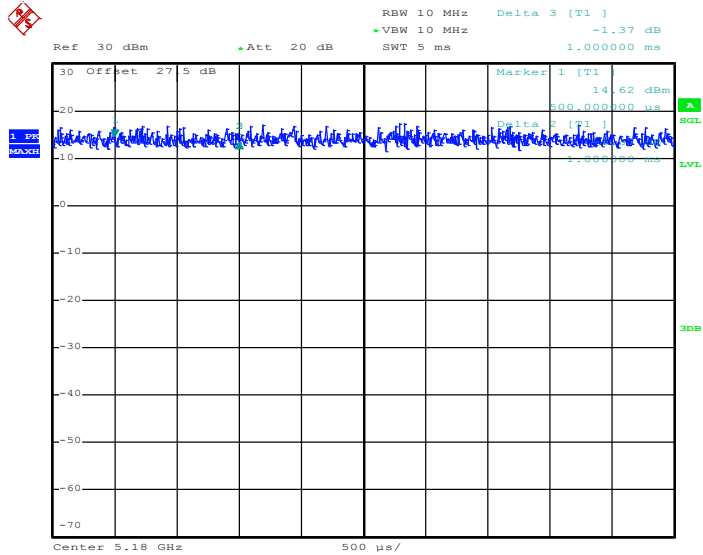

Date: 20.DEC.2017 20:28:50



802.11ac VHT40

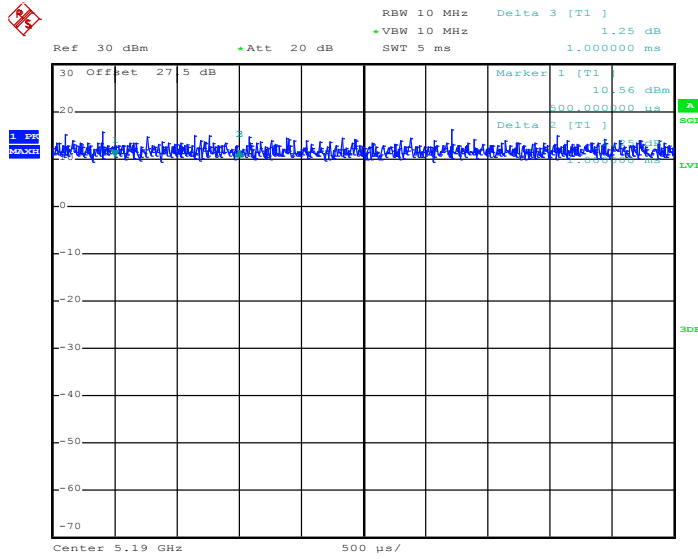

Date: 20.DEC.2017 21:28:30

802.11ac VHT80

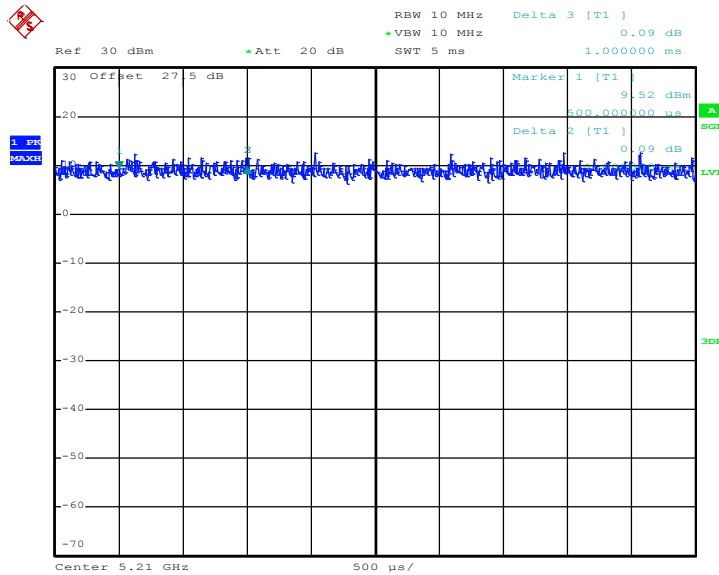

Date: 20.DEC.2017 21:36:08