



FCC RF Test Report

APPLICANT : AzulFlower LLC
EQUIPMENT : Tablet PC
MODEL NAME : SL056ZE
FCC ID : 2AIP5-3975
STANDARD : FCC Part 15 Subpart C §15.247
CLASSIFICATION : (DTS) Digital Transmission System

The testing was completed on Feb. 03, 2017. We, SPORTON INTERNATIONAL INC., would like to declare that the tested sample has been evaluated in accordance with the test procedures and has been in compliance with the applicable technical standards.

The test results in this report apply exclusively to the tested model / sample. Without written approval of SPORTON INTERNATIONAL INC., the test report shall not be reproduced except in full.

Reviewed by: Joseph Lin / Supervisor

Approved by: Jones Tsai / Manager



SPORTON INTERNATIONAL INC.

No. 52, Hwa Ya 1st Rd., Hwa Ya Technology Park, Kwei-Shan District, Tao Yuan City, Taiwan, R.O.C.



TABLE OF CONTENTS

REVISION HISTORY..... 3

SUMMARY OF TEST RESULT 4

1 GENERAL DESCRIPTION 5

 1.1 Applicant 5

 1.2 Product Feature of Equipment Under Test..... 5

 1.3 Product Specification of Equipment Under Test..... 5

 1.4 Modification of EUT 5

 1.5 Testing Location 6

 1.6 Applicable Standards..... 6

2 TEST CONFIGURATION OF EQUIPMENT UNDER TEST 7

 2.1 Carrier Frequency and Channel 7

 2.2 Test Mode..... 7

 2.3 Connection Diagram of Test System..... 8

 2.4 Support Unit used in test configuration and system 9

 2.5 EUT Operation Test Setup 9

 2.6 Measurement Results Explanation Example..... 9

3 TEST RESULT 10

 3.1 6dB and 99% Bandwidth Measurement 10

 3.2 Output Power Measurement..... 12

 3.3 Power Spectral Density Measurement 13

 3.4 Conducted Band Edges and Spurious Emission Measurement 15

 3.5 Radiated Band Edges and Spurious Emission Measurement 31

 3.6 AC Conducted Emission Measurement..... 35

 3.7 Antenna Requirements 39

4 LIST OF MEASURING EQUIPMENT 40

5 UNCERTAINTY OF EVALUATION 41

APPENDIX A. CONDUCTED TEST RESULTS

APPENDIX B. RADIATED SPURIOUS EMISSION

APPENDIX C. RADIATED SPURIOUS EMISSION PLOTS

APPENDIX D. DUTY CYCLE PLOTS



SUMMARY OF TEST RESULT

Report Section	FCC Rule	Description	Limit	Result
3.1	15.247(a)(2)	6dB Bandwidth	$\geq 0.5\text{MHz}$	Pass
3.1	-	99% Bandwidth	-	Pass
3.2	15.247(b)	Power Output Measurement	$\leq 30\text{dBm}$	Pass
3.3	15.247(e)	Power Spectral Density	$\leq 8\text{dBm}/3\text{kHz}$	Pass
3.4	15.247(d)	Conducted Band Edges	$\leq 20\text{dBc}$	Pass
		Conducted Spurious Emission		Pass
3.5	15.247(d)	Radiated Band Edges and Radiated Spurious Emission	15.209(a) & 15.247(d)	Pass
3.6	15.207	AC Conducted Emission	15.207(a)	Pass
3.7	15.203 & 15.247(b)	Antenna Requirement	N/A	Pass



1 General Description

1.1 Applicant

AzulFlower LLC
10 Dorrance Street Suite 700 Providence, RI 02903

1.2 Product Feature of Equipment Under Test

Product Feature	
Equipment	Tablet PC
Model Name	SL056ZE
FCC ID	2AIP5-3975
EUT supports Radios application	WLAN 11b/g/n HT20 WLAN 11a/n HT20/HT40 WLAN 11ac VHT20/VHT40/VHT80 Bluetooth BR/EDR/LE

1.3 Product Specification of Equipment Under Test

Standards-related Product Specification	
Tx/Rx Channel Frequency Range	2412 MHz ~ 2472 MHz
Maximum (Peak) Output Power to antenna	802.11b : 16.08 dBm (0.0406 W) 802.11g : 21.70 dBm (0.1479 W) 802.11n HT20 : 22.09 dBm (0.1618 W)
99% Occupied Bandwidth	802.11b : 13.80MHz 802.11g : 18.35MHz 802.11n HT20 : 18.35MHz
Antenna Type / Gain	Fixed Internal Antenna type with gain 2.10 dBi
Type of Modulation	802.11b : DSSS (DBPSK / DQPSK / CCK) 802.11g/n : OFDM (BPSK / QPSK / 16QAM / 64QAM)

1.4 Modification of EUT

No modifications are made to the EUT during all test items.



1.5 Testing Location

Sporton Lab is accredited to ISO 17025 by Taiwan Accreditation Foundation (TAF code : 1190) and the FCC designation No. TW1190 under the FCC 2.948(e) by Mutual Recognition Agreement (MRA) in FCC Test.

Test Site	SPORTON INTERNATIONAL INC.		
Test Site Location	No. 52, Hwa Ya 1 st Rd., Hwa Ya Technology Park, Kwei-Shan District, Tao Yuan City, Taiwan, R.O.C. TEL: +886-3-327-3456 FAX: +886-3-328-4978		
Test Site No.	Sporton Site No.		
	TH05-HY	CO05-HY	03CH07-HY

Note: The test site complies with ANSI C63.4 2014 requirement.

1.6 Applicable Standards

According to the specifications of the manufacturer, the EUT must comply with the requirements of the following standards:

- ♦ FCC Part 15 Subpart C §15.247
- ♦ FCC KDB Publication No. 558074 D01 DTS Meas. Guidance v03r05
- ♦ ANSI C63.10-2013

Remark: All test items were verified and recorded according to the standards and without any deviation during the test.



2 Test Configuration of Equipment Under Test

The EUT has been associated with peripherals and configuration operated in a manner tended to maximize its emission characteristics in a typical application. Frequency range investigated: conducted emission (150 kHz to 30 MHz) and radiated emission (9 kHz to the 10th harmonic of the highest fundamental frequency or to 40 GHz, whichever is lower). For radiated measurement, pre-scanned in three orthogonal panels, X, Y, Z. The worst cases (X plane) were recorded in this report.

2.1 Carrier Frequency and Channel

Frequency Band	Channel	Freq. (MHz)	Channel	Freq. (MHz)
2400-2483.5 MHz	1	2412	8	2447
	2	2417	9	2452
	3	2422	10	2457
	4	2427	11	2462
	5	2432	12	2467
	6	2437	13	2472
	7	2442	-	-

2.2 Test Mode

Final test mode of conducted test items and radiated spurious emissions are considering the modulation and worse data rates as below table.

Modulation	Data Rate
802.11b	1 Mbps
802.11g	6 Mbps
802.11n HT20	MCS0

Test Cases	
AC Conducted Emission	Mode 1 : WLAN (2.4GHz) Link + Bluetooth Link + MPEG4 + Earphone + MicroSD Card + USB Cable (Charging from Adapter)

2.3 Connection Diagram of Test System

<WLAN Tx Mode>

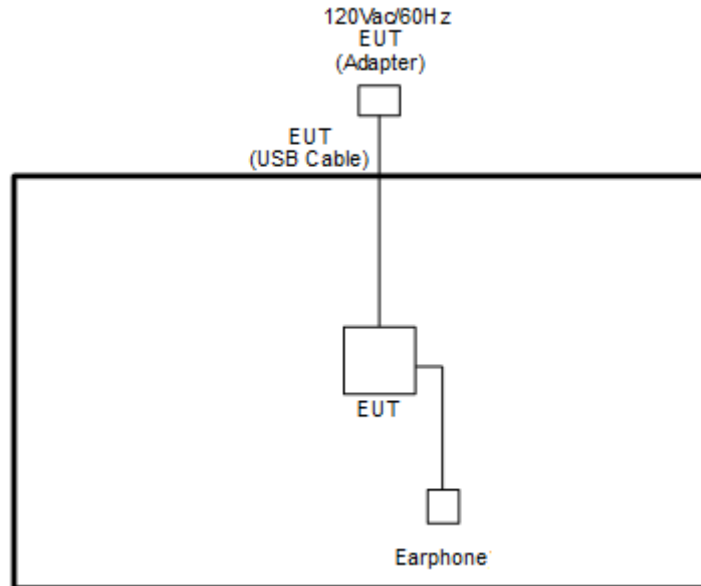

<AC Conducted Emission Mode>

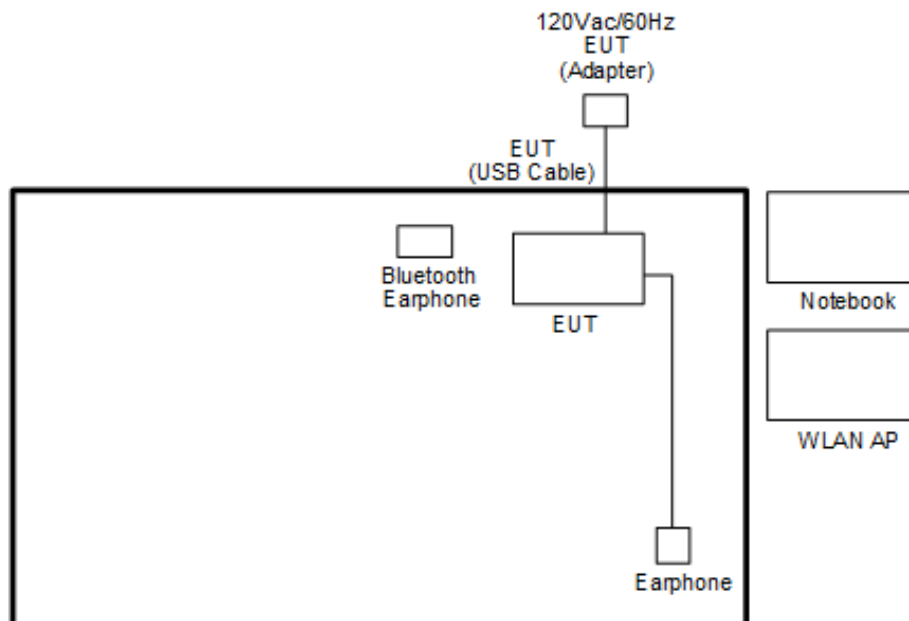



2.4 Support Unit used in test configuration and system

Item	Equipment	Trade Name	Model Name	FCC ID	Data Cable	Power Cord
1.	Bluetooth Earphone	Sony Ericsson	MW600	PY7DDA-2029	N/A	N/A
2.	WLAN AP	ASUS	RT-AC66U	MSQ-RTAC66U	N/A	Unshielded, 1.8 m
3.	Notebook	DELL	Latitude E6320	FCC DoC/ Contains FCC ID: QDS-BRCM1054	N/A	AC I/P: Unshielded, 1.2 m DC O/P: Shielded, 1.8 m
4.	SD Card	SanDisk	MicroSD HC	FCC DoC	N/A	N/A
5.	Earphone	N/A	N/A	Verification	Unshielded, 1.15 m	N/A

2.5 EUT Operation Test Setup

For WLAN function, programmed RF utility, “cmd” installed in the notebook make the EUT provide functions like channel selection and power level for continuous transmitting and receiving signals.

2.6 Measurement Results Explanation Example

For all conducted test items:

The offset level is set in the spectrum analyzer to compensate the RF cable loss and attenuator factor between EUT conducted output port and spectrum analyzer. With the offset compensation, the spectrum analyzer reading level is exactly the EUT RF output level.

Example :

The spectrum analyzer offset is derived from RF cable loss and attenuator factor.

Offset = RF cable loss + attenuator factor.

Following shows an offset computation example with cable loss 4.2 dB and 10dB attenuator.

$$\begin{aligned}
 \text{Offset(dB)} &= \text{RF cable loss(dB)} + \text{attenuator factor(dB)}. \\
 &= 4.2 + 10 = 14.2 \text{ (dB)}
 \end{aligned}$$

3 Test Result

3.1 6dB and 99% Bandwidth Measurement

3.1.1 Limit of 6dB and 99% Bandwidth

The minimum 6 dB bandwidth shall be at least 500 kHz.

3.1.2 Measuring Instruments

The measuring equipment is listed in the section 4 of this test report.

3.1.3 Test Procedures

1. The testing follows FCC KDB Publication No. 558074 DTS D01 Meas. Guidance v03r05.
2. The RF output of EUT was connected to the spectrum analyzer by RF cable and attenuator. The path loss was compensated to the results for each measurement.
3. Set to the maximum power setting and enable the EUT transmit continuously.
4. Make the measurement with the spectrum analyzer's resolution bandwidth (RBW) = 100 kHz. Set the Video bandwidth (VBW) = 300 kHz. In order to make an accurate measurement. The 6 dB bandwidth must be greater than 500 kHz.
5. For 99% Bandwidth Measurement, the spectrum analyzer's resolution bandwidth (RBW) = 1MHz and set the Video bandwidth (VBW) = 3MHz.
6. Measure and record the results in the test report.

3.1.4 Test Setup

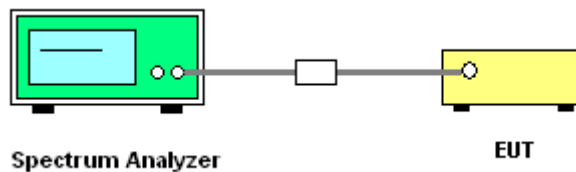



3.1.5 Test Result of 6dB and 99% Occupied Bandwidth

Please refer to Appendix A.

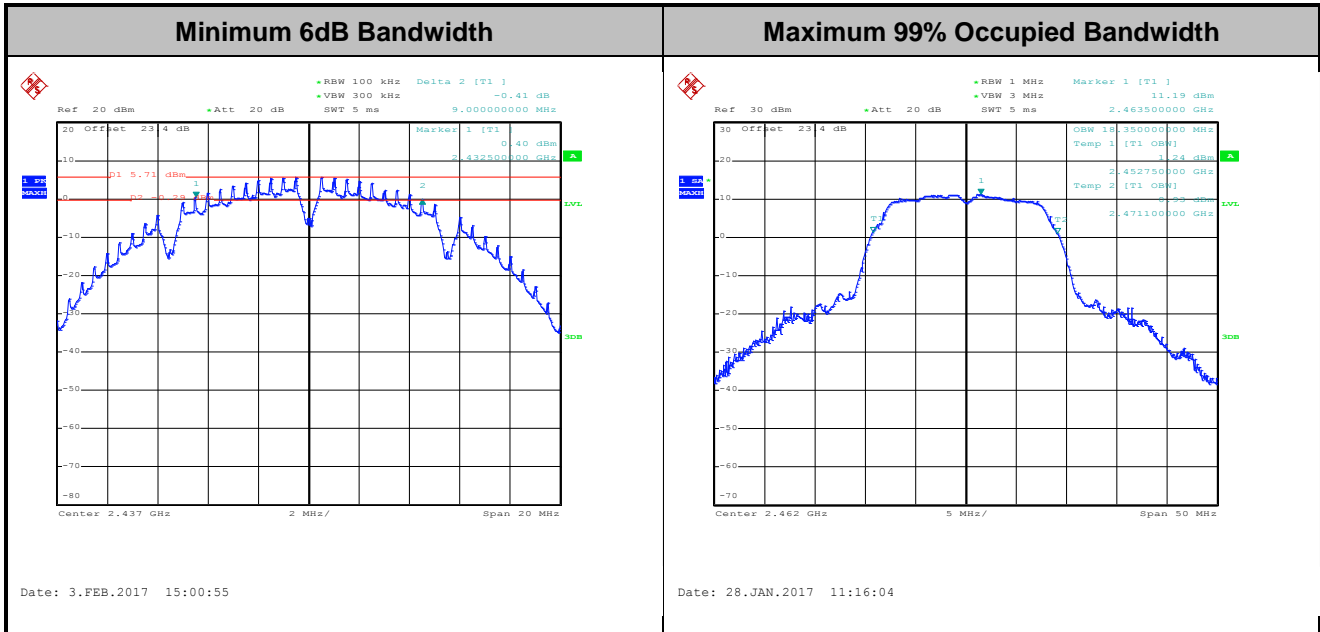

Note: The occupied channel bandwidth is maintained within the band of operation for all of the modulations.

3.2 Output Power Measurement

3.2.1 Limit of Output Power

For systems using digital modulation in the 2400-2483.5MHz, the limit for peak output power is 30dBm. If transmitting antenna of directional gain greater than 6dBi are used the peak output power from the intentional radiator shall be reduced below the above stated value by the amount in dB that the directional gain of the antenna exceeds 6 dBi. In case of point-to-point operation, the limit has to be reduced by 1dB for every 3dB that the directional gain of the antenna exceeds 6dBi.

3.2.2 Measuring Instruments

The measuring equipment is listed in the section 4 of this test report.

3.2.3 Test Procedures

1. The testing follows the Measurement Procedure of FCC KDB No. 558074 DTS D01 Meas. Guidance v03r05 section 9.1.2 PKPM1 Peak power meter method.
2. The RF output of EUT was connected to the power meter by RF cable and attenuator. The path loss was compensated to the results for each measurement.
3. Set to the maximum power setting and enable the EUT transmit continuously.
4. Measure the conducted output power and record the results in the test report.

3.2.4 Test Setup

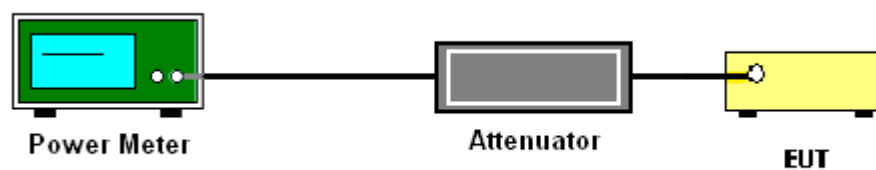

3.2.5 Test Result of Peak Output Power

Please refer to Appendix A.

3.2.6 Test Result of Average output Power (Reporting Only)

Please refer to Appendix A.

3.3 Power Spectral Density Measurement

3.3.1 Limit of Power Spectral Density

The peak power spectral density shall not be greater than 8dBm in any 3kHz band at any time interval of continuous transmission.

3.3.2 Measuring Instruments

The measuring equipment is listed in the section 4 of this test report.

3.3.3 Test Procedures

1. The testing follows Measurement Procedure 10.2 Method PKPSD of FCC KDB Publication No. 558074 D01 DTS Meas. Guidance v03r05
2. The RF output of EUT was connected to the spectrum analyzer by RF cable and attenuator. The path loss was compensated to the results for each measurement.
3. Set to the maximum power setting and enable the EUT transmit continuously.
4. Make the measurement with the spectrum analyzer's resolution bandwidth (RBW) = 3 kHz. Video bandwidth VBW = 10 kHz In order to make an accurate measurement, set the span to 1.5 times DTS Channel Bandwidth. (6dB BW)
5. Detector = peak, Sweep time = auto couple, Trace mode = max hold, Allow trace to fully stabilize. Use the peak marker function to determine the maximum power level.
6. Measure and record the results in the test report.

3.3.4 Test Setup

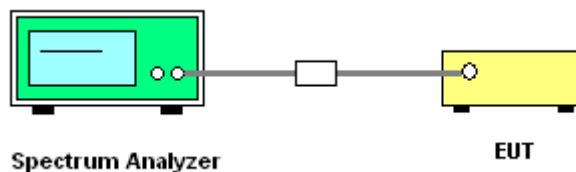



3.3.5 Test Result of Power Spectral Density

Please refer to Appendix A.

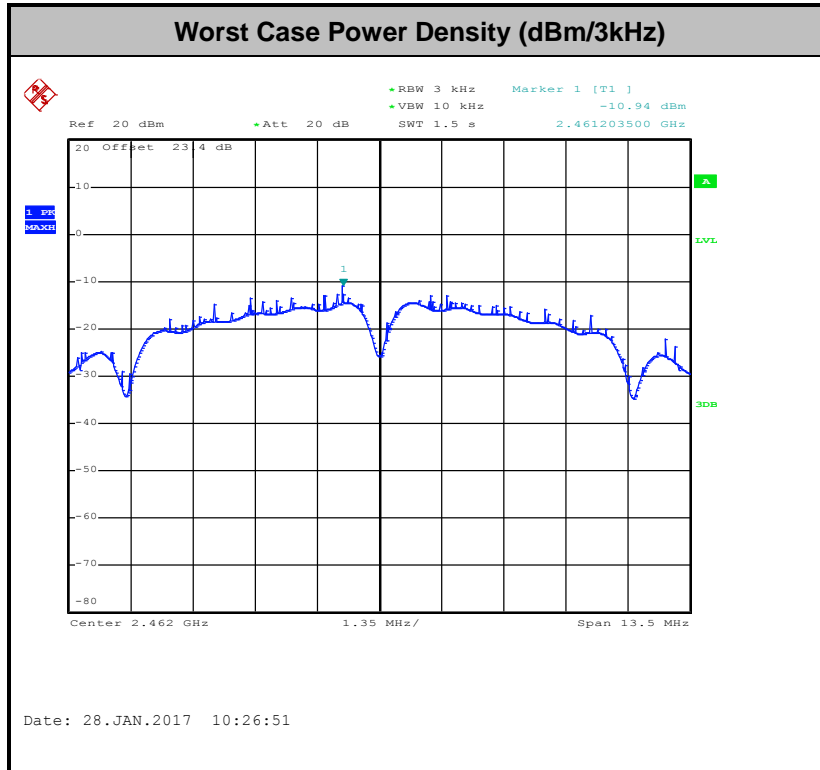

3.4 Conducted Band Edges and Spurious Emission Measurement

3.4.1 Limit of Conducted Band Edges and Spurious Emission Measurement

In any 100 kHz bandwidth outside of the authorized frequency band, the emissions which fall in the non-restricted bands shall be attenuated at least 20 dB / 30dB relative to the maximum PSD level in 100 kHz by RF conducted measurement and radiated emissions which fall in the restricted bands, as defined in Section 15.205(a), must also comply with the radiated emission limits specified in Section 15.209(a).

3.4.2 Measuring Instruments

The measuring equipment is listed in the section 4 of this test report.

3.4.3 Test Procedures

1. The testing follows FCC KDB Publication No. 558074 D01 DTS Meas. Guidance v03r05.
2. The RF output of EUT was connected to the spectrum analyzer by RF cable and attenuator. The path loss was compensated to the results for each measurement.
3. Set to the maximum power setting and enable the EUT transmit continuously.
4. Set RBW = 100 kHz, VBW=300 kHz, Peak Detector. Unwanted Emissions measured in any 100 kHz bandwidth outside of the authorized frequency band shall be attenuated by at least 20 dB relative to the maximum in-band peak PSD level in 100 kHz when maximum peak conducted output power procedure is used. If the transmitter complies with the conducted power limits based on the use of RMS averaging over a time interval, the attenuation required under this paragraph shall be 30 dB instead of 20 dB per 15.247(d).
5. Measure and record the results in the test report.
6. The RF fundamental frequency should be excluded against the limit line in the operating frequency band.

3.4.4 Test Setup

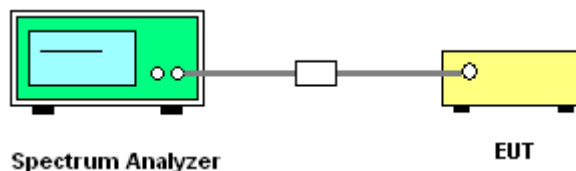



3.4.5 Test Result of Conducted Band Edges and Spurious Emission

Test Mode :	802.11b	Temperature :	21~25°C
Test Band :	2.4GHz Low	Relative Humidity :	51~54%
Test Channel :	01	Test Engineer :	Tommy Lee

WLAN 802.11b Channel 01

100kHz PSD reference Level

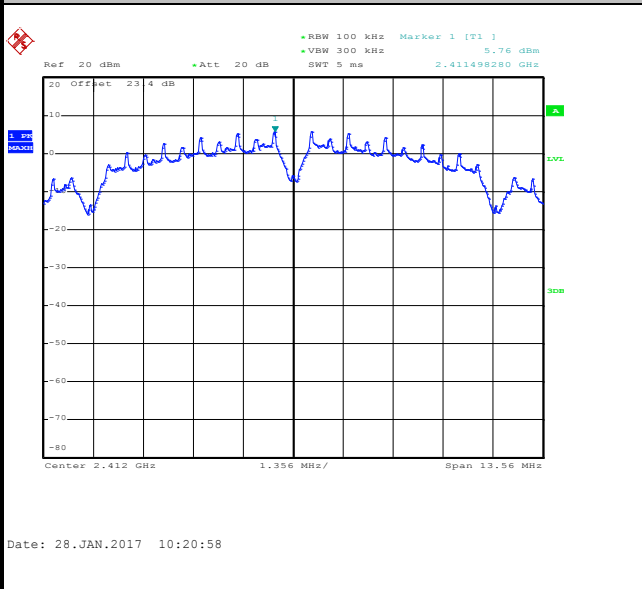

Low Channel Plot

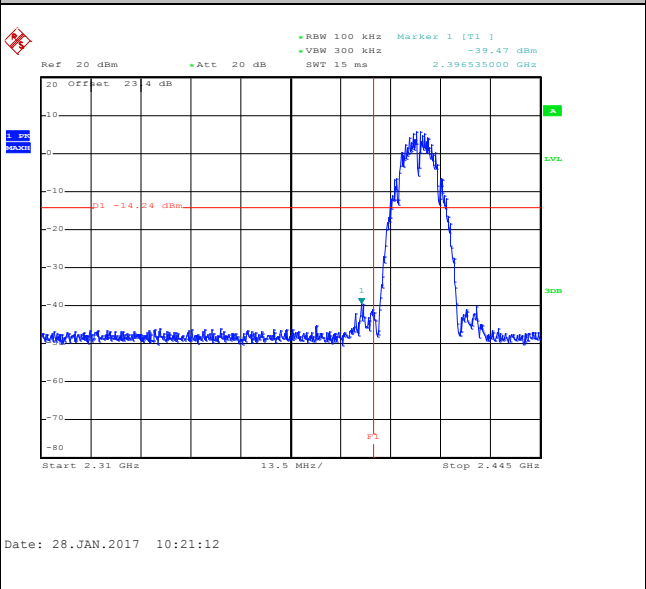

Spurious Emission 30MHz~3GHz

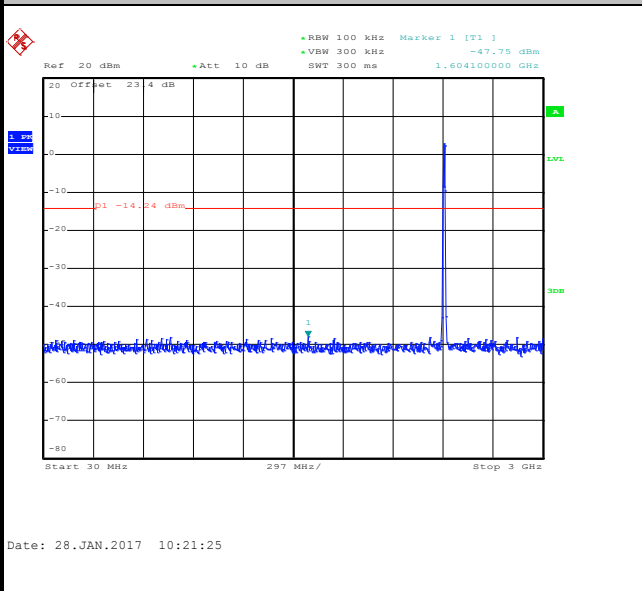

Spurious Emission 2GHz~25GHz

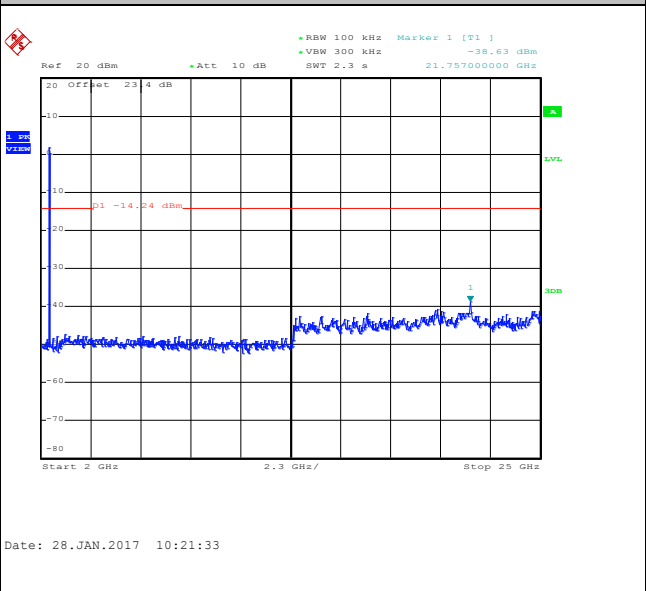



Test Mode :	802.11b	Temperature :	21~25°C
Test Band :	2.4GHz Mid	Relative Humidity :	51~54%
Test Channel :	06	Test Engineer :	Tommy Lee

WLAN 802.11b Channel 06

100kHz PSD reference Level

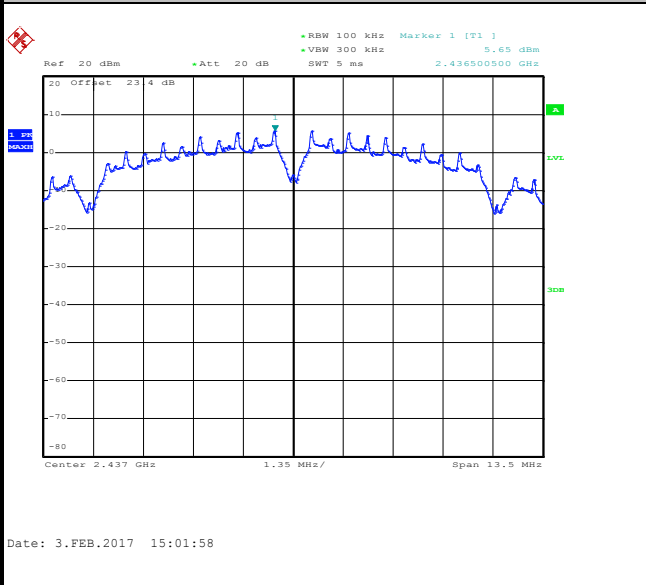

Spurious Emission 30MHz~3GHz

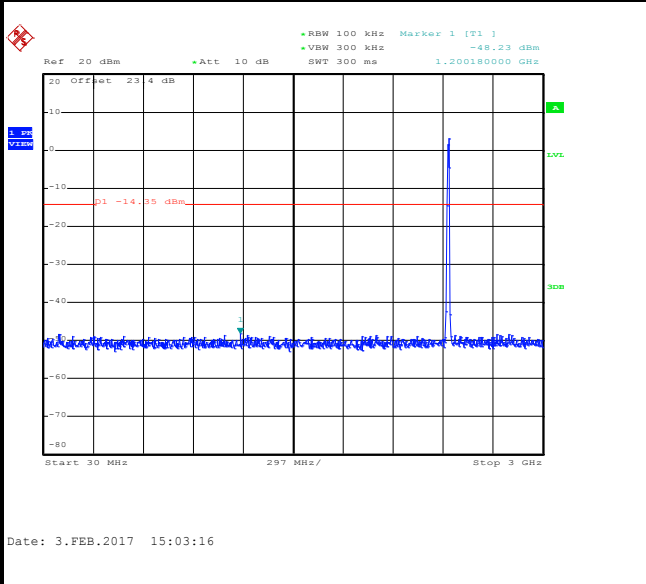

Spurious Emission 2GHz~25GHz

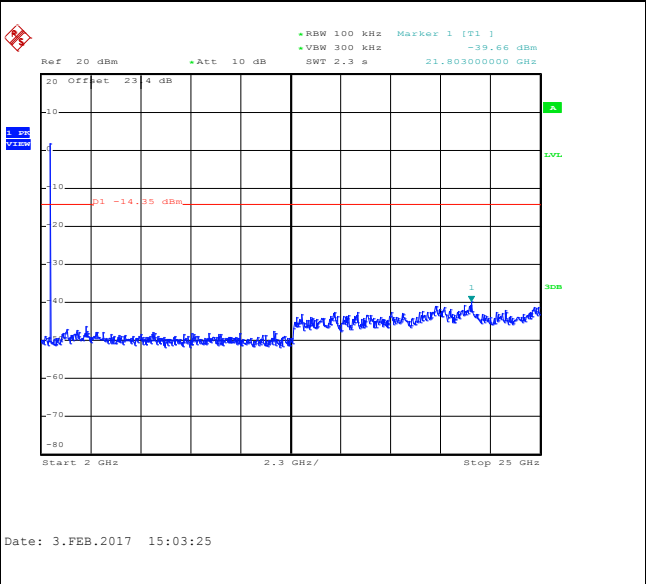



Test Mode :	802.11b	Temperature :	21~25°C
Test Band :	2.4GHz High	Relative Humidity :	51~54%
Test Channel :	11	Test Engineer :	Tommy Lee

WLAN 802.11b Channel 11

100kHz PSD reference Level

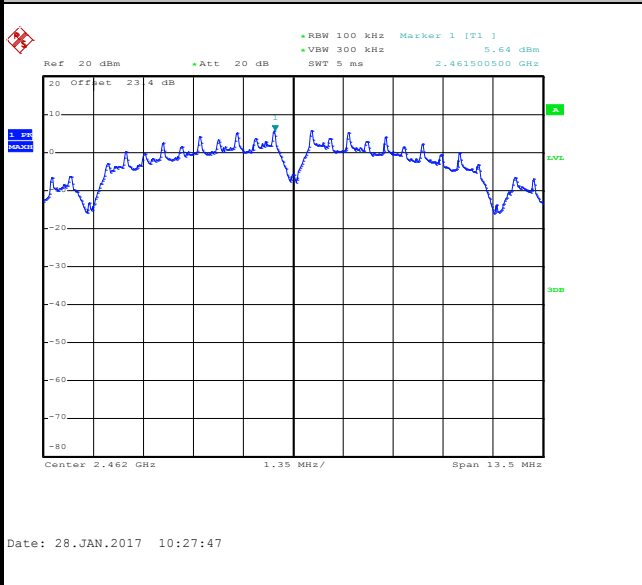

High Channel Plot

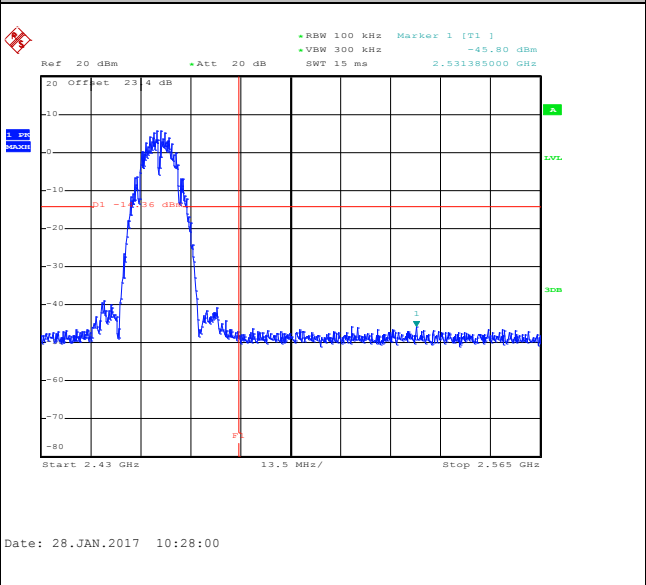

Spurious Emission 30MHz~3GHz

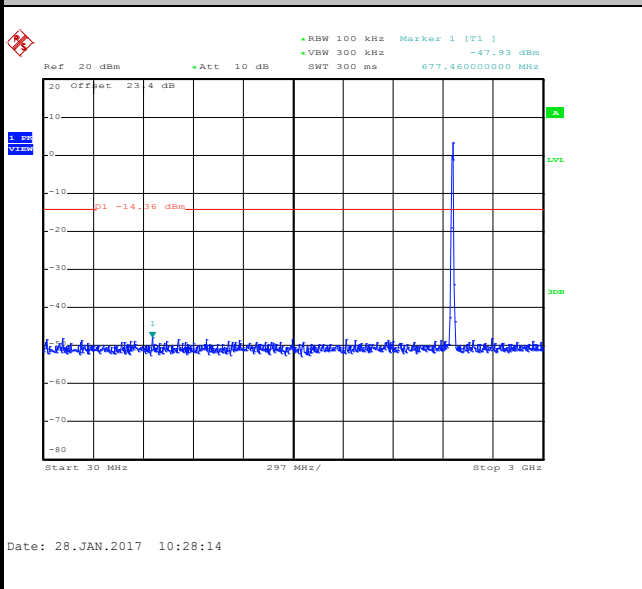

Spurious Emission 2GHz~25GHz

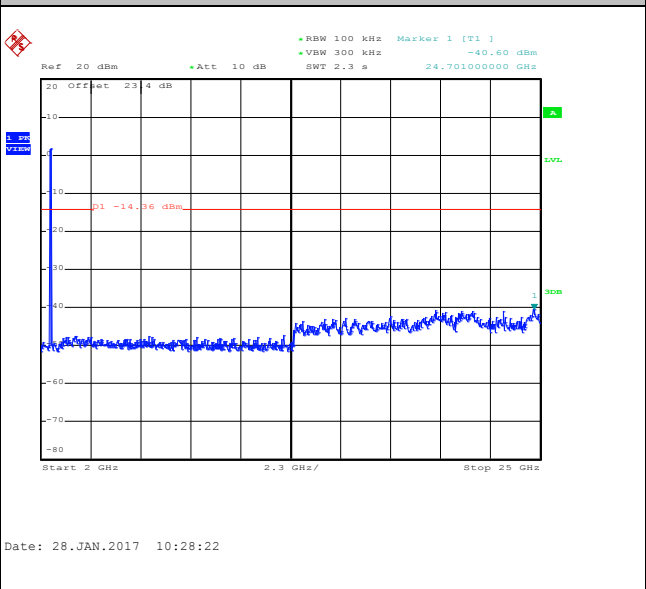



Test Mode :	802.11b	Temperature :	21~25°C
Test Band :	2.4GHz High	Relative Humidity :	51~54%
Test Channel :	12	Test Engineer :	Tommy Lee

WLAN 802.11b Channel 12

100kHz PSD reference Level

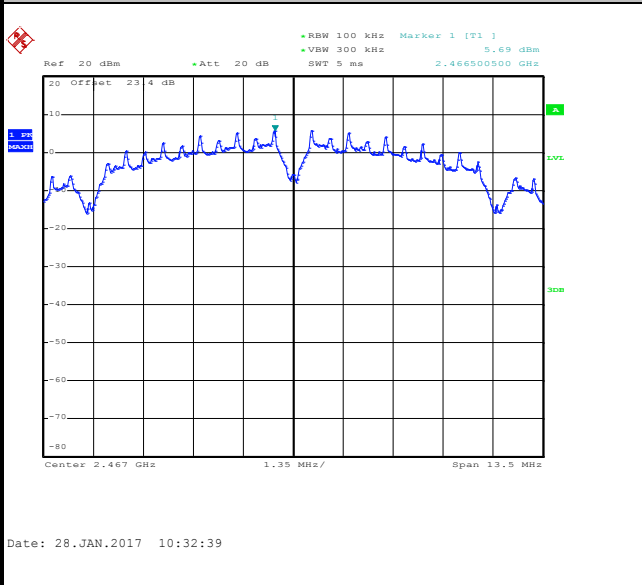

High Channel Plot

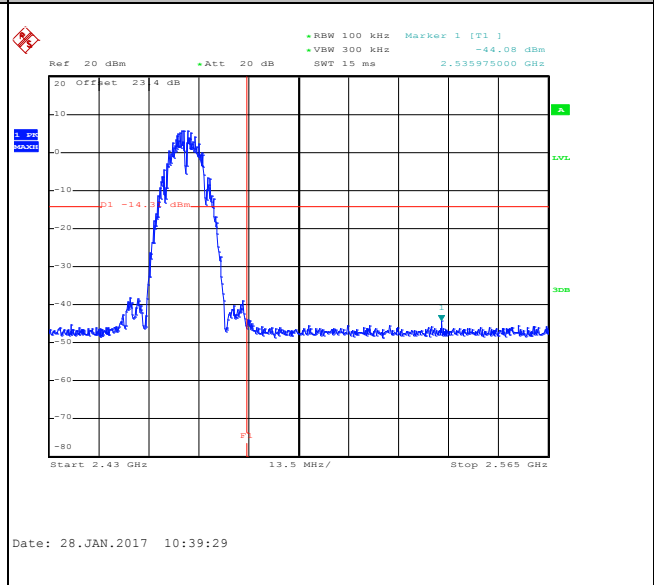

Spurious Emission 30MHz~3GHz

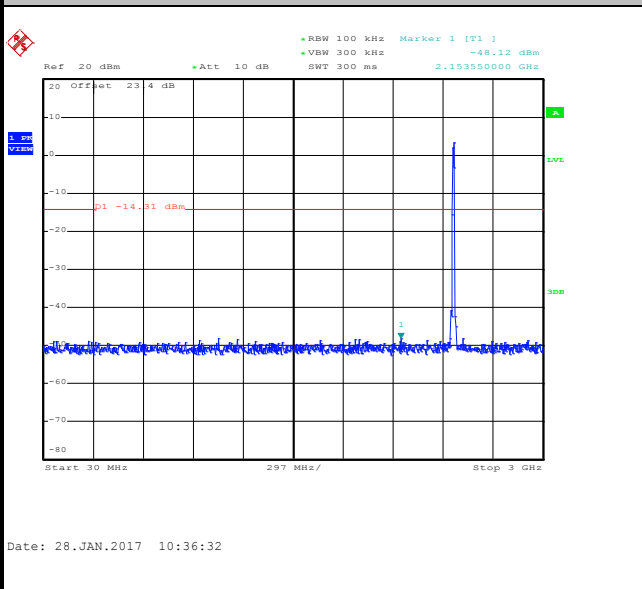

Spurious Emission 2GHz~25GHz

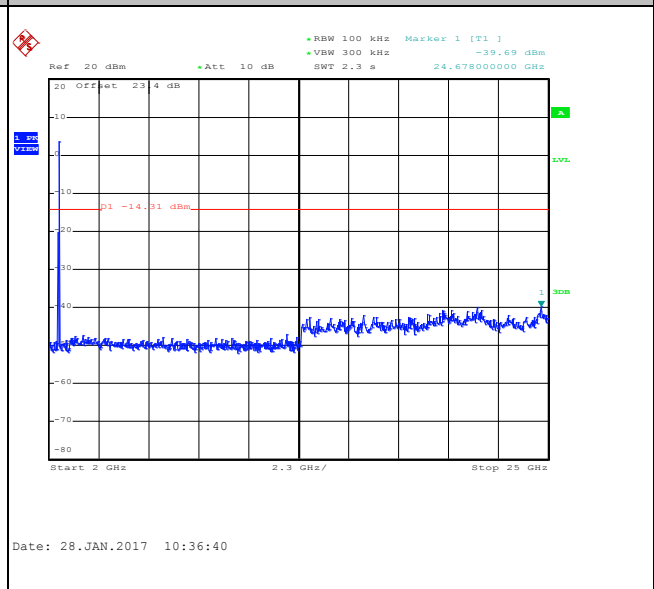



Test Mode :	802.11b	Temperature :	21~25°C
Test Band :	2.4GHz High	Relative Humidity :	51~54%
Test Channel :	13	Test Engineer :	Tommy Lee

WLAN 802.11b Channel 13

100kHz PSD reference Level

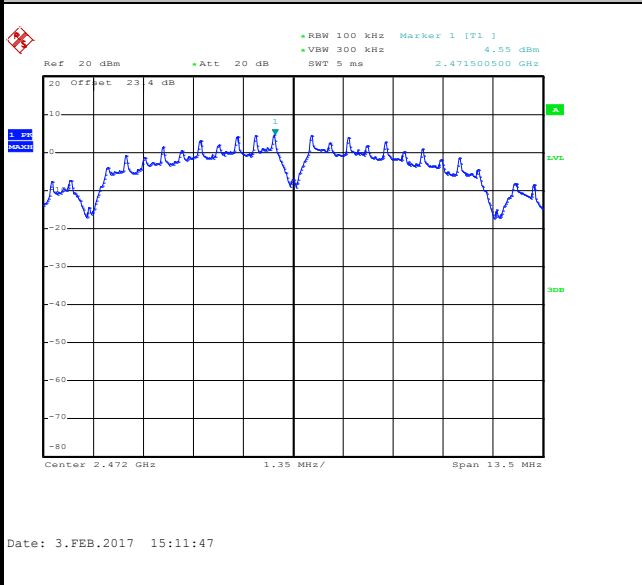

High Channel Plot

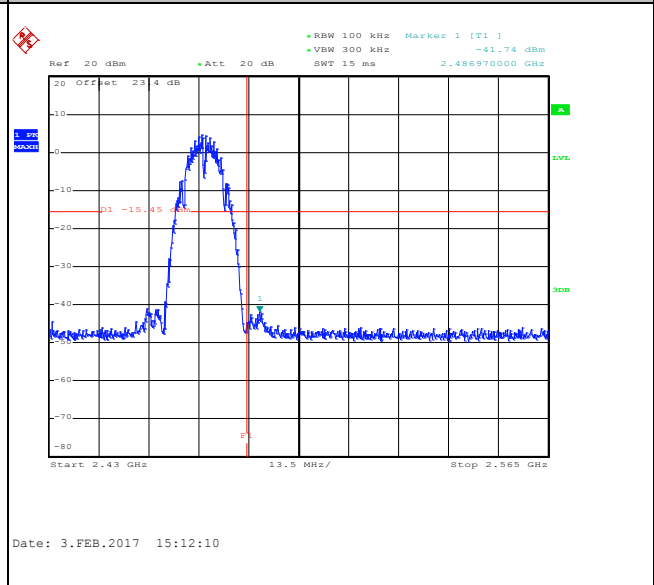

Spurious Emission 30MHz~3GHz

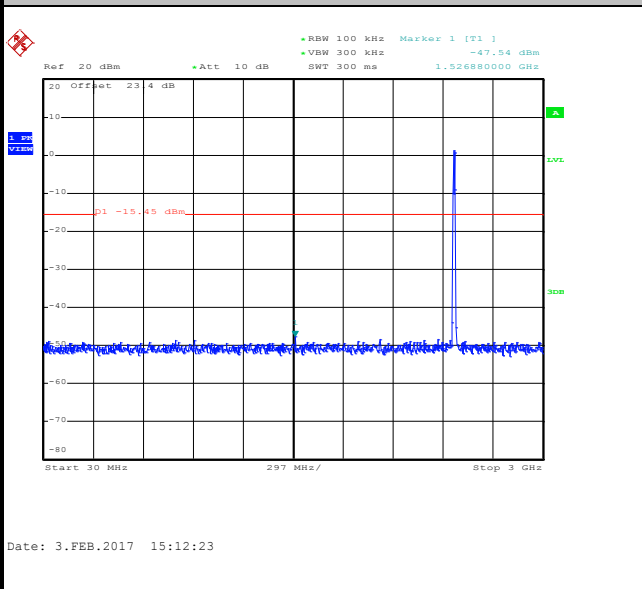

Spurious Emission 2GHz~25GHz

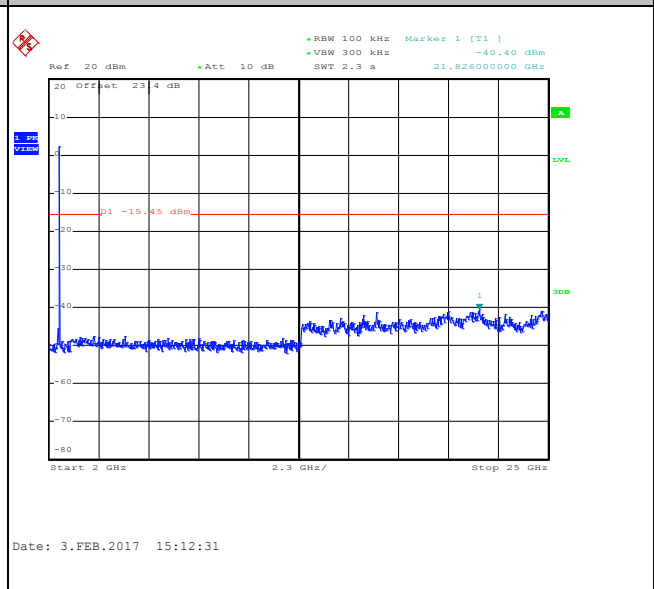



Test Mode :	802.11g	Temperature :	21~25°C
Test Band :	2.4GHz Low	Relative Humidity :	51~54%
Test Channel :	01	Test Engineer :	Tommy Lee

WLAN 802.11g Channel 01

100kHz PSD reference Level

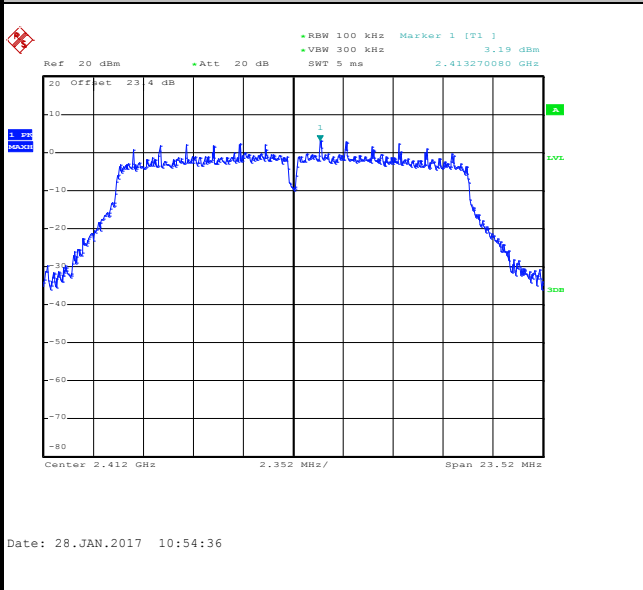

Low Channel Plot

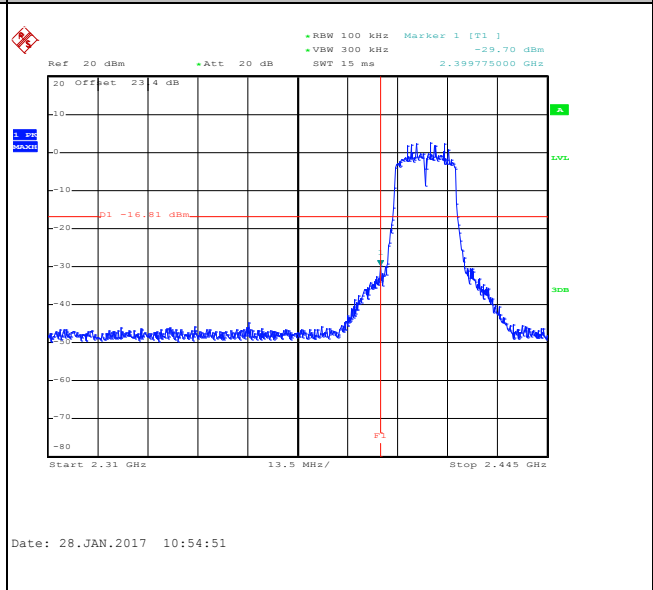

Spurious Emission 30MHz~3GHz

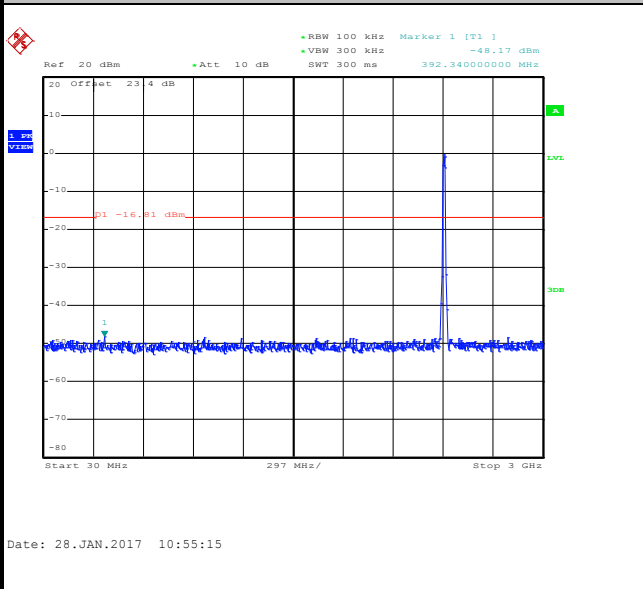

Spurious Emission 2GHz~25GHz

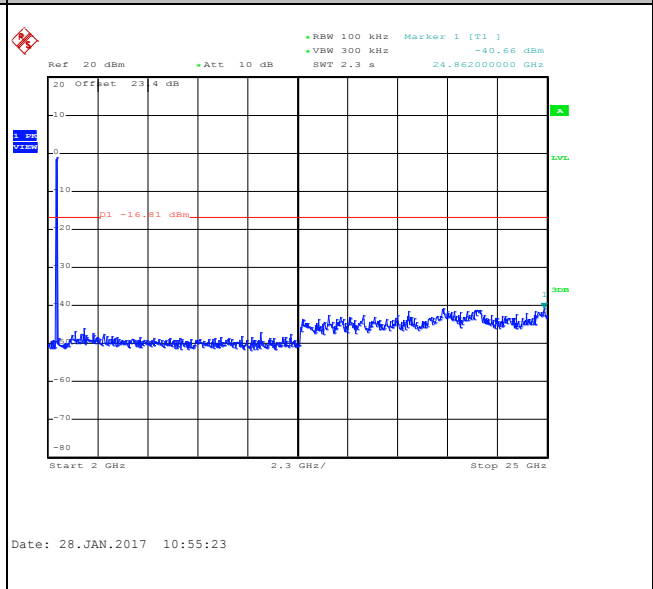



Test Mode :	802.11g	Temperature :	21~25°C
Test Band :	2.4GHz Mid	Relative Humidity :	51~54%
Test Channel :	06	Test Engineer :	Tommy Lee

WLAN 802.11g Channel 06

100kHz PSD reference Level

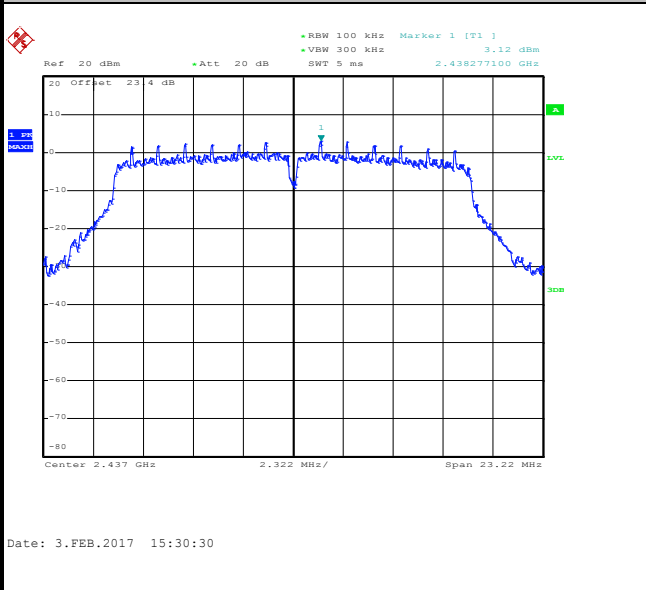

Spurious Emission 30MHz~3GHz

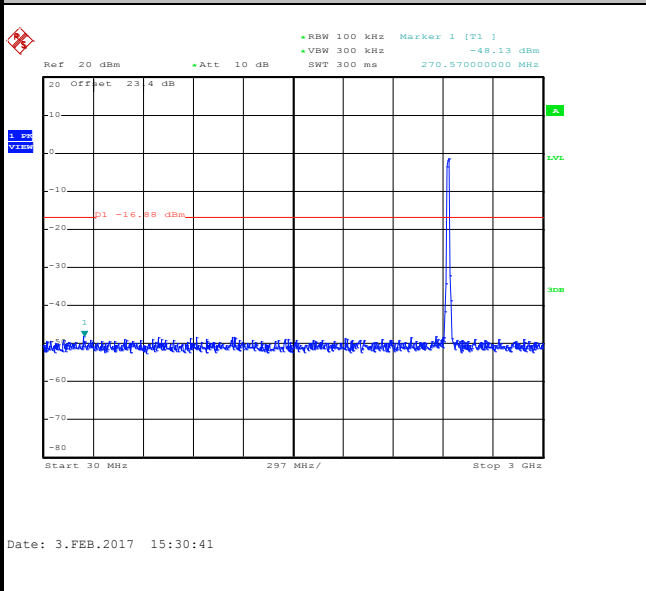

Spurious Emission 2GHz~25GHz

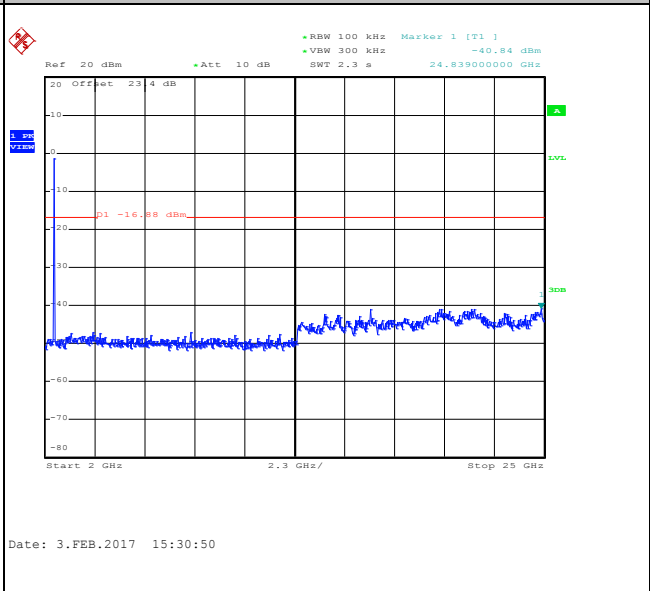



Test Mode :	802.11g	Temperature :	21~25°C
Test Band :	2.4GHz High	Relative Humidity :	51~54%
Test Channel :	11	Test Engineer :	Tommy Lee

WLAN 802.11g Channel 11

100kHz PSD reference Level

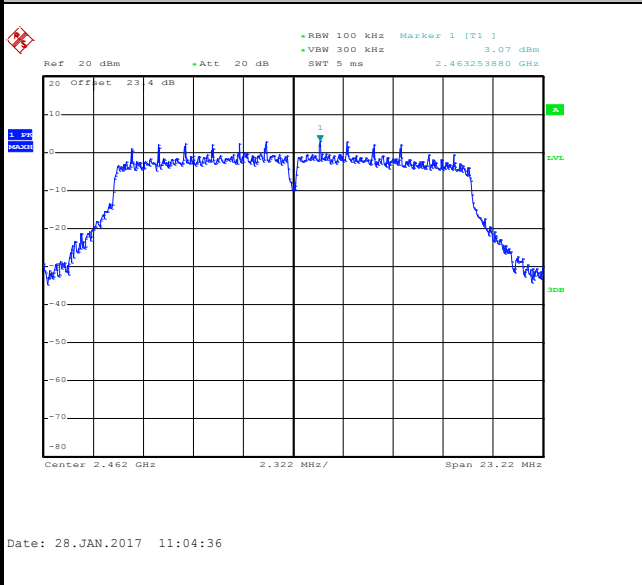

High Channel Plot

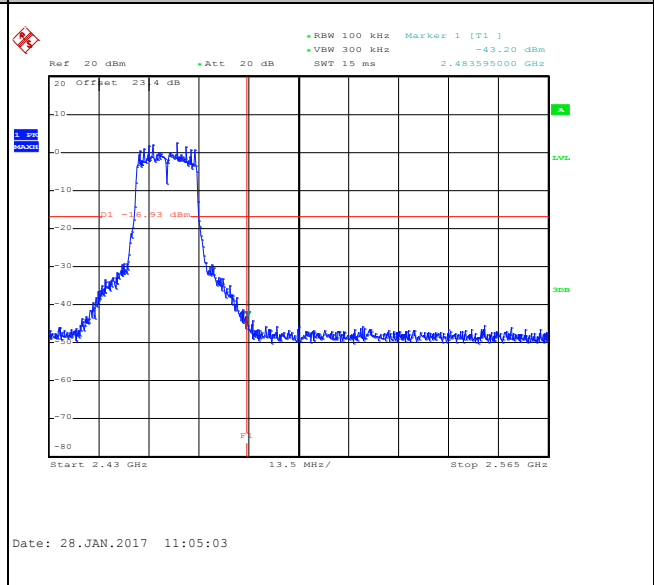

Spurious Emission 30MHz~3GHz

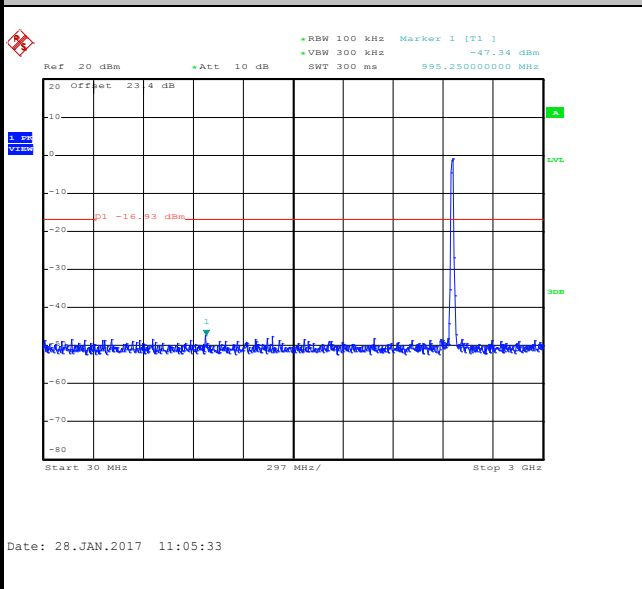

Spurious Emission 2GHz~25GHz

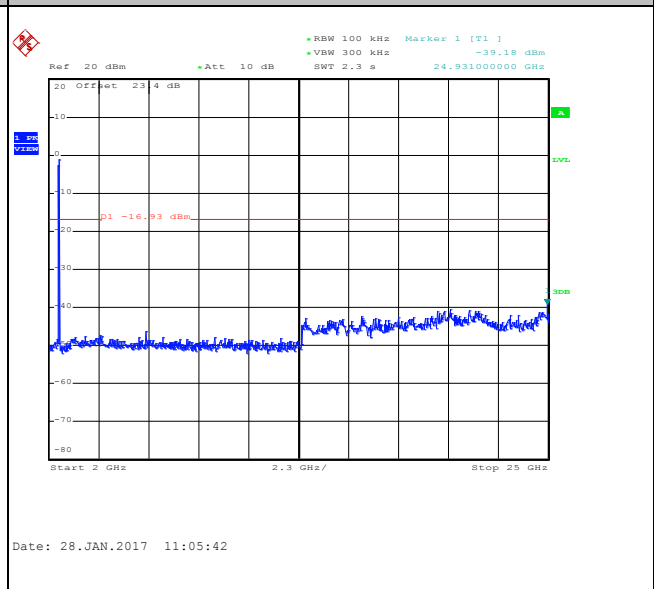



Test Mode :	802.11g	Temperature :	21~25°C
Test Band :	2.4GHz High	Relative Humidity :	51~54%
Test Channel :	12	Test Engineer :	Tommy Lee

WLAN 802.11g Channel 12

100kHz PSD reference Level

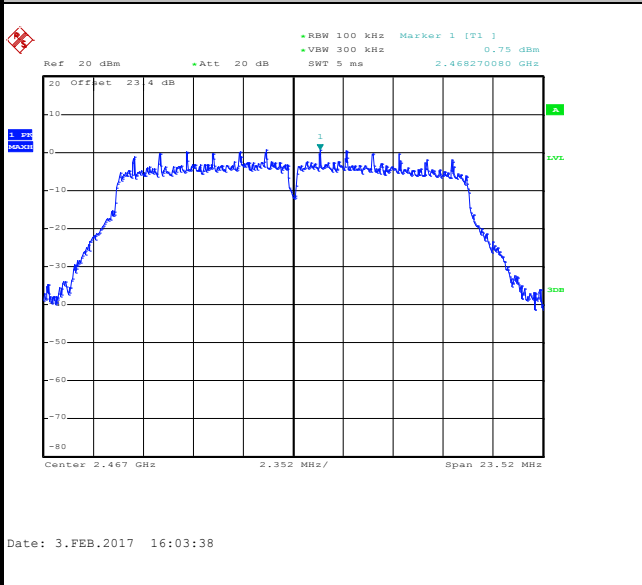

High Channel Plot

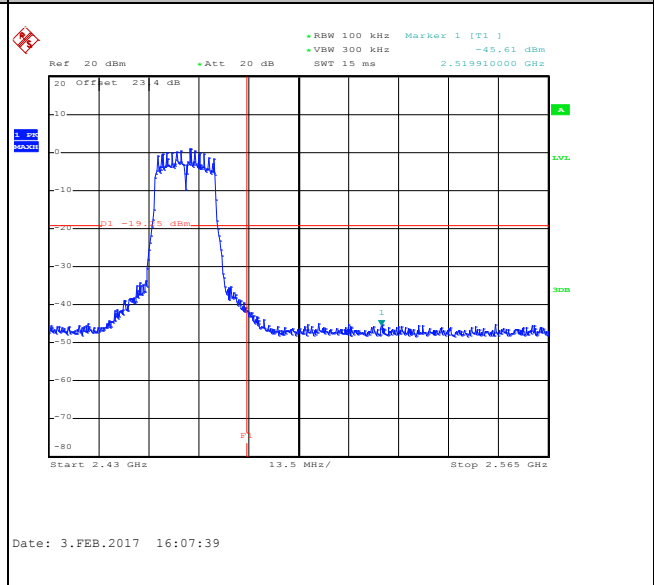

Spurious Emission 30MHz~3GHz

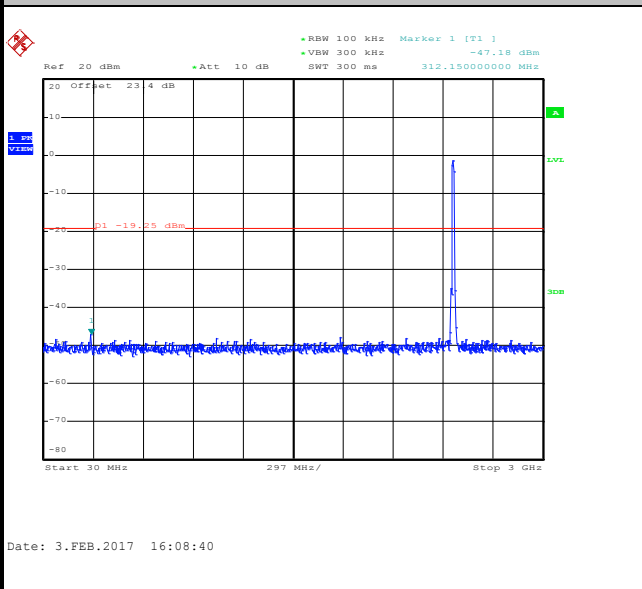

Spurious Emission 2GHz~25GHz

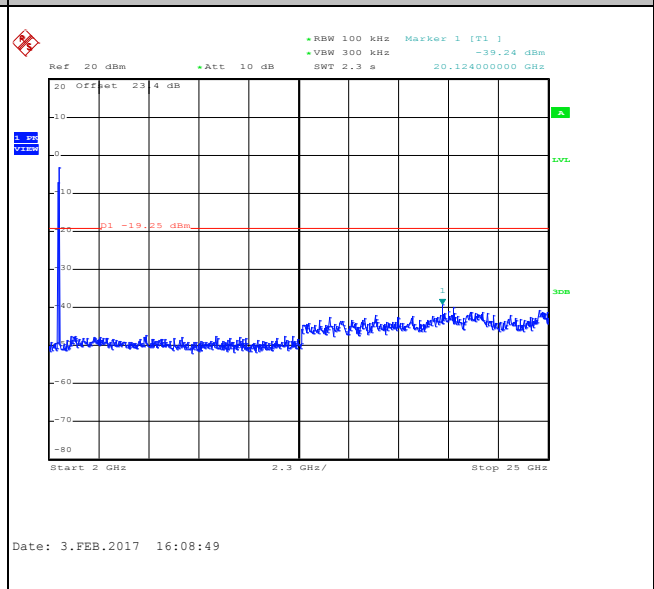



Test Mode :	802.11g	Temperature :	21~25°C
Test Band :	2.4GHz High	Relative Humidity :	51~54%
Test Channel :	13	Test Engineer :	Tommy Lee

WLAN 802.11g Channel 13

100kHz PSD reference Level

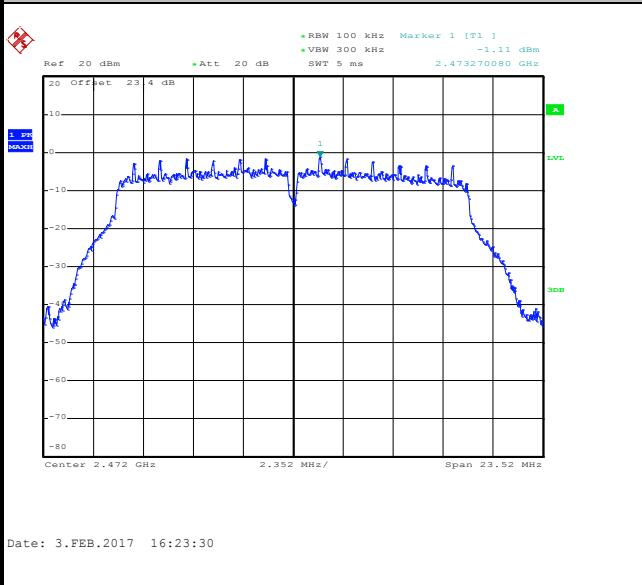

High Channel Plot

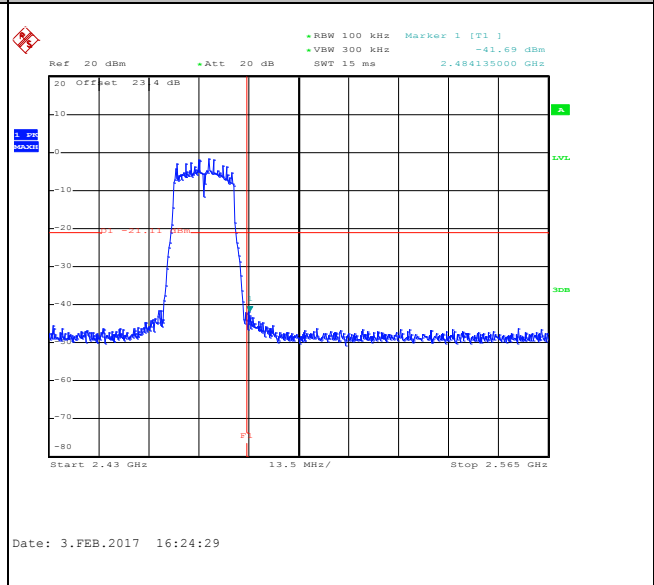

Spurious Emission 30MHz~3GHz

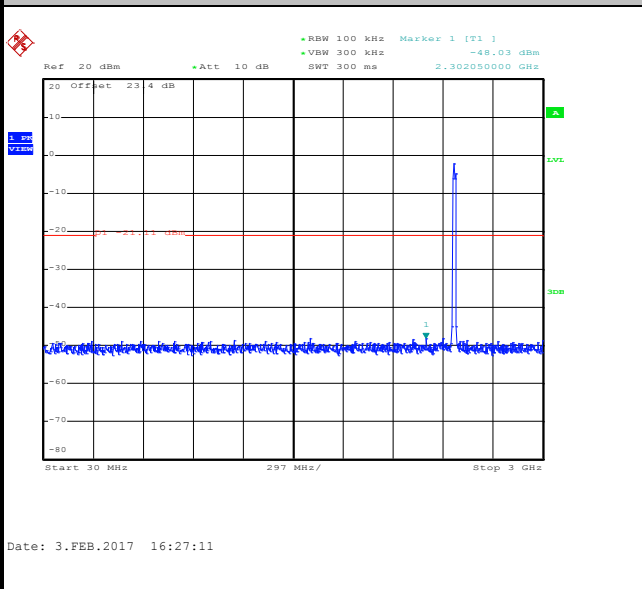

Spurious Emission 2GHz~25GHz

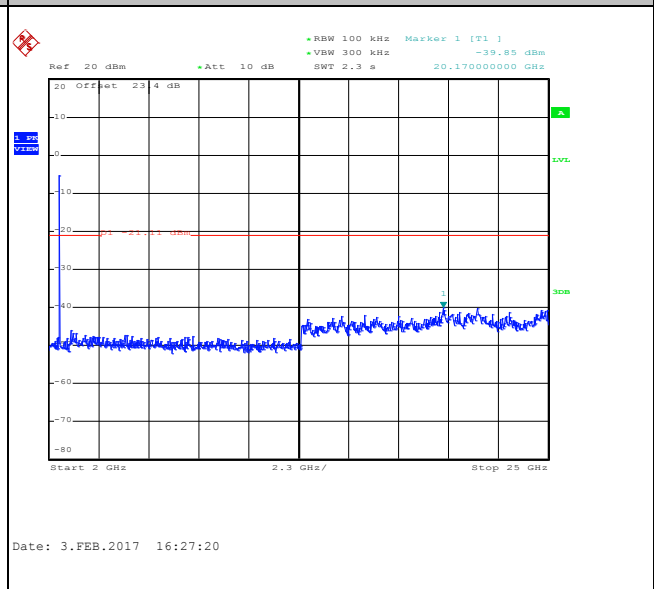



Test Mode :	802.11n HT20	Temperature :	21~25°C
Test Band :	2.4GHz Low	Relative Humidity :	51~54%
Test Channel :	01	Test Engineer :	Tommy Lee

WLAN 802.11n HT20 Channel 01

100kHz PSD reference Level

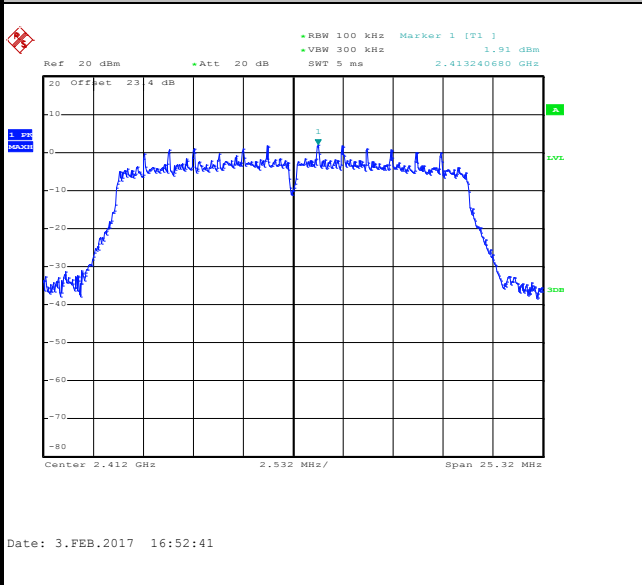

Low Channel Plot

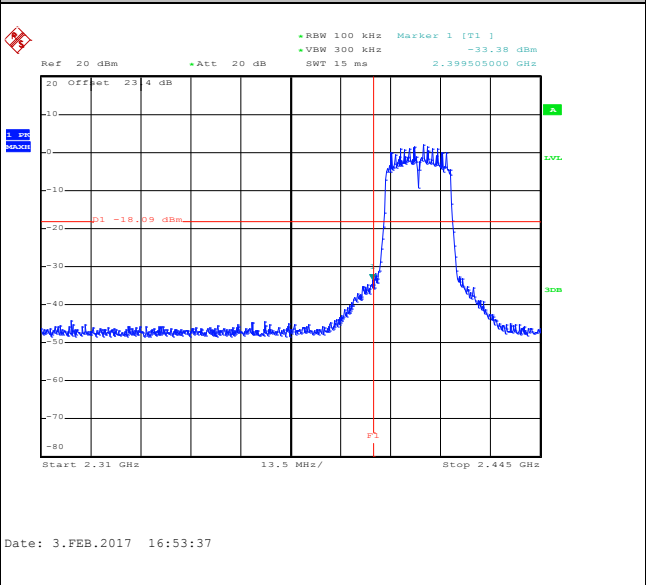

Spurious Emission 30MHz~3GHz

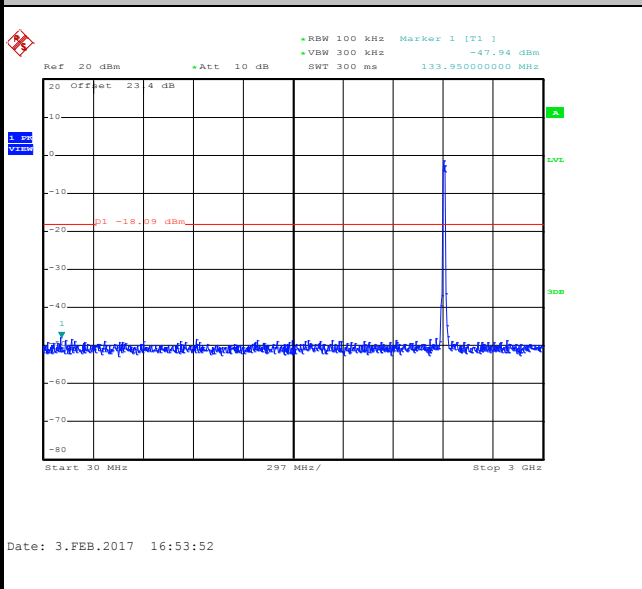

Spurious Emission 2GHz~25GHz

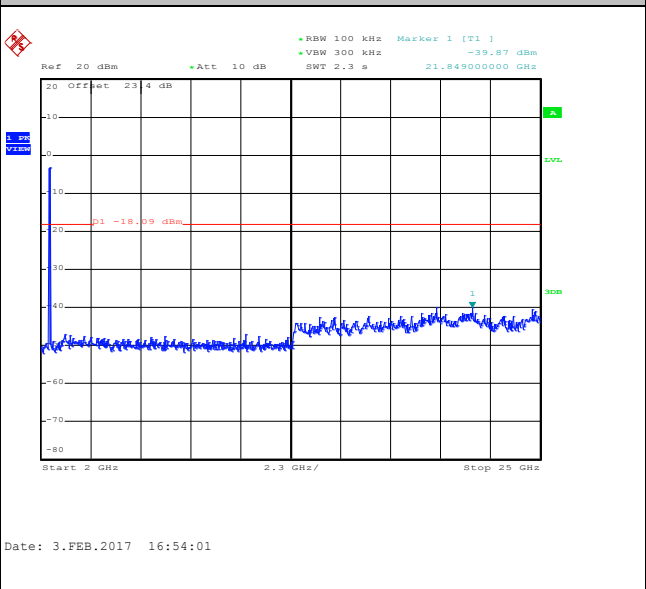



Test Mode :	802.11n HT20	Temperature :	21~25°C
Test Band :	2.4GHz Mid	Relative Humidity :	51~54%
Test Channel :	06	Test Engineer :	Tommy Lee

WLAN 802.11n HT20 Channel 06

100kHz PSD reference Level

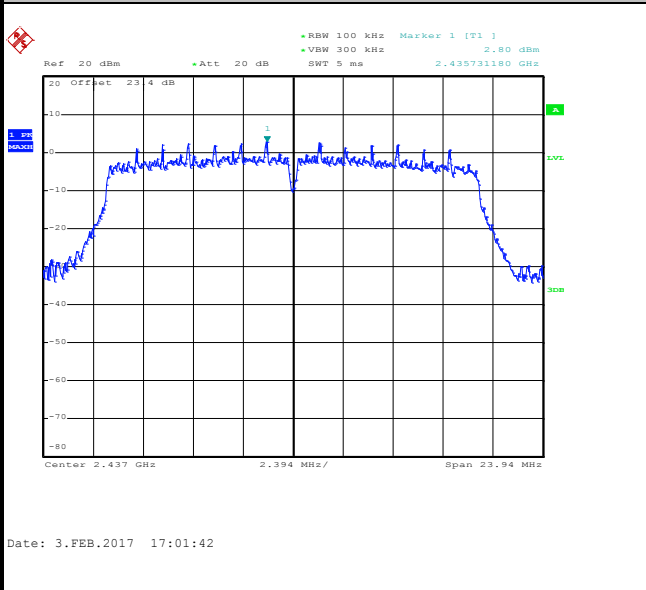

Spurious Emission 30MHz~3GHz

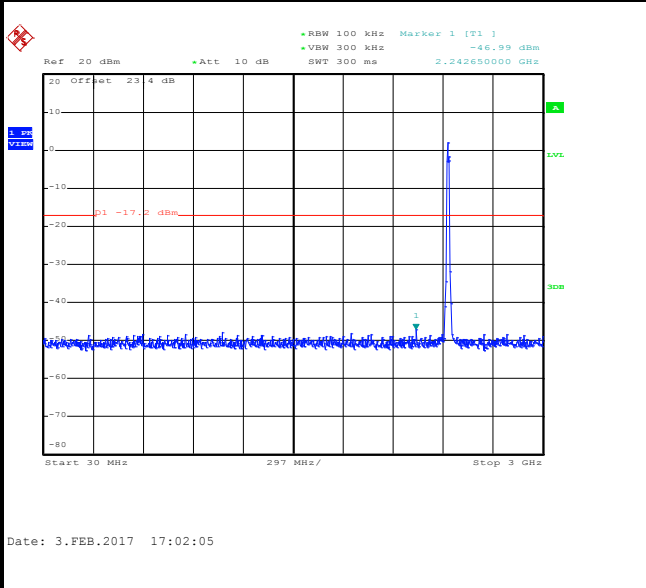

Spurious Emission 2GHz~25GHz

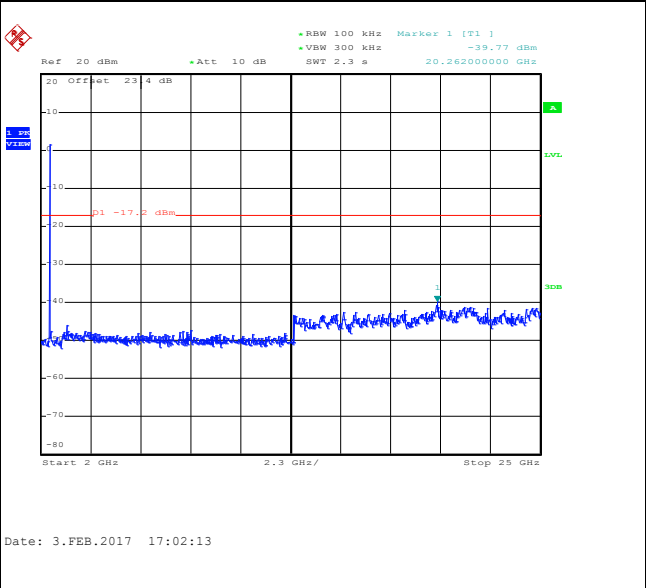



Test Mode :	802.11n HT20	Temperature :	21~25°C
Test Band :	2.4GHz High	Relative Humidity :	51~54%
Test Channel :	11	Test Engineer :	Tommy Lee

WLAN 802.11n HT20 Channel 11

100kHz PSD reference Level

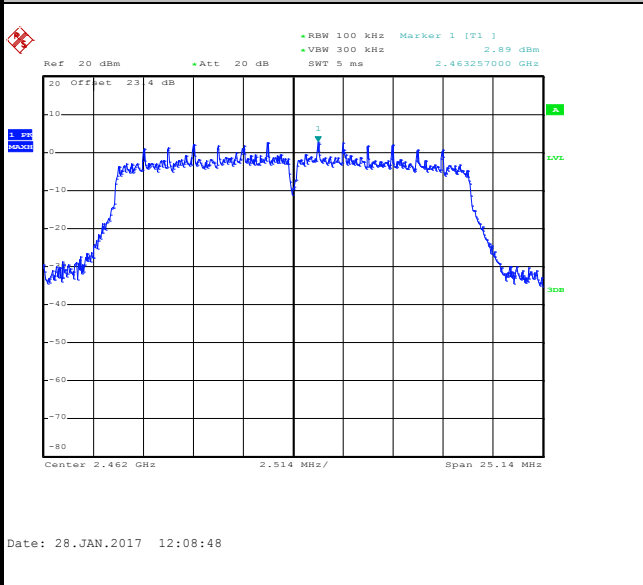

High Channel Plot

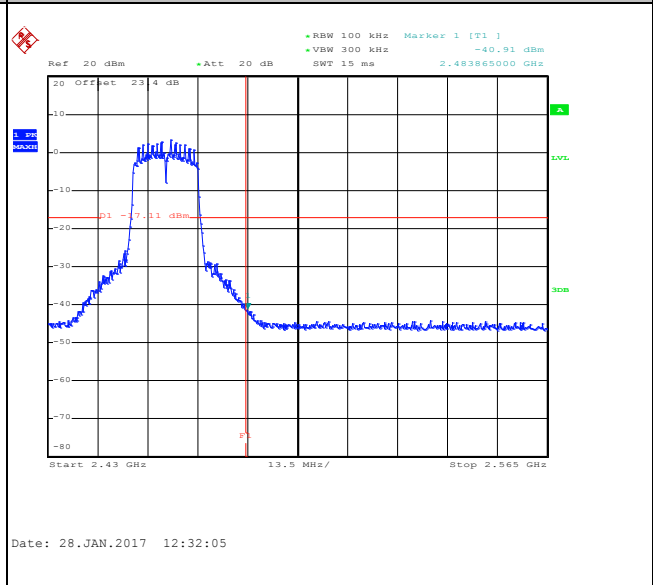

Spurious Emission 30MHz~3GHz

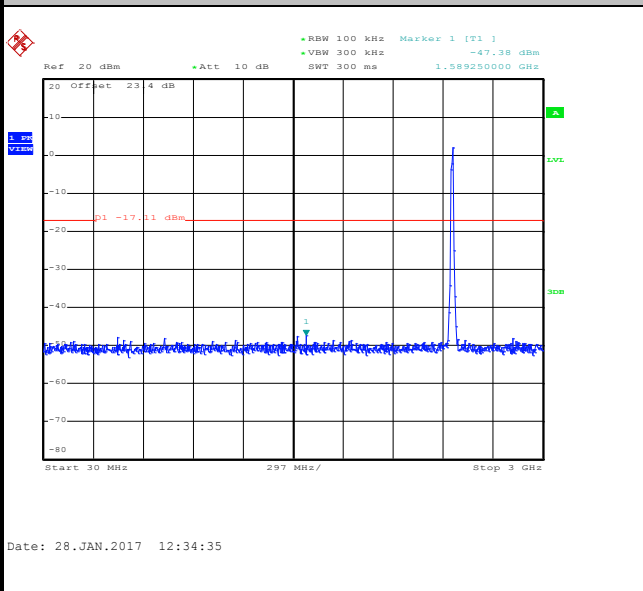

Spurious Emission 2GHz~25GHz

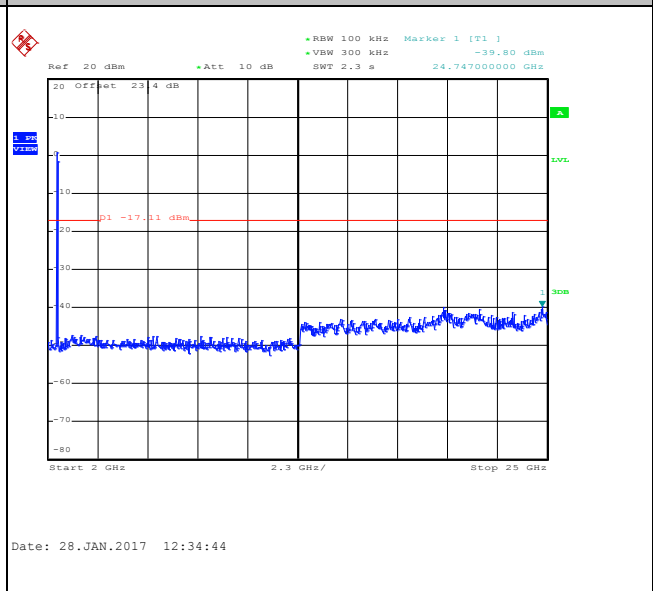



Test Mode :	802.11n HT20	Temperature :	21~25°C
Test Band :	2.4GHz High	Relative Humidity :	51~54%
Test Channel :	12	Test Engineer :	Tommy Lee

WLAN 802.11n HT20 Channel 12

100kHz PSD reference Level

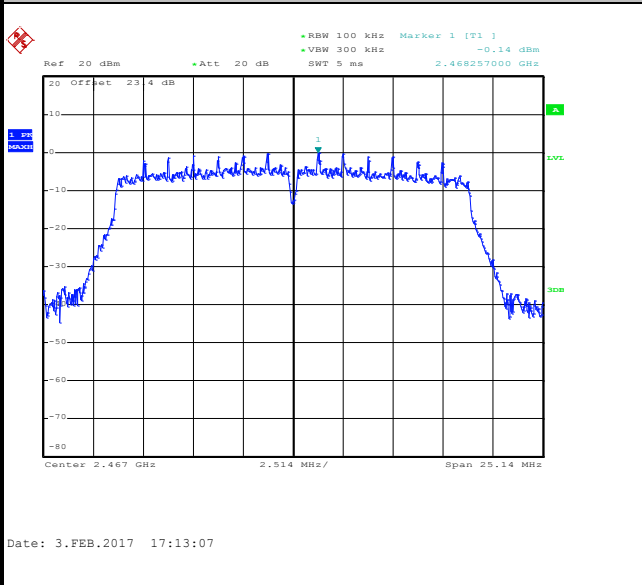

High Channel Plot

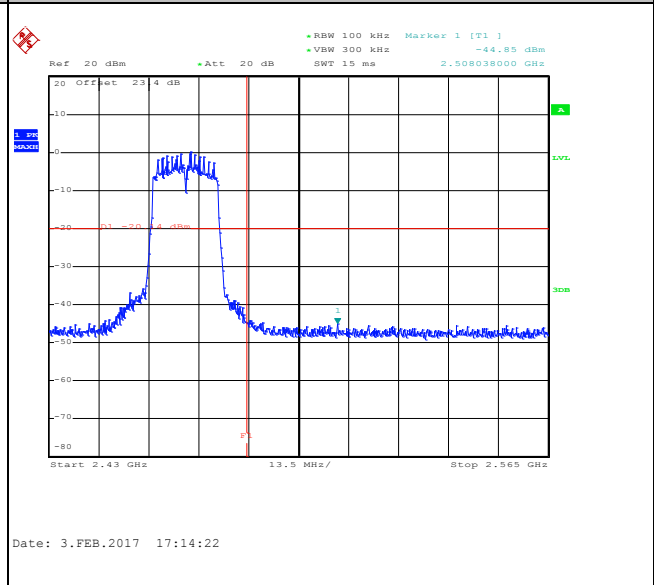

Spurious Emission 30MHz~3GHz

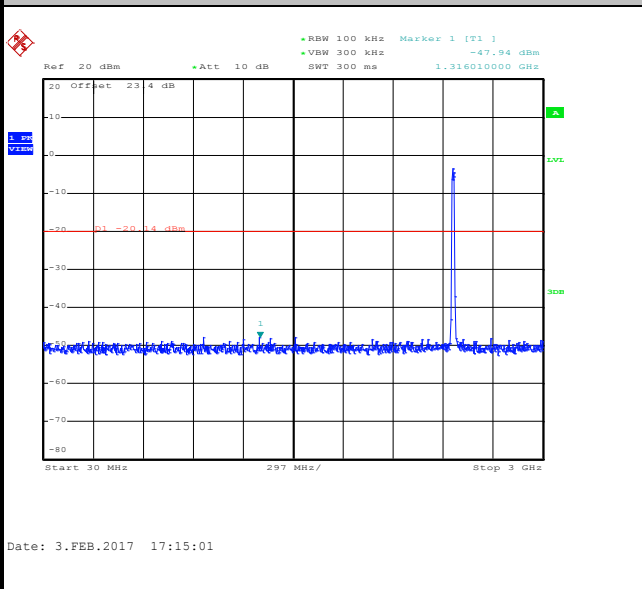

Spurious Emission 2GHz~25GHz

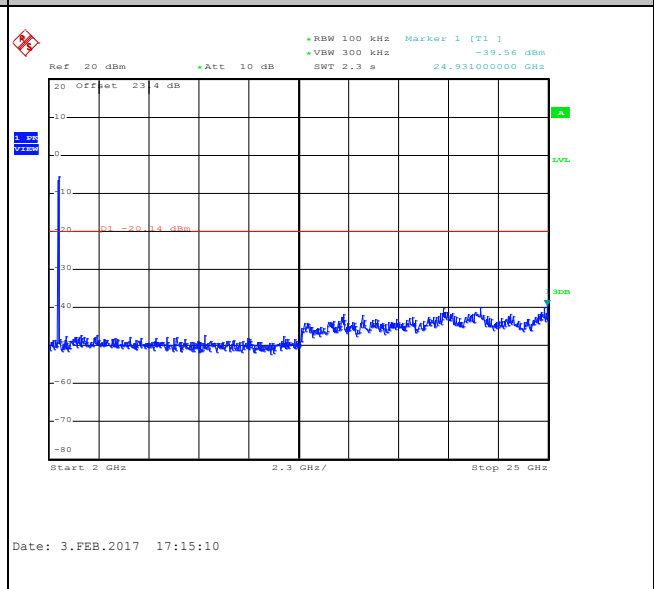



Test Mode :	802.11n HT20	Temperature :	21~25°C
Test Band :	2.4GHz High	Relative Humidity :	51~54%
Test Channel :	13	Test Engineer :	Tommy Lee

WLAN 802.11n HT20 Channel 13

100kHz PSD reference Level

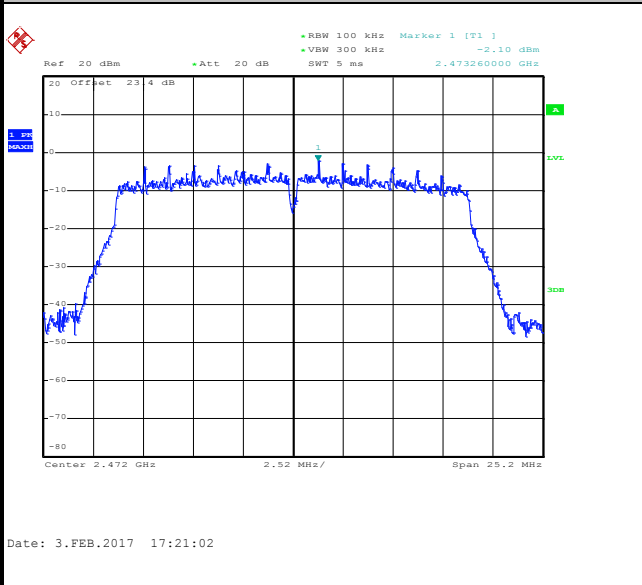

High Channel Plot

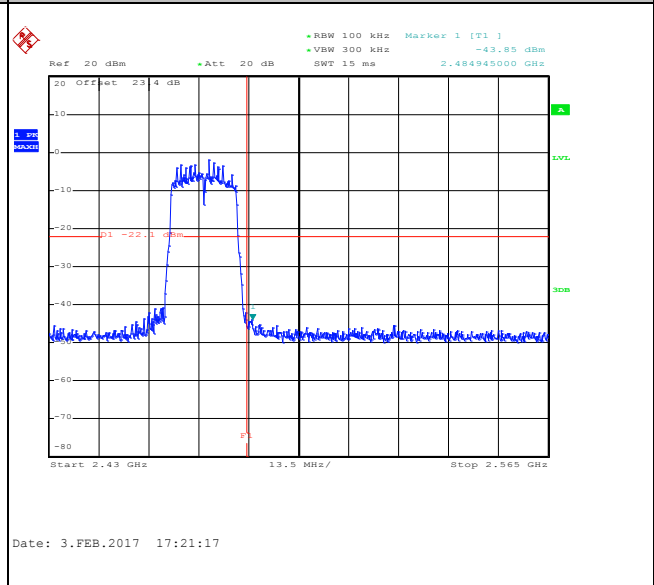

Spurious Emission 30MHz~3GHz

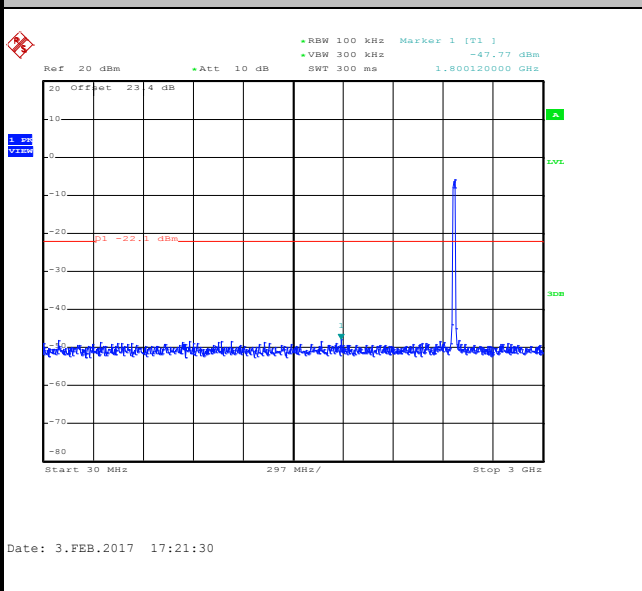

Spurious Emission 2GHz~25GHz

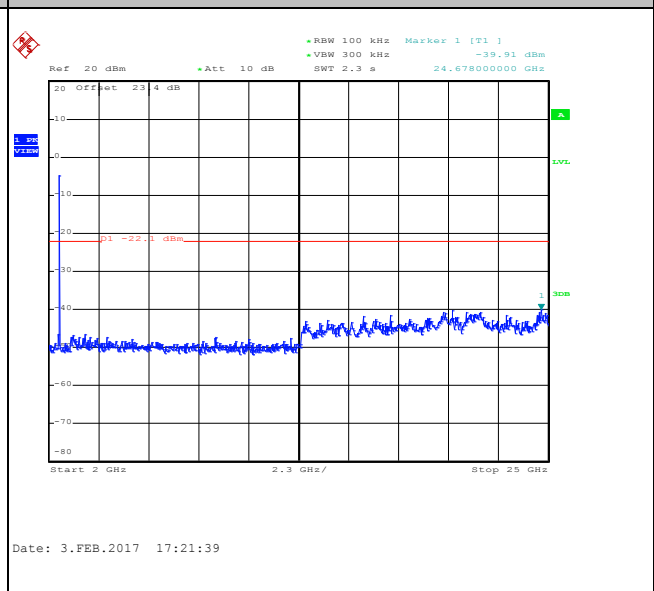



3.5 Radiated Band Edges and Spurious Emission Measurement

3.5.1 Limit of Radiated band edge and Spurious Emission Measurement

In any 100 kHz bandwidth outside the intentional radiator frequency band, all harmonics/spurious must be at least 20 dB below the highest emission level within the authorized band. If the output power of this device was measured by spectrum analyzer, the attenuation under this paragraph shall be 30 dB instead of 20 dB. In addition, radiated emissions which fall in the restricted bands must also comply with the FCC section 15.209 limits as below.

Frequency (MHz)	Field Strength (microvolts/meter)	Measurement Distance (meters)
0.009 – 0.490	2400/F(kHz)	300
0.490 – 1.705	24000/F(kHz)	30
1.705 – 30.0	30	30
30 – 88	100	3
88 – 216	150	3
216 - 960	200	3
Above 960	500	3

3.5.2 Measuring Instruments

The measuring equipment is listed in the section 4 of this test report.



3.5.3 Test Procedures

1. The testing follows FCC KDB Publication No. 558074 D01 DTS Meas. Guidance v03r05.
2. The EUT was arranged to its worst case and then tune the antenna tower (from 1 m to 4 m) and turntable (from 0 degree to 360 degrees) to find the maximum reading. A pre-amp and a high pass filter are used for the test in order to get better signal level.
3. The EUT was placed on a turntable with 0.8 meter for frequency below 1GHz and 1.5 meter for frequency above 1GHz respectively above ground.
4. The EUT was set 3 meters from the interference receiving antenna, which was mounted on the top of a variable height antenna tower.
5. Corrected Reading: Antenna Factor + Cable Loss + Read Level - Preamp Factor = Level
6. For measurement below 1GHz, If the emission level of the EUT measured by the peak detector is 3 dB lower than the applicable limit, the peak emission level will be reported. Otherwise, the emission measurement will be repeated using the quasi-peak detector and reported.
7. Use the following spectrum analyzer settings:
 - (1) Span shall wide enough to fully capture the emission being measured;
 - (2) Set RBW=100 kHz for $f < 1$ GHz; VBW \geq RBW; Sweep = auto; Detector function = peak; Trace = max hold;
 - (3) Set RBW = 1 MHz, VBW= 3MHz for $f \geq 1$ GHz for peak measurement.
For average measurement:
 - VBW = 10 Hz, when duty cycle is no less than 98 percent.
 - VBW $\geq 1/T$, when duty cycle is less than 98 percent where T is the minimum transmission duration over which the transmitter is on and is transmitting at its maximum power control level for the tested mode of operation.

3.5.4 Test Setup

For radiated emissions below 30MHz

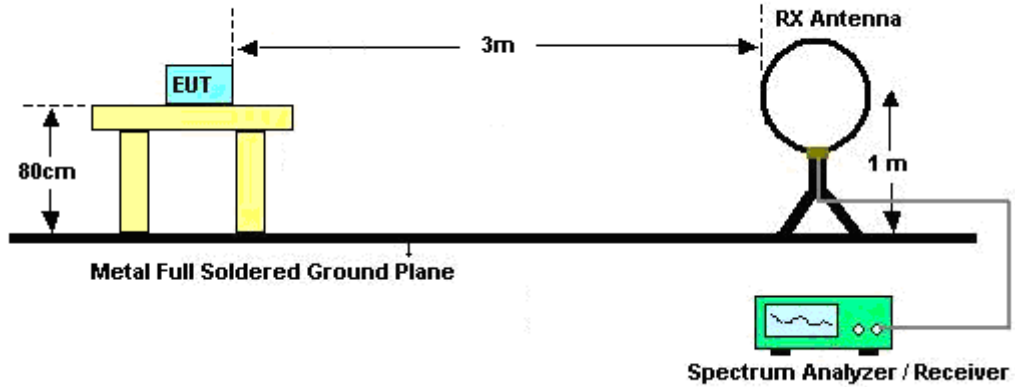

For radiated emissions from 30MHz to 1GHz

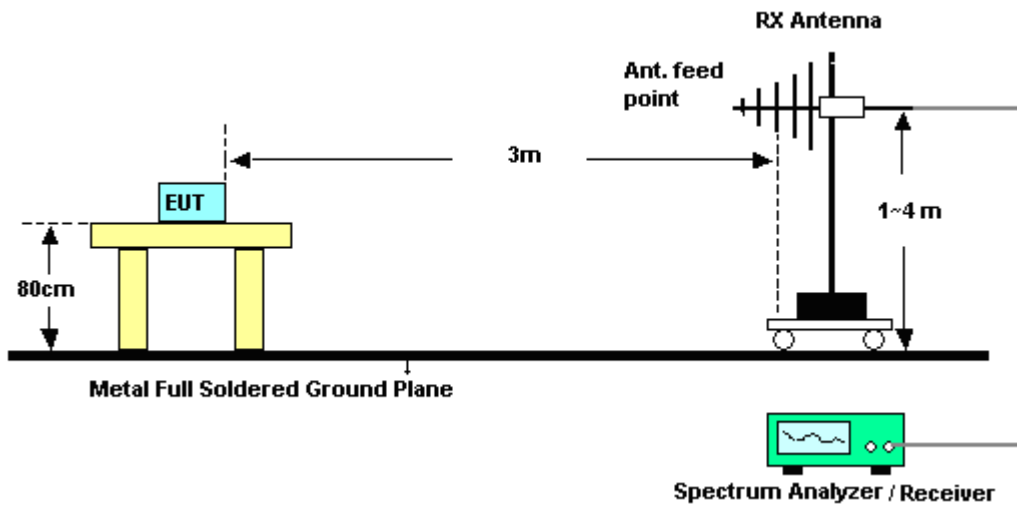

For radiated emissions above 1GHz

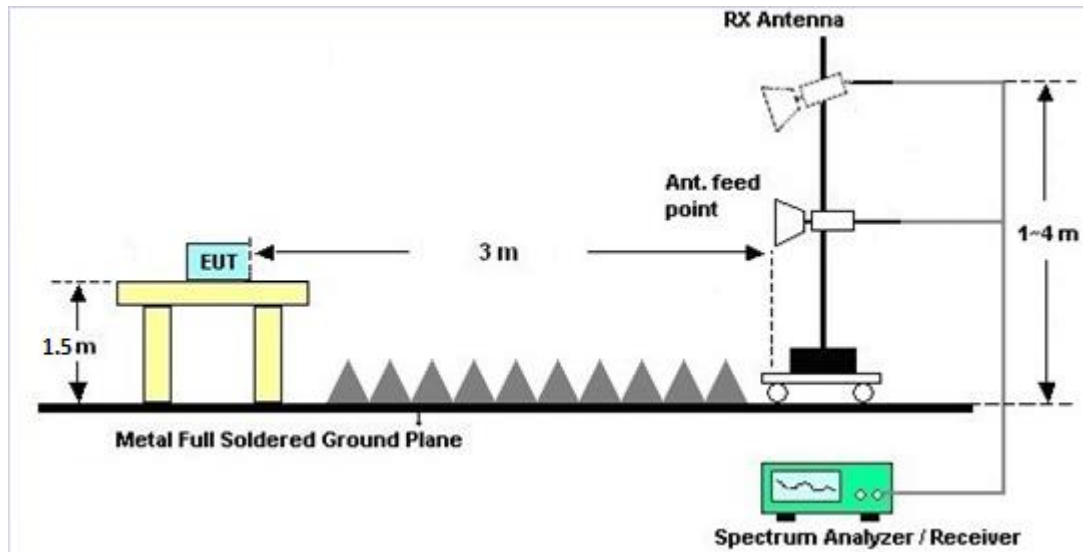

3.5.5 Test Results of Radiated Spurious Emissions (9kHz ~ 30MHz)

The low frequency, which started from 9 kHz to 30MHz, was pre-scanned and the result which was 20dB lower than the limit line per 15.31(o) was not reported.

3.5.6 Test Result of Radiated Spurious at Band Edges

Please refer to Appendix B and C.

3.5.7 Duty Cycle

Please refer to Appendix D.

3.5.8 Test Result of Radiated Spurious Emission (30MHz ~ 10th Harmonic)

Please refer to Appendix B and C.



3.6 AC Conducted Emission Measurement

3.6.1 Limit of AC Conducted Emission

For equipment that is designed to be connected to the public utility (AC) power line, the radio frequency voltage that is conducted back onto the AC power line on any frequency or frequencies within the band 150 kHz to 30 MHz shall not exceed the limits in the following table.

Frequency of Emission (MHz)	Conducted Limit (dB μ V)	
	Quasi-Peak	Average
0.15-0.5	66 to 56*	56 to 46*
0.5-5	56	46
5-30	60	50

*Decreases with the logarithm of the frequency.

3.6.2 Measuring Instruments

The measuring equipment is listed in the section 4 of this test report.

3.6.3 Test Procedures

1. The EUT was placed 0.4 meter from the conducting wall of the shielding room, and it was kept at least 80 centimeters from any other grounded conducting surface.
2. Connect EUT to the power mains through a line impedance stabilization network (LISN).
3. All the support units are connecting to the other LISN.
4. The LISN provides 50 ohm coupling impedance for the measuring instrument.
5. The FCC states that a 50 ohm, 50 microhenry LISN should be used.
6. Both sides of AC line were checked for maximum conducted interference.
7. The frequency range from 150 kHz to 30 MHz was searched.
8. Set the test-receiver system to Peak Detect Function and specified bandwidth (IF bandwidth = 9kHz) with Maximum Hold Mode.



3.6.5 Test Result of AC Conducted Emission

Test Mode :	Mode 1	Temperature :	22~23°C
Test Engineer :	Kai-Chun Chu	Relative Humidity :	51~52%
Test Voltage :	120Vac / 60Hz	Phase :	Line
Function Type :	WLAN (2.4GHz) Link + Bluetooth Link + MPEG4 + Earphone + MicroSD Card + USB Cable (Charging from Adapter)		

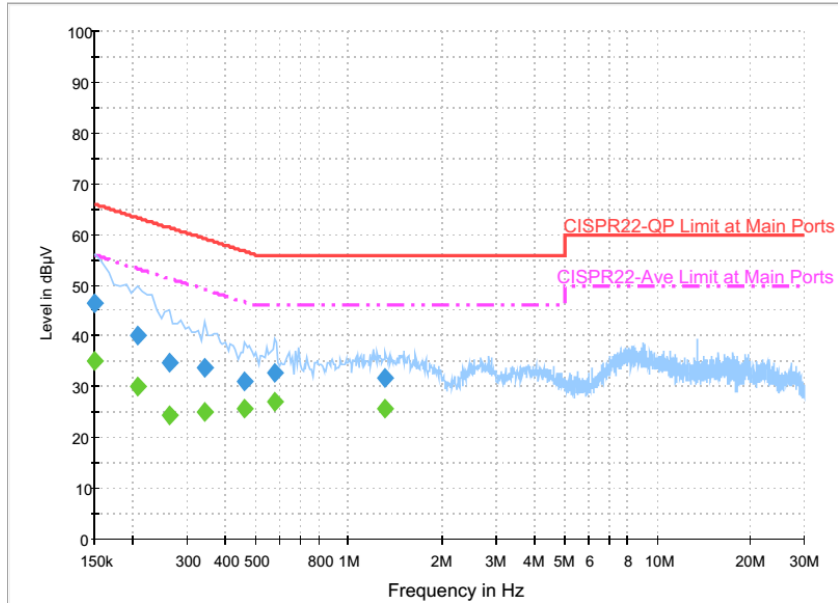

Final Result : Quasi-Peak

Frequency (MHz)	Quasi-Peak (dBµV)	Filter	Line	Corr. (dB)	Margin (dB)	Limit (dBµV)
0.150000	46.4	Off	L1	19.6	19.6	66.0
0.206000	40.2	Off	L1	19.6	23.2	63.4
0.262000	34.9	Off	L1	19.6	26.5	61.4
0.342000	33.8	Off	L1	19.6	25.4	59.2
0.462000	31.2	Off	L1	19.6	25.5	56.7
0.574000	32.8	Off	L1	19.6	23.2	56.0
1.310000	31.8	Off	L1	19.6	24.2	56.0

Final Result : Average

Frequency (MHz)	Average (dBµV)	Filter	Line	Corr. (dB)	Margin (dB)	Limit (dBµV)
0.150000	35.2	Off	L1	19.6	20.8	56.0
0.206000	29.9	Off	L1	19.6	23.5	53.4
0.262000	24.3	Off	L1	19.6	27.1	51.4
0.342000	25.2	Off	L1	19.6	24.0	49.2
0.462000	25.9	Off	L1	19.6	20.8	46.7
0.574000	27.2	Off	L1	19.6	18.8	46.0
1.310000	25.8	Off	L1	19.6	20.2	46.0



Test Mode :	Mode 1	Temperature :	22~23°C
Test Engineer :	Kai-Chun Chu	Relative Humidity :	51~52%%
Test Voltage :	120Vac / 60Hz	Phase :	Neutral
Function Type :	WLAN (2.4GHz) Link + Bluetooth Link + MPEG4 + Earphone + MicroSD Card + USB Cable (Charging from Adapter)		

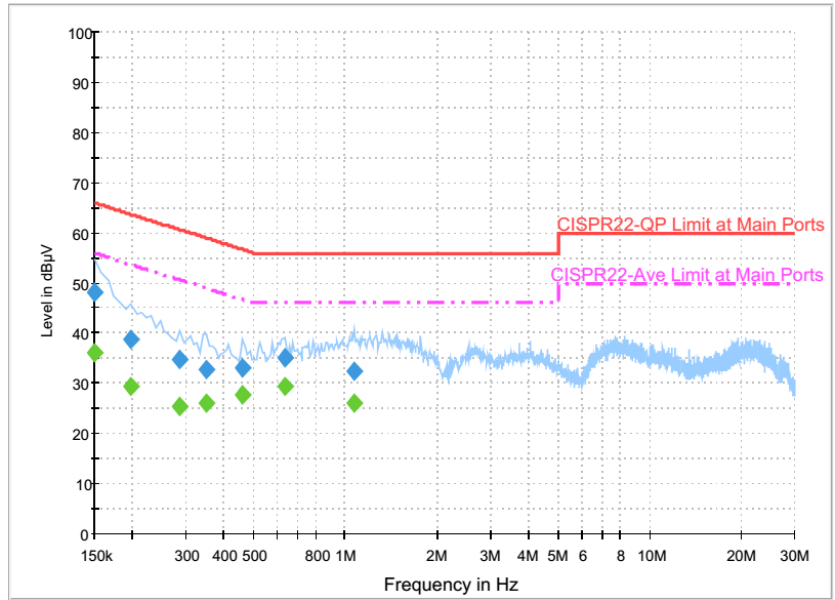

Final Result : Quasi-Peak

Frequency (MHz)	Quasi-Peak (dBµV)	Filter	Line	Corr. (dB)	Margin (dB)	Limit (dBµV)
0.150000	48.0	Off	N	19.6	18.0	66.0
0.198000	38.9	Off	N	19.6	24.8	63.7
0.286000	34.7	Off	N	19.6	25.9	60.6
0.350000	32.7	Off	N	19.6	26.3	59.0
0.462000	33.1	Off	N	19.6	23.6	56.7
0.630000	35.1	Off	N	19.6	20.9	56.0
1.070000	32.5	Off	N	19.6	23.5	56.0

Final Result : Average

Frequency (MHz)	Average (dBµV)	Filter	Line	Corr. (dB)	Margin (dB)	Limit (dBµV)
0.150000	36.2	Off	N	19.6	19.8	56.0
0.198000	29.5	Off	N	19.6	24.2	53.7
0.286000	25.4	Off	N	19.6	25.2	50.6
0.350000	26.1	Off	N	19.6	22.9	49.0
0.462000	27.7	Off	N	19.6	19.0	46.7
0.630000	29.4	Off	N	19.6	16.6	46.0
1.070000	26.2	Off	N	19.6	19.8	46.0



3.7 Antenna Requirements

3.7.1 Standard Applicable

If directional gain of transmitting antennas is greater than 6dBi, the power shall be reduced by the same level in dB comparing to gain minus 6dBi. For the fixed point-to-point operation, the power shall be reduced by one dB for every 3 dB that the directional gain of the antenna exceeds 6 dBi. The use of a permanently attached antenna or of an antenna that uses a unique coupling to the intentional radiator shall be considered sufficient to comply with the FCC rule.

3.7.2 Antenna Anti-Replacement Construction

An embedded-in antenna design is used.

3.7.3 Antenna Gain

The antenna peak gain of EUT is less than 6 dBi. Therefore, it is not necessary to reduce maximum peak output power limit.



4 List of Measuring Equipment

Instrument	Manufacturer	Model No.	Serial No.	Characteristics	Calibration Date	Test Date	Due Date	Remark
Power Meter	Anritsu	ML2495A	1218006	300MHz~40GHz z	Oct. 06, 2016	Jan. 25, 2017 ~ Feb. 03, 2017	Oct. 05, 2017	Conducted (TH05-HY)
Power Sensor	Anritsu	MA2411B	1207363	300MHz~40GHz z	Oct. 06, 2016	Jan. 25, 2017 ~ Feb. 03, 2017	Oct. 05, 2017	Conducted (TH05-HY)
Spectrum Analyzer	Rohde & Schwarz	FSP40	100057	9kHz-40GHz	Nov. 25, 2016	Jan. 25, 2017 ~ Feb. 03, 2017	Nov. 24, 2017	Conducted (TH05-HY)
Programmable Power Supply	GW Instek	PSS-2005	EL890094	1V~20V 0.5A~5A	Oct. 11, 2016	Jan. 25, 2017 ~ Feb. 03, 2017	Oct. 10, 2017	Conducted (TH05-HY)
AC Power Source	ChainTek	APC-1000W	N/A	N/A	N/A	Jan. 30, 2017	N/A	Conduction (CO05-HY)
EMI Test Receiver	Rohde & Schwarz	ESCI 7	100724	9kHz~7GHz	Aug. 30, 2016	Jan. 30, 2017	Aug. 29, 2017	Conduction (CO05-HY)
LISN	Rohde & Schwarz	ENV216	100080	9kHz~30MHz	Nov. 29, 2016	Jan. 30, 2017	Nov. 28, 2017	Conduction (CO05-HY)
Bilog Antenna	TESEQ	CBL 6111D&00800 N1D01N-06	35419&03	30MHz to 1GHz	Jan. 07, 2017	Jan. 26, 2017 ~ Feb. 03, 2017	Jan. 06, 2018	Radiation (03CH07-HY)
Double Ridge Horn Antenna	ESCO	3117	00075962	1GHz ~ 18GHz	Aug. 19, 2016	Jan. 26, 2017 ~ Feb. 03, 2017	Aug. 18, 2017	Radiation (03CH07-HY)
EMI Test Receiver	Keysight	N9038A (MXE)	MY541300 85	20Hz ~ 8.4GHz	Oct. 26, 2016	Jan. 26, 2017 ~ Feb. 03, 2017	Oct. 25, 2017	Radiation (03CH07-HY)
Loop Antenna	Rohde & Schwarz	HFH2-Z2	100315	9 kHz~30 MHz	Sep. 02, 2015	Jan. 26, 2017 ~ Feb. 03, 2017	Sep. 01, 2017	Radiation (03CH07-HY)
Preamplifier	MITEQ	AMF-7D-0010 1800-30-10P	1590075	1GHz ~ 18GHz	Apr. 15, 2016	Jan. 26, 2017 ~ Feb. 03, 2017	Apr. 14, 2017	Radiation (03CH07-HY)
Preamplifier	COM-POWER	PA-103A	161241	10MHz-1GHz	Mar. 18, 2016	Jan. 26, 2017 ~ Feb. 03, 2017	Mar. 17, 2017	Radiation (03CH07-HY)
Preamplifier	Agilent	8449B	3008A023 62	1GHz~ 26.5GHz	Oct. 12, 2016	Jan. 26, 2017 ~ Feb. 03, 2017	Oct. 11, 2017	Radiation (03CH07-HY)
Spectrum Analyzer	Agilent	N9010A	MY534701 18	10Hz~44GHz	Feb. 27, 2016	Jan. 26, 2017 ~ Feb. 03, 2017	Feb. 26, 2017	Radiation (03CH07-HY)
Antenna Mast	Max-Full	MFA520BS	N/A	1m~4m	N/A	Jan. 26, 2017 ~ Feb. 03, 2017	N/A	Radiation (03CH07-HY)
Turn Table	ChainTek	Chaintek 3000	N/A	0~360 Degree	N/A	Jan. 26, 2017 ~ Feb. 03, 2017	N/A	Radiation (03CH07-HY)
Loop Cable	Rohde & Schwarz	N/A	N/A	9KHz~30MHz	Dec. 01, 2016	Jan. 26, 2017 ~ Feb. 03, 2017	Nov. 30, 2017	Radiation (03CH07-HY)
Preamplifier	MITEQ	JS44-180040 00-33-8P	1840917	18GHz ~ 40GHz	Jun. 14, 2016	Jan. 26, 2017 ~ Feb. 03, 2017	Jun. 13, 2017	Radiation (03CH07-HY)
SHF-EHF Horn Antenna	SCHWARZBE CK	BBHA 9170	BBHA9170 584	18GHz- 40GHz	Nov. 08, 2016	Jan. 26, 2017 ~ Feb. 03, 2017	Nov. 07, 2017	Radiation (03CH07-HY)



5 Uncertainty of Evaluation

Uncertainty of Conducted Emission Measurement (150 kHz ~ 30 MHz)

Measuring Uncertainty for a Level of Confidence of 95% ($U = 2Uc(y)$)	2.7
---	-----

Uncertainty of Radiated Emission Measurement (30 MHz ~ 1000 MHz)

Measuring Uncertainty for a Level of Confidence of 95% ($U = 2Uc(y)$)	5.7
---	-----

Uncertainty of Radiated Emission Measurement (1000 MHz ~ 18000 MHz)

Measuring Uncertainty for a Level of Confidence of 95% ($U = 2Uc(y)$)	5.5
---	-----

Uncertainty of Radiated Emission Measurement (18000 MHz ~ 40000 MHz)

Measuring Uncertainty for a Level of Confidence of 95% ($U = 2Uc(y)$)	5.2
---	-----



Appendix A. Conducted Test Results

A1 - DTS Part

Test Engineer:	Tommy Lee	Temperature:	21~25	°C
Test Date:	2017/1/25~2017/2/3	Relative Humidity:	51~54	%

TEST RESULTS DATA
6dB and 99% Occupied Bandwidth

2.4GHz Band								
Mod.	Data Rate	N _{TX}	CH.	Freq. (MHz)	99% Occupied BW (MHz)	6dB BW (MHz)	6dB BW Limit (MHz)	Pass/Fail
11b	1Mbps	1	1	2412	13.80	9.04	0.50	Pass
11b	1Mbps	1	6	2437	13.80	9.00	0.50	Pass
11b	1Mbps	1	11	2462	13.75	9.00	0.50	Pass
11b	1Mbps	1	12	2467	13.80	9.00	0.50	Pass
11b	1Mbps	1	13	2472	13.75	9.00	0.50	Pass
11g	6Mbps	1	1	2412	17.45	15.68	0.50	Pass
11g	6Mbps	1	6	2437	17.65	15.48	0.50	Pass
11g	6Mbps	1	11	2462	18.35	15.48	0.50	Pass
11g	6Mbps	1	12	2467	17.70	15.68	0.50	Pass
11g	6Mbps	1	13	2472	17.45	15.68	0.50	Pass
HT20	MCS0	1	1	2412	18.20	16.88	0.50	Pass
HT20	MCS0	1	6	2437	18.30	15.96	0.50	Pass
HT20	MCS0	1	11	2462	18.35	16.76	0.50	Pass
HT20	MCS0	1	12	2467	18.15	16.76	0.50	Pass
HT20	MCS0	1	13	2472	18.20	16.80	0.50	Pass

TEST RESULTS DATA
Peak Power Table

2.4GHz Band										
Mod.	Data Rate	N _{TX}	CH.	Freq. (MHz)	Peak Conducted Power (dBm)	Conducted Power Limit (dBm)	DG (dBi)	EIRP Power (dBm)	EIRP Power Limit (dBm)	Pass /Fail
11b	1Mbps	1	1	2412	16.04	30.00	2.10	18.14	36.00	Pass
11b	1Mbps	1	6	2437	16.08	30.00	2.10	18.18	36.00	Pass
11b	1Mbps	1	11	2462	15.97	30.00	2.10	18.07	36.00	Pass
11b	1Mbps	1	12	2467	15.93	30.00	2.10	18.03	36.00	Pass
11b	1Mbps	1	13	2472	14.83	30.00	2.10	16.93	36.00	Pass
11g	6Mbps	1	1	2412	21.70	30.00	2.10	23.80	36.00	Pass
11g	6Mbps	1	6	2437	21.31	30.00	2.10	23.41	36.00	Pass
11g	6Mbps	1	11	2462	21.34	30.00	2.10	23.44	36.00	Pass
11g	6Mbps	1	12	2467	20.38	30.00	2.10	22.48	36.00	Pass
11g	6Mbps	1	13	2472	19.32	30.00	2.10	21.42	36.00	Pass
HT20	MCS0	1	1	2412	22.09	30.00	2.10	24.19	36.00	Pass
HT20	MCS0	1	6	2437	22.02	30.00	2.10	24.12	36.00	Pass
HT20	MCS0	1	11	2462	21.95	30.00	2.10	24.05	36.00	Pass
HT20	MCS0	1	12	2467	21.06	30.00	2.10	23.16	36.00	Pass
HT20	MCS0	1	13	2472	19.62	30.00	2.10	21.72	36.00	Pass

TEST RESULTS DATA
Average Power Table
(Reporting Only)

2.4GHz Band						
Mod.	Data Rate	N _{TX}	CH.	Freq. (MHz)	Duty Factor (dB)	Average Conducted Power (dBm)
11b	1Mbps	1	1	2412	12.58	13.71
11b	1Mbps	1	6	2437	12.58	13.77
11b	1Mbps	1	11	2462	12.58	13.67
11b	1Mbps	1	12	2467	12.58	13.63
11b	1Mbps	1	13	2472	12.58	12.58
11g	6Mbps	1	1	2412	0.33	13.55
11g	6Mbps	1	6	2437	0.33	13.45
11g	6Mbps	1	11	2462	0.33	13.58
11g	6Mbps	1	12	2467	0.33	11.56
11g	6Mbps	1	13	2472	0.33	9.68
HT20	MCS0	1	1	2412	8.60	12.51
HT20	MCS0	1	6	2437	8.60	13.46
HT20	MCS0	1	11	2462	8.60	13.49
HT20	MCS0	1	12	2467	8.60	10.63
HT20	MCS0	1	13	2472	8.60	8.60

TEST RESULTS DATA
Peak Power Density

2.4GHz Band								
Mod.	Data Rate	N _{TX}	CH.	Freq. (MHz)	Peak PSD (dBm /3kHz)	DG (dBi)	Peak PSD Limit (dBm /3kHz)	Pass/Fail
11b	1Mbps	1	1	2412	-11.01	2.10	8.00	Pass
11b	1Mbps	1	6	2437	-12.13	2.10	8.00	Pass
11b	1Mbps	1	11	2462	-10.94	2.10	8.00	Pass
11b	1Mbps	1	12	2467	-12.33	2.10	8.00	Pass
11b	1Mbps	1	13	2472	-12.09	2.10	8.00	Pass
11g	6Mbps	1	1	2412	-13.08	2.10	8.00	Pass
11g	6Mbps	1	6	2437	-14.16	2.10	8.00	Pass
11g	6Mbps	1	11	2462	-13.64	2.10	8.00	Pass
11g	6Mbps	1	12	2467	-16.20	2.10	8.00	Pass
11g	6Mbps	1	13	2472	-16.92	2.10	8.00	Pass
HT20	MCS0	1	1	2412	-14.68	2.10	8.00	Pass
HT20	MCS0	1	6	2437	-13.76	2.10	8.00	Pass
HT20	MCS0	1	11	2462	-14.23	2.10	8.00	Pass
HT20	MCS0	1	12	2467	-16.47	2.10	8.00	Pass
HT20	MCS0	1	13	2472	-18.62	2.10	8.00	Pass



Appendix B. Radiated Spurious Emission

Test Engineer :	Jesse Wang, James Chiu, and Daniel Lee	Temperature :	21~22°C
		Relative Humidity :	44~48%

2.4GHz 2400~2483.5MHz

WIFI 802.11b (Band Edge @ 3m)

WIFI	Note	Frequency	Level	Over	Limit	Read	Antenna	Cable	Preamp	Ant	Table	Peak	Pol.
Ant.				Limit	Line	Level	Factor	Loss	Factor	Pos	Pos	Avg.	
1		(MHz)	(dBμV/m)	(dB)	(dBμV/m)	(dBμV)	(dB/m)	(dB)	(dB)	(cm)	(deg)	(P/A)	(H/V)
802.11b CH 01 2412MHz		2380.875	55.62	-18.38	74	51.14	32.14	7.31	34.97	140	240	P	H
		2370.9	44.68	-9.32	54	40.27	32.14	7.24	34.97	140	240	A	H
	*	2412	107.89	-	-	103.32	32.24	7.31	34.98	140	240	P	H
	*	2412	104.71	-	-	100.14	32.24	7.31	34.98	140	240	A	H
		2376.36	56.51	-17.49	74	52.1	32.14	7.24	34.97	375	269	P	V
		2386.02	44.62	-9.38	54	40.09	32.19	7.31	34.97	375	269	A	V
	*	2412	108.34	-	-	103.77	32.24	7.31	34.98	375	269	P	V
	*	2412	105.31	-	-	100.74	32.24	7.31	34.98	375	269	A	V
802.11b CH 06 2437MHz		2316.44	54.94	-19.06	74	50.79	31.93	7.18	34.96	122	242	P	H
		2387.7	44.16	-9.84	54	39.63	32.19	7.31	34.97	122	242	A	H
	*	2437	106.55	-	-	101.84	32.34	7.36	34.99	122	242	P	H
	*	2437	103.49	-	-	98.78	32.34	7.36	34.99	122	242	A	H
		2498.6	55.62	-18.38	74	50.73	32.5	7.4	35.01	122	242	P	H
		2488.66	44.4	-9.6	54	39.5	32.5	7.4	35	122	242	A	H
		2325.12	54.83	-19.17	74	50.63	31.98	7.18	34.96	327	272	P	V
		2387.98	44.34	-9.66	54	39.81	32.19	7.31	34.97	327	272	A	V
	*	2437	107.31	-	-	102.6	32.34	7.36	34.99	327	272	P	V
	*	2437	104.53	-	-	99.82	32.34	7.36	34.99	327	272	A	V
		2493.56	54.66	-19.34	74	49.77	32.5	7.4	35.01	327	272	P	V
		2488.87	44.32	-9.68	54	39.42	32.5	7.4	35	327	272	A	V



802.11b CH 11 2462MHz	*	2462	105.73	-	-	100.92	32.4	7.4	34.99	147	243	P	H
	*	2462	102.32	-	-	97.51	32.4	7.4	34.99	147	243	A	H
		2495.88	55.58	-18.42	74	50.69	32.5	7.4	35.01	147	243	P	H
		2487.88	44.47	-9.53	54	39.57	32.5	7.4	35	147	243	A	H
	*	2462	106.07	-	-	101.26	32.4	7.4	34.99	357	270	P	V
	*	2462	102.65	-	-	97.84	32.4	7.4	34.99	357	270	A	V
		2490	54.92	-19.08	74	50.02	32.5	7.4	35	357	270	P	V
		2485.36	44.44	-9.56	54	39.59	32.45	7.4	35	357	270	A	V
802.11b CH 12 2467MHz	*	2467	105.76	-	-	100.96	32.4	7.4	35	134	241	P	H
	*	2467	102.62	-	-	97.82	32.4	7.4	35	134	241	A	H
		2483.76	56.45	-17.55	74	51.6	32.45	7.4	35	134	241	P	H
		2483.92	48.88	-5.12	54	44.03	32.45	7.4	35	134	241	A	H
	*	2467	105.49	-	-	100.69	32.4	7.4	35	359	265	P	V
	*	2467	102.33	-	-	97.53	32.4	7.4	35	359	265	A	V
		2483.8	58.4	-15.6	74	53.55	32.45	7.4	35	359	265	P	V
		2483.96	48.81	-5.19	54	43.96	32.45	7.4	35	359	265	A	V
802.11b CH 13 2472MHz	*	2472	104.42	-	-	99.57	32.45	7.4	35	105	242	P	H
	*	2472	101.35	-	-	96.5	32.45	7.4	35	105	242	A	H
		2487.4	58.18	-15.82	74	53.33	32.45	7.4	35	105	242	P	H
		2487.28	51.68	-2.32	54	46.83	32.45	7.4	35	105	242	A	H
	*	2472	104.56	-	-	99.71	32.45	7.4	35	354	271	P	V
	*	2472	101.38	-	-	96.53	32.45	7.4	35	354	271	A	V
		2487.76	58.3	-15.7	74	53.4	32.5	7.4	35	354	271	P	V
		2487.36	51.21	-2.79	54	46.36	32.45	7.4	35	354	271	A	V
Remark	1. No other spurious found. 2. All results are PASS against Peak and Average limit line.												



2.4GHz 2400~2483.5MHz

WIFI 802.11b (Harmonic @ 3m)

WIFI Ant. 1	Note	Frequency (MHz)	Level (dBμV/m)	Over Limit (dB)	Limit Line (dBμV/m)	Read Level (dBμV)	Antenna Factor (dB/m)	Cable Loss (dB)	Preamp Factor (dB)	Ant Pos (cm)	Table Pos (deg)	Peak Avg. (P/A)	Pol. (H/V)
802.11b CH 01 2412MHz		4824	45.08	-28.92	74	58.8	33.64	11.68	59.04	100	0	P	H
		4824	44.65	-29.35	74	58.37	33.64	11.68	59.04	100	0	P	V
802.11b CH 06 2437MHz		4872	47.72	-26.28	74	61.59	33.54	11.53	58.94	100	0	P	H
		7311	38.74	-35.26	74	48.17	34.69	13.81	57.93	100	0	P	H
		4872	44.6	-29.4	74	58.47	33.54	11.53	58.94	100	0	P	V
802.11b CH 11 2462MHz		7311	38.8	-35.2	74	48.23	34.69	13.81	57.93	100	0	P	V
		4926	47.95	-26.05	74	61.98	33.44	11.37	58.84	100	0	P	H
		7386	39.08	-34.92	74	48.72	34.47	13.95	58.06	100	0	P	H
		4926	43.94	-30.06	74	57.97	33.44	11.37	58.84	100	0	P	V
802.11b CH 12 2467MHz		7386	38.51	-35.49	74	48.15	34.47	13.95	58.06	100	0	P	V
		4932	47.62	-26.38	74	61.65	33.44	11.37	58.84	100	0	P	H
		7404	38.56	-35.44	74	48.27	34.42	13.95	58.08	100	0	P	H
		4932	43.96	-30.04	74	57.99	33.44	11.37	58.84	100	0	P	V
802.11b CH 13 2472MHz		7404	39.02	-34.98	74	48.73	34.42	13.95	58.08	100	0	P	V
		4944	45.43	-28.57	74	59.61	33.4	11.22	58.8	100	0	P	H
		7416	39.55	-34.45	74	49.26	34.42	13.95	58.08	100	0	P	H
		4944	43.25	-30.75	74	57.43	33.4	11.22	58.8	100	0	P	V
Remark		7416	39.12	-34.88	74	48.83	34.42	13.95	58.08	100	0	P	V
	1. No other spurious found. 2. All results are PASS against Peak and Average limit line.												



2.4GHz 2400~2483.5MHz

WIFI 802.11g (Band Edge @ 3m)

WIFI Ant. 1	Note	Frequency (MHz)	Level (dBμV/m)	Over Limit (dB)	Limit Line (dBμV/m)	Read Level (dBμV)	Antenna Factor (dB/m)	Cable Loss (dB)	Preamp Factor (dB)	Ant Pos (cm)	Table Pos (deg)	Peak Avg. (P/A)	Pol. (H/V)
802.11g CH 01 2412MHz		2389.485	61.39	-12.61	74	56.86	32.19	7.31	34.97	124	244	P	H
		2390	49.24	-4.76	54	44.72	32.19	7.31	34.98	124	244	A	H
	*	2412	106.44	-	-	101.87	32.24	7.31	34.98	124	244	P	H
	*	2412	98.81	-	-	94.24	32.24	7.31	34.98	124	244	A	H
		2389.59	61.76	-12.24	74	57.23	32.19	7.31	34.97	331	271	P	V
		2390	50.66	-3.34	54	46.14	32.19	7.31	34.98	331	271	A	V
	*	2412	108.26	-	-	103.69	32.24	7.31	34.98	331	271	P	V
	*	2412	100.56	-	-	95.99	32.24	7.31	34.98	331	271	A	V
802.11g CH 06 2437MHz		2360.82	54.98	-19.02	74	50.62	32.09	7.24	34.97	125	244	P	H
		2368.66	45.59	-8.41	54	41.18	32.14	7.24	34.97	125	244	A	H
	*	2437	108.56	-	-	103.85	32.34	7.36	34.99	125	244	P	H
	*	2437	100.73	-	-	96.02	32.34	7.36	34.99	125	244	A	H
		2495.17	54.96	-19.04	74	50.07	32.5	7.4	35.01	125	244	P	H
		2486.77	45.57	-8.43	54	40.72	32.45	7.4	35	125	244	A	H
		2378.18	56.71	-17.29	74	52.3	32.14	7.24	34.97	360	272	P	V
		2373.98	45.59	-8.41	54	41.18	32.14	7.24	34.97	360	272	A	V
	*	2437	108.73	-	-	104.02	32.34	7.36	34.99	360	272	P	V
	*	2437	101.06	-	-	96.35	32.34	7.36	34.99	360	272	A	V
		2493.49	55.14	-18.86	74	50.25	32.5	7.4	35.01	360	272	P	V
		2485.93	45.5	-8.5	54	40.65	32.45	7.4	35	360	272	A	V



802.11g CH 11 2462MHz	*	2462	107.24	-	-	102.43	32.4	7.4	34.99	131	241	P	H
	*	2462	99.61	-	-	94.8	32.4	7.4	34.99	131	241	A	H
		2484.4	62.14	-11.86	74	57.29	32.45	7.4	35	131	241	P	H
		2483.64	49.8	-4.2	54	44.95	32.45	7.4	35	131	241	A	H
	*	2462	106.96	-	-	102.15	32.4	7.4	34.99	361	272	P	V
	*	2462	99.63	-	-	94.82	32.4	7.4	34.99	361	272	A	V
		2483.8	61.5	-12.5	74	56.65	32.45	7.4	35	361	272	P	V
		2483.56	49.07	-4.93	54	44.22	32.45	7.4	35	361	272	A	V
802.11g CH 12 2467MHz	*	2467	105.11	-	-	100.31	32.4	7.4	35	135	243	P	H
	*	2467	97.63	-	-	92.83	32.4	7.4	35	135	243	A	H
		2483.6	64.27	-9.73	74	59.42	32.45	7.4	35	135	243	P	H
		2483.52	52.62	-1.38	54	47.77	32.45	7.4	35	135	243	A	H
	*	2467	105.39	-	-	100.59	32.4	7.4	35	359	270	P	V
	*	2467	97.59	-	-	92.79	32.4	7.4	35	359	270	A	V
		2483.76	64.7	-9.3	74	59.85	32.45	7.4	35	359	270	P	V
		2483.52	52.33	-1.67	54	47.48	32.45	7.4	35	359	270	A	V
802.11g CH 13 2472MHz	*	2472	103.29	-	-	98.44	32.45	7.4	35	104	240	P	H
	*	2472	95.74	-	-	90.89	32.45	7.4	35	104	240	A	H
		2484.64	64.22	-9.78	74	59.37	32.45	7.4	35	104	240	P	H
		2484.04	52.12	-1.88	54	47.27	32.45	7.4	35	104	240	A	H
	*	2472	103.47	-	-	98.62	32.45	7.4	35	358	270	P	V
	*	2472	95.79	-	-	90.94	32.45	7.4	35	358	270	A	V
		2483.56	63.91	-10.09	74	59.06	32.45	7.4	35	358	270	P	V
		2484.16	51.75	-2.25	54	46.9	32.45	7.4	35	358	270	A	V
Remark	1. No other spurious found. 2. All results are PASS against Peak and Average limit line.												



2.4GHz 2400~2483.5MHz

WIFI 802.11g (Harmonic @ 3m)

WIFI Ant. 1	Note	Frequency (MHz)	Level (dBμV/m)	Over Limit (dB)	Limit Line (dBμV/m)	Read Level (dBμV)	Antenna Factor (dB/m)	Cable Loss (dB)	Preamp Factor (dB)	Ant Pos (cm)	Table Pos (deg)	Peak Avg. (P/A)	Pol. (H/V)
802.11g CH 01 2412MHz		4824	45.4	-28.6	74	59.12	33.64	11.68	59.04	100	0	P	H
		4824	44.29	-29.71	74	58.01	33.64	11.68	59.04	100	0	P	V
802.11g CH 06 2437MHz		4872	47.46	-26.54	74	61.33	33.54	11.53	58.94	100	0	P	H
		7311	39.09	-34.91	74	48.52	34.69	13.81	57.93	100	0	P	H
		4878	42.6	-31.4	74	56.47	33.54	11.53	58.94	100	0	P	V
802.11g CH 11 2462MHz		7308	39.43	-34.57	74	48.86	34.69	13.81	57.93	100	0	P	V
		4926	47.11	-26.89	74	61.14	33.44	11.37	58.84	100	0	P	H
		7386	38.76	-35.24	74	48.4	34.47	13.95	58.06	100	0	P	H
		4926	43.46	-30.54	74	57.49	33.44	11.37	58.84	100	0	P	V
802.11g CH 12 2467MHz		7386	39.39	-34.61	74	49.03	34.47	13.95	58.06	100	0	P	V
		4932	44.55	-29.45	74	58.58	33.44	11.37	58.84	100	0	P	H
		7404	38.61	-35.39	74	48.32	34.42	13.95	58.08	100	0	P	H
		4932	40.65	-33.35	74	54.68	33.44	11.37	58.84	100	0	P	V
802.11g CH 13 2472MHz		7404	39	-35	74	48.71	34.42	13.95	58.08	100	0	P	V
		4944	41.82	-32.18	74	56	33.4	11.22	58.8	100	0	P	H
		7416	38.61	-35.39	74	48.32	34.42	13.95	58.08	100	0	P	H
		4944	40.08	-33.92	74	54.26	33.4	11.22	58.8	100	0	P	V
Remark		7416	39.24	-34.76	74	48.95	34.42	13.95	58.08	100	0	P	V
	1. No other spurious found. 2. All results are PASS against Peak and Average limit line.												



2.4GHz 2400~2483.5MHz

WIFI 802.11n HT20 (Band Edge @ 3m)

WIFI Ant. 1	Note	Frequency (MHz)	Level (dBμV/m)	Over Limit (dB)	Limit Line (dBμV/m)	Read Level (dBμV)	Antenna Factor (dB/m)	Cable Loss (dB)	Preamp Factor (dB)	Ant Pos (cm)	Table Pos (deg)	Peak Avg. (P/A)	Pol. (H/V)
802.11n HT20 CH 01 2412MHz		2390	68.8	-5.2	74	64.28	32.19	7.31	34.98	140	240	P	H
		2390	51.99	-2.01	54	47.47	32.19	7.31	34.98	140	240	A	H
	*	2412	107.23	-	-	102.66	32.24	7.31	34.98	140	240	P	H
	*	2412	99.65	-	-	95.08	32.24	7.31	34.98	140	240	A	H
		2390	68.28	-5.72	74	63.76	32.19	7.31	34.98	331	268	P	V
		2390	52.35	-1.65	54	47.83	32.19	7.31	34.98	331	268	A	V
	*	2412	108.2	-	-	103.63	32.24	7.31	34.98	331	268	P	V
	*	2412	100.66	-	-	96.09	32.24	7.31	34.98	331	268	A	V
802.11n HT20 CH 06 2437MHz		2387.42	56.32	-17.68	74	51.79	32.19	7.31	34.97	140	241	P	H
		2388.54	46.07	-7.93	54	41.54	32.19	7.31	34.97	140	241	A	H
	*	2437	109.5	-	-	104.79	32.34	7.36	34.99	140	241	P	H
	*	2437	101.76	-	-	97.05	32.34	7.36	34.99	140	241	A	H
		2497.62	55.13	-18.87	74	50.24	32.5	7.4	35.01	140	241	P	H
		2487.05	45.56	-8.44	54	40.71	32.45	7.4	35	140	241	A	H
		2382.8	56.1	-17.9	74	51.62	32.14	7.31	34.97	326	266	P	V
		2387.56	46.17	-7.83	54	41.64	32.19	7.31	34.97	326	266	A	V
	*	2437	109.76	-	-	105.05	32.34	7.36	34.99	326	266	P	V
	*	2437	102.08	-	-	97.37	32.34	7.36	34.99	326	266	A	V
		2483.5	54.91	-19.09	74	50.06	32.45	7.4	35	326	266	P	V
	2499.93	45.46	-8.54	54	40.57	32.5	7.4	35.01	326	266	A	V	



802.11n HT20 CH 11 2462MHz	*	2462	107.77	-	-	102.96	32.4	7.4	34.99	138	240	P	H
	*	2462	100.3	-	-	95.49	32.4	7.4	34.99	138	240	A	H
		2485.08	65.55	-8.45	74	60.7	32.45	7.4	35	138	240	P	H
		2483.6	52.27	-1.73	54	47.42	32.45	7.4	35	138	240	A	H
	*	2462	107.09	-	-	102.28	32.4	7.4	34.99	364	286	P	V
	*	2462	99.65	-	-	94.84	32.4	7.4	34.99	364	286	A	V
		2483.6	62.63	-11.37	74	57.78	32.45	7.4	35	364	286	P	V
		2483.6	50.54	-3.46	54	45.69	32.45	7.4	35	364	286	A	V
802.11n HT20 CH 12 2467MHz	*	2467	104.69	-	-	99.89	32.4	7.4	35	152	238	P	H
	*	2467	96.89	-	-	92.09	32.4	7.4	35	152	238	A	H
		2484.24	65.01	-8.99	74	60.16	32.45	7.4	35	152	238	P	H
		2484.2	49.78	-4.22	54	44.93	32.45	7.4	35	152	238	A	H
	*	2467	104.79	-	-	99.99	32.4	7.4	35	318	265	P	V
	*	2467	97.17	-	-	92.37	32.4	7.4	35	318	265	A	V
		2483.88	67.38	-6.62	74	62.53	32.45	7.4	35	318	265	P	V
		2483.52	50.81	-3.19	54	45.96	32.45	7.4	35	318	265	A	V
802.11n HT20 CH 13 2472MHz	*	2472	102.95	-	-	98.1	32.45	7.4	35	136	239	P	H
	*	2472	95.03	-	-	90.18	32.45	7.4	35	136	239	A	H
		2483.64	66.76	-7.24	74	61.91	32.45	7.4	35	136	239	P	H
		2483.52	51.42	-2.58	54	46.57	32.45	7.4	35	136	239	A	H
	*	2472	102.63	-	-	97.78	32.45	7.4	35	319	263	P	V
	*	2472	94.81	-	-	89.96	32.45	7.4	35	319	263	A	V
		2483.68	67.9	-6.1	74	63.05	32.45	7.4	35	319	263	P	V
		2483.52	52.23	-1.77	54	47.38	32.45	7.4	35	319	263	A	V
Remark	1. No other spurious found. 2. All results are PASS against Peak and Average limit line.												



2.4GHz 2400~2483.5MHz

WIFI 802.11n HT20 (Harmonic @ 3m)

WIFI Ant. 1	Note	Frequency (MHz)	Level (dBμV/m)	Over Limit (dB)	Limit Line (dBμV/m)	Read Level (dBμV)	Antenna Factor (dB/m)	Cable Loss (dB)	Preamp Factor (dB)	Ant Pos (cm)	Table Pos (deg)	Peak Avg. (P/A)	Pol. (H/V)
802.11n HT20 CH 01 2412MHz		4824	46.95	-27.05	74	60.67	33.64	11.68	59.04	100	0	P	H
		4824	45.4	-28.6	74	59.12	33.64	11.68	59.04	100	0	P	V
802.11n HT20 CH 06 2437MHz		4878	45.85	-28.15	74	59.72	33.54	11.53	58.94	100	0	P	H
		7311	39.84	-34.16	74	49.27	34.69	13.81	57.93	100	0	P	H
		4878	44.09	-29.91	74	57.96	33.54	11.53	58.94	100	0	P	V
		7311	39.58	-34.42	74	49.01	34.69	13.81	57.93	100	0	P	V
802.11n HT20 CH 11 2462MHz		4926	47.77	-26.23	74	61.8	33.44	11.37	58.84	100	0	P	H
		7386	38.31	-35.69	74	47.95	34.47	13.95	58.06	100	0	P	H
		4926	42.62	-31.38	74	56.65	33.44	11.37	58.84	100	0	P	V
		7386	39.7	-34.3	74	49.34	34.47	13.95	58.06	100	0	P	V
802.11n HT20 CH 12 2467MHz		4934	44.44	-29.56	74	58.47	33.44	11.37	58.84	100	0	P	H
		7401	39.79	-34.21	74	49.5	34.42	13.95	58.08	100	0	P	H
		4934	40.94	-33.06	74	54.97	33.44	11.37	58.84	100	0	P	V
		7401	39.9	-34.1	74	49.61	34.42	13.95	58.08	100	0	P	V
802.11n HT20 CH 13 2472MHz		4944	41.53	-32.47	74	55.71	33.4	11.22	58.8	100	0	P	H
		7416	38.37	-35.63	74	48.08	34.42	13.95	58.08	100	0	P	H
		4944	40.98	-33.02	74	55.16	33.4	11.22	58.8	100	0	P	V
		7416	38.53	-35.47	74	48.24	34.42	13.95	58.08	100	0	P	V
Remark	1. No other spurious found. 2. All results are PASS against Peak and Average limit line.												



Emission below 1GHz

2.4GHz WIFI 802.11g (LF)

WIFI	Note	Frequency	Level	Over	Limit	Read	Antenna	Cable	Preamp	Ant	Table	Peak	Pol.
Ant.				Limit	Line	Level	Factor	Loss	Factor	Pos	Pos	Avg.	
1		(MHz)	(dBμV/m)	(dB)	(dBμV/m)	(dBμV)	(dB/m)	(dB)	(dB)	(cm)	(deg)	(P/A)	(H/V)
2.4GHz 802.11g LF		85.62	28.24	-11.76	40	44	14.5	1.28	31.54	100	0	P	H
		114.78	30.66	-12.84	43.5	43.05	17.57	1.55	31.51	-	-	P	H
		246.27	27.52	-18.48	46	38.19	18.64	2.07	31.38	-	-	P	H
		339.9	27.89	-18.11	46	35.81	20.9	2.41	31.23	-	-	P	H
		855.1	32.22	-13.78	46	29.95	28.73	4.1	30.56	-	-	P	H
		958.7	33.12	-12.88	46	29.36	30.22	4.07	30.53	-	-	P	H
		49.98	33.88	-6.12	40	49.31	15.1	1.07	31.6	100	0	P	V
		109.11	27.34	-16.16	43.5	40.01	17.3	1.55	31.52	-	-	P	V
		257.61	24.25	-21.75	46	33.74	19.8	2.07	31.36	-	-	P	V
		795.6	30.8	-15.2	46	29.85	27.65	3.9	30.6	-	-	P	V
		884.5	32.14	-13.86	46	29.61	28.91	4.17	30.55	-	-	P	V
	942.6	32.56	-13.44	46	28.98	30.04	4.07	30.53	-	-	P	V	
Remark	1. No other spurious found. 2. All results are PASS against limit line.												



Note symbol

*	Fundamental Frequency which can be ignored. However, the level of any unwanted emissions shall not exceed the level of the fundamental frequency.
!	Test result is over limit line.
P/A	Peak or Average
H/V	Horizontal or Vertical



A calculation example for radiated spurious emission is shown as below:

WIFI	Note	Frequency	Level	Over	Limit	Read	Antenna	Cable	Preamp	Ant	Table	Peak	Pol.
Ant.				Limit	Line	Level	Factor	Loss	Factor	Pos	Pos	Avg.	
1		(MHz)	(dBμV/m)	(dB)	(dBμV/m)	(dBμV)	(dB/m)	(dB)	(dB)	(cm)	(deg)	(P/A)	(H/V)
802.11b		2390	55.45	-18.55	74	54.51	32.22	4.58	35.86	103	308	P	H
CH 01													
2412MHz		2390	43.54	-10.46	54	42.6	32.22	4.58	35.86	103	308	A	H

- 1. Level(dBμV/m) =
Antenna Factor(dB/m) + Cable Loss(dB) + Read Level(dBμV) - Preamp Factor(dB)
- 2. Over Limit(dB) = Level(dBμV/m) – Limit Line(dBμV/m)

For Peak Limit @ 2390MHz:

- 1. Level(dBμV/m)
= Antenna Factor(dB/m) + Cable Loss(dB) + Read Level(dBμV) - Preamp Factor(dB)
= 32.22(dB/m) + 4.58(dB) + 54.51(dBμV) – 35.86 (dB)
= 55.45 (dBμV/m)
- 2. Over Limit(dB)
= Level(dBμV/m) – Limit Line(dBμV/m)
= 55.45(dBμV/m) – 74(dBμV/m)
= -18.55(dB)

For Average Limit @ 2390MHz:

- 1. Level(dBμV/m)
= Antenna Factor(dB/m) + Cable Loss(dB) + Read Level(dBμV) - Preamp Factor(dB)
= 32.22(dB/m) + 4.58(dB) + 42.6(dBμV) – 35.86 (dB)
= 43.54 (dBμV/m)
- 2. Over Limit(dB)
= Level(dBμV/m) – Limit Line(dBμV/m)
= 43.54(dBμV/m) – 54(dBμV/m)
= -10.46(dB)

Both peak and average measured complies with the limit line, so test result is “PASS”.



Appendix C. Radiated Spurious Emission Plots

Test Engineer :	Jesse Wang, James Chiu, and Daniel Lee	Temperature :	21~22°C
		Relative Humidity :	44~48%

Note symbol

-L	Low channel location
-R	High channel location



2.4GHz 2400~2483.5MHz

WIFI 802.11b (Band Edge @ 3m)

WIFI	2.4GHz 2400~2483.5MHz Band Edge @ 3m	
ANT	802.11b CH01 2412MHz	
1	Horizontal	Fundamental
Peak	<p>Site : 03CH07-FY Condition : PEAK_BE_74 3m HF-ANT_130829 HORIZONTAL REW: 1000 000kHz VBW: 3000 000kHz SWT: Auto Detector : Peak Project : 671336-01 Mode : 7</p>	<p>Site : 03CH07-FY Condition : PEAK_74 3m HF-ANT_130829 HORIZONTAL REW: 1000 000kHz VBW: 3000 000kHz SWT: Auto Detector : Peak Project : 671336-01 Mode : 7</p>
Avg.	<p>Site : 03CH07-FY Condition : AVG_BE_74 3m HF-ANT_130829 HORIZONTAL REW: 1000 000kHz VBW: 0 018kHz SWT: Auto Detector : Peak Project : 671336-01 Mode : 7</p>	<p>Site : 03CH07-FY Condition : AVG_54 3m HF-ANT_130829 HORIZONTAL REW: 1000 000kHz VBW: 0 018kHz SWT: Auto Detector : Peak Project : 671336-01 Mode : 7</p>

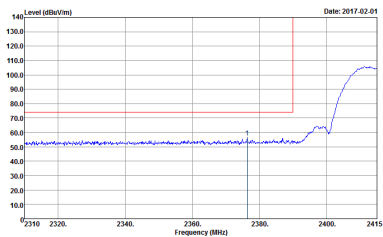
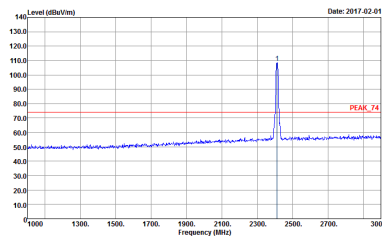
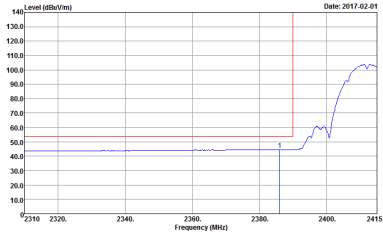
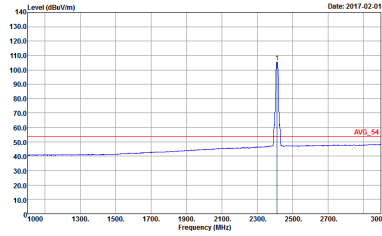

WIFI	2.4GHz 2400~2483.5MHz Band Edge @ 3m	
ANT	802.11b CH01 2412MHz	
1	Vertical	Fundamental
Peak	 <p>Date: 2017.02.01</p> <p>Site : 03CH074Y Condition : PEAK_BE_74 3m HF-ANT_130829 VERTICAL RBW:1000 000kHz VBW:3000 000kHz SWT:Auto Detector : Peak Project : 671336-01 Mode : 7</p>	 <p>Date: 2017.02.01</p> <p>Site : 03CH074Y Condition : PEAK_74 3m HF-ANT_130829 VERTICAL RBW:1000 000kHz VBW:3000 000kHz SWT:Auto Detector : Peak Project : 671336-01 Mode : 7</p>
Avg.	 <p>Date: 2017.02.01</p> <p>Site : 03CH074Y Condition : AVG_BE_54 3m HF-ANT_130829 VERTICAL RBW:1000 000kHz VBW:0 010kHz SWT:Auto Detector : Peak Project : 671336-01 Mode : 7</p>	 <p>Date: 2017.02.01</p> <p>Site : 03CH074Y Condition : AVG_54 3m HF-ANT_130829 VERTICAL RBW:1000 000kHz VBW:0 010kHz SWT:Auto Detector : Peak Project : 671336-01 Mode : 7</p>

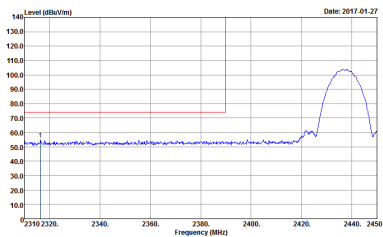
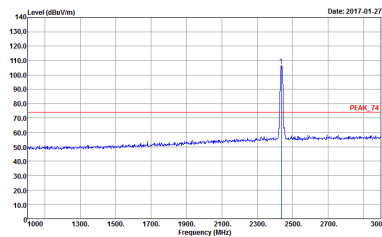
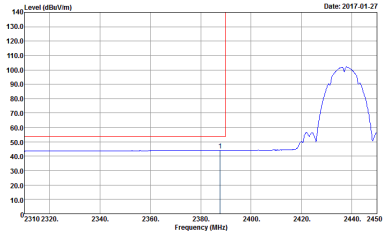
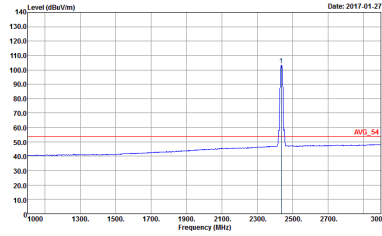

WIFI	2.4GHz 2400~2483.5MHz Band Edge @ 3m	
ANT	802.11b CH06 2437MHz - L	
1	Horizontal	Fundamental
Peak	 <p>Site : 03CH074Y Condition : PEAK_BE_74 3m HF-ANT_130829 HORIZONTAL Detector : Peak Project : 671336-01 Mode : 8</p>	 <p>Site : 03CH074Y Condition : PEAK_74 3m HF-ANT_130829 HORIZONTAL Detector : Peak Project : 671336-01 Mode : 8</p>
Avg.	 <p>Site : 03CH074Y Condition : AVG_BE_54 3m HF-ANT_130829 HORIZONTAL Detector : Peak Project : 671336-01 Mode : 8</p>	 <p>Site : 03CH074Y Condition : AVG_54 3m HF-ANT_130829 HORIZONTAL Detector : Peak Project : 671336-01 Mode : 8</p>

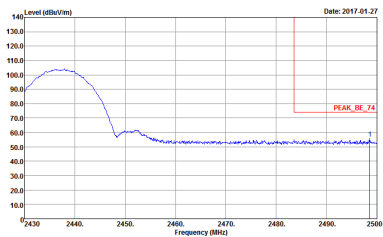
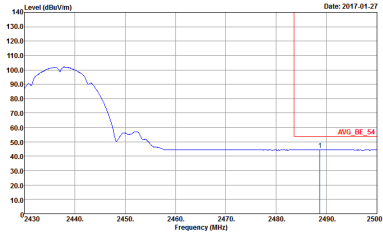

WIFI	2.4GHz 2400~2483.5MHz Band Edge @ 3m	
ANT	802.11b CH06 2437MHz - R	
1	Horizontal	Fundamental
<p>Peak</p>	 <p>Date: 2017.01.27</p> <p>Site : 03CH074Y Condition : PEAK_BE_74 3m HF-ANT_130829 HORIZONTAL Detector : Peak Project : 671336-01 Mode : 0</p>	<p>Left blank</p>
<p>Avg.</p>	 <p>Date: 2017.01.27</p> <p>Site : 03CH074Y Condition : AVG_BE_54 3m HF-ANT_130829 HORIZONTAL Detector : Peak Project : 671336-01 Mode : 0</p>	<p>Left blank</p>

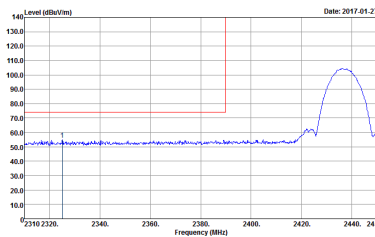
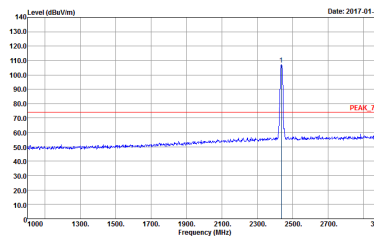
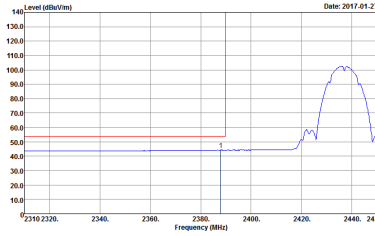
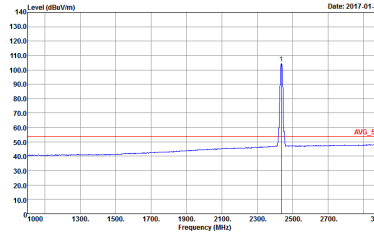

WIFI	2.4GHz 2400~2483.5MHz Band Edge @ 3m	
ANT	802.11b CH06 2437MHz - L	
1	Vertical	Fundamental
Peak	 <p>Date: 2017-01-27</p> <p>Site : 03CH074Y Condition : PEAK_BE_74 3m HF-ANT_130829 VERTICAL Detector : Peak Project : 671336-01 Mode : 0</p>	 <p>Date: 2017-01-27</p> <p>Site : 03CH074Y Condition : PEAK_74 3m HF-ANT_130829 VERTICAL Detector : Peak Project : 671336-01 Mode : 0</p>
Avg.	 <p>Date: 2017-01-27</p> <p>Site : 03CH074Y Condition : AVG_BE_54 3m HF-ANT_130829 VERTICAL Detector : Peak Project : 671336-01 Mode : 0</p>	 <p>Date: 2017-01-27</p> <p>Site : 03CH074Y Condition : AVG_54 3m HF-ANT_130829 VERTICAL Detector : Peak Project : 671336-01 Mode : 0</p>

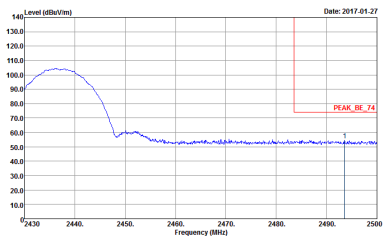
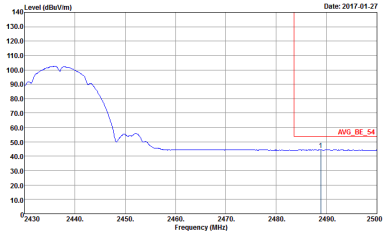

WIFI	2.4GHz 2400~2483.5MHz Band Edge @ 3m	
ANT	802.11b CH06 2437MHz - R	
1	Vertical	Fundamental
<p>Peak</p>	 <p>Site : 63CH074Y Condition : PEAK_BE_74 3m HF-ANT_130829 VERTICAL Detector : Peak Project : 671336-01 Mode : 0</p>	<p>Left blank</p>
<p>Avg.</p>	 <p>Site : 63CH074Y Condition : AVG_BE_54 3m HF-ANT_130829 VERTICAL Detector : Peak Project : 671336-01 Mode : 0</p>	<p>Left blank</p>

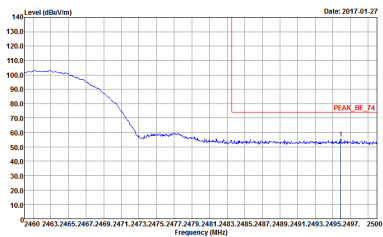
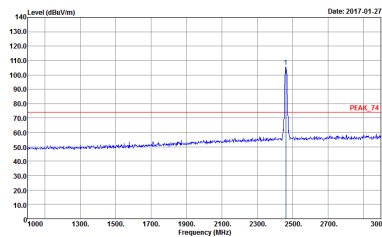
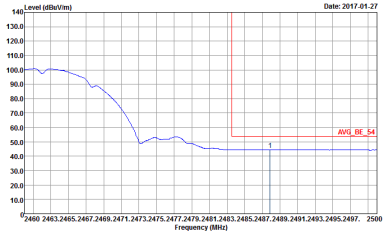
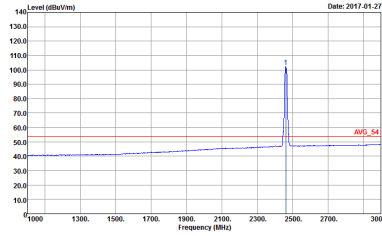

WIFI	2.4GHz 2400~2483.5MHz Band Edge @ 3m	
ANT	802.11b CH11 2462MHz	
1	Horizontal	Fundamental
Peak	 <p>Level (dBm/1m) vs Frequency (MHz) plot for Horizontal orientation. The plot shows a signal level starting at approximately 100 dBm/1m at 2400 MHz and decreasing to about 50 dBm/1m by 2462 MHz. A red vertical line marks the peak at 2462 MHz, labeled 'PEAK_BE_74'. The x-axis ranges from 2460 to 2500 MHz, and the y-axis ranges from 10.0 to 140.0 dBm/1m.</p> <p>Site : 03CH07-1Y Condition : PEAK_BE_74 3m HF-ANT_130829 HORIZONTAL Detector : Peak Project : 671336-01 Mode : 9</p>	 <p>Level (dBm/1m) vs Frequency (MHz) plot for Fundamental orientation. The plot shows a sharp peak at 2462 MHz with a level of approximately 100 dBm/1m. A red vertical line marks the peak, labeled 'PEAK_74'. The x-axis ranges from 1000 to 3000 MHz, and the y-axis ranges from 10.0 to 140.0 dBm/1m.</p> <p>Site : 03CH07-1Y Condition : PEAK_74 3m HF-ANT_130829 HORIZONTAL Detector : Peak Project : 671336-01 Mode : 9</p>
Avg.	 <p>Level (dBm/1m) vs Frequency (MHz) plot for Horizontal orientation. The plot shows a signal level starting at approximately 100 dBm/1m at 2400 MHz and decreasing to about 50 dBm/1m by 2462 MHz. A red vertical line marks the average level at 2462 MHz, labeled 'AVG_BE_54'. The x-axis ranges from 2460 to 2500 MHz, and the y-axis ranges from 10.0 to 140.0 dBm/1m.</p> <p>Site : 03CH07-1Y Condition : AVG_BE_54 3m HF-ANT_130829 HORIZONTAL Detector : Peak Project : 671336-01 Mode : 9</p>	 <p>Level (dBm/1m) vs Frequency (MHz) plot for Fundamental orientation. The plot shows a sharp peak at 2462 MHz with an average level of approximately 100 dBm/1m. A red vertical line marks the average level, labeled 'AVG_54'. The x-axis ranges from 1000 to 3000 MHz, and the y-axis ranges from 10.0 to 140.0 dBm/1m.</p> <p>Site : 03CH07-1Y Condition : AVG_54 3m HF-ANT_130829 HORIZONTAL Detector : Peak Project : 671336-01 Mode : 9</p>

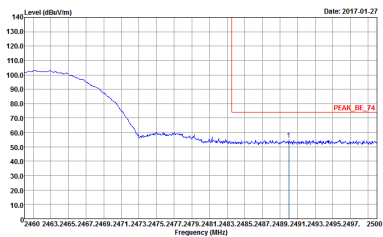
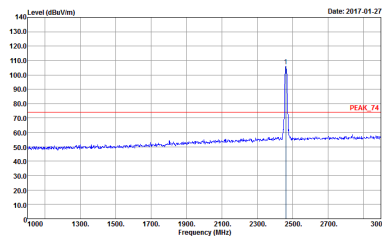
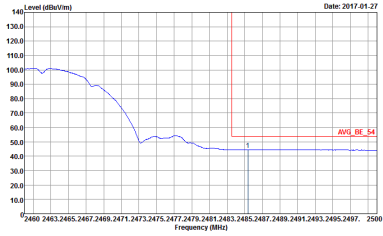
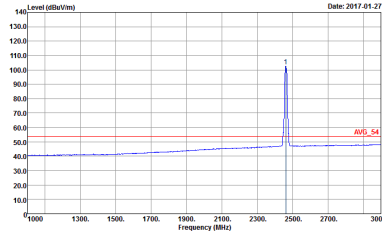

WIFI	2.4GHz 2400~2483.5MHz Band Edge @ 3m	
ANT	802.11b CH11 2462MHz	
1	Vertical	Fundamental
Peak	 <p>Level (dBm/Vm) vs Frequency (MHz) plot for Peak Vertical. The plot shows a signal level starting at approximately 100 dBm/Vm at 2400 MHz and decreasing to about 50 dBm/Vm by 2462 MHz. A red line indicates the peak level at 2462 MHz, labeled 'PEAK_BE_74'.</p> <p>Site : 03CH074Y Condition : PEAK_BE_74 3m HF-ANT_130829 VERTICAL RBW: 1000.000kHz VBW: 3000.000kHz SWT: Auto Detector : Peak Project : 671336-01 Mode : 9</p>	 <p>Level (dBm/Vm) vs Frequency (MHz) plot for Peak Fundamental. The plot shows a sharp peak at 2462 MHz with a level of approximately 100 dBm/Vm. A red line indicates the peak level, labeled 'PEAK_74'.</p> <p>Site : 03CH074Y Condition : PEAK_74 3m HF-ANT_130829 VERTICAL RBW: 1000.000kHz VBW: 3000.000kHz SWT: Auto Detector : Peak Project : 671336-01 Mode : 9</p>
Avg.	 <p>Level (dBm/Vm) vs Frequency (MHz) plot for Avg Vertical. The plot shows a signal level starting at approximately 100 dBm/Vm at 2400 MHz and decreasing to about 50 dBm/Vm by 2462 MHz. A red line indicates the average level at 2462 MHz, labeled 'AVG_BE_54'.</p> <p>Site : 03CH074Y Condition : AVG_BE_54 3m HF-ANT_130829 VERTICAL RBW: 1000.000kHz VBW: 0.010kHz SWT: Auto Detector : Peak Project : 671336-01 Mode : 9</p>	 <p>Level (dBm/Vm) vs Frequency (MHz) plot for Avg Fundamental. The plot shows a sharp peak at 2462 MHz with a level of approximately 100 dBm/Vm. A red line indicates the average level, labeled 'AVG_54'.</p> <p>Site : 03CH074Y Condition : AVG_54 3m HF-ANT_130829 VERTICAL RBW: 1000.000kHz VBW: 0.010kHz SWT: Auto Detector : Peak Project : 671336-01 Mode : 9</p>

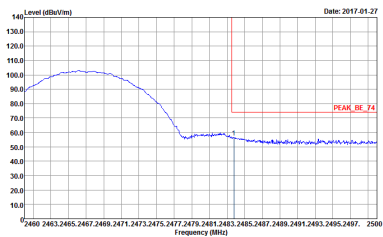
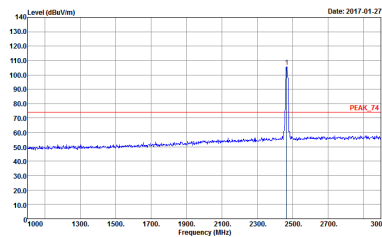
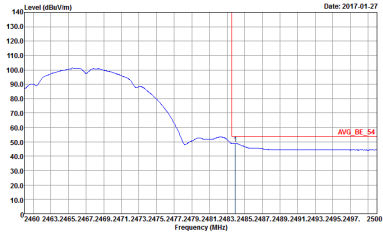
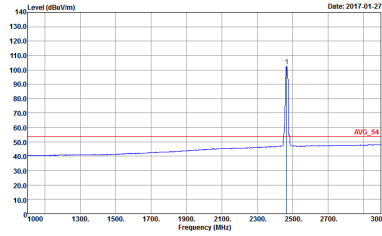

WIFI	2.4GHz 2400~2483.5MHz Band Edge @ 3m	
ANT	802.11b CH12 2467MHz	
1	Horizontal	Fundamental
Peak	 <p>Level (dBm/100kHz) vs Frequency (MHz) plot for Horizontal polarization. The plot shows a signal level starting at approximately 90 dBm/100kHz at 2400 MHz, peaking around 105 dBm/100kHz near 2467 MHz, and then dropping to about 55 dBm/100kHz by 2483.5 MHz. A red vertical line marks the peak at 2467 MHz, labeled 'PEAK_BE_74'.</p> <p>Site : 03CH074Y Condition : PEAK_BE_74 3m HF-ANT_130829 HORIZONTAL Detector : Peak Project : 671336-01 Mode : 10</p>	 <p>Level (dBm/100kHz) vs Frequency (MHz) plot for Fundamental polarization. The plot shows a flat noise floor at approximately 55 dBm/100kHz from 1000 MHz to 2400 MHz. A sharp peak is observed at 2467 MHz, reaching approximately 110 dBm/100kHz. A red vertical line marks this peak, labeled 'PEAK_74'.</p> <p>Site : 03CH074Y Condition : PEAK_74 3m HF-ANT_130829 HORIZONTAL Detector : Peak Project : 671336-01 Mode : 10</p>
Avg.	 <p>Level (dBm/100kHz) vs Frequency (MHz) plot for Horizontal polarization, averaged. The plot shows a signal level starting at approximately 90 dBm/100kHz at 2400 MHz, peaking around 105 dBm/100kHz near 2467 MHz, and then dropping to about 55 dBm/100kHz by 2483.5 MHz. A red vertical line marks the peak at 2467 MHz, labeled 'AVG_BE_54'.</p> <p>Site : 03CH074Y Condition : AVG_BE_54 3m HF-ANT_130829 HORIZONTAL Detector : Peak Project : 671336-01 Mode : 10</p>	 <p>Level (dBm/100kHz) vs Frequency (MHz) plot for Fundamental polarization, averaged. The plot shows a flat noise floor at approximately 55 dBm/100kHz from 1000 MHz to 2400 MHz. A sharp peak is observed at 2467 MHz, reaching approximately 110 dBm/100kHz. A red vertical line marks this peak, labeled 'AVG_54'.</p> <p>Site : 03CH074Y Condition : AVG_54 3m HF-ANT_130829 HORIZONTAL Detector : Peak Project : 671336-01 Mode : 10</p>

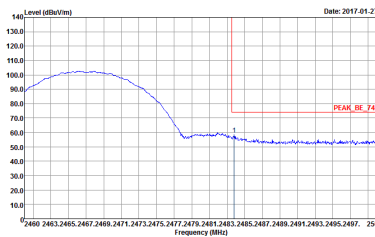
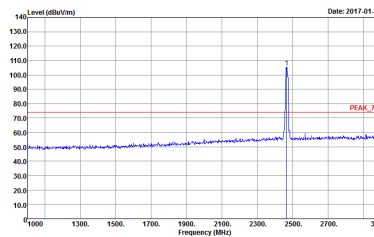
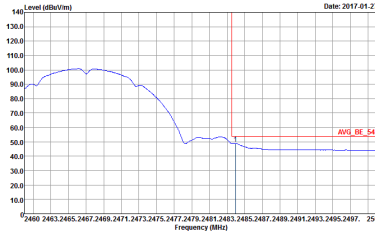
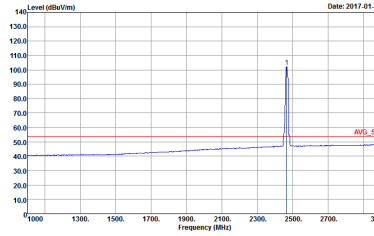

WIFI	2.4GHz 2400~2483.5MHz Band Edge @ 3m	
ANT	802.11b CH12 2467MHz	
1	Vertical	Fundamental
Peak	 <p>Date: 2017-01-27</p> <p>Site : 03CH074Y Condition : PEAK_BE_74 3m HF-ANT_130829 VERTICAL RBW: 1000 000kHz VBW: 3000 000kHz SWT: Auto Detector : Peak Project : 671336-01 Mode : 10</p>	 <p>Date: 2017-01-27</p> <p>Site : 03CH074Y Condition : PEAK_74 3m HF-ANT_130829 VERTICAL RBW: 1000 000kHz VBW: 3000 000kHz SWT: Auto Detector : Peak Project : 671336-01 Mode : 10</p>
Avg.	 <p>Date: 2017-01-27</p> <p>Site : 03CH074Y Condition : AVG_BE_54 3m HF-ANT_130829 VERTICAL RBW: 1000 000kHz VBW: 0 0100kHz SWT: Auto Detector : Peak Project : 671336-01 Mode : 10</p>	 <p>Date: 2017-01-27</p> <p>Site : 03CH074Y Condition : AVG_54 3m HF-ANT_130829 VERTICAL RBW: 1000 000kHz VBW: 0 0100kHz SWT: Auto Detector : Peak Project : 671336-01 Mode : 10</p>

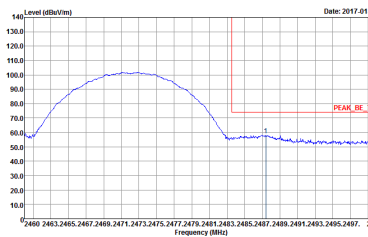
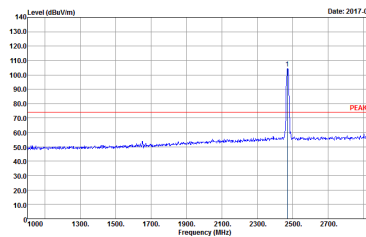
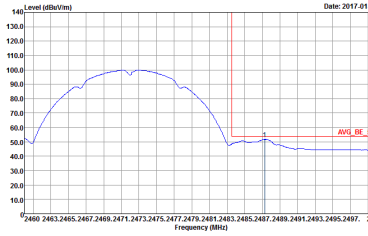
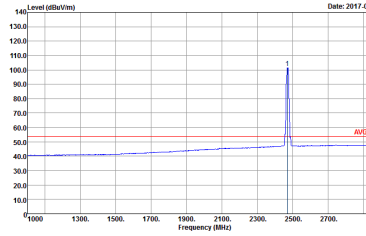

WIFI	2.4GHz 2400~2483.5MHz Band Edge @ 3m	
ANT	802.11b CH13 2472MHz	
1	Horizontal	Fundamental
Peak	 <p>Level (dBm/100MHz) vs Frequency (MHz) plot showing a peak at 2472 MHz labeled PEAK_BE_74. The y-axis ranges from 10.0 to 140.0 dBm/100MHz, and the x-axis ranges from 2460 to 2500 MHz.</p> <p>Site : 03CH07-1Y Condition : PEAK_BE_74 3m HF-ANT_130829 HORIZONTAL RBW: 1000.000kHz VBW: 3000.000kHz SWT: Auto Detector : Peak Project : 671336-01 Mode : 11 : 13</p>	 <p>Level (dBm/100MHz) vs Frequency (MHz) plot showing a sharp peak at 2472 MHz labeled PEAK_74. The y-axis ranges from 10.0 to 140.0 dBm/100MHz, and the x-axis ranges from 1000 to 3000 MHz.</p> <p>Site : 03CH07-1Y Condition : PEAK_74 3m HF-ANT_130829 HORIZONTAL RBW: 1000.000kHz VBW: 3000.000kHz SWT: Auto Detector : Peak Project : 671336-01 Mode : 11 : 13</p>
Avg.	 <p>Level (dBm/100MHz) vs Frequency (MHz) plot showing an average signal at 2472 MHz labeled AVG_BE_54. The y-axis ranges from 10.0 to 140.0 dBm/100MHz, and the x-axis ranges from 2460 to 2500 MHz.</p> <p>Site : 03CH07-1Y Condition : AVG_BE_54 3m HF-ANT_130829 HORIZONTAL RBW: 1000.000kHz VBW: 0.010kHz SWT: Auto Detector : Peak Project : 671336-01 Mode : 11 : 13</p>	 <p>Level (dBm/100MHz) vs Frequency (MHz) plot showing an average signal at 2472 MHz labeled AVG_54. The y-axis ranges from 10.0 to 140.0 dBm/100MHz, and the x-axis ranges from 1000 to 3000 MHz.</p> <p>Site : 03CH07-1Y Condition : AVG_54 3m HF-ANT_130829 HORIZONTAL RBW: 1000.000kHz VBW: 0.010kHz SWT: Auto Detector : Peak Project : 671336-01 Mode : 11 : 13</p>



WIFI	2.4GHz 2400~2483.5MHz Band Edge @ 3m	
ANT	802.11b CH13 2472MHz	
1	Vertical	Fundamental
Peak	<p>Site : 03CH074Y Condition : PEAK_BE_74 3m HF-ANT_130829 VERTICAL RBW:1000.000kHz VBW:3000.000kHz SWT:Auto Detector : Peak Project : 671336-01 Mode : 11 : 13</p>	<p>Site : 03CH074Y Condition : PEAK_74 3m HF-ANT_130829 VERTICAL RBW:1000.000kHz VBW:3000.000kHz SWT:Auto Detector : Peak Project : 671336-01 Mode : 11 : 13</p>
Avg.	<p>Site : 03CH074Y Condition : AVG_BE_54 3m HF-ANT_130829 VERTICAL RBW:1000.000kHz VBW:0.010kHz SWT:Auto Detector : Peak Project : 671336-01 Mode : 11 : 13</p>	<p>Site : 03CH074Y Condition : AVG_54 3m HF-ANT_130829 VERTICAL RBW:1000.000kHz VBW:0.010kHz SWT:Auto Detector : Peak Project : 671336-01 Mode : 11 : 13</p>



2.4GHz 2400~2483.5MHz

WIFI 802.11g (Band Edge @ 3m)

WIFI	2.4GHz 2400~2483.5MHz Band Edge @ 3m	
ANT	802.11g CH01 2412MHz	
1	Horizontal	Fundamental
Peak	<p>Site : 03CH07-FY Condition : PEAK_BE_74 3m HF-ANT_130829 HORIZONTAL REW:1000 000kHz VBW:3000 000kHz SWT:Auto Detector : Peak Project : 671336-01 Mode : 12</p>	<p>Site : 03CH07-FY Condition : PEAK_74 3m HF-ANT_130829 HORIZONTAL REW:1000 000kHz VBW:3000 000kHz SWT:Auto Detector : Peak Project : 671336-01 Mode : 12</p>
Avg.	<p>Site : 03CH07-FY Condition : AVG_BE_74 3m HF-ANT_130829 HORIZONTAL REW:1000 000kHz VBW:1.000kHz SWT:Auto Detector : Peak Project : 671336-01 Mode : 12</p>	<p>Site : 03CH07-FY Condition : AVG_54 3m HF-ANT_130829 HORIZONTAL REW:1000 000kHz VBW:1.000kHz SWT:Auto Detector : Peak Project : 671336-01 Mode : 12</p>

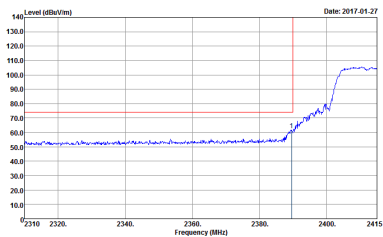
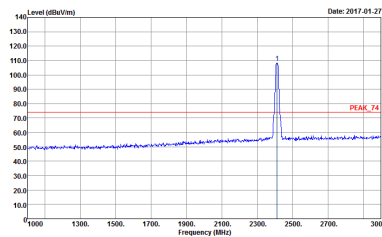
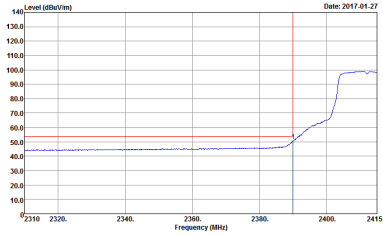
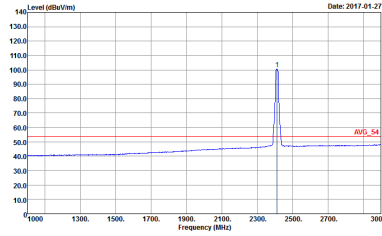

WIFI	2.4GHz 2400~2483.5MHz Band Edge @ 3m	
ANT	802.11g CH01 2412MHz	
1	Vertical	Fundamental
Peak	 <p>Site : 03CH074Y Condition : PEAK_BE_74 3m HF-ANT_130829 VERTICAL RBW:1000.000kHz VBW:3000.000kHz SWT:Auto Detector : Peak Project : 671336-01 Mode : 12</p>	 <p>Site : 03CH074Y Condition : PEAK_74 3m HF-ANT_130829 VERTICAL RBW:1000.000kHz VBW:3000.000kHz SWT:Auto Detector : Peak Project : 671336-01 Mode : 12</p>
Avg.	 <p>Site : 03CH074Y Condition : AVG_BE_54 3m HF-ANT_130829 VERTICAL RBW:1000.000kHz VBW:1.000kHz SWT:Auto Detector : Peak Project : 671336-01 Mode : 12</p>	 <p>Site : 03CH074Y Condition : AVG_54 3m HF-ANT_130829 VERTICAL RBW:1000.000kHz VBW:1.000kHz SWT:Auto Detector : Peak Project : 671336-01 Mode : 12</p>

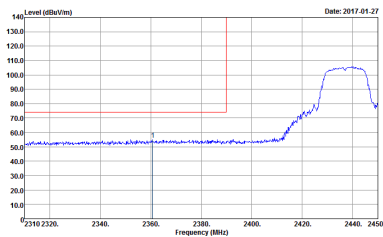
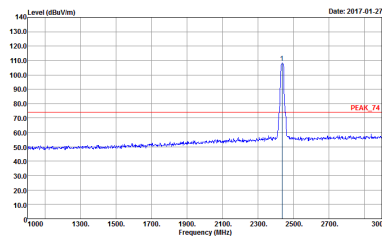
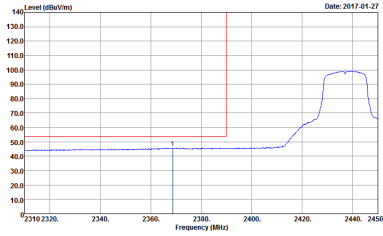
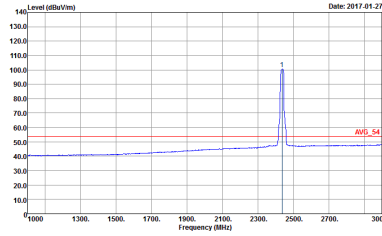

WIFI	2.4GHz 2400~2483.5MHz Band Edge @ 3m	
ANT	802.11g CH06 2437MHz - L	
1	Horizontal	Fundamental
Peak	 <p>Level (dBm/1m) vs Frequency (MHz) plot for Horizontal orientation. The plot shows a signal rising from approximately 50 dBm/1m at 2380 MHz to a peak of about 105 dBm/1m at 2437 MHz. A red vertical line marks the peak frequency. Metadata includes: Site: 03CH07-1Y, Condition: PEAK_BE_74 3m HF-ANT_130829 HORIZONTAL, Detector: Peak, Project: 671336-01, Mode: 13.</p>	 <p>Level (dBm/1m) vs Frequency (MHz) plot for Fundamental orientation. The plot shows a sharp peak at 2437 MHz with a level of approximately 105 dBm/1m. A red horizontal line is labeled 'PEAK_74'. Metadata includes: Site: 03CH07-1Y, Condition: PEAK_74 3m HF-ANT_130829 HORIZONTAL, Detector: Peak, Project: 671336-01, Mode: 13.</p>
Avg.	 <p>Level (dBm/1m) vs Frequency (MHz) plot for Horizontal orientation, averaged. The plot shows a signal rising from approximately 50 dBm/1m at 2380 MHz to a peak of about 100 dBm/1m at 2437 MHz. Metadata includes: Site: 03CH07-1Y, Condition: AVG_BE_54 3m HF-ANT_130829 HORIZONTAL, Detector: Peak, Project: 671336-01, Mode: 13.</p>	 <p>Level (dBm/1m) vs Frequency (MHz) plot for Fundamental orientation, averaged. The plot shows a sharp peak at 2437 MHz with a level of approximately 100 dBm/1m. A red horizontal line is labeled 'AVG_54'. Metadata includes: Site: 03CH07-1Y, Condition: AVG_54 3m HF-ANT_130829 HORIZONTAL, Detector: Peak, Project: 671336-01, Mode: 13.</p>



WIFI	2.4GHz 2400~2483.5MHz Band Edge @ 3m	
ANT	802.11g CH06 2437MHz - R	
1	Horizontal	Fundamental
Peak	<p>Site : 03CH07-1Y Condition : PEAK_BE_74 3m HF-ANT_130829 HORIZONTAL Detector : Peak Project : 671336-01 Mode : 13</p>	Left blank
Avg.	<p>Site : 03CH07-1Y Condition : AVG_BE_54 3m HF-ANT_130829 HORIZONTAL Detector : Peak Project : 671336-01 Mode : 13</p>	Left blank

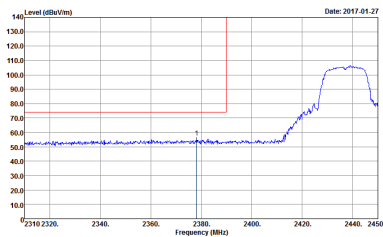
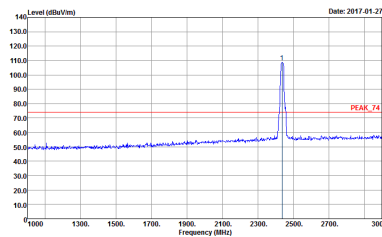
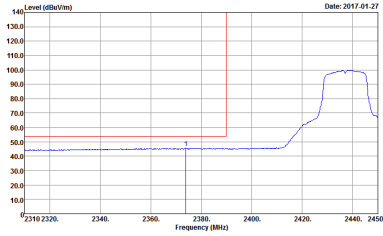
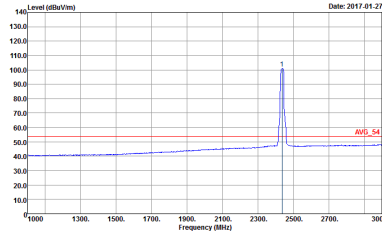

WIFI	2.4GHz 2400~2483.5MHz Band Edge @ 3m	
ANT	802.11g CH06 2437MHz - L	
1	Vertical	Fundamental
Peak	 <p>Date: 2017-01-27</p> <p>Site : 03CH07-HY Condition : PEAK_BE_74 3m HF-ANT_130829 VERTICAL Detector : RBW:1000.000kHz VEW:3000.000kHz SWT:Auto Project : 671336-01 Mode : 13</p>	 <p>Date: 2017-01-27</p> <p>Site : 03CH07-HY Condition : PEAK_74 3m HF-ANT_130829 VERTICAL Detector : RBW:1000.000kHz VEW:3000.000kHz SWT:Auto Project : 671336-01 Mode : 13</p>
Avg.	 <p>Date: 2017-01-27</p> <p>Site : 03CH07-HY Condition : AVG_BE_54 3m HF-ANT_130829 VERTICAL Detector : RBW:1000.000kHz VEW:1.000kHz SWT:Auto Project : 671336-01 Mode : 13</p>	 <p>Date: 2017-01-27</p> <p>Site : 03CH07-HY Condition : AVG_54 3m HF-ANT_130829 VERTICAL Detector : RBW:1000.000kHz VEW:1.000kHz SWT:Auto Project : 671336-01 Mode : 13</p>

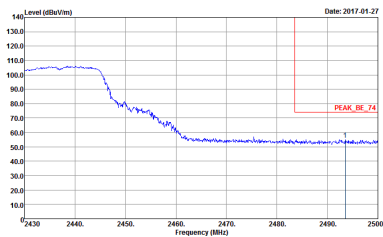
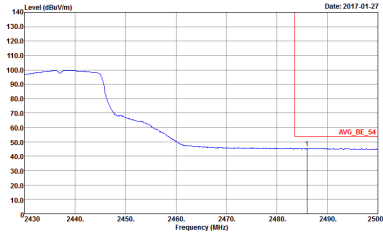

WIFI	2.4GHz 2400~2483.5MHz Band Edge @ 3m	
ANT	802.11g CH06 2437MHz - R	
1	Vertical	Fundamental
<p>Peak</p>	 <p>Site : 03CH07-1Y Condition : PEAK_BE_74 3m HF-ANT_130829 VERTICAL Detector : RBW:1000.000kHz VEW:3000.000kHz SWT:Auto Detector : Peak Project : 671336-01 Mode : 13</p>	<p>Left Blank</p>
<p>Avg.</p>	 <p>Site : 03CH07-1Y Condition : AVG_BE_54 3m HF-ANT_130829 VERTICAL Detector : RBW:1000.000kHz VEW:1.000kHz SWT:Auto Detector : Peak Project : 671336-01 Mode : 13</p>	<p>Left Blank</p>

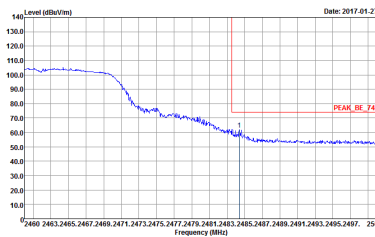
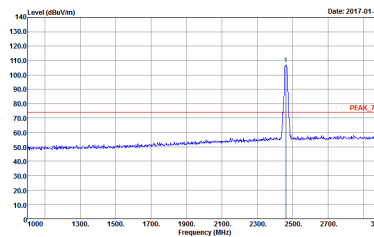
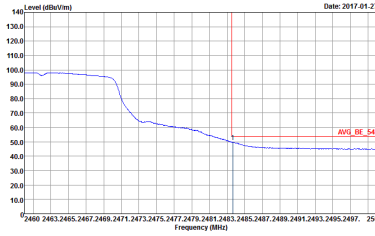
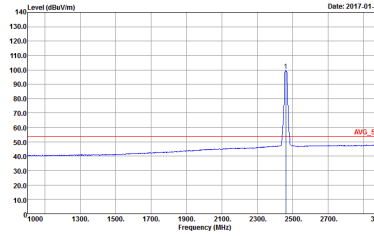

WIFI	2.4GHz 2400~2483.5MHz Band Edge @ 3m	
ANT	802.11g CH11 2462MHz	
1	Horizontal	Fundamental
Peak	 <p>Level (dBm/100MHz) vs Frequency (MHz) plot for Horizontal orientation. The plot shows a signal level starting at approximately 100 dBm/100MHz at 2400 MHz and decreasing to about 50 dBm/100MHz at 2483.5 MHz. A red vertical line marks the peak at 2462 MHz, labeled 'PEAK_BE_74'.</p> <p>Site : 03CH074Y Condition : PEAK_BE_74 3m HF-ANT_130829 HORIZONTAL Detector : Peak Project : 671336-01 Mode : 14</p>	 <p>Level (dBm/100MHz) vs Frequency (MHz) plot for Fundamental orientation. The plot shows a sharp peak at 2462 MHz with a level of approximately 110 dBm/100MHz. A red vertical line marks the peak, labeled 'PEAK_74'.</p> <p>Site : 03CH074Y Condition : PEAK_74 3m HF-ANT_130829 HORIZONTAL Detector : Peak Project : 671336-01 Mode : 14</p>
Avg.	 <p>Level (dBm/100MHz) vs Frequency (MHz) plot for Horizontal orientation. The plot shows the average signal level, similar to the peak plot but with a smoother curve. A red vertical line marks the average level at 2462 MHz, labeled 'AVG_BE_54'.</p> <p>Site : 03CH074Y Condition : AVG_BE_54 3m HF-ANT_130829 HORIZONTAL Detector : Peak Project : 671336-01 Mode : 14</p>	 <p>Level (dBm/100MHz) vs Frequency (MHz) plot for Fundamental orientation. The plot shows the average signal level, similar to the peak plot but with a smoother curve. A red vertical line marks the average level at 2462 MHz, labeled 'AVG_54'.</p> <p>Site : 03CH074Y Condition : AVG_54 3m HF-ANT_130829 HORIZONTAL Detector : Peak Project : 671336-01 Mode : 14</p>

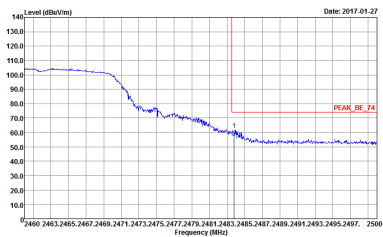
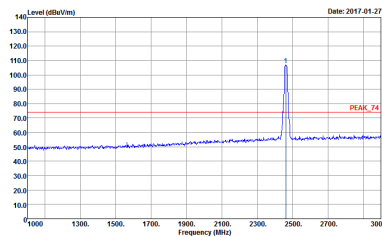
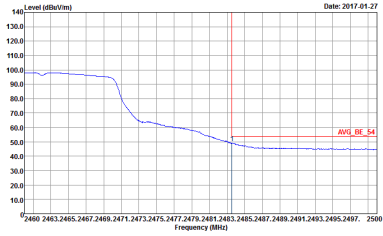
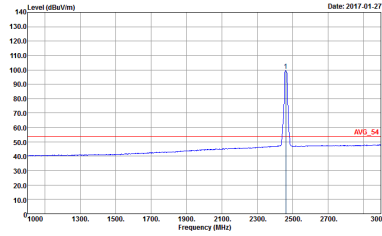

WIFI	2.4GHz 2400~2483.5MHz Band Edge @ 3m	
ANT	802.11g CH11 2462MHz	
1	Vertical	Fundamental
Peak	 <p>Date: 2017-01-27</p> <p>Site : 03CH074Y Condition : PEAK_BE_74 3m HF-ANT_130829 VERTICAL RBW: 1000.000kHz VBW: 3000.000kHz SWT: Auto Detector : Peak Project : 671336-01 Mode : 14</p>	 <p>Date: 2017-01-27</p> <p>Site : 03CH074Y Condition : PEAK_74 3m HF-ANT_130829 VERTICAL RBW: 1000.000kHz VBW: 3000.000kHz SWT: Auto Detector : Peak Project : 671336-01 Mode : 14</p>
Avg.	 <p>Date: 2017-01-27</p> <p>Site : 03CH074Y Condition : AVG_BE_54 3m HF-ANT_130829 VERTICAL RBW: 1000.000kHz VBW: 1.000kHz SWT: Auto Detector : Peak Project : 671336-01 Mode : 14</p>	 <p>Date: 2017-01-27</p> <p>Site : 03CH074Y Condition : AVG_54 3m HF-ANT_130829 VERTICAL RBW: 1000.000kHz VBW: 1.000kHz SWT: Auto Detector : Peak Project : 671336-01 Mode : 14</p>

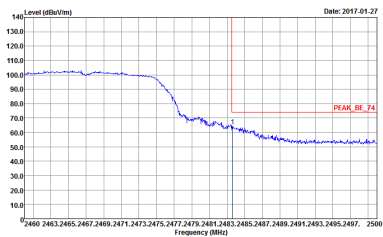
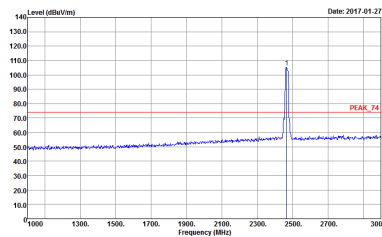
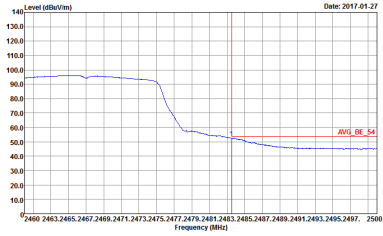
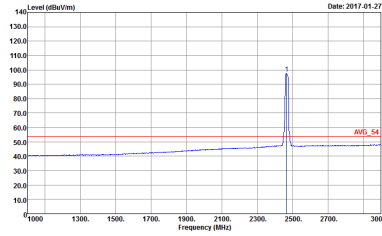

WIFI	2.4GHz 2400~2483.5MHz Band Edge @ 3m	
ANT	802.11g CH12 2467MHz	
1	Horizontal	Fundamental
Peak	 <p>Level (dBm/100kHz) vs Frequency (MHz) plot showing a peak at 2467 MHz. The y-axis ranges from 10.0 to 140.0 dBm/100kHz, and the x-axis ranges from 2460 to 2500 MHz. A red vertical line marks the peak at 2467 MHz, labeled 'PEAK_BE_74'.</p> <p>Site : 03CH074Y Condition : PEAK_BE_74 3m HF-ANT_130829 HORIZONTAL RBW: 1000.000kHz VBW: 3000.000kHz SWT: Auto Detector : Peak Project : 671336-01 Mode : 15 : 12</p>	 <p>Level (dBm/100kHz) vs Frequency (MHz) plot showing a peak at 2467 MHz. The y-axis ranges from 10.0 to 140.0 dBm/100kHz, and the x-axis ranges from 1000 to 3000 MHz. A red vertical line marks the peak at 2467 MHz, labeled 'PEAK_74'.</p> <p>Site : 03CH074Y Condition : PEAK_74 3m HF-ANT_130829 HORIZONTAL RBW: 1000.000kHz VBW: 3000.000kHz SWT: Auto Detector : Peak Project : 671336-01 Mode : 15 : 12</p>
Avg.	 <p>Level (dBm/100kHz) vs Frequency (MHz) plot showing an average level at 2467 MHz. The y-axis ranges from 10.0 to 140.0 dBm/100kHz, and the x-axis ranges from 2460 to 2500 MHz. A red vertical line marks the average level at 2467 MHz, labeled 'AVG_BE_54'.</p> <p>Site : 03CH074Y Condition : AVG_BE_54 3m HF-ANT_130829 HORIZONTAL RBW: 1000.000kHz VBW: 1.000kHz SWT: Auto Detector : Peak Project : 671336-01 Mode : 15 : 12</p>	 <p>Level (dBm/100kHz) vs Frequency (MHz) plot showing an average level at 2467 MHz. The y-axis ranges from 10.0 to 140.0 dBm/100kHz, and the x-axis ranges from 1000 to 3000 MHz. A red vertical line marks the average level at 2467 MHz, labeled 'AVG_54'.</p> <p>Site : 03CH074Y Condition : AVG_54 3m HF-ANT_130829 HORIZONTAL RBW: 1000.000kHz VBW: 1.000kHz SWT: Auto Detector : Peak Project : 671336-01 Mode : 15 : 12</p>

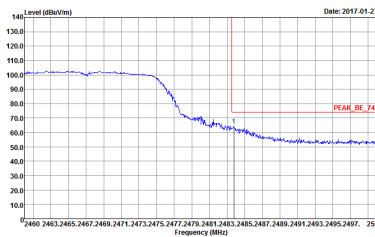
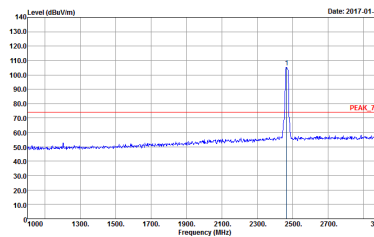
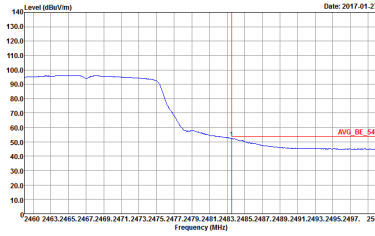
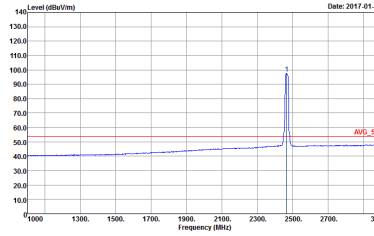

WIFI	2.4GHz 2400~2483.5MHz Band Edge @ 3m	
ANT	802.11g CH12 2467MHz	
1	Vertical	Fundamental
Peak	 <p>Date: 2017-01-27</p> <p>Level (dBV/m) vs Frequency (MHz)</p> <p>PEAK_BE_74</p> <p>Site : 03CH074Y Condition : PEAK_BE_74 3m HF-ANT_130829 VERTICAL RBW: 1000.000kHz VBW: 3000.000kHz SWT: Auto Detector : Peak Project : 671336-01 Mode : 15 : 12</p>	 <p>Date: 2017-01-27</p> <p>Level (dBV/m) vs Frequency (MHz)</p> <p>PEAK_74</p> <p>Site : 03CH074Y Condition : PEAK_74 3m HF-ANT_130829 VERTICAL RBW: 1000.000kHz VBW: 3000.000kHz SWT: Auto Detector : Peak Project : 671336-01 Mode : 15 : 12</p>
Avg.	 <p>Date: 2017-01-27</p> <p>Level (dBV/m) vs Frequency (MHz)</p> <p>AVG_BE_54</p> <p>Site : 03CH074Y Condition : AVG_BE_54 3m HF-ANT_130829 VERTICAL RBW: 1000.000kHz VBW: 1.000kHz SWT: Auto Detector : Peak Project : 671336-01 Mode : 15 : 12</p>	 <p>Date: 2017-01-27</p> <p>Level (dBV/m) vs Frequency (MHz)</p> <p>AVG_54</p> <p>Site : 03CH074Y Condition : AVG_54 3m HF-ANT_130829 VERTICAL RBW: 1000.000kHz VBW: 1.000kHz SWT: Auto Detector : Peak Project : 671336-01 Mode : 15 : 12</p>

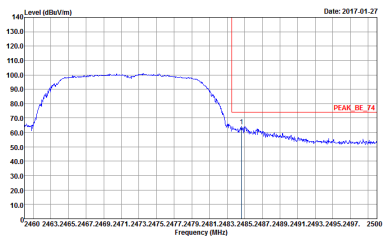
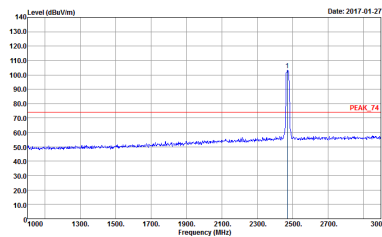
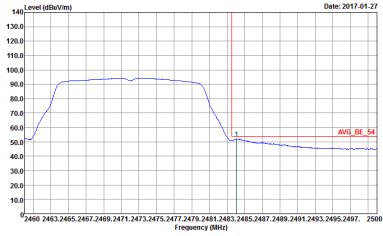
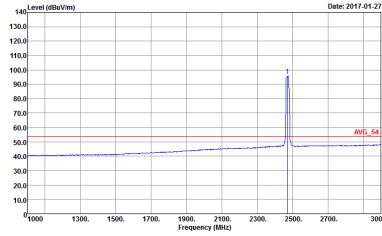

WIFI	2.4GHz 2400~2483.5MHz Band Edge @ 3m	
ANT	802.11g CH13 2472MHz	
1	Horizontal	Fundamental
Peak	 <p>Date: 2017-01-27</p> <p>Level (dBm/100MHz)</p> <p>Frequency (MHz)</p> <p>PEAK_BE_74</p> <p>Site : 03CH07-1Y Condition : PEAK_BE_74 3m HF-ANT_130829 HORIZONTAL RBW: 1000.000kHz VBW: 3000.000kHz SWT: Auto Detector : Peak Project : 671336-01 Mode : 16</p>	 <p>Date: 2017-01-27</p> <p>Level (dBm/100MHz)</p> <p>Frequency (MHz)</p> <p>PEAK_74</p> <p>Site : 03CH07-1Y Condition : PEAK_74 3m HF-ANT_130829 HORIZONTAL RBW: 1000.000kHz VBW: 3000.000kHz SWT: Auto Detector : Peak Project : 671336-01 Mode : 16</p>
Avg.	 <p>Date: 2017-01-27</p> <p>Level (dBm/100MHz)</p> <p>Frequency (MHz)</p> <p>AVG_BE_54</p> <p>Site : 03CH07-1Y Condition : AVG_BE_54 3m HF-ANT_130829 HORIZONTAL RBW: 1000.000kHz VBW: 1.000kHz SWT: Auto Detector : Peak Project : 671336-01 Mode : 16</p>	 <p>Date: 2017-01-27</p> <p>Level (dBm/100MHz)</p> <p>Frequency (MHz)</p> <p>AVG_54</p> <p>Site : 03CH07-1Y Condition : AVG_54 3m HF-ANT_130829 HORIZONTAL RBW: 1000.000kHz VBW: 1.000kHz SWT: Auto Detector : Peak Project : 671336-01 Mode : 16</p>

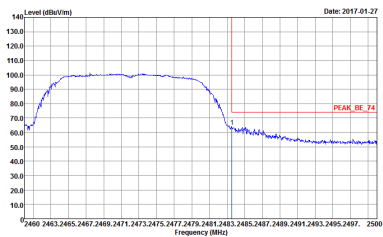
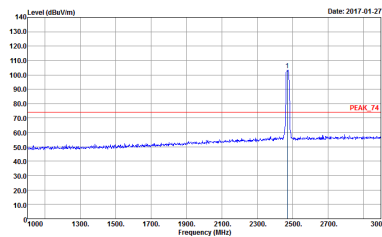
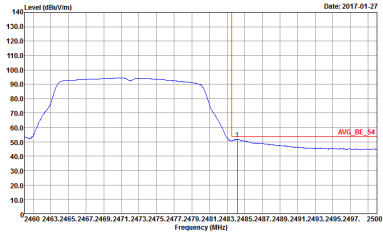
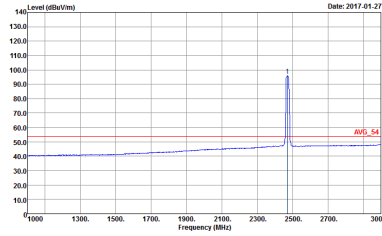

WIFI	2.4GHz 2400~2483.5MHz Band Edge @ 3m	
ANT	802.11g CH13 2472MHz	
1	Vertical	Fundamental
Peak	 <p>Date: 2017-01-27</p> <p>Site : 03CH074Y Condition : PEAK_BE_74 3m HF-ANT_130829 VERTICAL RBW: 1000.000kHz VBW: 3000.000kHz SWT: Auto Detector : Peak Project : 671336-01 Mode : 16</p>	 <p>Date: 2017-01-27</p> <p>Site : 03CH074Y Condition : PEAK_74 3m HF-ANT_130829 VERTICAL RBW: 1000.000kHz VBW: 3000.000kHz SWT: Auto Detector : Peak Project : 671336-01 Mode : 16</p>
Avg.	 <p>Date: 2017-01-27</p> <p>Site : 03CH074Y Condition : AVG_BE_54 3m HF-ANT_130829 VERTICAL RBW: 1000.000kHz VBW: 1.000kHz SWT: Auto Detector : Peak Project : 671336-01 Mode : 16</p>	 <p>Date: 2017-01-27</p> <p>Site : 03CH074Y Condition : AVG_54 3m HF-ANT_130829 VERTICAL RBW: 1000.000kHz VBW: 1.000kHz SWT: Auto Detector : Peak Project : 671336-01 Mode : 16</p>



2.4GHz 2400~2483.5MHz

WIFI 802.11n HT20 (Band Edge @ 3m)

WIFI	2.4GHz 2400~2483.5MHz Band Edge @ 3m	
ANT	802.11n HT20 CH01 2412MHz	
1	Horizontal	Fundamental
Peak	<p>Site : 03CH07-FY Condition : PEAK_BE_74 3m HF-ANT_130829 HORIZONTAL REW:1000 000kHz VBW:3000 000kHz SWT:Auto Detector : Peak Project : 671336-01 Mode : 17</p>	<p>Site : 03CH07-FY Condition : PEAK_74 3m HF-ANT_130829 HORIZONTAL REW:1000 000kHz VBW:3000 000kHz SWT:Auto Detector : Peak Project : 671336-01 Mode : 17</p>
Avg.	<p>Site : 03CH07-FY Condition : AVG_BE_74 3m HF-ANT_130829 HORIZONTAL REW:1000 000kHz VBW:1.000kHz SWT:Auto Detector : Peak Project : 671336-01 Mode : 17</p>	<p>Site : 03CH07-FY Condition : AVG_54 3m HF-ANT_130829 HORIZONTAL REW:1000 000kHz VBW:1.000kHz SWT:Auto Detector : Peak Project : 671336-01 Mode : 17</p>

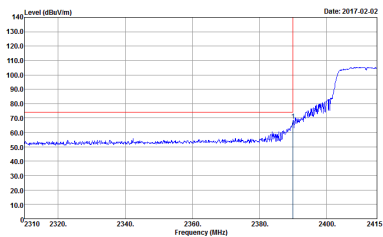
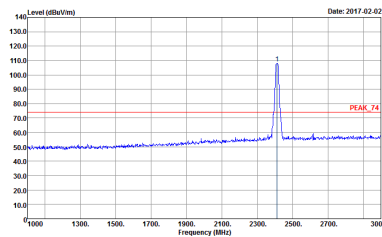
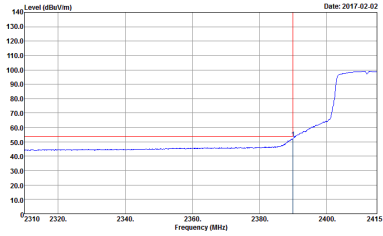
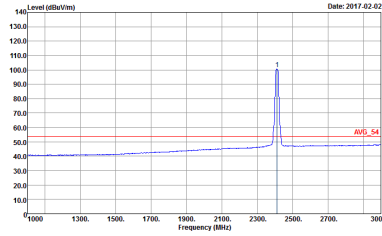

WIFI	2.4GHz 2400~2483.5MHz Band Edge @ 3m	
ANT	802.11n HT20 CH01 2412MHz	
1	Vertical	Fundamental
Peak	 <p>Date: 2017.02.02</p> <p>Site : 03CH074Y Condition : PEAK_BE_74 3m HF-ANT_130829 VERTICAL RBW:1000.000kHz VBW:3000.000kHz SWT:Auto Detector : Peak Project : 671336-01 Mode : 17 : 13</p>	 <p>Date: 2017.02.02</p> <p>Site : 03CH074Y Condition : PEAK_74 3m HF-ANT_130829 VERTICAL RBW:1000.000kHz VBW:3000.000kHz SWT:Auto Detector : Peak Project : 671336-01 Mode : 17 : 13</p>
Avg.	 <p>Date: 2017.02.02</p> <p>Site : 03CH074Y Condition : AVG_BE_54 3m HF-ANT_130829 VERTICAL RBW:1000.000kHz VBW:1.000kHz SWT:Auto Detector : Peak Project : 671336-01 Mode : 17 : 13</p>	 <p>Date: 2017.02.02</p> <p>Site : 03CH074Y Condition : AVG_54 3m HF-ANT_130829 VERTICAL RBW:1000.000kHz VBW:1.000kHz SWT:Auto Detector : Peak Project : 671336-01 Mode : 17 : 13</p>

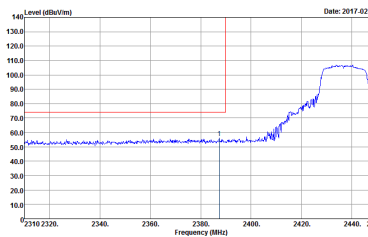
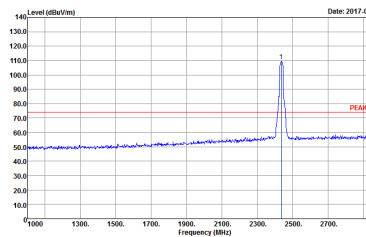
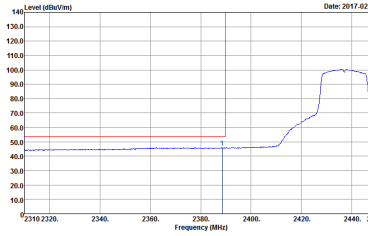
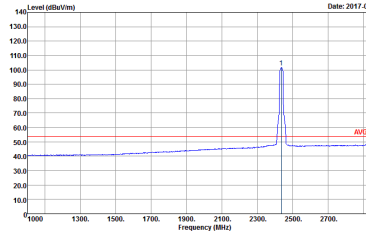

WIFI	2.4GHz 2400~2483.5MHz Band Edge @ 3m	
ANT	802.11n HT20 CH06 2437MHz - L	
1	Horizontal	Fundamental
Peak	 <p>Date: 2017.02.02</p> <p>Site : 03CH07-4Y Condition : PEAK_BE_74 3m HF-ANT_130829 HORIZONTAL RBW:1000.000kHz VBW:3000.000kHz SWT:Auto Detector : Peak Project : 671336-01 Mode : 18</p>	 <p>Date: 2017.02.02</p> <p>Site : 03CH07-4Y Condition : PEAK_74 3m HF-ANT_130829 HORIZONTAL RBW:1000.000kHz VBW:3000.000kHz SWT:Auto Detector : Peak Project : 671336-01 Mode : 18</p>
Avg.	 <p>Date: 2017.02.02</p> <p>Site : 03CH07-4Y Condition : AVG_BE_54 3m HF-ANT_130829 HORIZONTAL RBW:1000.000kHz VBW:1.000kHz SWT:Auto Detector : Peak Project : 671336-01 Mode : 18</p>	 <p>Date: 2017.02.02</p> <p>Site : 03CH07-4Y Condition : AVG_54 3m HF-ANT_130829 HORIZONTAL RBW:1000.000kHz VBW:1.000kHz SWT:Auto Detector : Peak Project : 671336-01 Mode : 18</p>

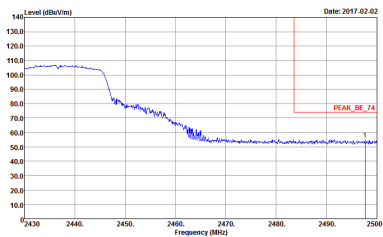
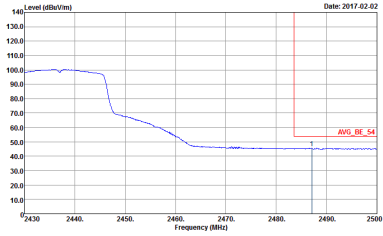

WIFI	2.4GHz 2400~2483.5MHz Band Edge @ 3m	
ANT	802.11n HT20 CH06 2437MHz - R	
1	Horizontal	Fundamental
<p>Peak</p>	 <p>Date: 2017.02.02</p> <p>Site : 03CH074Y Condition : PEAK_BE_74 3m HF-ANT_130829 HORIZONTAL Detector : Peak Project : 671336-01 Mode : 18</p>	<p>Left blank</p>
<p>Avg.</p>	 <p>Date: 2017.02.02</p> <p>Site : 03CH074Y Condition : AVG_BE_54 3m HF-ANT_130829 HORIZONTAL Detector : Peak Project : 671336-01 Mode : 18</p>	<p>Left blank</p>

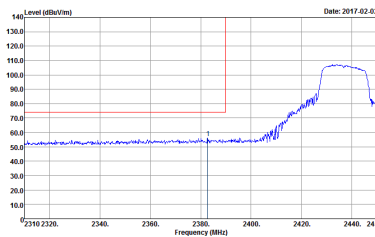
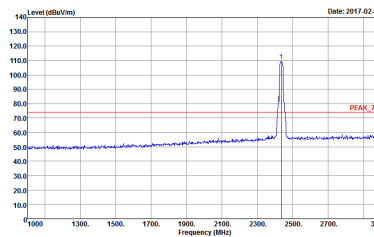
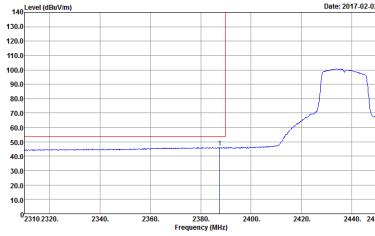
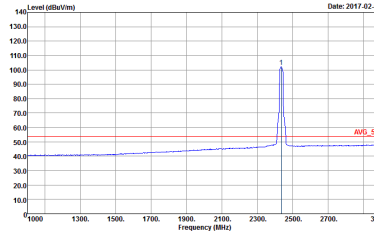

WIFI	2.4GHz 2400~2483.5MHz Band Edge @ 3m	
ANT	802.11n HT20 CH06 2437MHz - L	
1	Vertical	Fundamental
Peak	 <p>Date: 2017.02.02</p> <p>Site : 03CH074Y Condition : PEAK_BE_74 3m HF-ANT_130829 VERTICAL RBW:1000.000kHz VBW:3000.000kHz SWT:Auto Detector : Peak Project : 671336-01 Mode : 18</p>	 <p>Date: 2017.02.02</p> <p>Site : 03CH074Y Condition : PEAK_74 3m HF-ANT_130829 VERTICAL RBW:1000.000kHz VBW:3000.000kHz SWT:Auto Detector : Peak Project : 671336-01 Mode : 18</p>
Avg.	 <p>Date: 2017.02.02</p> <p>Site : 03CH074Y Condition : AVG_BE_54 3m HF-ANT_130829 VERTICAL RBW:1000.000kHz VBW:1.000kHz SWT:Auto Detector : Peak Project : 671336-01 Mode : 18</p>	 <p>Date: 2017.02.02</p> <p>Site : 03CH074Y Condition : AVG_54 3m HF-ANT_130829 VERTICAL RBW:1000.000kHz VBW:1.000kHz SWT:Auto Detector : Peak Project : 671336-01 Mode : 18</p>

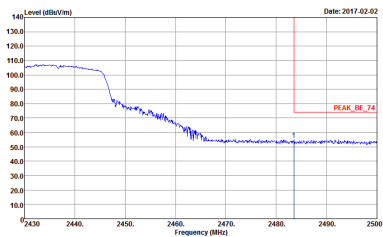
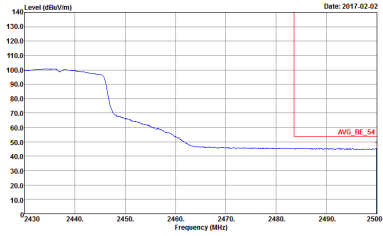

WIFI	2.4GHz 2400~2483.5MHz Band Edge @ 3m	
ANT	802.11n HT20 CH06 2437MHz - R	
1	Vertical	Fundamental
<p>Peak</p>	 <p>Date: 2017.02.02</p> <p>Site : 03CH074Y Condition : PEAK_BE_74 3m HF-ANT_130829 VERTICAL Detector : Peak Project : 671336-01 Mode : 18</p>	<p>Left Blank</p>
<p>Avg.</p>	 <p>Date: 2017.02.02</p> <p>Site : 03CH074Y Condition : AVG_BE_54 3m HF-ANT_130829 VERTICAL Detector : Peak Project : 671336-01 Mode : 18</p>	<p>Left Blank</p>

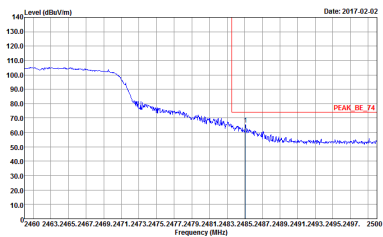
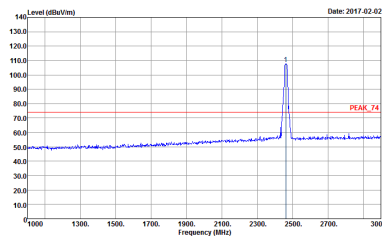
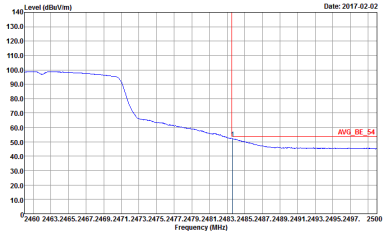
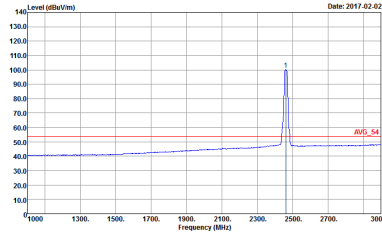

WIFI	2.4GHz 2400~2483.5MHz Band Edge @ 3m	
ANT	802.11n HT20 CH11 2462MHz	
1	Horizontal	Fundamental
Peak	 <p>Level (dBm/100MHz) vs Frequency (MHz) plot for Horizontal polarization. The plot shows a signal level starting at approximately 100 dBm/100MHz at 2400 MHz and decreasing to about 50 dBm/100MHz at 2483.5 MHz. A red vertical line marks the peak at 2462 MHz, labeled 'PEAK_BE_74'.</p> <p>Site : 03CH074Y Condition : PEAK_BE_74 3m HF-ANT_130829 HORIZONTAL Detector : Peak Project : 671336-01 Mode : 19</p>	 <p>Level (dBm/100MHz) vs Frequency (MHz) plot for Fundamental polarization. The plot shows a sharp peak at 2462 MHz with a level of approximately 110 dBm/100MHz. A red vertical line marks the peak, labeled 'PEAK_74'.</p> <p>Site : 03CH074Y Condition : PEAK_74 3m HF-ANT_130829 HORIZONTAL Detector : Peak Project : 671336-01 Mode : 19</p>
Avg.	 <p>Level (dBm/100MHz) vs Frequency (MHz) plot for Horizontal polarization. The plot shows the average signal level, which is smoother than the peak plot. A red vertical line marks the average level at 2462 MHz, labeled 'AVG_BE_54'.</p> <p>Site : 03CH074Y Condition : AVG_BE_54 3m HF-ANT_130829 HORIZONTAL Detector : Peak Project : 671336-01 Mode : 19</p>	 <p>Level (dBm/100MHz) vs Frequency (MHz) plot for Fundamental polarization. The plot shows the average signal level, with a sharp peak at 2462 MHz. A red vertical line marks the average level, labeled 'AVG_54'.</p> <p>Site : 03CH074Y Condition : AVG_54 3m HF-ANT_130829 HORIZONTAL Detector : Peak Project : 671336-01 Mode : 19</p>

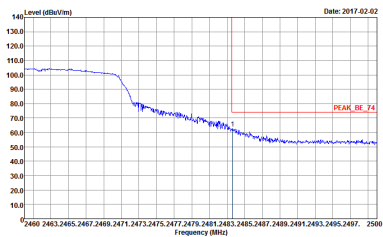
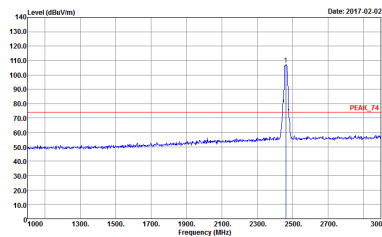
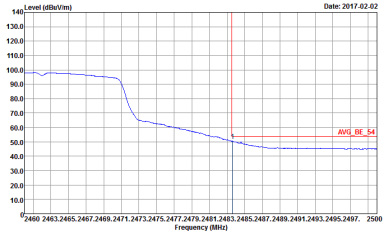
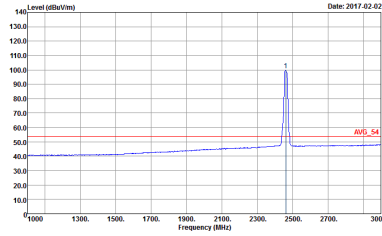

WIFI	2.4GHz 2400~2483.5MHz Fundamental @ 3m	
ANT	802.11n HT20 CH11 2462MHz	
1	Vertical	Fundamental
Peak	 <p>Date: 2017.02.02</p> <p>Site : 03CH074Y Condition : PEAK_BE_74 3m HF-ANT_130829 VERTICAL RBW: 1000.000kHz VBW: 3000.000kHz SWT: Auto Detector : Peak Project : 671336-01 Mode : 19</p>	 <p>Date: 2017.02.02</p> <p>Site : 03CH074Y Condition : PEAK_74 3m HF-ANT_130829 VERTICAL RBW: 1000.000kHz VBW: 3000.000kHz SWT: Auto Detector : Peak Project : 671336-01 Mode : 19</p>
Avg.	 <p>Date: 2017.02.02</p> <p>Site : 03CH074Y Condition : AVG_BE_54 3m HF-ANT_130829 VERTICAL RBW: 1000.000kHz VBW: 1.000kHz SWT: Auto Detector : Peak Project : 671336-01 Mode : 19</p>	 <p>Date: 2017.02.02</p> <p>Site : 03CH074Y Condition : AVG_54 3m HF-ANT_130829 VERTICAL RBW: 1000.000kHz VBW: 1.000kHz SWT: Auto Detector : Peak Project : 671336-01 Mode : 19</p>

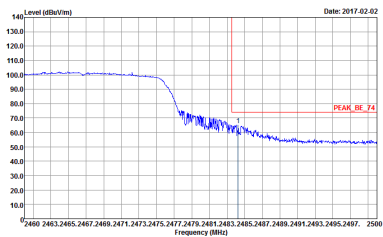
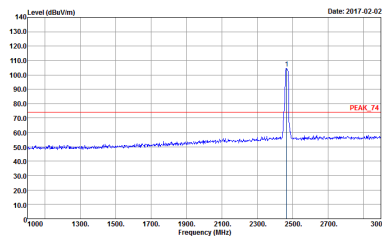
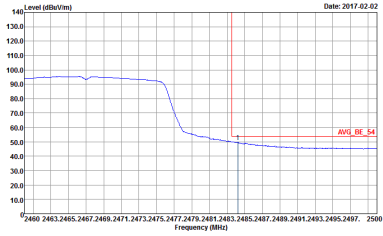
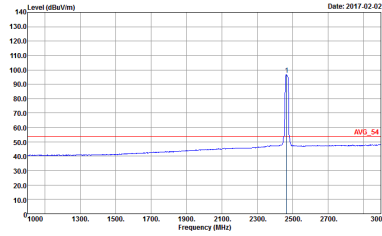

WIFI	2.4GHz 2400~2483.5MHz Band Edge @ 3m	
ANT	802.11n HT20 CH12 2467MHz	
1	Horizontal	Fundamental
Peak	 <p>Level (dBm/1m) vs Frequency (MHz) plot for Horizontal polarization. The plot shows a signal level around 100 dBm/1m from 2400 MHz to 2467 MHz, which then drops to approximately 50 dBm/1m. A red vertical line marks the peak at 2467 MHz, labeled 'PEAK_BE_74'.</p> <p>Site : 03CH074Y Condition : PEAK_BE_74 3m HF-ANT_130829 HORIZONTAL RBW: 1000.000kHz VBW: 3000.000kHz SWT: Auto Detector : Peak Project : 671336-01 Mode : 20 : 11</p>	 <p>Level (dBm/1m) vs Frequency (MHz) plot for Fundamental polarization. The plot shows a flat noise floor around 50 dBm/1m with a sharp peak at 2467 MHz, labeled 'PEAK_74'.</p> <p>Site : 03CH074Y Condition : PEAK_74 3m HF-ANT_130829 HORIZONTAL RBW: 1000.000kHz VBW: 3000.000kHz SWT: Auto Detector : Peak Project : 671336-01 Mode : 20 : 11</p>
Avg.	 <p>Level (dBm/1m) vs Frequency (MHz) plot for Horizontal polarization. The plot shows a signal level around 100 dBm/1m from 2400 MHz to 2467 MHz, which then drops to approximately 50 dBm/1m. A red vertical line marks the average level at 2467 MHz, labeled 'AVG_BE_54'.</p> <p>Site : 03CH074Y Condition : AVG_BE_54 3m HF-ANT_130829 HORIZONTAL RBW: 1000.000kHz VBW: 1.000kHz SWT: Auto Detector : Peak Project : 671336-01 Mode : 20 : 11</p>	 <p>Level (dBm/1m) vs Frequency (MHz) plot for Fundamental polarization. The plot shows a flat noise floor around 50 dBm/1m with a sharp peak at 2467 MHz, labeled 'AVG_54'.</p> <p>Site : 03CH074Y Condition : AVG_54 3m HF-ANT_130829 HORIZONTAL RBW: 1000.000kHz VBW: 1.000kHz SWT: Auto Detector : Peak Project : 671336-01 Mode : 20 : 11</p>

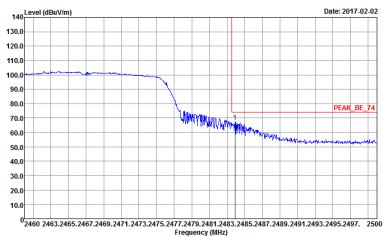
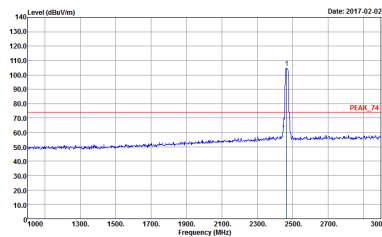
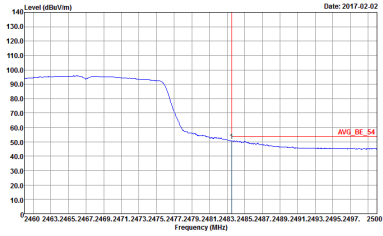
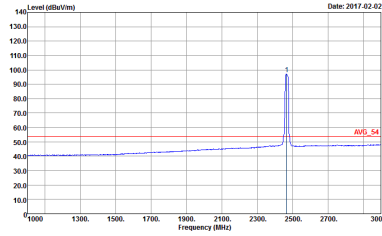

WIFI	2.4GHz 2400~2483.5MHz Band Edge @ 3m	
ANT	802.11n HT20 CH12 2467MHz	
1	Vertical	Fundamental
Peak	 <p>Date: 2017.02.02</p> <p>Site : 03CH074Y Condition : PEAK_BE_74 3m HF-ANT_130829 VERTICAL RBW: 1000.000kHz VBW: 3000.000kHz SWT: Auto Detector : Peak Project : 671336-01 Mode : 20 : 11</p>	 <p>Date: 2017.02.02</p> <p>Site : 03CH074Y Condition : PEAK_74 3m HF-ANT_130829 VERTICAL RBW: 1000.000kHz VBW: 3000.000kHz SWT: Auto Detector : Peak Project : 671336-01 Mode : 20 : 11</p>
Avg.	 <p>Date: 2017.02.02</p> <p>Site : 03CH074Y Condition : AVG_BE_54 3m HF-ANT_130829 VERTICAL RBW: 1000.000kHz VBW: 1.000kHz SWT: Auto Detector : Peak Project : 671336-01 Mode : 20 : 11</p>	 <p>Date: 2017.02.02</p> <p>Site : 03CH074Y Condition : AVG_54 3m HF-ANT_130829 VERTICAL RBW: 1000.000kHz VBW: 1.000kHz SWT: Auto Detector : Peak Project : 671336-01 Mode : 20 : 11</p>

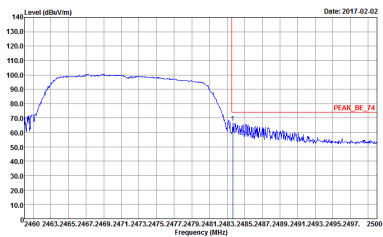
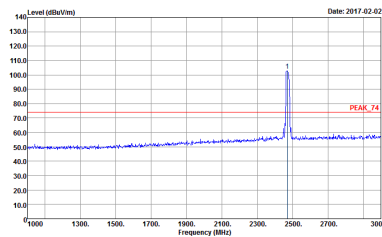
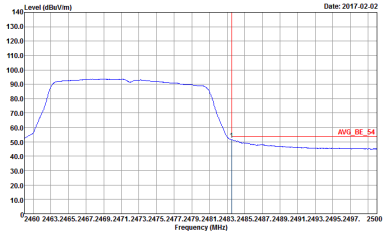
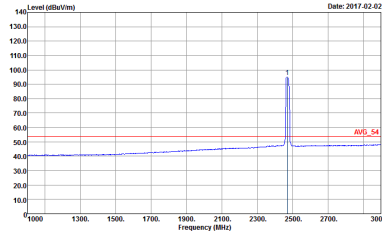

WIFI	2.4GHz 2400~2483.5MHz Band Edge @ 3m	
ANT	802.11n HT20 CH13 2472MHz	
1	Horizontal	Fundamental
Peak	 <p>Level (dBm/100MHz) vs Frequency (MHz) plot for Peak Horizontal. The plot shows a signal level around 90 dBm/100MHz from 2400 to 2472 MHz, then dropping to approximately 50 dBm/100MHz. A red vertical line marks the peak at 2472 MHz, labeled 'PEAK_BE_74'.</p> <p>Site : 03CH074Y Condition : PEAK_BE_74 3m HF-ANT_130829 HORIZONTAL RBW: 1000.000kHz VBW: 3000.000kHz SWT: Auto Detector : Peak Project : 671336-01 Mode : -21 -9</p>	 <p>Level (dBm/100MHz) vs Frequency (MHz) plot for Peak Fundamental. The plot shows a flat noise floor around 50 dBm/100MHz with a sharp peak at 2472 MHz reaching approximately 100 dBm/100MHz. A red vertical line marks the peak, labeled 'PEAK_74'.</p> <p>Site : 03CH074Y Condition : PEAK_74 3m HF-ANT_130829 HORIZONTAL RBW: 1000.000kHz VBW: 3000.000kHz SWT: Auto Detector : Peak Project : 671336-01 Mode : -21 -9</p>
Avg.	 <p>Level (dBm/100MHz) vs Frequency (MHz) plot for Avg Horizontal. The plot shows a signal level around 90 dBm/100MHz from 2400 to 2472 MHz, then dropping to approximately 50 dBm/100MHz. A red vertical line marks the average level at 2472 MHz, labeled 'AVG_BE_54'.</p> <p>Site : 03CH074Y Condition : AVG_BE_54 3m HF-ANT_130829 HORIZONTAL RBW: 1000.000kHz VBW: 1.000kHz SWT: Auto Detector : Peak Project : 671336-01 Mode : -21 -9</p>	 <p>Level (dBm/100MHz) vs Frequency (MHz) plot for Avg Fundamental. The plot shows a flat noise floor around 50 dBm/100MHz with a sharp peak at 2472 MHz reaching approximately 100 dBm/100MHz. A red vertical line marks the average level, labeled 'AVG_54'.</p> <p>Site : 03CH074Y Condition : AVG_54 3m HF-ANT_130829 HORIZONTAL RBW: 1000.000kHz VBW: 1.000kHz SWT: Auto Detector : Peak Project : 671336-01 Mode : -21 -9</p>

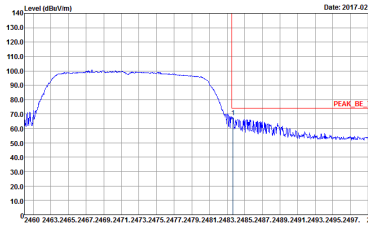
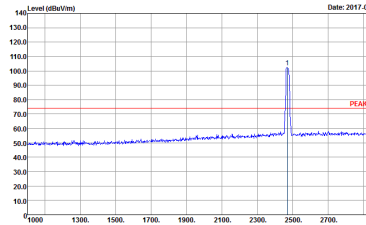
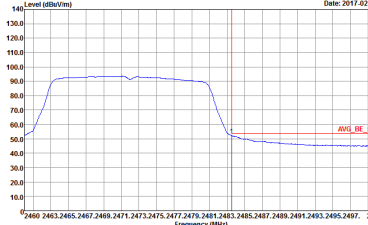
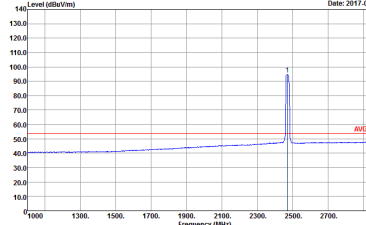

WIFI	2.4GHz 2400~2483.5MHz Band Edge @ 3m	
ANT	802.11n HT20 CH13 2472MHz	
1	Vertical	Fundamental
Peak	 <p>Site : 03CH074Y Condition : PEAK_BE_74 3m HF-ANT_130829 VERTICAL Detector : Peak Project : 671336-01 Mode : 9</p>	 <p>Site : 03CH074Y Condition : PEAK_74 3m HF-ANT_130829 VERTICAL Detector : Peak Project : 671336-01 Mode : 9</p>
Avg.	 <p>Site : 03CH074Y Condition : AVG_BE_54 3m HF-ANT_130829 VERTICAL Detector : Peak Project : 671336-01 Mode : 9</p>	 <p>Site : 03CH074Y Condition : AVG_54 3m HF-ANT_130829 VERTICAL Detector : Peak Project : 671336-01 Mode : 9</p>



2.4GHz 2400~2483.5MHz

WIFI 802.11b (Harmonic @ 3m)

WIFI	2.4GHz 2400~2483.5MHz Harmonic @ 3m	
ANT	802.11b CH01 2412MHz	
1	Horizontal	Vertical
Peak Avg.		

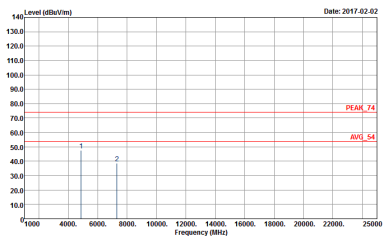
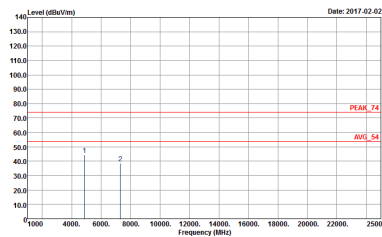

WIFI	2.4GHz 2400~2483.5MHz Harmonic @ 3m	
ANT	802.11b CH06 2437MHz	
1	Horizontal	Vertical
<p>Peak</p> <p>Avg.</p>	 <p>Site : 03CH67-4Y Condition : PEAK_74 3m SHF-EHF_131029 HORIZONTAL Detector : Peak Project : 671336-01 Mode : 8</p>	 <p>Site : 03CH67-4Y Condition : PEAK_74 3m SHF-EHF_131029 VERTICAL Detector : Peak Project : 671336-01 Mode : 8</p>

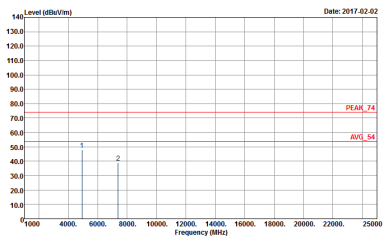
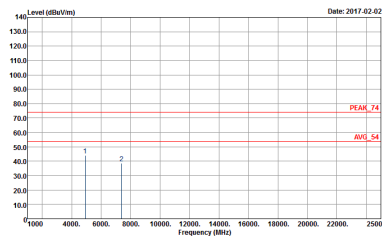

WIFI	2.4GHz 2400~2483.5MHz Harmonic @ 3m	
ANT	802.11b CH11 2462MHz	
1	Horizontal	Vertical
<p>Peak</p> <p>Avg.</p>	 <p>Site : 03C4674Y Condition : PEAK_74 3m SHF-EHF_131029 HORIZONTAL Detector : Peak Project : 671336-01 Mode : 9</p>	 <p>Site : 03C4674Y Condition : PEAK_74 3m SHF-EHF_131029 VERTICAL Detector : Peak Project : 671336-01 Mode : 9</p>



WIFI	2.4GHz 2400~2483.5MHz Harmonic @ 3m	
ANT	802.11b CH12 2467MHz	
1	Horizontal	Vertical
<p>Peak</p> <p>Avg.</p>		



WIFI	2.4GHz 2400~2483.5MHz Harmonic @ 3m	
ANT	802.11b CH13 2472MHz	
1	Horizontal	Vertical
<p>Peak</p> <p>Avg.</p>		



2.4GHz 2400~2483.5MHz

WIFI 802.11g (Harmonic @ 3m)

WIFI	2.4GHz 2400~2483.5MHz Harmonic @ 3m	
ANT	802.11g CH01 2412MHz	
1	Horizontal	Vertical
<p>Peak</p> <p>Avg.</p>		

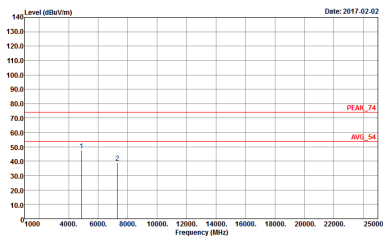
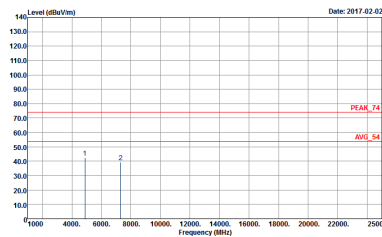

WIFI	2.4GHz 2400~2483.5MHz Harmonic @ 3m	
ANT	802.11g CH06 2437MHz	
1	Horizontal	Vertical
<p>Peak</p> <p>Avg.</p>	 <p>Site : 03CH67-4Y Condition : PEAK_74 3m SHF-EHF_131029 HORIZONTAL Detector : Peak Project : 671336-01 Mode : 13</p>	 <p>Site : 03CH67-4Y Condition : PEAK_74 3m SHF-EHF_131029 VERTICAL Detector : Peak Project : 671336-01 Mode : 13</p>

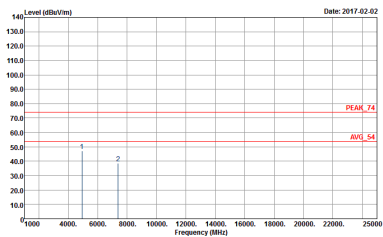
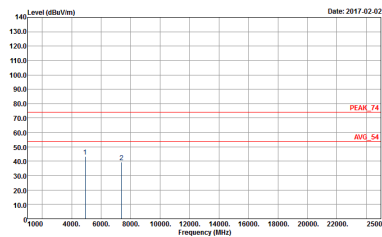

WIFI	2.4GHz 2400~2483.5MHz Harmonic @ 3m	
ANT	802.11g CH11 2462MHz	
1	Horizontal	Vertical
<p>Peak</p> <p>Avg.</p>	 <p>Site : 03CH67-41Y Condition : PEAK_74 3m SHF-EHF_131029 HORIZONTAL Detector : Peak Project : 671336-01 Mode : 14</p>	 <p>Site : 03CH67-41Y Condition : PEAK_74 3m SHF-EHF_131029 VERTICAL Detector : Peak Project : 671336-01 Mode : 14</p>

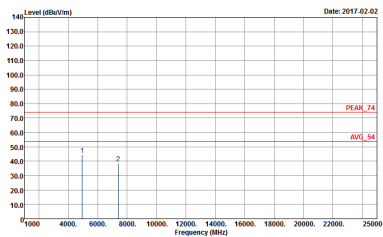
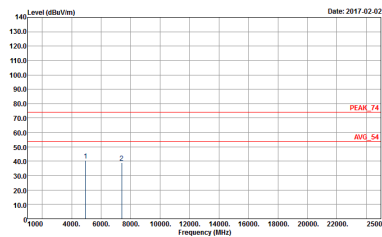

WIFI	2.4GHz 2400~2483.5MHz Harmonic @ 3m	
ANT	802.11g CH12 2467MHz	
1	Horizontal	Vertical
<p>Peak</p> <p>Avg.</p>	 <p>Site : 03CH67-4Y Condition : PEAK_74 3m SHF-EHF_131029 HORIZONTAL Detector : Peak Project : FR1336-01 Mode : 15 : 12</p>	 <p>Site : 03CH67-4Y Condition : PEAK_74 3m SHF-EHF_131029 VERTICAL Detector : Peak Project : FR1336-01 Mode : 15 : 12</p>



WIFI	2.4GHz 2400~2483.5MHz Harmonic @ 3m	
ANT	802.11g CH13 2472MHz	
1	Horizontal	Vertical
<p>Peak</p> <p>Avg.</p>	<p>Site : 03CH674Y Condition : PEAK_74 3m SHF-EHF_131029 HORIZONTAL Detector : Peak Project : 671336-01 Mode : 16</p>	<p>Site : 03CH674Y Condition : PEAK_74 3m SHF-EHF_131029 VERTICAL Detector : Peak Project : 671336-01 Mode : 16</p>



2.4GHz 2400~2483.5MHz

WIFI 802.11n HT20 (Harmonic @ 3m)

WIFI	2.4GHz 2400~2483.5MHz Harmonic @ 3m	
ANT	802.11n HT20 CH01 2412MHz	
1	Horizontal	Vertical
<p>Peak</p> <p>Avg.</p>	<p>Site : 03C3M7-4Y Condition : PEAK_74 3m SHF-EHF_131029 HORIZONTAL Detector : Peak Project : 671336-01 Mode : 17</p>	<p>Site : 03C3M7-4Y Condition : PEAK_74 3m SHF-EHF_131029 VERTICAL Detector : Peak Project : 671336-01 Mode : 17</p>



WIFI	2.4GHz 2400~2483.5MHz Harmonic @ 3m	
ANT	802.11n HT20 CH06 2437MHz	
1	Horizontal	Vertical
<p>Peak</p> <p>Avg.</p>	<p>Site : 03CH67-4Y Condition : PEAK_74 3m SHF-EHF_131029 HORIZONTAL Detector : Peak Project : 671336-01 Mode : 18</p>	<p>Site : 03CH67-4Y Condition : PEAK_74 3m SHF-EHF_131029 VERTICAL Detector : Peak Project : 671336-01 Mode : 18</p>

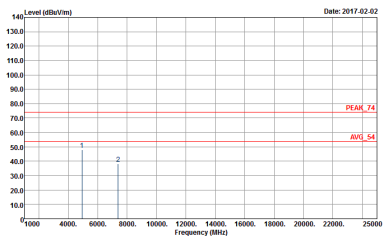
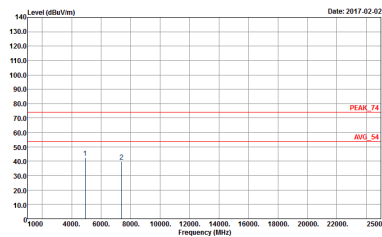

WIFI	2.4GHz 2400~2483.5MHz Harmonic @ 3m	
ANT	802.11n HT20 CH11 2462MHz	
1	Horizontal	Vertical
<p>Peak</p> <p>Avg.</p>	 <p>Site : 03CH67-4Y Condition : PEAK_74 3m SHF-EHF_131029 HORIZONTAL Detector : Peak Project : 671336-01 Mode : 19</p>	 <p>Site : 03CH67-4Y Condition : PEAK_74 3m SHF-EHF_131029 VERTICAL Detector : Peak Project : 671336-01 Mode : 19</p>

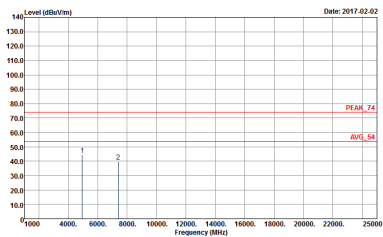
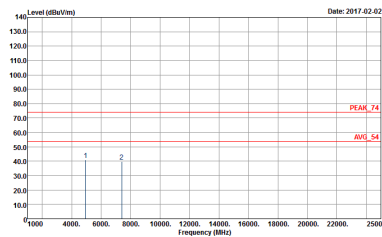

WIFI	2.4GHz 2400~2483.5MHz Harmonic @ 3m	
ANT	802.11n HT20 CH12 2462MHz	
1	Horizontal	Vertical
<p>Peak</p> <p>Avg.</p>	 <p>Site : 03C4674Y Condition : PEAK_74 3m SHF-EHF_131029 HORIZONTAL Detector : Peak Project : 671336-01 Mode : 20 : 11</p>	 <p>Site : 03C4674Y Condition : PEAK_74 3m SHF-EHF_131029 VERTICAL Detector : Peak Project : 671336-01 Mode : 20 : 11</p>



WIFI	2.4GHz 2400~2483.5MHz Harmonic @ 3m	
ANT	802.11n HT20 CH13 2472MHz	
1	Horizontal	Vertical
<p>Peak</p> <p>Avg.</p>		



Emission below 1GHz

2.4GHz WIFI 802.11g (LF)

WIFI	2.4GHz 2400~2483.5MHz	
ANT	802.11g LF	
1	Horizontal	Vertical
QP / Peak	<p>Site : 02CH07-01Y Condition : QP-3m LF-ANT-35419(E) HORIZONTAL Detector : Peak Project : 671336-01 Mode : 24</p>	<p>Site : 02CH07-01Y Condition : QP-3m LF-ANT-35419(E) VERTICAL Detector : Peak Project : 671336-01 Mode : 24</p>



Appendix D. Duty Cycle Plots

Band	Duty Cycle(%)	T(us)	1/T(kHz)	VBW Setting
802.11b	98.59	-	-	10Hz
802.11g	92.72	1400	0.71	1kHz
2.4GHz 802.11n HT20	91.55	0.77	1kHz	

802.11b

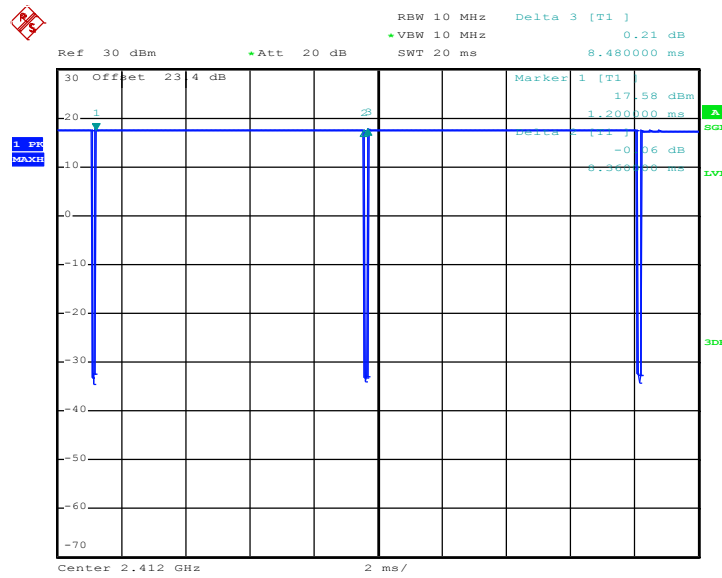

Date: 25.JAN.2017 11:24:14



802.11g

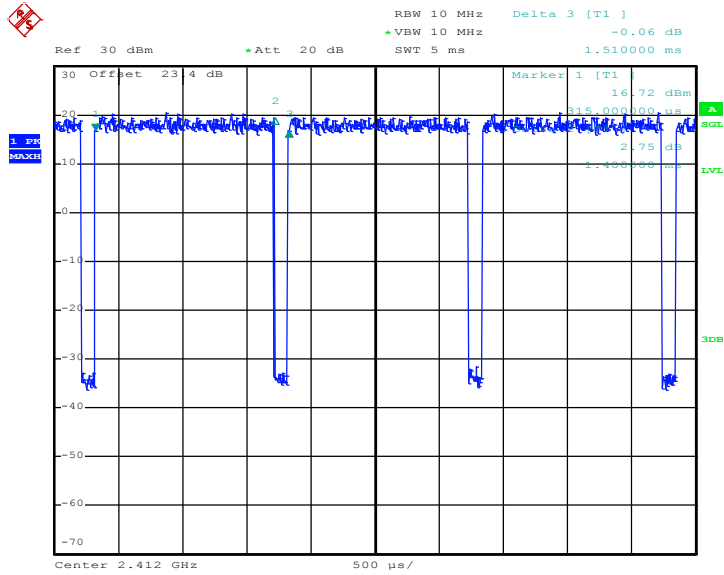

Date: 25.JAN.2017 11:32:51

802.11n HT20

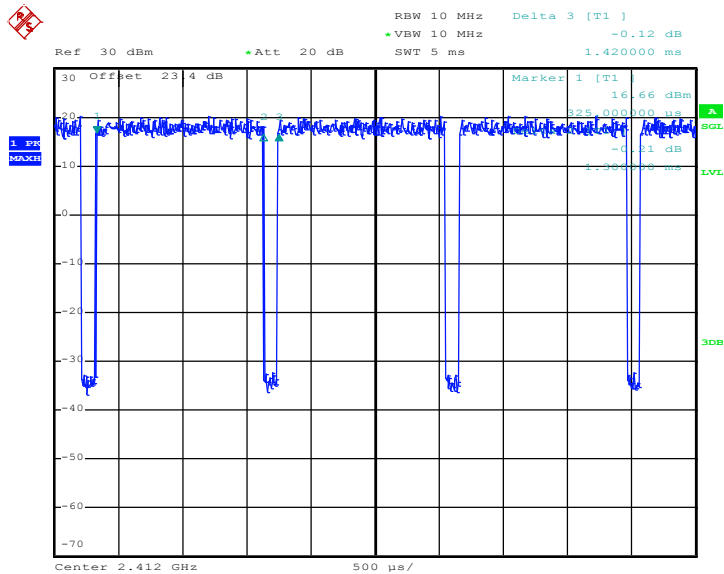

Date: 25.JAN.2017 11:51:32