

Uplink-H	1850-1910
----------	-----------

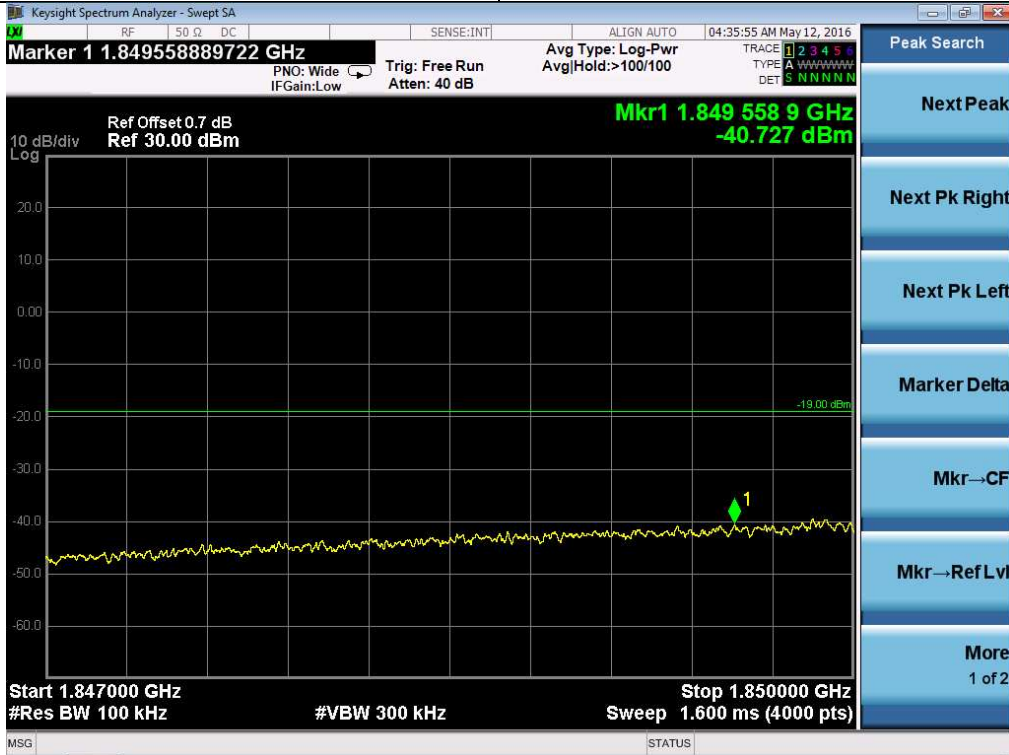

Uplink-L	1850-1910
----------	-----------



Downlink-H	2110-2155
------------	-----------

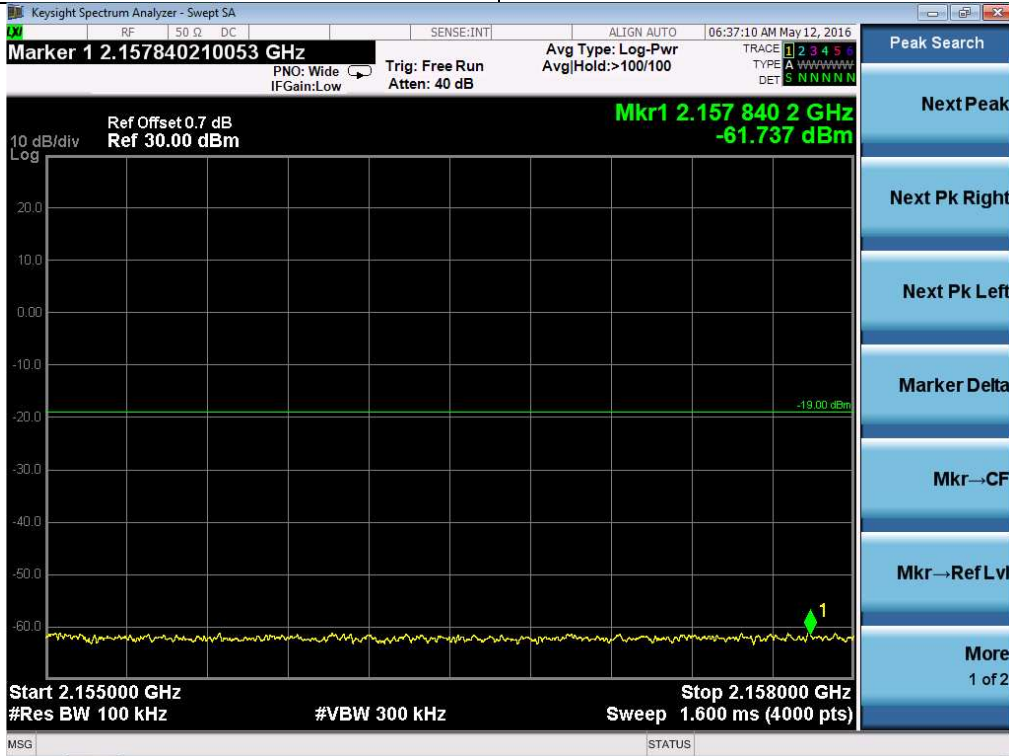

Downlink-L	2110-2155
------------	-----------

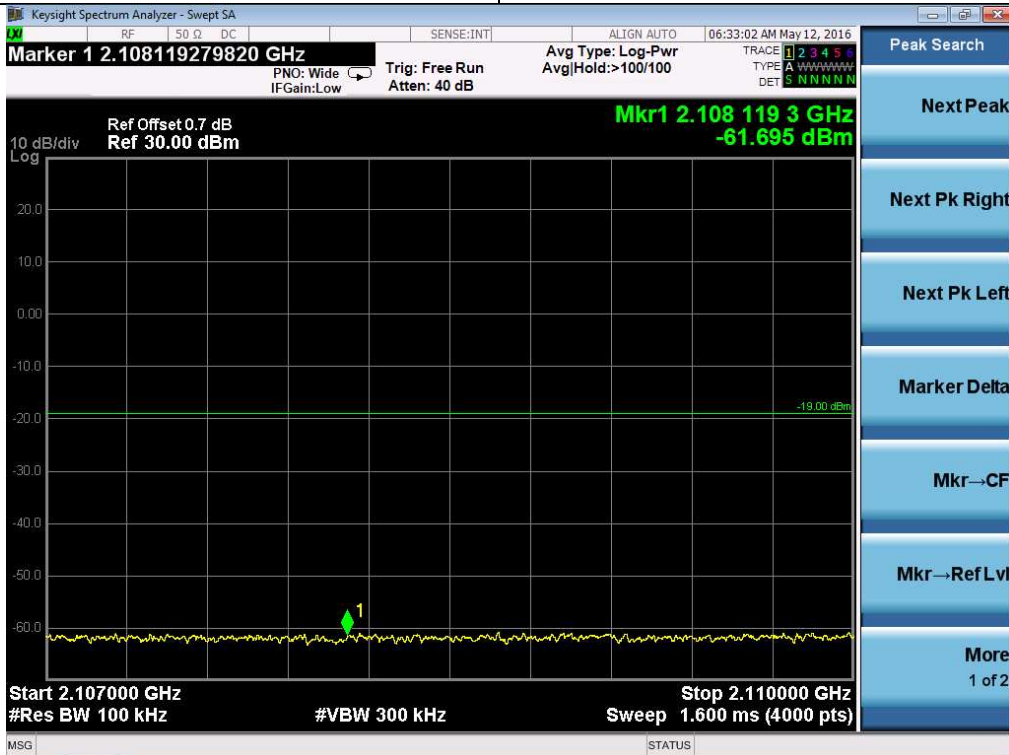

Downlink-H	869-894
------------	---------



Downlink-L	869-894
------------	---------



Downlink-H	746-757
------------	---------



Downlink-L	746-757
------------	---------

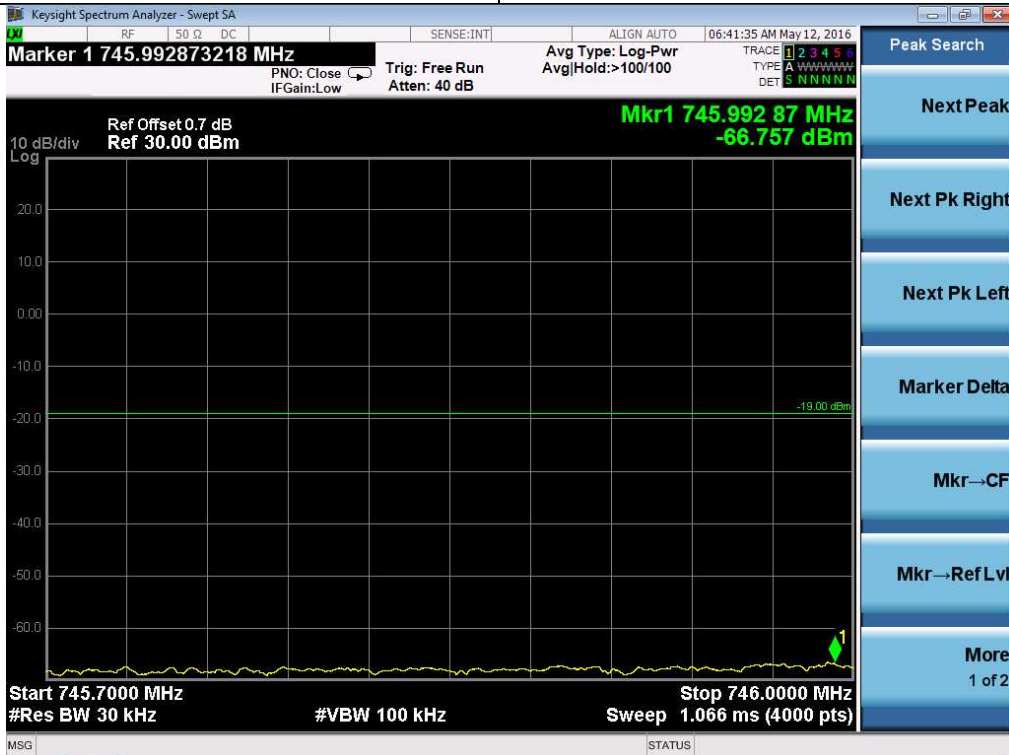

Downlink-H	734-746
------------	---------



Downlink-L	734-746
------------	---------

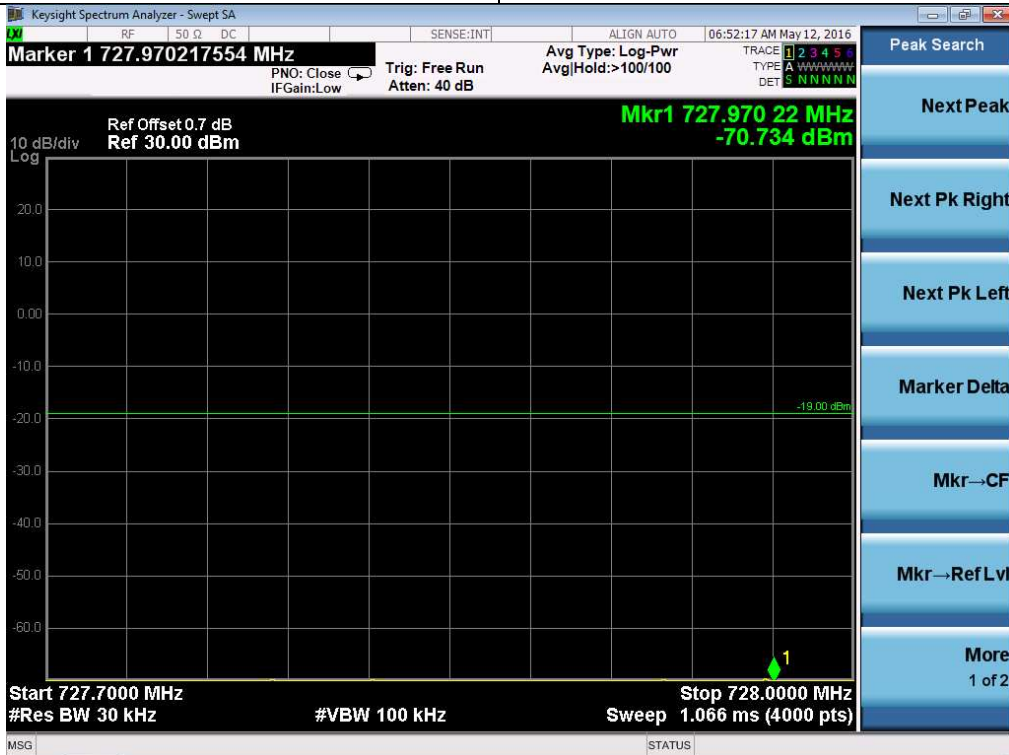

Downlink-H	1930-1990
------------	-----------

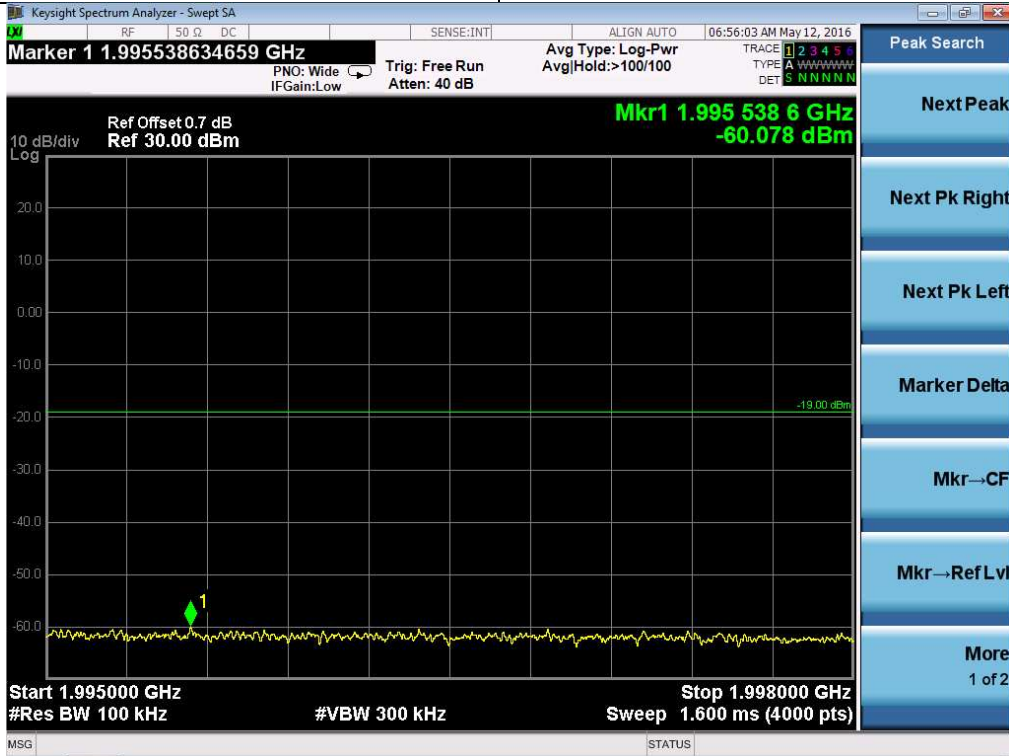

Downlink-L	1930-1990
------------	-----------



8. Conducted spurious emissions

Test result: Pass

8.1 Test limit

Out-of-band Emissions Limit = $P1 - (43 + 10\text{Log}(P2)) = -13\text{dBm}$

P1 = power in dBm

P2 = power in Watts

Special requirements for uplink Band 776-787MHz / downlink Band 746-757MHz:

FCC part 27.53(c): On all frequencies between 763-775 MHz and 793-805 MHz, by a factor not less than $76 + 10 \log (P)$ dB = -46dB in a 6.25 kHz band segment, for base and fixed stations;

FCC part 27.53(e): For operations in the 746-758 MHz, 775-788 MHz, and 805-806 MHz bands, emissions in the band 1559-1610 MHz shall be limited to -40dBm/MHz EIRP for wideband signals, and -50dBm EIRP for discrete emissions of less than 700 Hz bandwidth.

8.2 Test Configuration

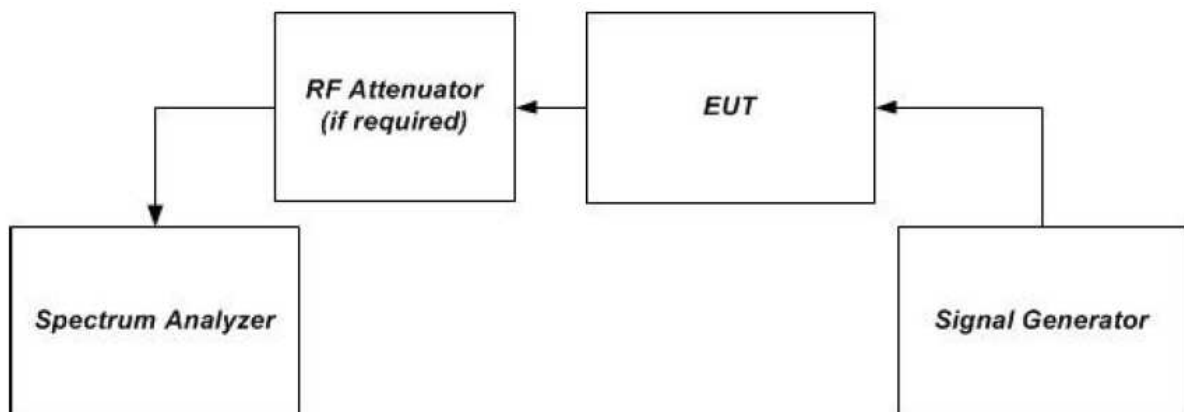

8.3 Test procedure and test setup

- a) Begin with the uplink output (donor) port connected to the spectrum analyzer.
- b) Configure the signal generator for AWGN with a 99% OBW of 4.1 MHz, with a center frequency corresponding to the center of the CMRS band under test.
- c) Set the signal generator amplitude to the level determined in the power measurement procedure.
- d) Turn on the signal generator RF output and measure the spurious emission power levels with an appropriate measuring instrument as follows.
 - 1) Set RBW = measurement bandwidth specified in the applicable rule section for the operational frequency band under consideration (see Appendix A for relevant cross-references). Note that many of the individual rule sections permit the use of a narrower RBW [typically $\geq 1\%$ of the emission bandwidth (EBW)] to enhance measurement accuracy, but the result must then be integrated over the specified measurement bandwidth.
 - 2) Set VBW = $3 \cdot \text{RBW}$.
 - 3) Select the power averaging (rms) detector. (See above note regarding the use of a peak detector for preliminary measurements.)
 - 4) Sweep time = auto-couple.
 - 5) Set the analyzer start frequency to the lowest radio frequency signal generated in the equipment, without going below 9 kHz, and the stop frequency to the lower band/block edge frequency minus 100 kHz or 1 MHz, as specified in the applicable rule part. Note that the number of measurement points in each sweep must be $\geq (2 \cdot \text{span} / \text{RBW})$, which may require that the measurement range defined by the preceding start and stop frequencies be subdivided, depending on the available number of measurement points of the spectrum analyzer. Trace average at least 10 traces in power averaging (i.e., rms) mode.
 - 6) Sweep time = auto-couple.
 - 7) Use the peak marker function to identify the highest amplitude level over each measured frequency range. Record the frequency and amplitude and capture a plot for inclusion in the test report.
 - 8) Reset the analyzer start frequency to the upper band/block edge frequency plus 100 kHz or 1 MHz, as specified in the applicable rule part, and the analyzer stop frequency to 10 times the highest frequency of the fundamental emission. Note that the number of measurement points in each sweep must be $\geq (2 \cdot \text{span} / \text{RBW})$ which may require that the measurement range defined by the start and stop frequencies above be subdivided, depending on the available number of measurement points provided by the spectrum analyzer.
 - 9) Use the peak marker function to identify the highest amplitude level over each of the measured frequency ranges. Record the frequency and amplitude and capture a plot for inclusion in the test report.
- e) Repeat b) through d) for each supported frequency band of operation.

Special requirements for uplink Band 776-787MHz / downlink Band 746-757MHz:

For conducted spurious test: RBW = 6.25kHz, RBW = $3 \cdot \text{RBW}$ for conducted spurious test;

For EIRP test: RBW = 700Hz, RBW = $3 \cdot \text{RBW}$ (Narrowband);
RBW = 1MHz, RBW = $3 \cdot \text{RBW}$ (Wideband);

8.4 Test Protocol

Temperature : 25 °C
Relative Humidity : 55 %

Signal Type	Mode	Band (MHz)	Max reading (dBm)	Limit (dBm)
LTE	Uplink	1710-1755	<-19	-13
	Uplink	824-849	<-19	
	Uplink	776-787	<-19	
	Uplink	704-716	<-19	
	Uplink	1850-1910	<-19	
	Downlink	2110-2155	<-19	
	Downlink	869-894	<-19	
	Downlink	746-757	<-19	
	Downlink	734-746	<-19	
	Downlink	1930-1990	<-19	

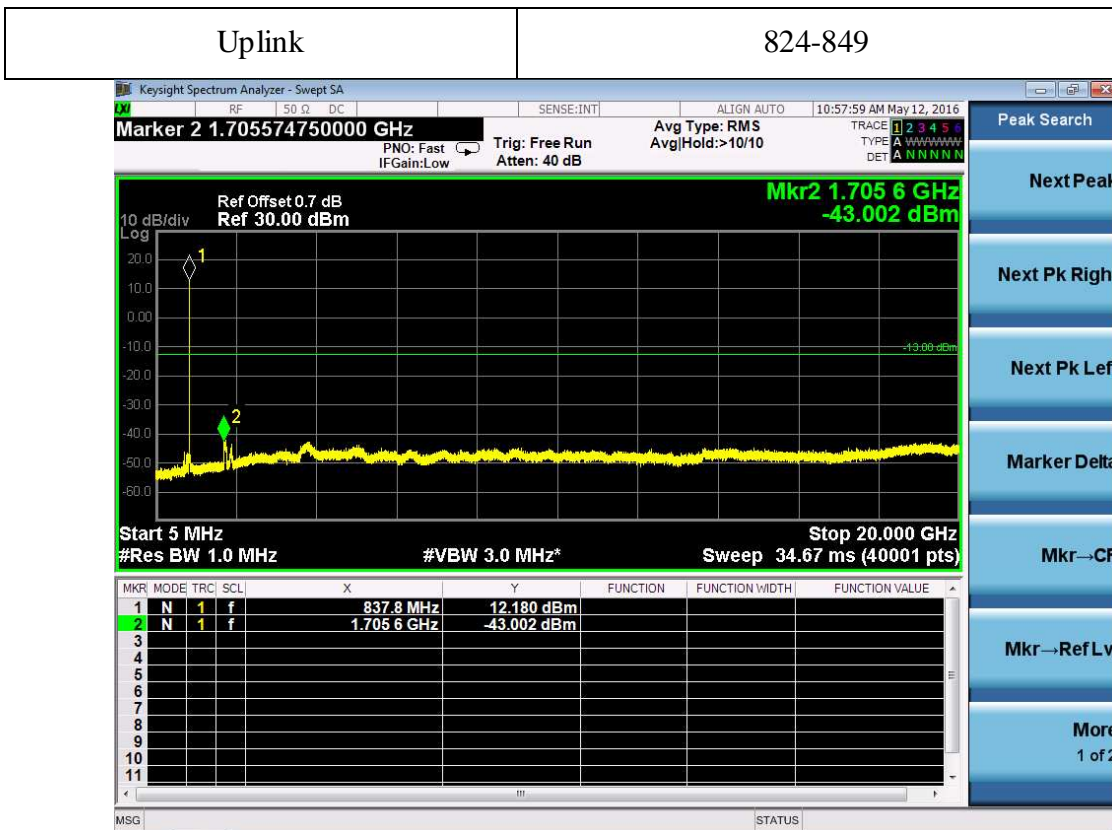
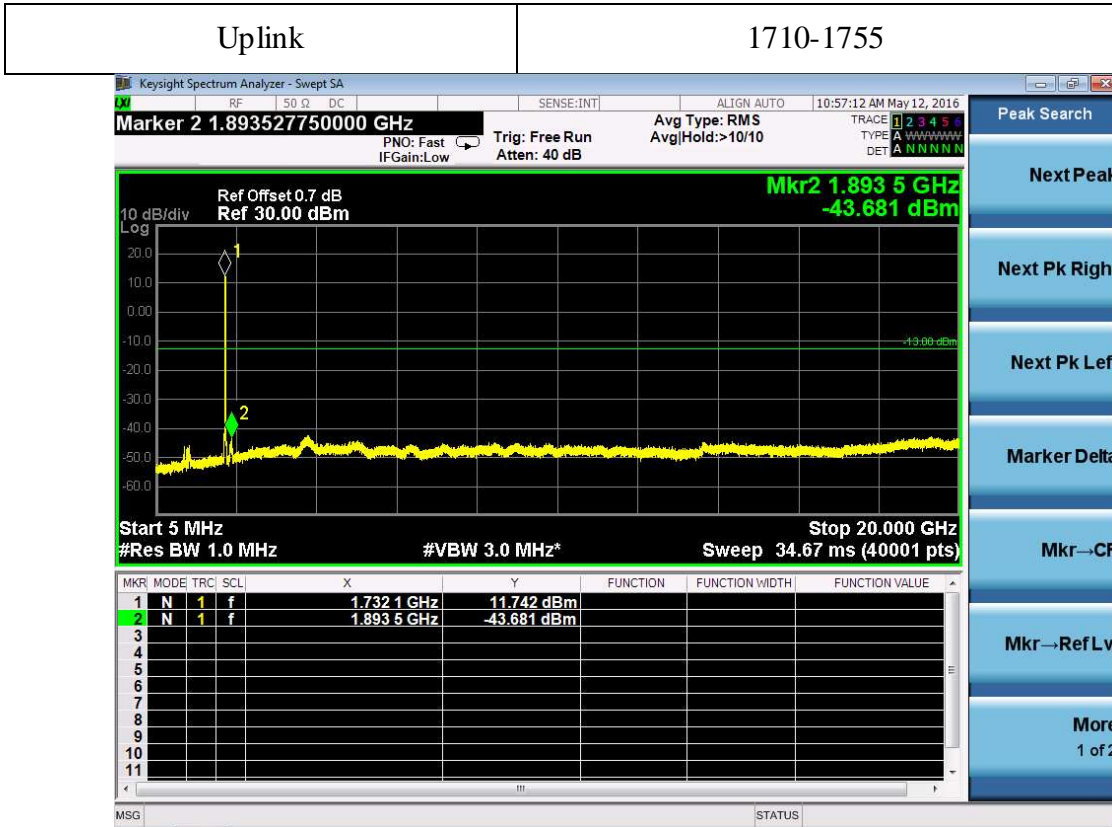

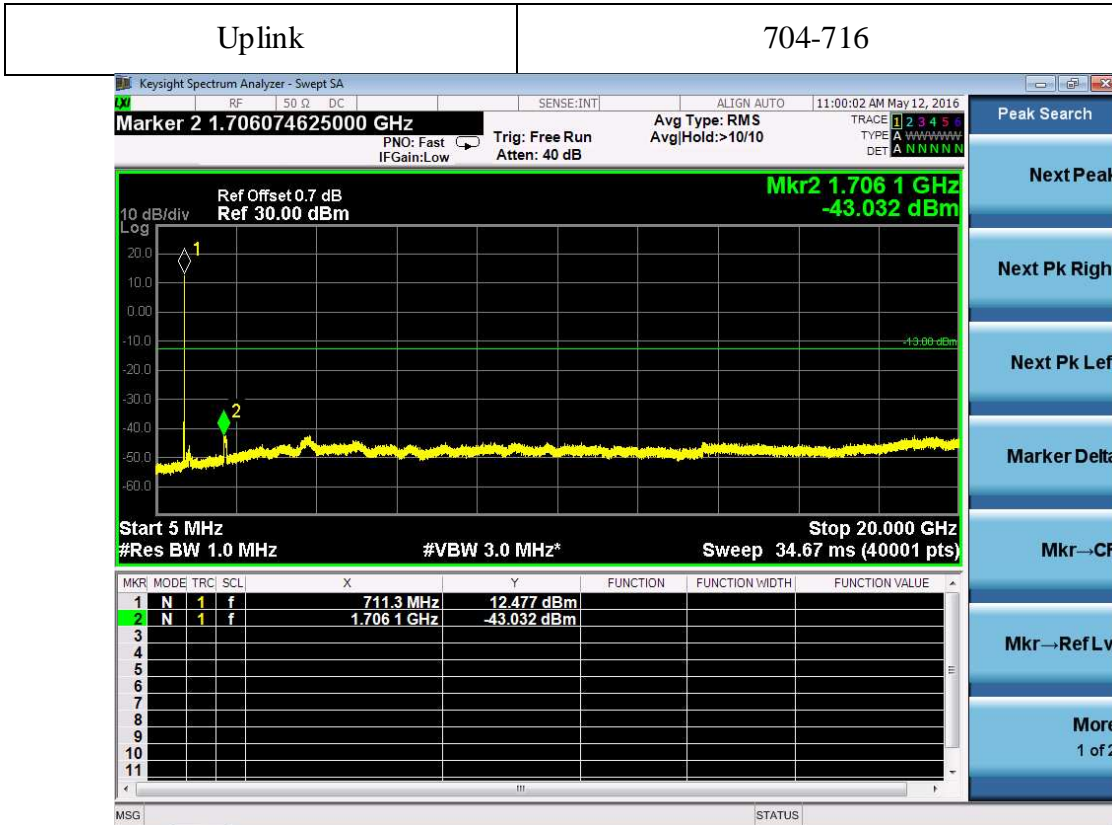
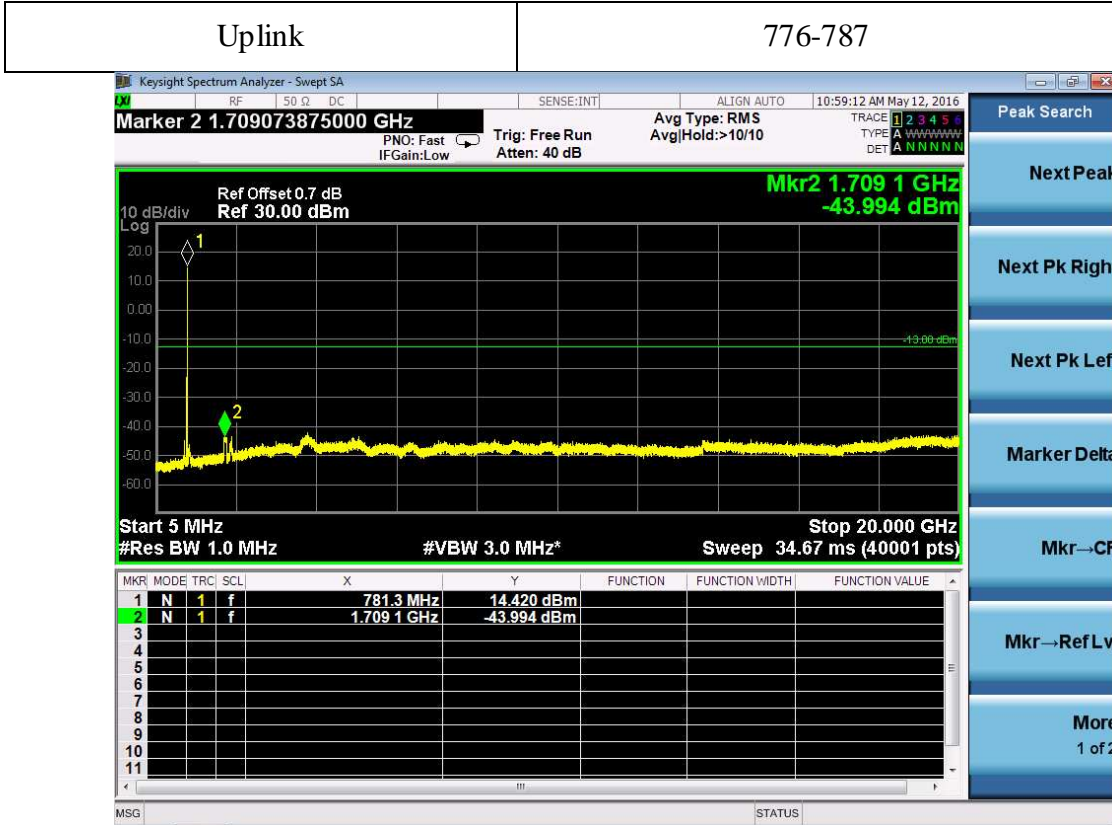

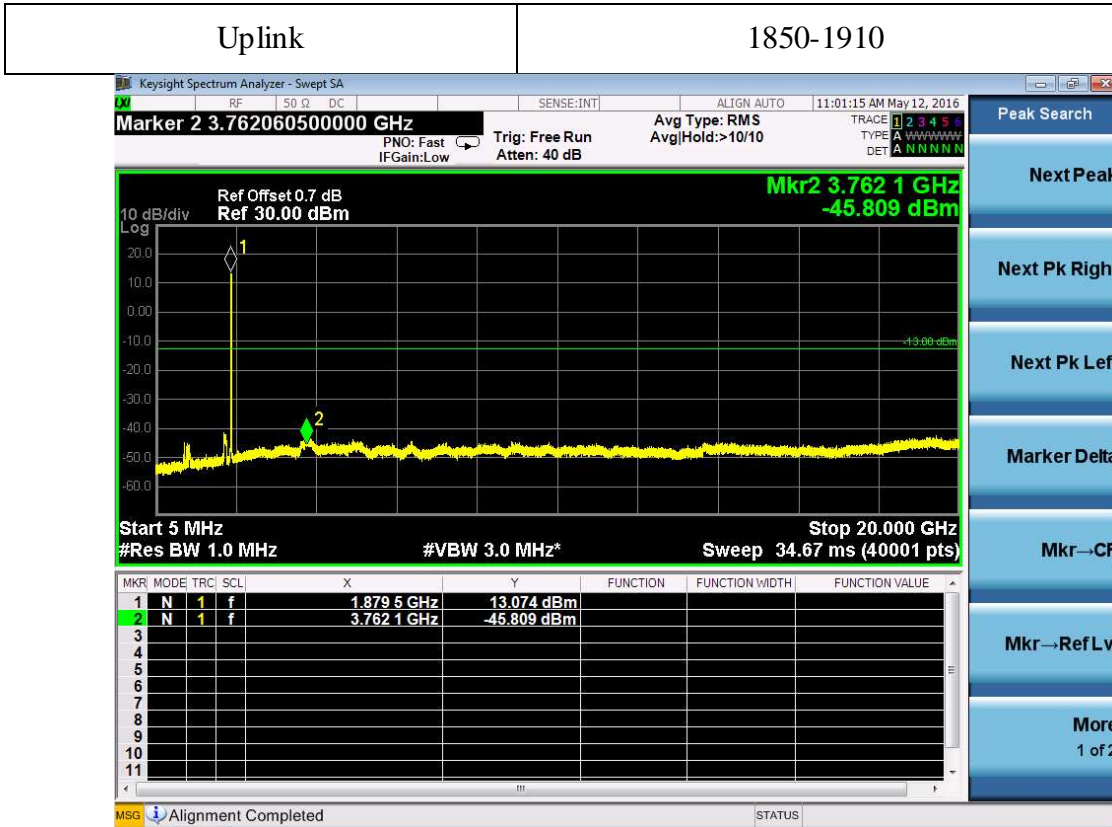

Downlink	2110-2155
----------	-----------

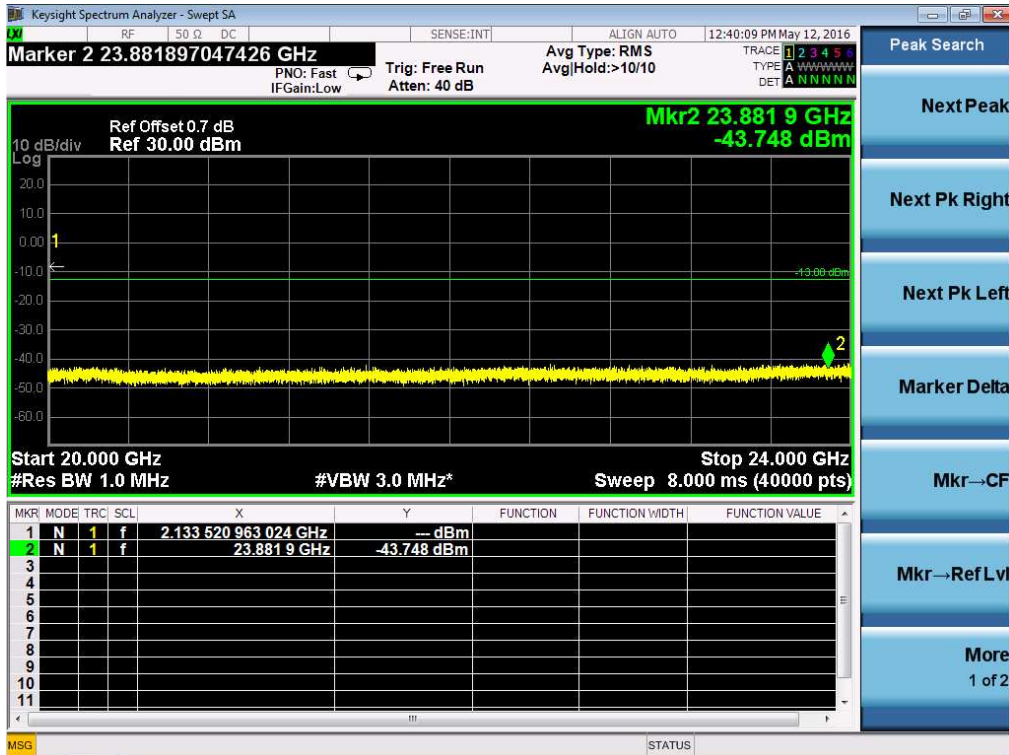
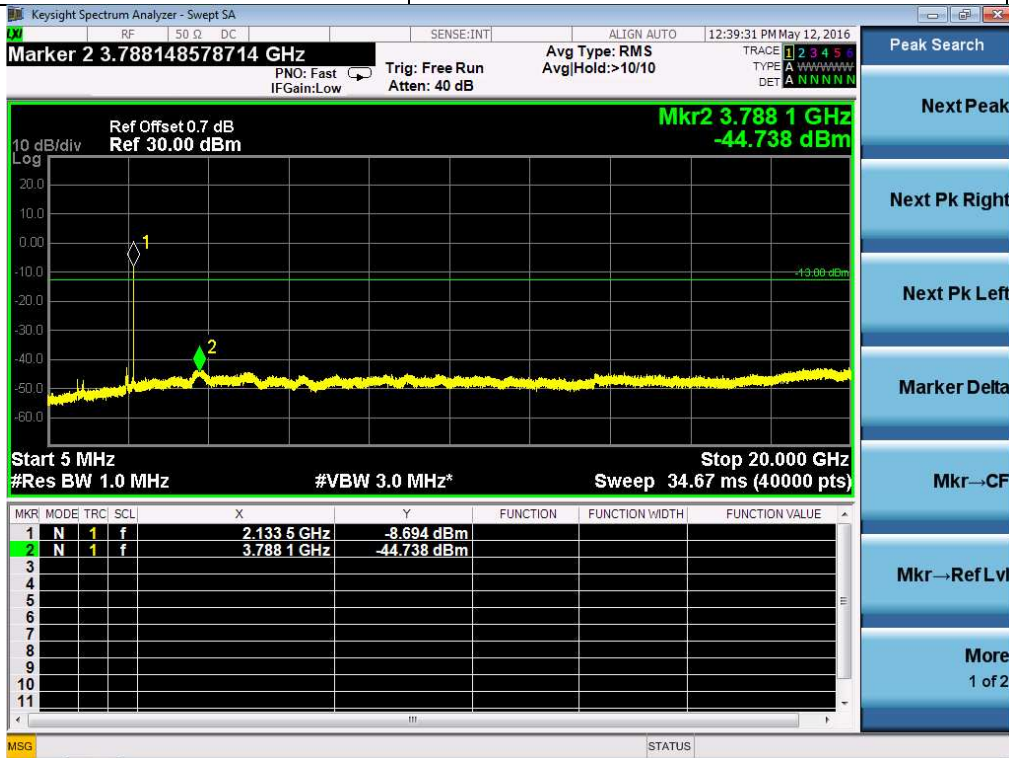

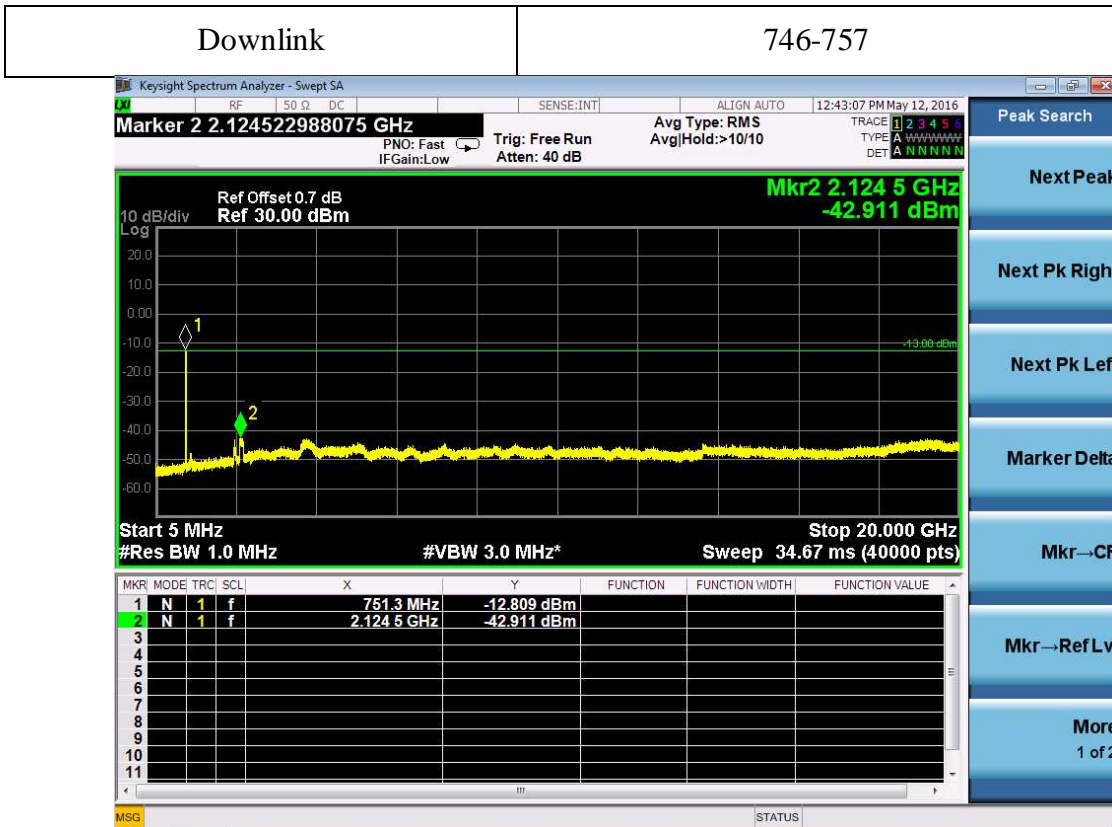
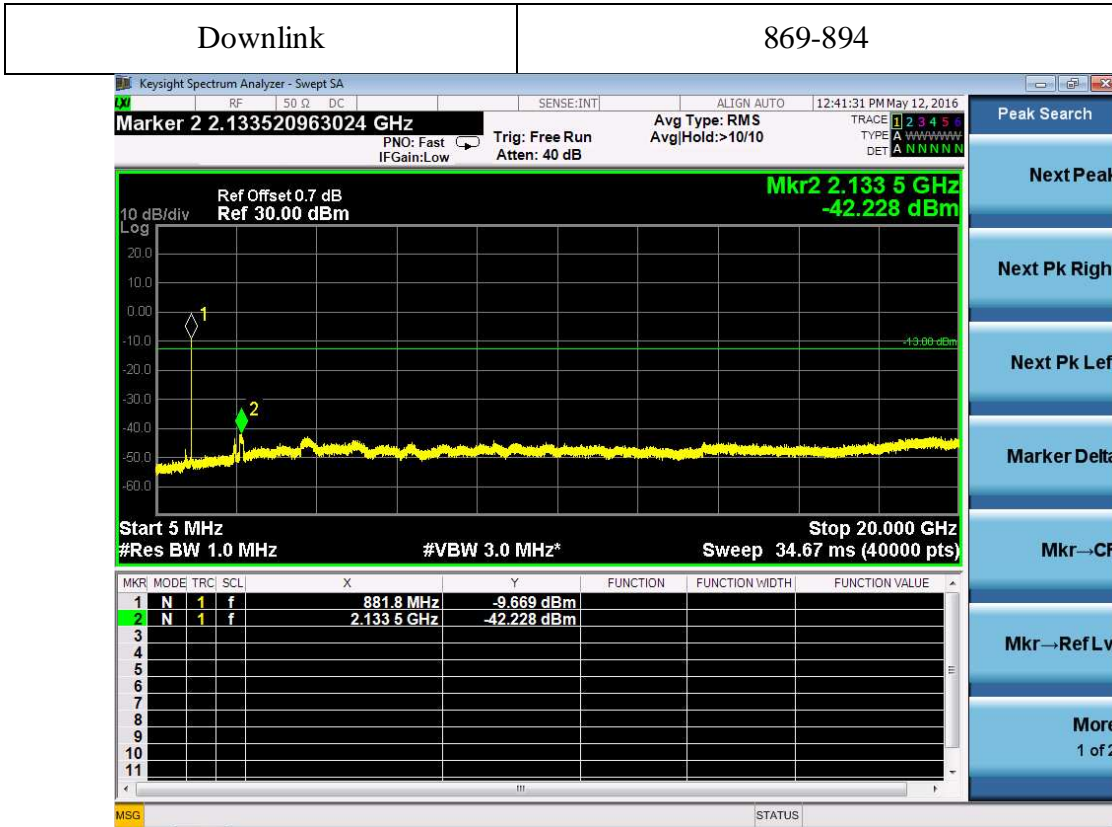

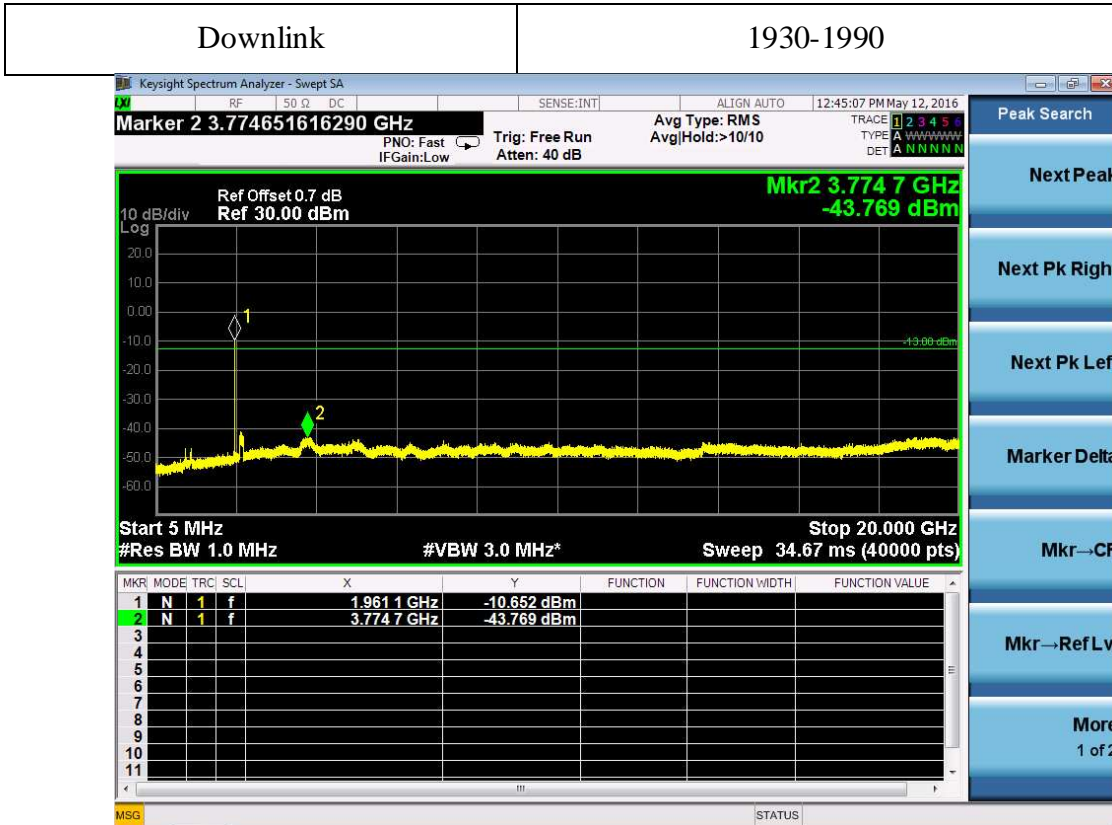
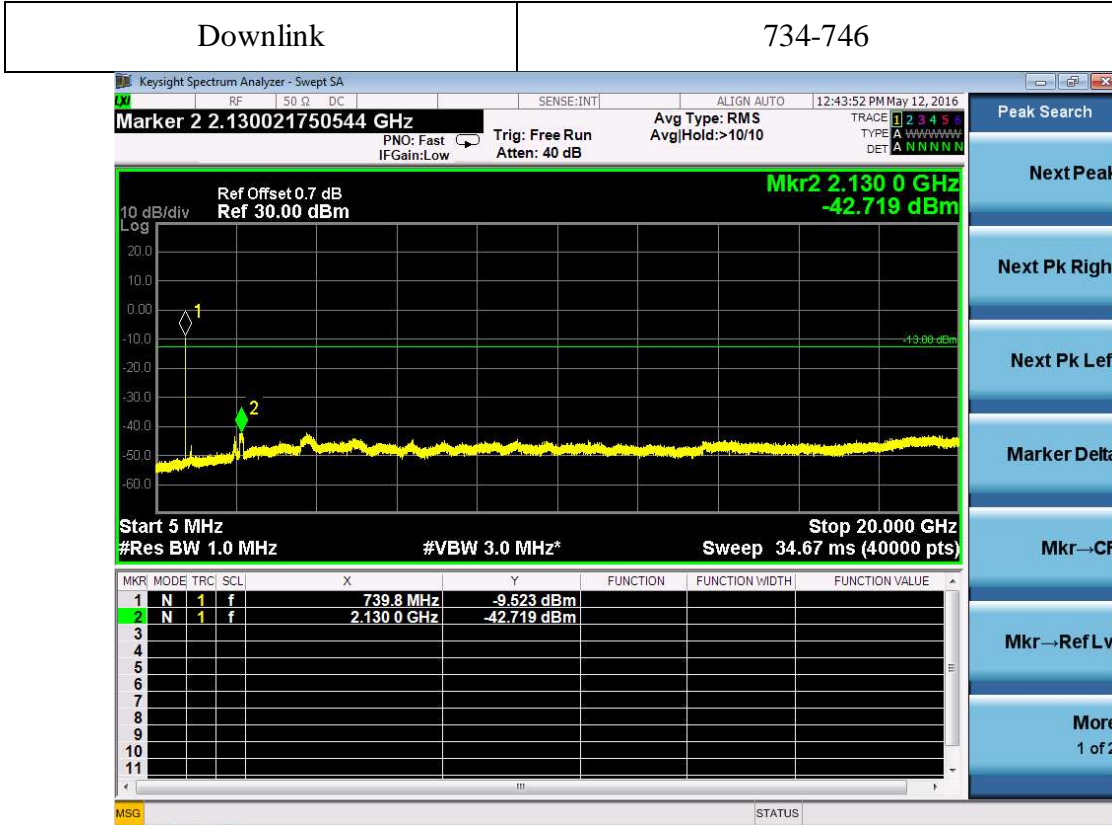

Special spurious requirements of FCC part 27.53(c)

Mode	Spurious Range (MHz)	Max reading (dBm)	Limit (dBm)
Uplink Band 776 - 787 MHz	763 - 775	<-52	-46
Uplink Band 776 - 787 MHz	793 - 805	<-52	-46
Downlink Band 746 - 757 MHz	763 - 775	<-52	-46
Downlink Band 746 - 757 MHz	793 - 805	<-52	-46

Special EIRP requirements of FCC part 27.53(e)

Mode	Spurious Range (MHz)	Max conducted reading (dBm)	Ant Gain (dBi)	EIRP (dBm)	Limit (dBm)
Uplink Band 776 - 787 MHz	1559 – 1610 (Wideband)	<-55	7.77	<-47.23	-40
Uplink Band 776 - 787 MHz	1559 – 1610 (Narrowband)	<-65	7.77	<-57.23	-50
Downlink Band 746 - 757 MHz	1559 – 1610 (Wideband)	<-55	5.00	<-50.00	-40
Downlink Band 746 - 757 MHz	1559 – 1610 (Narrowband)	<-65	5.00	<-60.00	-50

Note 1: EIRP = Max conducted reading + Antenna Gain
Note 2: Here the 'Ant gain' has included cable loss of antenna feeder cable.

9. Noise limits

Test result: Pass

9.1 Test limit

Noise Power = $-102.5 + \text{LOG}_{10}(\text{Band Center Frequency}) * 20$
Variable Noise of uplink mode = $-103\text{dBm/MHz} - \text{RSSI}$

9.2 Test Configuration

Noise limit

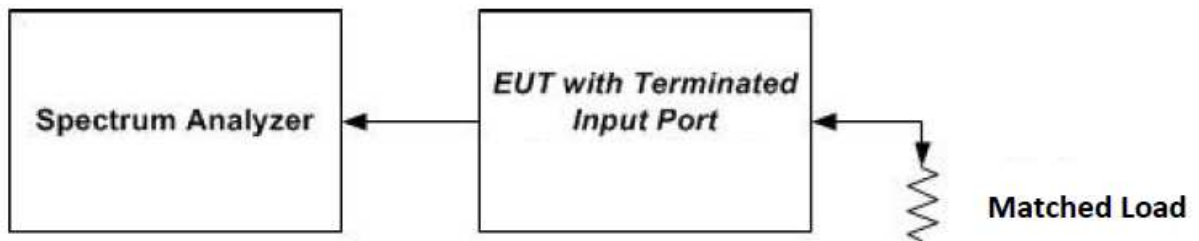

Uplink noise power measurement in the presence of a downlink signal

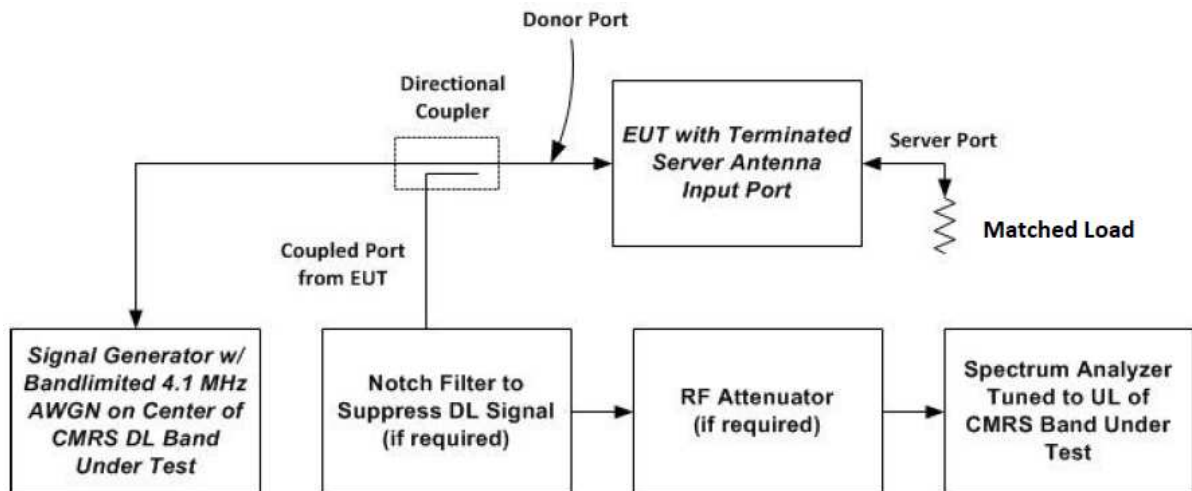

9.3 Test procedure and test setup

Maximum transmitter noise power level

- a) Connect the EUT to the test equipment as shown in 'Noise limit'. Begin with the uplink output (donor) port connected to the spectrum analyzer. When measuring downlink noise, connect the downlink output (server) port to the spectrum analyzer.
- b) Set the spectrum analyzer RBW to 1 MHz with the VBW $\geq 3 \cdot \text{RBW}$.
- c) Select the power averaging (rms) detector and trace average over at least 100 traces.
- d) Set the center frequency of the spectrum analyzer to the center of the CMRS band under test with the span $\geq 2 \cdot \text{the CMRS band}$.
- e) Measure the maximum transmitter noise power level.
- f) Save the spectrum analyzer plot as necessary for inclusion in the final test report.
- g) Repeat b) to f) for all operational uplink and downlink bands.
- h) Connect the EUT to the test equipment as shown in 'Uplink noise power measurement in the presence of a downlink signal' for uplink noise power measurement in the presence a downlink signal. Affirm the coupled path of the RF coupler is connected to the spectrum analyzer.
- i) Configure the signal generator for AWGN operation with a 99% OBW of 4.1MHz.
- j) Set the spectrum analyzer RBW for 1 MHz, VBW $\geq 3 \cdot \text{RBW}$, with a power averaging (rms) detector with at least 100 trace averages.
- k) Set the center frequency of the spectrum analyzer to the center of the CMRS band under test, with the span $\geq 2 \cdot \text{the CMRS band}$. This shall include all spectrum blocks in the particular CMRS band under test.
- l) For uplink noise measurements, set the spectrum analyzer center frequency for the uplink band under test, and tune the signal generator to the center of the paired downlink band.
- m) Measure the maximum transmitter noise power level while varying the downlink signal generator output level from -90 dBm to -20 dBm, as measured at the input port (i.e., downlink signal level at the booster donor port node of 'Uplink noise power measurement in the presence of a downlink signal', in 1 dB steps inside the RSSI-dependent region, and in 10 dB steps outside the RSSI-dependent region. Report the six values closest to the limit, with at least two points within the RSSI-dependent region of the limit.
- n) Repeat h) through m) for all operational uplink bands.

Variable uplink noise timing

Variable uplink noise timing is to be measured as follows, using the test setup shown in 'Uplink noise power measurement in the presence of a downlink signal'.

- a) Set the spectrum analyzer to the uplink frequency to be measured.
- b) Set the span to 0 Hz, with a sweep time of 10 seconds.
- c) Set the power level of signal generator to the lowest level of the RSSI-dependent noise.
- d) Select MAX HOLD and increase the power level of signal generator by 10 dB for mobile boosters, and 20 dB for fixed boosters.
- e) Confirm that the uplink noise decreases to the specified level within 1 second for mobile devices, and within 3 seconds for fixed devices.
- f) Repeat a) to e) for all operational uplink bands.



g) Include plots and summary table in test report.

9.4 Test Protocol

Temperature : 25 °C
Relative Humidity : 55 %

Noise Power limit calculation		
Band (MHz)	Central Frequency of Band (MHz)	Calculated Limit
1710-1755	1732.5	-37.73
824-849	836.5	-44.05
776-787	781.5	-44.64
704-716	710	-45.47
1850-1910	1880	-37.02
2110-2155	2132.5	-35.92
869-894	881.5	-43.60
746-757	751.5	-44.98
734-746	740	-45.12
1930-1990	1960	-36.65

Note: Calculated Limit = $-102.5 + \text{LOG}_{10}(\text{Band Center Frequency}) * 20$

Lowest RSSI value of RSSI dependent Zone calculation	
Band (MHz)	Calculated Lowest RSSI value (dBm)
1710-1755	-65.27
824-849	-58.95
776-787	-58.36
704-716	-57.53
1850-1910	-65.98

Note: Calculated Lowest RSSI value = $-103 - \text{Noise Power limit of above table}$

Noise Power Test Result				
Mode	Band (MHz)	Max reading (dBm)	Limit (dBm)	Margin (dB)
Uplink	1710-1755	-42.72	-37.73	4.99
Uplink	824-849	-50.38	-44.05	6.33
Uplink	776-787	-50.24	-44.64	5.60
Uplink	704-716	-48.76	-45.47	3.29
Uplink	1850-1910	-45.35	-37.02	8.33
Downlink	2110-2155	-42.07	-35.92	6.15
Downlink	869-894	-50.12	-43.60	6.52
Downlink	746-757	-48.95	-44.98	3.97
Downlink	734-746	-49.31	-45.12	4.19
Downlink	1930-1990	-44.18	-36.65	7.53

Uplink, 1710-1755MHz

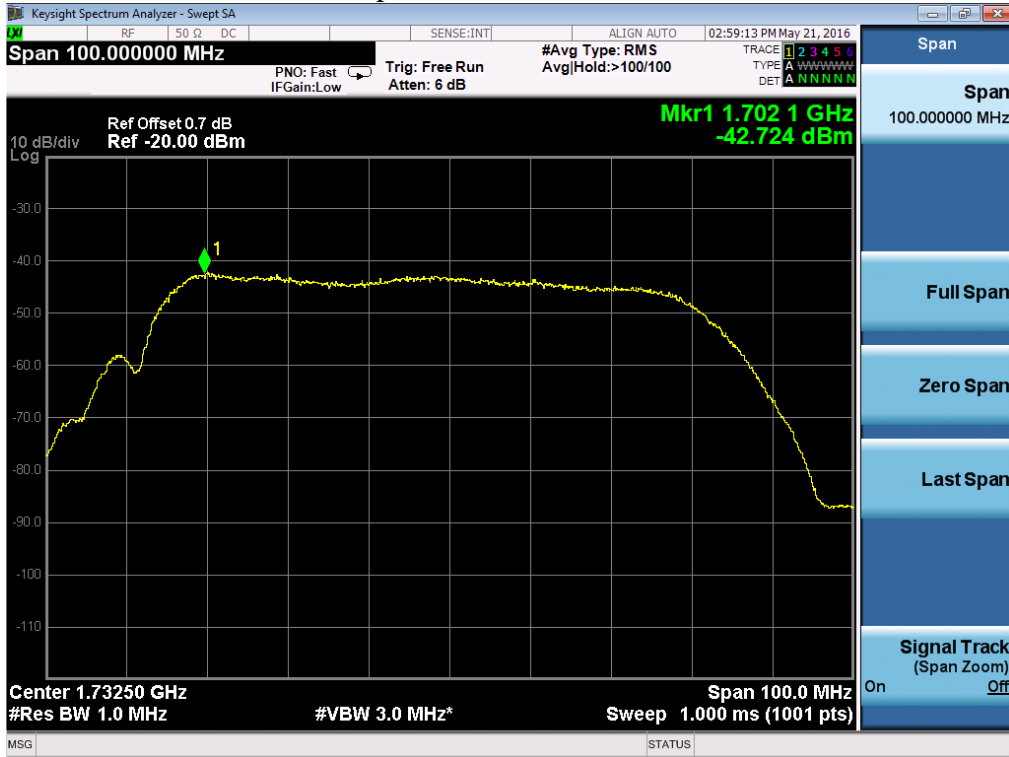

Uplink, 824-849MHz

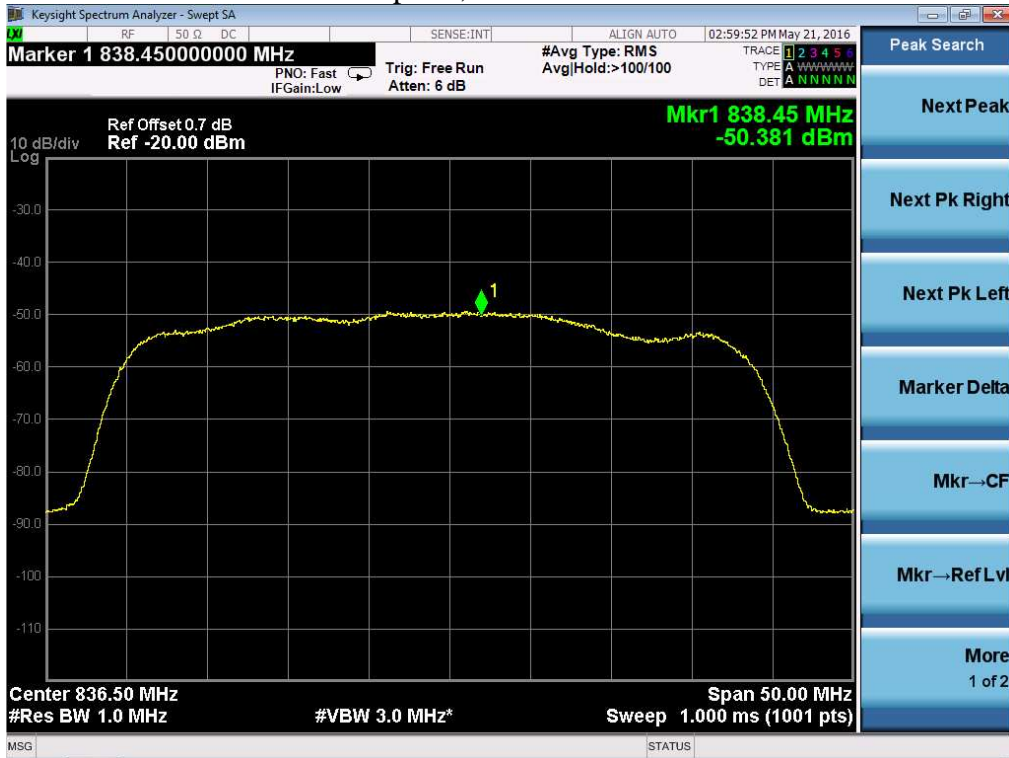

Uplink, 776-787MHz



Uplink, 704-716MHz



Uplink, 1850-1910MHz

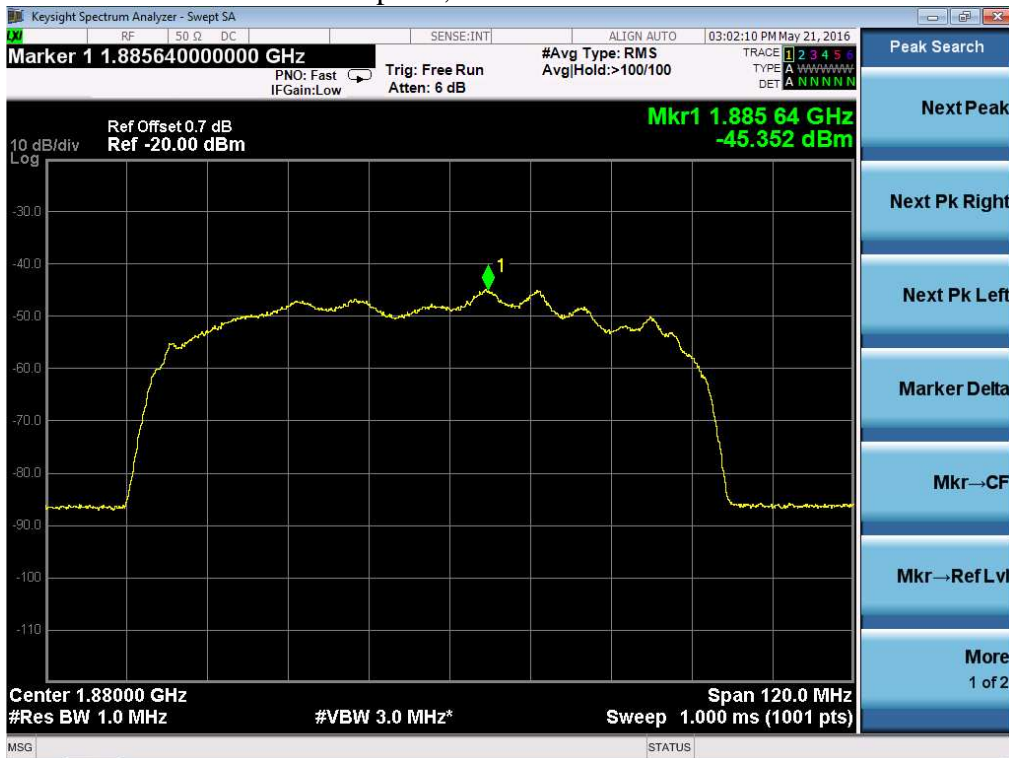

Downlink, 2110-2155MHz



Downlink, 869-894MHz

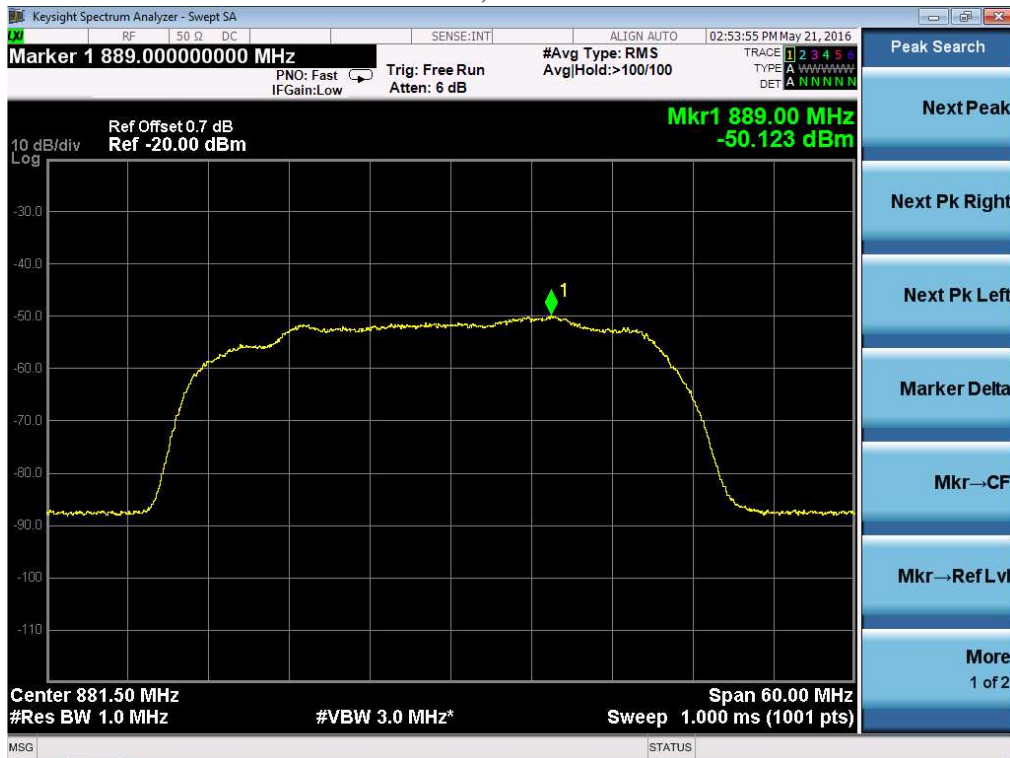

Downlink, 746-757MHz



Downlink, 734-746MHz



Downlink, 1930-1990MHz



Uplink Noise Timing Test Result				
Mode	Band (MHz)	Max reading (s)	Limit (s)	Margin (s)
Uplink	1710-1755	0.28	3	2.72
Uplink	824-849	0.38	3	2.62
Uplink	776-787	0.20	3	2.80
Uplink	704-716	0.17	3	2.83
Uplink	1850-1910	0.53	3	2.47

Uplink, 1710-1755MHz

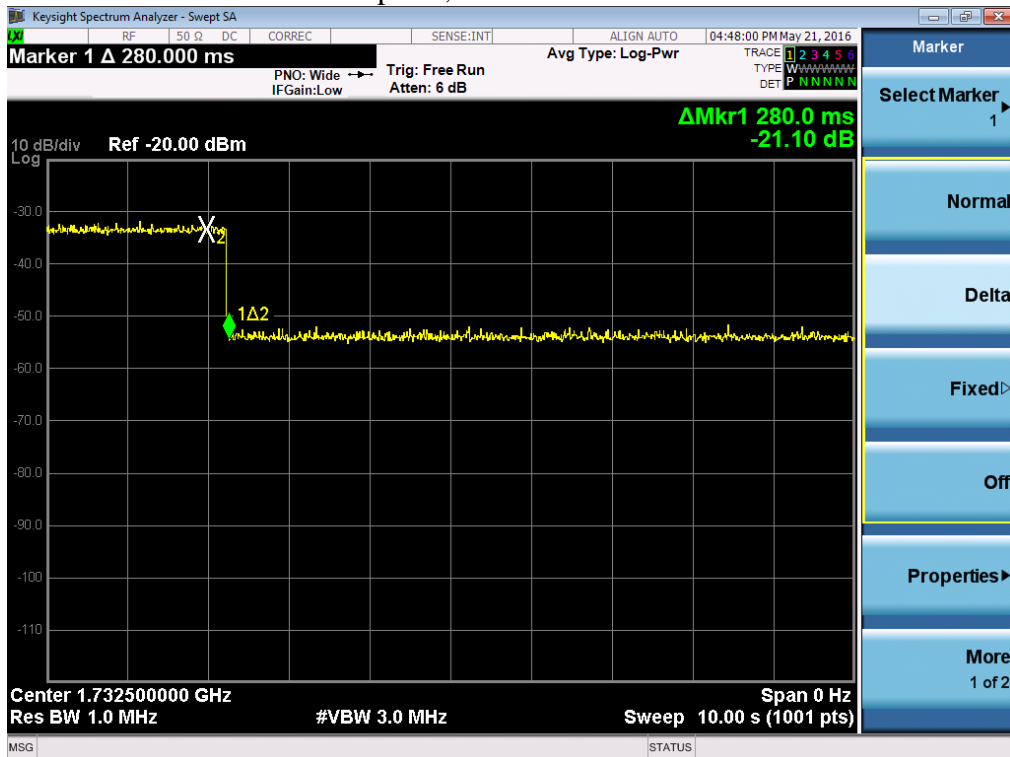

Uplink, 824-849MHz

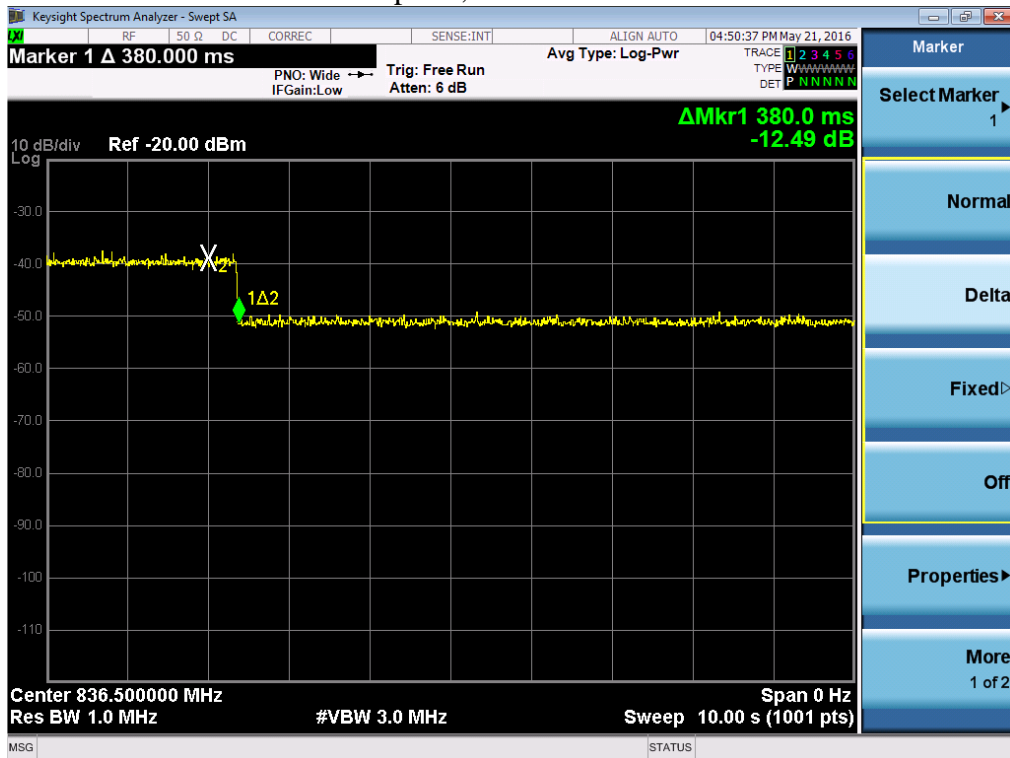

Uplink, 776-787MHz

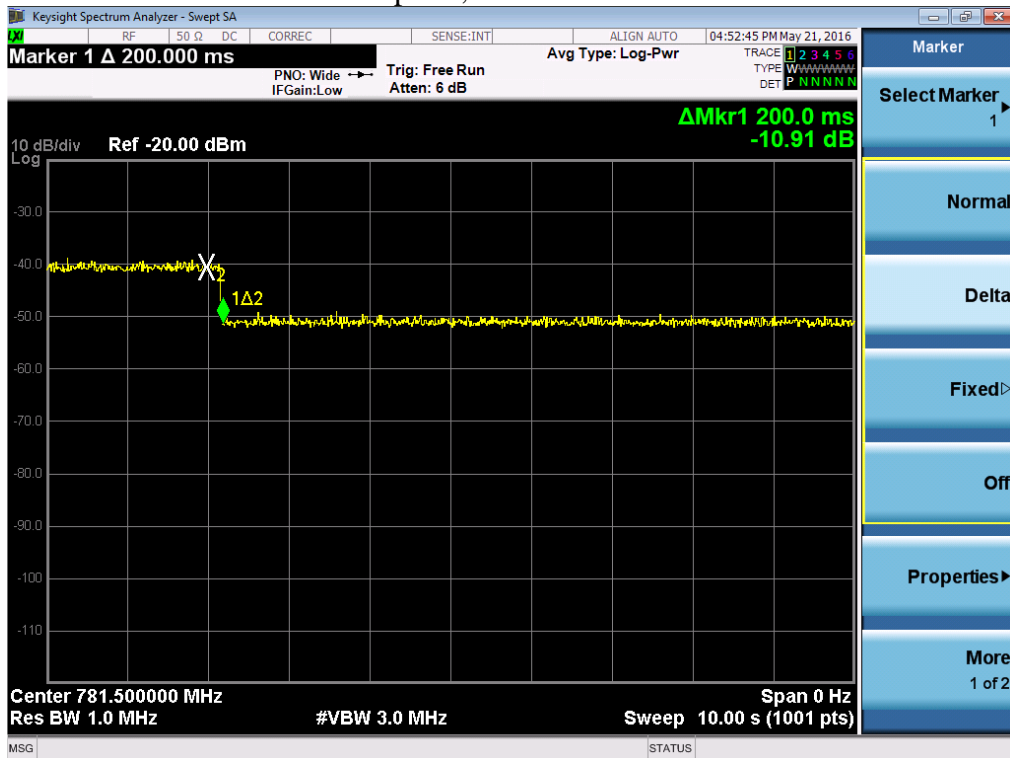

Uplink, 704-716MHz

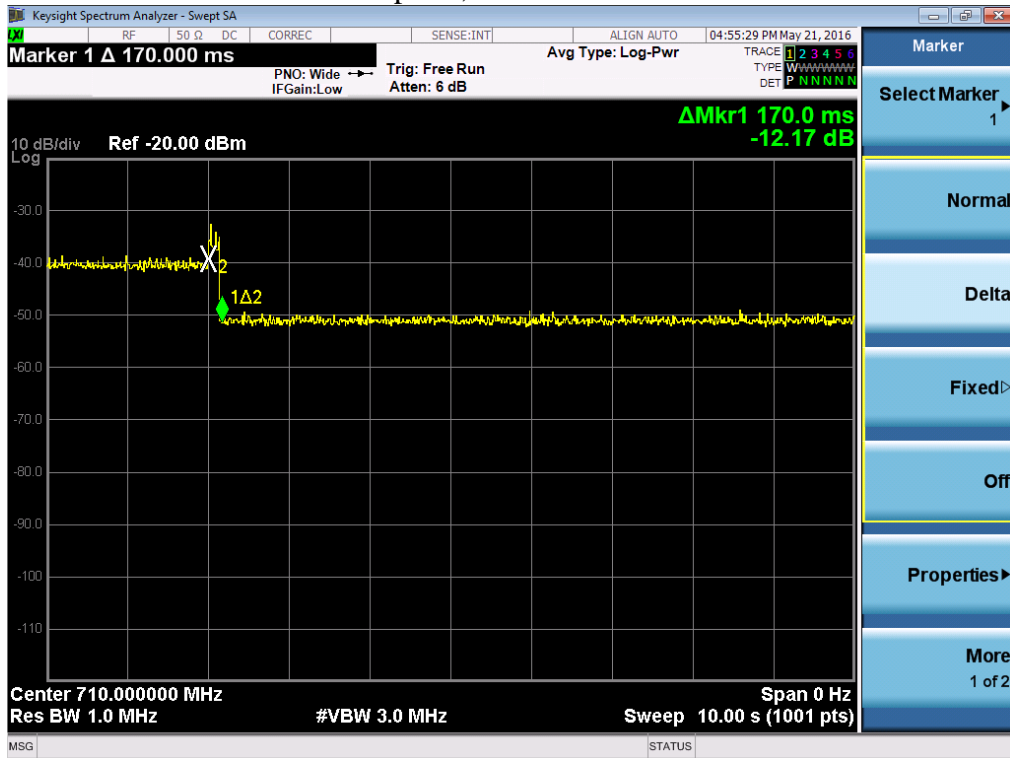

Uplink, 1850-1910MHz



Variable Uplink Noise Limit Test Result					
Mode	Band (MHz)	RSSI (dBm)	Measured Noise (dBm)	Limit (dBm)	Margin (dB)
Uplink	1710-1755	-81.0	-44.70	-37.73	6.97
		-80.0	-44.20	-37.73	6.47
		-79.0	-44.20	-37.73	6.47
		-78.0	-44.30	-37.73	6.57
		-60.0	-47.50	-43.00	4.50
		-58.0	-49.70	-45.00	4.70
	824-849	-67.0	-52.10	-44.05	8.05
		-66.0	-52.30	-44.05	8.25
		-65.0	-51.90	-44.05	7.85
		-64.0	-51.70	-44.05	7.65
		-54.0	-53.60	-49.00	4.60
		-52.0	-55.70	-51.00	4.70
	776-787	-66.0	-52.50	-44.64	7.86
		-65.0	-52.50	-44.64	7.86
		-64.0	-52.50	-44.64	7.86
		-63.0	-52.50	-44.64	7.86
		-53.0	-55.00	-50.00	5.00
		-51.0	-57.10	-52.00	5.10
	704-716	-71.0	-52.80	-45.47	7.33
		-69.0	-52.40	-45.47	6.93
		-68.0	-52.10	-45.47	6.63
		-64.0	-52.20	-45.47	6.73
		-52.0	-55.30	-51.00	4.30
		-50.0	-57.10	-53.00	4.10
	1850-1910	-71.0	-48.20	-37.02	11.18
		-70.0	-47.90	-37.02	10.88
		-69.0	-47.80	-37.02	10.78
-68.0		-48.10	-37.02	11.08	
-58.0		-50.10	-45.00	5.10	
-56.0		-51.90	-47.00	4.90	

10. Uplink inactivity

Test result: Pass

10.1 Test limit

The EUT was powered on and the time for the uplink to return to an inactive state was measured using the DELTA MARKER method to ensure that it was less than 300 seconds

10.2 Test Configuration

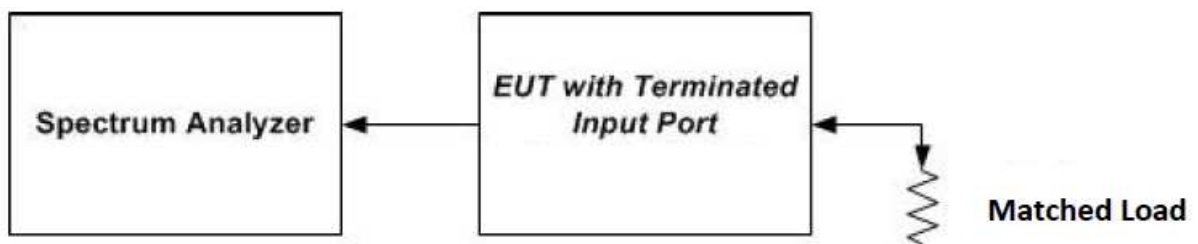

10.3 Test procedure and test setup

- a) Connect the EUT to the test equipment with the uplink output (donor) port connected to the spectrum analyzer.
NOTE—Some signal boosters will require a signal generator input because they will not operate unless a signal is received at the input terminals. If this is the case for the setup connecting a signal generator at the server port, then cycle the RF output of the signal generator to simulate this function.
- b) Select the power averaging (rms) detector.
- c) Set the spectrum analyzer RBW for 1 MHz with the VBW $\geq 3 \times$ RBW.
- d) Set the center frequency of the spectrum analyzer to the center of the uplink operational band.
- e) Set the span for 0 Hz with a single sweep time for a minimum of 330 seconds.
- f) Start to capture a new trace using MAX HOLD.
- g) After approximately 15 seconds, turn on the EUT power.
- h) After the full spectrum analyzer trace is complete, place a MARKER on the leading edge of the pulse, then use the DELTA MARKER METHOD to measure the time until the uplink becomes inactive.
- i) Affirm that the noise level is below the uplink inactivity noise power limit, as specified by the rules.
- j) Capture the plot for inclusion in the test report.
- k) Measure noise using procedures in a) to f).
- l) Repeat d) through k) for all operational uplink bands.

10.4 Test Protocol

Temperature : 25 °C
Relative Humidity : 55 %

Mode	Band (MHz)	Measured Time (s)	Limit (s)	Margin (s)
Uplink	1710-1755	260.3	300	39.70
Uplink	824-849	260.7	300	39.30
Uplink	776-787	260.7	300	39.30
Uplink	704-716	260.4	300	39.60
Uplink	1850-1910	262.0	300	38.00

Uplink, 1710-1755MHz

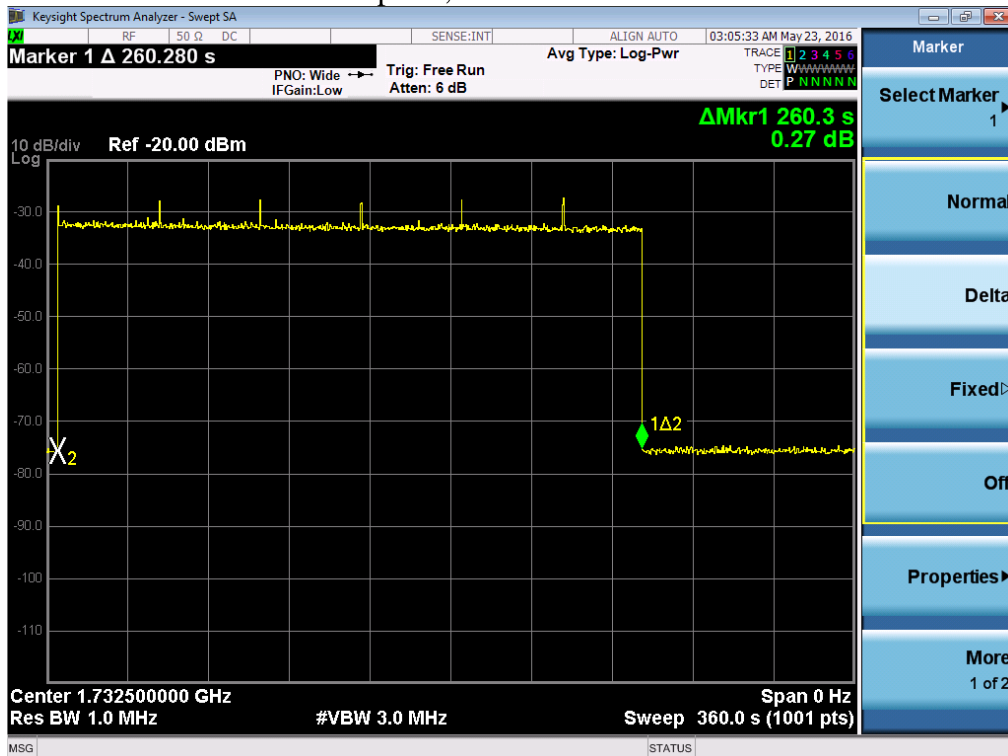

Uplink, 824-849MHz

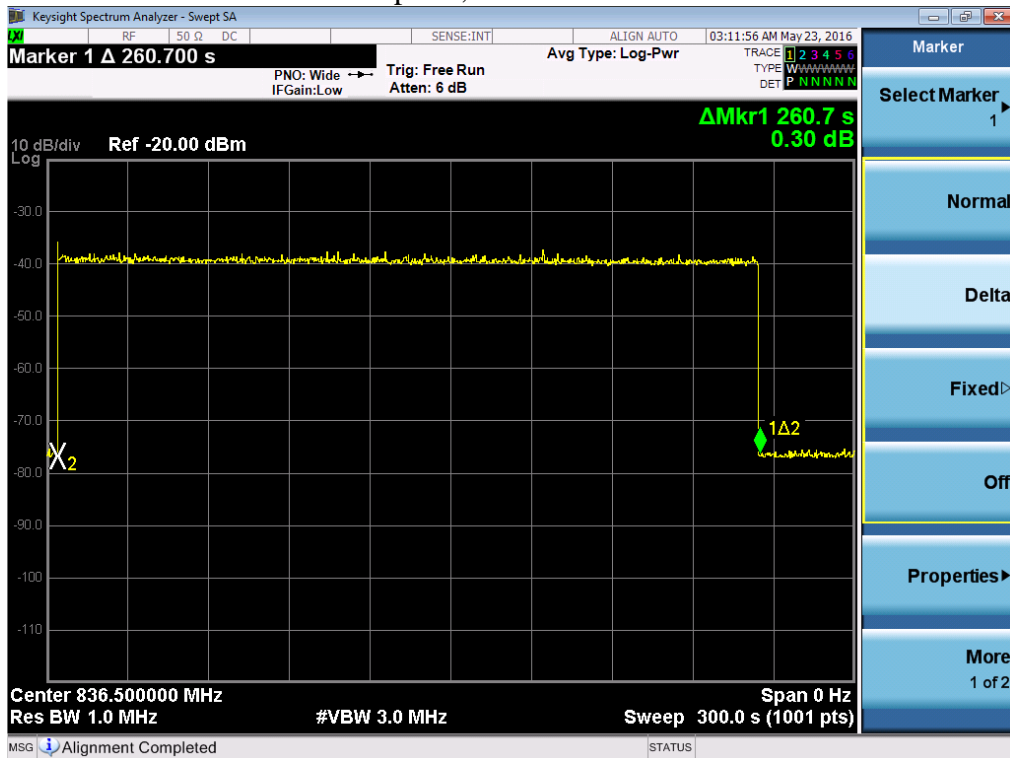

Uplink, 776-787MHz

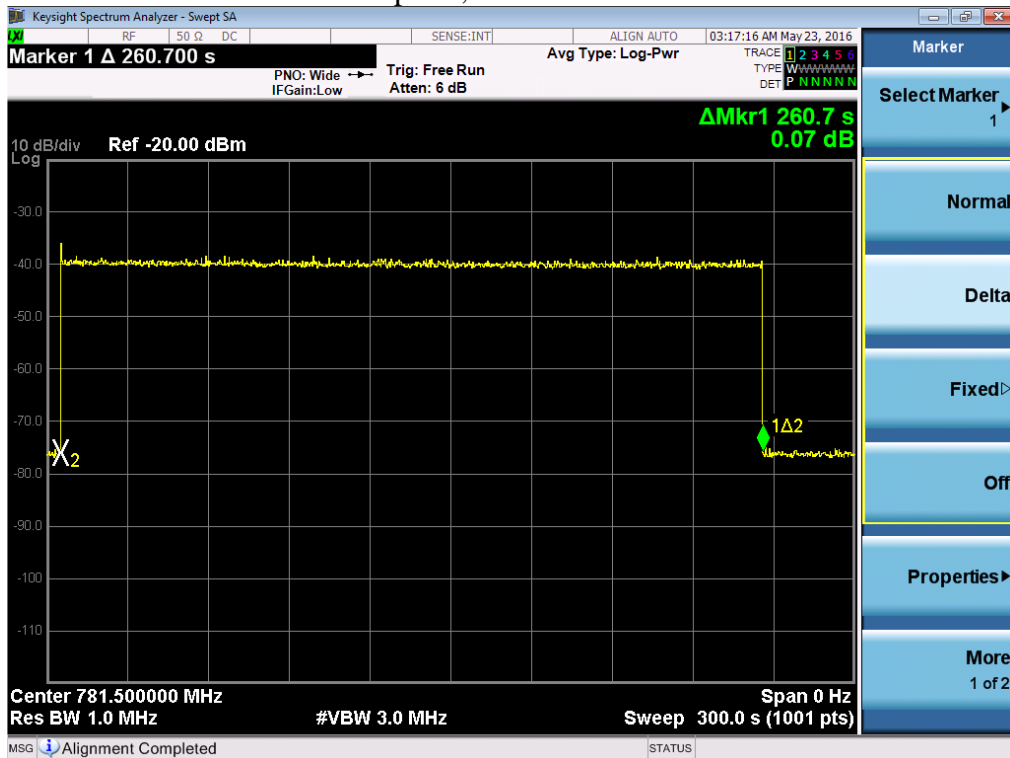

Uplink, 704-716MHz

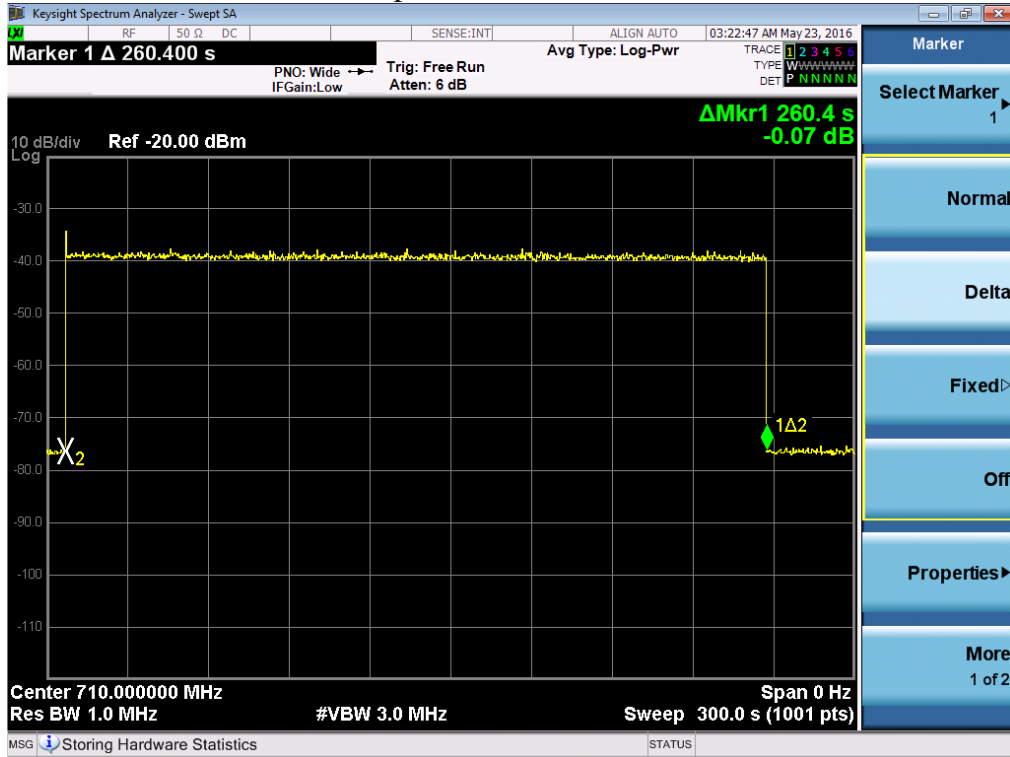

Uplink, 1850-1910MHz

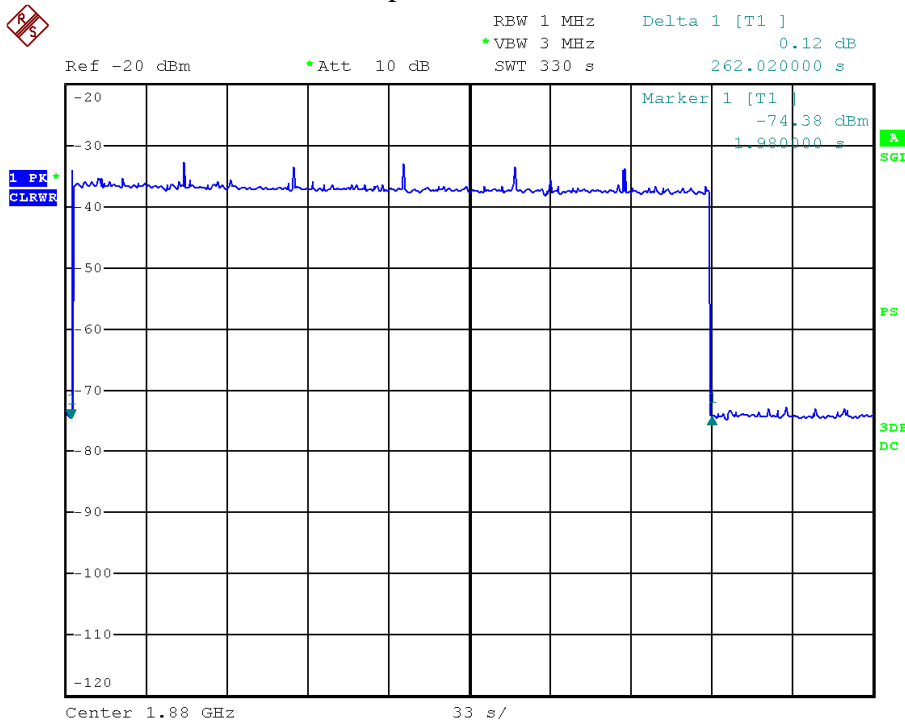

Date: 21.MAY.2016 09:59:52

11. Variable booster gain

Test result: Pass

11.1 Test limit

Variable Gain = -34 dB - RSSI + MSCL

11.2 Test Configuration

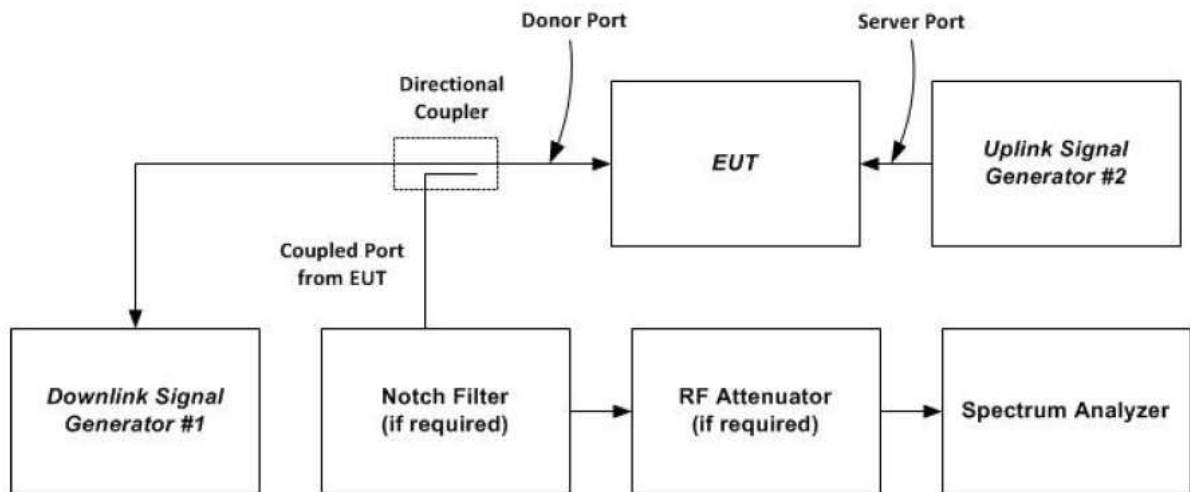

11.3 Test procedure and test setup

- a) Connect the EUT to the test equipment with the uplink output (donor) port connected to signal generator #1. Affirm that the coupled path of the RF coupler is connected to the spectrum analyzer.
- b) Configure downlink signal generator #1 for AWGN operation with a 99% OBW of 4.1 MHz, tuned to the center of the operational band.
- c) Set the power level and frequency of signal generator #2 to a value that is 5 dB below the AGC level. The signal type is AWGN with a 99% OBW of 4.1 MHz.
- d) Set RBW = 100 kHz.
- e) Set VBW \geq 300 kHz.
- f) Select the CHANNEL POWER measurement mode.
- g) Select the power averaging (rms) detector.
- h) Affirm that the number of measurement points per sweep $\geq (2*\text{span})/\text{RBW}$.
- i) Sweep time = auto couple or as necessary (but no less than auto couple value).
- j) Trace average at least 10 traces in power averaging (i.e., rms) mode.
- k) Measure the maximum channel power and compute maximum gain when varying the signal generator #1 output to a level from -90 dBm to -20 dBm, as measured at the input port (i.e., downlink signal level at the booster donor port node, in 1 dB steps inside the RSSI-dependent region, and 10 dB steps outside the RSSI-dependent region. Report the six values closest to the limit, including at least two points from within the RSSI-dependent region of operation. Additionally, document that the EUT provides equivalent uplink and downlink gain, and when operating in shutoff mode that the uplink and downlink gain is within the transmit power off mode gain limits.
- l) Repeat b) to k) for all operational uplink bands.

11.4 Test Protocol

Temperature : 25 °C
Relative Humidity : 55 %

Fixed Gain Limit calculation		
Band (MHz)	Central Frequency of Band (MHz)	Calculated Limit
1710-1755	1732.5	71.27
824-849	836.5	64.95
776-787	781.5	64.36
704-716	710	63.53
1850-1910	1880	71.98

Note: Gain Limit (dB) = 6.5 + 20Log(F_{MHz})

Lowest RSSI value of RSSI dependent Zone calculation	
Band (MHz)	Calculated Lowest RSSI value (dBm)
1710-1755	-63.38
824-849	-64.16
776-787	-64.16
704-716	-63.94
1850-1910	-63.38

Note: Calculated Lowest RSSI value = MSCL -34 - Fixed Gain limit of above table

Variable Uplink Noise Limit Test Result						
Mode	Band (MHz)	MSCL (dBm)	RSSI (dBm)	Gain reading (dB)	Gain Limit (dB)	Margin (dB)
Uplink	1710-1755	41.37	-65	59.37	72.37	13.00
		41.37	-64	59.37	71.37	12.00
		41.37	-63	59.37	70.37	11.00
		41.37	-62	59.37	69.37	10.00
		41.37	-52	50.18	59.37	9.19
		41.37	-50	48.59	57.37	8.78
	824-849	34.60	-65	53.92	65.60	11.68
		34.60	-64	53.95	64.60	10.65
		34.60	-63	53.95	63.60	9.65
		34.60	-60	54.40	60.60	6.20
		34.60	-51	51.00	51.60	0.60
		34.60	-49	48.50	49.60	1.10
	776-787	33.93	-63	52.88	62.93	10.05
		33.93	-62	52.82	61.93	9.11
		33.93	-60	52.78	59.93	7.15
		33.93	-58	52.51	57.93	5.42
		33.93	-52	50.75	51.93	1.18
		33.93	-50	49.39	49.93	0.54
	704-716	33.68	-63	54.12	62.68	8.56
		33.68	-60	53.99	59.68	5.69
		33.68	-59	53.89	58.68	4.79
		33.68	-57	53.68	56.68	3.00
		33.68	-55	53.34	54.68	1.34
		33.68	-53	51.98	52.68	0.69
	1850-1910	41.63	-64	54.28	71.63	17.35
		41.63	-60	54.25	67.63	13.38
		41.63	-57	53.86	64.63	10.77
		41.63	-54	50.99	61.63	10.64
		41.63	-48	45.01	55.63	10.62
		41.63	-47	43.94	54.63	10.69

12. Oscillation Detection

Test result: Pass

12.1 Test limit

The EUT uplink and downlink were tested to ensure that the presence of oscillation was detected and that the EUT output turned off within 300ms for the Uplink and 1s for the Downlink and remained off for 1 minute.

A EUT with test software was utilized to ensure that the EUT only had a maximum of 5 attempts at restart from oscillation before permanently shutting off.

12.2 Test Configuration

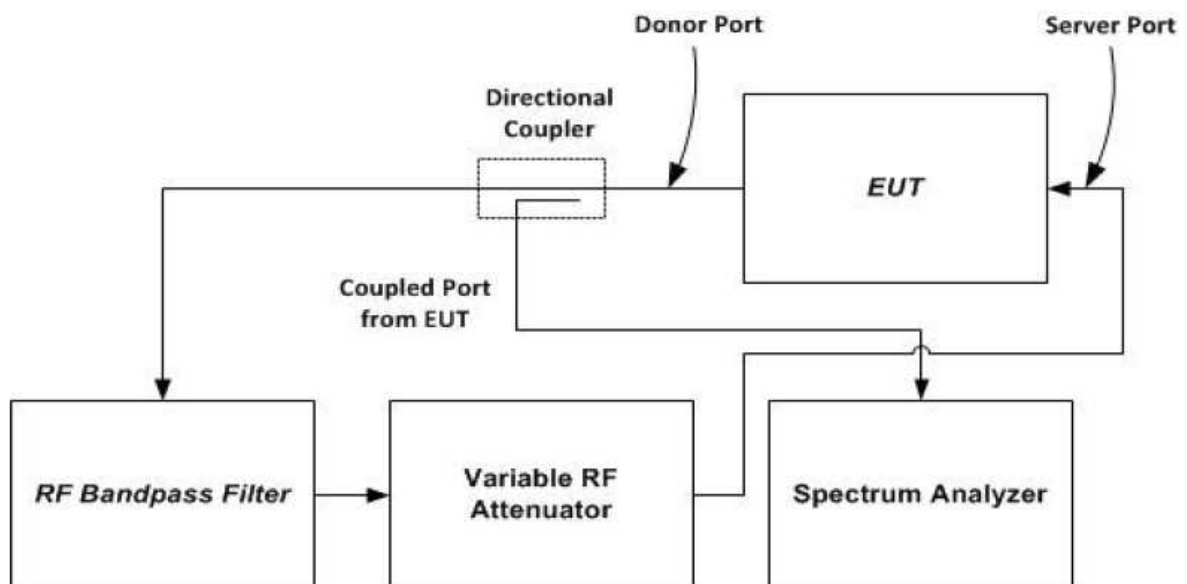

12.3 Test procedure and test setup

a) Connect the normal-operating mode EUT to the test equipment beginning with the spectrum analyzer on the uplink output (donor) port. Confirm that the RF coupled path is connected to the spectrum analyzer.

b) Spectrum analyzer settings:

- 1) Center frequency at the center of the band under test
- 2) Span equal or slightly exceeding the width of the band under test
- 3) Continuous sweep, max-hold
- 4) RBW=1 MHz, VBW > 3RBW

c) Decrease the variable attenuator until the spectrum analyzer displays a signal within the band under test. Using a marker, identify the approximate center frequency of this signal on the max-hold display, increase the attenuation by 10 dB, then reset the EUT (e.g., cycle ac/dc power).

- d) Repeat c) twice to ensure that the center of the signal created by the booster remains within 250 kHz of the spectrum analyzer display center frequency. If the frequency of the signal is unstable, confirm that the spectrum analyzer display is centered between the frequency extremes observed. If the signal is wider than 1 MHz, ensure that the spectrum analyzer display is centered on the signal by increasing the RBW. Reset the EUT (e.g., cycle ac/dc power) after each oscillation event, if necessary. Set the spectrum analyzer sweep trigger level to just below the peak amplitude of the displayed EUT oscillation signal.
- e) Set the spectrum analyzer to zero-span, with a sweep time of 5 seconds, and single-sweep with max-hold. The spectrum analyzer sweep trigger level in this and the subsequent steps shall be the level identified in d).
- f) Decrease the variable attenuator until the spectrum analyzer sweep is triggered, increase the attenuation by 10 dB, then reset the EUT (e.g., cycle ac/dc power).
- g) Reset the zero-span trigger of the spectrum analyzer, then repeat f) twice to ensure that the spectrum analyzer is reliably triggered, resetting the EUT (e.g., cycle ac/dc power) after each oscillation event if necessary.
- h) Reset the zero-span sweep trigger of the spectrum analyzer, and reset the EUT (e.g., cycle ac/dc power).
- i) Force the EUT into oscillation by reducing the attenuation.
- j) Use the marker function of the spectrum analyzer to measure the time from the onset of oscillation until the EUT turns off, by setting Marker 1 on the leading edge of the oscillation signal and Marker 2 on the trailing edge. The spectrum analyzer sweep time may be adjusted to improve the time resolution of these cursors.
- k) Capture the spectrum analyzer zero-span trace for inclusion in the test report. Report the power level associated with the oscillation separately if it can't be displayed on the trace.
- l) Repeat b) to k) for all operational uplink and downlink bands.
- m) Set the spectrum analyzer zero-span sweep time for longer than 60 seconds, then measure the restart time for each operational uplink and downlink band.
- n) Replace the normal-operating mode EUT with the EUT that supports an anti-oscillation test mode.
- o) Set the spectrum analyzer zero-span time for a minimum of 120 seconds, and a single sweep.
- p) Manually trigger the spectrum analyzer zero-span sweep, and manually force the booster into oscillation as described in i).
- q) When the sweep is complete, place cursors between the first two oscillation detections, and save the plot for inclusion in the test report. The time between restarts must match the manufacturer's timing for the test mode, and there shall be no more than 5 restarts.
- r) Repeat m) to q) for all operational uplink and downlink bands.

12.4 Test Protocol

Temperature : 25 °C
Relative Humidity : 55 %

Detection Time				
Mode	Band (MHz)	Measured Time (ms)	Limit (ms)	Margin (ms)
Uplink	1710-1755	29	300	271.00
Uplink	824-849	61	300	239.00
Uplink	776-787	64	300	236.00
Uplink	704-716	16	300	284.00
Uplink	1850-1910	29	300	271.00
Downlink	2110-2155	141	1000	859.00
Downlink	869-894	119	1000	881.00
Downlink	746-757	31	1000	969.00
Downlink	734-746	29	1000	971.00
Downlink	1930-1990	28	1000	972.00

Uplink, 1710-1755MHz

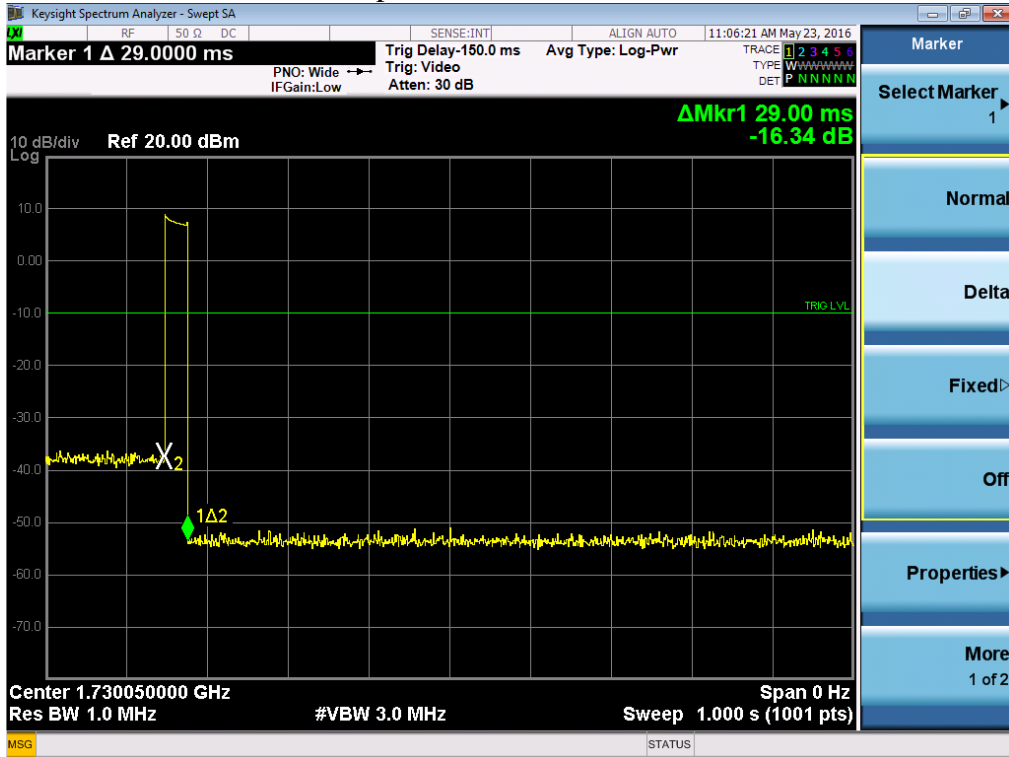

Uplink, 824-849MHz

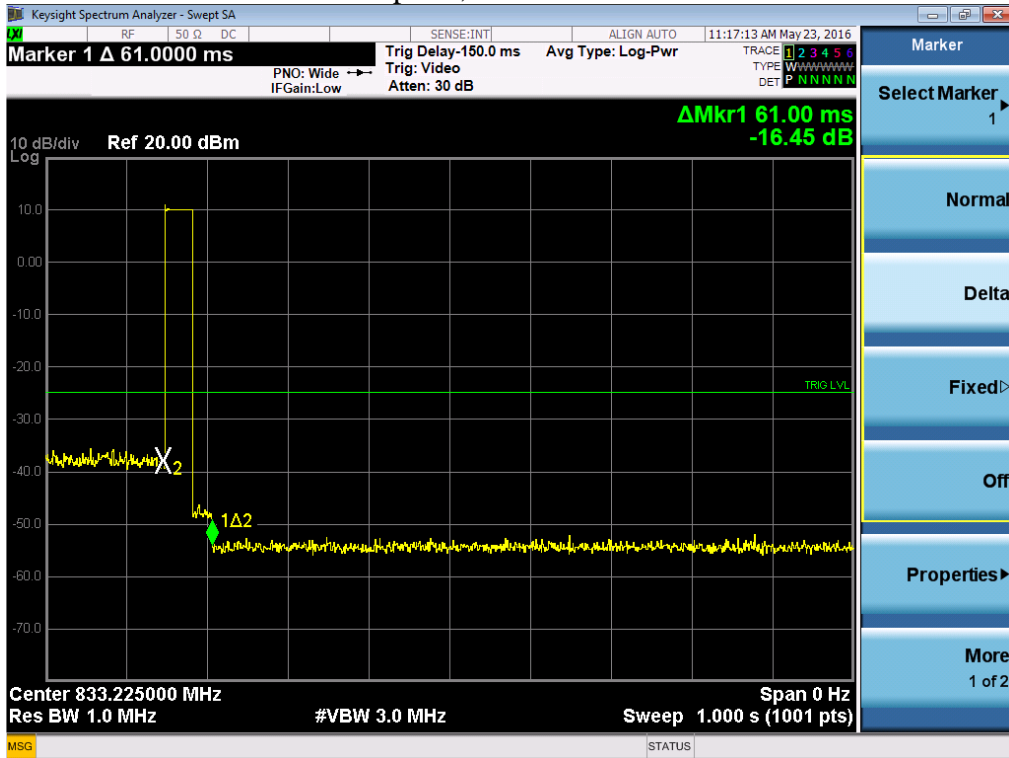

Uplink, 776-787MHz

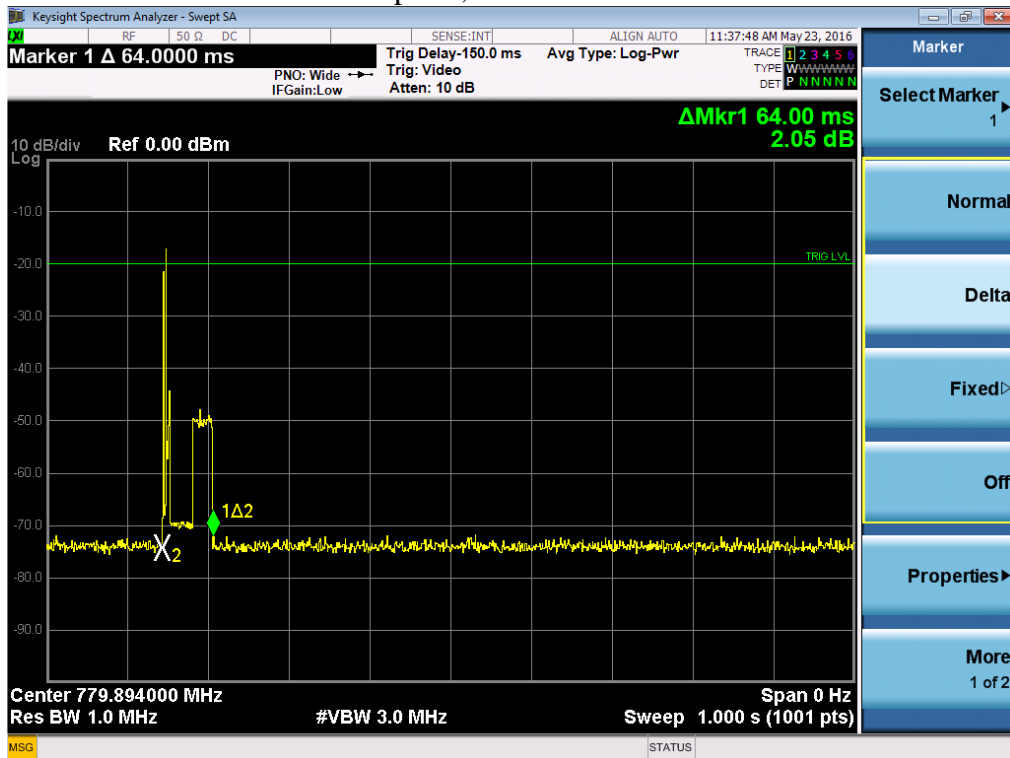

Uplink, 704-716MHz

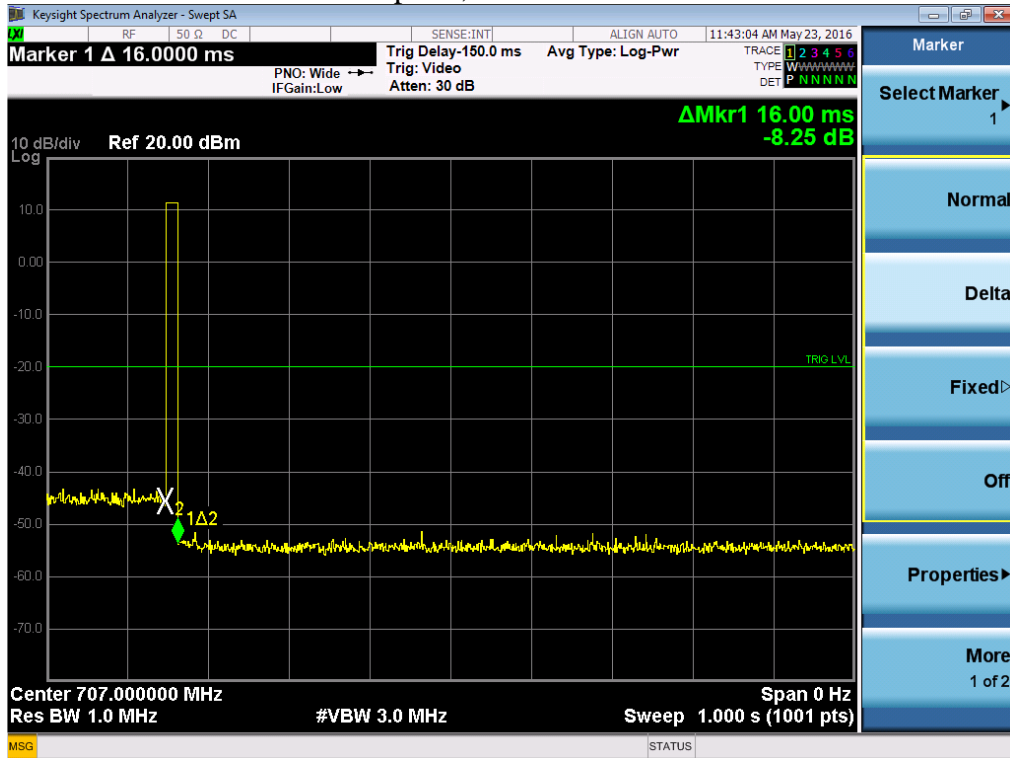

Uplink, 1850-1910MHz

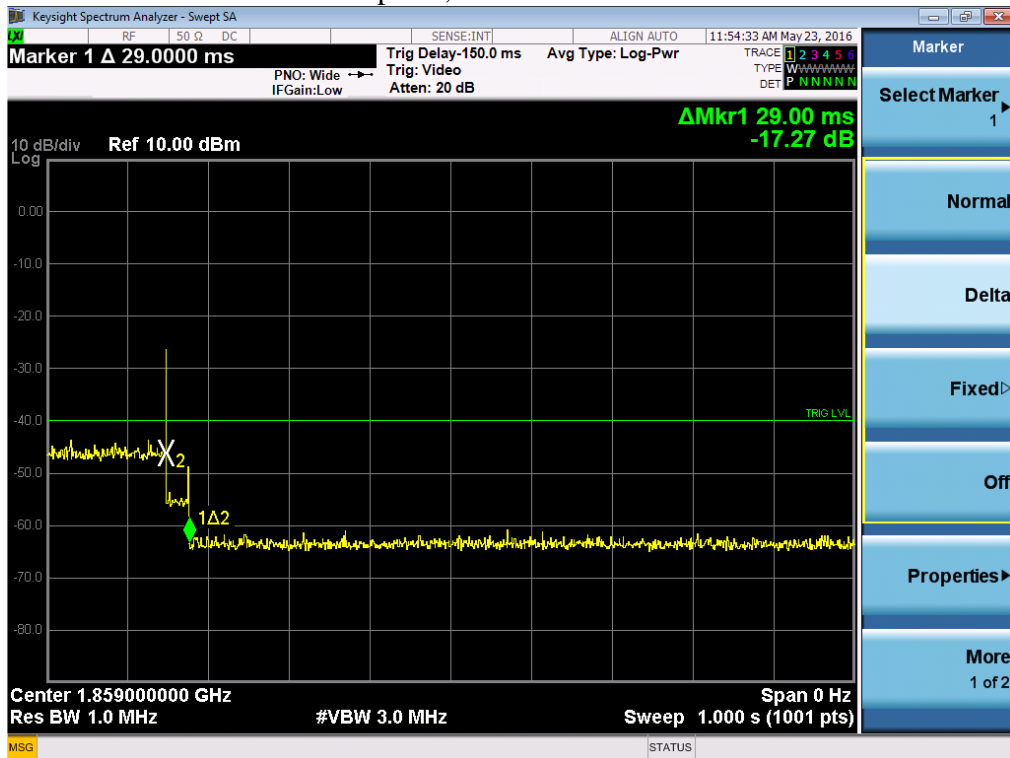

Downlink, 2110-2155MHz

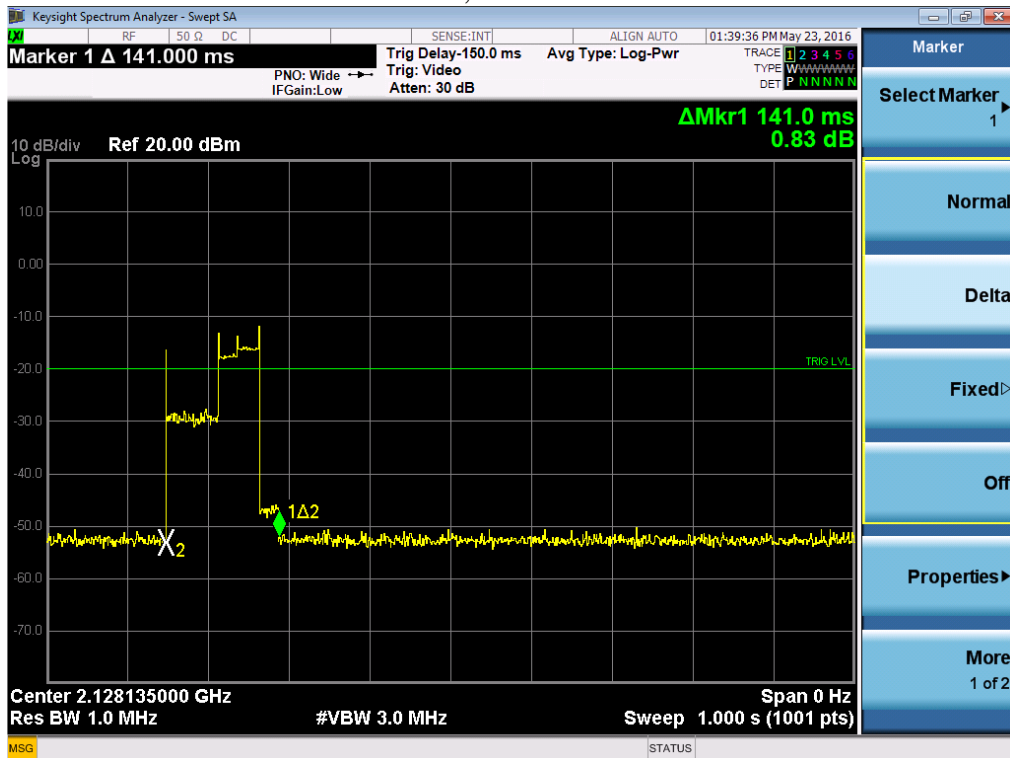

Downlink, 869-894MHz

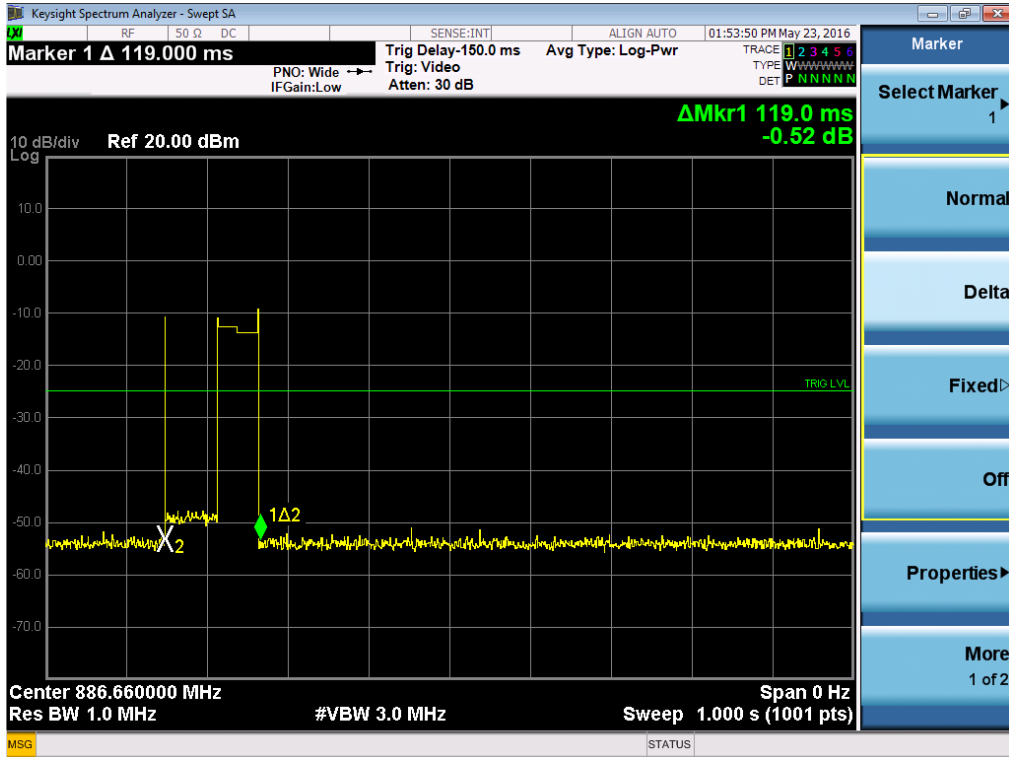

Downlink, 746-757MHz

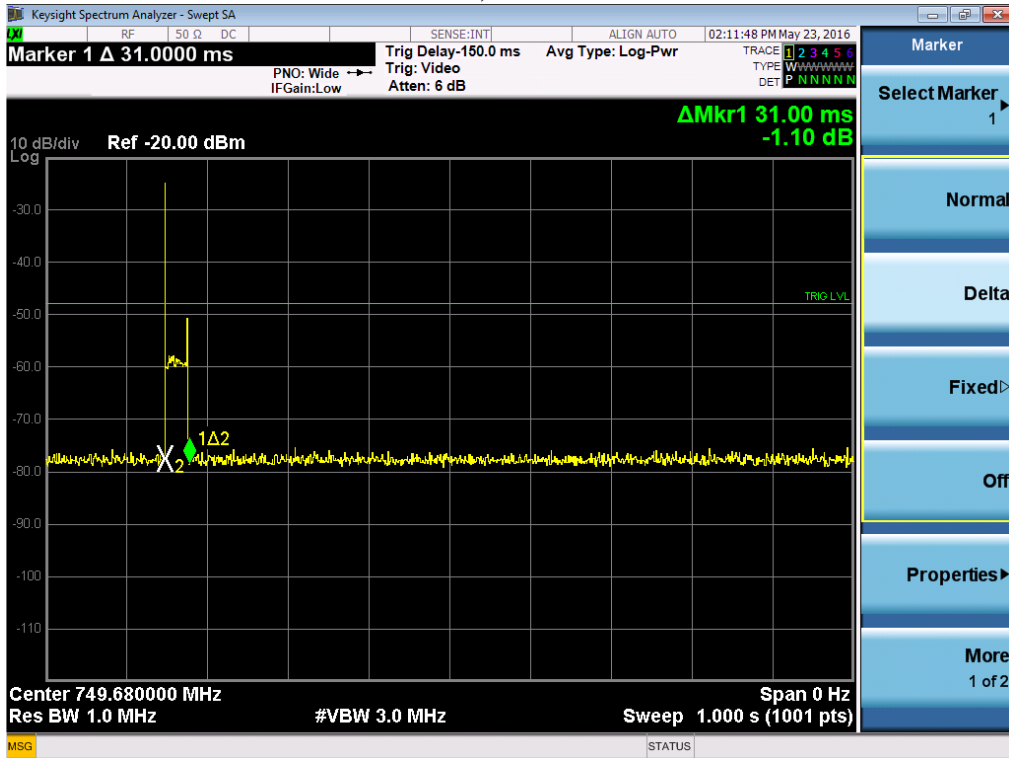

Downlink, 734-746MHz

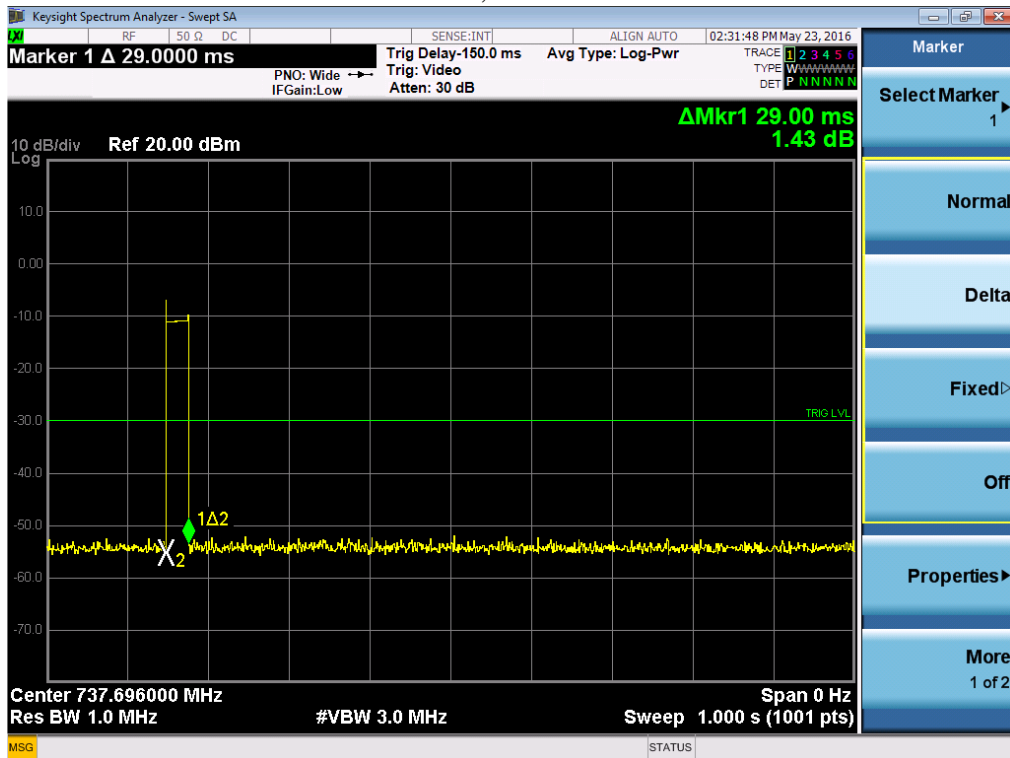

Downlink, 1930-1990MHz

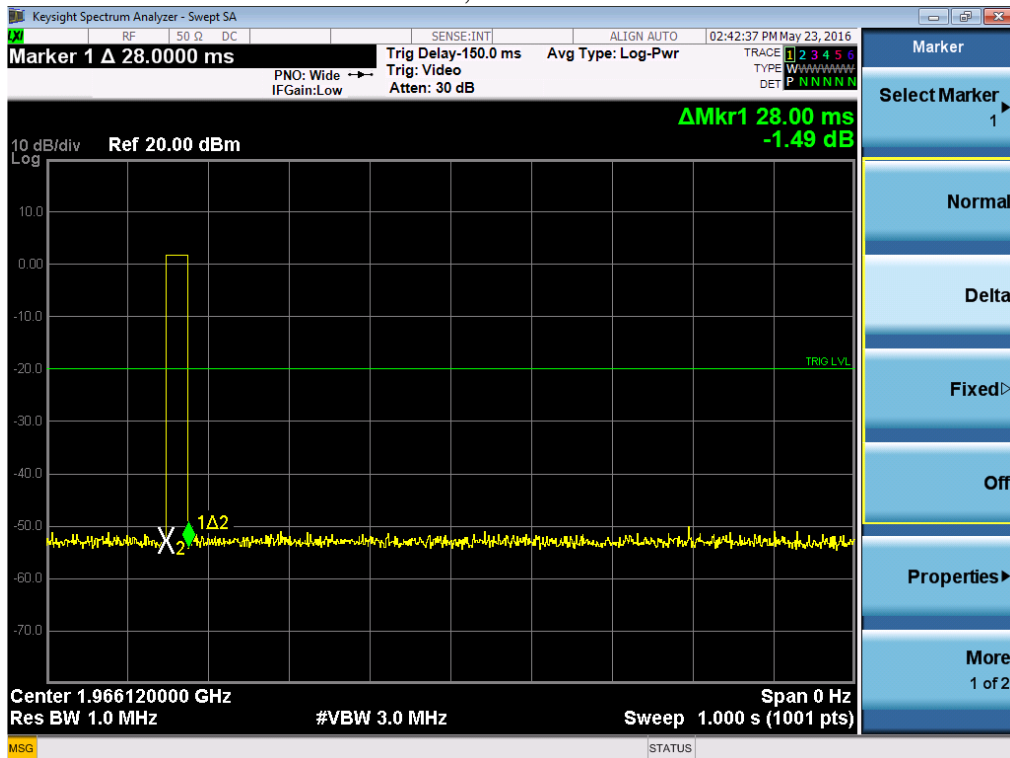

Restart Time				
Mode	Band (MHz)	Measured Time (s)	Limit (s)	Margin (s)
Uplink	1710-1755	70	≥60	10
Uplink	824-849	70	≥60	10
Uplink	776-787	69.65	≥60	9.65
Uplink	704-716	70	≥60	10
Uplink	1850-1910	70	≥60	10
Downlink	2110-2155	69.65	≥60	9.65
Downlink	869-894	70	≥60	10
Downlink	746-757	69.65	≥60	9.65
Downlink	734-746	69.65	≥60	9.65
Downlink	1930-1990	69.65	≥60	9.65

Restart Count				
Mode	Band (MHz)	Restarts	Limit	Margin
Uplink	1710-1755	4	≤5	1
Uplink	824-849	4	≤5	1
Uplink	776-787	4	≤5	1
Uplink	704-716	4	≤5	1
Uplink	1850-1910	4	≤5	1
Downlink	2110-2155	4	≤5	1
Downlink	869-894	4	≤5	1
Downlink	746-757	4	≤5	1
Downlink	734-746	4	≤5	1
Downlink	1930-1990	4	≤5	1

Uplink, 1710-1755MHz

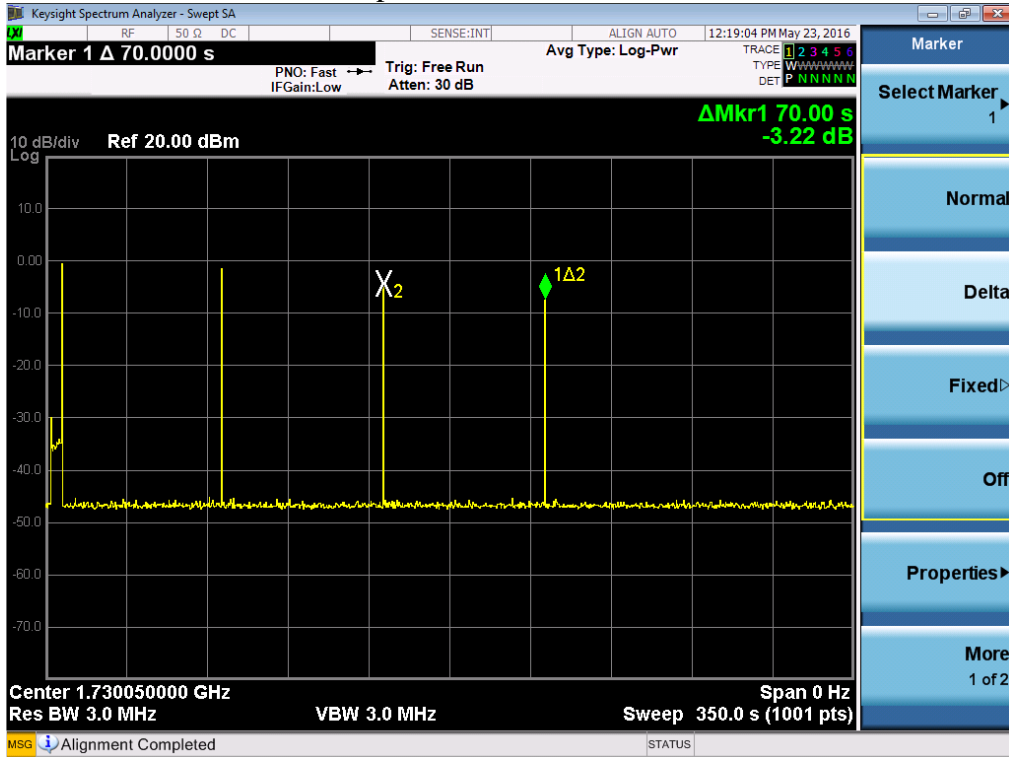

Uplink, 824-849MHz

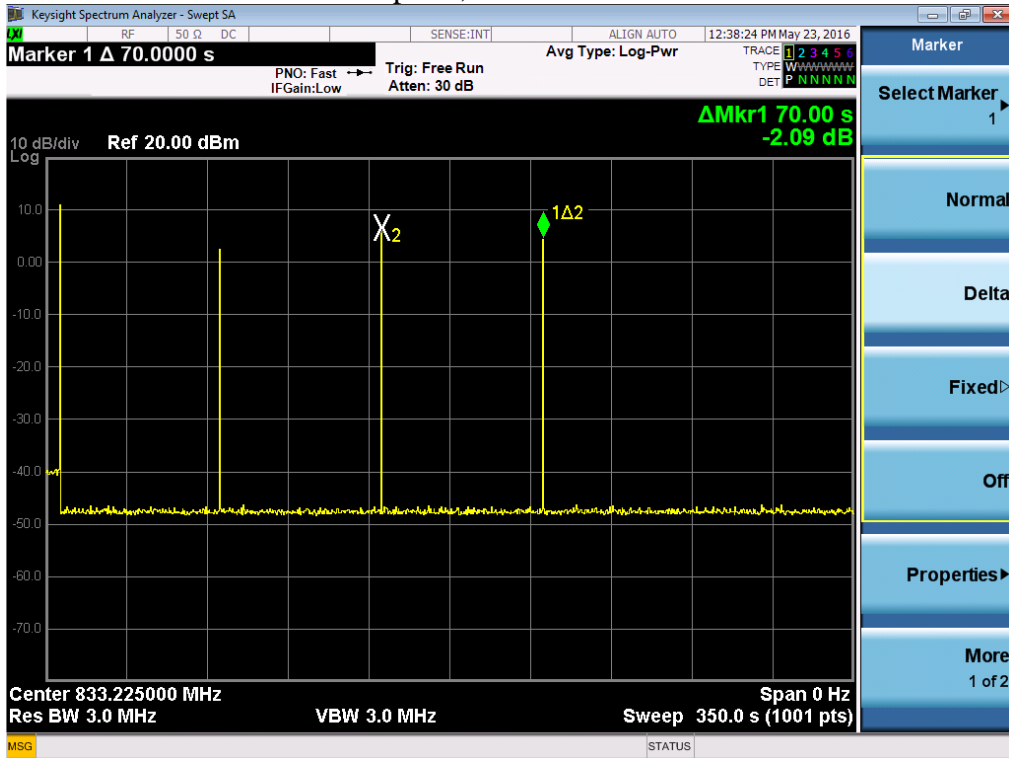

Uplink, 1850-1910MHz

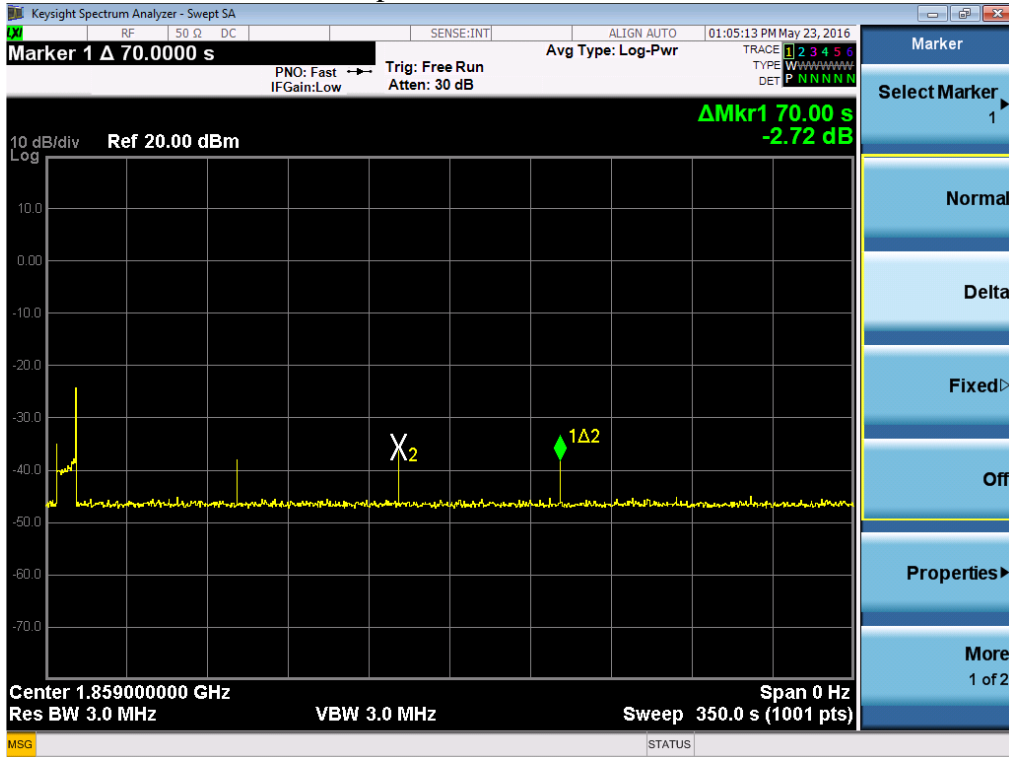

Downlink, 2110-2155MHz

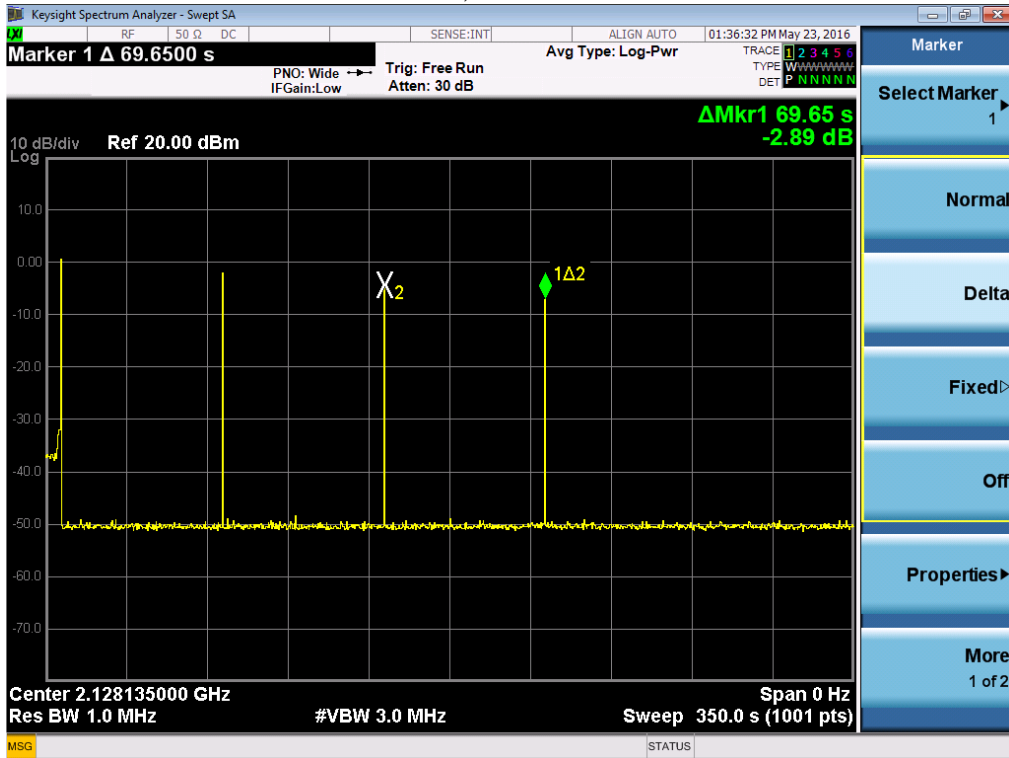

Downlink, 869-894MHz

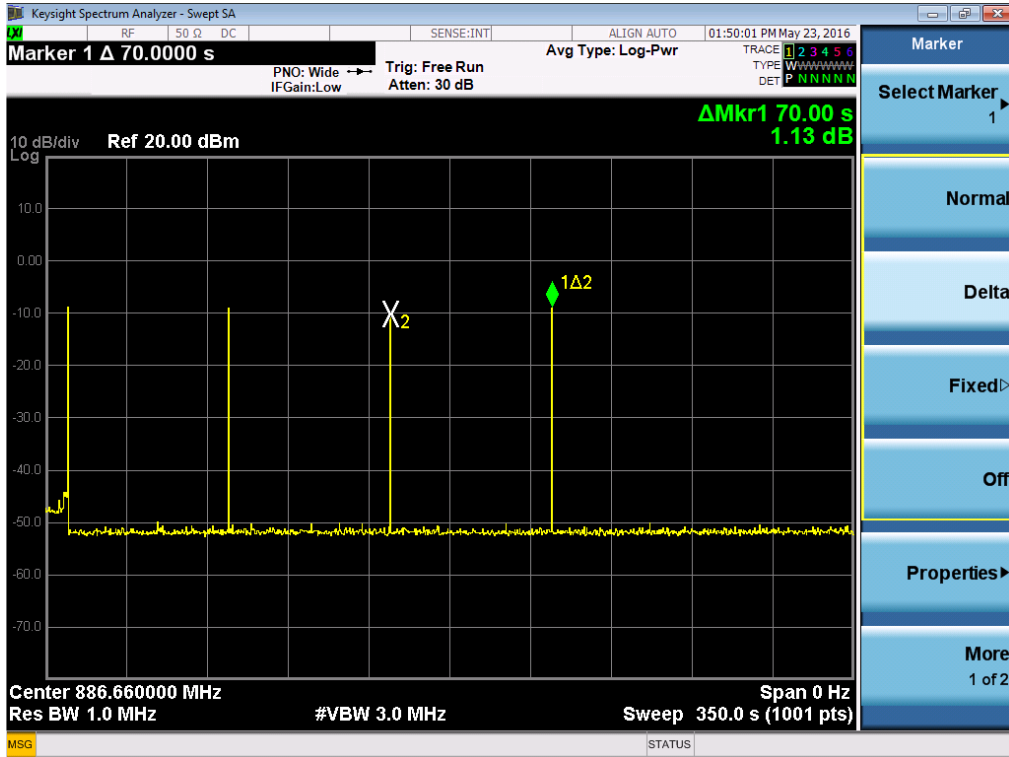

Downlink, 746-757MHz

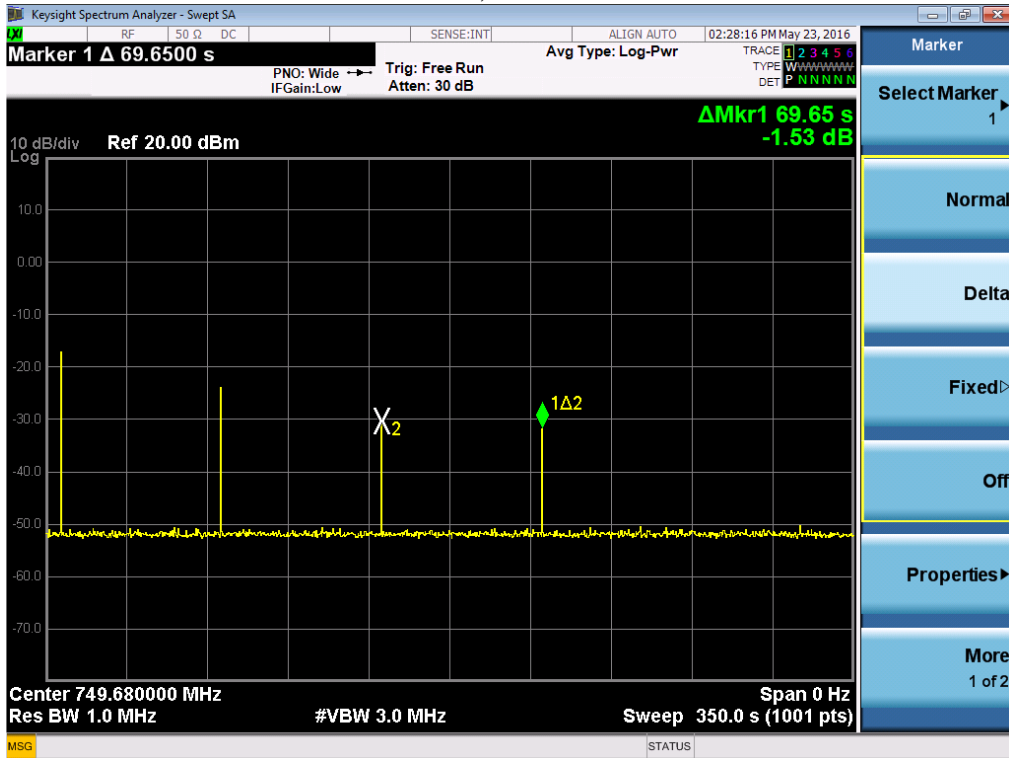

Downlink, 734-746MHz

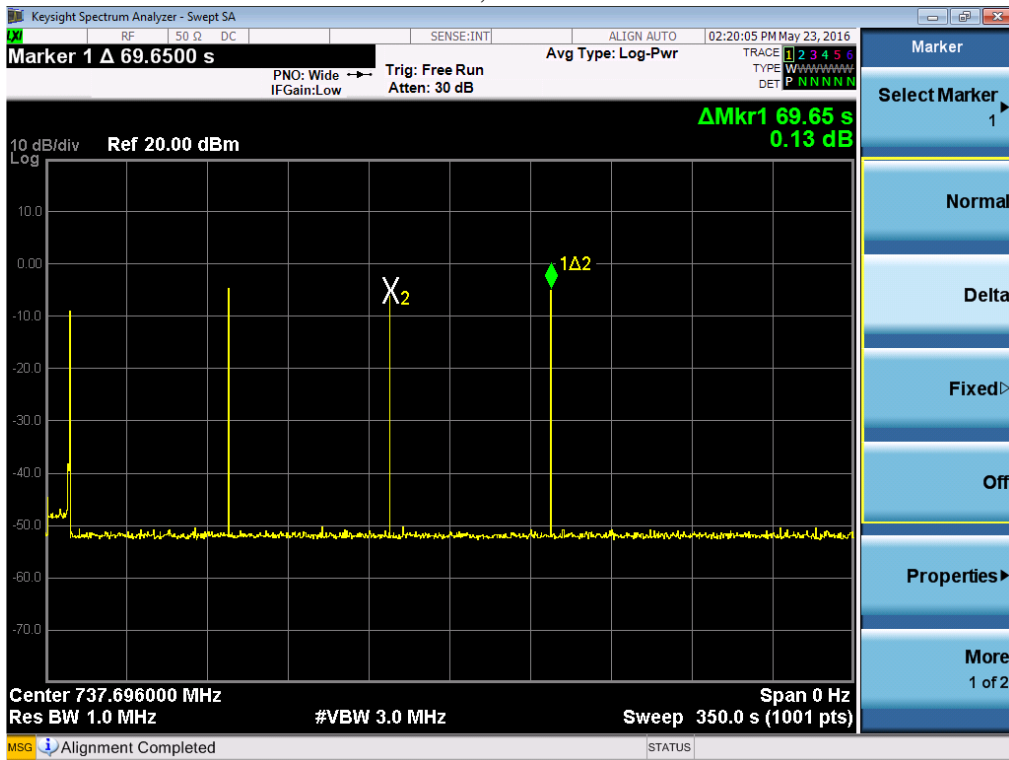

Downlink, 1930-1990MHz

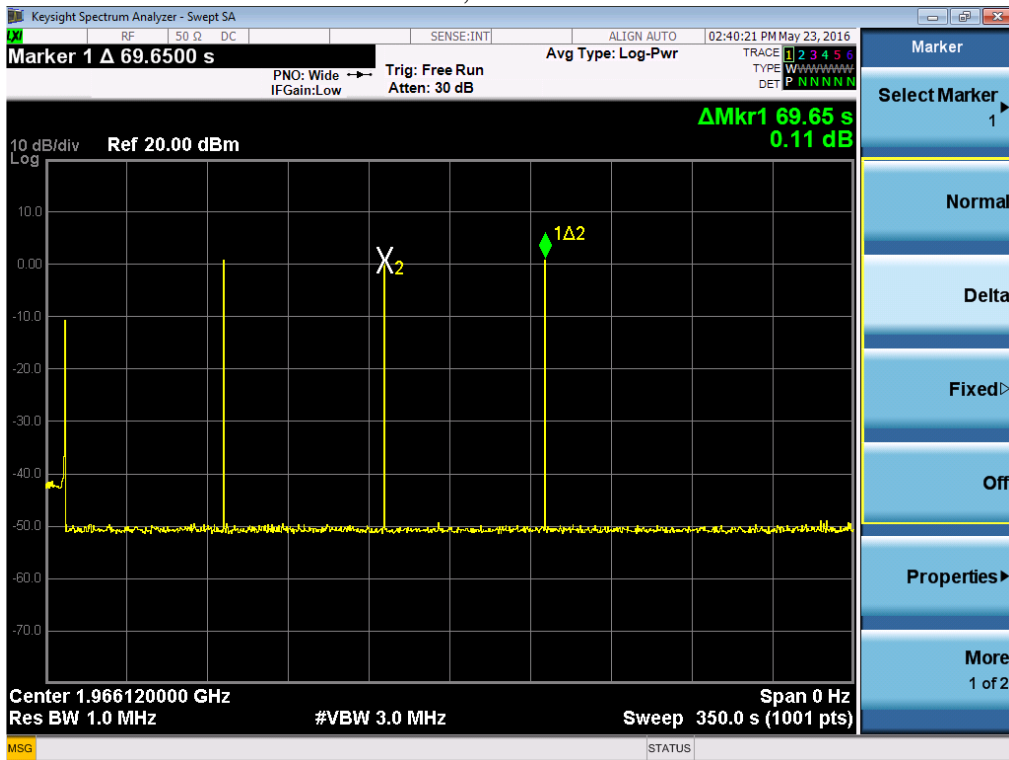

13. Oscillation Mitigation

Test result: Pass

13.1 Test limit

For oscillations that exceeded the 12 dB limit, the time required for the booster to mitigate the oscillation to less than 12dB was recorded.

If the booster mitigated the oscillation within the 300s time limit, the time required to mitigate the oscillation was recorded along with the final level of the oscillation after mitigation.

13.2 Test Configuration

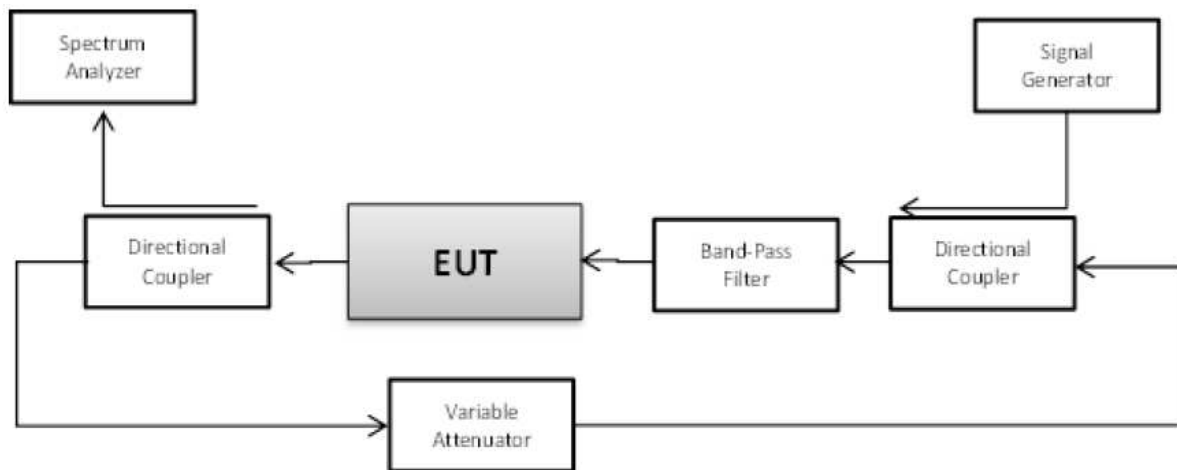

13.3 Test procedure and test setup

- a) Connect the normal-operating mode EUT to the test equipment as shown.
- b) Set the spectrum analyzer center frequency to the center of band under test, and use the following settings:
 - 1) $RBW=30\text{ kHz}$, $VBW \geq 3 \times RBW$,
 - 2) power averaging (rms) detector,
 - 3) trace averages ≥ 100 ,
 - 4) span $\geq 120\%$ of operational band under test,
 - 5) number of sweep points $\geq 2 \times \text{Span}/RBW$.
- c) Configure the signal generator for AWGN operation with a 99% OBW of 4.1 MHz, tuned to the frequency of 2.5 MHz above the lower edge or below the upper edge of the operating band under test. Adjust the RF output level of the signal generator such that the measured power level of the AWGN signal at the output port of the booster is 30 dB less than the maximum power of the booster for the band under test. Affirm that the input signal is not

obstructing the measurement of the strongest oscillation peak in the band, and is not included within the span in the measurement.

- 1) Boosters with operating spectrum passbands of 10 MHz or less may use a CW signal source at the band edge rather than AWGN.
- 2) For device passbands greater than 10 MHz, standard CMRS signal sources (i.e., CDMA, W-CDMA, LTE) may be used instead of AWGN at the band edge.
- d) Set the variable attenuator to a high attenuation setting such that the booster will operate at maximum gain when powered on. Reset the the EUT (e.g., cycle ac/dc power). Allow the EUT to complete its boot-up process, to reach full operational gain, and to stabilize its operation.
- e) Set the variable attenuator such that the insertion loss for the center of the band under test (isolation) between the booster donor port and server port is 5 dB greater than the maximum gain, as recorded in the maximum gain test procedure, for the band under test.
- f) Verify the EUT shuts down, i.e., to mitigate the oscillations. If the booster does not shut down, measure and verify the peak oscillation level as follows.
 - 1) Allow the spectrum analyzer trace to stabilize.
 - 2) Place the marker at the highest oscillation level occurring within the span, and record its output level and frequency.
 - 3) Set the spectrum analyzer center frequency to the frequency with the highest oscillation signal level, and reduce the span such that the upper and lower adjacent oscillation peaks are within the span.
 - 4) Use the Minimum Search Marker function to find the lowest output level that is within the span, and within the operational band under test, and record its output level and frequency.
 - 5) Affirm that the peak oscillation level measured in f2), does not exceed by 12.0 dB the minimal output level measured in f4). Record the measurement results of f2) and f4) in tabular format for inclusion in the test report.
 - 6) The procedure of f1) to f5) allows the spectrum analyzer trace to stabilize, and verification of shutdown or oscillation level measurement must occur within 300s.
- g) Decrease the variable attenuator in 1 dB steps, and repeat step f) for each 1 dB step. Continue testing to the level when the insertion loss for the center of band under test (isolation) between the booster donor port and server port is 5 dB lower than the maximum gain.
- h) Repeat a) to g) for all operational uplink and downlink bands.

13.4 Test Protocol

Temperature : 25 °C
Relative Humidity : 55 %

Signal type	Mode	Band (MHz)	Variable Attenuator (dB)	Time to shutdown (s)	Shutdown Limit (s)	Oscillation difference (dB)	Oscillation Limit (dB)
LTE	Uplink	1710-1755	+5	27	300	/	/
			+4	/	/	/	/
			+3	/	/	/	/
			+2	/	/	/	/
			+1	/	/	/	/
		824-849	+5	10	300	/	/
			+4	/	/	/	/
			+3	/	/	/	/
			+2	/	/	/	/
			+1	/	/	/	/
		776-787	+5	35	300	/	/
			+4	/	/	/	/
			+3	/	/	/	/
			+2	/	/	/	/
			+1	/	/	/	/
		704-716	+5	33	300	/	/
			+4	/	/	/	/
			+3	/	/	/	/
			+2	/	/	/	/
			+1	/	/	/	/
	1850-1910	+5	11	300	/	/	
		+4	/	/	/	/	
		+3	/	/	/	/	
		+2	/	/	/	/	
		+1	/	/	/	/	
	Downlink	2110-2155	+5	12	300	/	/
			+4	/	/	/	/
			+3	/	/	/	/
			+2	/	/	/	/
			+1	/	/	/	/
		869-894	+5	12	300	/	/
			+4	/	/	/	/
			+3	/	/	/	/
			+2	/	/	/	/
			+1	/	/	/	/
		746-757	+5	36	300	/	/
+4			/	/	/	/	
+3			/	/	/	/	
+2			/	/	/	/	
+1			/	/	/	/	



		734-746	+5	28	300	/	/
			+4	/	/	/	/
			+3	/	/	/	/
			+2	/	/	/	/
			+1	/	/	/	/
		1930-1990	+5	31	300	/	/
			+4	/	/	/	/
			+3	/	/	/	/
			+2	/	/	/	/
			+1	/	/	/	/

14. Radiated Spurious Emission

Test result: PASS

14.1 Test limit

Radiated Spurious Emissions Limit = $P1 - (43 + 10\text{Log}(P2)) = -13\text{dBm}$

P1 = power in dBm

P2 = power in Watts

14.2 Test Configuration

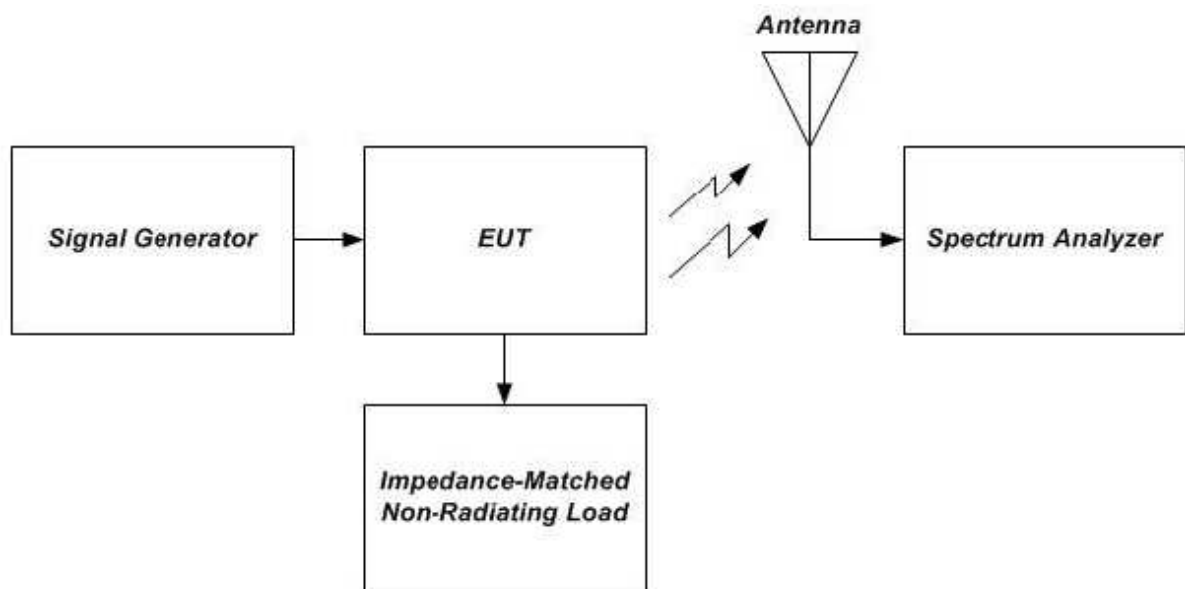

14.3 Test procedure and test setup

- a) Place the EUT on an OATS or semi-anechoic chamber turntable 3 m from the receiving antenna.
- b) Connect the EUT to the test equipment as shown beginning with the uplink output (donor) port.
- c) Set the signal generator to produce a CW signal with the frequency set to the center of the operational band under test, and the power level set at PIN as determined from measurement results.
- d) Measure the radiated spurious emissions from the EUT from the lowest to the highest frequencies as specified in § 2.1057. Maximize the radiated emissions by using the procedures described in ANSI C63.4.
- e) Capture the peak emissions plots using a peak detector with Max-Hold for inclusion in the test report. Tabular data is acceptable in lieu of spectrum analyzer plots.
- f) Repeat c) through e) for all uplink and downlink operational bands

The radiated emission was measured using the Spectrum Analyzer with the resolutions bandwidth set as:

RBW = 300 Hz, VBW = 1 kHz (9 kHz~150 kHz);
RBW = 10 kHz, VBW = 30 kHz (150 kHz~30MHz);
RBW = 100 kHz, VBW = 300 kHz (30MHz~1GHz for PK)

14.4 Test protocol

Temperature: 25 °C

Relative Humidity: 55 %

Mode	Band (MHz)	Polar (H/V)	Freq. (MHz)	Receiver reading (dBμV)	Substituted Method		Substituted reading (dBm)	Limit (dBm)
					SG (dBm)	Factor (dBi)		
Uplink	1710-1755	H	119.41	35.30	-66.10	1.40	-64.70	-13
		H	992.22	40.40	-65.70	6.10	-59.60	
		V	1732.50	56.70	-42.10	8.80	-33.30	
		V	3464.90	42.90	-56.90	9.80	-47.10	
	824-849	H	119.41	37.70	-63.70	1.40	-62.30	
		V	836.71	61.40	-43.90	5.30	-38.60	
		V	1667.33	26.60	-71.80	8.40	-63.40	
		V	2154.30	26.90	-72.80	9.70	-63.10	
	776-787	H	119.41	37.80	-63.60	1.40	-62.20	
		H	781.34	65.60	-40.74	6.34	-34.40	
		V	1559.11	36.60	-62.20	8.80	-53.40	
		V	6248.49	38.70	-59.50	8.20	-51.30	
	704-716	H	119.41	35.60	-65.80	1.40	-64.40	
		H	710.36	65.20	-41.10	6.30	-34.80	
		V	1414.82	55.20	-63.70	7.80	-55.90	
		V	6771.54	34.10	-63.50	8.20	-55.30	
	1850-1910	H	119.41	35.80	-65.60	1.40	-64.20	
		H	992.22	40.90	-65.20	6.10	-59.10	
		V	1880.76	61.00	-38.10	9.10	-29.00	
		V	3759.51	33.20	-66.60	9.80	-56.80	
Downlink	2110-2155	H	119.41	34.80	-66.60	1.40	-65.20	
		H	883.36	46.50	-58.80	5.30	-53.50	
		V	2132.27	44.00	-55.70	9.70	-46.00	
		V	6591.18	34.70	-63.50	8.20	-55.30	
	869-894	H	119.41	34.70	-66.70	1.40	-65.30	
		H	881.52	46.30	-59.00	5.30	-53.70	
		V	2154.30	28.30	-71.40	9.70	-61.70	
	746-757	H	119.41	34.90	-66.50	1.40	-65.10	
		H	751.56	45.70	-60.64	6.34	-54.30	
		V	2254.30	27.70	-72.00	9.70	-62.30	
	734-746	H	119.41	34.60	-66.80	1.40	-65.40	
		H	740.37	45.50	-60.80	6.30	-54.50	
		V	2223.45	27.10	-72.70	9.80	-62.90	
	1930-1990	H	119.41	34.80	-66.60	1.40	-65.20	
H		992.22	40.90	-65.20	6.10	-59.10		
V		1955.91	47.70	-51.80	9.50	-42.30		

Note: 1. Factor= Substituted Antenna gain - Cable Loss;
2. 'SG' means reading of signal generator among the Substituted system;
3. Substituted reading = SG + Factor;

15. Occupied bandwidth

Test Status: Pass

15.1 Test limit

For each modulation type, the input and output signal was measured and plotted to ensure that the signals were similar.

15.2 Test Configuration

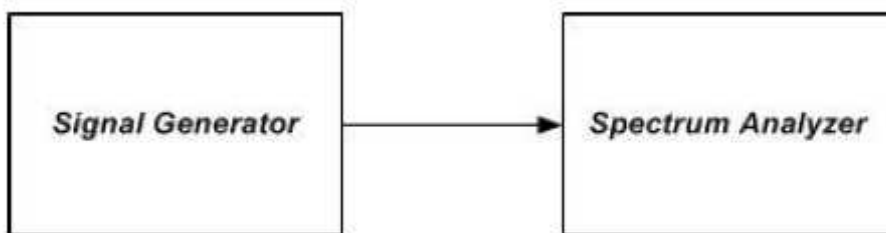

15.3 Test procedure and test setup

- a) Connect the test equipment as shown to firstly measure the characteristics of the test signals produced by the signal generator.
- b) Set $VBW \geq 3 * RBW$.
- c) Set the center frequency of the spectrum analyzer to the center of the operational band. The span will be adjusted for each modulation type and OBW as necessary for accurately viewing the signals
- d) Set the signal generator for power level to match the values obtained from the test.
- e) Set the signal generator modulation type for GSM with a PRBS pattern and allow the trace on the signal generator to stabilize adjusting the span as necessary.
- f) Set the spectrum analyzer RBW for 1% to 5% of the EBW.
- g) Capture the spectrum analyzer trace for inclusion in the test report.
- h) Repeat c) to g) for CDMA and W-CDMA modulation, adjusting the span as necessary. AWGN or LTE may be used in place of W-CDMA, as an option.
- i) Repeat c) to h) for all uplink and downlink operational bands.
- j) Connect the test equipment as shown, with the uplink output (donor) port connected to the spectrum analyzer, and the server port connected to the signal generator.
- k) Repeat c) to i) with this EUT uplink path test setup.
- l) Connect the test equipment as shown, with the downlink output (server) port connected to the spectrum analyzer, and the donor port connected to the signal generator.
- m) Repeat c) to i) with this EUT downlink path test setup.