

## FCC TEST REPORT for Broadband Consumer Booster No. 160400140SHA-001

Applicant : WUHAN GEWEI ELECTRONIC TECHNOLOGIES CO., LTD.  
No.2 Bldg., NO.3 Area, Guandong Science & Technology  
Industry Zone, Hongshan District, Wuhan, Hubei, China

Manufacturer : WUHAN GEWEI ELECTRONIC TECHNOLOGIES CO., LTD.  
No.2 Bldg., NO.3 Area, Guandong Science & Technology  
Industry Zone, Hongshan District, Wuhan, Hubei, China

Product Name : Signal Booster  
Type/Model : PR-U-C

**TEST RESULT : PASS**

### SUMMARY

The equipment complies with the requirements according to the following standard(s):

**47CFR Part 20.21 (2015):** COMMERCIAL MOBILE SERVICES, Signal boosters

**ANSI/TIA 603-D (2010):** Land Mobile FM or PM Communications Equipment  
Measurement and Performance Standards

**KDB 935210 D03 Signal Booster Measurements v04:** PROVIDER-SPECIFIC  
CONSUMER SIGNAL BOOSTERS COMPLIANCE MEASUREMENTS GUIDANCE

Date of issue: July 14, 2016

Prepared by:

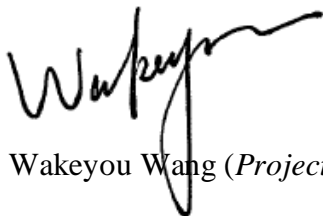

Wakeyou Wang (*Project Engineer*)

Reviewed by:

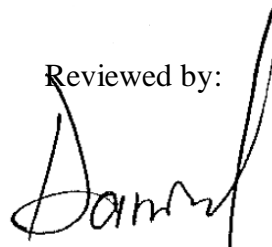

Daniel Zhao (*Reviewer*)



## Description of Test Facility

Name: Intertek Testing Services Limited Shanghai  
Address: Building 86, No. 1198 Qinzhou Rd., North, Shanghai 200233, P.R. China

FCC Registration Number: 236597  
IC Assigned Code: 2042B-1

Name of contact: Jonny Jing  
Tel: +86 21 61278271  
Fax: +86 21 54262353

## Content

<b>SUMMARY .....</b>	<b>1</b>
<b>DESCRIPTION OF TEST FACILITY .....</b>	<b>2</b>
<b>1. GENERAL INFORMATION.....</b>	<b>5</b>
1.1 Applicant Information .....	5
1.2 Identification of the EUT.....	5
1.3 Technical specification .....	6
<b>2. TEST SPECIFICATIONS .....</b>	<b>7</b>
2.1 Test Standard.....	7
2.2 Mode of operation during the test.....	7
2.3 Test software list .....	7
2.4 Test peripherals list .....	7
2.5 Instrument list.....	8
<b>3. AUTHORIZED FREQUENCY BAND VERIFICATION.....</b>	<b>11</b>
3.1 Test limit.....	11
3.2 Test Configuration .....	11
3.3 Test procedure and test setup .....	12
3.4 Test protocol.....	13
<b>4. MAXIMUM POWER.....</b>	<b>18</b>
4.1 Test limit.....	18
4.2 Test Configuration .....	18
4.3 Test procedure and test setup .....	19
4.4 Test Protocol .....	20
<b>5. MAXIMUM BOOSTER GAIN COMPUTATION .....</b>	<b>21</b>
5.1 Test limit.....	21
5.2 Test Configuration .....	21
5.3 Test procedure and test setup .....	22
5.4 Test Protocol .....	23
<b>6. INTER-MODULATION .....</b>	<b>24</b>
6.1 Test limit.....	24
6.2 Test Configuration .....	24
6.3 Test procedure and test setup .....	25
6.4 Test Protocol .....	26
<b>7. OUT-OF-BAND EMISSIONS .....</b>	<b>32</b>
7.1 Test limit.....	32
7.2 Test Configuration .....	32
7.3 Test procedure and test setup .....	33
7.4 Test Protocol .....	34
<b>8. CONDUCTED SPURIOUS EMISSIONS.....</b>	<b>67</b>
8.1 Test limit.....	67
8.2 Test Configuration .....	67
8.3 Test procedure and test setup .....	68
8.4 Test Protocol .....	69
<b>9. NOISE LIMITS .....</b>	<b>77</b>
9.1 Test limit.....	77
9.2 Test Configuration .....	77

9.3 Test procedure and test setup .....	78
9.4 Test Protocol .....	80
<b>10. UPLINK INACTIVITY .....</b>	<b>91</b>
10.1 Test limit.....	91
10.2 Test Configuration .....	91
10.3 Test procedure and test setup.....	91
10.4 Test Protocol .....	92
<b>11. VARIABLE BOOSTER GAIN .....</b>	<b>95</b>
11.1 Test limit.....	95
11.2 Test Configuration .....	95
11.3 Test procedure and test setup.....	96
11.4 Test Protocol .....	97
<b>12. OSCILLATION DETECTION .....</b>	<b>99</b>
12.1 Test limit.....	99
12.2 Test Configuration .....	99
12.3 Test procedure and test setup.....	99
12.4 Test Protocol .....	101
<b>13. OSCILLATION MITIGATION.....</b>	<b>113</b>
13.1 Test limit.....	113
13.2 Test Configuration .....	113
13.3 Test procedure and test setup.....	113
13.4 Test Protocol .....	115
<b>14. RADIATED SPURIOUS EMISSION .....</b>	<b>117</b>
14.1 Test limit.....	117
14.2 Test Configuration .....	117
14.3 Test procedure and test setup.....	118
14.4 Test protocol.....	119
<b>15. OCCUPIED BANDWIDTH .....</b>	<b>120</b>
15.1 Test limit.....	120
15.2 Test Configuration .....	120
15.3 Test procedure and test setup.....	120
15.4 Test protocol.....	121

## 1. General Information

### 1.1 Applicant Information

Applicant : WUHAN GEWEI ELECTRONIC TECHNOLOGIES CO., LTD.  
No.2 Bldg., NO.3 Area, Guandong Science & Technology  
Industry Zone, Hongshan District, Wuhan, Hubei, China

Name of contact : Yaoguang He

Tel : +86-27-59619018

Fax : +86-27-59101661

Manufacturer : WUHAN GEWEI ELECTRONIC TECHNOLOGIES CO., LTD.  
No.2 Bldg., NO.3 Area, Guandong Science & Technology  
Industry Zone, Hongshan District, Wuhan, Hubei, China

Sample received date : April 5, 2016

Date of test : April 5, 2016 ~ June 7, 2016

### 1.2 Identification of the EUT

Equipment : Signal Booster

Type/model : PR-U-C

S/N : /

FCC ID : 2AIMOPR-U-C

IC : /

### 1.3 Technical specification

Operation Frequency Band:

LTE Band	4	5	13	17	25
Uplink	1710 - 1755	824 - 849	776 - 787	704 - 716	1850 - 1910
Downlink	2110 - 2155	869 - 894	746 - 757	734 - 746	1930 - 1990
Modulation Type	CDMA, HSPA, LTE, EDGE, EVDO	GSM, CDMA, EDGE, HSPA, EVDO, LTE	LTE	LTE	GSM, CDMA, EDGE, HSPA, EVDO, LTE

Emission Designators:

CDMA	HSPA	LTE	EVDO	EDGE	GSM
F9W	F9W	G7D	F9W	G7W	GXW

Rating:

DC 5V powered by adapter:  
AC 100-240V, 0.35A, 50/60Hz; output DC 5V, 2A

Description of EUT:

The EUT is an In-Building bi-directional amplifier for the boosting of cellular phone signals and data communication devices.

Port identification:

Outside Antenna, Inside Antenna, Power

EUT type:

Ceiling mounted     Wall mounted  
 Table top     Floor standing

## 2. TEST SPECIFICATIONS

### 2.1 Test Standard

47CFR Part 20.21:2015  
ANSI/TIA 603-D (2010)  
KDB 935210 D03 Signal Booster Measurements v04

### 2.2 Mode of operation during the test

The final qualification test was performed with the EUT operating at normal mode.

### 2.3 Test software list

Test Items	Software	Manufacturer	Version
Conducted emission	ESxS-K1	R&S	V2.1.0
Radiated emission	ES-K1	R&S	V1.71

### 2.4 Test peripherals list

Instrument	Manufacturer	Type No.
Splitter/Combiner (Qty: 2)	Mini-Circuits	ZX10R-14-S+
Splitter/Combiner (Qty: 2)	Shanghai Huaxiang	SHX-GF2-2-6
ATT (Qty: 2)	Shanghai Huaxiang	SMAG-10dB-6G
ATT (Qty: 2)	Shanghai Huaxiang	SMAG-20dB-6G
ATT (Qty: 2)	Shanghai Huaxiang	SMAG2-30dB-18G
Laptop PC	HP	ProBook 6470b

## 2.5 Instrument list

Equipment	Type	Manu.	Internal no.	Cal. Date	Due date
Shielded room	-	Zhongyu	EC 2838	1/9/2016	1/8/2017
Test Receiver	ESCS 30	R&S	EC 2107	10/20/2015	10/19/2016
A.M.N.	ESH2-Z5	R&S	EC 3119	12/17/2015	12/16/2016
A.M.N.	ENV 216	R&S	EC 3394	8/2/2015	8/1/2016
A.M.N.	ENV4200	R&S	EC3558	8/2/2015	8/1/2016
Bilog Antenna	CBL 6112D	TESEQ	EC 4206	4/28/2016	4/27/2017
Ultra-broadband antenna	HL 562	R&S	EC 3046-1	12/18/2015	12/17/2016
Horn antenna	HF 906	R&S	EC 3049	4/28/2016	4/27/2017
Horn antenna	3117	ETS	EC 4792-1	4/22/2016	4/21/2017
Horn antenna	HAP18-26W	TOYO	EC 4792-3	6/12/2015	6/11/2016
Pre-amplifier	Pre-amp 18	R&S	EC 5262	5/26/2016	5/25/2017
Pre-amplifier	Tpa0118-40	TOYO	EC 4792-2	4/12/2015	4/11/2016
Fully-anechoic chamber	-	Albatross project	EC 3047	5/12/2016	5/11/2017
Signal generator	SMR 20	R&S	EC 3044-1	8/18/2015	8/17/2016
Power amplifier	150W1000	AR	EC 3044-2	8/15/2015	8/14/2016
Power amplifier	25S1G4	AR	EC 3044-4	8/15/2015	8/14/2016
Power sensor / Power meter	N1911A/N1921A	Agilent	EC4318	4/9/2016	4/8/2017
PXA Signal Analyzer	N9030A	Agilent	EC5338	5/15/2016	5/14/2017
Power sensor	U2021XA	Agilent	EC5338-1	3/6/2016	3/5/2017
Vector Signal Generator	N5182B	Agilent	EC5175	1/9/2016	1/8/2017
MXG Analog Signal Generator	N5181A	Agilent	EC5338-2	3/6/2016	3/5/2017
Mobile Test System	Iqxel	Litepoint	EC 5176	1/9/2016	1/8/2017
Spectrum analyzer	E7402A	Agilent	EC2254	8/15/2015	8/14/2016
DDC	DC 7144A	AR	EC 3044-6	1/9/2016	1/8/2017

## 2.6 Test Summary

**This report applies to tested sample only. The test results have been compared directly with the limits, and the measurement uncertainty is recorded. This report shall not be reproduced in part without written approval of Intertek Testing Service Shanghai Limited.**

TEST ITEM	FCC REFERANCE	RESULT
Authorized frequency band verification test	20.21(e)(3)	Pass
Maximum power	20.21(e)(8)(i)(D)	Pass
Maximum booster gain computation	20.21(e)(8)(i)(C)(2)	Pass
Inter-modulation	20.21(e)(8)(i)(F)	Pass
Out-of-band emissions	20.21(e)(8)(i)(E)	Pass
Conducted spurious emissions	2.1051; 22.917(a); 24.238(a) 27.53(c); 27.53(e); 27.53(f) 27.53(g)	Pass
Noise limits	20.21(e)(8)(i)(A)	Pass
Uplink inactivity	20.21(e)(8)(i)(I)	Pass
Variable booster gain	20.21(e)(8)(i)(C)(1)	Pass
Oscillation Detection	20.21(e)(8)(ii)(A) 20.21(e)(5)	Pass
Oscillation Mitigation	20.21(e)(8)(ii)(A) 20.21(e)(5)	Pass
Radiated Spurious Emission	2.1051	Pass

Occupied bandwidth	2.1049	Pass
Spectrum Block Filtering <i>(This only applies to devices utilizing spectrum block filtering)</i>	20.21(e)(8)(i)(B)	NA

Notes: 1: NA =Not Applicable

2: This report is for the exclusive use of Intertek's Client and is provided pursuant to the agreement between Intertek and its Client. Intertek's responsibility and liability are limited to the terms and conditions of the agreement. Intertek assumes no liability to any party, other than to the Client in accordance with the agreement, for any loss, expense or damage occasioned by the use of this report. Only the Client is authorized to permit copying or distribution of this report and then only in its entirety. Any use of the Intertek name or one of its marks for the sale or advertisement of the tested material, product or service must first be approved in writing by Intertek. The observations and test results in this report are relevant only to the sample tested. This report by itself does not imply that the material, product, or service is or has ever been under an Intertek certification program.

### 3. Authorized frequency band verification

Test result: Pass

#### 3.1 Test limit

None

#### 3.2 Test Configuration

Uplink test configuration

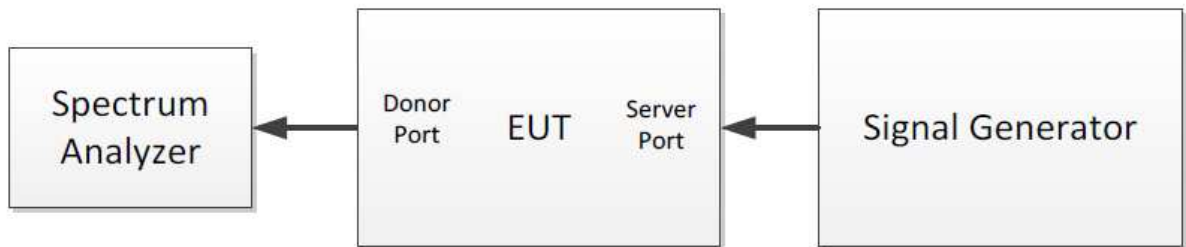

Downlink test configuration

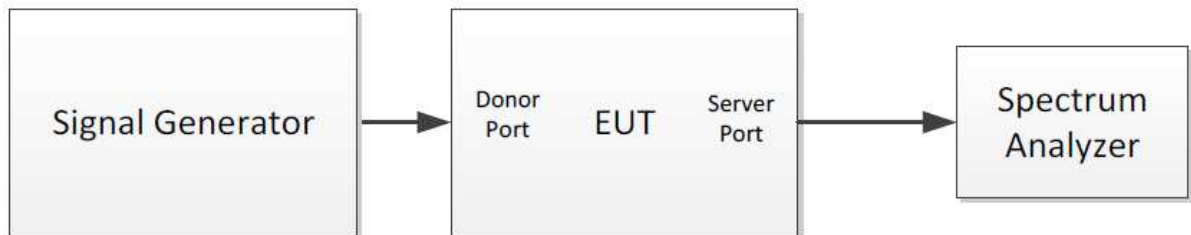

### 3.3 Test procedure and test setup

- a) Connect the EUT to the test equipment either in test mode or normal mode and set the passband of the EUT to the lowest passband frequency of the booster in the CMRS band.
- b) Set the spectrum analyzer resolution bandwidth (RBW) for 100 kHz with the video bandwidth (VBW)  $\geq 3 \times$  RBW, using a PEAK detector with the MAX HOLD function.
- c) Set the center frequency of the spectrum analyzer to the center of the operational band under test with a span of 5 MHz.
- d) Set the signal generator for CW mode and tune to the center frequency of the operational band under test. Alternatively, for signal boosters that implement narrowband rejection protection capability, a 200 kHz or an AWGN signal with a 99% occupied bandwidth (OBW) of 4.1 MHz can be used, as appropriate.
- e) Set the initial signal generator power to a level that is at least 6 dB below the AGC level specified by the manufacturer.
- f) Slowly increase the signal generator power level until the output signal reaches the AGC operational level.
- g) Reduce the signal generator power to a level that is 3 dB below the level noted above, then manually reset the EUT (e.g., cycle ac/dc power).
- h) Reset the spectrum analyzer span to  $2 \times$  the width of the CMRS band under test. Adjust the tuned frequency of the signal generator to sweep  $2 \times$  the width of the CMRS band using the sweep function. The AGC must be deactivated throughout the entire sweep.
- i) Using three markers, identify the CMRS band edges and the frequency with the highest power. Ensure that the values of all markers are visible on the display of the spectrum analyzer (e.g., marker table set to on).
- j) Capture the spectrum analyzer trace for inclusion in the test report.
- k) Repeat 7.1c) to 7.1j) for all operational uplink and downlink bands with the passband of the booster set to the center of the CMRS band and the highest and lowest passband frequencies of the booster in the CMRS band.

### 3.4 Test protocol

Temperature : 25 °C  
Relative Humidity : 55 %

#### Uplink, 1710-1755MHz

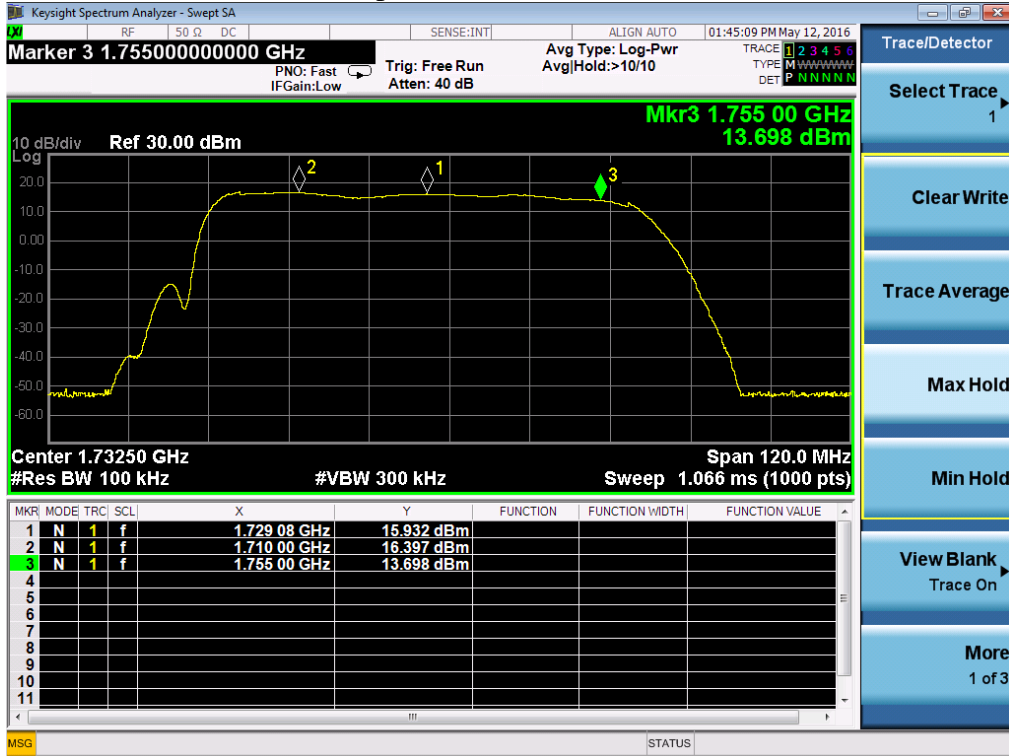

#### Uplink, 824-849MHz

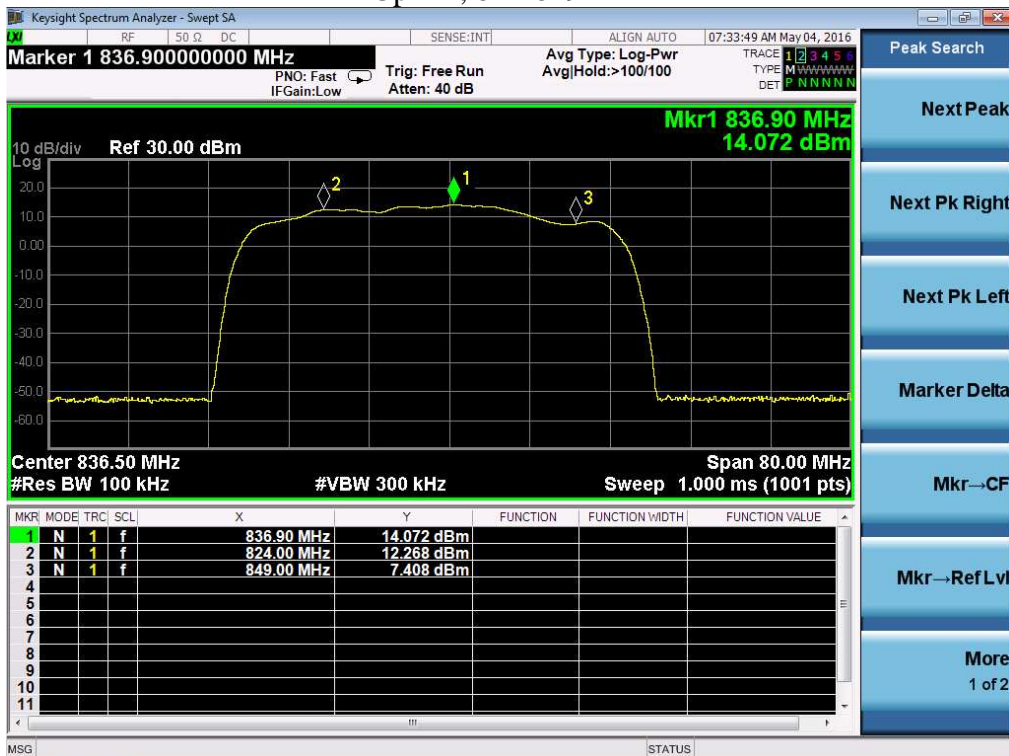

### Uplink, 776-787MHz

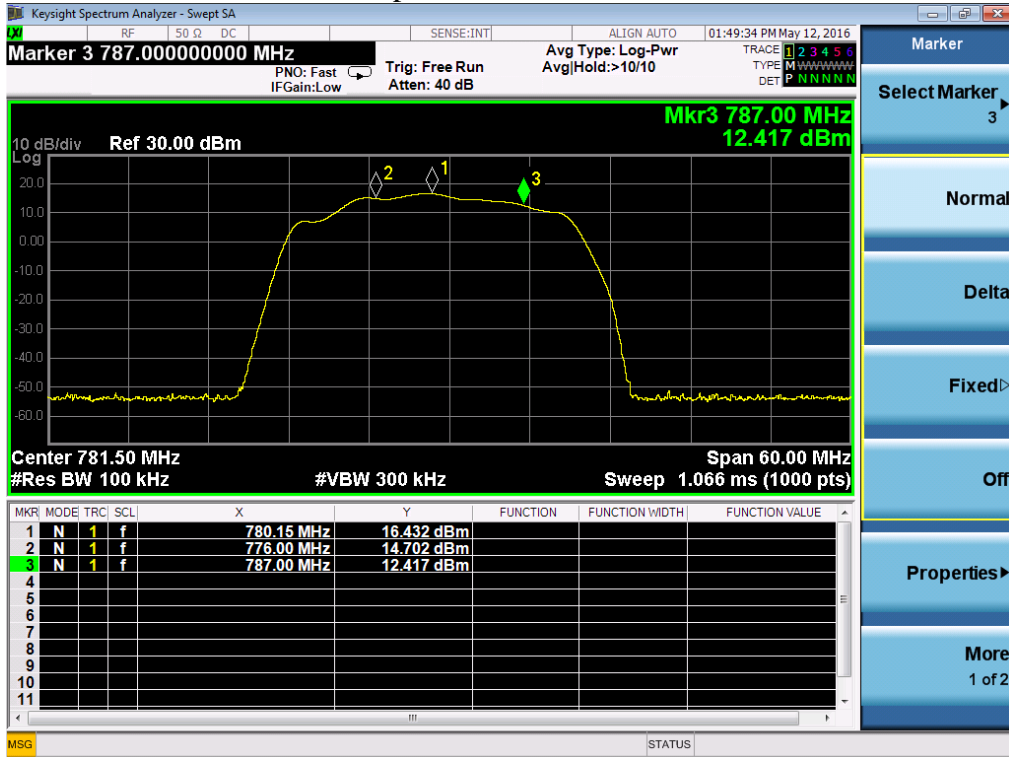

### Uplink, 704-716MHz

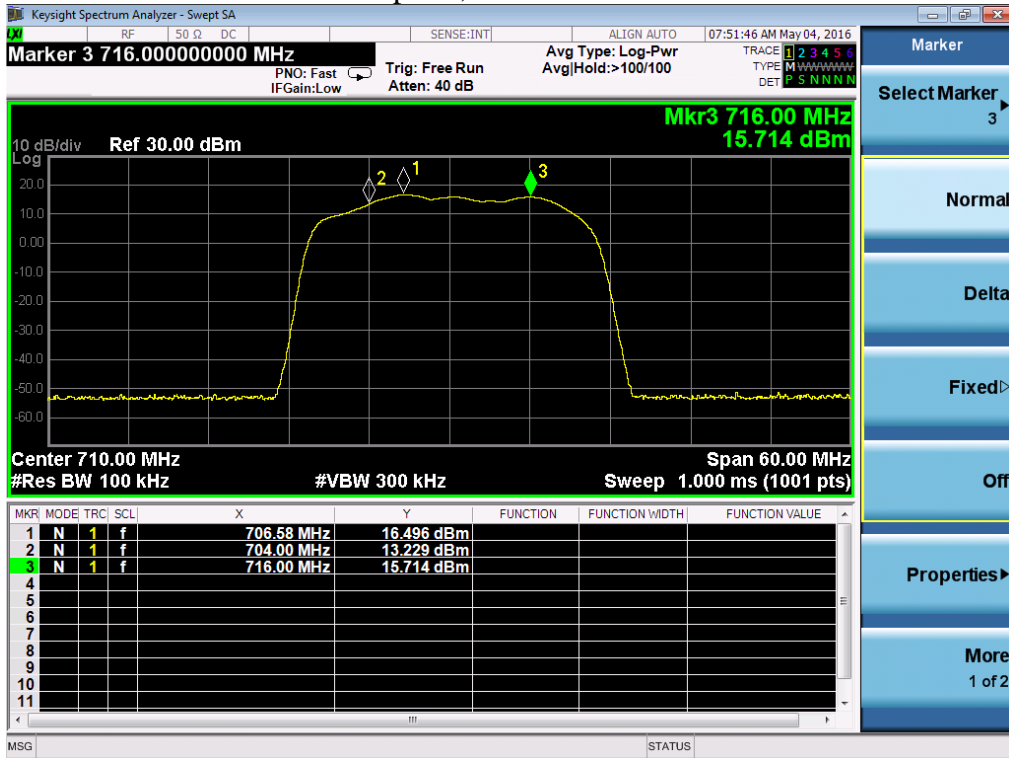

### Uplink, 1850-1910MHz

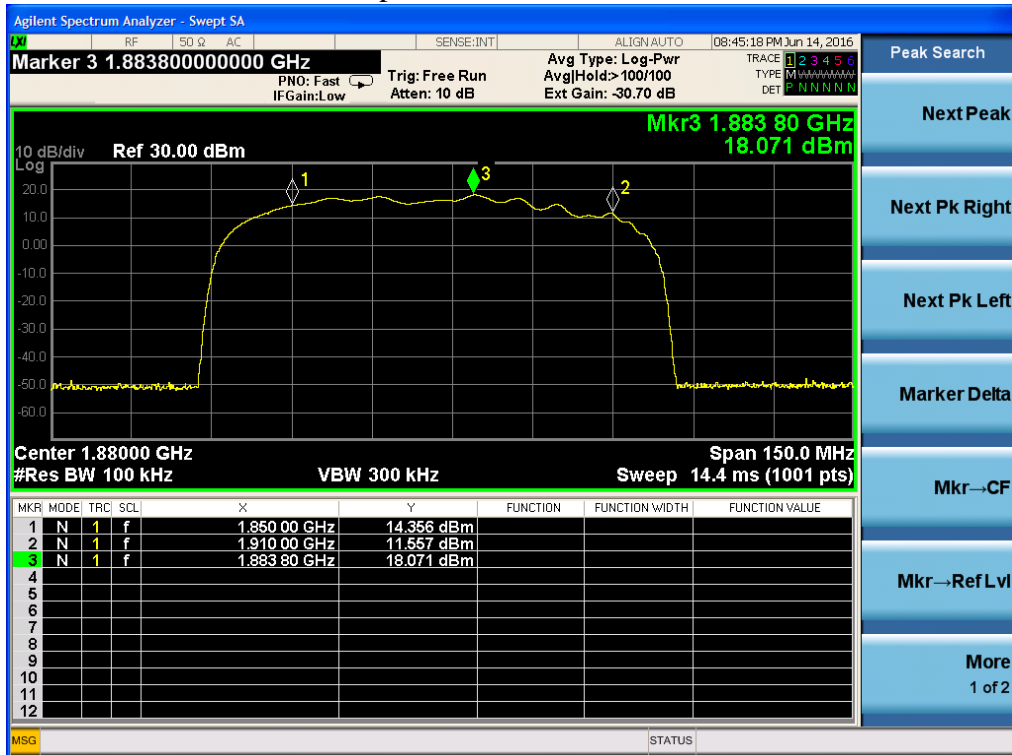

### Downlink, 2110-2155MHz

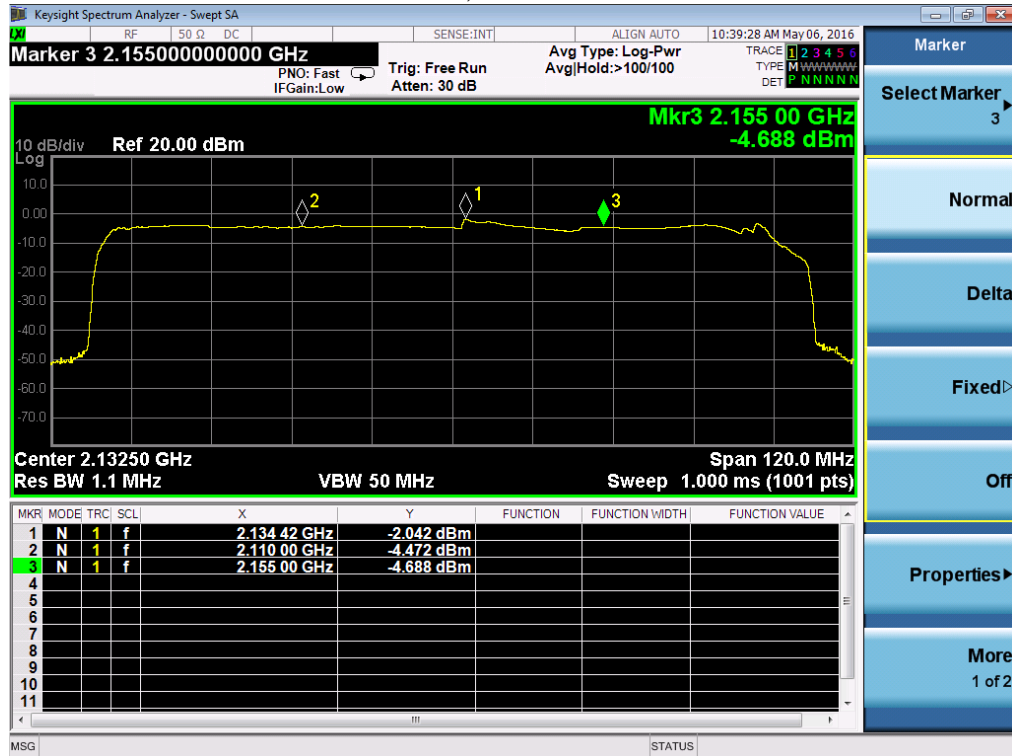

### Downlink, 869-894MHz

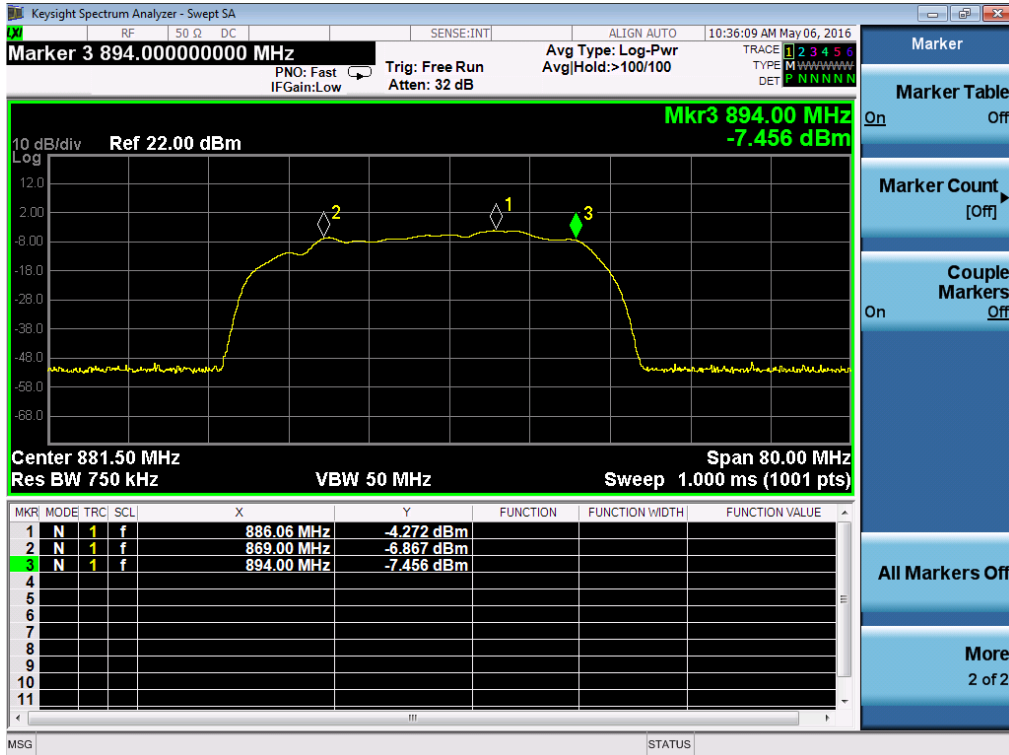

### Downlink, 746-757MHz

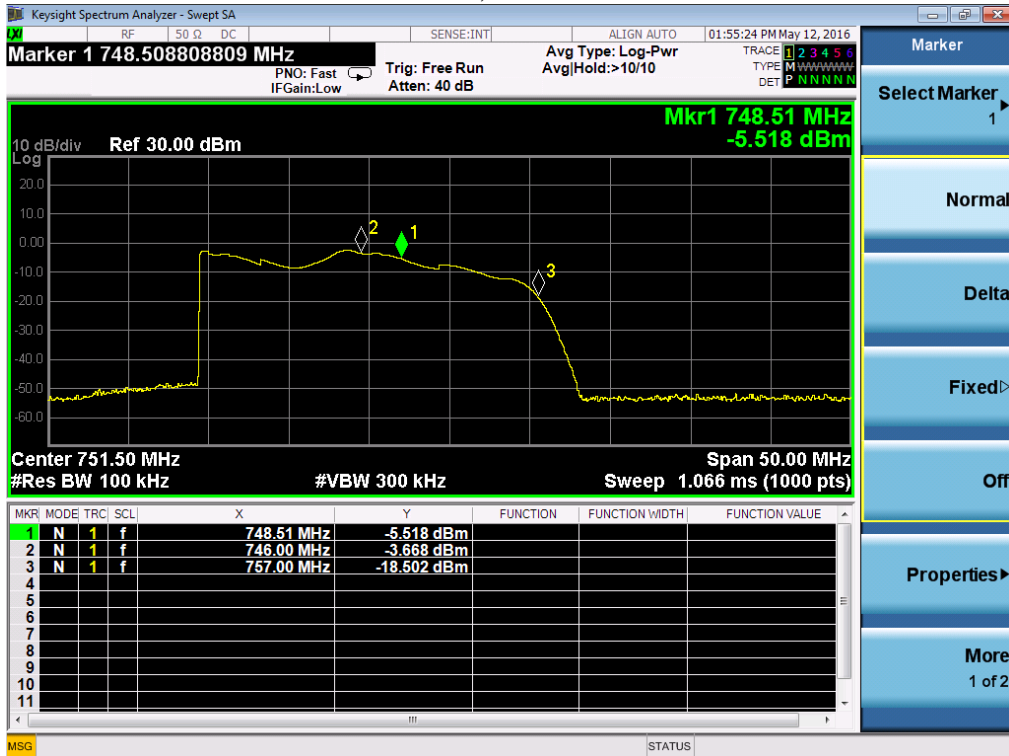

### Downlink, 734-746MHz

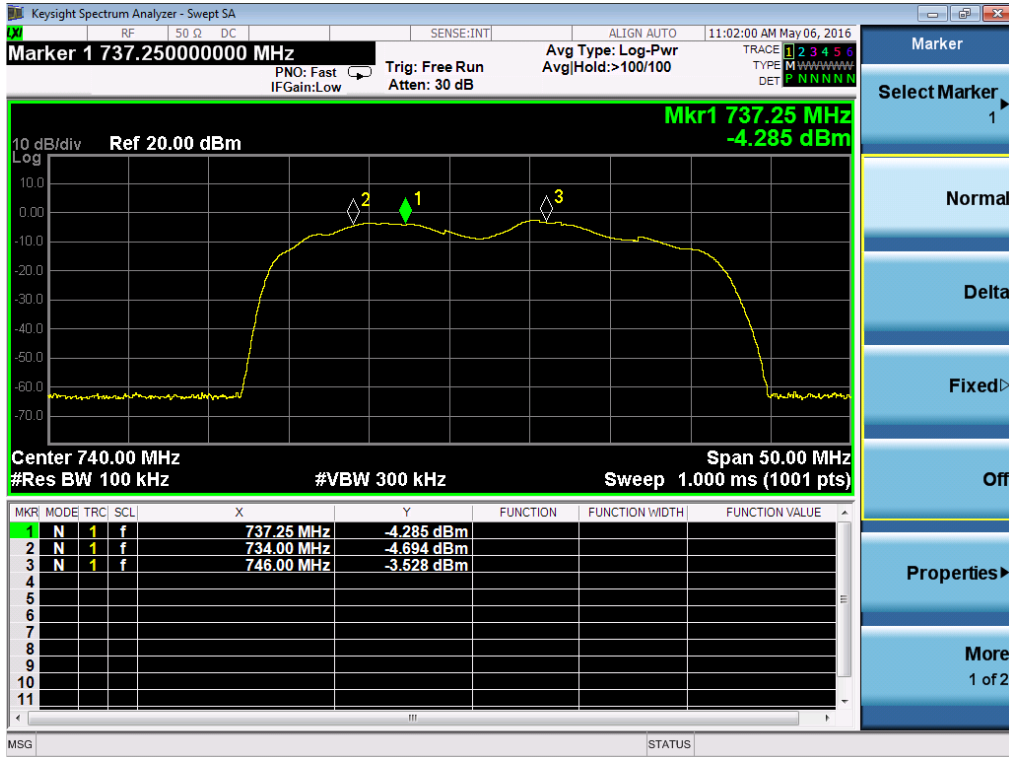

### Downlink, 1930-1990MHz

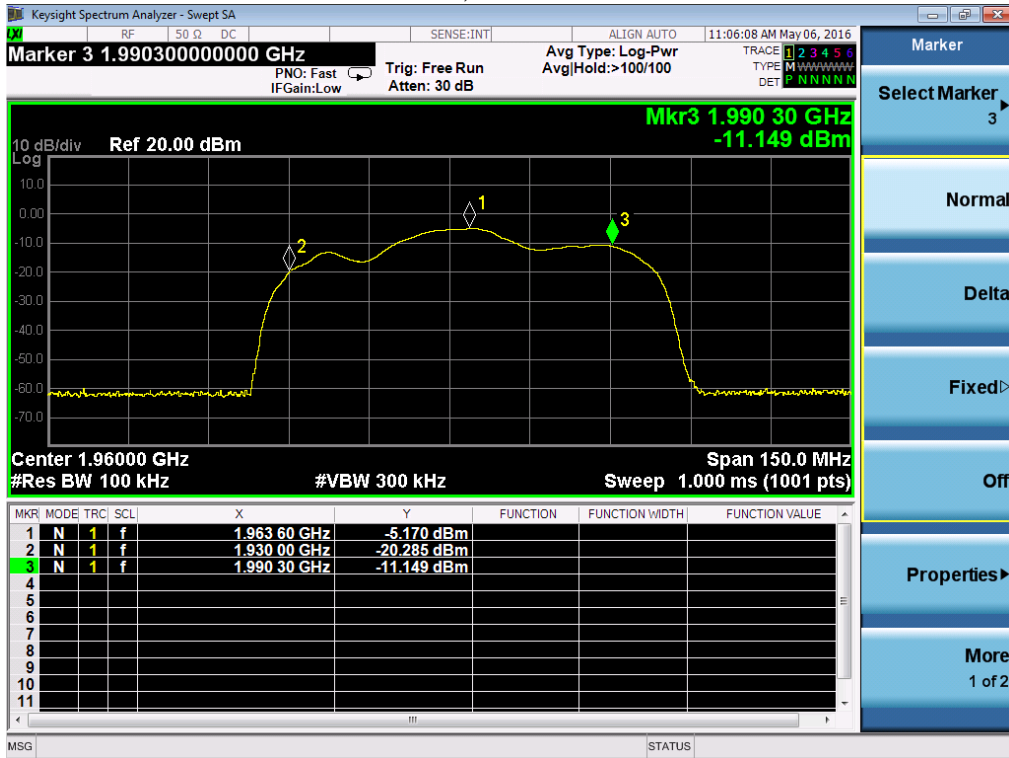

## 4. Maximum power

**Test result:** Pass

### 4.1 Test limit

Uplink: Conducted output  $\geq 17\text{dBm}$ ; EIRP  $\leq 30\text{dBm}$

Downlink: EIRP  $\leq 17\text{dBm}$

### 4.2 Test Configuration

Uplink test configuration

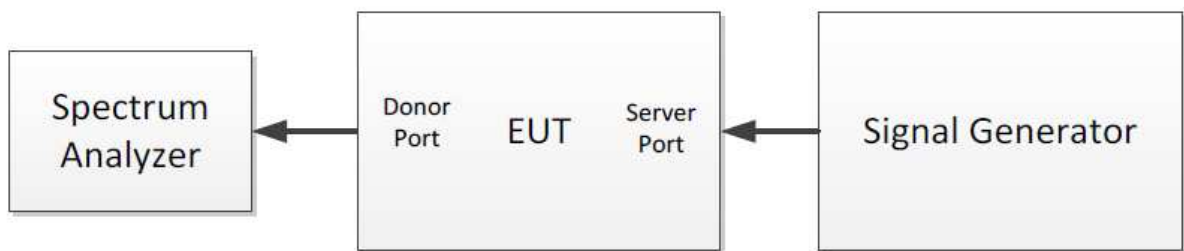

Downlink test configuration



### 4.3 Test procedure and test setup

- a) Connect the EUT in test mode.
- b) Configure the signal generator and spectrum analyzer for operation on the frequency with the highest power level as determined.
- c) Set the initial signal generator power to a level far below the AGC threshold level.
- d) Slowly increase the signal generator power level until the output signal reaches the AGC threshold level as determined from observation of the signal behavior on the spectrum analyzer (i.e., no further increase in output power as input power is increased).
- e) Reduce power sufficiently on the signal generator to ensure that the AGC is not limiting the output power.
- f) Slowly increase the signal generator power to a level just below (and within 0.5 dB of) the AGC threshold without triggering the AGC. Note the signal generator power level as ( $P_{in}$ ).
- g) Measure the output power ( $P_{out}$ ) with the spectrum analyzer as follows.
  - 1) Set RBW = 100 kHz for AWGN signal type, or 300 kHz for CW or GSM signal type.
  - 2) Set VBW  $\geq 3 \cdot$  RBW.
  - 3) Select either the BURST POWER or CHANNEL POWER measurement mode, as appropriate for each signal type. For AWGN, the channel power integration bandwidth shall be the 99% OBW of the 4.1 MHz signal.
  - 4) Select the power averaging (rms) detector.
  - 5) Affirm that the number of measurement points per sweep  $\geq (2 \cdot \text{span}) / \text{RBW}$ .  
*NOTE—This requirement does not apply for BURST power measurement mode.*
  - 6) Set sweep time = auto couple, or as necessary (but no less than auto couple value).
  - 7) Trace average at least 100 traces in power averaging (i.e., rms) mode.
  - 8) Record the measured power level  $P_{out}$ , with one set of results for the GSM or CW input stimulus, and another set of results for the AWGN input stimulus.
- h) Repeat step 7.2.2g) while increasing the signal generator amplitude in 2 dB steps until the maximum input level indicated in 5.5 is reached. Ensure that the EUT maintains compliance with applicable power limits.
- i) Repeat the procedure for each operational uplink and downlink frequency band supported by the booster.
- j) Provide tabulated results in the test report.

#### 4.4 Test Protocol

Temperature : 25 °C  
Relative Humidity : 55 %

Mode	Band (MHz)	Signal type	Input level (dBm)	Output level (dBm)	Ant Gain (dBi)	EIRP (dBm)	Limit (dBm)	
Uplink	1710-1755	AWGN	-42.5	17.32	6.30	23.62	17-30	
		GSM	-41.5	17.02	6.30	23.32		
Uplink	824-849	AWGN	-36.5	17.19	7.64	24.83		
		GSM	-36.5	17.05	7.64	24.69		
Uplink	776-787	AWGN	-33	18.35	7.77	26.12		
		GSM	-33	18.60	7.77	26.37		
Uplink	704-716	AWGN	-36.5	17.13	7.98	25.11		
		GSM	-35.5	17.03	7.98	25.01		
Uplink	1850-1910	AWGN	-40	17.80	6.12	23.92		
		GSM	-39.5	18.10	6.12	24.22		
Downlink	2110-2155	AWGN	-63	-4.01	5.87	1.86		<17
		GSM	-61	-2.73	5.87	3.14		
Downlink	869-894	AWGN	-57	-5.04	5.11	0.07		
		GSM	-56	-4.51	5.11	0.60		
Downlink	746-757	AWGN	-59	-6.90	5.00	-1.90		
		GSM	-57	-5.72	5.00	-0.72		
Downlink	734-746	AWGN	-59	-6.28	5.00	-1.28		
		GSM	-57	-4.73	5.00	0.27		
Downlink	1930-1990	AWGN	-61	-4.85	5.45	0.60		
		GSM	-59	-3.56	5.45	1.89		

Note: 1. Here the 'Ant gain' has included cable loss of antenna feeder cable.  
2. Here the 'Ant gain' is the highest one showed in the antenna list.

## 5. Maximum booster gain computation

**Test result:** Pass

### 5.1 Test limit

Gain Limit (dB) =  $6.5 \text{ dB} + 20\text{Log}(F_{\text{MHz}})$  while  $F_{\text{MHz}}$  is the uplink mid-band frequency with the downlink gain limit being equivalent to the paired Uplink band gain limit.

The difference between uplink and downlink gain should be  $\leq 9\text{dB}$ .

### 5.2 Test Configuration

Uplink test configuration

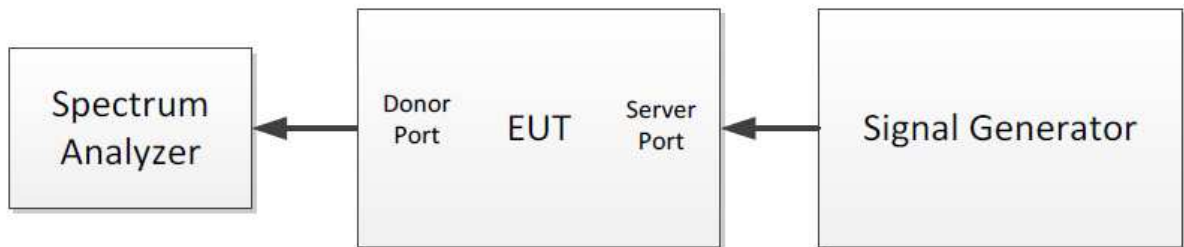

Downlink test configuration

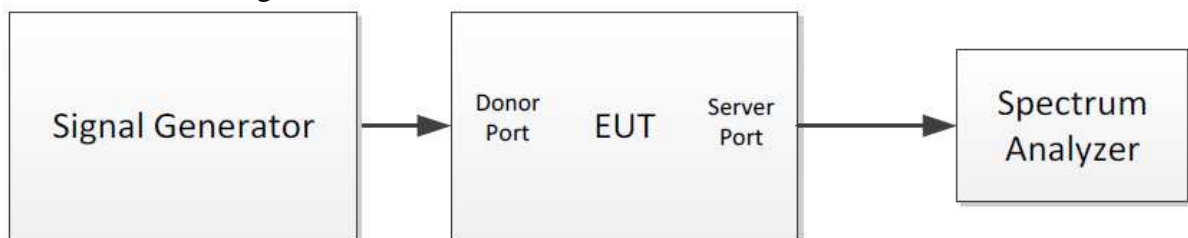

### 5.3 Test procedure and test setup

- a) Connect the EUT in test mode.
- b) Configure the signal generator and spectrum analyzer for operation on the frequency with the highest power level as determined.
- c) Set the initial signal generator power to a level far below the AGC threshold level.
- d) Slowly increase the signal generator power level until the output signal reaches the AGC threshold level as determined from observation of the signal behavior on the spectrum analyzer (i.e., no further increase in output power as input power is increased).
- e) Reduce power sufficiently on the signal generator to ensure that the AGC is not limiting the output power.
- f) Slowly increase the signal generator power to a level just below (and within 0.5 dB of) the AGC threshold without triggering the AGC. Note the signal generator power level as (P<sub>in</sub>).
- g) Measure the output power (P<sub>out</sub>) with the spectrum analyzer as follows.
  - 1) Set RBW = 100 kHz for AWGN signal type, or 300 kHz for CW or GSM signal type.
  - 2) Set VBW  $\geq 3 \cdot$  RBW.
  - 3) Select either the BURST POWER or CHANNEL POWER measurement mode, as appropriate for each signal type. For AWGN, the channel power integration bandwidth shall be the 99% OBW of the 4.1 MHz signal.
  - 4) Select the power averaging (rms) detector.
  - 5) Affirm that the number of measurement points per sweep  $\geq (2 \cdot \text{span}) / \text{RBW}$ .  
*NOTE—This requirement does not apply for BURST power measurement mode.*
  - 6) Set sweep time = auto couple, or as necessary (but no less than auto couple value).
  - 7) Trace average at least 100 traces in power averaging (i.e., rms) mode.
  - 8) Record the measured power level P<sub>out</sub>, with one set of results for the GSM or CW input stimulus, and another set of results for the AWGN input stimulus.
- h) Repeat step g) while increasing the signal generator amplitude in 2 dB steps until the maximum input level is reached. Ensure that the EUT maintains compliance with applicable power limits.
- i) Repeat the procedure for each operational uplink and downlink frequency band supported by the booster.
- j) Provide tabulated results in the test report.

### 5.4 Test Protocol

Temperature : 25 °C  
Relative Humidity : 55 %

Gain Limit calculation	
Central frequency of uplink band (MHz)	Calculated Limit (dBi)
1732.5	71.27
836.5	64.95
781.5	64.36
710	63.53
1880	71.98

Note: Gain Limit (dB) = 6.5 + 20Log(F<sub>MHz</sub>)

Gain test result							
Uplink Band (MHz)	Downlink Band (MHz)	Signal type	Uplink Gain (dBi)	Downlink Gain (dBi)	Gain limit (dBi)	Delta Gain (dB)	Delta Limit (dBm)
1710-1755	2110-2155	AWGN	59.82	58.99	71.27	0.83	-9~9
		GSM	58.52	58.27	71.27	0.25	-9~9
824-849	869-894	AWGN	53.69	51.96	64.95	1.73	-9~9
		GSM	53.55	51.49	64.95	2.06	-9~9
776-787	746-757	AWGN	51.35	52.10	64.36	-0.75	-9~9
		GSM	51.60	51.28	64.36	0.32	-9~9
704-716	734-746	AWGN	53.63	52.72	63.53	0.91	-9~9
		GSM	52.53	52.27	63.53	0.26	-9~9
1850-1910	1930-1990	AWGN	57.80	56.15	71.98	1.65	-9~9
		GSM	57.60	55.44	71.98	2.16	-9~9

Note: 1. Uplink gain / Downlink gain = output level – input level among maximum power test;  
2. Delta gain = Uplink gain - Downlink gain

## 6. Inter-modulation

Test result: Pass

### 6.1 Test limit

Inter-modulation Level  $\leq$  -19dBm

### 6.2 Test Configuration

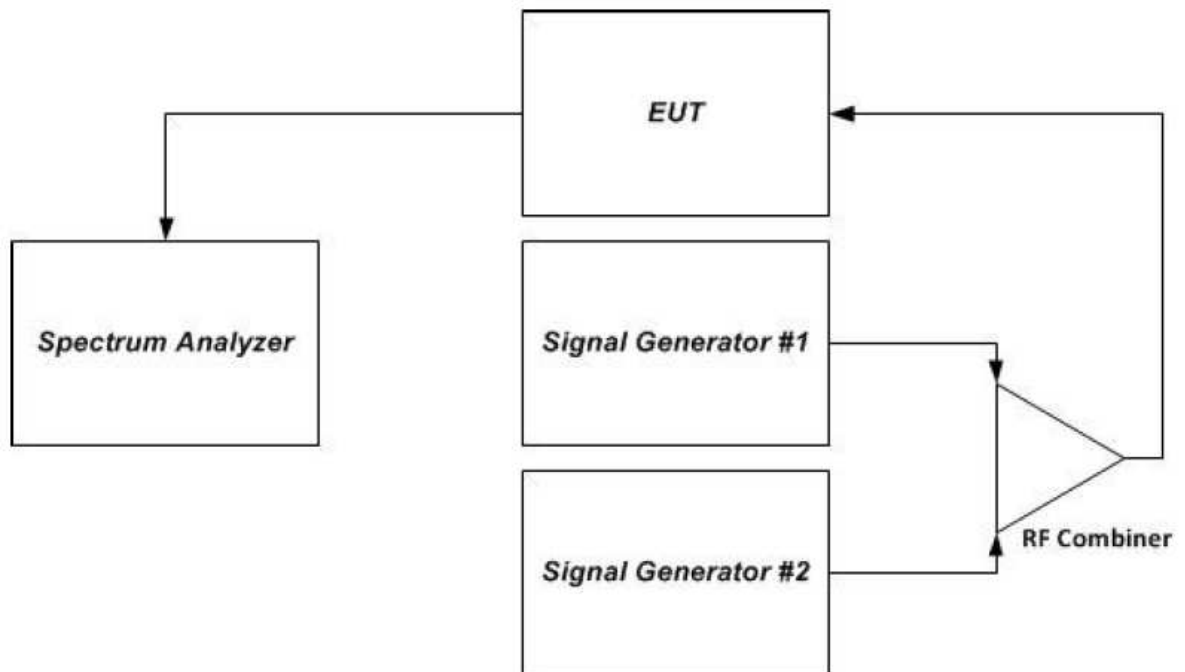

### 6.3 Test procedure and test setup

- a) Begin with the uplink output (donor) port connected to the spectrum analyzer.
- b) Set the spectrum analyzer RBW = 3kHz.
- c) Set the VBW  $\geq 3 \times$  RBW.
- d) Select the rms detector.
- e) Set the spectrum analyzer center frequency to the center of the supported operational band under test.
- f) Set the span to 5MHz. Affirm that the number of measurement points per sweep  $\geq (2 \times \text{span})/\text{RBW}$ .
- g) Configure the two signal generators for CW operation with generator #1 tuned 300 kHz below the operational band center frequency and generator #2 tuned 300 kHz above the operational band center frequency.
- h) Set the signal generator amplitudes so that the power from each into the RF combiner is equivalent, then turn on the RF output.
- i) Simultaneously increase each signal generators' amplitude equally until just before the EUT begins AGC, then affirm that all intermodulation-product emissions (if any occur) are below the specified limit of  $-19\text{dBm}$ .
- j) Use the trace averaging function of the spectrum analyzer, and wait for the trace to stabilize. Place a marker at the highest amplitude intermodulation-product emission.
- k) Record the maximum intermodulation product amplitude level that is observed.
- l) Capture the spectrum analyzer trace for inclusion in the test report.
- m) Repeat 7.4e) to 7.4l) for all uplink and downlink operational bands.  
*NOTE—If using a single signal generator with dual outputs, affirm that intermodulation products are not the result of the generator.*
- n) Increase the signal generator amplitude in 2 dB steps to 10 dB above the AGC threshold, but not exceeding the maximum input level of power test, to affirm that the EUT maintains compliance with the intermodulation limit.

### 6.4 Test Protocol

Temperature : 25 °C  
Relative Humidity : 55 %

Mode	Band (MHz)	Intermodulation Level (dBm)	Limit (dBm)
Uplink	1710-1755	-32.55	-19
Uplink	824-849	<-25.00	
Uplink	776-787	-21.55	
Uplink	704-716	-22.20	
Uplink	1850-1910	<-25.00	
Downlink	2110-2155	<-25.00	
Downlink	869-894	<-25.00	
Downlink	746-757	<-25.00	
Downlink	734-746	<-25.00	
Downlink	1930-1990	<-25.00	

### Uplink, 1710-1755MHz

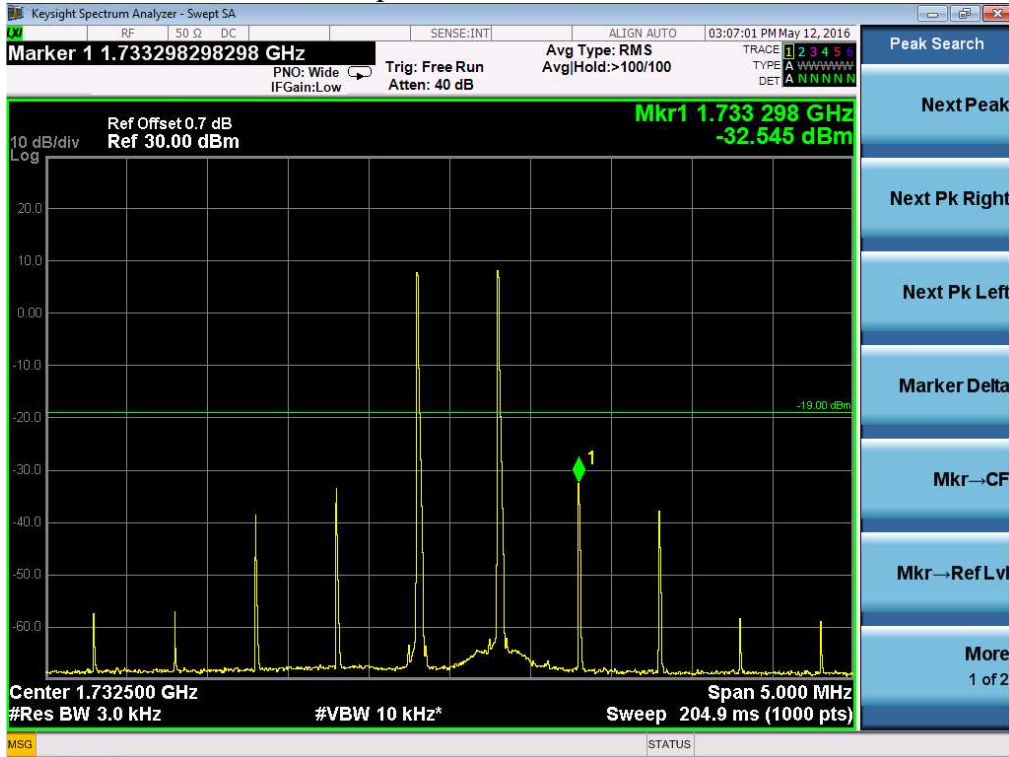

### Uplink, 824-849MHz

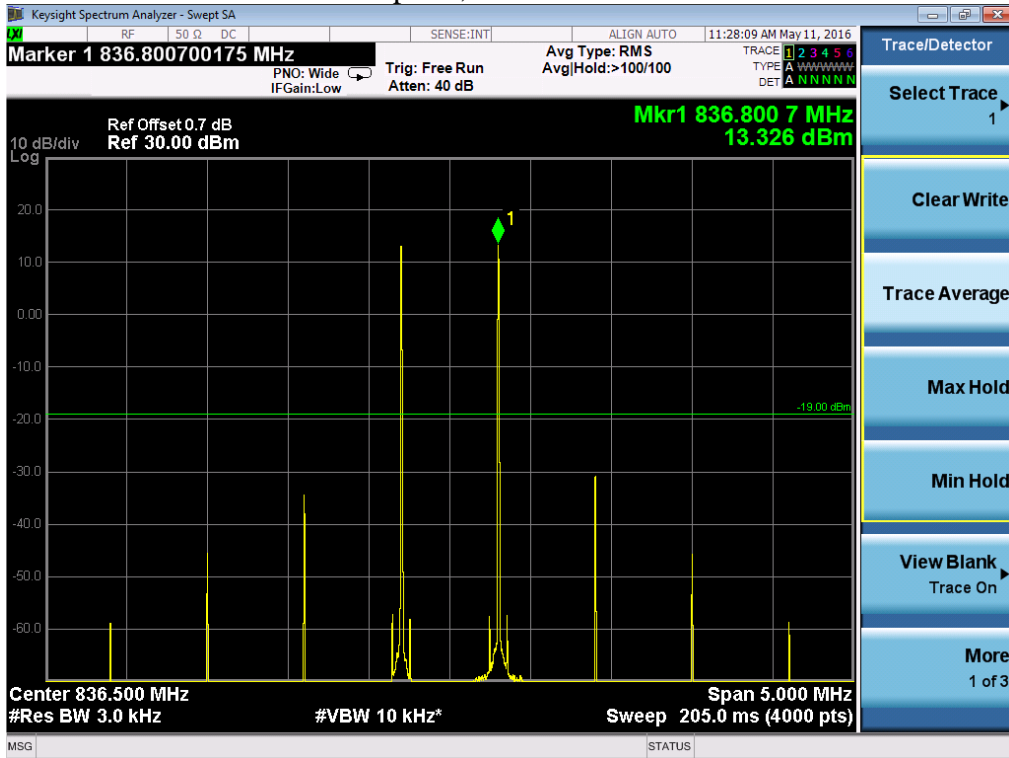

### Uplink, 776-787MHz

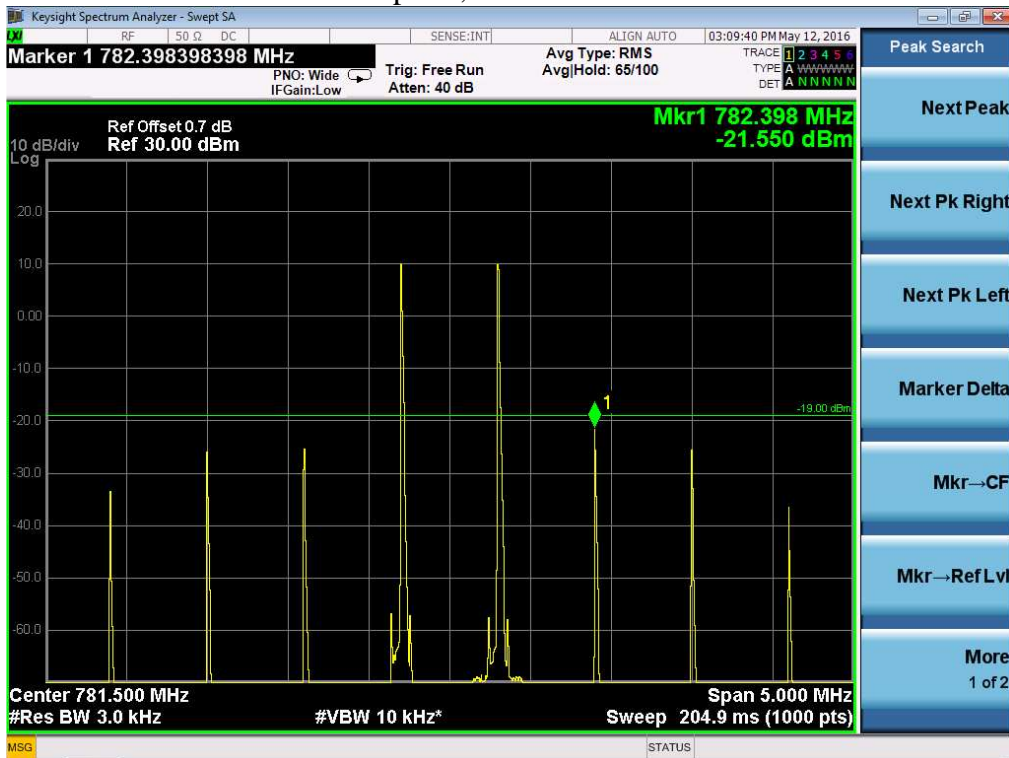

### Uplink, 704-716MHz

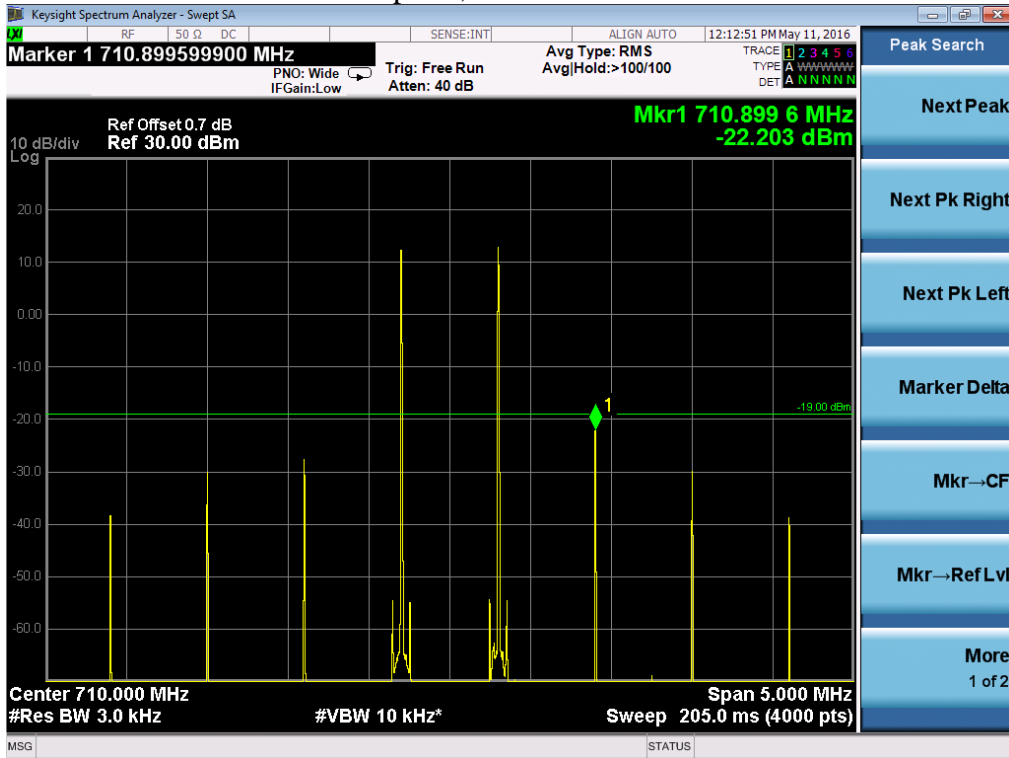

### Uplink, 1850-1910MHz

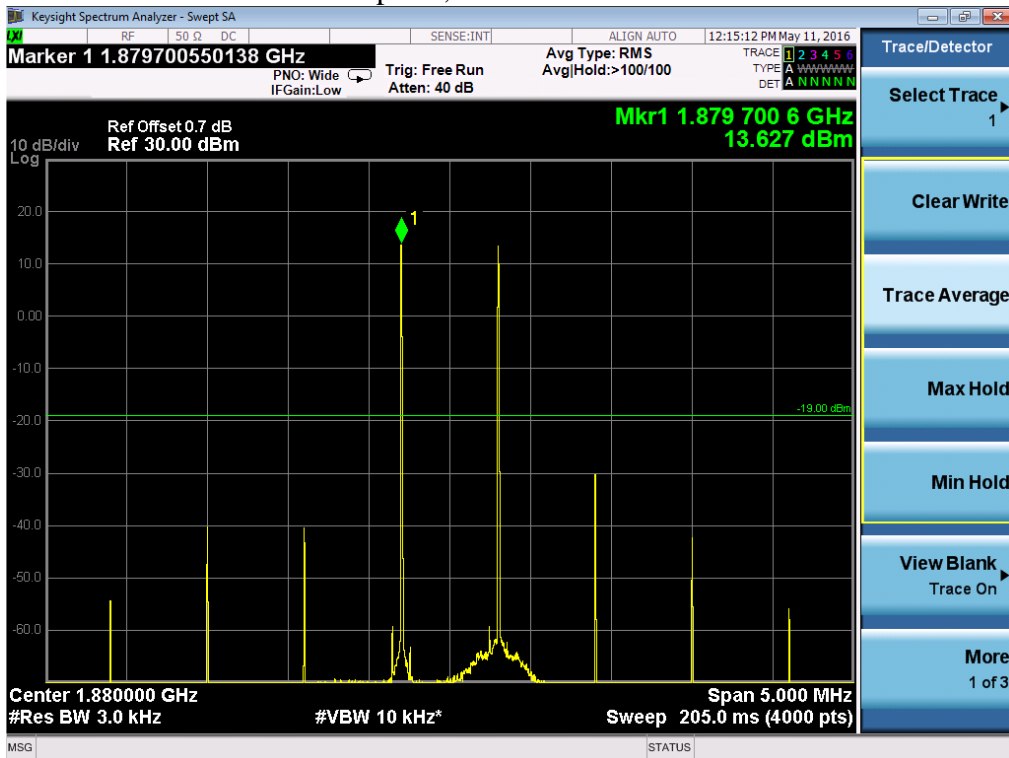

### Downlink, 2110-2155MHz

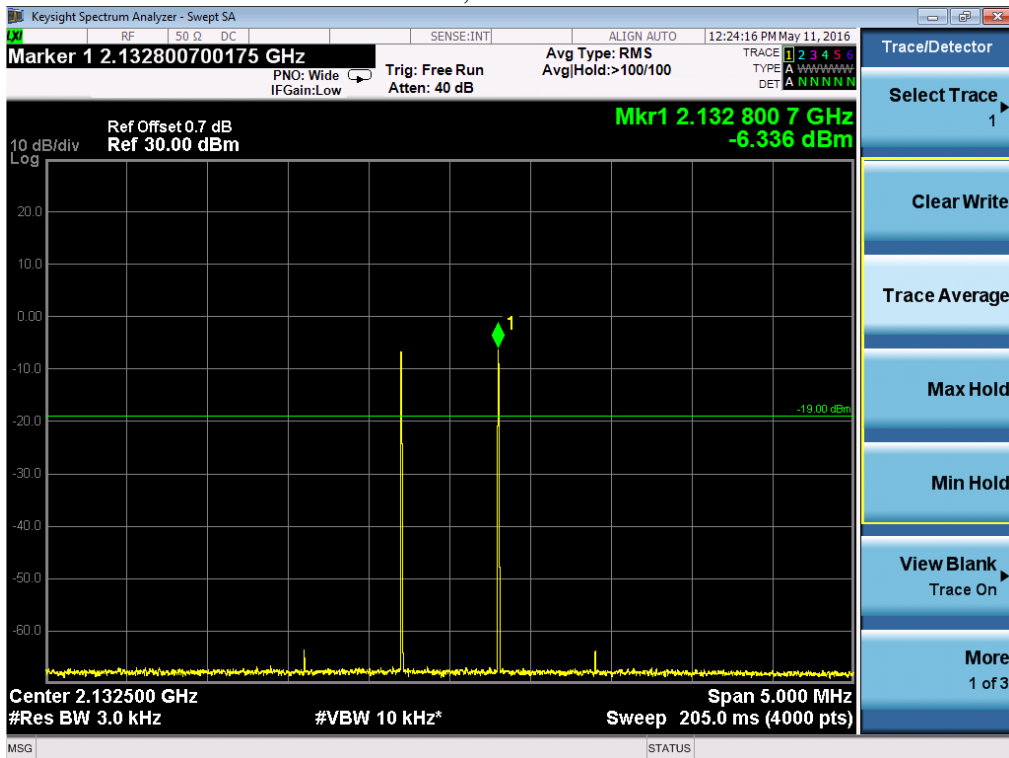

### Downlink, 869-894MHz

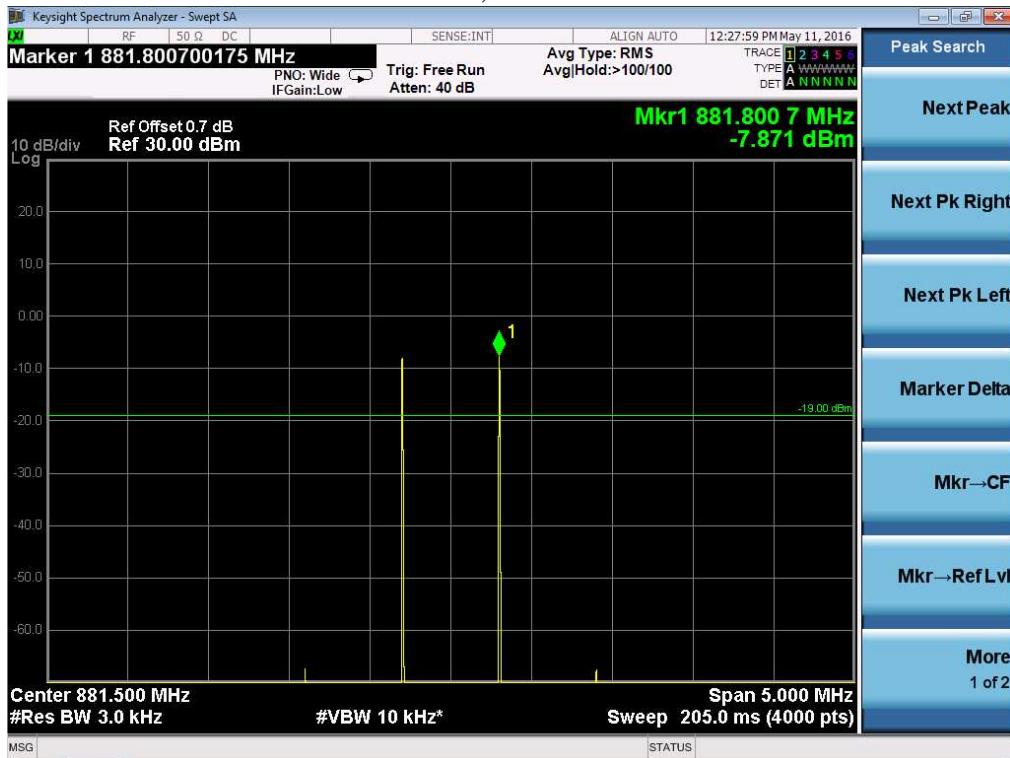

### Downlink, 746-757MHz

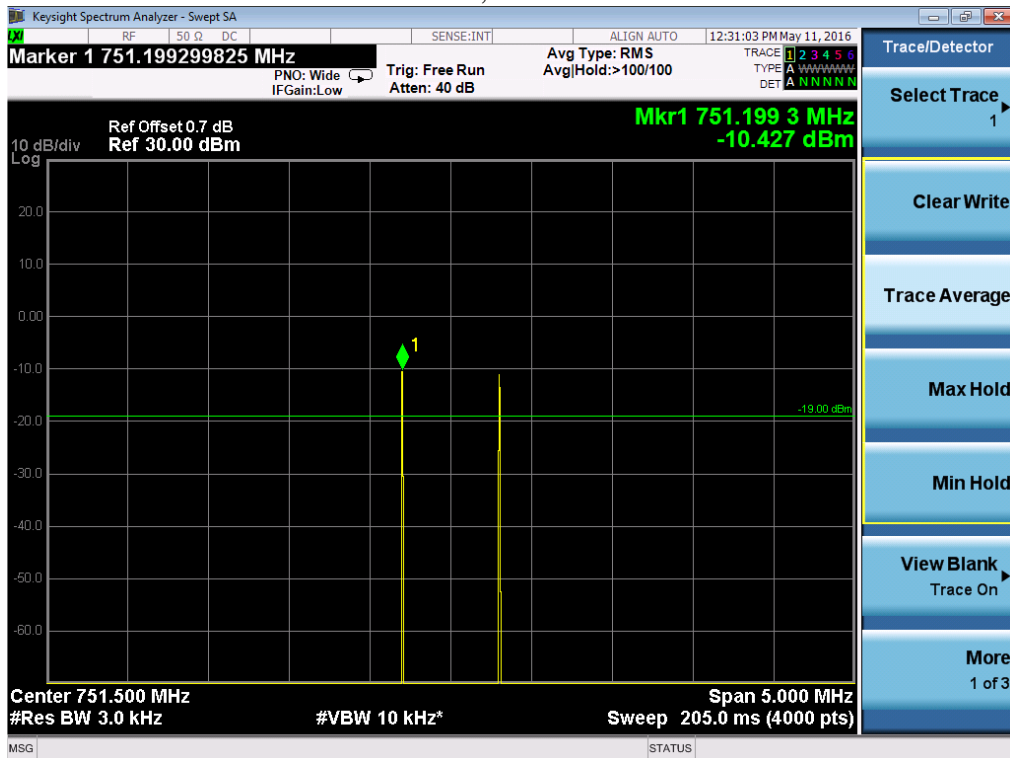

### Downlink, 734-746MHz

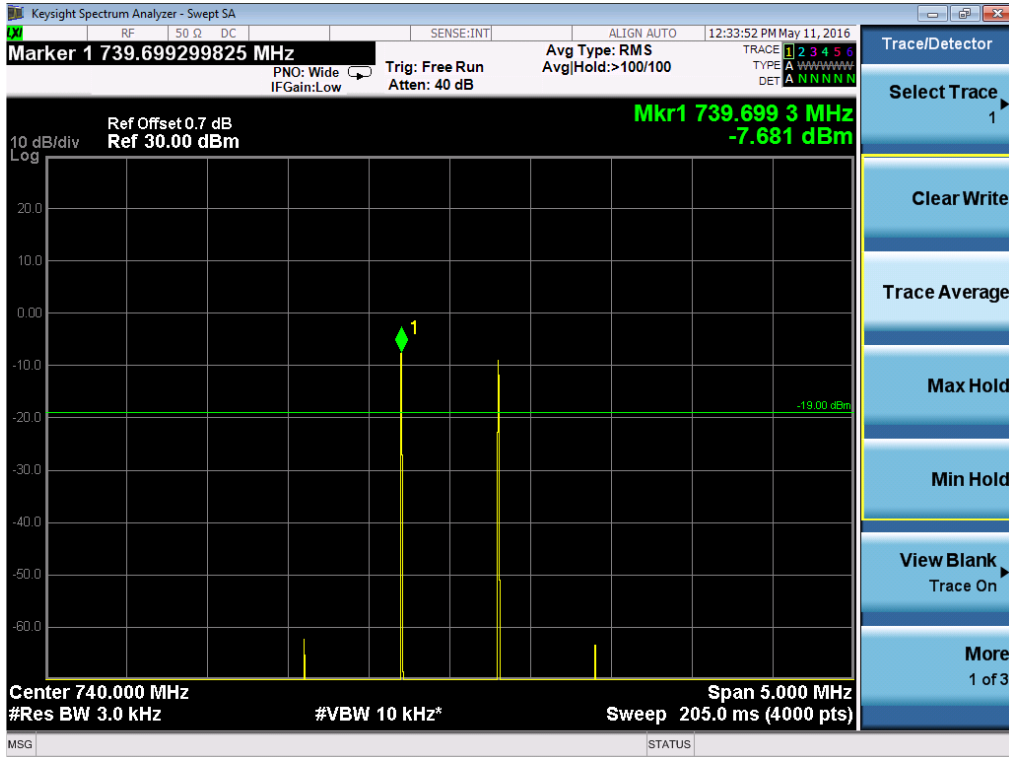

### Downlink, 1930-1990MHz

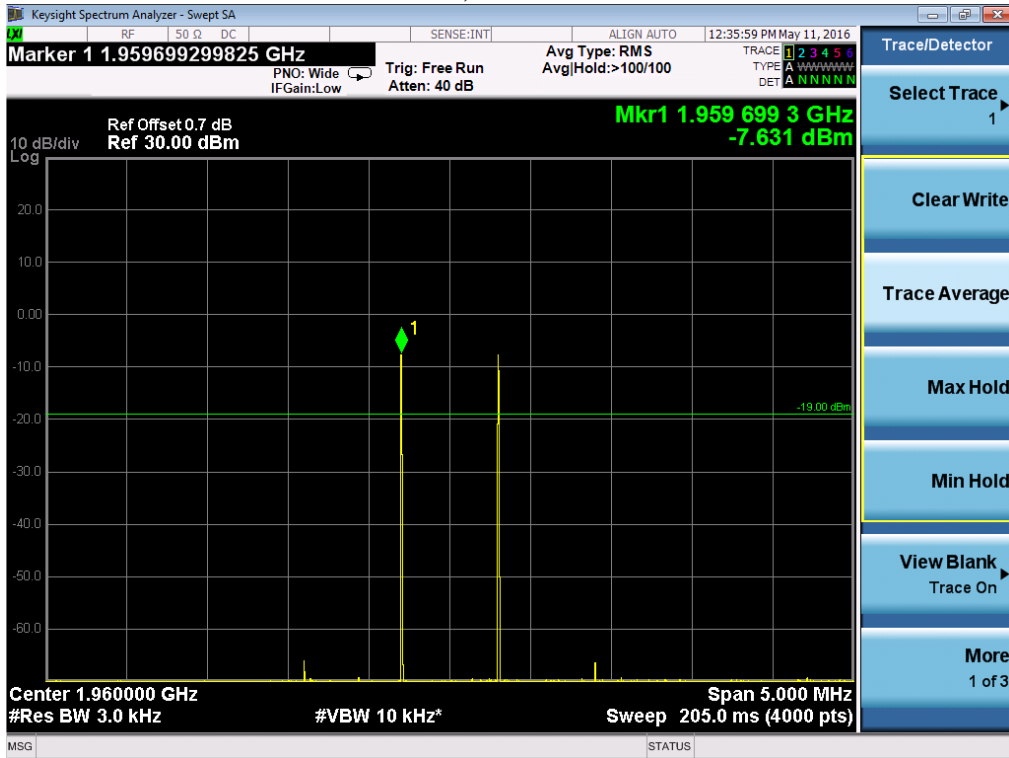

## 7. Out-of-band emissions

**Test result:** Pass

### 7.1 Test limit

Out-of-band Emissions Limit =  $P1 - 6 - (43 + 10\text{Log}(P2)) = -19\text{dBm}$

P1 = power in dBm

P2 = power in Watts

### 7.2 Test Configuration

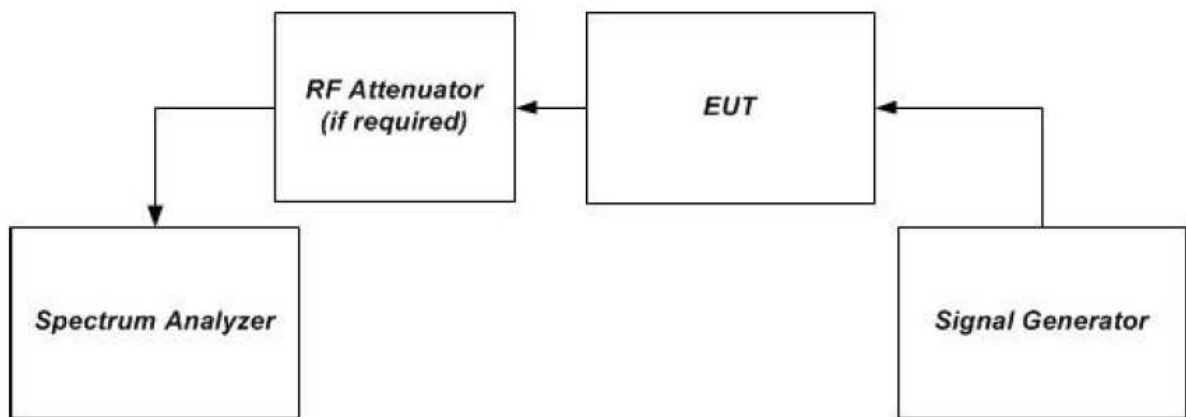

### 7.3 Test procedure and test setup

- a) Begin with the uplink output (donor) port connected to the spectrum analyzer.
- b) Configure the signal generator for the appropriate operation for all uplink and downlink bands:
  - 1) GSM: 0.2 MHz from upper and lower band edges.
  - 2) LTE (5 MHz): 2.5 MHz from upper and lower band edges.
  - 3) CDMA: 1.25 MHz from upper and lower band edges, except for cellular band as follows (only the upper and lower frequencies need to be tested):  
824.88 MHz, 845.73 MHz, 836.52 MHz, 848.10 MHz,  
869.88 MHz, 890.73 MHz, 881.52 MHz, 893.10 MHz.  
*NOTE 1—Alternative test modulation types:*  
CDMA (alternative 1.25 MHz AWGN)  
LTE 5 MHz (alternative W-CDMA or 4.1 MHz AWGN)  
*NOTE 2—For LTE, the signal generator should use the uplink and downlink signal types for these modulations in uplink and downlink tests, respectively. LTE shall use 5 MHz signal, 25 resource blocks transmitting.*  
*NOTE 3—When using an AWGN test signal, the bandwidth shall be the measured 99% OBW.*
- c) Set the signal generator amplitude to the maximum power level prior to AGC similar to the power measurement procedures for the appropriate modulations.
- d) Set RBW = measurement bandwidth specified in the applicable rule section for the supported frequency band.
- e) Set VBW = 3\* RBW.
- f) Select the power averaging (rms) detector.
- g) Sweep time = auto-couple.
- h) Set the analyzer start frequency to the upper band/block edge frequency and the stop frequency to the upper band/block edge frequency plus: 300 kHz (when operational frequency is < 1 GHz), or 3 MHz (when operational frequency is ≥ 1 GHz).
- i) Trace average at least 100 traces in power averaging (i.e., rms) mode.
- j) Use peak marker function to find the maximum power level.
- k) Capture the spectrum analyzer trace of the power level for inclusion in the test report.
- l) Increase the signal generator amplitude in 2 dB steps until the maximum input level is reached. Affirm that the EUT maintains compliance with the OOB limits.
- m) Reset the analyzer start frequency to the lower band/block edge frequency minus: 300 kHz (when operational frequency is < 1 GHz), or 3 MHz (when operational frequency is ≥ 1 GHz), and the stop frequency to the lower band/block edge frequency, then repeat i) to l).
- n) Repeat b) through m) for each uplink and downlink operational band.

### 7.4 Test Protocol

Temperature : 25 °C  
Relative Humidity : 55 %

Signal Type	Mode	Band (MHz)	Max reading (dBm)	Limit (dBm)
CDMA	Uplink-H	1710-1755	<-23	-19
	Uplink-L	1710-1755	<-23	
	Uplink-H	824-849	<-23	
	Uplink-L	824-849	<-23	
	Uplink-H	776-787	<-23	
	Uplink-L	776-787	<-23	
	Uplink-H	704-716	<-23	
	Uplink-L	704-716	<-23	
	Uplink-H	1850-1910	<-23	
	Uplink-L	1850-1910	<-23	
	Downlink-H	2110-2155	<-23	
	Downlink-L	2110-2155	<-23	
	Downlink-H	869-894	<-23	
	Downlink-L	869-894	<-23	
	Downlink-H	746-757	<-23	
	Downlink-L	746-757	<-23	
	Downlink-H	734-746	<-23	
	Downlink-L	734-746	<-23	
	Downlink-H	1930-1990	<-23	
	Downlink-L	1930-1990	<-23	

Uplink-H	1710-1755
----------	-----------



Uplink-L	1710-1755
----------	-----------



Uplink-H	824-849
----------	---------

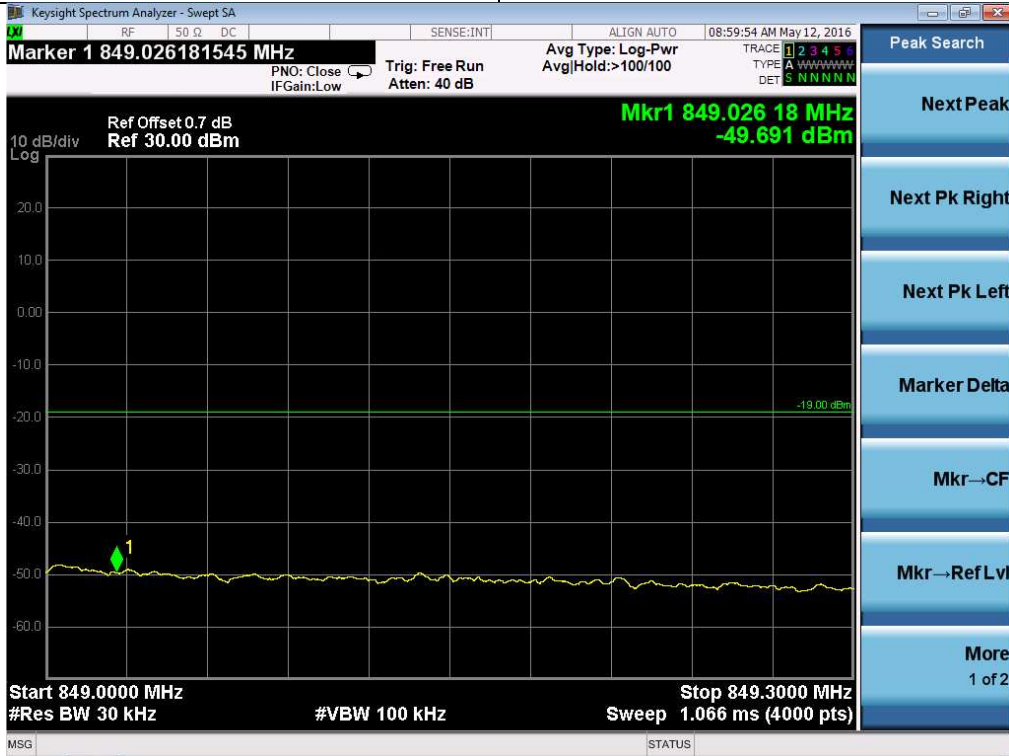

Uplink-L	824-849
----------	---------

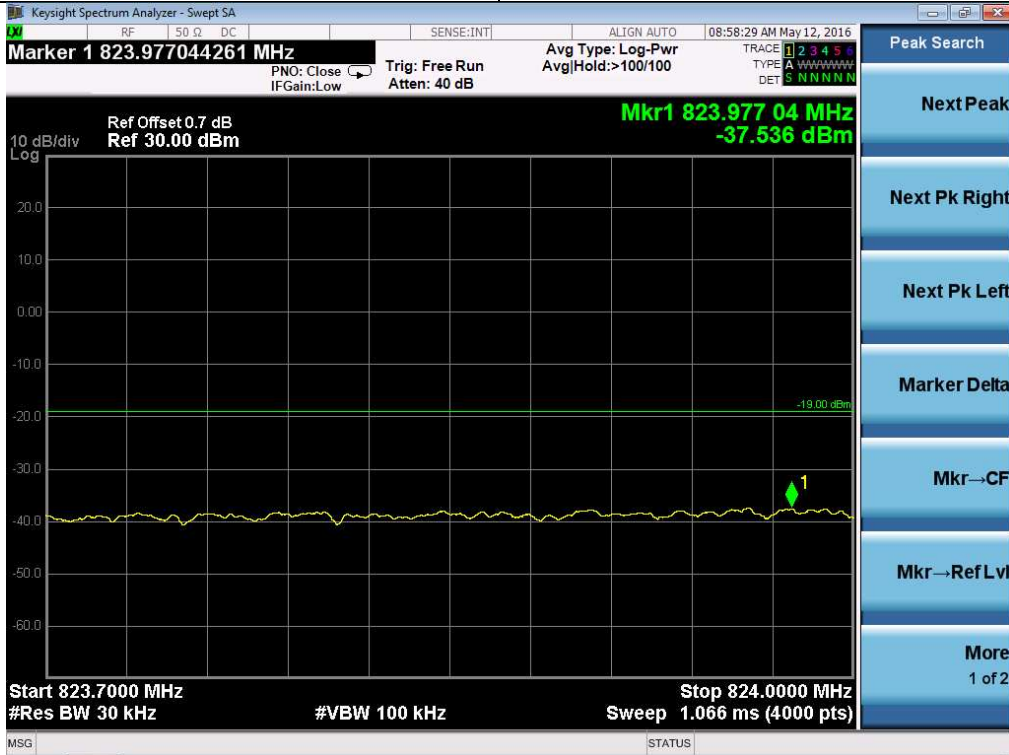

Uplink-H	776-787
----------	---------

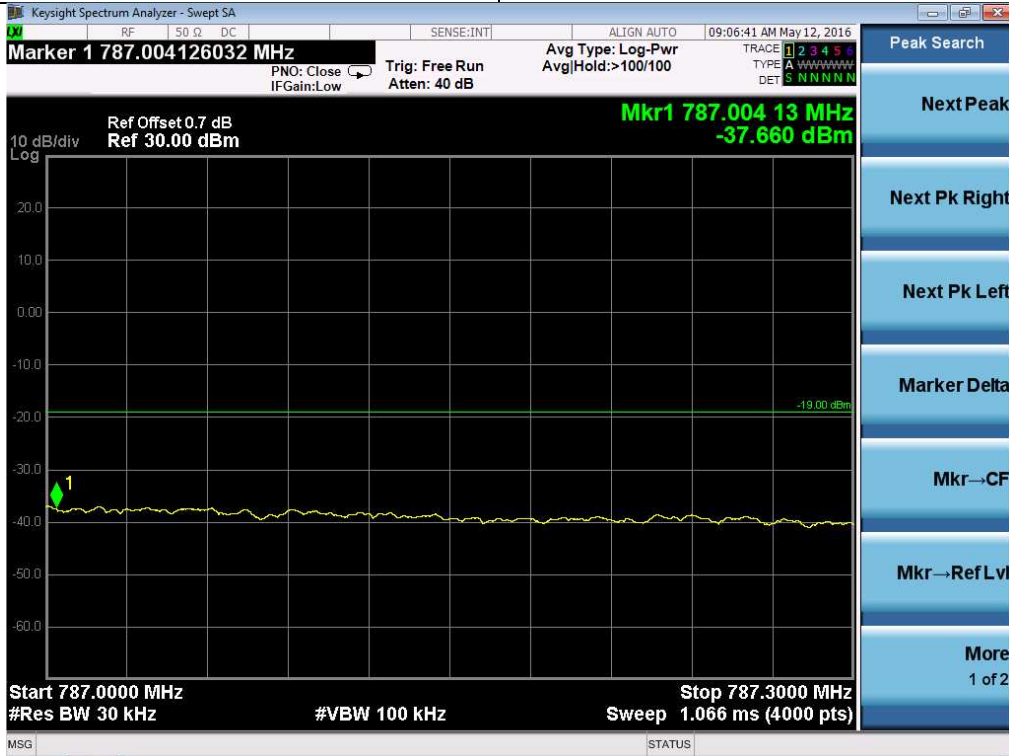

Uplink-L	776-787
----------	---------

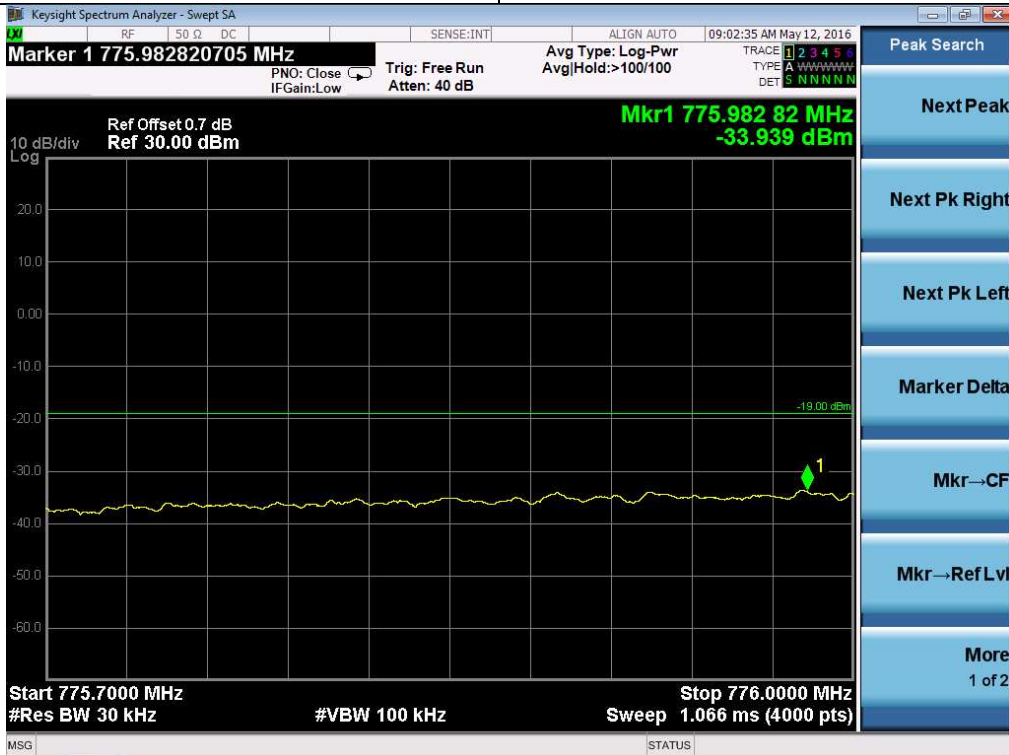

Uplink-H	704-716
----------	---------

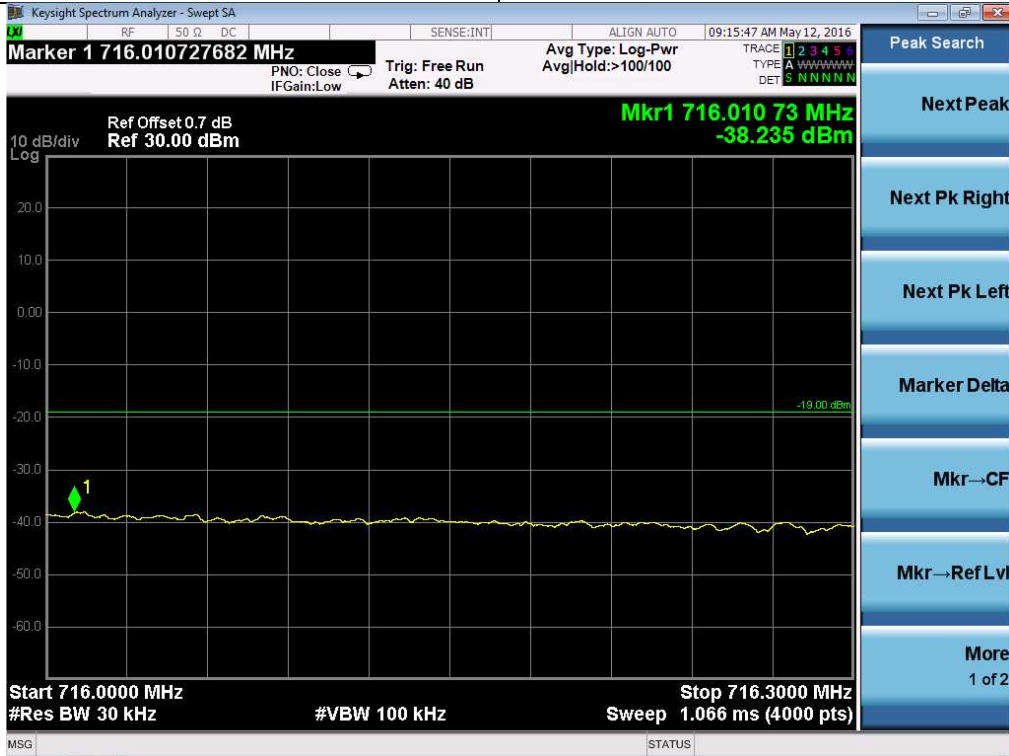

Uplink-L	704-716
----------	---------

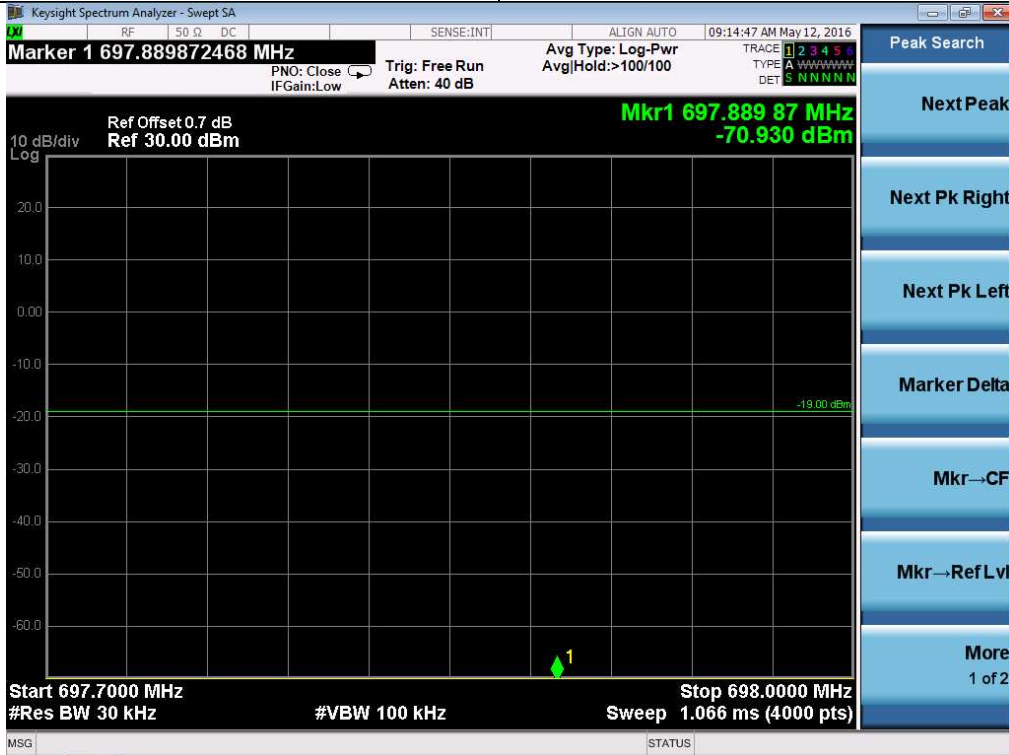

Uplink-H	1850-1910
----------	-----------

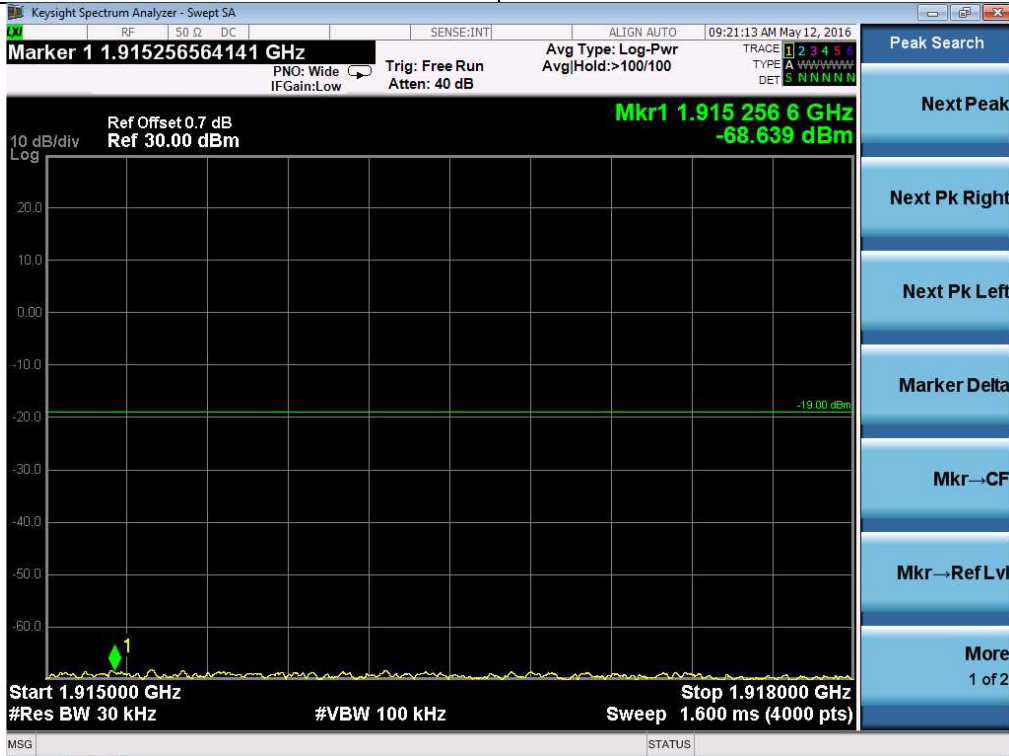

Uplink-L	1850-1910
----------	-----------



Downlink-H	2110-2155
------------	-----------

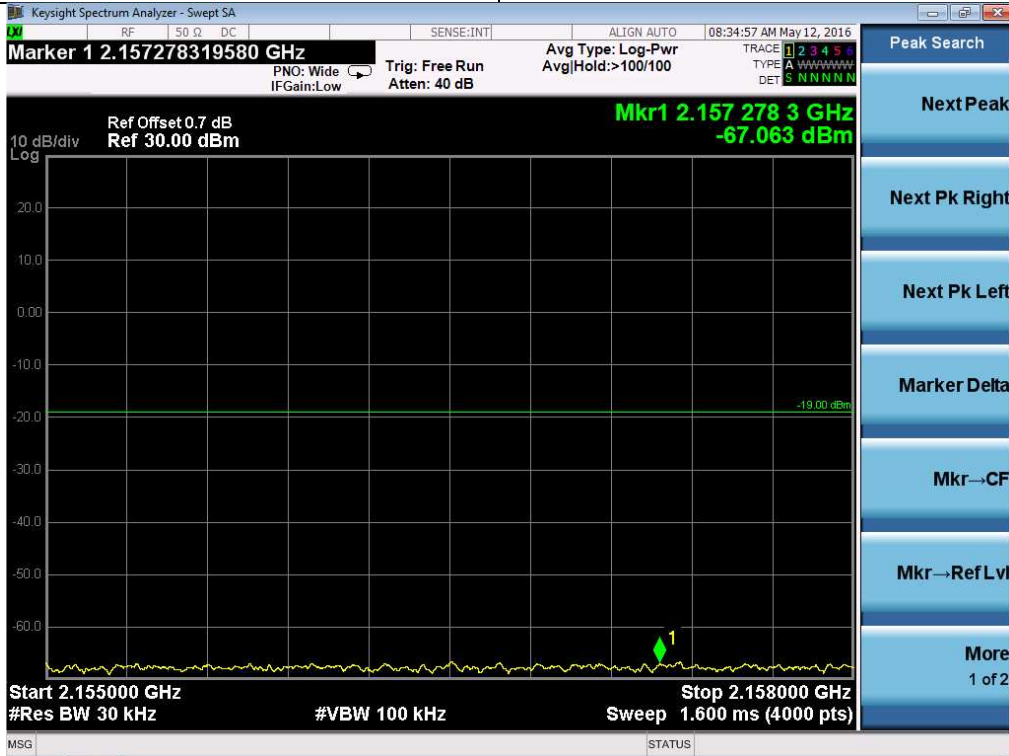

Downlink-L	2110-2155
------------	-----------

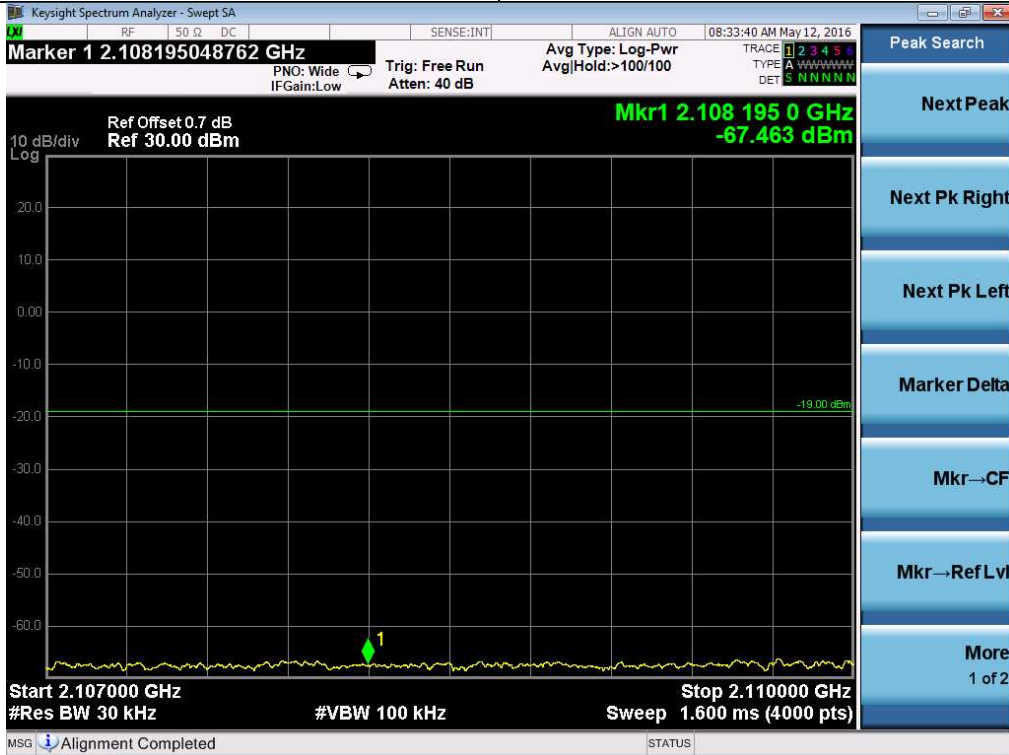

Downlink-H	869-894
------------	---------

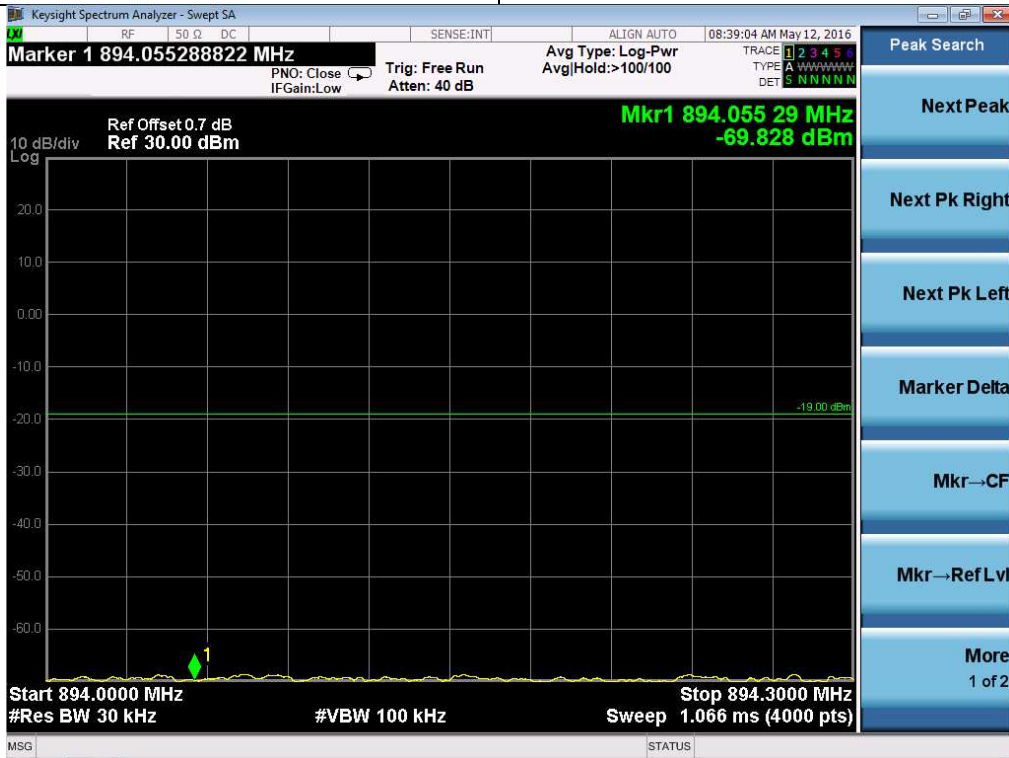

Downlink-L	869-894
------------	---------

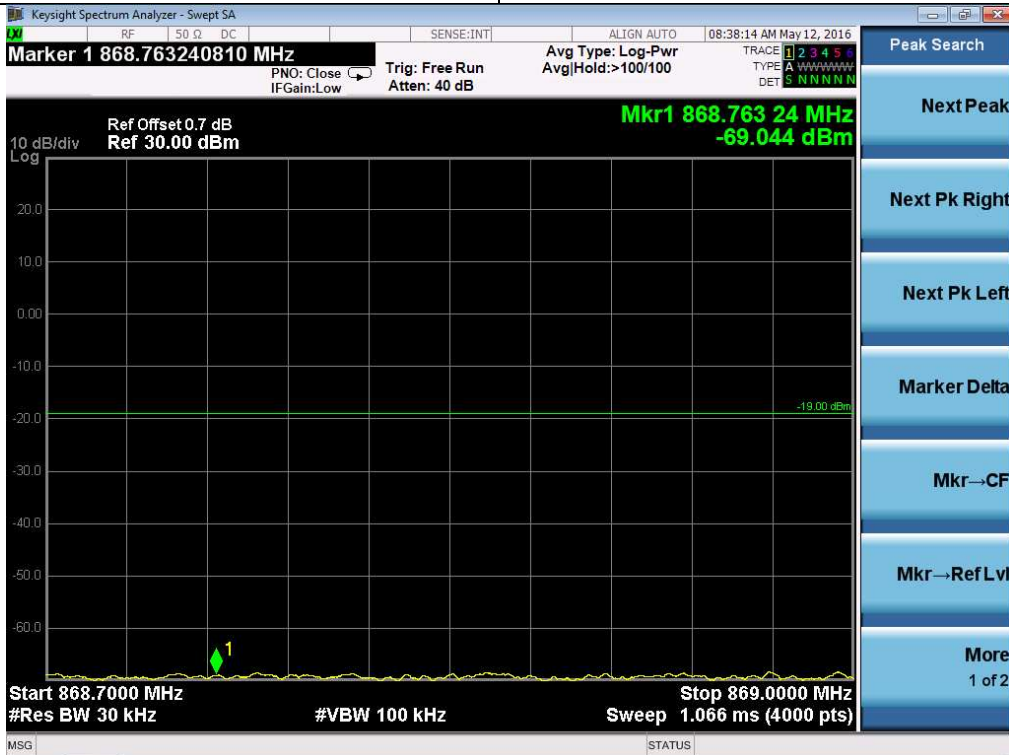

Downlink-H	746-757
------------	---------



Downlink-L	746-757
------------	---------

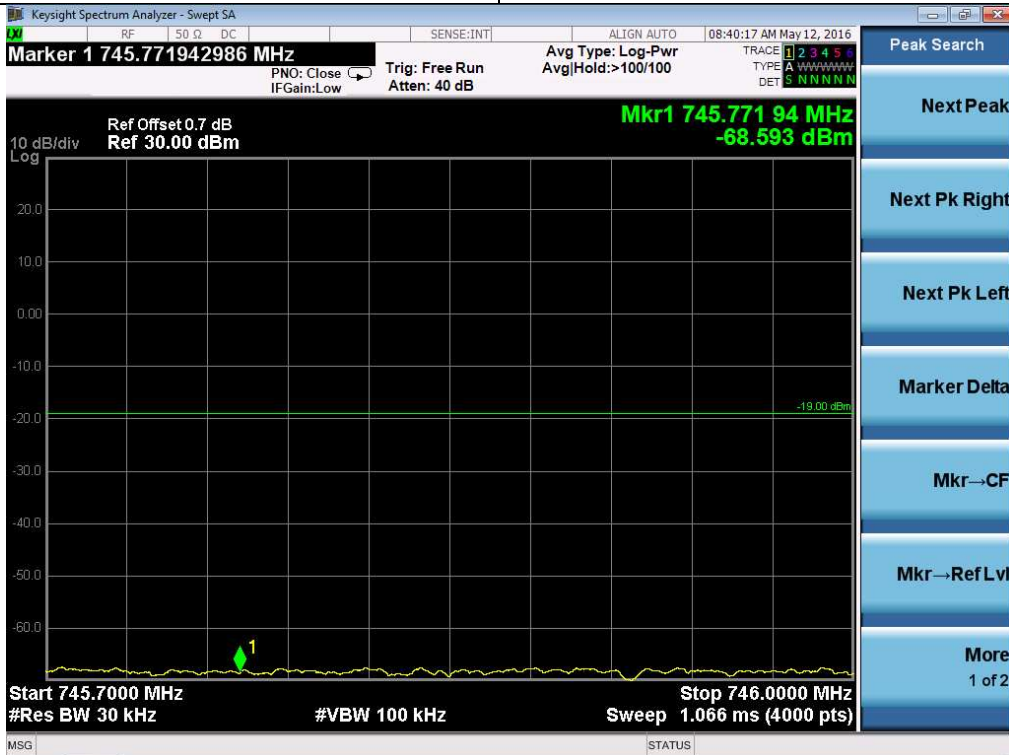

Downlink-H	734-746
------------	---------



Downlink-L	734-746
------------	---------

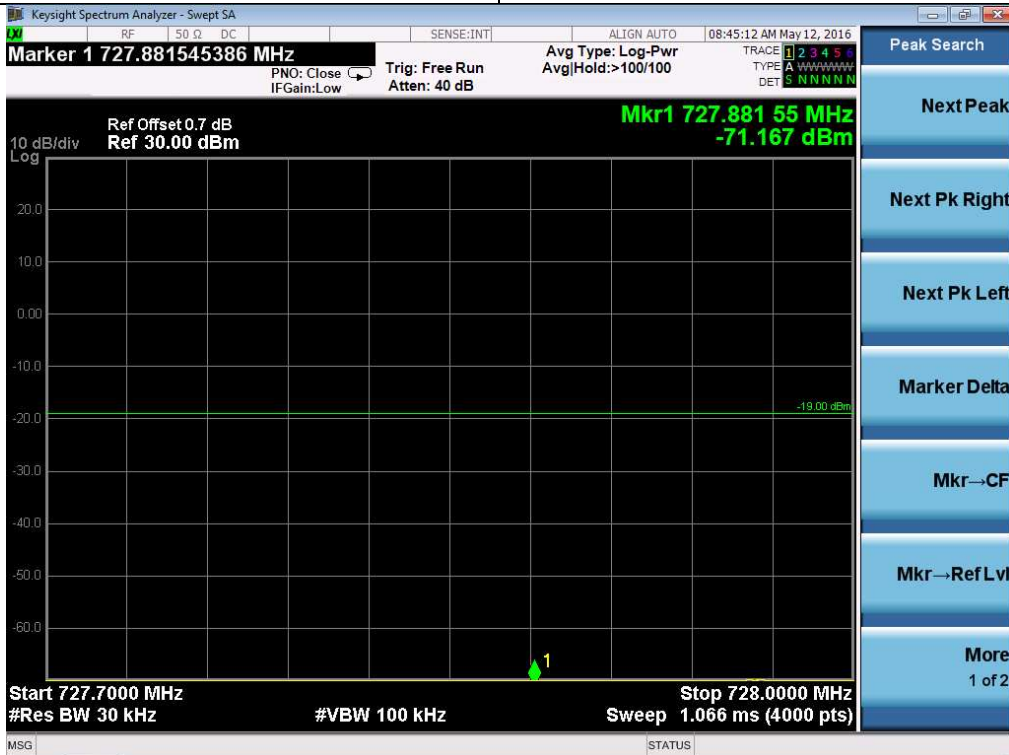

Downlink-H	1930-1990
------------	-----------

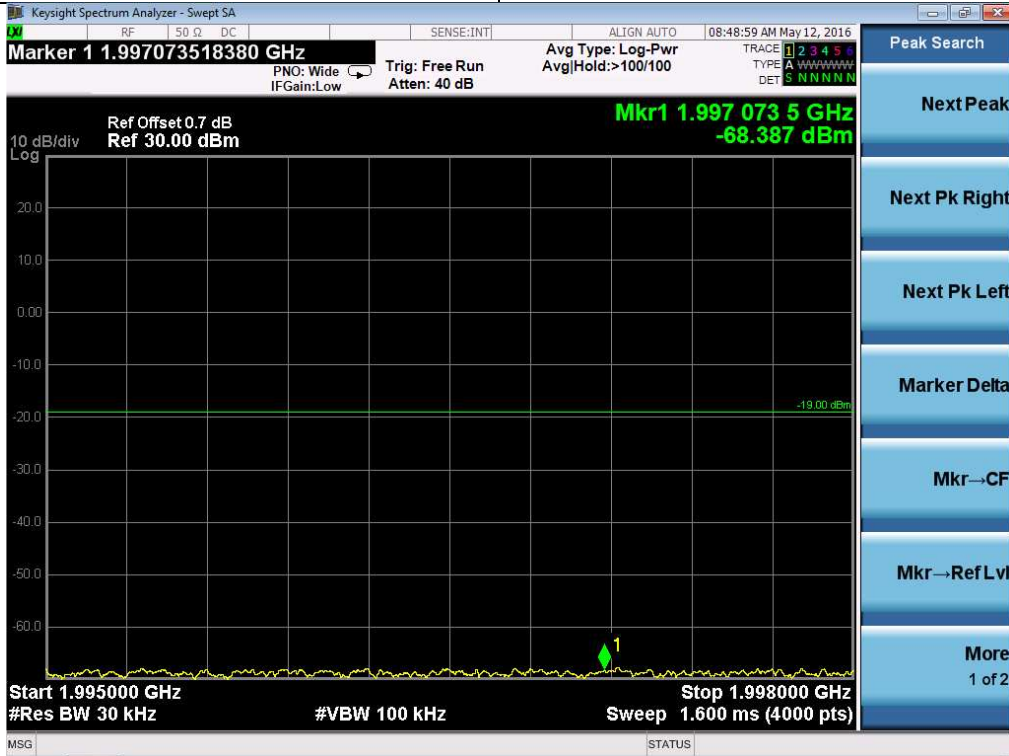

Downlink-L	1930-1990
------------	-----------

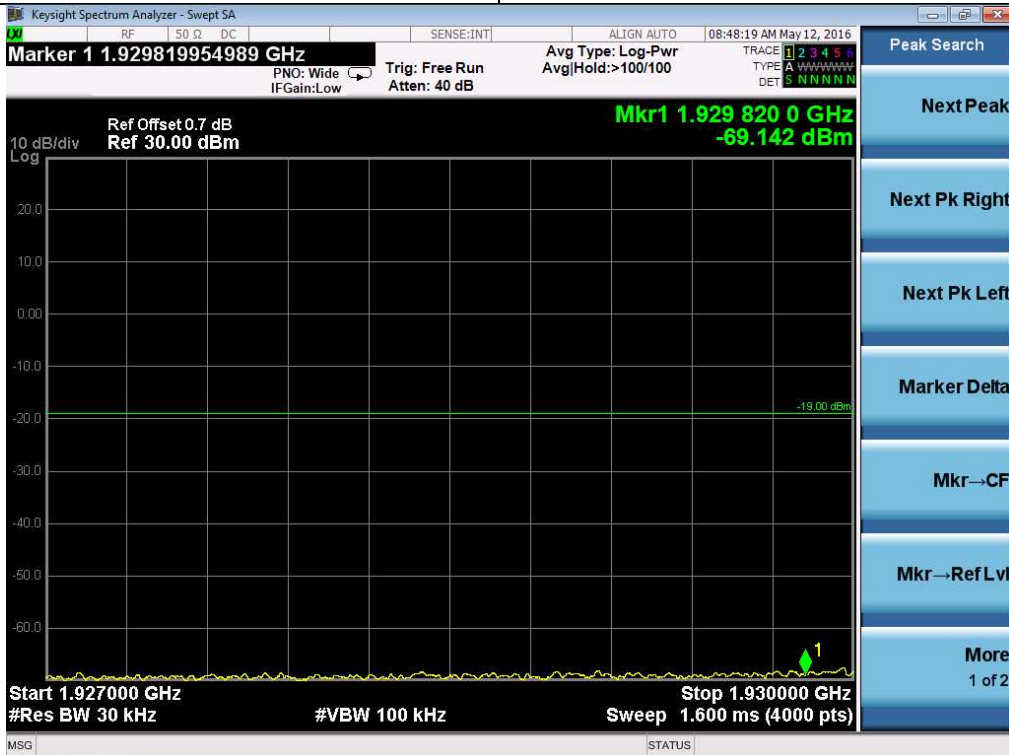

Signal Type	Mode	Band (MHz)	Max reading (dBm)	Limit (dBm)
GSM	Uplink-H	1710-1755	<-23	-19
	Uplink-L	1710-1755	<-23	
	Uplink-H	824-849	<-23	
	Uplink-L	824-849	<-23	
	Uplink-H	776-787	<-23	
	Uplink-L	776-787	<-23	
	Uplink-H	704-716	<-23	
	Uplink-L	704-716	<-23	
	Uplink-H	1850-1910	<-23	
	Uplink-L	1850-1910	<-23	
	Downlink-H	2110-2155	<-23	
	Downlink-L	2110-2155	<-23	
	Downlink-H	869-894	<-23	
	Downlink-L	869-894	<-23	
	Downlink-H	746-757	<-23	
	Downlink-L	746-757	<-23	
	Downlink-H	734-746	<-23	
	Downlink-L	734-746	<-23	
	Downlink-H	1930-1990	<-23	
	Downlink-L	1930-1990	<-23	

Uplink-H	1710-1755
----------	-----------

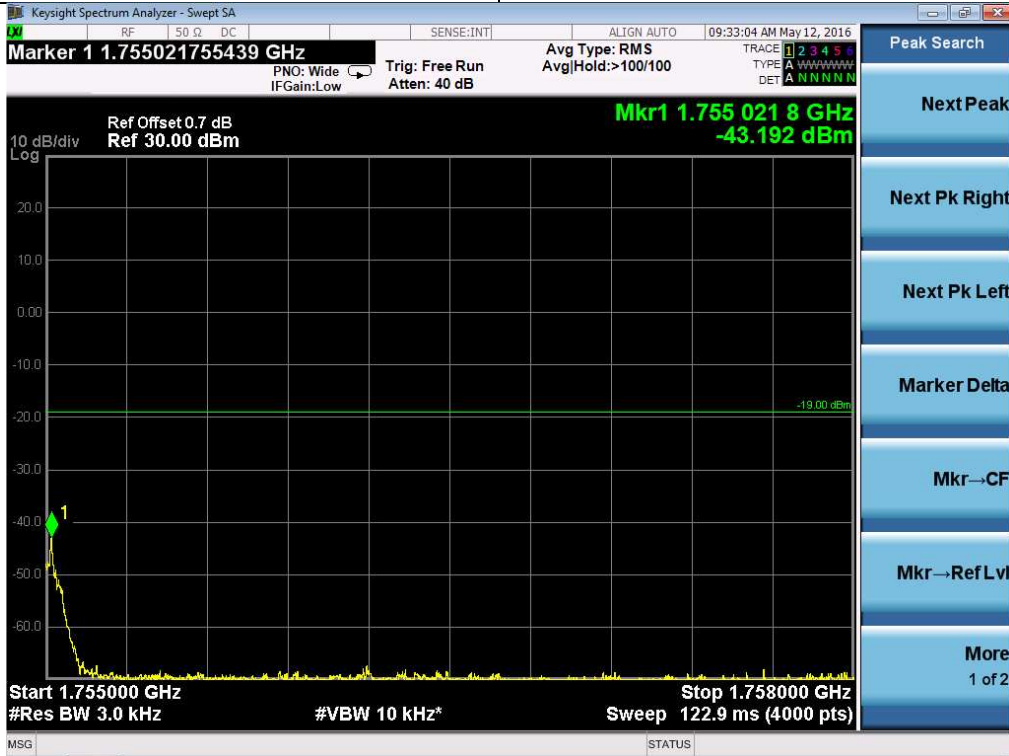

Uplink-L	1710-1755
----------	-----------

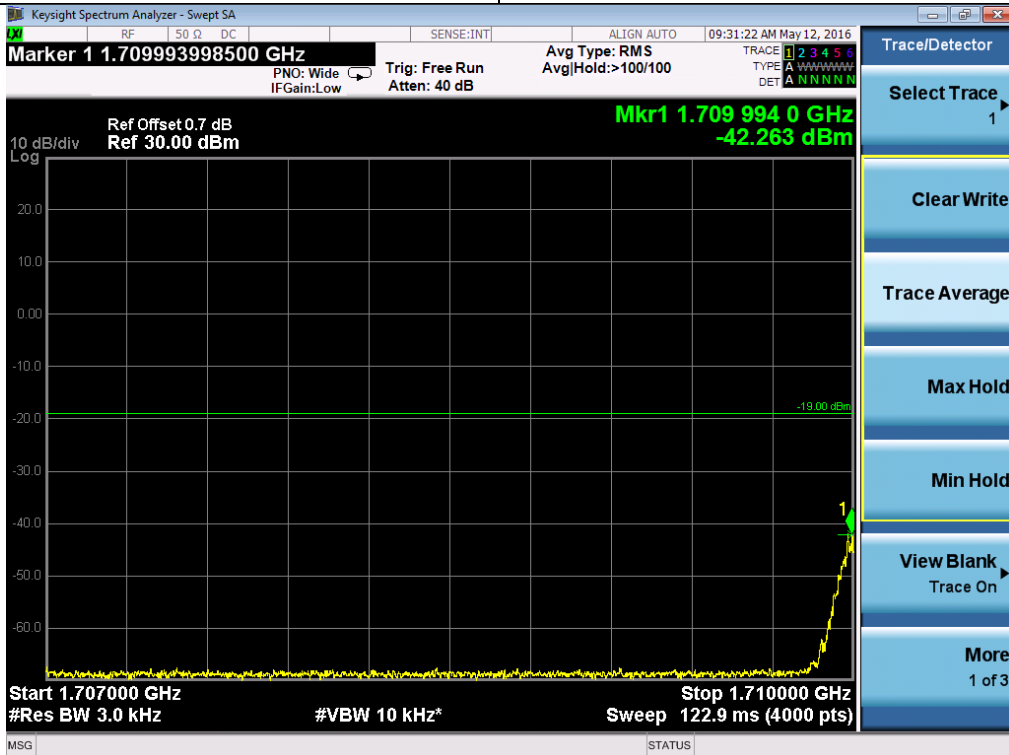

Uplink-H	824-849
----------	---------



Uplink-L	824-849
----------	---------

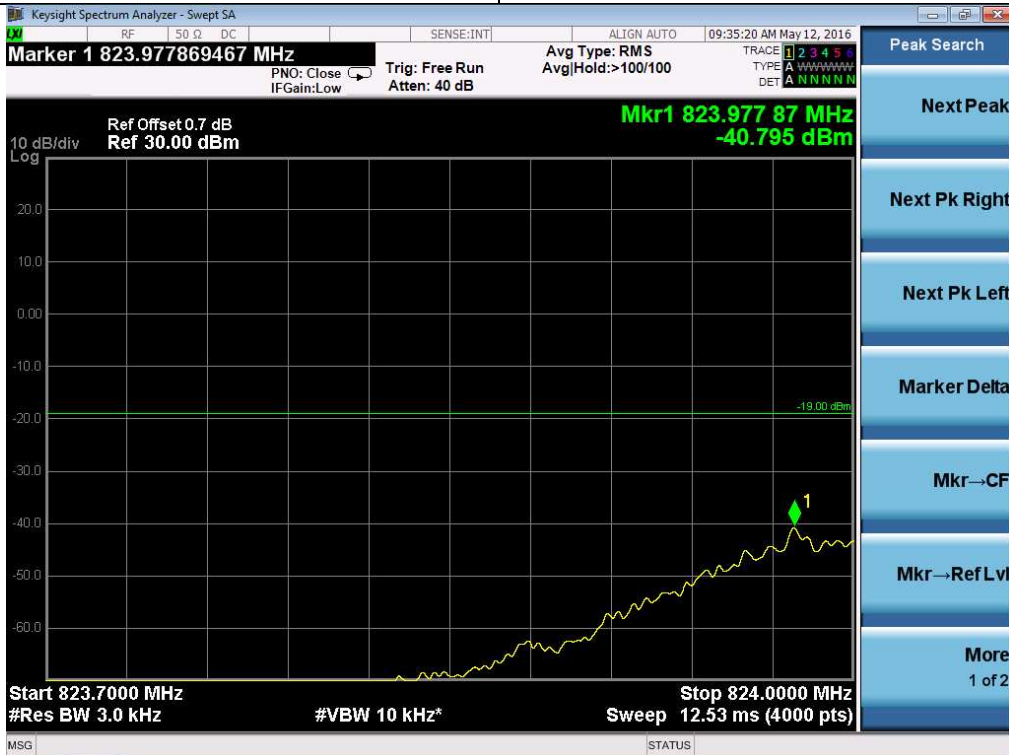

Uplink-H	776-787
----------	---------



Uplink-L	776-787
----------	---------



Uplink-H	704-716
----------	---------



Uplink-L	704-716
----------	---------

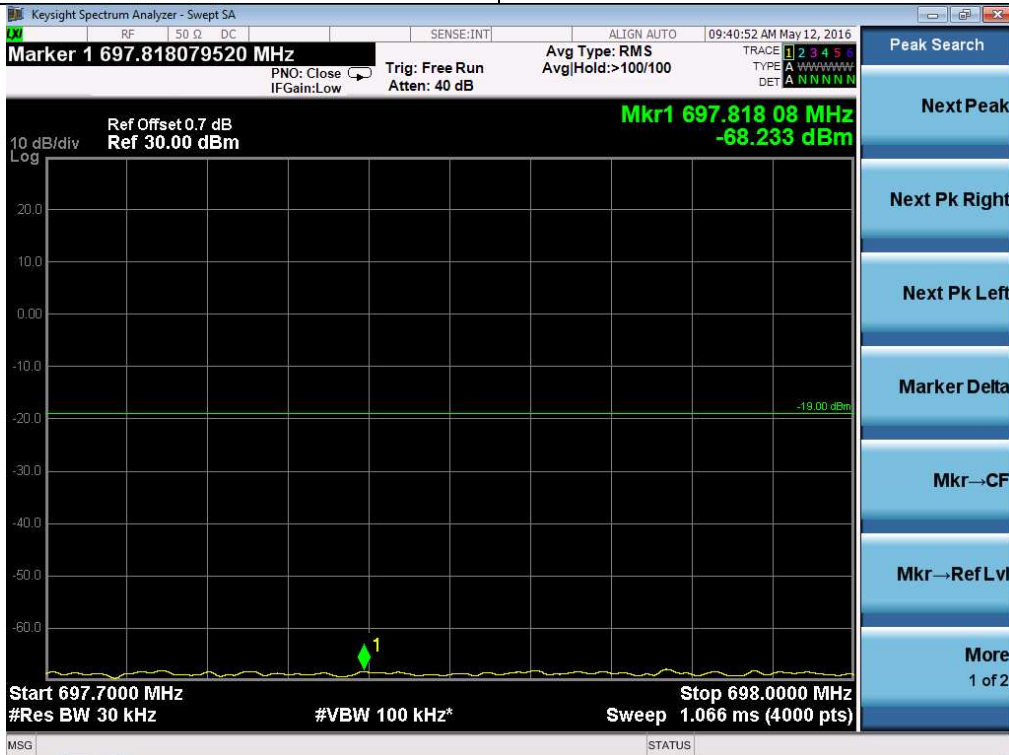

Uplink-H	1850-1910
----------	-----------

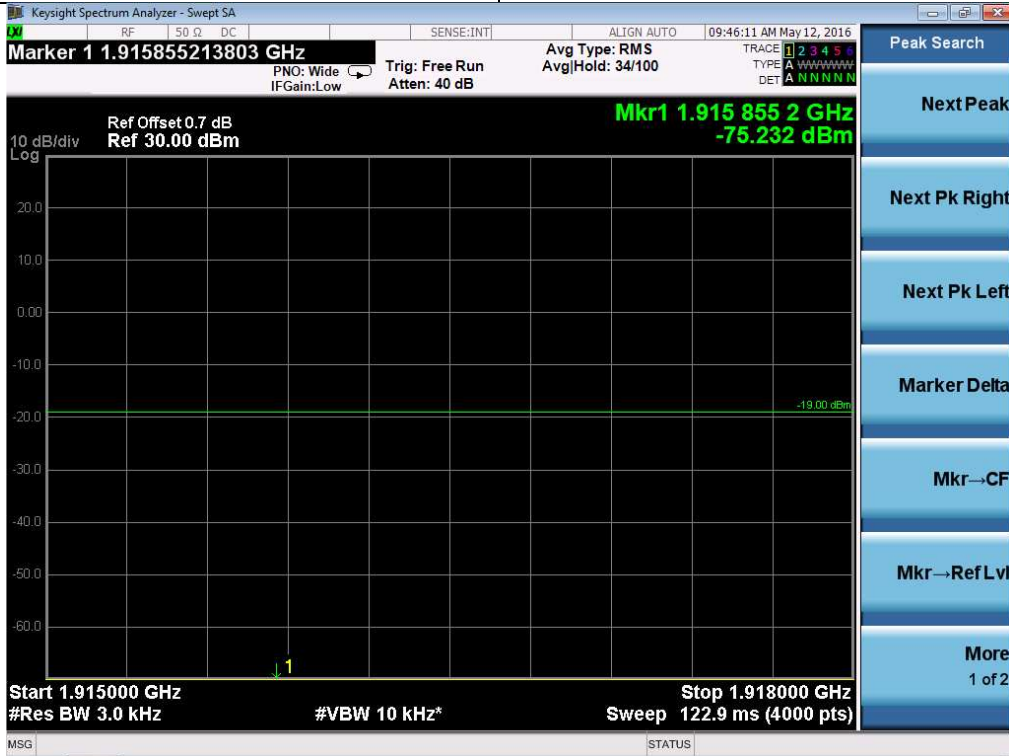

Uplink-L	1850-1910
----------	-----------

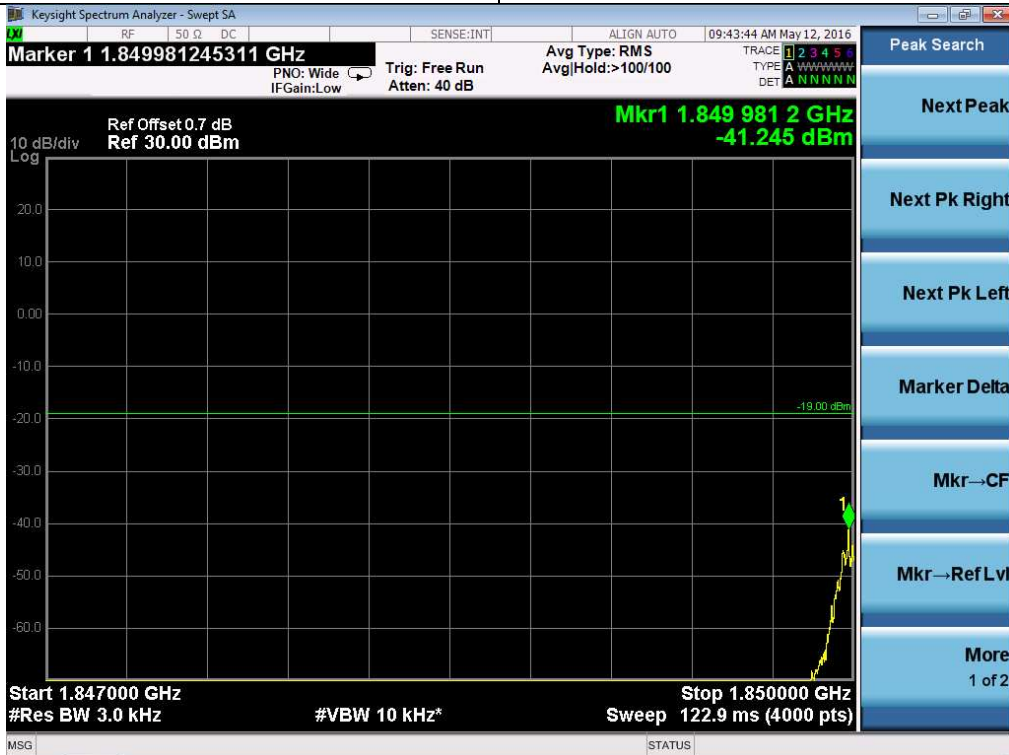

Downlink-H	2110-2155
------------	-----------

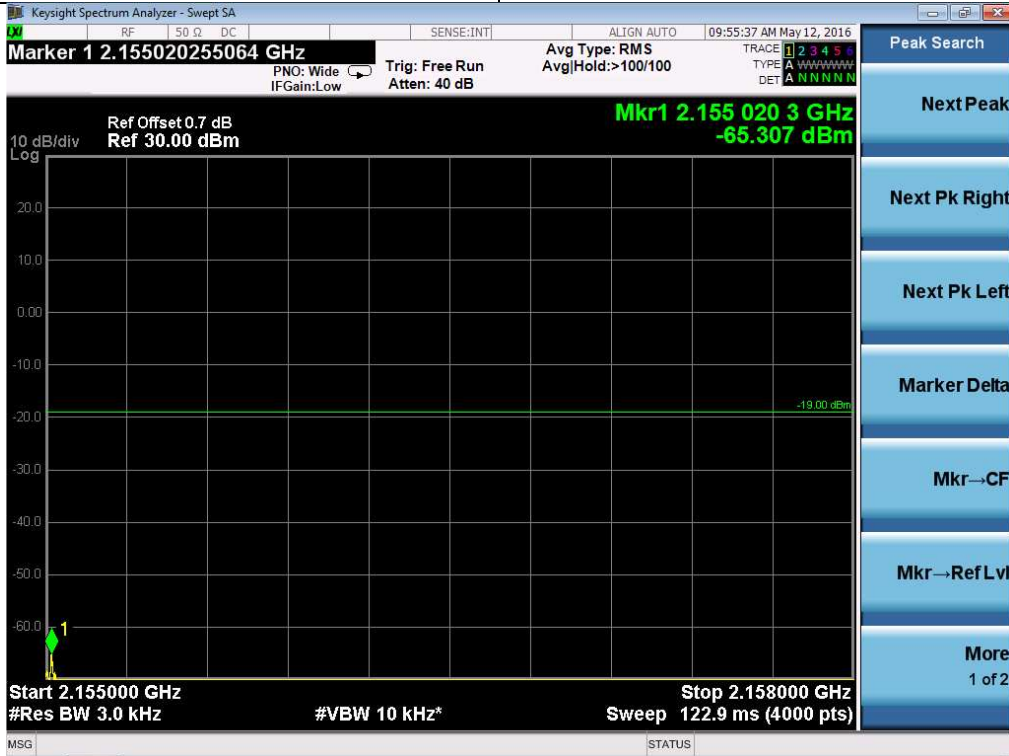

Downlink-L	2110-2155
------------	-----------

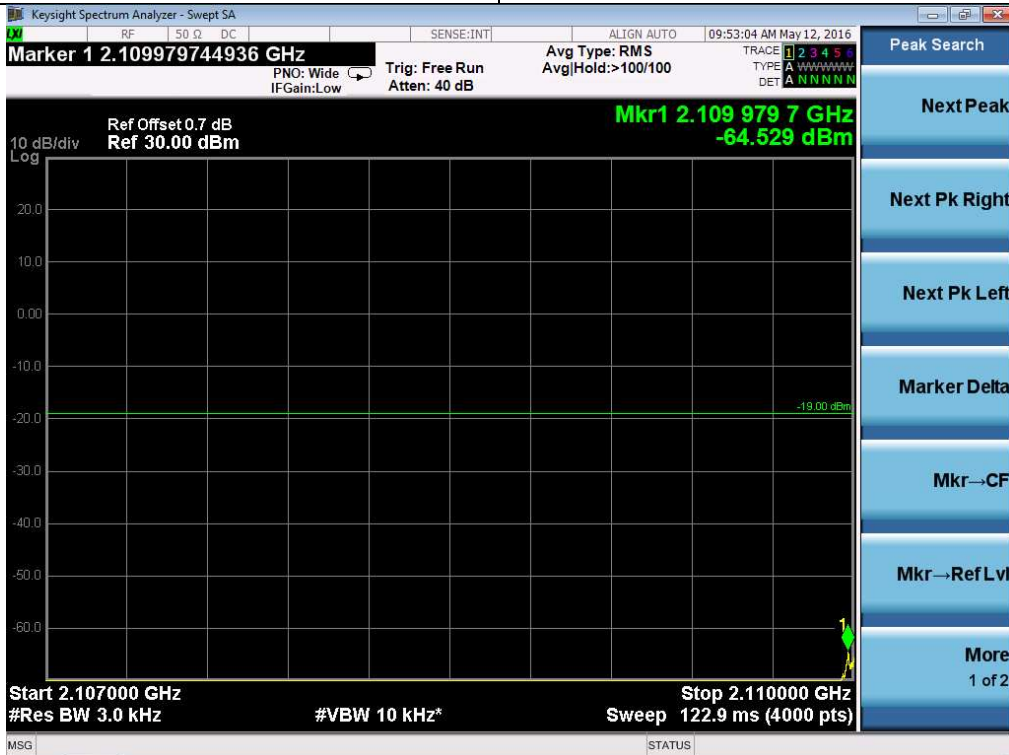

Downlink-H	869-894
------------	---------

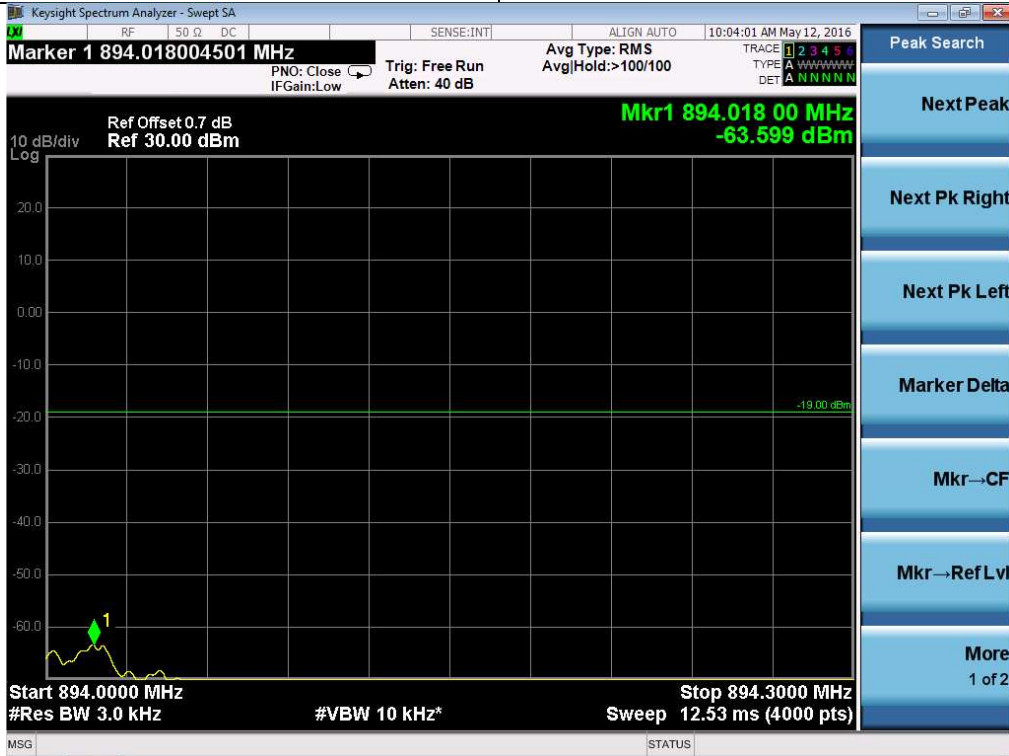

Downlink-L	869-894
------------	---------

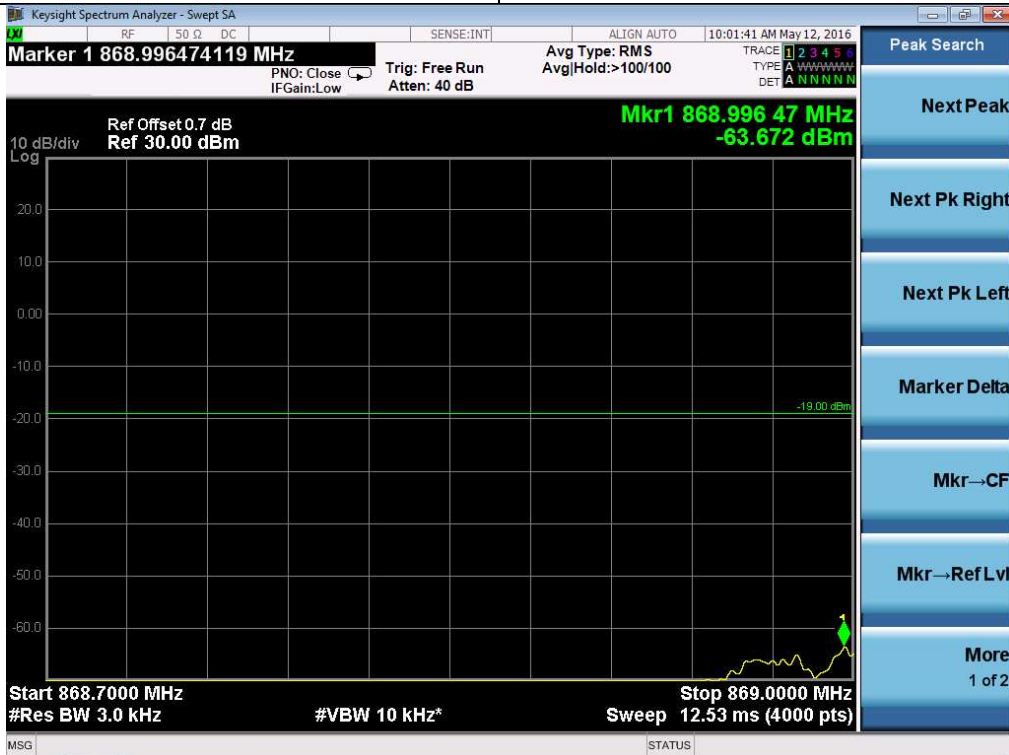

Downlink-H	746-757
------------	---------



Downlink-L	746-757
------------	---------

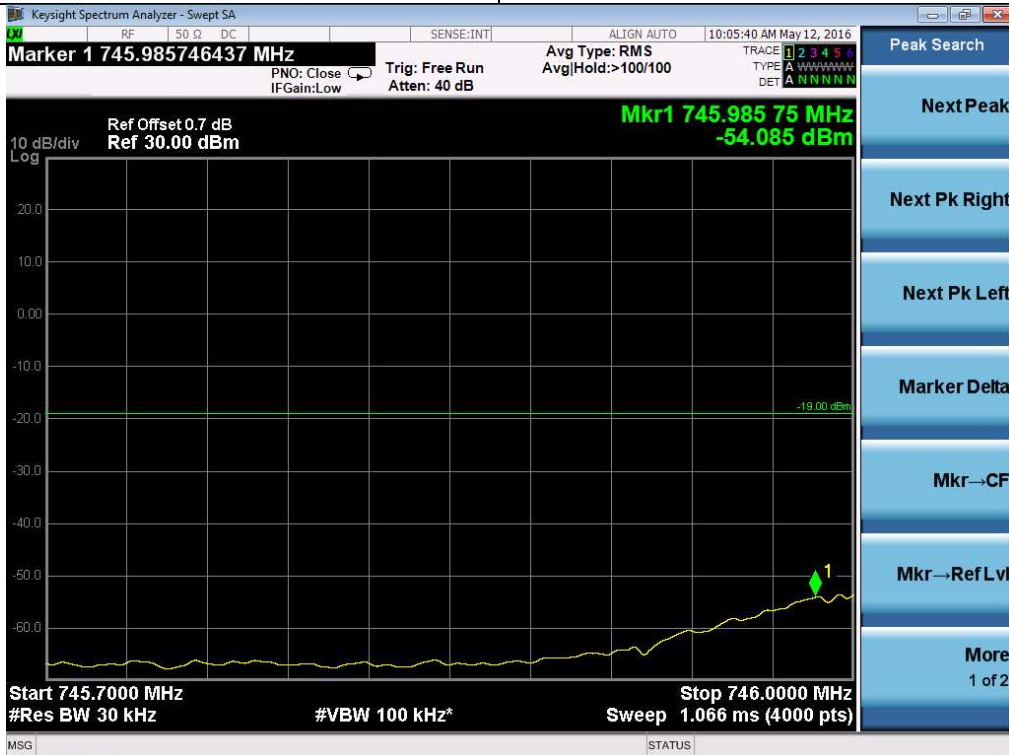

Downlink-H	734-746
------------	---------



Downlink-L	734-746
------------	---------

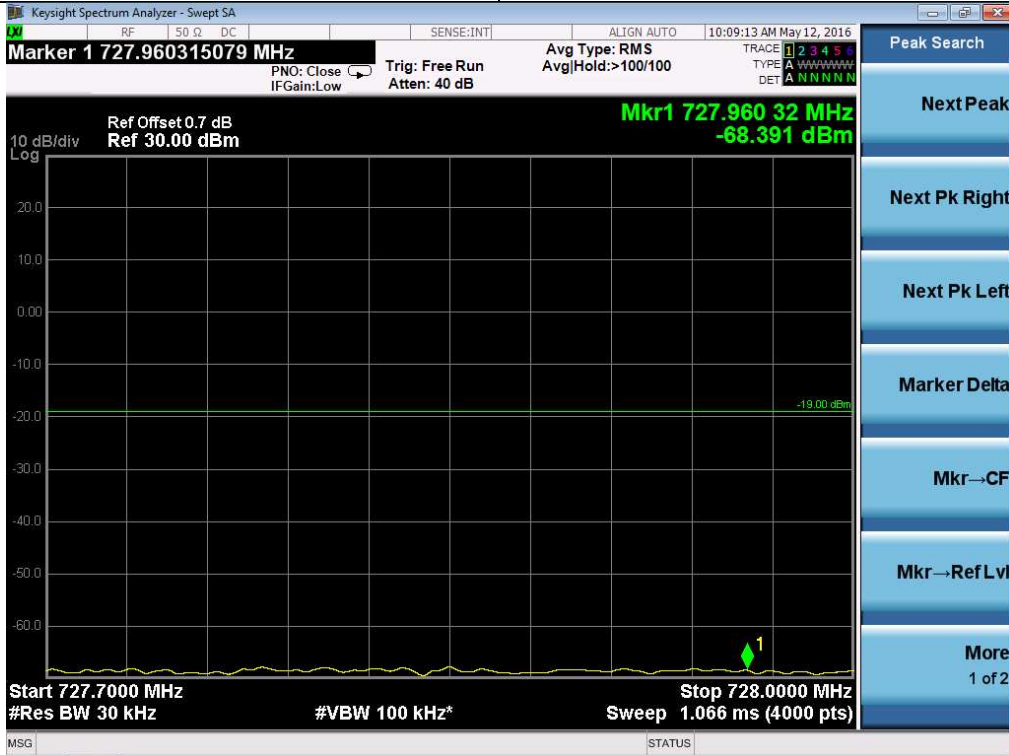

Downlink-H	1930-1990
------------	-----------

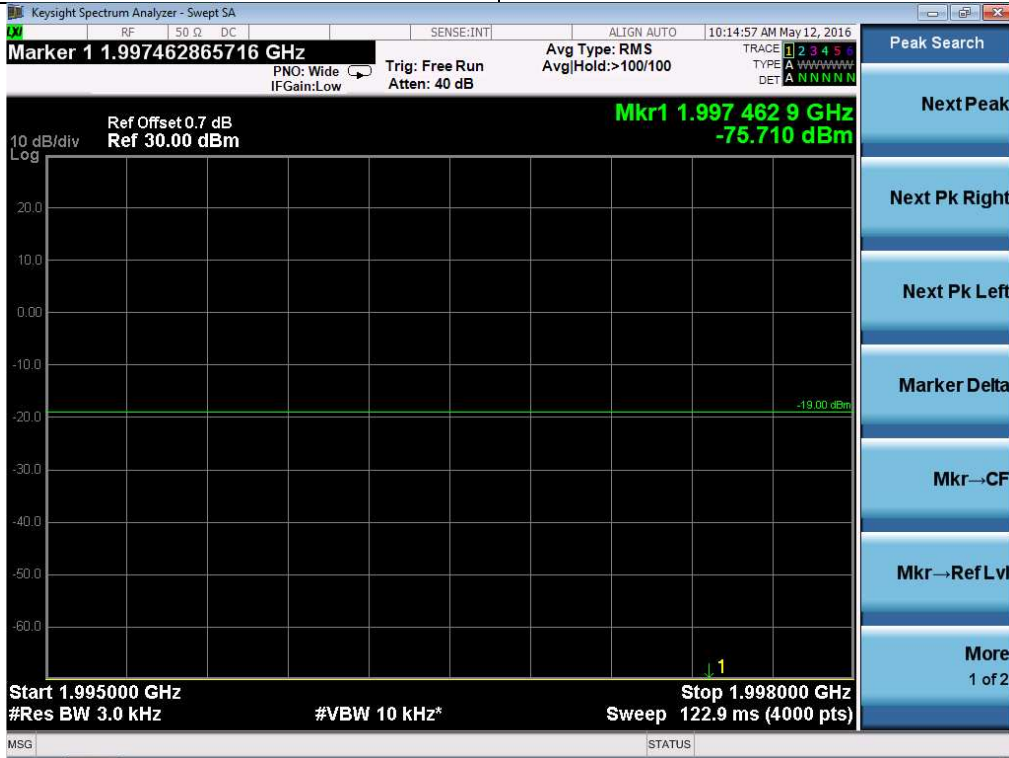

Downlink-L	1930-1990
------------	-----------

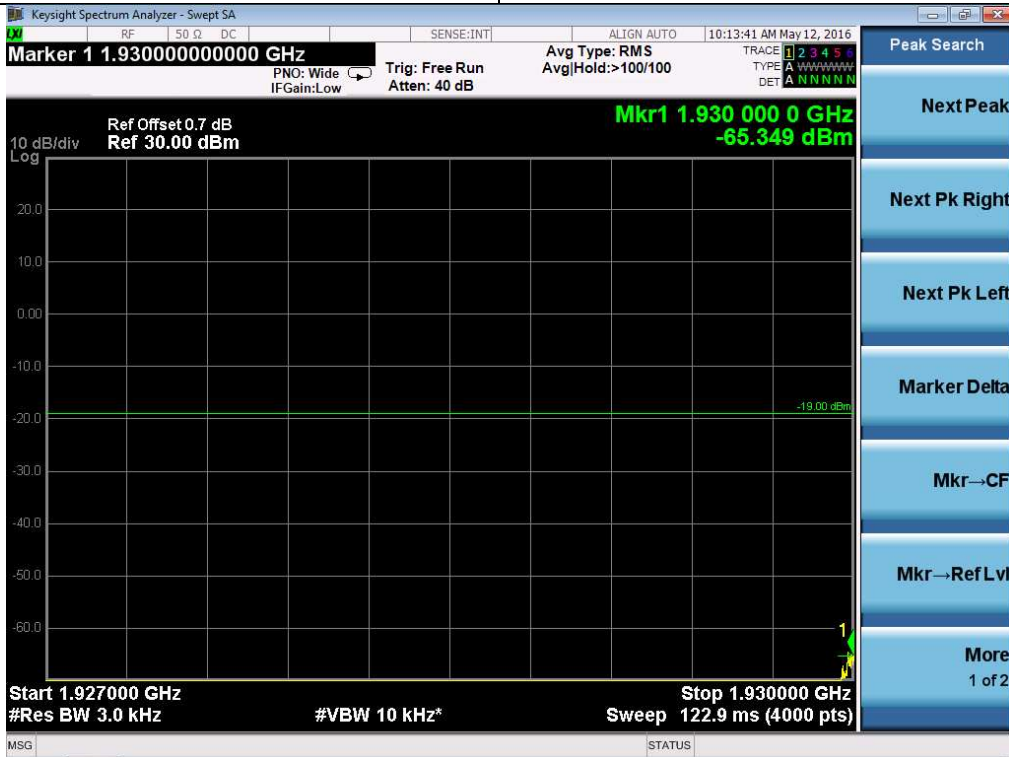

Signal Type	Mode	Band (MHz)	Max reading (dBm)	Limit (dBm)
LTE	Uplink-H	1710-1755	<-23	-19
	Uplink-L	1710-1755	<-23	
	Uplink-H	824-849	<-23	
	Uplink-L	824-849	<-23	
	Uplink-H	776-787	<-23	
	Uplink-L	776-787	<-23	
	Uplink-H	704-716	<-23	
	Uplink-L	704-716	<-23	
	Uplink-H	1850-1910	<-23	
	Uplink-L	1850-1910	<-23	
	Downlink-H	2110-2155	<-23	
	Downlink-L	2110-2155	<-23	
	Downlink-H	869-894	<-23	
	Downlink-L	869-894	<-23	
	Downlink-H	746-757	<-23	
	Downlink-L	746-757	<-23	
	Downlink-H	734-746	<-23	
	Downlink-L	734-746	<-23	
	Downlink-H	1930-1990	<-23	
	Downlink-L	1930-1990	<-23	

Uplink-H	1710-1755
----------	-----------

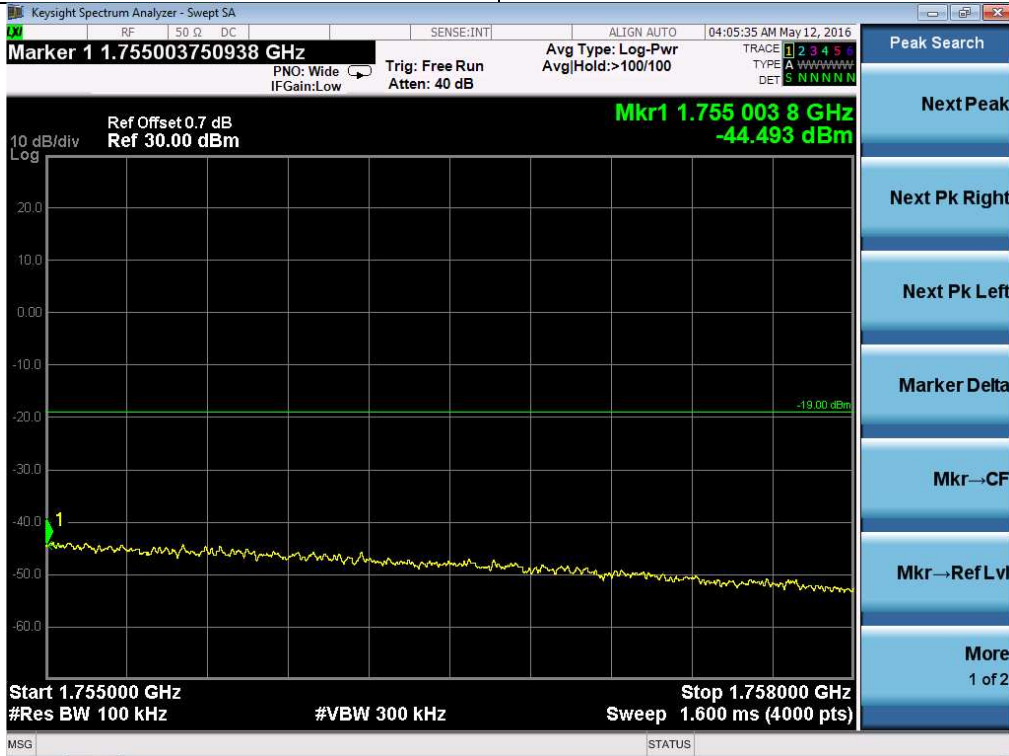

Uplink-L	1710-1755
----------	-----------

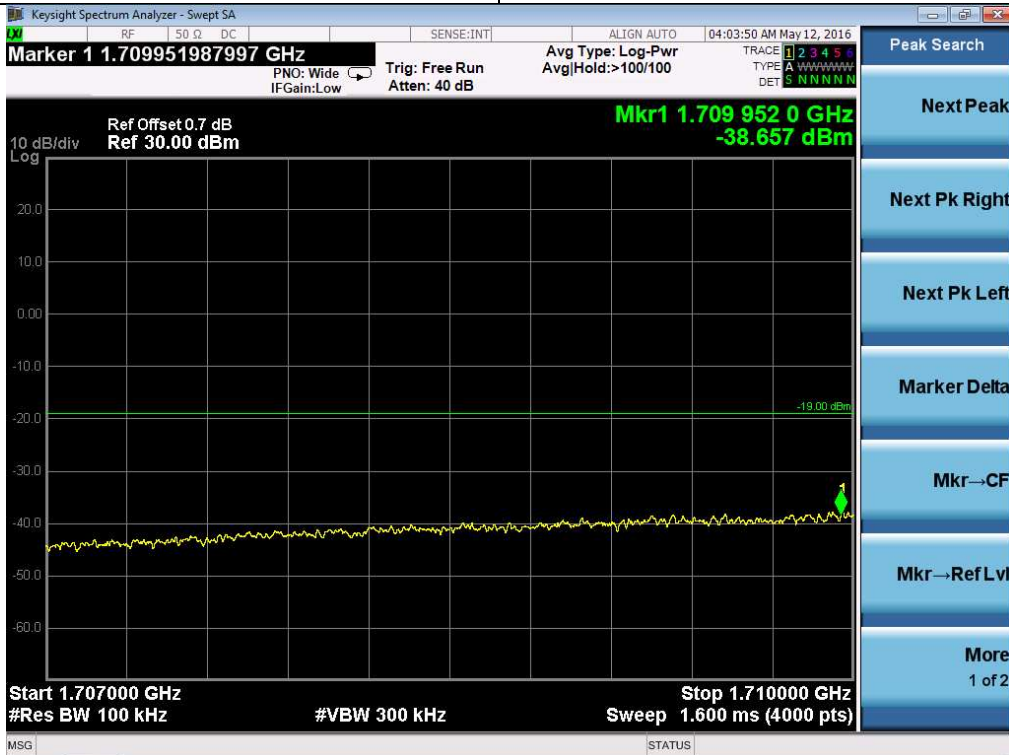

Uplink-H	824-849
----------	---------

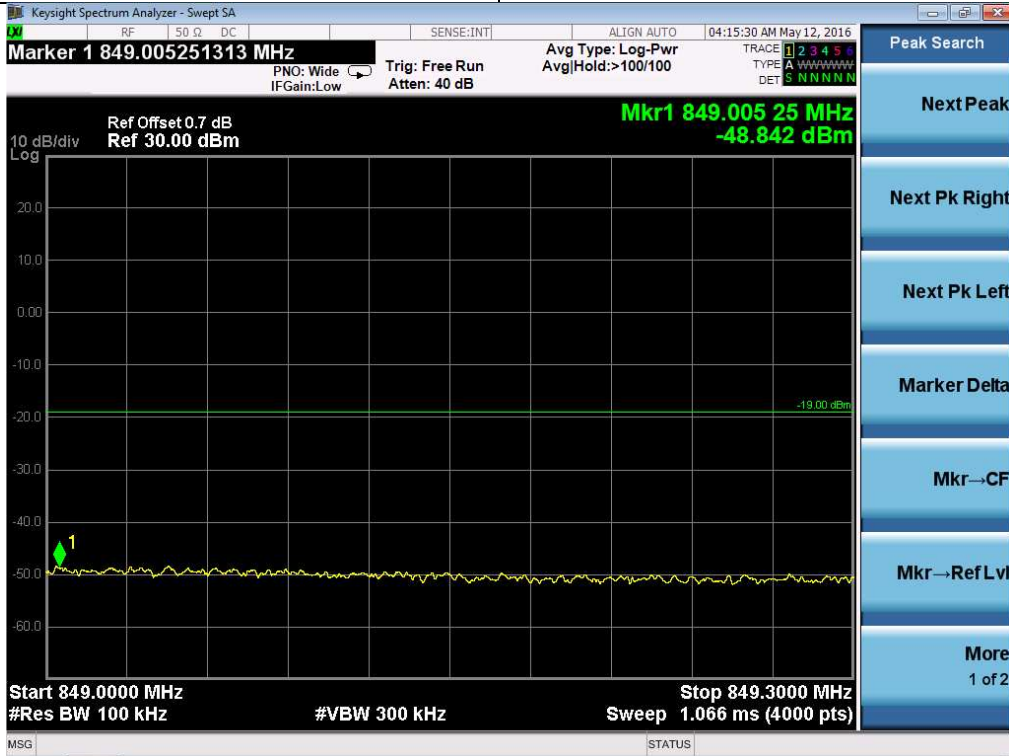

Uplink-L	824-849
----------	---------

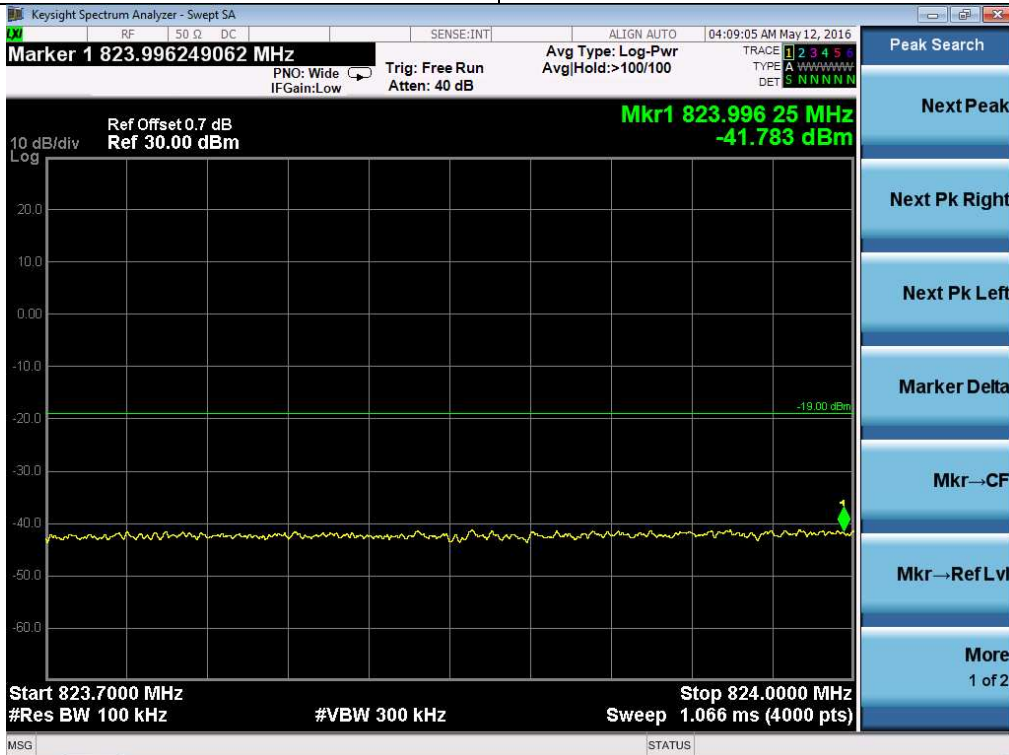

Uplink-H	776-787
----------	---------

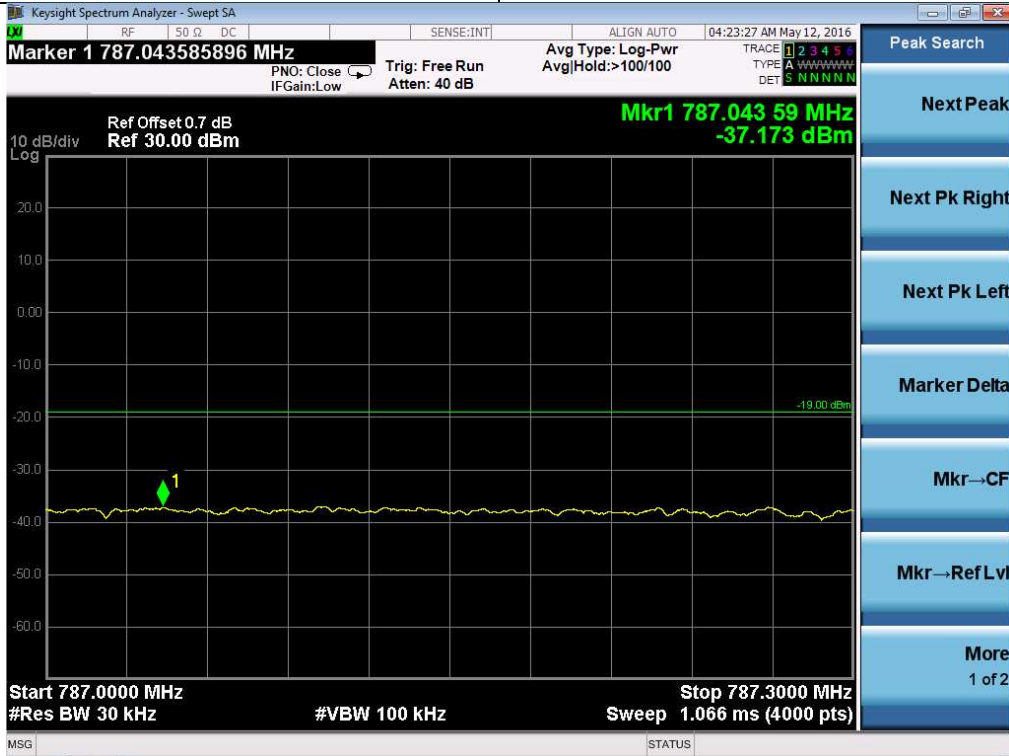

Uplink-L	776-787
----------	---------

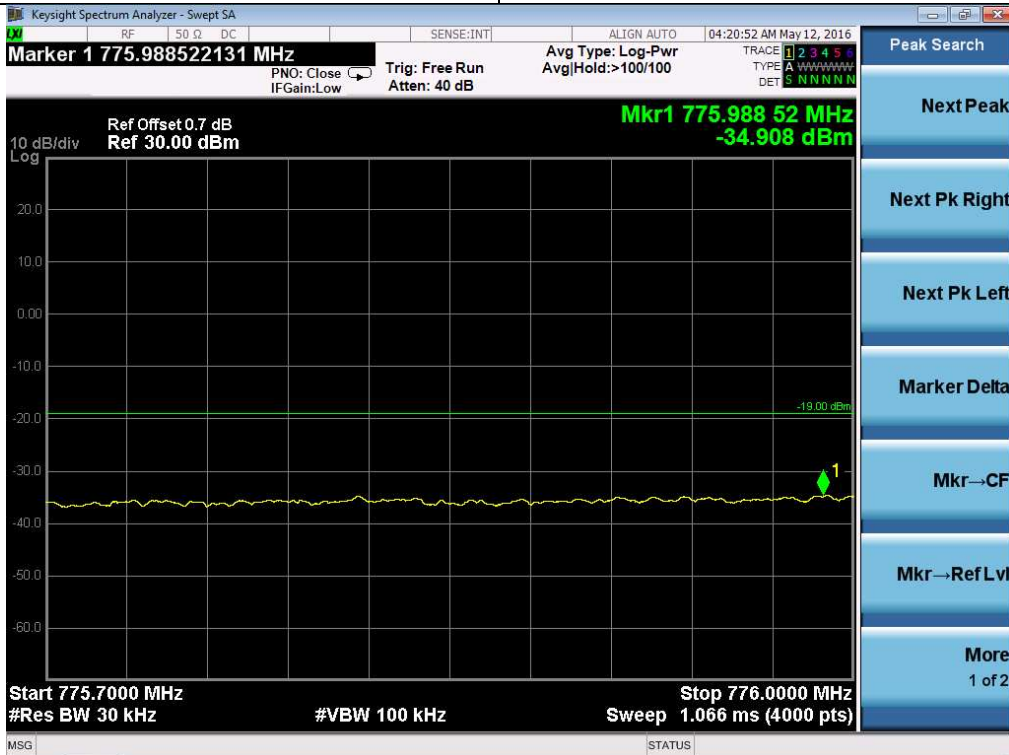

Uplink-H	704-716
----------	---------

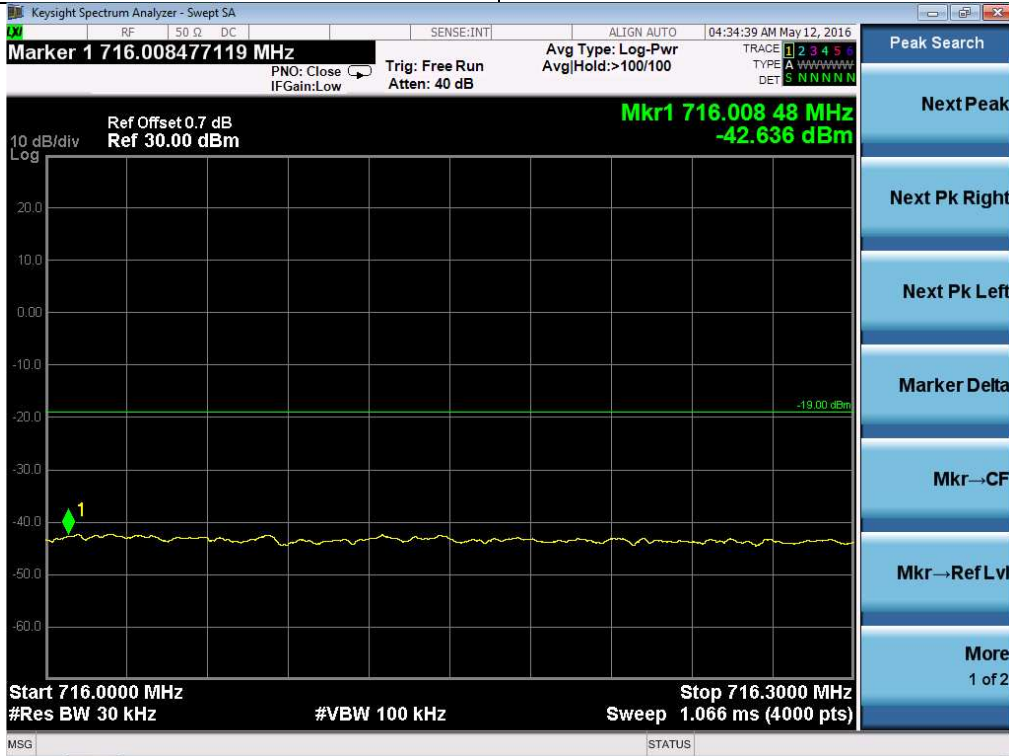

Uplink-L	704-716
----------	---------

