

FCC PART 22H /24E TEST REPORT

Applicant : Shanghai Tigercel Communication Technologies Corp.
Address : Room 810, building 1, No. 100 Qinzhou Road, Xuhui District, Shanghai, China P.C: 200235
Manufacturer : Shanghai Tigercel Communication Technologies Corp.
Address : Room 810, building 1, No. 100 Qinzhou Road, Xuhui District, Shanghai, China P.C: 200235
Factory : Shanghai Tigercel Communication Technologies Corp.
Address : Room 810, building 1, No. 100 Qinzhou Road, Xuhui District, Shanghai, China P.C: 200235
E.U.T. : GSM Wireless Data Terminal
Brand Name : N/A
Model No. : IF862
Measurement Standard : FCC PART 22H
FCC PART 24E
FCC ID : 2AIGX-2016IF862
Date of Receiver : April 29, 2016
Date of Test : April 29, 2016 to May 11, 2016
Date of Report : May 12, 2016

This Test Report is Issued Under the Authority of :

Prepared by

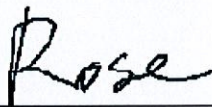

Rose Hu / Engineer

Approved & Authorized Signer



Note: This test report is for the customer shown above and their specific product only. It may not be duplicated or used in part without prior written consent from Dongguan Nore Testing Center Co., Ltd. The test results referenced from this report are relevant only to the sample tested.



Table of Contents

1. GENERAL INFORMATION	4
1.1 PRODUCT DESCRIPTION FOR EQUIPMENT UNDER TEST	4
1.2 RELATED SUBMITTAL(S) / GRANT (S)	6
1.3 TEST METHODOLOGY	6
1.4 EQUIPMENT MODIFICATIONS	6
1.5 SUPPORT DEVICE	6
1.6 TEST FACILITY AND LOCATION.....	6
1.7 SUMMARY OF TEST RESULTS.....	7
2. RF OUTPUT POWER.....	8
2.1 APPLICABLE STANDARD	8
2.2 TEST PROCEDURE	8
3. TEST OCCUPIED BANDWIDTH.....	12
3.1 APPLICABLE STANDARD	12
3.2 TEST PROCEDURE	12
4. FREQUENCY STABILITY.....	20
4.1 APPLICABLE STANDARD	20
4.2 TEST PROCEDURE	20
5. BAND EDGES.....	23
5.1 APPLICABLE STANDARD	23
5.2 TEST PROCEDURE	23
6. MODULATION CHARACTERISTIC.....	27
7. SPURIOUS EMISSIONS AT ANTENNA TERMINALS	28
7.1 APPLICABLE STANDARDS	28
7.2 TEST PROCEDURE	28
8. FIELD STRENGTH OF SPURIOUS RADIATED EMISSIONS.....	35
8.1 APPLICABLE STANDARDS	35
8.2 TEST OF BLOCK DIAGRAM OF CONFIGURATION.....	35
8.3 TEST PROCEDURE	36
9. RF EXPOSURE	39
9.1 APPLICABLE STANDARDS	39
9.2 TEST RESULT.....	39
10. TEST EQUIPMENT LIST.....	40

1. GENERAL INFORMATION

1.1 Product Description for Equipment under Test

Product Name	: GSM Wireless Data Terminal
Model name	: IF682
Model Difference Description	: N/A
Power Supply	: Li-lithium Battery 3.8V 450mAh DC 5V come from external USB Port
Hardware Version	: A9188_A13
Software Version	: SW_A9188_S6385_L100_V165_TIGERCEL_CTA
Frequency Range	: Cellular Band: 824.2-848.8MHz (TX) 869.2-893.8MHz(RX) PCS Band: 1850.2-1909.8MHz (TX) 1930.2-1989.8MHz(RX) Bluetooth: 2402-2480MHz
Modulation	: GMSK for GSM/PCS GFSK for Bluetooth
GPRS Multi-slot class	: 8/10/12
Antenna Type	: Integral
Antenna Gain	: 1.4dBi for GSM850 2.2dBi for PCS1900 -5.6dBi for Bluetooth
Number of Channels	: 299 for GSM850 124 for PCS1900 40 for Bluetooth
Maximum Output Power to Antenna	: GSM850: 31.8dBm PCS1900: 28.34dBm
Note	: This measurement and test report only pertains to the GSM portion of the EUT. For measurement and test results to the Bluetooth functions please refer to report number NTC1604341F.



Test channel and frequency

GSM850		PCS1900	
Channel	Frequency MHz	Channel	Frequency MHz
128	824.2	512	1850.2
189	836.4	661	1880.0
251	848.8	810	1909.8

1.2 Related Submittal(s) / Grant (s)

This submittal(s) test report is filing to comply with Section Part 22 subpart H and Part 24 subpart E of the FCC CFR47 Rules.

1.3 Test Methodology

Both conducted and radiated testing were performed according to the procedures document to TIA/EIA 603 and FCC CFR 47.1046, 2.1047, 2.1049, 2.1051, 2.1053, 2.1055 and 2.1057

1.4 Equipment Modifications

Not available for this EUT intended for grant.

1.5 Support Device

N/A

1.6 Test Facility and Location

Listed by FCC, August 02, 2011
The Certificate Registration Number is 665078.

Listed by Industry Canada, July 01, 2011
The Certificate Registration Number is 46405-9743.

Dongguan NTC Co., Ltd.

Building D, Gaosheng Science and Technology Park,
Hongtu Road, Nancheng District, Dongguan City,
Guangdong Province, China



1.7 Summary of Test Results

FCC Rules	Description Of Test	Result
§2.1046 §22.913(a) §24.232(c)	RF Output Power	Compliant
§ 2.1049 § 22.905 § 22.917 § 24.238	Occupied Bandwidth	Compliant
§ 2.1055 § 22.355 § 24.235	Frequency stability vs. temperature Frequency stability vs. voltage	Compliant
§ 22.917 (a) § 24.238 (a)	Out of band emission, Band Edge	Compliant
§ 2.1047	Modulation Characteristics	N/A
§ 2.1051 § 22.917 (a) § 24.238 (a)	Spurious Emissions at Antenna Terminal	Compliant
§ 2.1053 § 22.917 (a) § 24.238 (a)	Field Strength of Spurious Radiation	Compliant
§1.1307, §2.1093	RF Exposure (SAR)	Compliant(refer to SAR report please)

Note: The full charge battery used during the test.

2. RF OUTPUT POWER

2.1 Applicable Standard

According to FCC §2.1046 and §22.913 (a), the ERP of mobile transmitters and auxiliary test transmitters must not exceed 7 watts.

According to FCC §2.1046 and §24.232 (C), in no case may the peak output power of a base station transmitter exceed 2 watt EIRP.

2.2 Test Procedure

Conducted Method:

The transmitter output was connected to a calibrated attenuator, the other end of which was connected to a spectrum analysis. Transmitter output was read off the spectrum analysis in dBm. The power output at the transmitter antenna port was determined by adding the value of the attenuator to spectrum analysis reading.

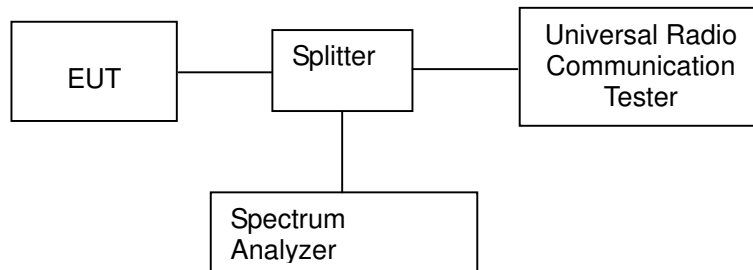

Radiated method:

The EUT was placed on an non-conductive turntable using a non-conductive support. The radiated emission at the fundamental frequency was measured at 3 m with a test antenna and EMI spectrum analyzer. During the measurement, the EUT was communication with the station. The highest emission was recorded with the rotation of the turntable and the lowering of the test antenna from 1m to 4m. The reading was recorded and the field strength (E in dBuV/m) was calculated. ERP in frequency band 824.2 –848.80.8MHz were measured using a substitution method. The EUT was replaced by dipole antenna connected, the S.G. output was recorded and ERP was calculated as follows: EIRP in frequency band 1850.2 –1909.8MHz were measured using a substitution method. The EUT was replaced by or horn antenna connected, the S.G. output was recorded and EIRP was calculated as follows: $ERP = S.G. \text{ output (dBm) + Antenna Gain (dBd) - Cable Loss (dB)}$ $EIRP = S.G. \text{ output (dBm) + Antenna Gain (dBi) - Cable Loss (dB)}$

Radiated Emission Test Set-Up, Frequency Below 1000MHz

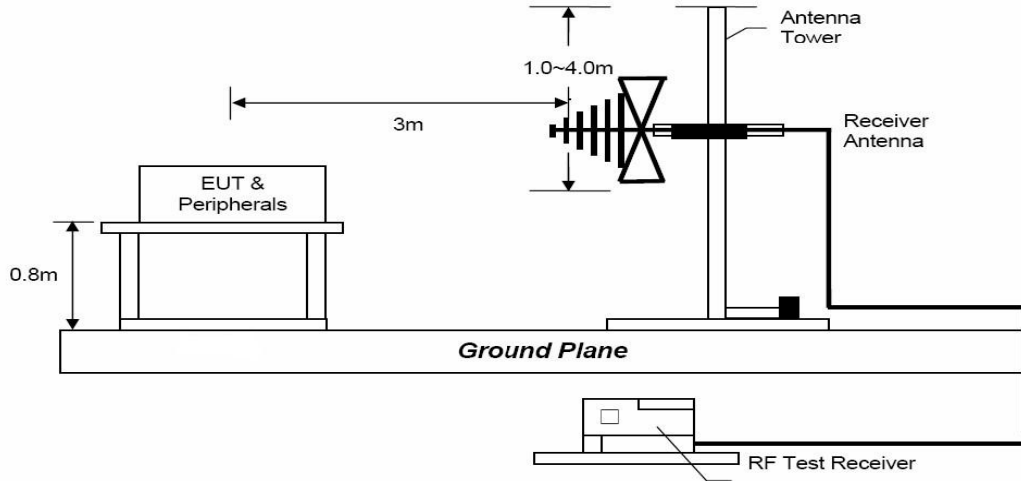

Radiated Emission Test Set-Up, Frequency above 1GHz

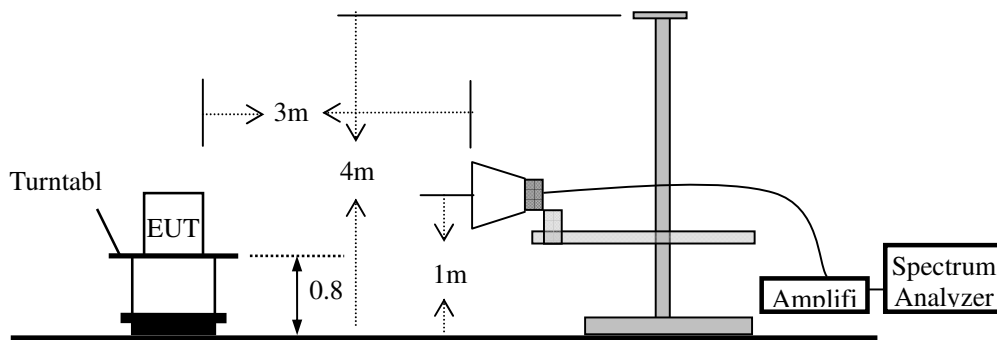

Substituted Method Test Set-UP

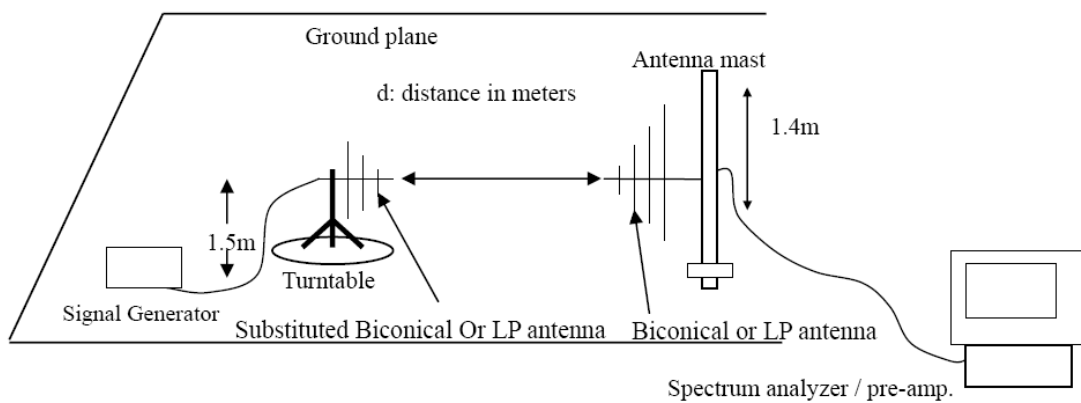



Conducted Power:

Cellular Band (Part 22H) GSM 850				
Humidity :		50 %	Temperature :	22 °C
Test Result:		PASS	Test By:	Sance
Mode	Channel	Frequency (MHz)	Output Power (dBm)	Tune up power tolerant
GSM (1 Uplink)	128	824.2	31.5	32 ± 1
	189	836.4	31.2	32 ± 1
	251	848.8	31.4	32 ± 1
GPRS 8 (1 Uplink)	128	824.2	31.3	32 ± 1
	189	836.4	31.6	32 ± 1
	251	848.8	31.8	32 ± 1
GPRS 10 (2 Uplink)	128	824.2	29.1	30 ± 1
	189	836.4	29.3	30 ± 1
	251	848.8	29.2	30 ± 1
GPRS 12 (4 Uplink)	128	824.2	25.4	26 ± 1
	189	836.4	25.6	26 ± 1
	251	848.8	25.3	26 ± 1

PCS Band (Part 24E) PCS 1900				
Humidity :		50 %	Temperature :	22 °C
Test Result:		PASS	Test By:	Sance
Mode	Channel	Frequency (MHz)	Output Power (dBm)	Tune up power tolerant
GSM (1 Uplink)	512	1850.2	28.34	29 ± 1
	661	1880.0	28.16	29 ± 1
	810	1909.8	28.09	29 ± 1
GPRS 8 (1 Uplink)	512	1850.2	28.31	29 ± 1
	661	1880.0	28.20	29 ± 1
	810	1909.8	28.14	29 ± 1
GPRS 10 (2 Uplink)	512	1850.2	25.37	26 ± 1
	661	1880.0	26.25	26 ± 1
	810	1909.8	26.19	26 ± 1
GPRS 12 (4 Uplink)	512	1850.2	22.40	23 ± 1
	661	1880.0	22.28	23 ± 1
	810	1909.8	22.11	23 ± 1

Note: Measurement uncertainty ±0.56dB



Radiated Power (ERP and EIRP)

Cellular Band (Part 22H)							
Humidity :		50 %	Temperature :			22 °C	
Mode:		GSM850	Test By:			Sance	
Test Result:		PASS					
Channel	Frequency (MHz)	Substituted level (dBm)	Polarization (H/V) Antenna	Gain Correction (dBi)	Cable Loss (dB)	Absolute Level (dBm)	Limit (dBm)
128	824.2	18.76	H	7.86	0.9	25.72	38.45
		11.67	V	7.86	0.9	18.63	38.45
189	836.4	17.14	H	7.81	0.9	24.05	38.45
		10.78	V	7.81	0.9	17.69	38.45
251	848.8	17.87	H	7.81	0.9	24.78	38.45
		11.00	V	7.81	0.9	17.91	38.45

PCS Band (Part 24E)							
Humidity :		50 %	Temperature :			22 °C	
Mode:		PCS1900	Test By:			Sance	
Test Result:		PASS					
Channel	Frequency (MHz)	Substituted level (dBm)	Polarization (H/V) Antenna	Gain Correction (dBi)	Cable Loss (dB)	Absolute Level (dBm)	Limit (dBm)
512	1850.2	15.20	H	8.04	2.3	20.94	33.0
		11.01	V	8.04	2.3	16.75	33.0
661	1880.0	14.43	H	8.06	2.3	20.19	33.0
		10.47	V	8.06	2.3	16.23	33.0
810	1909.8	15.00	H	8.09	2.3	20.79	33.0
		11.19	V	8.09	2.3	16.98	33.0

Note: Measurement uncertainty ±3.7dB.

3. TEST OCCUPIED BANDWIDTH

3.1 Applicable Standard

CFR 47 §2.1049, §22.917, §22.905 and §24.238.

3.2 Test Procedure

The RF output of the transmitter was connected to the simulator and the spectrum analyzer through sufficient attenuation.

The resolution bandwidth of the spectrum analyzer was set at 30 kHz (Cellular /PCS) and the 26 dB & 99% bandwidth was recorded.

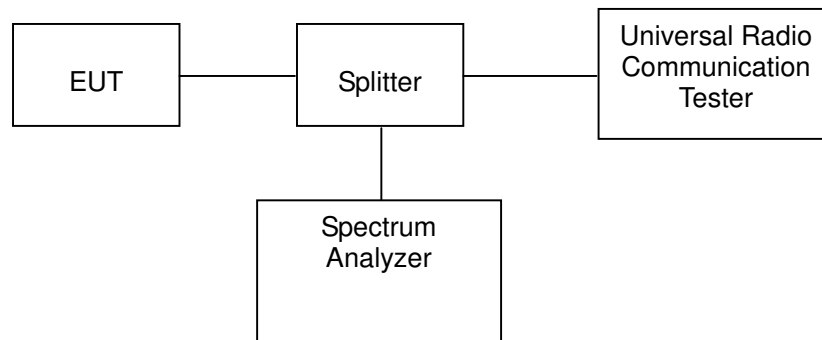



Cellular Band (Part 22H)				
Humidity :		50 %	Temperature :	22 °C
Test Result:		PASS	Test By:	Sance
Mode	Channel	Frequency (MHz)	99% Power Bandwidth (kHz)	26 dB Bandwidth (kHz)
GSM850	128	824.2	243.5897	317.3077
	189	836.4	245.1923	320.5128
	251	848.8	245.1923	318.9103

PCS Band (Part 24E)				
Humidity :		50 %	Temperature :	22 °C
Test Result:		PASS	Test By:	Sance
Mode	Channel	Frequency (MHz)	99% Power Bandwidth (kHz)	26 dB Bandwidth (kHz)
PCS1900	512	1850.2	245.1923	320.5128
	661	1880.0	243.5897	310.8974
	810	1909.8	243.5897	323.7179

Cellular Band (Part 22H)

26 dB Bandwidth (Channel 128)

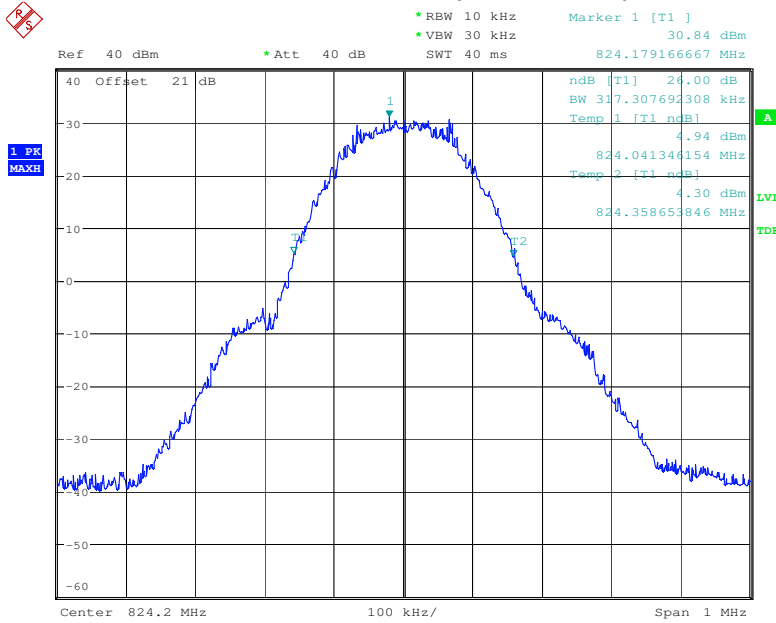

Date: 10.MAY.2016 17:35:19

99% Band width (Channel 128)

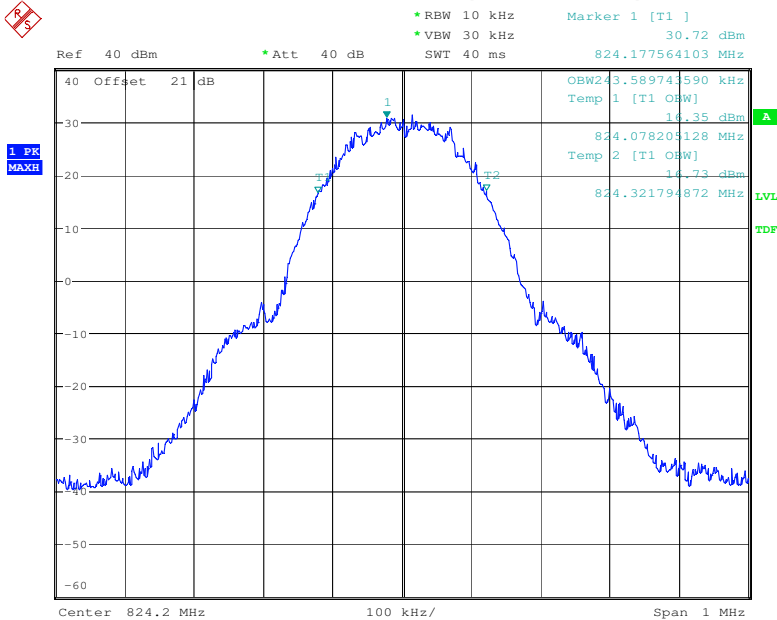

Date: 10.MAY.2016 17:34:44

Cellular Band (Part 22H)

26 dB Bandwidth (Channel 189)

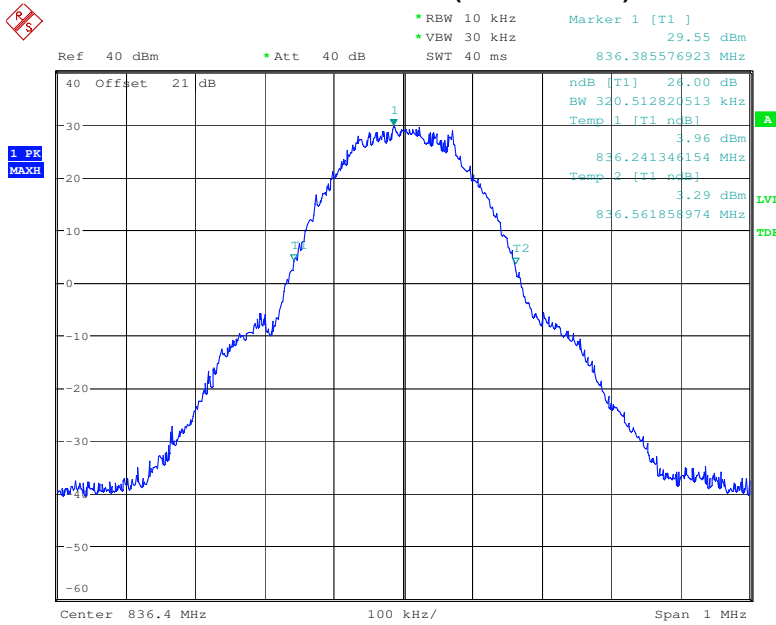

Date: 10.MAY.2016 17:51:05

99% Band width (Channel 189)

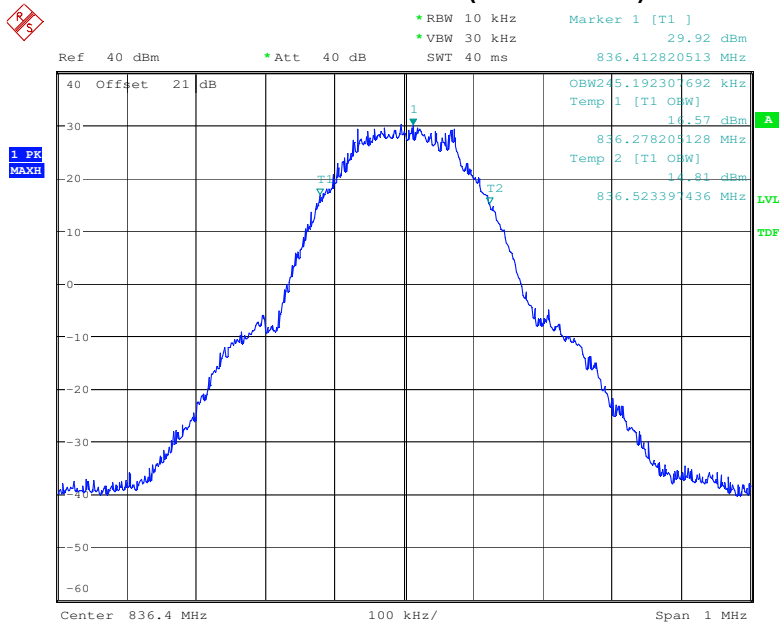

Date: 10.MAY.2016 17:51:44

Cellular Band (Part 22H)

26 dB Bandwidth (Channel 251)

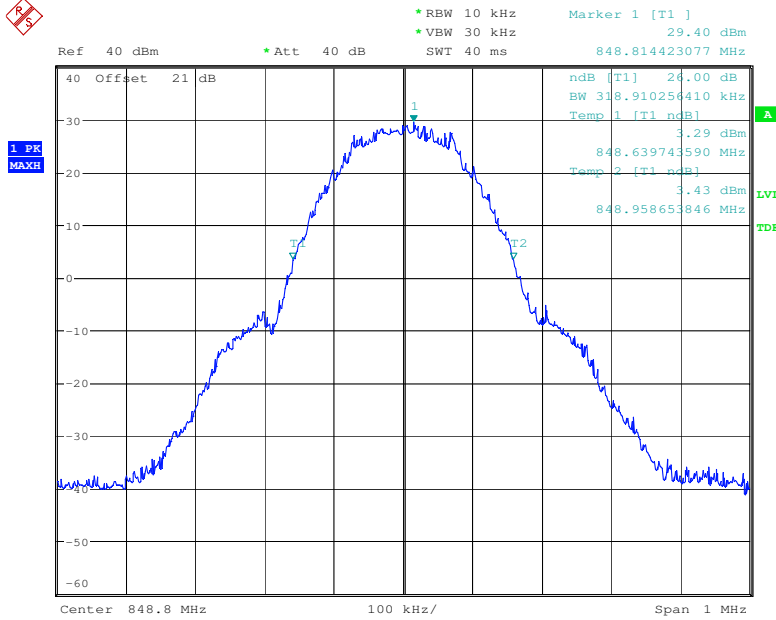

Date: 10.MAY.2016 17:55:33

99% Band width (Channel 251)

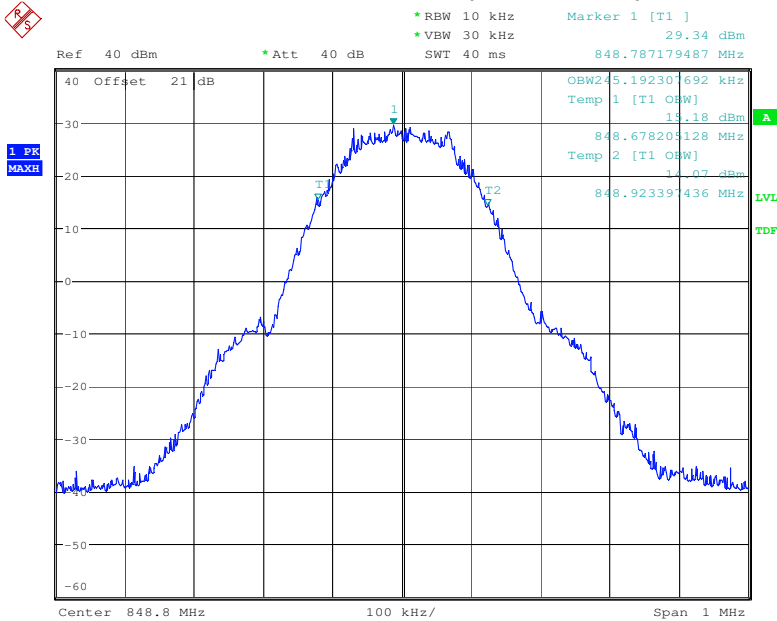

Date: 10.MAY.2016 17:56:15

PCS Band (Part 24H)

26 dB Bandwidth (Channel 512)

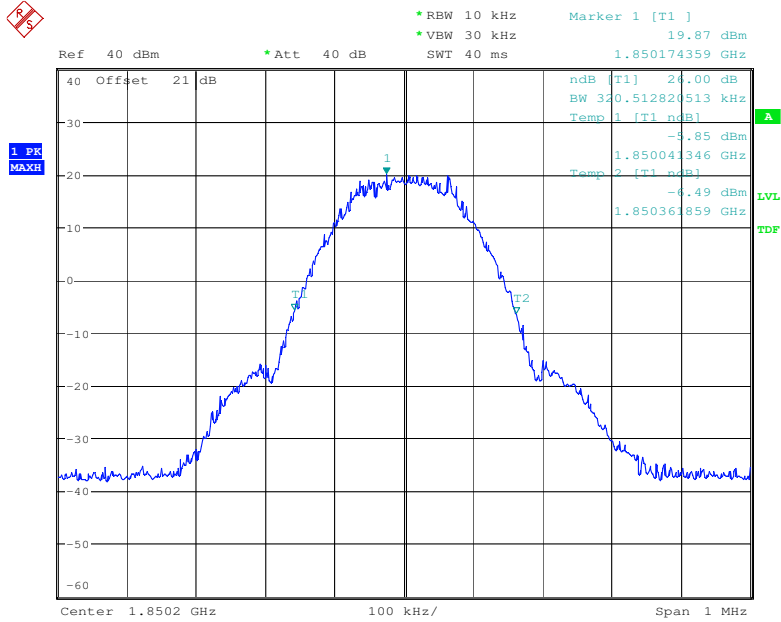

Date: 10.MAY.2016 18:12:18

99% Band width (Channel 512)

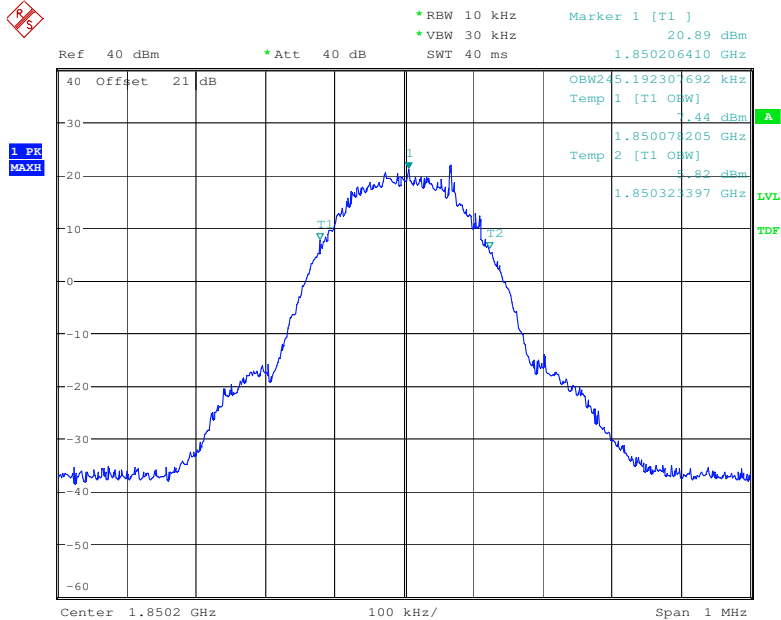

Date: 10.MAY.2016 18:13:06

PCS Band (Part 24H)

26 dB Bandwidth (Channel 661)

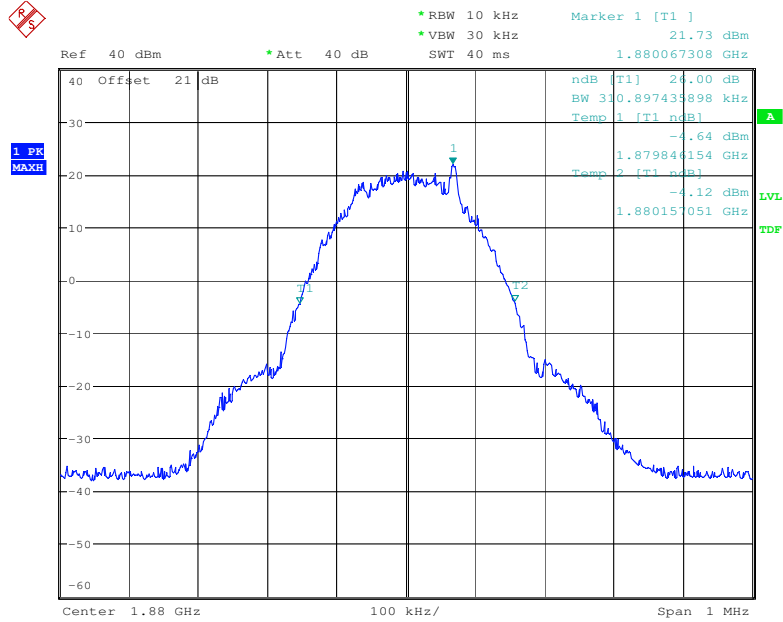

Date: 10.MAY.2016 18:20:22

99% Band width (Channel 661)

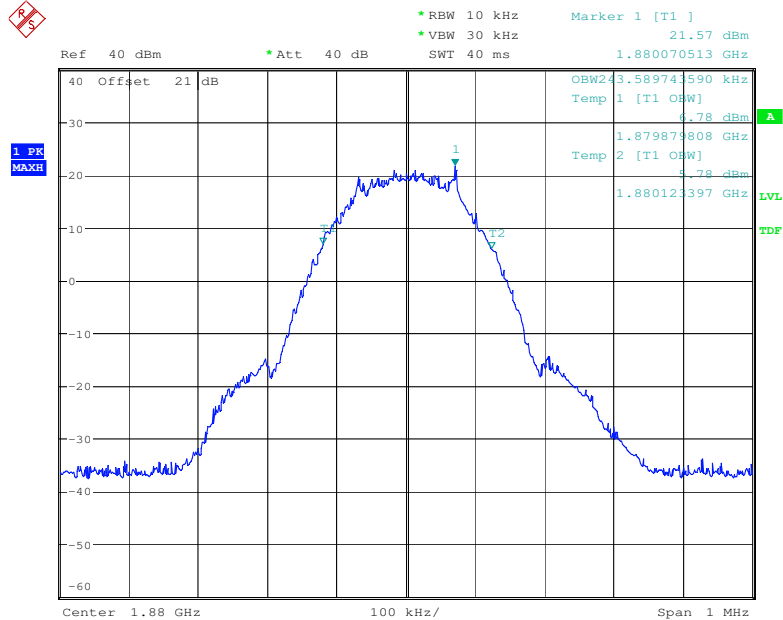

Date: 10.MAY.2016 18:22:12

PCS Band (Part 24H)

26 dB Bandwidth (Channel 810)

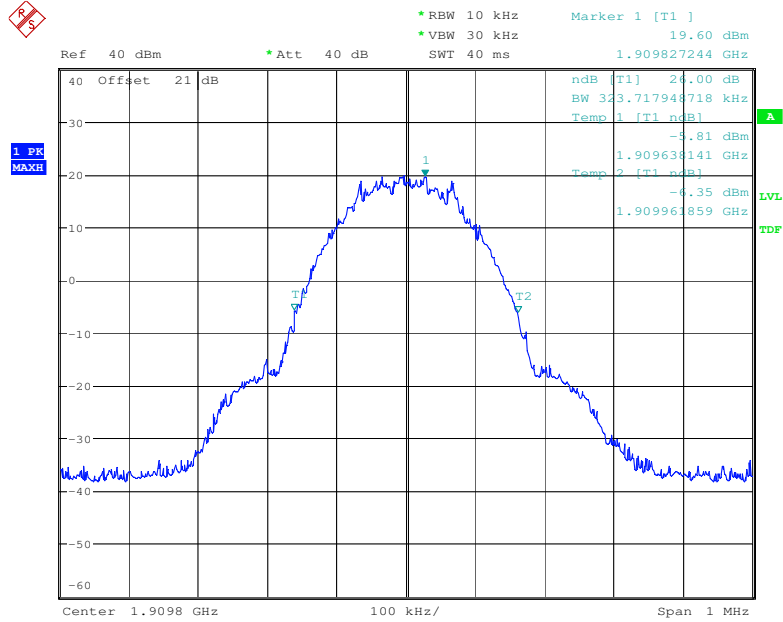

Date: 10.MAY.2016 18:31:42

99% Band width (Channel 810)

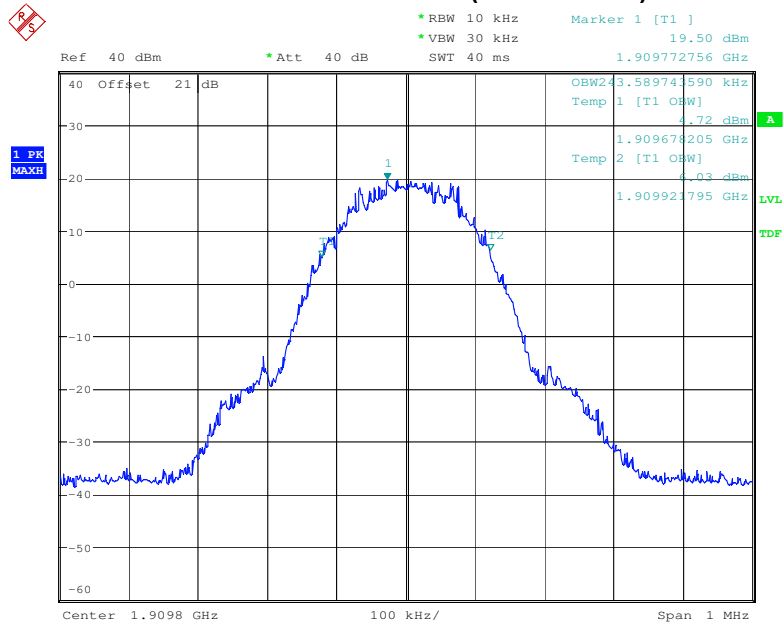

Date: 10.MAY.2016 18:32:13

4. FREQUENCY STABILITY

4.1 Applicable Standard

CFR47 § 2.1055 (a), § 2.1055 (d), §22.355, §24.235

According to §22.355, the carrier frequency of each transmitter in the Public Mobile Services must be maintained within the tolerances given in Table below:

Frequency Tolerance for Transmitters in the Public Mobile Services

Frequency Range (MHz)	Base, fixed (ppm)	Mobile ≤ 3 watts (ppm)	Mobile ≤ 3 watts (ppm)
25 to 50	20.0	20.0	50.0
50 to 450	5.0	5.0	50.0
450 to 512	2.5	5.0	5.0
821 to 896	1.5	2.5	2.5
928 to 929.	5.0	N/A	N/A
929 to 960.	1.5	N/A	N/A
2110 to 2220	10.0	N/A	N/A

According to §24.235, the frequency stability shall be sufficient to ensure that the fundamental emissions stays within the authorized frequency block.

4.2 Test Procedure

Frequency Stability vs. Temperature: The equipment under test was connected to an external DC power supply and the RF output was connected to communication test set via feed-through attenuators. The EUT was placed inside the temperature chamber. The DC leads and RF output cable exited the chamber through an opening made for the purpose.

After the temperature stabilized for approximately 30 minutes, the frequency output was recorded from the communication test set.

Frequency Stability vs. Voltage: An external variable DC power supply was connected to the battery terminals of the equipment under test. The voltage was set to 115% of the nominal value and was then decreased until the transmitter light no longer illuminated; i.e., the battery end point. The output frequency was recorded for each battery voltage.

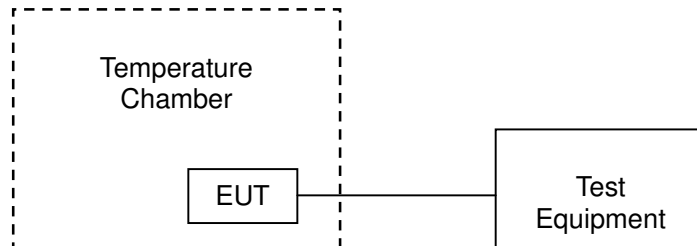

Cellular Band				
Humidity :	50 %	Temperature :	22 °C	
Mode:	GSM850	Test By:	Sance	
Test Result:	PASS			
Middle channel, $f_o = 836.4\text{MHz}$;				
Temperature (°C)	Power Supplied (Vdc)	Frequency Error (Hz)	Frequency Error (ppm)	Limit (ppm)
-10	3.8	22	0.026303	2.5
0		18	0.021521	2.5
10		17	0.020325	2.5
20		14	0.016738	2.5
30		15	0.017934	2.5
40		11	0.013152	2.5
50		20	0.023912	2.5
55		26	0.031086	2.5
25		3.8	7	0.008369
	4.2	9	0.010760	2.5
	3.5	10	0.011956	2.5

Note: The manufacturer declared that the EUT could work within temperature range -10°C to 55°C and voltage range DC 3.5V to DC 4.2V. The nominal voltage is DC 3.8V.



PCS Band				
Humidity :	50 %	Temperature :	22 °C	
Mode:	PCS1900	Test By:	Sance	
Test Result:	PASS			
Middle channel, f _o =1880.0MHz;				
Temperature (°C)	Power Supplied (Vdc)	Frequency Error (Hz)	Frequency Error (ppm)	Limit (ppm)
-10	3.8	-23	-0.012230	2.5
0		-34	-0.018090	2.5
10		10	0.005319	2.5
20		19	0.010106	2.5
30		28	0.014894	2.5
40		15	0.007979	2.5
50		-11	-0.005850	2.5
55		-17	-0.009040	2.5
25		3.8	14	0.007447
	4.2	21	0.011170	2.5
	3.5	19	0.010106	2.5

Note: The manufacturer declared that the EUT could work within temperature range -10°C to 55°C and voltage range DC 3.5V to DC 4.2V. The nominal voltage is DC 3.8V.

5. BAND EDGES

5.1 Applicable Standard

According to § 22.917(a), the power of any emissions outside of the authorized operating frequency ranges must be attenuated below the transmitting power (P) by a factor of at least $43 + 10 \log(P)$ dB.

According to §24.238(a), the power of any emissions outside of the authorized operating frequency ranges must be attenuated below the transmitting power (P) by a factor of at least $43 + 10 \log(P)$ dB.

5.2 Test Procedure

The RF output of the transmitter was connected to the input of the spectrum analyzer through sufficient attenuation.

The center of the spectrum analyzer was set to block edge frequency, RBW set to 3 kHz.

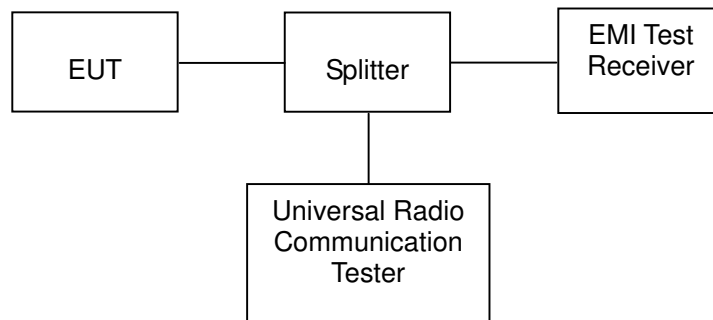



Cellular Band			
Humidity :	50 %	Temperature :	22 °C
Test Result:	PASS	Test By:	Sance
Mode	GSM850		
Frequency (MHz)	Emission (dBm)	Limit (dBm)	
824	-15.32	-13	
849	-14.35	-13	

PCS Band			
Humidity :	50 %	Temperature :	22 °C
Test Result:	PASS	Test By:	Sance
Mode	PCS1900		
Frequency (MHz)	Emission (dBm)	Limit (dBm)	
1850	-20.96	-13	
1910	-20.02	-13	

Note: 1. Offset=External Attenuator+cable loss+10log(1%Emission BW/RBW)=21.0dB

2. Measurement uncertainty ±0.56dB

Cellular Band, Low Channel (GSM)

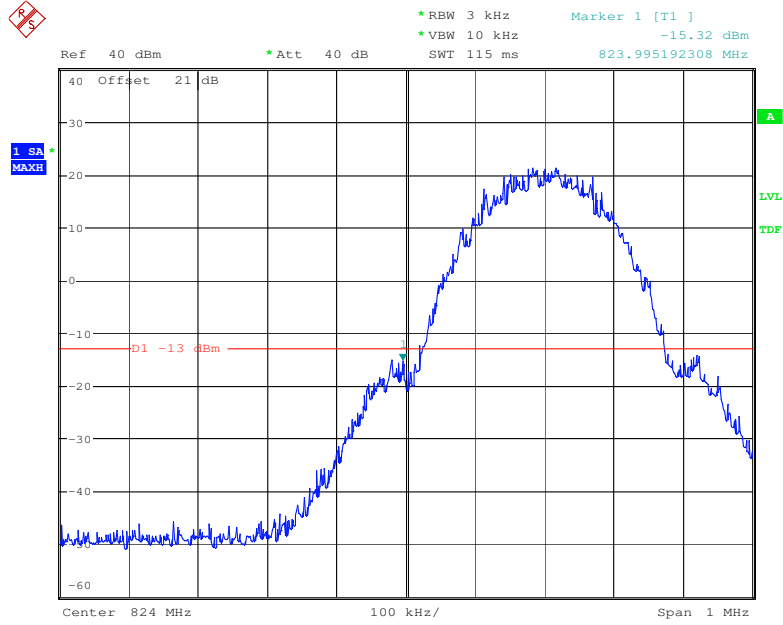

Date: 10.MAY.2016 17:45:15

Cellular Band, High Channel (GSM)

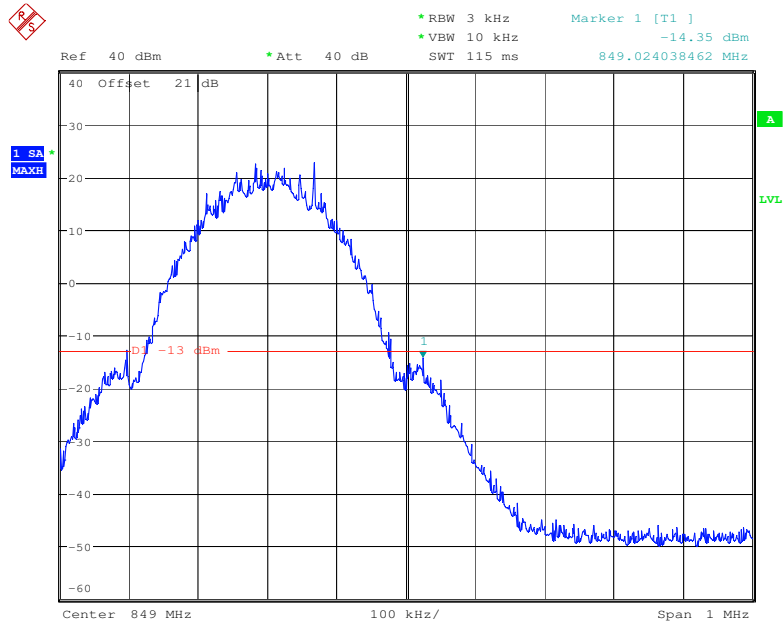

Date: 10.MAY.2016 17:59:10

PCS Band, Low Channel (GSM)

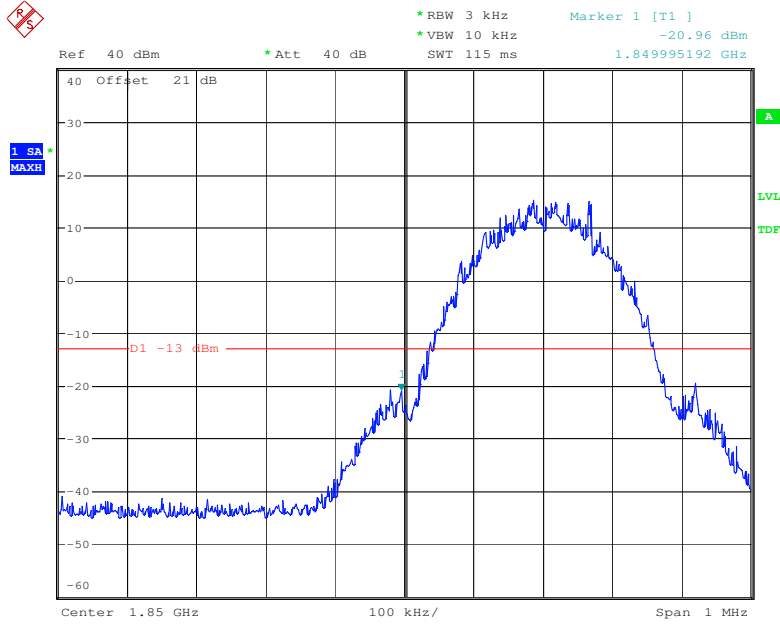

Date: 10.MAY.2016 18:15:41

PCS Band, High Channel (GSM)

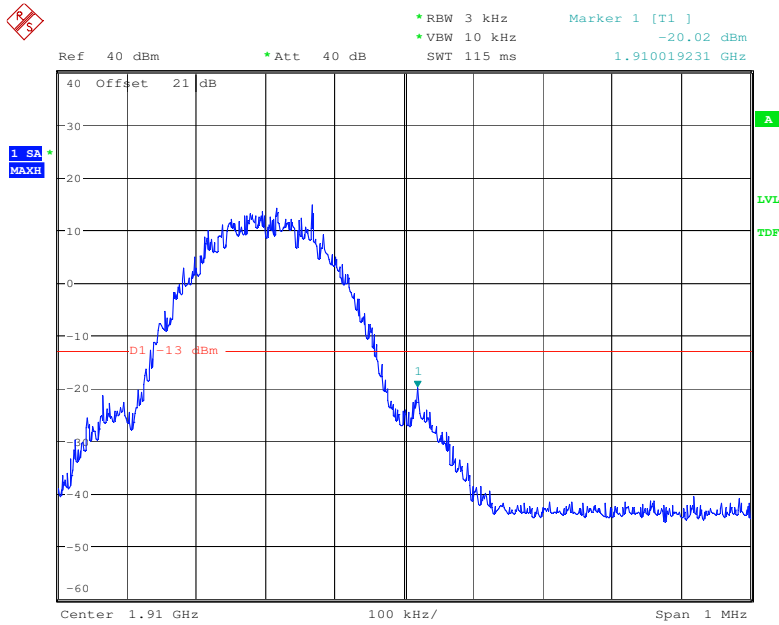

Date: 10.MAY.2016 18:33:21

6. MODULATION CHARACTERISTIC

According to FCC § 2.1047(d), Part 22H & 24E there is no specific requirement for digital modulation, therefore modulation characteristic is not presented.

7. SPURIOUS EMISSIONS AT ANTENNA TERMINALS

7.1 Applicable Standards

CFR 47 §2.1051, §22.917(a) and §24.238(a).

The spectrum was to be investigated to the tenth harmonics of the highest fundamental frequency as specified in § 2.1051.

7.2 Test Procedure

The RF output of the transceiver was connected to a spectrum analyzer and simulator through appropriate attenuation. The resolution bandwidth of the spectrum analyzer was set at 1000 kHz. Sufficient scans were taken to show any out of band emissions up to 10th harmonic.

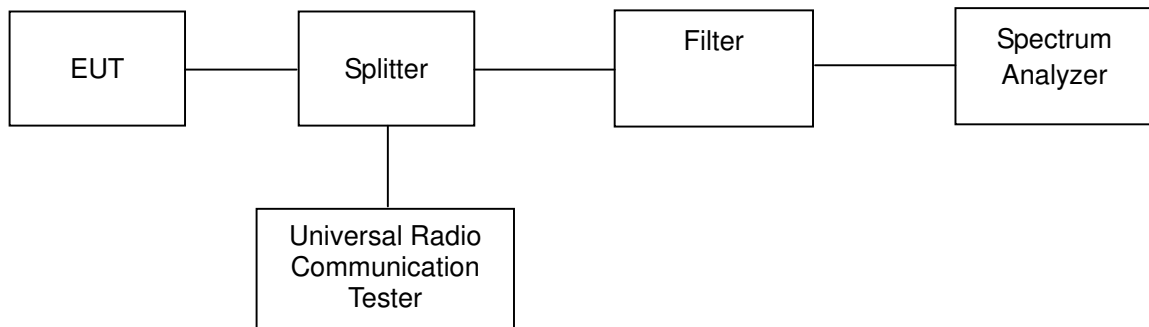

Cellular Band (Part 22H) 30 – 1000 MHz - Channel 128(GSM)

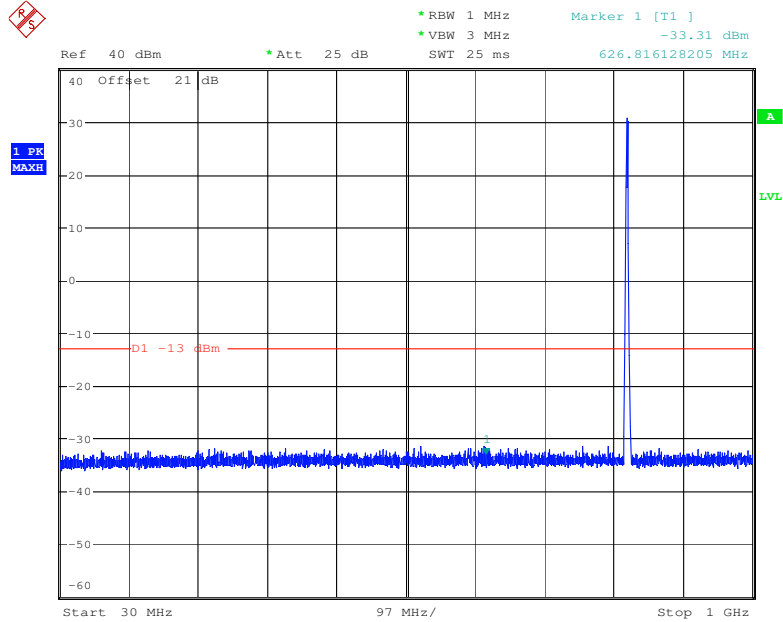

Date: 10.MAY.2016 17:38:16

1GHz – 20GHz - Channel 128(GSM)

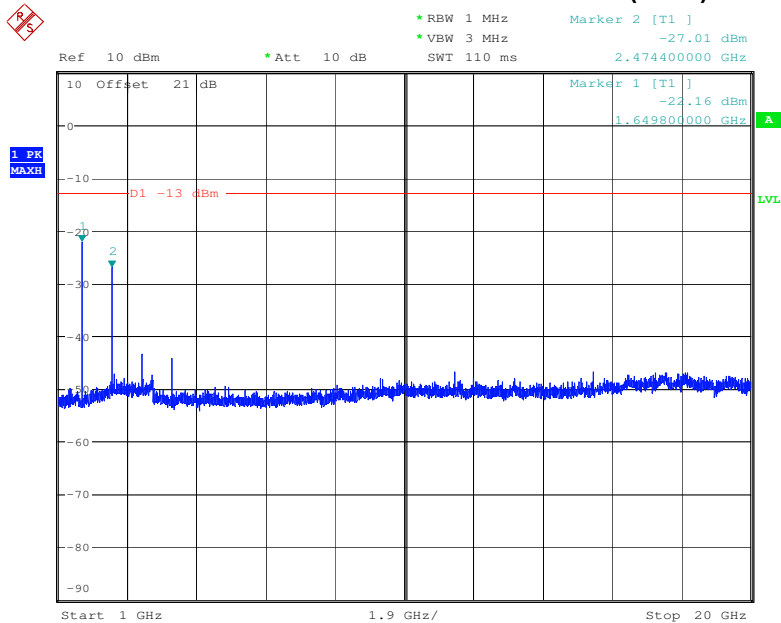

Date: 10.MAY.2016 17:39:51

30MHz – 1GHz - Channel 189(GSM)

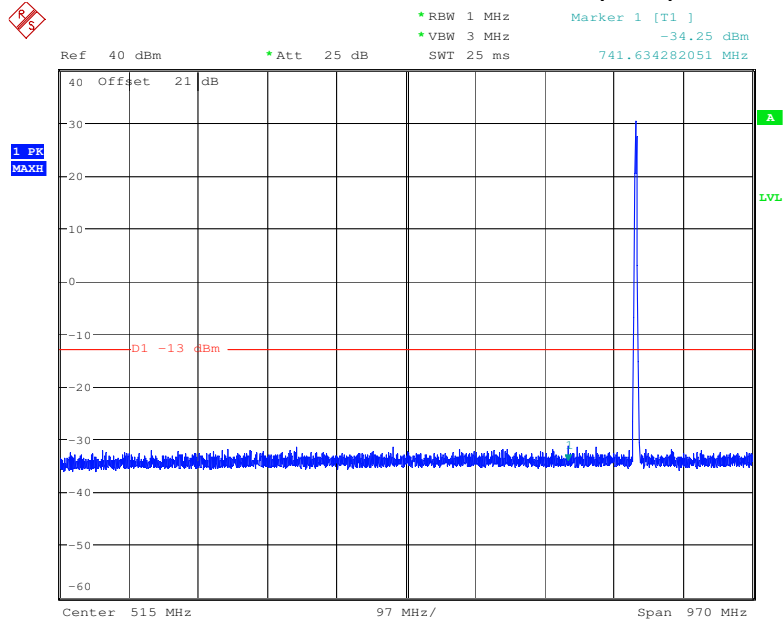

Date: 10.MAY.2016 17:52:32

1GHz – 20GHz - Channel 189(GSM)

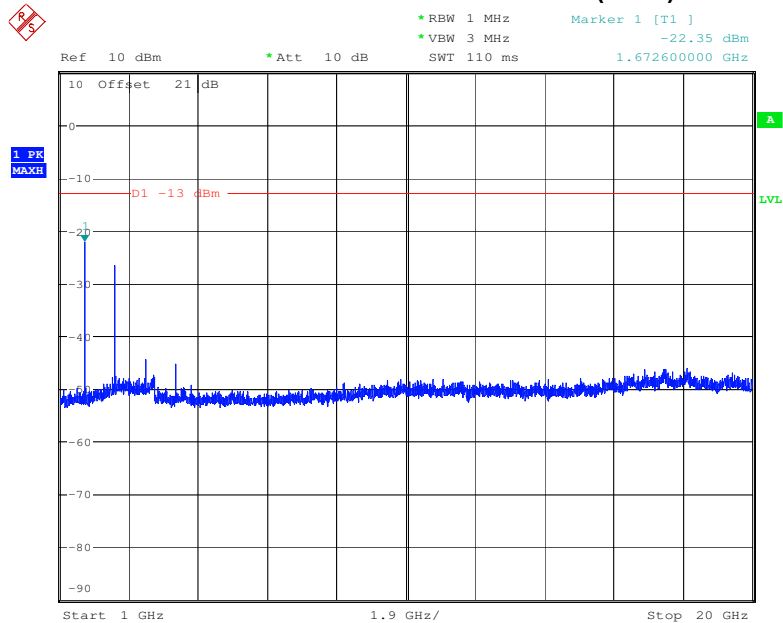

Date: 10.MAY.2016 17:53:15

30MHz – 1GHz - Channel 251(GSM)

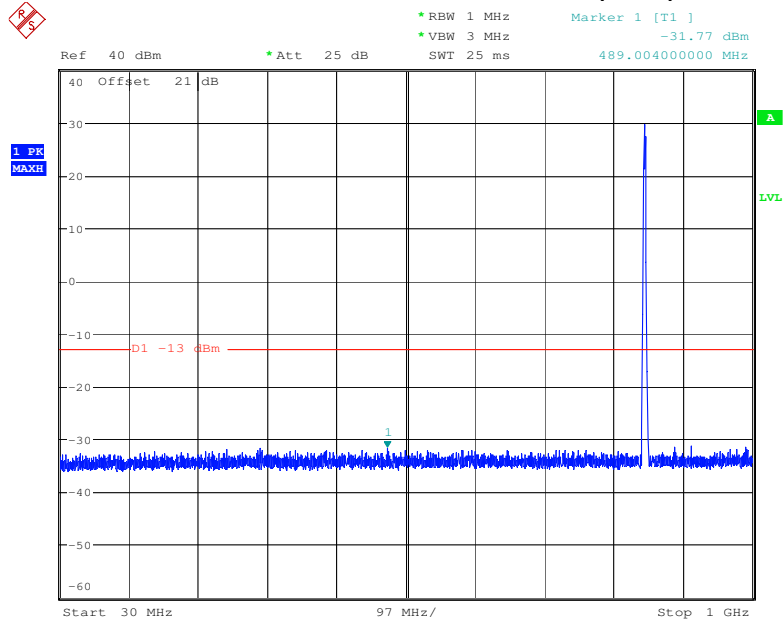

Date: 10.MAY.2016 18:00:54

1GHz – 20GHz - Channel 251(GSM)

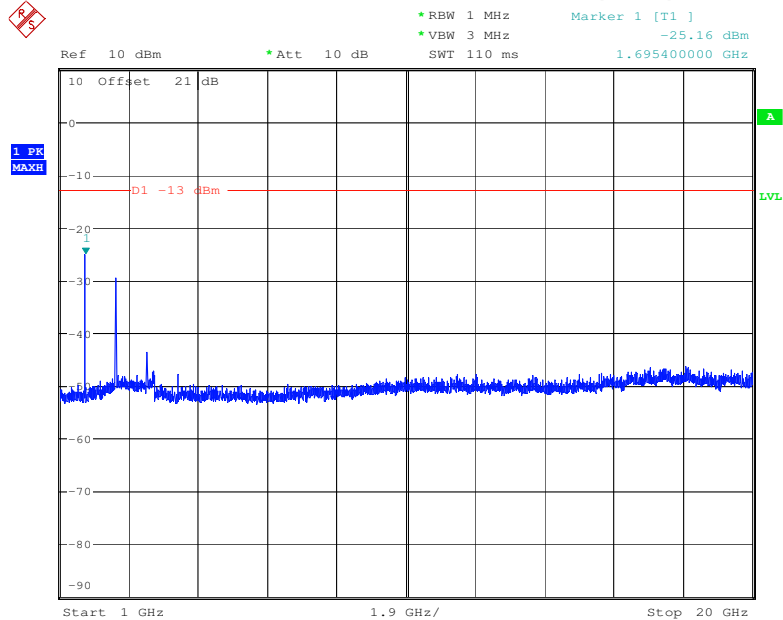

Date: 10.MAY.2016 18:01:42

PCS Band (Part24E) 30 – 1000 MHz - Channel 512(GSM)

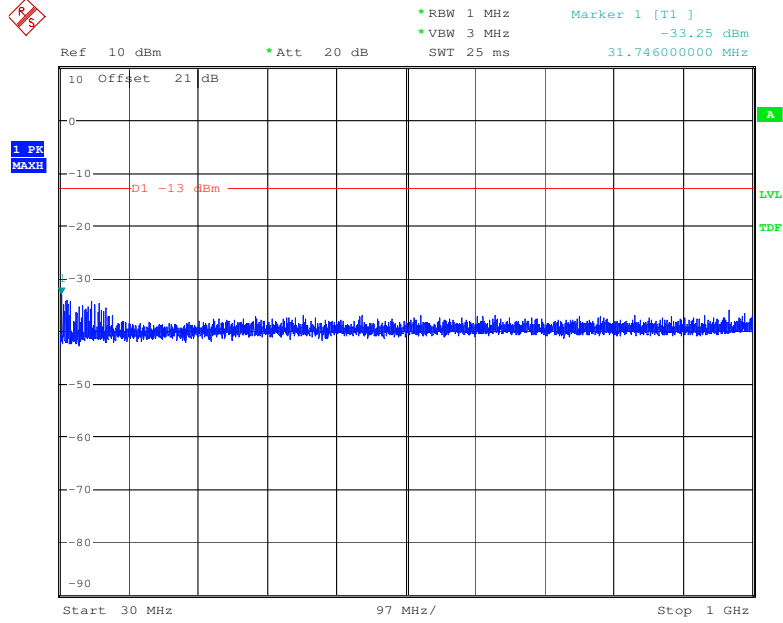

Date: 10.MAY.2016 18:17:18

1GHz – 20GHz - Channel 512(GSM)

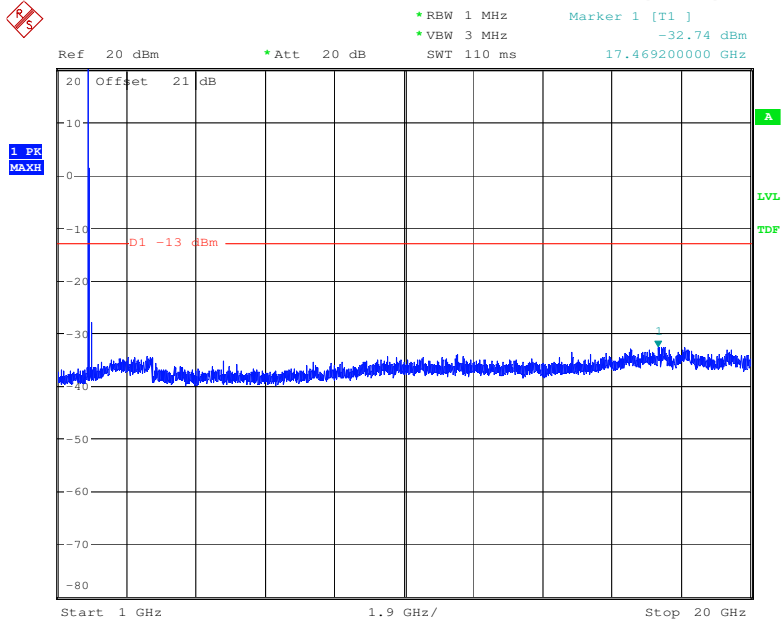

Date: 10.MAY.2016 18:18:09

30 – 1000MHz - Channel 661(GSM)

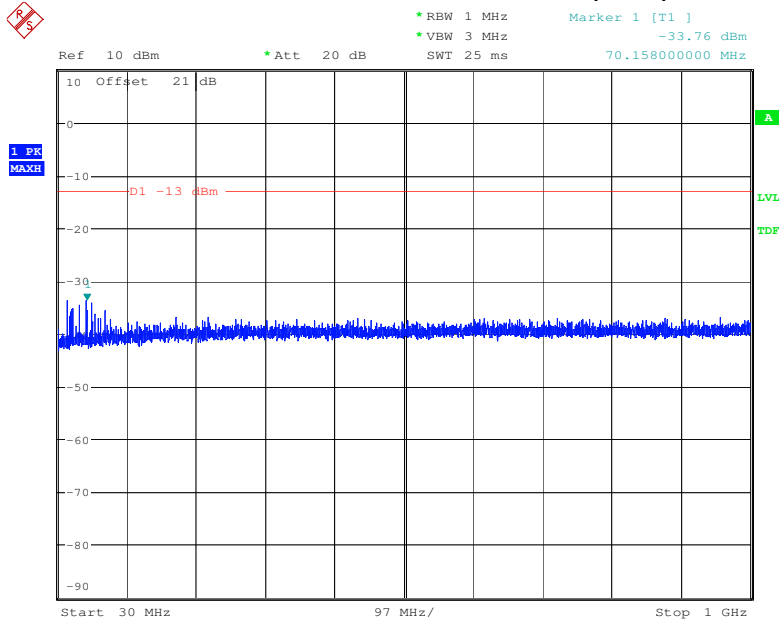

Date: 10.MAY.2016 18:36:29

1GHz – 20GHz - Channel 661(GSM)

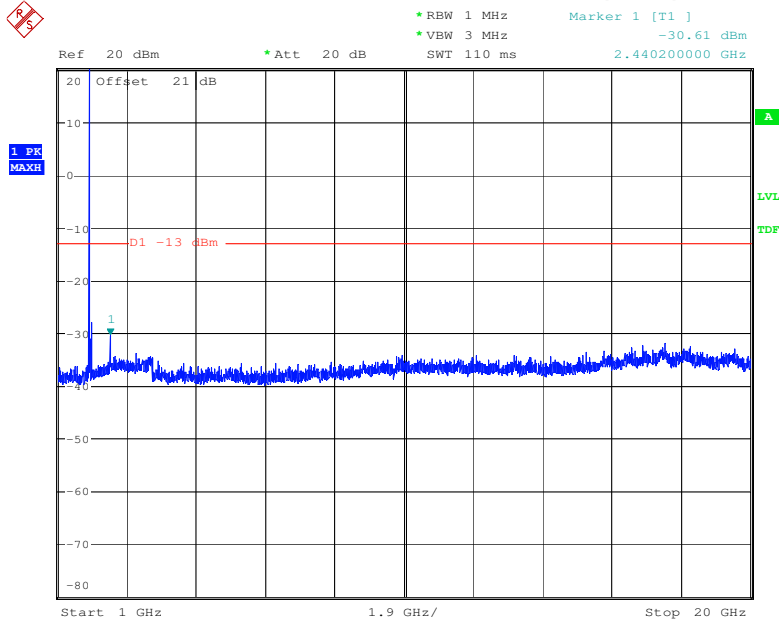

Date: 10.MAY.2016 18:37:12

30 – 1000MHz - Channel 810(GSM)

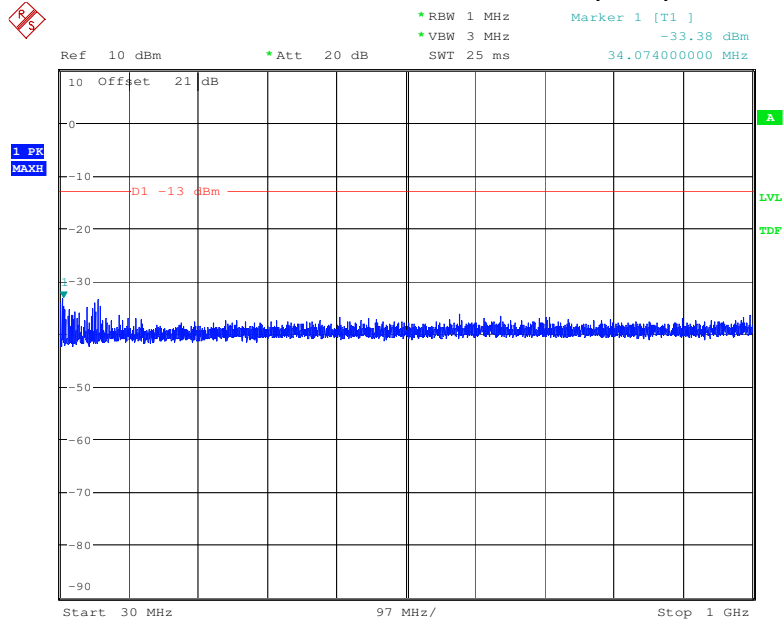

Date: 10.MAY.2016 18:35:19

1GHz – 20GHz - Channel 810(GSM)

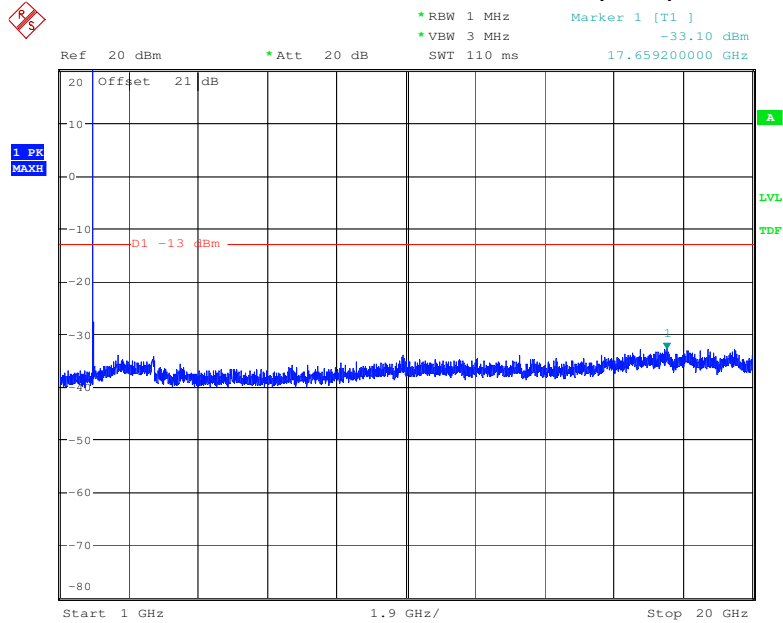

Date: 10.MAY.2016 18:35:50

8. FIELD STRENGTH OF SPURIOUS RADIATED EMISSIONS

8.1 Applicable Standards

According to FCC §2.1053

FCC §22.917(a), §24.238(a), the magnitude of each spurious and harmonic emission that can be detected when the equipment is operated under the conditions specified in the instruction manual and/ or alignment procedure, shall not be less than $43 + 10 \log$ (mean output power in watts) dBc below the mean power output outside a license's frequency block (-13dBm)

8.2 Test of Block Diagram of configuration

Radiated Emission Test Set-Up, Frequency Below 1000MHz

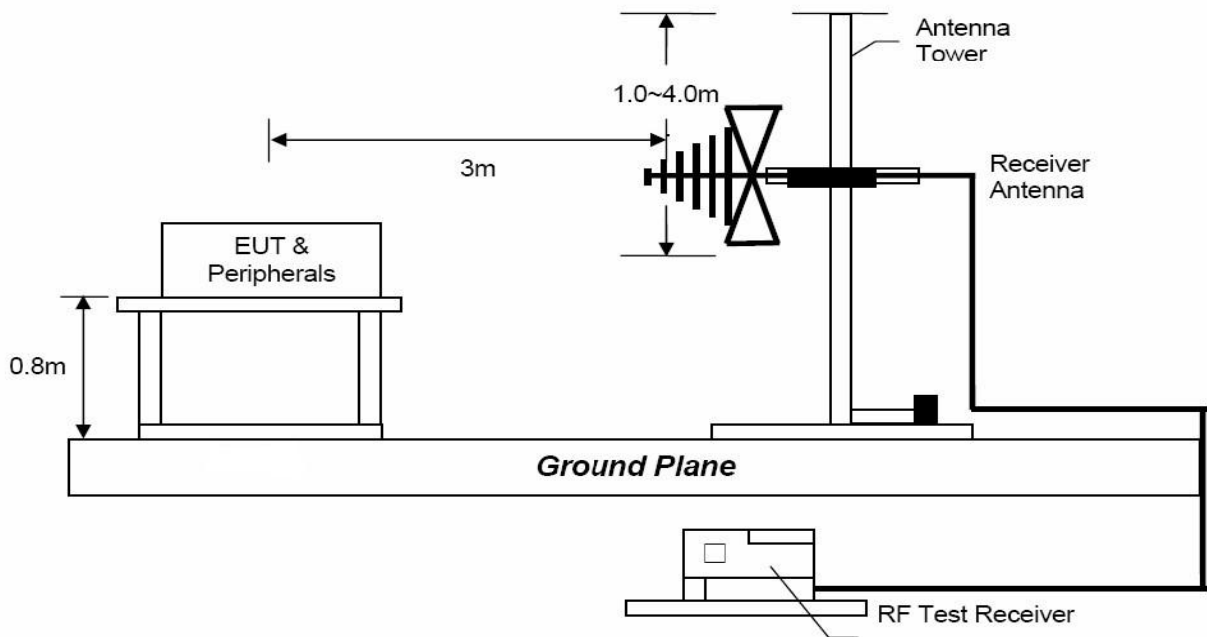

Radiated Emission Test Set-Up, Frequency above 1GHz

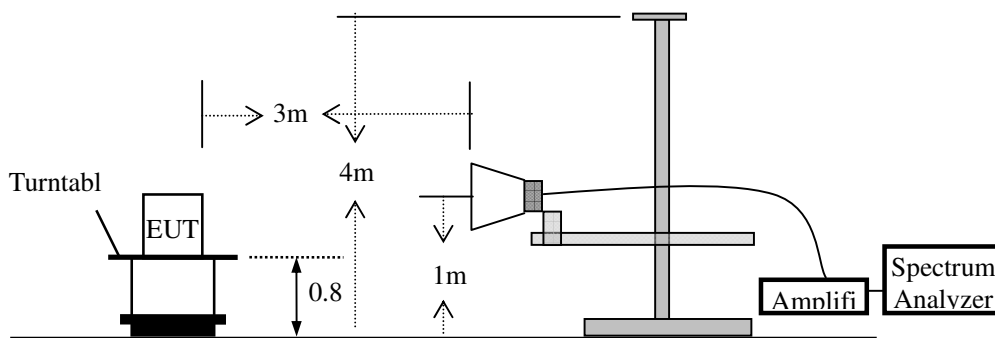

Substituted Method Test Set-UP

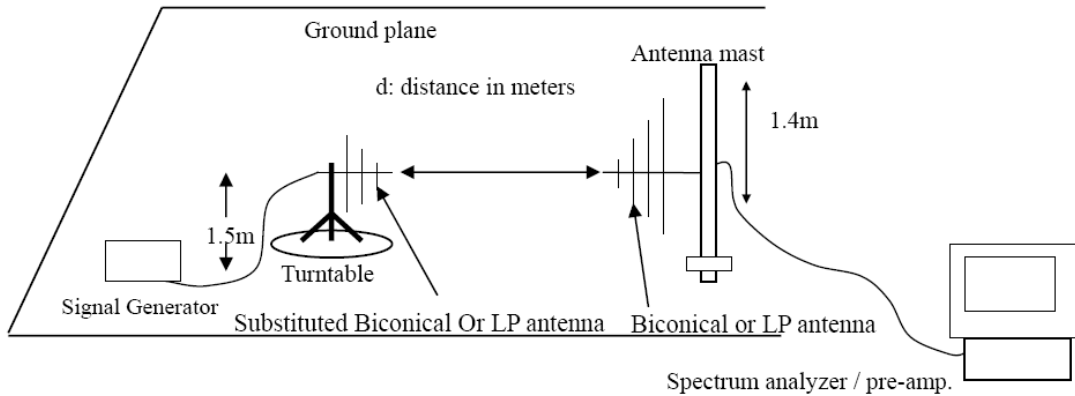

8.3 Test Procedure

The EUT was placed on a non-conductive, The measurement antenna was placed at a distance of 3 meters from the EUT. During the tests, the antenna height and the EUT azimuth were varied in order to identify the maximum level of emissions from the EUT. This maximization process was repeated with the EUT positioned in each of its three orthogonal orientations. The frequency range up to tenth harmonic was investigated for each of three fundamental frequency (low, middle and high channels). Once spurious emission were identified, the power of the emission was determined using the substitution method. The spurious emissions attenuation was calculated as the difference between radiated power at the fundamental frequency and the spurious emissions frequency. $EIRP = S.G. \text{ output (dBm)} + \text{Antenna Gain(dBi)} - \text{Cable Loss (dB)}$



Cellular Band (Part 22H)							
Humidity :		50 %	Temperature :			22 °C	
Mode:		GSM850	Test By:			Sance	
Test Result:		PASS					
Channel	Frequency (MHz)	Substituted level (dBm)	Polarization (H/V) Antenna	Gain Correction (dBi)	Cable Loss (dB)	Absolute Level (dBm)	Limit (dBm)
128	1648.4	-37.64	H	8.26	2.1	-31.48	-13.00
	1648.4	-40.32	V	8.26	2.1	-34.16	-13.00
	2472.6	-42.02	H	9.2	2.6	-35.42	-13.00
	2472.6	-44.29	V	9.2	2.6	-37.69	-13.00
189	1672.4	-39.03	H	8.26	2.1	-32.87	-13.00
	1672.4	-42.12	V	8.26	2.1	-35.96	-13.00
	2509.2	-40.65	H	9.2	2.6	-34.05	-13.00
	2509.2	-45.33	V	9.2	2.6	-38.73	-13.00
251	1697.6	-39.78	H	8.24	2.1	-33.64	-13.00
	1697.6	-43.36	V	8.24	2.1	-37.22	-13.00
	2546.4	-45.49	H	9.3	2.6	-38.79	-13.00
	2546.4	-46.75	V	9.3	2.6	-40.05	-13.00

Note: 1. Spurious emissions below 1000MHz were found more than 20dB below limit line.
 2. Measurement uncertainty : ±3.7dB.



PCS Band (Part 24E)							
Humidity :		50 %	Temperature :			22 °C	
Mode:		PCS1900	Test By:			Sance	
Test Result:		PASS					
Channel	Frequency (MHz)	Substituted level (dBm)	Polarization (H/V) Antenna	Gain Correction (dBi)	Cable Loss (dB)	Absolute Level (dBm)	Limit (dBm)
512	3700.4	-46.55	H	10.5	3.8	-39.85	-13.00
	3700.4	-48.96	V	10.5	3.8	-42.26	-13.00
661	3760	-45.06	H	10.5	3.9	-38.46	-13.00
	3760	-46.70	V	10.5	3.9	-40.10	-13.00
810	3819.6	-44.93	H	10.6	4.0	-38.33	-13.00
	3819.6	-47.89	V	10.6	4.0	-41.29	-13.00

Note: 1. Spurious emissions below 1000MHz were found more than 20dB below limit line.
 2. Measurement uncertainty : ±3.7dB.

9. RF Exposure

9.1 Applicable Standards

§1.1307 and §2.1093.

9.2 Test Result

Compliance

The EUT is a portable device, thus requires SAR evaluation; please refer to SAR Report Number: WTS16S0449330E.



10. Test Equipment List

Description	Manufacturer	Model Number	Serial Number	Calibration Date	Calibration Due Date
Test Receiver	Rohde & Schwarz	ESCI7	100837	Nov. 23, 2015	Nov. 22, 2016
Antenna	Schwarzbeck	VULB9162	9162-010	Nov. 26, 2015	Nov. 25, 2016
Cable	Huber+Suhner	CBL2-NN-1M	22390001	Nov. 07, 2015	Nov. 06, 2016
Antenna	Teseq	CBL 6111D	27086	Nov. 26, 2015	Nov. 25, 2016
Power Amplifier	HP	HP 8447D	1145A00203	Nov. 07, 2015	Nov. 06, 2016
Horn Antenna	Schwarzbeck	BBHA9170	9170-372	Oct. 23, 2015	Oct. 22, 2016
Horn Antenna	Com-Power	AH-118	071078	Nov. 05, 2015	Nov. 04, 2016
Analyzer Modulation	HP	8901A	2026A00847	Dec. 24, 2015	Dec. 23, 2016
Spectrum Analyzer	Rohde & Schwarz	FSU26	200409/026	Sep. 01, 2015	Aug. 31, 2016
Pre-Amplifier	Agilent	8449B	3008A02964	Nov. 03, 2015	Nov. 02, 2016
SMA Cable	REBES	A46-NMNM	N/A	Nov. 07, 2015	Nov. 06, 2016
Temperature & Humidity Chamber	BELL	BE-TH-408	N/A	Dec. 24, 2015	Dec. 23, 2016
DC Source	HUAYI	HY5003-2	N/A	Dec. 24, 2015	Dec. 23, 2016
Signal Generator	Agilent	N5182A	MY48180739	Mar. 07, 2016	Mar. 06, 2017
Universal Radio Communication Tester	Rohde & Schwarz	CMU200	117060	Mar. 07, 2016	Mar. 06, 2017

--End--