

## TEST REPORT

**Report No.: 16051096HKG-001R2**

Samsung Pay, Inc.

Application For Certification  
(Original Grant)

**FCC ID: 2AIGR-SPTPD02**

Transceiver

This report supersedes previous report with report number 16051096HKG-001R1 dated April 09, 2018.  
Please refer HEE-S18-0040 Letter issued on April 11, 2018 for the detail Amendment Summary.

**Prepared and Checked by:**

**Approved by:**

Signed On File  
Wong Cheuk Ho, Herbert  
Lead Engineer

---

Koo Wai Ip  
Technical Supervisor  
Date: April 11, 2018

---

Intertek's standard Terms and Conditions can be obtained at our website <http://www.intertek.com/terms/>.

The test report only allows to be revised within the retention period unless further standard or the requirement was noticed.

This report is for the exclusive use of Intertek's Client and is provided pursuant to the agreement between Intertek and its Client. Intertek's responsibility and liability are limited to the terms and conditions of the agreement. Intertek assumes no liability to any party, other than to the Client in accordance with the agreement, for any loss, expense or damage occasioned by the use of this report. Only the Client is authorized to permit copying or distribution of this report and then only in its entirety. Any use of the Intertek name or one of its marks for the sale or advertisement of the tested material, product or service must first be approved in writing by Intertek. The observations and test results in this report are relevant only to the sample tested. This report by itself does not imply that the material, product, or service is or has ever been under an Intertek certification program.

© 2017 Intertek

**TEST REPORT****GENERAL INFORMATION**

<b>Grantee:</b>	Samsung Pay, Inc.
<b>Grantee Address:</b>	3 van de Graaff Drive, 4th floor, Burlington, MA 01803, USA.
<b>Contact Person:</b>	Julian Na
<b>Tel:</b>	(617) 279 0520
<b>Fax:</b>	(852) 2886 5705
<b>e-mail:</b>	N/A
<b>Manufacturer:</b>	(Dongguan) Heng Yong Electronic Products Co., Ltd.
<b>Manufacturer Address:</b>	No. 1, Lane 9, Wen Ming Road, Nan Zha Industrial Estate 4, Humen Town, Dongguan City, Guangdong, China
<b>Brand Name:</b>	LoopPay
<b>Model:</b>	SP-TPD02
<b>Type of EUT:</b>	Transceiver
<b>Description of EUT:</b>	Tokenized Payment Device
<b>Serial Number:</b>	N/A
<b>FCC ID:</b>	2AIGR-SPTPD02
<b>Date of Sample Submitted:</b>	May 13, 2016
<b>Date of Test:</b>	Jan 23, 2018 to March 18, 2018
<b>Report No.:</b>	16051096HKG-001R2
<b>Report Date:</b>	April 11, 2018
<b>Environmental Conditions:</b>	Temperature: +10 to 40°C Humidity: 10 to 90%

## TEST REPORT

### SUMMARY OF TEST RESULT

Test Specification	Reference	Results
Transmitter Power Line Conducted Emissions	15.207	Pass
Radiated Emission Radiated Emission on the Bandedge	15.249, 15.209	Pass
Radiated Emission in Restricted Bands	15.205	Pass

The equipment under test is found to be complying with the following standards:  
FCC Part 15, October 1, 2016 Edition

- Note:
1. The EUT uses a permanently attached antenna which, in accordance to section 15.203, is considered sufficient to comply with the pervisions of this section.
  2. Pursuant to FCC part 15 Section 15.215(c), the 20 dB bandwidth of the emission was contained within the frequency band designated (mentioned as above) which the EUT operated. The effects, if any, from frequency sweeping, frequency hopping, other modulation techniques and frequency stability over excepted variations in temperature and supply voltage were considered.

**TEST REPORT**

**TABLE OF CONTENTS**

**1.0 GENERAL DESCRIPTION ..... 5**

1.1 Product Description .....5

1.2 Related Submittal(s) Grants.....5

1.3 Test Methodology .....6

1.4 Test Facility .....6

**2.0 SYSTEM TEST CONFIGURATION..... 7**

2.1 Justification .....7

2.2 EUT Exercising Software .....7

2.3 Special Accessories.....7

2.4 Measurement Uncertainty .....7

2.5 Support Equipment List and Description .....7

**3.0 EMISSION RESULTS..... 8**

3.1 Field Strength Calculation.....8

3.2 Radiated Emission Configuration Photograph.....9

3.3 Radiated Emission Data.....9

3.4 Conducted Emission Configuration Photograph .....9

3.5 Conducted Emission Data.....9

**4.0 EQUIPMENT PHOTOGRAPHS ..... 15**

**5.0 PRODUCT LABELLING..... 15**

**6.0 TECHNICAL SPECIFICATIONS ..... 15**

**7.0 INSTRUCTION MANUAL..... 15**

**8.0 MISCELLANEOUS INFORMATION ..... 16**

8.1 Radiated Emission on the Bandedge.....16

8.2 Discussion of Pulse Desensitization .....19

8.3 Calculation of Average Factor.....19

8.4 Emissions Test Procedures .....22

**9.0 CONFIDENTIALITY REQUEST ..... 26**

**10.0 EQUIPMENT LIST ..... 26**

## TEST REPORT

### 1.0 GENERAL DESCRIPTION

#### 1.1 Product Description

The Equipment Under Test (EUT) is a Tokenized Payment Device (TPD) which is a low cost contactless payment IoT (Internet of things) device. It functions as a tokenized alternative to traditional magnetic stripe and smart payment cards. The TPD operates pairing with a companion app that runs on a mobile phone. The companion app is used to manage the TPD device via a Bluetooth BLE connection.

The EUT contains two interfaces for payment transactions: NFC and Magnetic Secure Transmission (MST). The MST consists of a H-bridge driving an inductor. The MST uses magnetic pulses generated by the inductor to induce payment tokens formatted as magnetic stripe card data, into the magnetic stripe reader of a point of sale terminal. The 13.56 MHz passive NFC tag uses load modulation to convey information to the POS terminal's NFC reader. Depending on the type of POS, either the NFC or the MST interface is used to make a payment. The mode selection is automatic. When the TPD detects the 13.56 MHz field of the NFC reader it enters the NFC mode and disables the MST transmitter. When no NFC field is detected, the TPD uses MST to send the payment token to the POS terminal.

The Bluetooth BLE of the EUT operates at frequency range of 2402MHz to 2480MHz. There are total 40 channels with 2MHz channel spacing. The applicant declared that only Bluetooth BLE is used in the product. The MST operates in the frequency range between 0.8 kHz to 5 kHz. The NFC passive tag operates at 13.56MHz.

The EUT is powered by an internal 3.7V rechargeable battery. The USB port is for charging internal battery purpose only.

Antenna Type: Internal, Integral

For electronic filing, the brief circuit description is saved with filename: descri.pdf.

#### 1.2 Related Submittal(s) Grants

This is a single application for certification of a transceiver.

## TEST REPORT

### 1.3 Test Methodology

Both AC mains line-conducted and radiated emission measurements were performed according to the procedures in ANSI C63.10 (2013). All radiated measurements were performed in an 3m Chamber. Preliminary scans were performed in the 3m Chamber only to determine worst case modes. All radiated tests were performed at an antenna to EUT distance of 3 meters, unless stated otherwise in the “**Justification Section**” of this Application.

### 1.4 Test Facility

The 3m Chamber and conducted measurement facility used to collect the radiated data is located at Workshop No. 3, G/F., World-Wide Industrial Centre, 43-47 Shan Mei Street, Fo Tan, Sha Tin, N.T., Hong Kong. This test facility and site measurement data have been placed on file with the FCC.

## TEST REPORT

### 2.0 SYSTEM TEST CONFIGURATION

#### 2.1 Justification

The system was configured for testing in a typical fashion (as a customer would normally use it), and in the confines as outlined in ANSI C63.10 (2013).

The device was powered by 3.7V Rechargeable battery and/or USB port (5VDC). Both powering method had been tested and worse-case data is shown in this report only (powered by USB port).

For maximizing emissions, the EUT was rotated through 360°, the antenna height was varied from 1 meter to 4 meters above the ground plane, and the antenna polarization was changed. This step by step procedure for maximizing emissions led to the data reported in Exhibit 3.0.

The rear of unit shall be flushed with the rear of the table.

The equipment under test (EUT) was configured for testing in a typical fashion (as a customer would normally use it). The EUT was mounted to a plastic stand if necessary and placed on the wooden turntable, which enabled the engineer to maximize emissions through its placement in the three orthogonal axes.

#### 2.2 EUT Exercising Software

The EUT exercise program (if any) used during radiated testing was designed to exercise the various system components in a manner similar to a typical use.

#### 2.3 Special Accessories

There are no special accessories necessary for compliance of this product.

#### 2.4 Measurement Uncertainty

When determining of the test conclusion, the Measurement Uncertainty of test has been considered.

#### 2.5 Support Equipment List and Description

1. 1 x USB cable with length of 0.6 meter long
2. LAN cable with length of of 2 meter long
3. HP Notebook (Adaptor Model: HSTNN-CA15)  
(Provided by Intertek)

## TEST REPORT

### 3.0 EMISSION RESULTS

Data is included of the worst case configuration (the configuration which resulted in the highest emission levels). A sample calculation, configuration photographs and data tables of the emissions are included.

#### 3.1 Field Strength Calculation

The field strength is calculated by adding the Antenna Factor and Cable Factor, and subtracting the Amplifier Gain (if any), Average Factor (optional) from the measured reading. The basic equation with a sample calculation is as follows:

$$FS = RA + AF + CF - AG - AV$$

where FS = Field Strength in dB $\mu$ V/m

RA = Receiver Amplitude (including preamplifier) in dB $\mu$ V

CF = Cable Attenuation Factor in dB

AF = Antenna Factor in dB

AG = Amplifier Gain in dB

AV = Average Factor in dB

In the following table(s), the reading shown on the data table reflects the preamplifier gain. An example for the calculations in the following table is as follows:

$$FS = RR + LF$$

where

FS = Field Strength in dB $\mu$ V/m

RR = RA - AG - AV in dB $\mu$ V

LF = CF + AF in dB

Assume a receiver reading of 52.0 dB $\mu$ V is obtained. The antenna factor of 7.4 dB and cable factor of 1.6 dB are added. The amplifier gain of 29 dB and average factor of 5 dB are subtracted, giving a field strength of 32 dB $\mu$ V/m. This value in dB $\mu$ V/m was converted to its corresponding level in  $\mu$ V/m.

$$RA = 52.0 \text{ dB}\mu\text{V/m}$$

$$AF = 7.4 \text{ dB}$$

$$CF = 1.6 \text{ dB}$$

$$AG = 29.0 \text{ dB}$$

$$AV = 5.0 \text{ dB}$$

$$FS = RR + LF$$

$$FS = 18 + 9 = 27 \text{ dB}\mu\text{V/m}$$

$$RR = 18.0 \text{ dB}\mu\text{V}$$

$$LF = 9.0 \text{ dB}$$

$$\text{Level in } \mu\text{V/m} = \text{Common Antilogarithm } [(27 \text{ dB}\mu\text{V/m})/20] = 22.4 \mu\text{V/m}$$



## TEST REPORT

### 3.2 Radiated Emission Configuration Photograph

The worst case in radiated emission was found at 696.552 MHz

For electronic filing, the worst case radiated emission configuration photographs are saved with filename: radiated photos.pdf.

### 3.3 Radiated Emission Data

The data on the following page lists the significant emission frequencies, the limit and the margin of compliance. Numbers with a minus sign are below the limit.

Judgment: Passed by 11.8 dB

### 3.4 Conducted Emission Configuration Photograph

The worst case in line-conducted emission was found at 0.159 MHz

For electronic filing, the worst case line-conducted configuration photographs are saved with filename: conducted photo.pdf.

### 3.5 Conducted Emission Data

For electronic filing, the graph and data table of conducted emission is saved with filename: conducted.pdf.

Judgment: Pass by 11.6 dB

**TEST REPORT**

**CONDUCTED EMISSION**

Model: SP-TPD02

Date of Test: March 18, 2018

Worst-Case Operating Mode: Bluetooth Operating

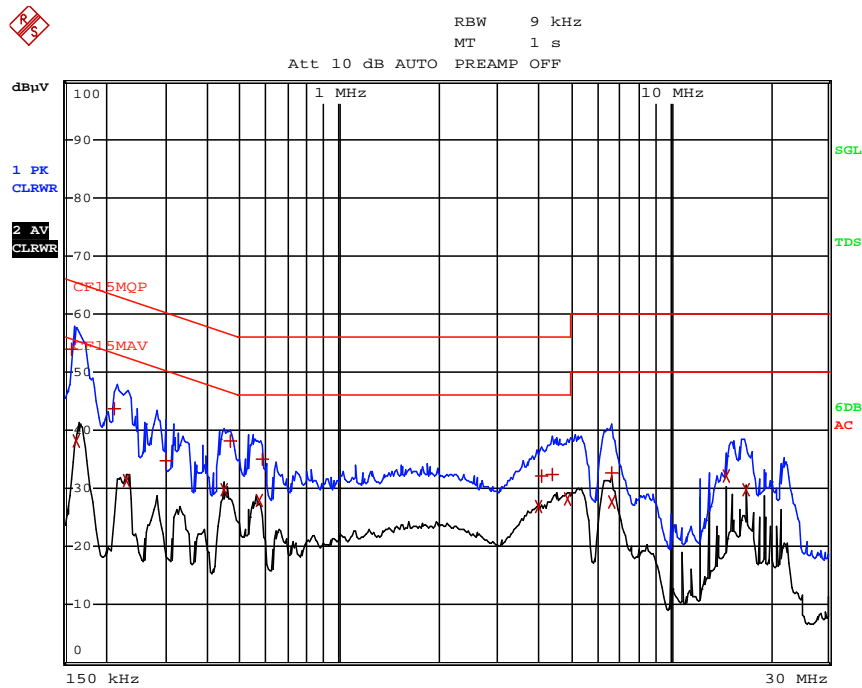

EDIT PEAK LIST (Final Measurement Results)

TRACE	FREQUENCY	LEVEL dBµV	DELTA	LIMIT dB
Trace1: CF15MQP				
Trace2: CF15MAV				
Trace3: ---				
TRACE	FREQUENCY	LEVEL dBµV	DELTA	LIMIT dB
1 Quasi Peak	159 kHz	53.94 N	-11.57	
2 CISPR Average	163.5 kHz	38.17 L1	-17.11	
1 Quasi Peak	213 kHz	43.71 L1	-19.37	
2 CISPR Average	231 kHz	31.35 L1	-21.05	
1 Quasi Peak	298.5 kHz	34.68 N	-25.60	
2 CISPR Average	447 kHz	29.85 N	-17.07	
1 Quasi Peak	465 kHz	38.20 N	-18.39	
2 CISPR Average	573 kHz	27.82 N	-18.17	
1 Quasi Peak	586.5 kHz	34.98 N	-21.01	
2 CISPR Average	4.0155 MHz	26.81 N	-19.18	
1 Quasi Peak	4.101 MHz	32.19 N	-23.80	
1 Quasi Peak	4.425 MHz	32.31 N	-23.68	
2 CISPR Average	4.8885 MHz	28.26 N	-17.73	
1 Quasi Peak	6.657 MHz	32.58 N	-27.41	
2 CISPR Average	6.666 MHz	27.59 N	-22.40	
2 CISPR Average	14.6805 MHz	32.03 L1	-17.96	
2 CISPR Average	17.0025 MHz	29.69 L1	-20.30	

Note: Measurement Uncertainty is ±4.2dB at a level of confidence of 95%.

## TEST REPORT

### RADIATED EMISSIONS

Model: SP-TPD02

Date of Test: March 18, 2018

Worst-Case Operating Mode: Transmitting

Table 1  
Pursuant to FCC Part 15 Section 15.249 Requirement

#### Lowest Channel

Polarization	Frequency (MHz)	Reading (dB $\mu$ V)	Pre-Amp Gain (dB)	Antenna Factor (dB)	Net at 3m - Peak (dB $\mu$ V/m)	Average Factor (dB)	Calculated at 3m (dB $\mu$ V/m)	Average Limit at 3m (dB $\mu$ V/m)	Margin (dB)
H	2402.000	100.4	33	29.4	96.8	49.9	46.9	94.0	-47.1
<b>H</b>	<b>4804.000</b>	<b>50.3</b>	<b>33</b>	<b>34.9</b>	<b>52.2</b>	<b>49.9</b>	<b>2.3</b>	<b>54.0</b>	<b>-51.7</b>
H	7206.000	57.1	33	37.9	62.0	49.9	12.1	54.0	-41.9
H	9608.000	42.4	33	40.4	49.8	49.9	-0.1	54.0	-54.1
<b>H</b>	<b>12010.000</b>	<b>44.1</b>	<b>33</b>	<b>40.5</b>	<b>51.6</b>	<b>49.9</b>	<b>1.7</b>	<b>54.0</b>	<b>-52.3</b>
H	14412.000	45.7	33	40.0	52.7	49.9	2.8	54.0	-51.2

Polarization	Frequency (MHz)	Reading (dB $\mu$ V)	Pre-Amp Gain (dB)	Antenna Factor (dB)	Net at 3m - Peak (dB $\mu$ V/m)	Peak Limit at 3m (dB $\mu$ V/m)	Margin (dB)
H	2402.000	100.4	33	29.4	96.8	114.0	-17.2
<b>H</b>	<b>4804.000</b>	<b>50.3</b>	<b>33</b>	<b>34.9</b>	<b>52.2</b>	<b>74.0</b>	<b>-21.8</b>
H	7206.000	57.1	33	37.9	62.0	74.0	-12.0
H	9608.000	42.4	33	40.4	49.8	74.0	-24.2
<b>H</b>	<b>12010.000</b>	<b>44.1</b>	<b>33</b>	<b>40.5</b>	<b>51.6</b>	<b>74.0</b>	<b>-22.4</b>
H	14412.000	45.7	33	40.0	52.7	74.0	-21.3

- NOTES:
1. Peak Detector Data unless otherwise stated.
  2. All measurements were made at 3 meters. Harmonic emissions not detected at the 3-meter distances were measured at 0.3-meter and an inverse proportional extrapolation was performed to compare the signal level to the 3-meter limit. No other harmonic emissions than those reported were detected at a test distance of 0.3-meter.
  3. Negative sign in the column shows value below limit.
  4. Horn antenna is used for the emission over 1000MHz.
  5. Emission (the row indicated by **bold italic**) within the restricted band meets the requirement of FCC Part 15 Section 15.205.
  6. Measurement Uncertainty is  $\pm 5.3$ dB at a level of confidence of 95%.

## TEST REPORT

Model: SP-TPD02

Date of Test: March 18, 2018

Worst-Case Operating Mode: Transmitting

Table 2  
Pursuant to FCC Part 15 Section 15.249 Requirement

### Middle Channel

Polarization	Frequency (MHz)	Reading (dB $\mu$ V)	Pre-Amp Gain (dB)	Antenna Factor (dB)	Net at 3m - Peak (dB $\mu$ V/m)	Average Factor (dB)	Calculated at 3m (dB $\mu$ V/m)	Average Limit at 3m (dB $\mu$ V/m)	Margin (dB)
H	2440.000	100.2	33	29.4	96.6	49.9	46.7	94.0	-47.3
<b>H</b>	<b>4880.000</b>	<b>52.7</b>	<b>33</b>	<b>34.9</b>	<b>54.6</b>	<b>49.9</b>	<b>4.7</b>	<b>54.0</b>	<b>-49.3</b>
<b>H</b>	<b>7320.000</b>	<b>53.4</b>	<b>33</b>	<b>37.9</b>	<b>58.3</b>	<b>49.9</b>	<b>8.4</b>	<b>54.0</b>	<b>-45.6</b>
H	9760.000	42.7	33	40.4	50.1	49.9	0.2	54.0	-53.8
<b>H</b>	<b>12200.000</b>	<b>43.9</b>	<b>33</b>	<b>40.5</b>	<b>51.4</b>	<b>49.9</b>	<b>1.5</b>	<b>54.0</b>	<b>-52.5</b>
H	14640.000	47.1	33	38.4	52.5	49.9	2.6	54.0	-51.4

Polarization	Frequency (MHz)	Reading (dB $\mu$ V)	Pre-Amp Gain (dB)	Antenna Factor (dB)	Net at 3m - Peak (dB $\mu$ V/m)	Peak Limit at 3m (dB $\mu$ V/m)	Margin (dB)
H	2440.000	100.2	33	29.4	96.6	114.0	-17.4
<b>H</b>	<b>4880.000</b>	<b>52.7</b>	<b>33</b>	<b>34.9</b>	<b>54.6</b>	<b>74.0</b>	<b>-19.4</b>
<b>H</b>	<b>7320.000</b>	<b>53.4</b>	<b>33</b>	<b>37.9</b>	<b>58.3</b>	<b>74.0</b>	<b>-15.7</b>
H	9760.000	42.7	33	40.4	50.1	74.0	-23.9
<b>H</b>	<b>12200.000</b>	<b>43.9</b>	<b>33</b>	<b>40.5</b>	<b>51.4</b>	<b>74.0</b>	<b>-22.6</b>
H	14640.000	47.1	33	38.4	52.5	74.0	-21.5

- NOTES:
1. Peak Detector Data unless otherwise stated.
  2. All measurements were made at 3 meters. Harmonic emissions not detected at the 3-meter distances were measured at 0.3-meter and an inverse proportional extrapolation was performed to compare the signal level to the 3-meter limit. No other harmonic emissions than those reported were detected at a test distance of 0.3-meter.
  3. Negative sign in the column shows value below limit.
  4. Horn antenna is used for the emission over 1000MHz.
  5. Emission (the row indicated by **bold italic**) within the restricted band meets the requirement of FCC Part 15 Section 15.205.
  6. Measurement Uncertainty is  $\pm 5.3$ dB at a level of confidence of 95%.

## TEST REPORT

Model: SP-TPD02

Date of Test: March 18, 2018

Worst-Case Operating Mode: Transmitting

Table 3  
Pursuant to FCC Part 15 Section 15.249 Requirement

### Highest Channel

Polarization	Frequency (MHz)	Reading (dBμV)	Pre-Amp Gain (dB)	Antenna Factor (dB)	Net at 3m - Peak (dBμV/m)	Average Factor (dB)	Calculated at 3m (dBμV/m)	Average Limit at 3m (dBμV/m)	Margin (dB)
H	2480.000	100.4	33	29.4	96.8	49.9	46.9	94.0	-47.1
<b>H</b>	<b>4960.000</b>	<b>50.0</b>	<b>33</b>	<b>34.9</b>	<b>51.9</b>	<b>49.9</b>	<b>2.0</b>	<b>54.0</b>	<b>-52.0</b>
<b>H</b>	<b>7440.000</b>	<b>54.3</b>	<b>33</b>	<b>37.9</b>	<b>59.2</b>	<b>49.9</b>	<b>9.3</b>	<b>54.0</b>	<b>-44.7</b>
H	9920.000	42.2	33	40.4	49.6	49.9	-0.3	54.0	-54.3
<b>H</b>	<b>12400.000</b>	<b>44.2</b>	<b>33</b>	<b>40.5</b>	<b>51.7</b>	<b>49.9</b>	<b>1.8</b>	<b>54.0</b>	<b>-52.2</b>
H	14880.000	47.6	33	38.4	53.0	49.9	3.1	54.0	-50.9

Polarization	Frequency (MHz)	Reading (dBμV)	Pre-Amp Gain (dB)	Antenna Factor (dB)	Net at 3m - Peak (dBμV/m)	Peak Limit at 3m (dBμV/m)	Margin (dB)
H	2480.000	100.4	33	29.4	96.8	114.0	-17.2
<b>H</b>	<b>4960.000</b>	<b>50.0</b>	<b>33</b>	<b>34.9</b>	<b>51.9</b>	<b>74.0</b>	<b>-22.1</b>
<b>H</b>	<b>7440.000</b>	<b>54.3</b>	<b>33</b>	<b>37.9</b>	<b>59.2</b>	<b>74.0</b>	<b>-14.8</b>
H	9920.000	42.2	33	40.4	49.6	74.0	-24.4
<b>H</b>	<b>12400.000</b>	<b>44.2</b>	<b>33</b>	<b>40.5</b>	<b>51.7</b>	<b>74.0</b>	<b>-22.3</b>
H	14880.000	47.6	33	38.4	53.0	74.0	-21.0

- NOTES:
1. Peak Detector Data unless otherwise stated.
  2. All measurements were made at 3 meters. Harmonic emissions not detected at the 3-meter distances were measured at 0.3-meter and an inverse proportional extrapolation was performed to compare the signal level to the 3-meter limit. No other harmonic emissions than those reported were detected at a test distance of 0.3-meter.
  3. Negative sign in the column shows value below limit.
  4. Horn antenna is used for the emission over 1000MHz.
  5. Emission (the row indicated by **bold italic**) within the restricted band meets the requirement of FCC Part 15 Section 15.205.
  6. Measurement Uncertainty is  $\pm 5.3$ dB at a level of confidence of 95%.

## TEST REPORT

Model: SP-TPD02

Date of Test: March 18, 2018

Worst-Case Operating Mode: Bluetooth Operating

Table 4  
Pursuant to FCC Part 15 Section 15.209 Requirement

Polarization	Frequency (MHz)	Reading (dB $\mu$ V)	Pre-amp (dB)	Antenna Factor (dB)	Net at 3m (dB $\mu$ V/m)	Limit at 3m (dB $\mu$ V/m)	Margin (dB)
H	31.186	26.4	16	10.0	20.4	40.0	-19.6
<b>V</b>	<b>119.186</b>	<b>24.0</b>	<b>16</b>	<b>14.0</b>	<b>22.0</b>	<b>43.5</b>	<b>-21.5</b>
<b>V</b>	<b>131.634</b>	<b>24.5</b>	<b>16</b>	<b>14.0</b>	<b>22.5</b>	<b>43.5</b>	<b>-21.0</b>
V	395.528	17.8	16	25.0	26.8	46.0	-19.2
H	569.752	20.0	16	28.0	32.0	46.0	-14.0
H	696.552	20.2	16	30.0	34.2	46.0	-11.8

- NOTES:
1. Peak Detector Data unless otherwise stated.
  2. All measurements were made at 3 meters. Harmonic emissions not detected at the 3-meter distances were measured at 0.3-meter and an inverse proportional extrapolation was performed to compare the signal level to the 3-meter limit. No other harmonic emissions than those reported were detected at a test distance of 0.3-meter.
  3. Negative sign in the column shows value below limit.
  4. Horn antenna is used for the emission over 1000MHz.
  5. Emission (the row indicated by **bold italic**) within the restricted band meets the requirement of FCC Part 15 Section 15.205.
  6. Measurement Uncertainty is  $\pm 5.3$ dB at a level of confidence of 95%.

## TEST REPORT

### **4.0 EQUIPMENT PHOTOGRAPHS**

For electronic filing, the photographs are saved with filename: external photos.pdf and internal photos.pdf.

### **5.0 PRODUCT LABELLING**

For electronics filing, the FCC ID label artwork and the label location are saved with filename: label.pdf.

### **6.0 TECHNICAL SPECIFICATIONS**

For electronic filing, the block diagram and schematic of the tested EUT are saved with filename: block.pdf and circuit.pdf respectively.

### **7.0 INSTRUCTION MANUAL**

For electronic filing, a preliminary copy of the Instruction Manual is saved with filename: manual.pdf.

This manual will be provided to the end-user with each unit sold/leased in the United States .

## TEST REPORT

### 8.0 MISCELLANEOUS INFORMATION

The miscellaneous information includes details of the test procedure and measured bandwidth / calculation of factor such as pulse desensitization and averaging factor (calculation and timing diagram).

#### 8.1 Radiated Emission on the Bandedge

From the following plots, they show that the fundamental emissions are confined in the specified band (2400MHz to 2483.5MHz). In case of the fundamental emissions are within two standard bandwidths from the bandedge, the delta measurement technique is used for determining bandedge compliance. Standard bandwidth is the bandwidth specified by ANSI C63.10 (2013) for frequency being measured.

Emissions radiated outside of the specified frequency bands, except harmonics, are attenuated by 50dB below the level of the fundamental or to the general radiated emissions limits in Section 15.209, whichever is the lesser attenuation, which meet the requirement of part 15.249(d).



**TEST REPORT**

**PEAK MEASUREMENT**

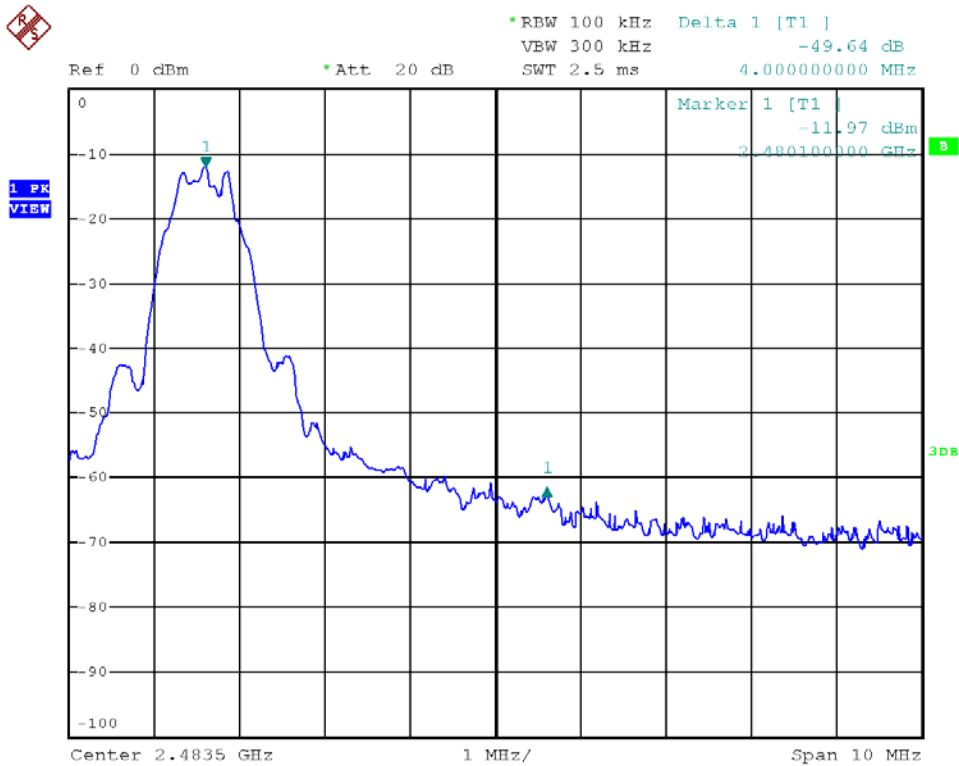
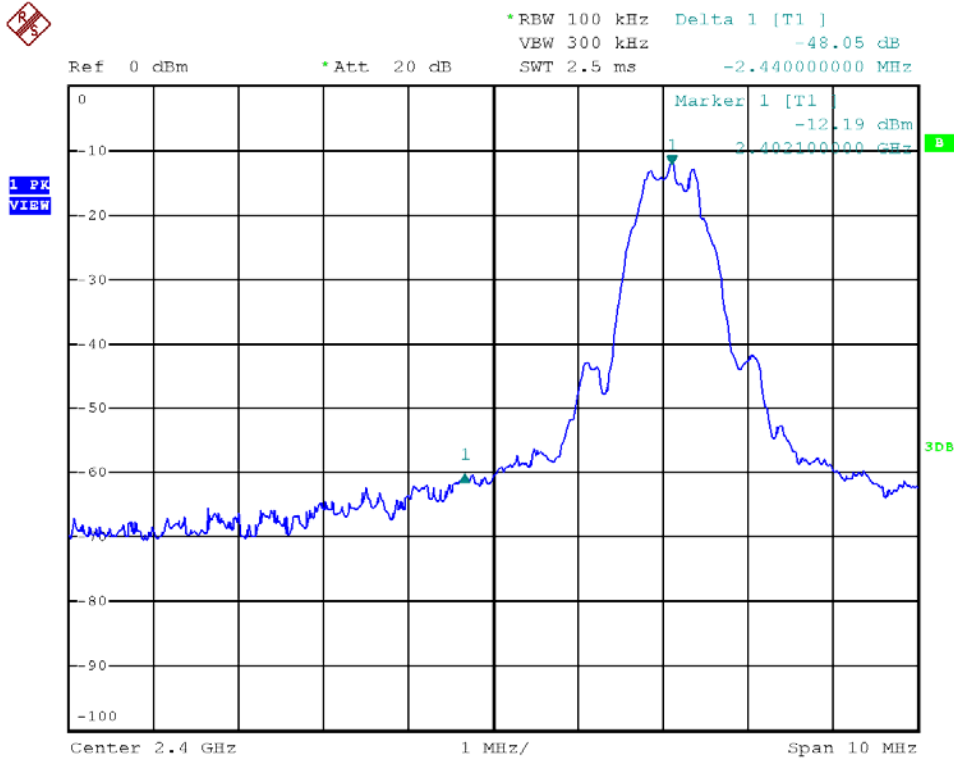

## TEST REPORT

### PEAK MEASUREMENT

Bandedge compliance is determined by applying marker-delta method, i.e. (Bandedge Plot).

Lower bandedge

Peak Resultant field strength = Fundamental emissions (peak value) – delta from the plot

$$=96.8 \text{ dB}\mu\text{V/m} - 48.1 \text{ dB}$$

$$=48.7 \text{ dB}\mu\text{V/m}$$

Average Resultant field strength = Fundamental emissions (average value) – delta from the plot

$$=46.9 \text{ dB}\mu\text{V/m} - 48.1 \text{ dB}\mu\text{V/m}$$

$$=-1.2 \text{ dB}\mu\text{V/m}$$

Upper bandedge

Peak Resultant field strength = Fundamental emissions (peak value) – delta from the plot

$$=96.8 \text{ dB}\mu\text{V/m} - 49.6 \text{ dB}$$

$$=47.2 \text{ dB}\mu\text{V/m}$$

Average Resultant field strength = Fundamental emissions (average value) – delta from the plot

$$=46.9 \text{ dB}\mu\text{V/m} - 49.6 \text{ dB}$$

$$=-2.7 \text{ dB}\mu\text{V/m}$$

The resultant field strength meets the general radiated emission limit in Section 15.209, which does not exceed 74 dB $\mu$ V/m (Peak Limit) and 54 dB $\mu$ V/m (Average Limit).

## TEST REPORT

### 8.2 Discussion of Pulse Desensitization

Pulse desensitivity is not applicable for this device. The effective period (Teff) is approximately 300 $\mu$ s for a digital "1" bit which illustrated on technical specification, with a resolution bandwidth (3dB) of 3MHz, so the pulse desensitivity factor is 0dB.

### 8.3 Calculation of Average Factor

The duty cycle is simply the on-time divided by the period:

The duration of one cycle = 100 ms

Effective period of the cycle = 320  $\mu$ s

DC = 320  $\mu$ s / 100 ms = 0.0032

Therefore, the averaging factor is found by  $20\log 0.0032 = -49.9$  dB.

## TEST REPORT

### AVERAGE FACTOR

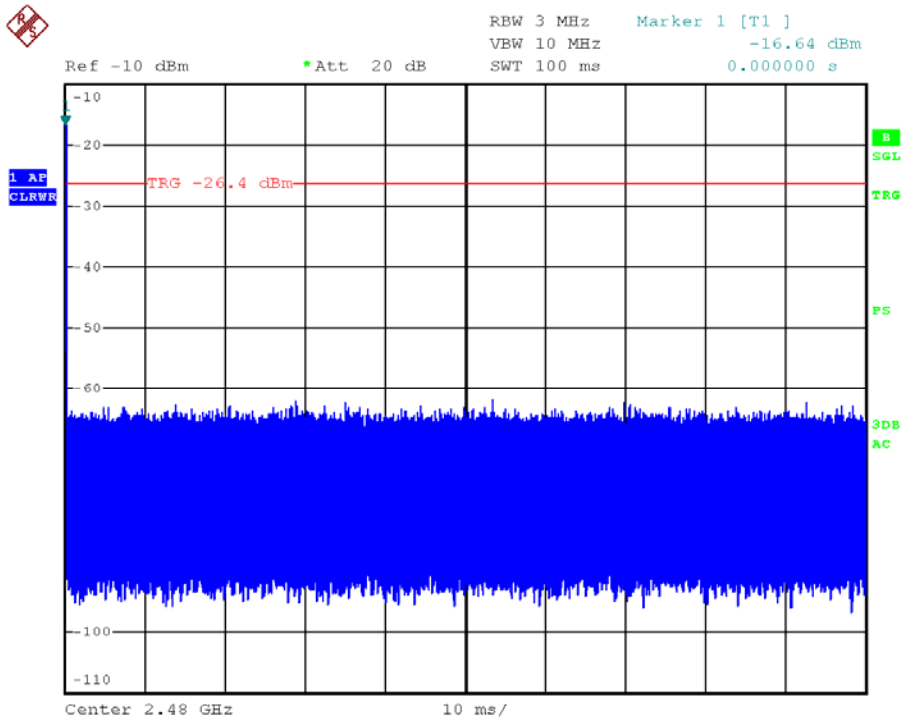
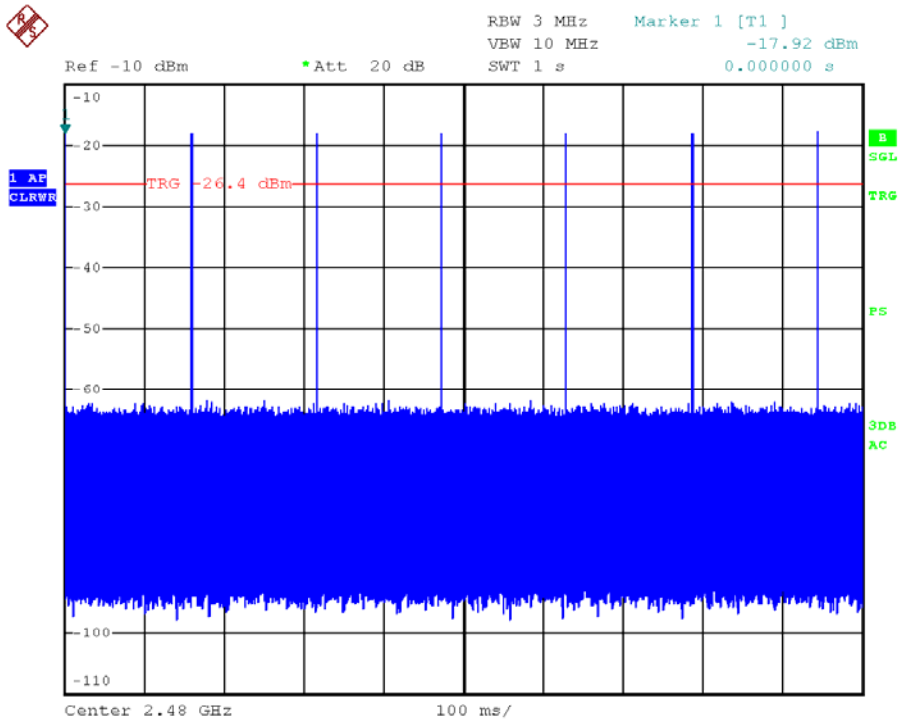

## TEST REPORT

### AVERAGE FACTOR

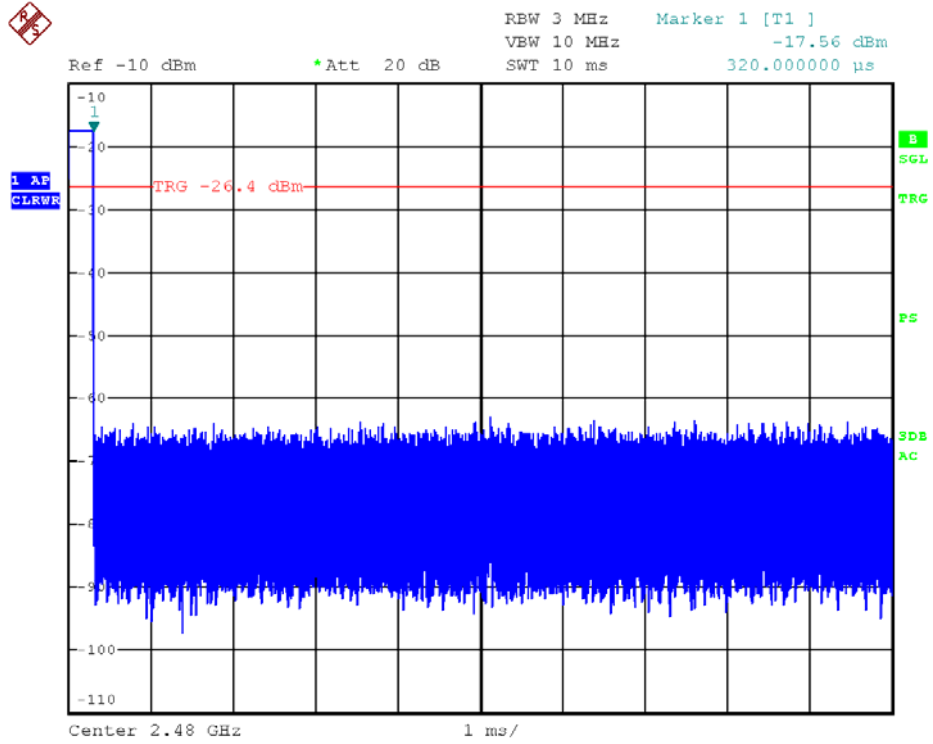

## TEST REPORT

### 8.4 Emissions Test Procedures

The following is a description of the test procedure used by Intertek Testing Services Hong Kong Ltd. in the measurements of transmitter operating under the Part 15, Subpart C rules.

The transmitting equipment under test (EUT) is placed on a wooden turntable which is four feet in diameter and approximately 0.8m in height above the ground plane for emission measurement at or below 1GHz and 1.5m in height above the ground plane for emission measurement above 1GHz. During the radiated emissions test, the turntable is rotated and any cables leaving the EUT are manipulated to find the configuration resulting in maximum emissions. The EUT is adjusted through all three orthogonal axis to obtain maximum emission levels. The antenna height and polarization are also varied during the testing to search for maximum signal levels. The height of the antenna is varied from one to four meters.

Detector function for radiated emissions is in peak mode. Average readings, when required, are taken by measuring the duty cycle of the equipment under test and subtracting the corresponding amount in dB from the measured peak readings. A detailed description for the calculation of the average factor can be found in Exhibit 8.3.

The frequency range scanned is from the lowest radio frequency signal generated in the device which is greater than 9 kHz to the tenth harmonic of the highest fundamental frequency or 40 GHz, whichever is lower. For line conducted emissions, the range scanned is 150 kHz to 30 MHz.

## TEST REPORT

### 8.4 Emissions Test Procedures (cont'd)

The EUT is warmed up for 15 minutes prior to the test.

AC power to the unit is varied from 85% to 115% nominal and variation in the fundamental emission field strength is recorded. If battery powered, a new, fully charged battery is used.

Conducted measurements were made as described in ANSI C63.10 (2013).

The IF bandwidth used for measurement of radiated signal strength was 100 kHz or greater when frequency is below 1000 MHz. Where pulsed transmissions of short enough pulse duration warrant, a greater bandwidth is selected according to the recommendations of Hewlett Packard Application Note 150-2. A discussion of whether pulse desensitivity is applicable to this unit is included in this report (See Exhibit 8.1). Above 1000 MHz, a resolution bandwidth of 3 MHz is used.

Transmitter measurements are normally conducted at a measurement distance of three meters. However, to assure low enough noise floor in the forbidden bands and above 1 GHz, signals are acquired at a distance of one meter or less. All measurements are extrapolated to three meters using inverse scaling, unless otherwise reported. Measurements taken at a closer distance are so marked.

## TEST REPORT

### 8.4.1 Radiated Emission Test Setup

The figure below shows the test setup, which is utilized to make these measurements.

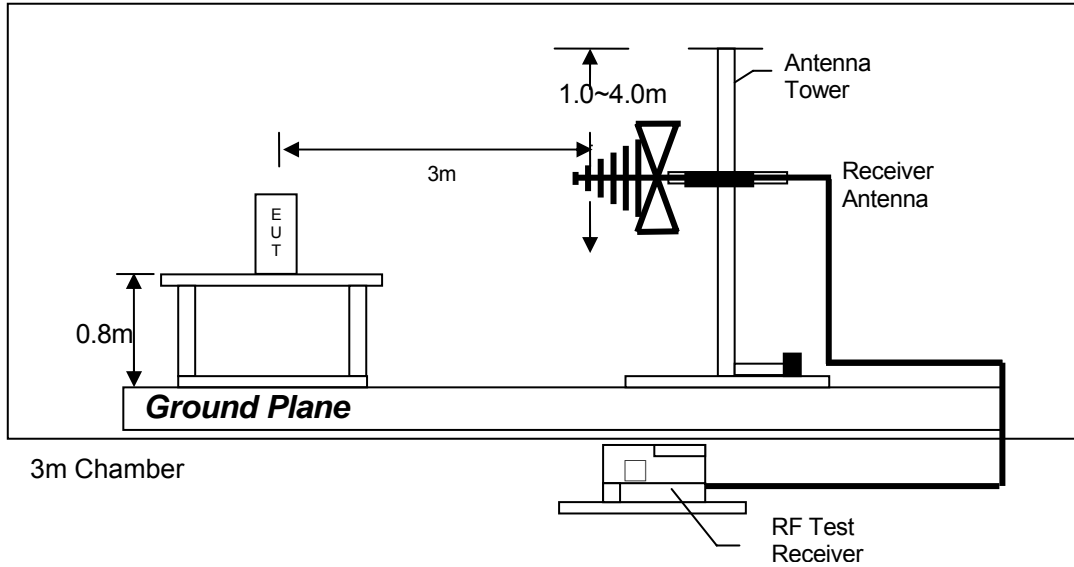

Test setup of radiated emissions up to 1GHz

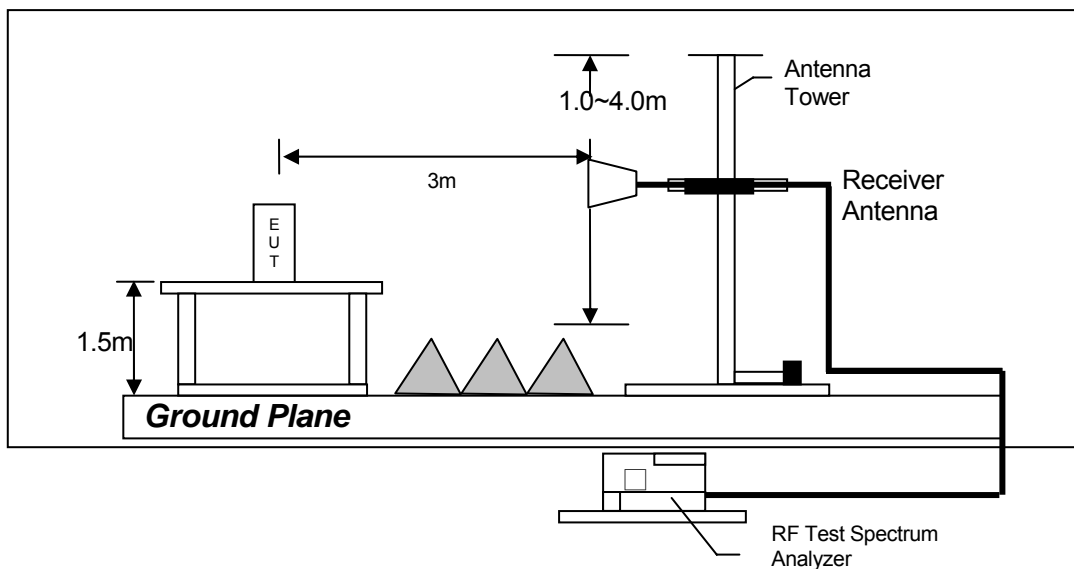

Test setup of radiated emissions above 1GHz



## TEST REPORT

### 8.4.2 Conducted Emission Test Procedures

For tabletop equipment, the EUT along with its peripherals were placed on a 1.0m(W)×1.5m(L) and 0.8m in height wooden table. For floor-standing equipment, the EUT and all cables were insulated, if required, from the ground plane by up to 12 mm of insulating material. The EUT was adjusted to maintain a 0.4 meter space from a vertical reference plane. The EUT was connected to power mains through a line impedance stabilization network (LISN), which provided 50 ohm coupling impedance for measuring instrument and the chassis ground was bounded to the horizontal ground plane of shielded room. The excess power cable between the EUT and the LISN was bundled.

All connecting cables of EUT and peripherals were moved to find the maximum emission.

### 8.4.3 Conducted Emission Test Setup

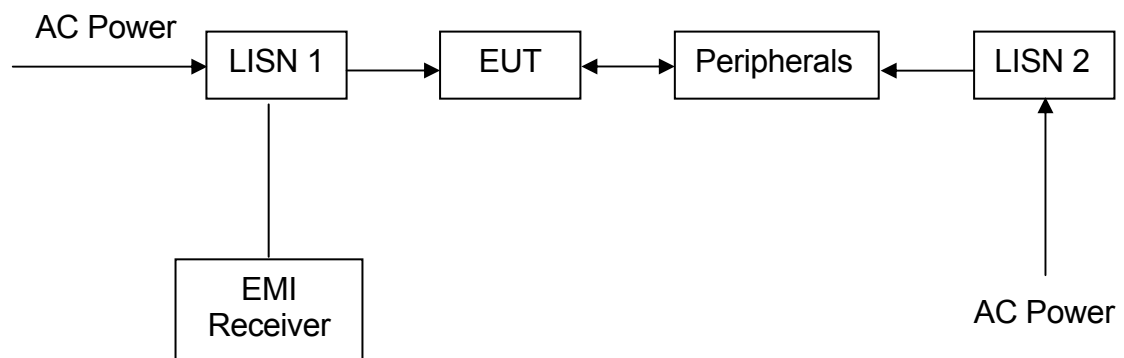

## TEST REPORT

### 9.0 CONFIDENTIALITY REQUEST

For electronic filing, a preliminary copy of the confidentiality request is saved with filename: request.pdf.

### 10.0 EQUIPMENT LIST

#### 1) Radiated Emissions Test

Equipment	Emi Test Receiver	Biconical Antenna	Log Periodic Antenna
Registration No.	EW-2500	EW-3512	EW-1042
Manufacturer	ROHDESCHWARZ	EMCO	EMCO
Model No.	ESCI	3104C	3148
Calibration Date	Oct. 13, 2017	Nov. 16, 2016	Jun. 19, 2017
Calibration Due Date	Oct. 13, 2018	May 16, 2018	Dec. 19, 2018

Equipment	Spectrum Analyzer	Pyramidal Horn Antenna	Double Ridged Guide Antenna
Registration No.	EW-2253	EW-0905	EW-1015
Manufacturer	ROHDESCHWARZ	EMCO	EMCO
Model No.	FSP40	3160-09	3115
Calibration Date	Jul. 24, 2017	Aug. 18, 2017	Nov. 17, 2017
Calibration Due Date	Jul. 24, 2018	Feb. 18, 2019	May. 17, 2019

Equipment	Active Loop H-field (9kHz to 30MHz)	RF Cable 9kHz to 1000MHz	RF Cable 14m (1GHz to 26.5GHz)
Registration No.	EW-3326	EW-3170	EW-2781
Manufacturer	EMCO	N/A	GREATBILLION
Model No.	6502	9kHz to 1000MHz	SMA m/SHF5MPU /SMA m ra14m,26G
Calibration Date	Sep. 27, 2017	Mar. 20, 2017	Sep. 25, 2017
Calibration Due Date	Mar. 27, 2019	Mar. 20, 2018	Sep. 25, 2018

Equipment	RF Pre-Amplifier 3 Pcs (9kHz To 40GHz)	Notch Filter (cutoff frequency 2.4GHz to 2.5GHz)
Registration No.	EW-3006	EW-2213
Manufacturer	SCHWARZBECK	MICROTRONICS
Model No.	BBV 9718	BRM50701-02
Calibration Date	Mar. 23, 2017	May. 26, 2017
Calibration Due Date	Mar. 23, 2018	May. 26, 2018

## TEST REPORT

### 2) Conducted Emissions Test

Equipment	EMI Test Receiver	RF Cable 9kHz to 1000MHz	Artificial Mains Network
Registration No.	EW-2500	EW-3170	EW-0192
Manufacturer	ROHDESCHWARZ	N/A	ROHDESCHWARZ
Model No.	ESCI	9kHz to 1000MHz	ESH3-Z5
Calibration Date	Oct. 13, 2017	Mar. 20, 2017	Oct. 27, 2017
Calibration Due Date	Oct. 13, 2018	Mar. 20, 2018	Aug. 25, 2018

### 3) Bandedge/Bandwidth Measurement

Equipment	RF Cable (Up To 40GHz)	Spectrum Analyzer
Registration No.	EW-2701	EW-2253
Manufacturer	N/A	ROHDESCHWARZ
Model No.	SMA-M to SMA-M	FSP40
Calibration Date	Apr. 13, 2017	Jul. 24, 2017
Calibration Due Date	Apr. 13, 2018	Jul. 24, 2018

**END OF TEST REPORT**