

## **Certification Test Report**

**FCC ID: 2AIGCWFB002**

**FCC Rule Part: 15.247**

**ACS Report Number: 16-0222.W06.2A**

Manufacturer: Mitsubishi Electric US, Inc.  
Model: PAC-USWHS002-WF-1

Test Begin Date: May 27, 2016  
Test End Date: June 14, 2016

Report Issue Date: July 11, 2016



FOR THE SCOPE OF ACCREDITATION UNDER Certificate Number: AT-2021

This report must not be used by the client to claim product certification, approval, or endorsement by ANAB, NIST, or any agency of the Federal Government.

**Prepared by:**

A handwritten signature in black ink, appearing to read "R McGann".

**Ryan McGann**  
Wireless Program Manager  
Advanced Compliance Solutions, Inc.

**Reviewed by:**

A handwritten signature in black ink, appearing to read "Thierry Jean-Charles".

**Thierry Jean-Charles**  
EMC Engineer  
Advanced Compliance Solutions, Inc.

This test report shall not be reproduced except in full. This report may be reproduced in part with prior written consent of ACS, Inc. The results contained in this report are representative of the sample(s) submitted for evaluation.

**This report contains 20 pages**

# TABLE OF CONTENTS

<b>1</b>	<b>GENERAL</b>	<b>3</b>
1.1	PURPOSE	3
1.2	PRODUCT DESCRIPTION	3
1.3	TEST METHODOLOGY AND CONSIDERATIONS	3
<b>2</b>	<b>TEST FACILITIES</b>	<b>4</b>
2.1	LOCATION	4
2.2	LABORATORY ACCREDITATIONS/RECOGNITIONS/CERTIFICATIONS	4
2.3	RADIATED EMISSIONS TEST SITE DESCRIPTION	5
2.3.1	<i>Semi-Anechoic Chamber Test Site</i>	5
2.3.2	<i>Open Area Tests Site (OATS)</i>	6
2.4	CONDUCTED EMISSIONS TEST SITE DESCRIPTION	7
<b>3</b>	<b>APPLICABLE STANDARD REFERENCES</b>	<b>7</b>
<b>4</b>	<b>LIST OF TEST EQUIPMENT</b>	<b>8</b>
<b>5</b>	<b>SUPPORT EQUIPMENT</b>	<b>9</b>
<b>6</b>	<b>EQUIPMENT UNDER TEST SETUP BLOCK DIAGRAM</b>	<b>9</b>
<b>7</b>	<b>SUMMARY OF TESTS</b>	<b>10</b>
7.1	ANTENNA REQUIREMENT – FCC 15.203	10
7.2	POWER LINE CONDUCTED EMISSIONS – FCC 15.207, ISED CANADA: RSS-GEN 8.8	10
7.2.1	<i>Measurement Procedure</i>	10
7.2.2	<i>Measurement Results</i>	10
7.3	6dB / 99% BANDWIDTH – FCC 15.247(A)(2), ISED CANADA: RSS-247 5.2(1)	12
7.3.1	<i>Measurement Procedure</i>	12
7.3.2	<i>Measurement Results</i>	12
7.4	FUNDAMENTAL EMISSION OUTPUT POWER – FCC 15.247(B)(3), ISED CANADA: RSS-247 5.4(4)	14
7.4.1	<i>Measurement Procedure</i>	14
7.4.2	<i>Measurement Results</i>	14
7.5	EMISSION LEVELS – FCC 15.247(D), 15.205, 15.209; ISED CANADA: RSS-247 5.5, RSS-GEN 8.9/8.10	15
7.5.1	<i>Emissions into Non-restricted Frequency Bands</i>	15
7.5.1.1	<i>Measurement Procedure</i>	15
7.5.1.2	<i>Measurement Results</i>	15
7.5.2	<i>Emissions into Restricted Frequency Bands</i>	17
7.5.2.1	<i>Measurement Procedure</i>	17
7.5.2.2	<i>Duty Cycle Correction</i>	17
7.5.2.3	<i>Measurement Results</i>	17
7.5.2.4	<i>Sample Calculation</i>	18
7.6	MAXIMUM POWER SPECTRAL DENSITY IN THE FUNDAMENTAL EMISSION – FCC 15.247(E) ISED CANADA: RSS-247 5.2(2)	19
7.6.1	<i>Measurement Procedure</i>	19
7.6.2	<i>Measurement Results</i>	19
<b>8</b>	<b>CONCLUSION</b>	<b>20</b>

**1 GENERAL**

**1.1 Purpose**

The purpose of this report is to demonstrate compliance with Part 15 Subpart C of the FCC's Code of Federal Regulations.

**1.2 Product Description**

The PAC-USWHS002-WF-1 WiFi-BLE adapter wirelessly monitors and controls a MEUS HVAC unit via WiFi link. This device communicates wirelessly using either 802.11b/g/n WiFi mode or Bluetooth Smart (i.e. BLE) mode.

This report addresses the Bluetooth Low Energy transceiver only.

Technical Information:

<b>Detail</b>	<b>Description</b>
Frequency Range	2402 – 2480 MHz
Number of Channels	40
Modulation Format	GFSK
Operating Voltage	12Vdc
Antenna Type / Gain	Inverted-F Antenna / 3.3dBi gain

Manufacturer Information:  
 Mitsubishi Electric US, Inc.  
 1340 Satellite Blvd.  
 Suwanee, GA 30024

EUT Serial Numbers: ACS #3 (RF Conducted), ACS #5 (Radiated Emissions / Power line Conducted Emissions)

Test Sample Condition: The test samples were provided in good working order with no visible defects.

**1.3 Test Methodology and Considerations**

All modes of operation, including all available data rates, were evaluated. The data presented in this report represents the worst case where applicable.

For Radiated Emissions, the EUT was programmed to generate a continuously modulated signal on each channel investigated. The EUT was evaluated in three orthogonal orientations. The worst case orientation was X-orientation. See test setup photos for more information.

For RF Conducted Emissions, the EUT was programmed to generate a continuously modulated signal on each channel investigated. The EUT was modified with an u.fl antenna connector to facilitate connection to the test equipment.

For Power Line Conducted Emissions, the EUT was tested with a representative host evaporating unit. See the block diagram and test setup photos for more information.

Power setting during test: 0 dBm

## **2 TEST FACILITIES**

### **2.1 Location**

The radiated and conducted emissions test sites are located at the following address:

Advanced Compliance Solutions  
5015 B.U. Bowman Drive  
Buford, GA 30518  
Phone: (770) 831-8048  
Fax: (770) 831-8598

### **2.2 Laboratory Accreditations/Recognitions/Certifications**

ACS is accredited to ISO/IEC 17025 by the ANSI-ASQ National Accreditation Board/ANAB accreditation program, and has been issued certificate number AT-2021 in recognition of this accreditation. Unless otherwise specified, all tests methods described within this report are covered under the ISO/IEC 17025 scope of accreditation.

The Semi-Anechoic Chamber Test Site, Open Area Test Site (OATS) and Conducted Emissions Site have been fully described, submitted to, and accepted by the FCC, ISED Canada and the Japanese Voluntary Control Council for Interference by information technology equipment.

FCC Registration Number: 391271

ISED Canada Lab Code: IC 4175A

VCCI Member Number: 1831

- VCCI OATS Registration Number R-1526
- VCCI Conducted Emissions Site Registration Number: C-1608

### 2.3 Radiated Emissions Test Site Description

#### 2.3.1 Semi-Anechoic Chamber Test Site

The Semi-Anechoic Chamber Test Site consists of a 20' x 30' x 18' shielded enclosure. The chamber is lined with Toyo Ferrite Grid Absorber, model number FFG-1000. The ferrite tile grid is 101 x 101 x 19mm thick and weighs approximately 550 grams. These tiles are mounted on steel panels and installed directly on the inner walls of the chamber.

The turntable is 150cm in diameter and is located 160cm from the back wall of the chamber. The chamber is grounded via 1 - 8' copper ground rod, installed at the center of the back wall, it is bound to the ground plane using 3/4" stainless steel braided cable.

The turntable is all steel, flush mounted table installed in an all steel frame. The table is remotely operated from inside the control room located 25' from the range. The turntable is electrically bonded to the surrounding ground plane via steel fingers installed on the edge of the turn table. The steel fingers make constant contact with the ground plane during operation.

Behind the turntable is a 3' x 6' x 4' deep shielded pit used for support equipment if necessary. The pit is equipped with 1 - 4" PVC chases from the turntable to the pit that allow for cabling to the EUT if necessary. The underside of the turntable can be accessed from the pit so cables can be supplied to the EUT from the pit.

A diagram of the Semi-Anechoic Chamber Test Site is shown in Figure 2.3-1 below:

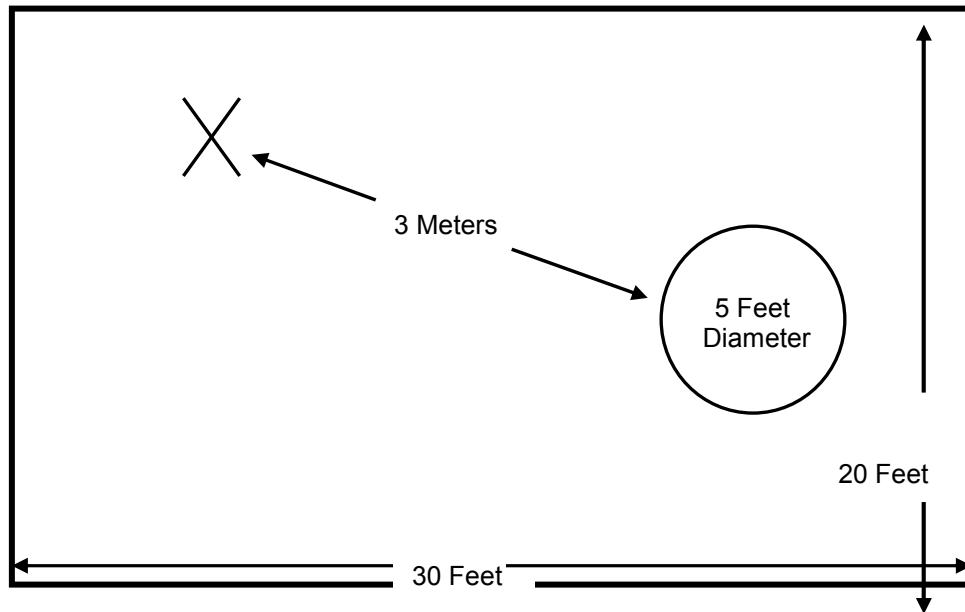

Figure 2.3-1: Semi-Anechoic Chamber Test Site

**2.3.2 Open Area Tests Site (OATS)**

The open area test site consists of a 40' x 66' concrete pad covered with a perforated electro-plated galvanized sheet metal. The perforations in the sheet metal are 1/8" holes that are staggered every 3/16". The individual sheets are placed to overlap each other by 1/4" and are riveted together to provide a continuous seam. Rivets are spaced every 3" in a 3 x 20 meter perimeter around the antenna mast and EUT area. Rivets in the remaining area are spaced as necessary to properly secure the ground plane and maintain the electrical continuity.

The entire ground plane extends 12' beyond the turntable edge and 16' beyond the antenna mast when set to a 10 meter measurement distance. The ground plane is grounded via 4 - 8' copper ground rods, each installed at a corner of the ground plane and bound to the ground plane using 3/4" stainless steel braided cable.

The turntable is an all aluminum 10' flush mounted table installed in an all aluminum frame. The table is remotely operated from inside the control room located 40' from the range. The turntable is electrically bonded to the surrounding ground plane via steel fingers installed on the edge of the turn table. The steel fingers make constant contact with the ground plane during operation.

Adjacent to the turntable is a 7' x 7' square and 4' deep concrete pit used for support equipment if necessary. The pit is equipped with 5 - 4" PVC chases from the pit to the control room that allow for cabling to the EUT if necessary. The underside of the turntable can be accessed from the pit so cables can be supplied to the EUT from the pit. The pit is covered with 2 sheets of 1/4" diamond style re-enforced steel sheets. The sheets are painted to match the perforated steel ground plane; however the underside edges have been masked off to maintain the electrical continuity of the ground plane. All reflecting objects are located outside of the ellipse defined in ANSI C63.4.

A diagram of the Open Area Test Site is shown in Figure 2.3-2 below:

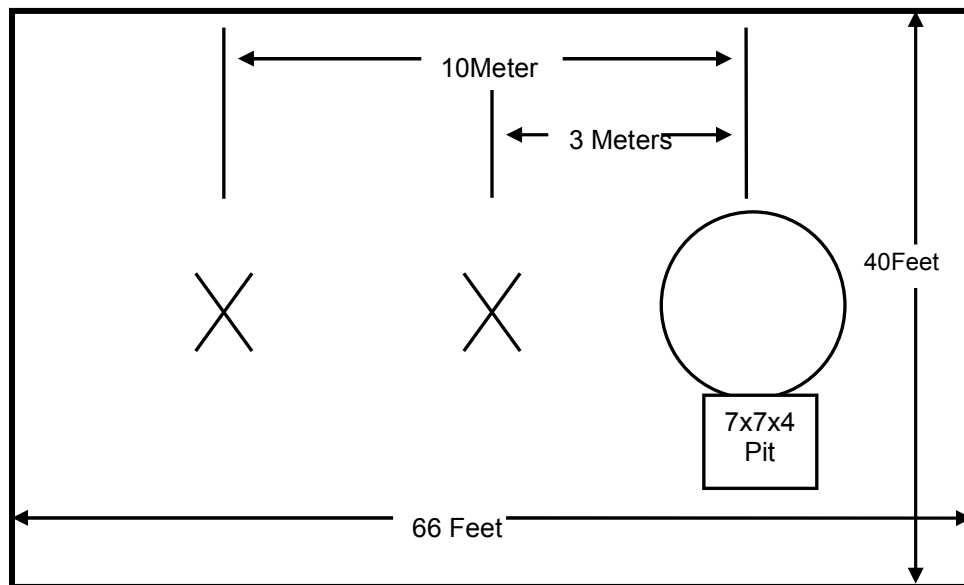

**Figure 2.3-2: Open Area Test Site**

## 2.4 Conducted Emissions Test Site Description

The AC mains conducted EMI site is located in the main EMC lab. It consists of an 8' x 8' solid aluminum horizontal ground reference plane (GRP) bonded every 3" to an 8' X 8' vertical ground plane.

The site is of sufficient size to test table top and floor standing equipment in accordance with section 6.1.4 of ANSI C63.4.

A diagram of the room is shown below in figure 4.1.3-1:

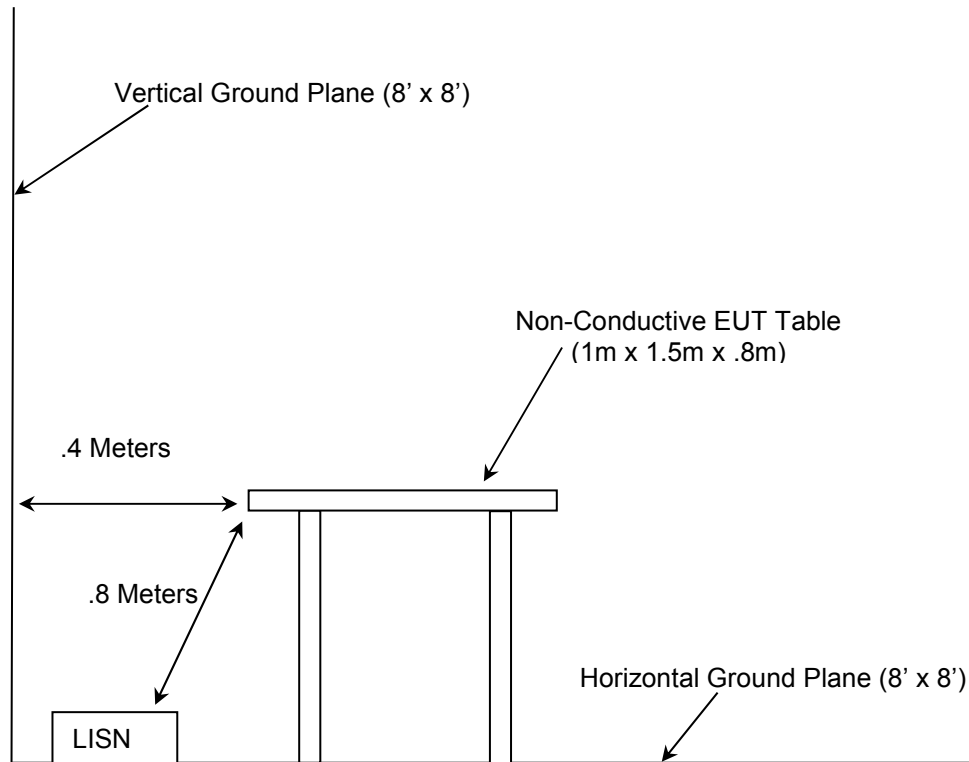

Figure 2.4-1: AC Mains Conducted EMI Site

## 3 APPLICABLE STANDARD REFERENCES

The following standards were used:

- ❖ ANSI C63.10-2013: American National Standard of Procedures for Compliance Testing of Unlicensed Wireless Devices
- ❖ US Code of Federal Regulations (CFR): Title 47, Part 2, Subpart J: Equipment Authorization Procedures, 2016
- ❖ US Code of Federal Regulations (CFR): Title 47, Part 15, Subpart C: Radio Frequency Devices, Intentional Radiators, 2016
- ❖ FCC KDB 558074 D01 DTS Meas Guidance v03r05 - Guidance for Performing Compliance Measurements on Digital Transmission Systems (DTS) Operating Under §15.247, April 8, 2016.
- ❖ ISED Canada Radio Standards Specification: RSS-247 – Digital Transmission Systems (DTSs), Frequency Hopping Systems (FHSs) and Licence-Exempt Local Area Network (LE-LAN) Devices, Issue 1, May 2015
- ❖ ISED Canada Radio Standards Specification: RSS-GEN – General Requirements for Compliance of Radio Apparatus, Issue 4, Nov 2014.

4 LIST OF TEST EQUIPMENT

The calibration interval of test equipment is annually or the manufacturer’s recommendations. Where the calibration interval deviates from the annual cycle based on the instrument manufacturer’s recommendations, it shall be stated below.

Table 4-1: Test Equipment

AssetID	Manufacturer	Model #	Equipment Type	Serial #	Last Calibration Date	Calibration Due Date
1	Rohde & Schwarz	ESMI - Display	Spectrum Analyzers	833771/007	7/11/2014	7/11/2016
2	Rohde & Schwarz	ESMI-Receiver	Spectrum Analyzers	839587/003	7/14/2015	7/14/2016
30	Spectrum Technologies	DRH-0118	Antennas	970102	4/30/2015	4/30/2017
40	EMCO	3104	Antennas	3211	2/10/2015	2/10/2017
73	Agilent	8447D	Amplifiers	2727A05624	7/15/2015	7/15/2016
167	ACS	Cable Set	Cable Set	167	10/20/2015	10/20/2016
267	Agilent	N1911A	Meters	MY45100129	8/24/2015	8/24/2017
268	Agilent	N1921A	Sensors	MY45240184	8/13/2015	8/13/2017
292	Florida RF Cables	SMR-290AW-480.0-SMR	Cables	N/A	2/17/2016	2/17/2017
324	ACS	Belden	Cables	8214	5/2/2016	5/2/2017
334	Rohde&Schwarz	3160-09	Antennas	49404	11/4/2010	NCR
335	Suhner Sucoflex	SF-102A	Cables	882/2A	7/14/2015	7/14/2016
338	Hewlett Packard	8449B	Amplifiers	3008A01111	8/21/2015	8/21/2017
340	Aeroflex/Weinschel	AS-20	Attenuators	7136	7/13/2015	7/13/2016
345	Suhner Sucoflex	102A	Cables	1077/2A	7/14/2015	7/14/2016
412	Electro Metrics	LPA-25	Antennas	1241	7/24/2014	7/24/2016
422	Florida RF	SMS-200AW-72.0-SMR	Cables	805	10/30/2015	10/30/2016
432	Microwave Circuits	H3G020G4	Filters	264066	5/13/2016	5/13/2017
616	Florida RF Cables	SMRE-200W-12.0-SMRE	Cables	N/A	9/3/2015	9/3/2016
622	Rohde & Schwarz	FSV40	Analyzers	101338	7/15/2015	7/15/2016
3010	Rohde & Schwarz	ENV216	LISN	3010	7/10/2015	7/10/2016
RE112	Rohde & Schwarz	ESIB26	Receiver	836119/012	7/16/2015	7/16/2016



5 SUPPORT EQUIPMENT

Table 5-1: Support Equipment

Item	Equipment Type	Manufacturer	Model Number	Serial Number
1	Programming Board	Murata	N/A	N/A
2	Wall Wart Power Supply	Volgen America Inc.	SPU10-105	N/A
3	Evaporating Unit	Mitsubishi Electric Corporation	MSY-GE09NA	3001630

6 EQUIPMENT UNDER TEST SETUP BLOCK DIAGRAM

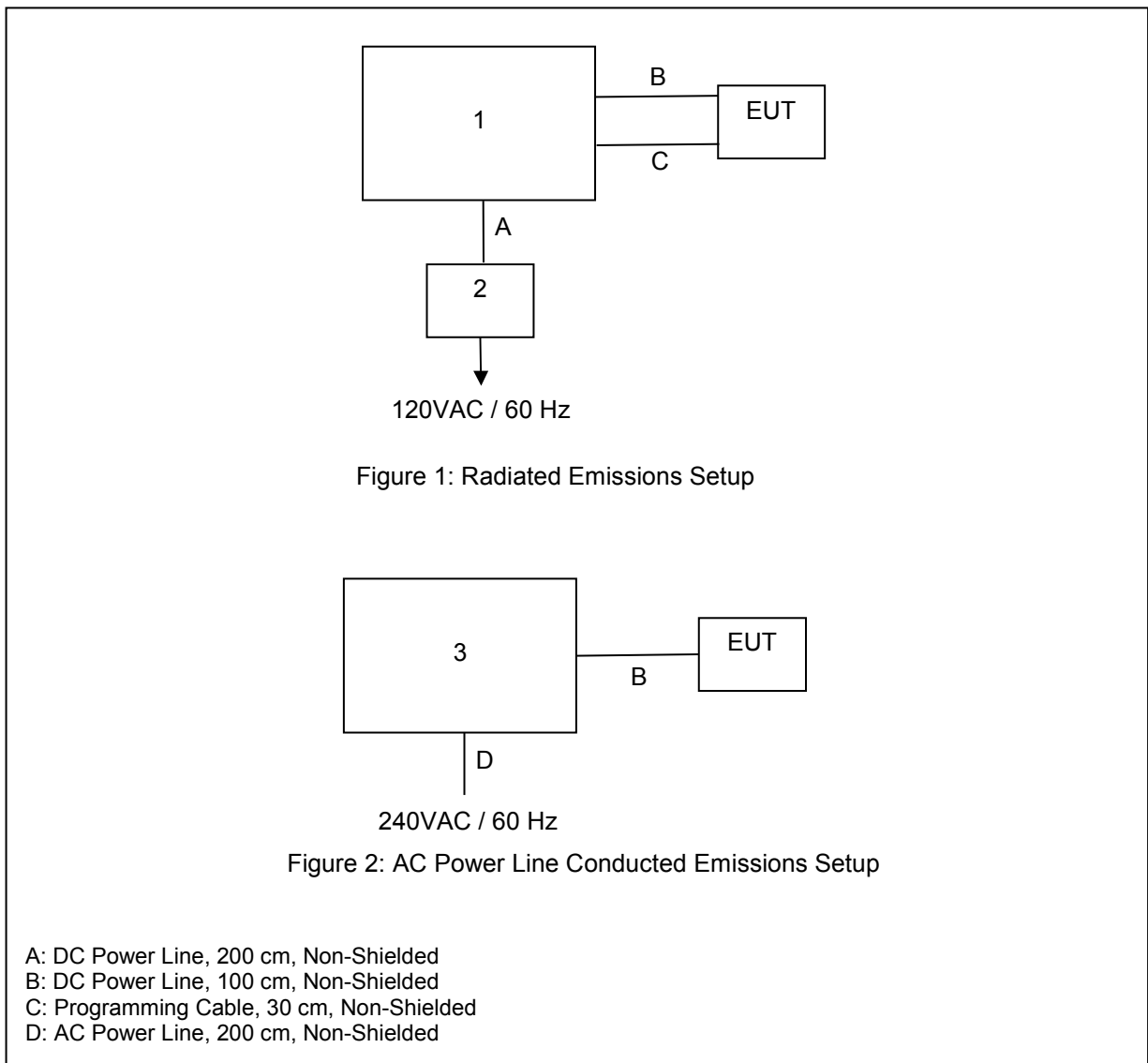

Figure 6-1: Test Setup Block Diagram

## 7 SUMMARY OF TESTS

Along with the tabular data shown below, plots were taken of all signals deemed important enough to document.

### 7.1 Antenna Requirement – FCC 15.203

The EUT utilizes an inverted F antenna. The antenna is integral to the device and cannot be removed or replaced by the end user. The gain of the antenna is 3.3dBi.

### 7.2 Power Line Conducted Emissions – FCC 15.207, ISED Canada: RSS-Gen 8.8

#### 7.2.1 Measurement Procedure

ANSI C63.4 sections 6 and 7 were the guiding documents for this evaluation. Conducted emissions were performed from 150kHz to 30MHz with the spectrum analyzer's resolution bandwidth set to 9kHz and the video bandwidth set to 30kHz. The calculation for the conducted emissions is as follows:

**Corrected Reading = Analyzer Reading + LISN Loss + Cable Loss**

**Margin = Applicable Limit - Corrected Reading**

#### 7.2.2 Measurement Results

**Table 7.2.2-1: Conducted EMI Results Line 1**

Frequency (MHz)	Corrected Reading		Limit (dBuV)	Margin (dB)	Line	Correction (dB)
	Quasi-Peak (dBuV)	Average (dBuV)				
0.190176	---	30.77	53.87	23.10	L1	9.7
0.190176	42.65	---	63.90	21.25	L1	9.7
0.269939	---	32.44	50.87	18.43	L1	9.7
0.269939	40.58	---	60.91	20.33	L1	9.7
0.287275	---	30.19	50.36	20.17	L1	9.7
0.287275	37.08	---	60.40	23.32	L1	9.7
0.391984	---	28.21	47.87	19.66	L1	9.7
0.391984	33.87	---	57.89	24.02	L1	9.7
0.479359	---	21.22	46.32	25.10	L1	9.7
0.479359	27.52	---	56.32	28.80	L1	9.7
18.482866	---	31.55	50.00	18.45	L1	10.3
18.482866	35.32	---	60.00	24.68	L1	10.3

Table 7.2.2-2: Conducted EMI Results Line 2

Frequency (MHz)	Corrected Reading		Limit (dBuV)	Margin (dB)	Line	Correction (dB)
	Quasi-Peak (dBuV)	Average (dBuV)				
0.313127	---	30.16	49.66	19.50	N	9.7
0.313127	39.69	---	59.69	20.00	N	9.7
0.322344	---	37.25	49.42	12.17	N	9.7
0.322344	41.84	---	59.46	17.62	N	9.7
0.383066	---	26.74	48.05	21.31	N	9.7
0.383066	33.30	---	58.07	24.77	N	9.7
1.745190	---	19.04	46.00	26.96	N	9.8
1.745190	26.71	---	56.00	29.29	N	9.8
3.025751	---	18.84	46.00	27.16	N	9.8
3.025751	26.79	---	56.00	29.21	N	9.8
3.470241	---	16.39	46.00	29.61	N	9.8
3.470241	25.47	---	56.00	30.53	N	9.8

7.3 6dB / 99% Bandwidth – FCC 15.247(a)(2), ISED Canada: RSS-247 5.2(1)

7.3.1 Measurement Procedure

The 6dB bandwidth was measured in accordance with the FCC KDB 558074 D01 DTS Meas Guidance v03r05. The Resolution Bandwidth (RBW) of the spectrum analyzer was set to 100 kHz. The Video Bandwidth (VBW) was set to ≥ 3 times the RBW. The trace was set to max hold with a peak detector active. The ndB down function of the spectrum analyzer was utilized to determine the 6 dB bandwidth of the emission.

The occupied bandwidth measurement function of the spectrum analyzer was used to measure the 99% bandwidth. The span of the analyzer was set to capture all products of the modulation process, including the emission sidebands. The resolution bandwidth was set to 1% to 5% of the occupied bandwidth. The video bandwidth was set to 3 times the resolution bandwidth. A peak detector was used.

7.3.2 Measurement Results

Table 7.3.2-1: 6dB / 99% Bandwidth

Frequency [MHz]	6dB Bandwidth [kHz]	99% Bandwidth [kHz]
2402	737.95	1069.34
2440	734.66	1070.44
2480	734.35	1090.75

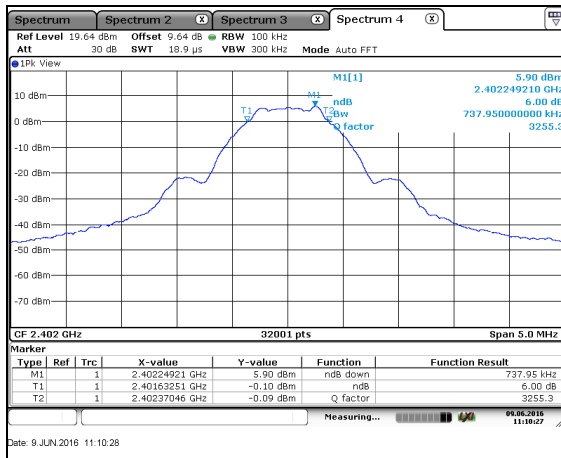

Figure 7.3.2-1: 6dB Bandwidth Plot – LCH

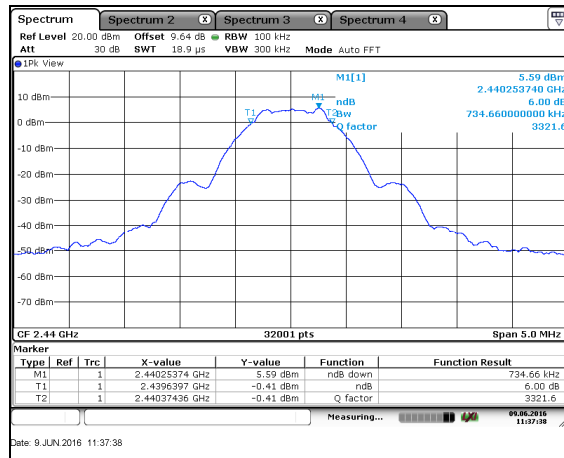

Figure 7.3.2-2: 6dB Bandwidth Plot – MCH

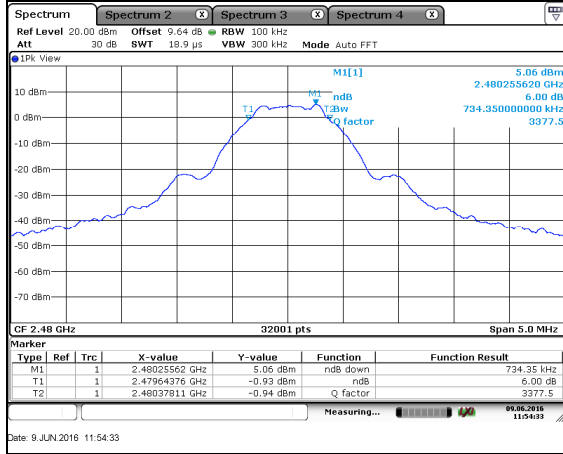

Figure 7.3.2-3: 6dB Bandwidth Plot – HCH



Figure 7.3.2-4: 99% Bandwidth Plot – LCH

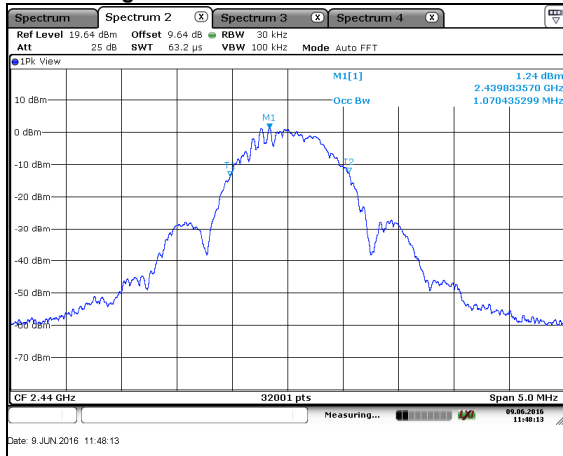

Figure 7.3.2-5: 99% Bandwidth Plot – MCH

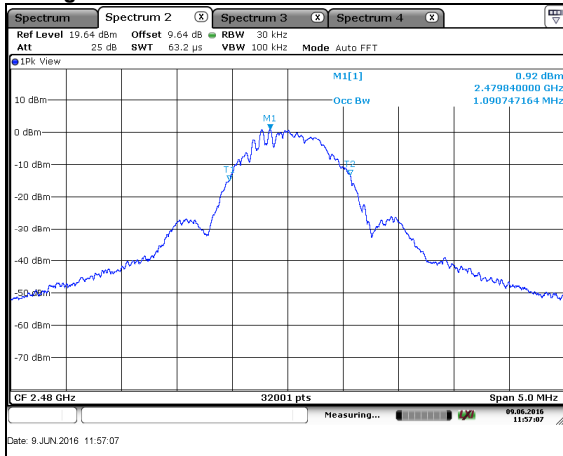

Figure 7.3.2-6: 99% Bandwidth Plot – HCH

**7.4 Fundamental Emission Output Power – FCC 15.247(b)(3), ISED Canada: RSS-247 5.4(4)**

**7.4.1 Measurement Procedure**

The maximum peak conducted output power was measured in accordance with FCC KDB 558074 D01 DTS Meas Guidance v03r05 utilizing the PKPM1 Peak power meter method. The RF output of the equipment under test was directly connected to the input of the power meter applying suitable attenuation. A peak detector was used.

**7.4.2 Measurement Results**

**Table 7.4.2-1: Maximum Peak Conducted Output Power**

<b>Frequency [MHz]</b>	<b>Level [dBm]</b>
2402	6.94
2440	6.85
2480	6.36

7.5 Emission Levels – FCC 15.247(d), 15.205, 15.209; ISED Canada: RSS-247 5.5, RSS-Gen 8.9/8.10

7.5.1 Emissions into Non-restricted Frequency Bands

7.5.1.1 Measurement Procedure

The unwanted emissions into non-restricted bands were measured conducted in accordance with FCC KDB 558074 D01 DTS Meas Guidance v03r05. The RF output of the equipment under test was directly connected to the input of the spectrum analyzer applying suitable attenuation. The Resolution Bandwidth (RBW) of the spectrum analyzer was set to 100 kHz. The Video Bandwidth (VBW) was set to ≥ 300 kHz. Span was set to 1.5 times the DTS bandwidth. The trace was set to max hold with a peak detector active. The resulting spectrum analyzer peak level was used to determine the reference level with respect to the 20 dBc limit. The spectrum span was then adjusted for the measurement of spurious emissions from 30MHz to 25GHz, 10 times the highest fundamental frequency.

Band-edge compliance was determined using the conducted marker-delta method in which the radio frequency power that is produced by the EUT is at least 20 dB below that in the 100 kHz bandwidth within the band that contains the highest level of desired power.

7.5.1.2 Measurement Results

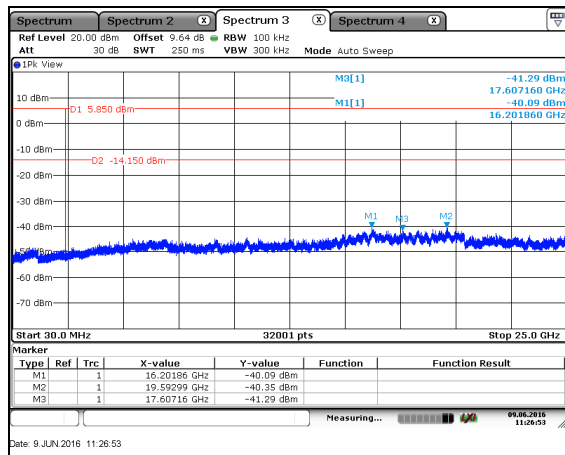

Figure 7.5.1.2-1: 30 MHz – 25 GHz – LCH

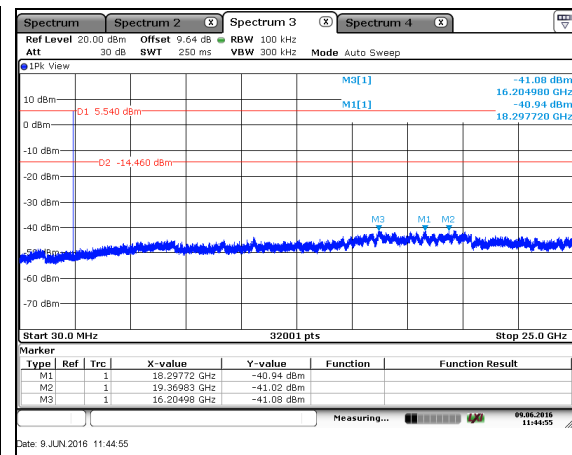

Figure 7.5.1.2-2: 30 MHz – 25 GHz – MCH

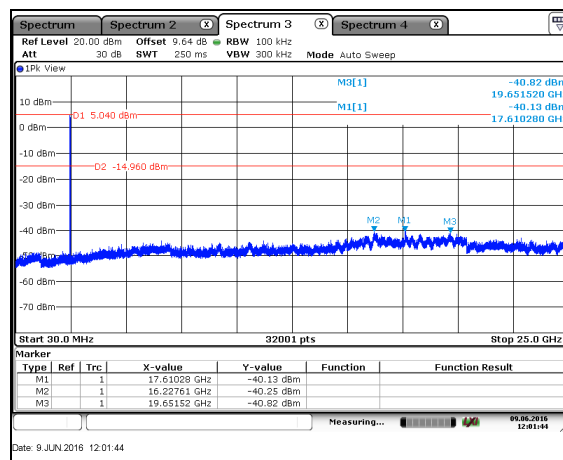

Figure 7.5.1.2-3: 30 MHz – 25 GHz – HCH

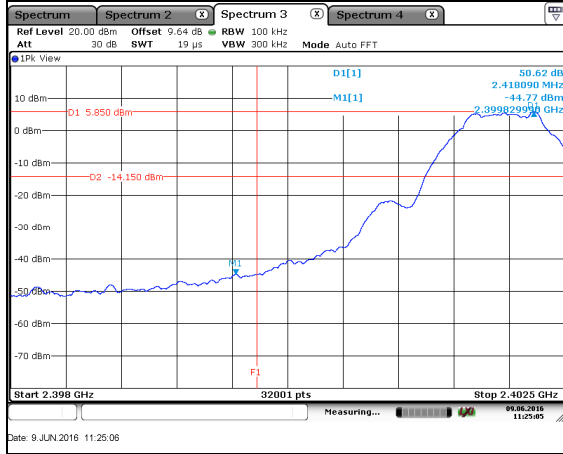

Figure 7.5.1.2-4: Lower Band-edge - LCH

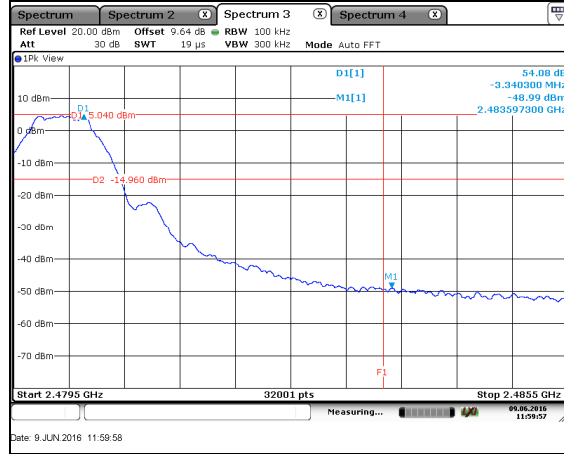

Figure 7.5.1.2-5: Upper Band-edge - HCH



**7.5.2 Emissions into Restricted Frequency Bands**

**7.5.2.1 Measurement Procedure**

The unwanted emissions into restricted bands were measured radiated over the frequency range of 30MHz to 25GHz, 10 times the highest fundamental frequency.

The EUT was rotated through 360° and the receive antenna height was varied from 1m to 4m so that the maximum radiated emissions level would be detected. For frequencies below 1000MHz, quasi-peak measurements were made using a RBW of 120 kHz and a VBW of 300 kHz. For frequencies above 1000MHz, peak and average measurements were made with RBW and VBW of 1 MHz and 3 MHz respectively.

Each emission found to be in a restricted band as defined by section 15.205, including any emission at the operational band-edge, was compared to the radiated emission limits as defined in section 15.209.

**7.5.2.2 Duty Cycle Correction**

For average radiated measurements, using a 4.69% duty cycle, the measured level was reduced by a factor 26.58dB. The duty cycle correction factor is determined using the formula: 20log (4.69/100).

A detail explanation of the duty cycle is provided in the theory of operation accompanying this report.

**7.5.2.3 Measurement Results**

**Table 7.5.2.3-1: Radiated Spurious Emissions Tabulated Data**

Frequency (MHz)	Level (dBuV)		Antenna Polarity (H/V)	Correction Factors (dB)	Corrected Level (dBuV/m)		Limit (dBuV/m)		Margin (dB)	
	pk	Qpk/Avg			pk	Qpk/Avg	pk	Qpk/Avg	pk	Qpk/Avg
<b>Low Channel</b>										
All emissions were attenuated below the noise floor of the instrumentation										
<b>Middle Channel</b>										
4880	56.21	51.81	H	2.26	58.47	27.49	74.0	54.0	15.5	26.5
4880	56.51	52.04	V	2.26	58.77	27.72	74.0	54.0	15.2	26.3
7320	46.23	35.28	H	8.02	54.25	16.72	74.0	54.0	19.8	37.3
7320	46.75	35.66	V	8.02	54.77	17.10	74.0	54.0	19.2	36.9
<b>High Channel</b>										
2483.5	60.05	47.32	H	-4.93	55.12	15.82	74.0	54.0	18.9	38.2
2483.5	54.01	42.34	V	-4.93	49.08	10.84	74.0	54.0	24.9	43.2
4960	56.13	51.38	H	2.51	58.64	27.31	74.0	54.0	15.4	26.7
4960	59.05	52.98	V	2.51	61.56	28.91	74.0	54.0	12.4	25.1
7440	48.03	36.78	H	8.10	56.13	18.30	74.0	54.0	17.9	35.7
7440	49.05	38.74	V	8.10	57.15	20.26	74.0	54.0	16.9	33.7

**7.5.2.4 Sample Calculation:**

$$R_C = R_U + CF_T$$

Where:

$CF_T$	=	Total Correction Factor (AF+CA+AG)-DC (Average Measurements Only)
$R_U$	=	Uncorrected Reading
$R_C$	=	Corrected Level
AF	=	Antenna Factor
CA	=	Cable Attenuation
AG	=	Amplifier Gain
DC	=	Duty Cycle Correction Factor

**Example Calculation: Peak**Corrected Level:  $56.21 + 2.26 = 58.47\text{dBuV/m}$ Margin:  $74.0\text{dBuV/m} - 58.47\text{dBuV/m} = 15.5\text{dB}$ **Example Calculation: Average**Corrected Level:  $51.81 + 2.26 - 26.58 = 27.49\text{dBuV}$ Margin:  $54.0\text{dBuV} - 27.49\text{dBuV} = 26.5\text{dB}$

**7.6 Maximum Power Spectral Density in the Fundamental Emission – FCC 15.247(e)  
ISED Canada: RSS-247 5.2(2)**

**7.6.1 Measurement Procedure**

The power spectral density was measured in accordance with the FCC KDB 558074 D01 DTS Meas Guidance v03r05 utilizing the PKPSD (peak PSD) method. The RF output of the equipment under test was directly connected to the input of the spectrum analyzer applying suitable attenuation. The Resolution Bandwidth (RBW) of the spectrum analyzer was set to 3 kHz. The Video Bandwidth (VBW) was set to 10 kHz. Span was set to 1.5 times the occupied bandwidth. The trace was set to max hold with a peak detector active.

**7.6.2 Measurement Results**

**Table 7.6.2-1: Peak Power Spectral Density**

Frequency (MHz)	PSD Level (dBm)
2402	-10.39
2440	-10.83
2480	-11.38

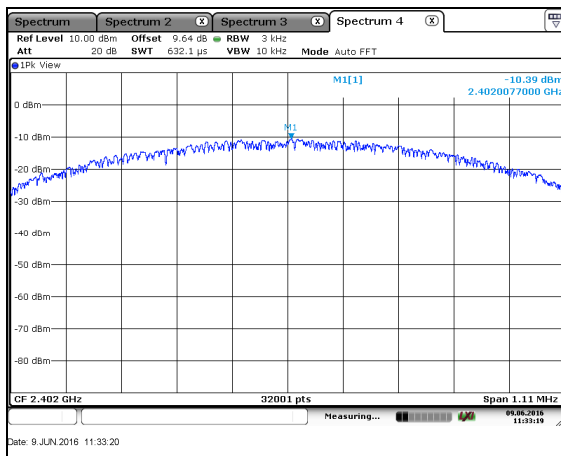

**Figure 7.6.2-1: PSD Plot – LCH**

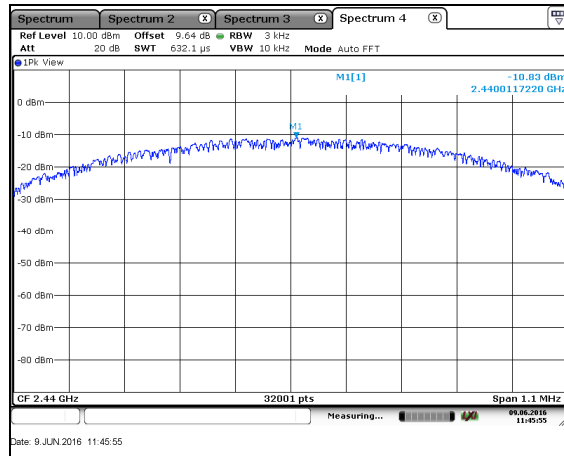

**Figure 7.6.2-2: PSD Plot – MCH**

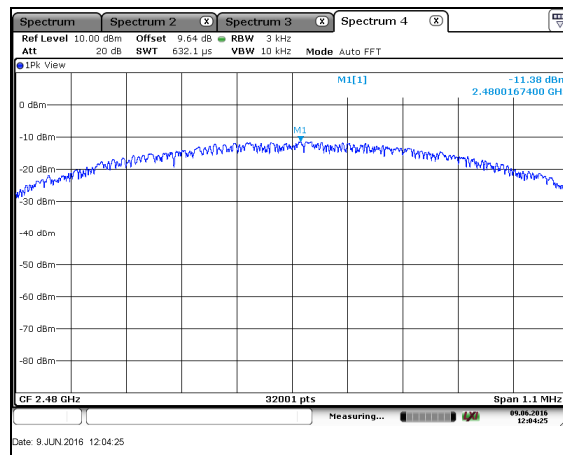

**Figure 7.6.2-3: PSD Plot – HCH**

**8 CONCLUSION**

In the opinion of ACS, Inc. the PAC-USWHS002-WF-1, manufactured by Mitsubishi Electric US, Inc. meets the requirements of FCC Part 15 subpart C and ISED Canada's Radio Standards Specification RSS-247.

**END REPORT**