

TEST REPORT

FCC ID: 2AIFYSD55

Product: MOBILE PHONE

Model No.: SD55

Additional Model No.: N/A

Trade Mark: UNEONE

Report No.: TCT171110E029

Issued Date: Nov. 15, 2017

Issued for:

Darmuoba, S.A. de C.V

**Mar Negro 1, Col. Tacuba, CDMX. C.P 11410 Miguel Hidalgo, Distrito Federal,
Mexico**

Issued By:

Shenzhen Tongce Testing Lab.

**1B/F., Building 1, Yibaolai Industrial Park, Qiaotou, Fuyong, Baoan District,
Shenzhen, Guangdong, China**

TEL: +86-755-27673339

FAX: +86-755-27673332

Note: *This report shall not be reproduced except in full, without the written approval of Shenzhen Tongce Testing Lab.*

This document may be altered or revised by Shenzhen Tongce Testing Lab. personnel only, and shall be noted in the revision section of the document. The test results in the report only apply to the tested sample.

TABLE OF CONTENTS

1. Test Certification	3
2. Test Result Summary	4
3. EUT Description.....	5
4. Genera Information.....	6
4.1. Test environment and mode.....	6
4.2. Test Mode.....	8
4.3. Description of Support Units.....	9
4.4. Configuration of Tested System	10
4.5. Measurement Results Explanation Example.....	10
5. Facilities and Accreditations	11
5.1. Facilities	11
5.2. Location	11
5.3. Measurement Uncertainty.....	11
6. Test Results and Measurement Data	12
6.1. Conducted Output Power Measurement	12
6.2. Peak to Average Ratio.....	14
6.3. 99% Occupied Bandwidth and 26dB Bandwidth Measurement	16
6.4. Band Edge and Conducted Spurious Emission Measurement	25
6.5. Effective Radiated Power and Effective Isotropic Radiated Power Measurement	36
6.6. Field Strength of Spurious Radiation Measurement	46
6.7. Frequency Stability Measurement	53

Appendix A: Photographs of Test Setup

Appendix B: Photographs of EUT

1. Test Certification

Product:	MOBILE PHONE
Model No.:	SD55
Additional Model No.:	N/A
Trade Mark:	UNEONE
Applicant:	Darmuoba, S.A. de C.V
Address:	Mar Negro 1, Col. Tacuba, CDMX. C.P 11410 Miguel Hidalgo, Distrito Federal, Mexico
Manufacturer:	Z-TECH COMMUNICATION(SZ)CO., LTD
Address:	7/F BLK D BAO'AN ZHI'GU YIN'TIAN RD. NO.4 XI'XIANG ST' BAO'AN Shenzhen China
Date of Test:	Oct. 19 - 25, 2017
Applicable Standards:	FCC CFR Title 47 Part 2: 2017 FCC CFR Title 47 Part22 Subpart H: 2017 FCC CFR Title 47 Part24 Subpart E: 2017

The above equipment has been tested by Shenzhen Tongce Testing Lab. and found compliance with the requirements set forth in the technical standards mentioned above. The results of testing in this report apply only to the product/system, which was tested. Other similar equipment will not necessarily produce the same results due to production tolerance and measurement uncertainties.

Tested By:

Brews Xu

Date:

Oct. 19, 2017

Brews Xu

Reviewed By:

Joe Zhou

Date:

Nov. 15, 2017

Joe Zhou

Approved By:

Tomsin

Date:

Nov. 15, 2017

Tomsin

2. Test Result Summary

Requirement	CFR 47 Section	Result
Conducted Output Power	§22.913; §2.1046 §24.232;	PASS
Peak-to-Average Ratio	§2.1046; §24.232(d)	PASS
Effective Radiated Power	§2.1046; §22.913(a) §24.232;	PASS
Equivalent Isotropic Radiated Power	§2.1046; §22.913(a) §24.232;	PASS
Occupied Bandwidth	§2.1049	PASS
Band Edge	§2.1051 §22.917(a) §24.238(a)	PASS
Conducted Spurious Emission	§2.1051; §22.917 §24.238;	PASS
Field Strength of Spurious Radiation	§2.1053; §22.917(a) §24.238;	PASS
Frequency Stability for Temperature & Voltage	§2.1055; §22.355 §24.235;	PASS

Note:

1. PASS: Test item meets the requirement.
2. Fail: Test item does not meet the requirement.
3. N/A: Test case does not apply to the test object.
4. The test result judgment is decided by the limit of test standard.

3. EUT Description

Product:	MOBILE PHONE
Model No.:	SD55
Additional Model No.:	N/A
Trade Mark:	UNEONE
3G Version:	WCDMA:R99 HSDPA: Release 5 HSUPA: Release 6
Tx Frequency:	GSM/GPRS/EGPRS 850: 824.2 MHz ~ 848.8 MHz GSM/GPRS 1900: 1850.2 MHz ~ 1909.8MHz WCDMA Band V: 826.4 MHz ~ 846.6 MHz WCDMA Band II: 1852.4 MHz ~ 1907.6 MHz
Rx Frequency:	GSM/GPRS/EGPRS 850: 869.2 MHz ~ 893.8 MHz GSM/GPRS 1900: 1930.2 MHz ~ 1989.8 MHz WCDMA Band V: 871.4 MHz ~ 891.6 MHz WCDMA Band II: 1932.4 MHz ~ 1987.6 MHz
Maximum Output Power to Antenna:	GSM850: 33.80dBm GSM1900: 28.64dBm GPRS 850: 33.81dBm GPRS 1900: 21.02dBm EGPRS850: 23.85dBm WCDMA Band V: 22.50dBm WCDMA Band II: 22.26dBm
99% Occupied Bandwidth:	GSM850: 247KGXM GSM1900: 246KGXM GPRS850: 247KGXW GPRS1900: 246KGXW EGPRS850 : 241KG7W WCDMA Band V RMC 12.2Kbps: 4M16F9W WCDMA Band II RMC 12.2Kbps: 4M15F9W
Type of Modulation:	GSM/GPRS: GMSK EGPRS: 8PSK WCDMA/HSDPA/HSUPA: QPSK
Antenna Type:	MONOPOLE antenna
Antenna Gain:	GSM/GPRS/EGPRS 850: -4.1dBi GSM/GPRS 1900: 1.2dBi WCDMA Band V : -4.1dBi WCDMA Band II : 1.2dBi
Power Supply:	Adaptador ca/cc Entrada: AC 100-240V Salida: DC 5.0V, 1A Or C 3.8V 2500mAh Ion de Litio

4. Genera Information

4.1. Test environment and mode

Operating Environment:	
Temperature:	25.0 °C
Humidity:	56 % RH
Atmospheric Pressure:	1010 mbar
Test Mode:	
Operation mode:	Keep the EUT in communication with CMU200 and select channel with modulation
Remark: This product has a built-in rechargeable battery, so in an independent test, the EUT battery was fully-charged.	
The sample was placed (0.8m below 1GHz, 0.8m above 1GHz) above the ground plane of 3m chamber. Measurements in both horizontal and vertical polarities were performed. During the test, each emission was maximized by: having the EUT continuously working, investigated all operating modes, rotated about all 3 axis (X, Y & Z) and considered typical configuration to obtain worst position, manipulating interconnecting cables, rotating the turntable, varying antenna height from 1m to 4m in both horizontal and vertical polarizations. The emissions worst-case are shown in Test Results of the following pages.	

Description Operation Frequency

GSM 850		PCS1900	
Channel:	Frequency (MHz)	Channel:	Frequency (MHz)
128	824.20	512	1850.20
129	824.40	513	1850.40
....
189	836.40	660	1879.80
190	836.60	661	1880.00
191	836.80	662	1880.20
...
250	848.60	809	1909.60
251	848.80	810	1909.80

WCDMA Band V		WCDMA Band II	
Channel:	Frequency (MHz)	Channel:	Frequency (MHz)
4132	826.40	9262	1852.40
4133	826.60	9263	1852.60
....
4182	836.40	9399	1879.80
4183	836.60	9400	1880.00
4184	836.80	9401	1880.20
...
4233	846.60	9538	1907.60

Final test channel:

GSM 850		PCS1900		WCDMA Band V		WCDMA Band II	
Channel	Frequency (MHz)	Channel	Frequency (MHz)	Channel	Frequency (MHz)	Channel	Frequency (MHz)
128	824.20	512	1850.20	4132	826.40	9262	1852.40
190	836.60	661	1880.00	4183	836.60	9400	1880.00
251	848.80	810	1909.80	4233	846.60	9538	1907.60

4.2. Test Mode

Antenna port conducted and radiated test items were performed according to KDB 971168 D01 Power Meas. License Digital Systems v02r02 with maximum output power. Radiated measurements were performed with rotating EUT in different three orthogonal test planes to find the maximum emission.

Radiated emissions were investigated as following frequency range:

1. 30 MHz to 10000 MHz for GSM850 and WCDMA Band V.
2. 30 MHz to 20000 MHz for PCS1900, WCDMA Band II and WCDMA Band IV.

All modes and data rates and positions were investigated.

Test modes are chosen to be reported as the worst case configuration below:

Test Mode		
Band	Radiated TCs	Conducted TCs
GSM 850	GSM Link GPRS class 12 Link EGPRS class 12 Link	GSM Link GPRS class 12 Link EGPRS class 12 Link
PCS 1900	GSM Link GPRS class 12 Link	GSM Link GPRS class 12 Link
WCDMA Band V	RMC 12.2Kbps Link	RMC 12.2Kbps Link
WCDM Band II	RMC 12.2Kbps Link	RMC 12.2Kbps Link

Note: The maximum power levels are chosen to test as the worst case configuration as follows:

GPRS multi-slot class 12 mode for GMSK modulation, EDGE multi-slot class 10 mode for 8PSK modulation. RMC 12.2Kbps mode for WCDMA band V and WCDMA band II, only these modes were used for all tests. In addition to above worst-case test, below investigating on all data rates and all modes are compliance with each FCC test case which has specific test limits. For spurious emissions at antenna port, the EUT was investigated the band edges on low and high channels, and the unwanted spurious emissions on middle channel for all modes, the results are PASS, then only the worst-results were reported in the test report. The Radiated Spurious emissions for GPRS and EDGE modes were investigated on the middle channel and the PASS results were not worst than those data tested from the highest power channels.

4.3. Description of Support Units

The EUT has been tested as an independent unit together with other necessary accessories or support units. The following support units or accessories were used to form a representative test configuration during the tests.

Equipment	Model No.	Serial No.	FCC ID	Trade Name
/	/	/	/	/

Note:

1. All the equipment/cables were placed in the worst-case configuration to maximize the emission during the test.
2. Grounding was established in accordance with the manufacturer's requirements and conditions for the intended use.

4.4. Configuration of Tested System

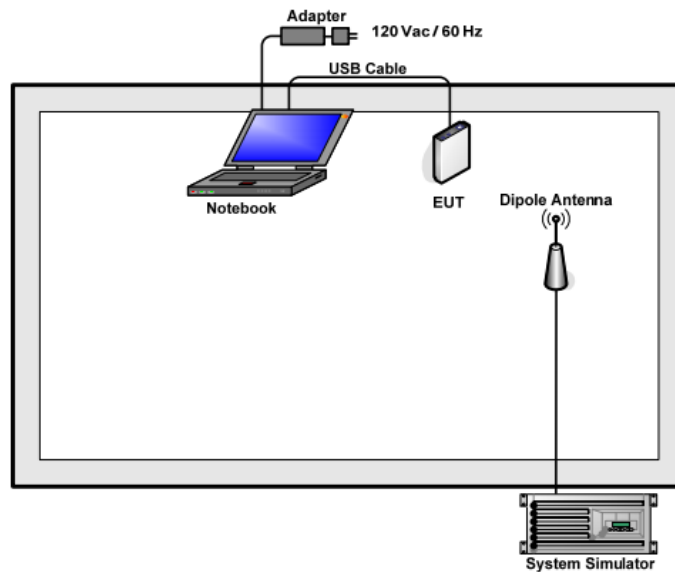

4.5. Measurement Results Explanation Example

For all conducted test items:

The offset level is set in the spectrum analyzer to compensate the RF cable loss and attenuator factor between RF conducted output port and spectrum analyzer. With the offset compensation, the spectrum analyzer reading level will be exactly the RF output level. The spectrum analyzer offset is derived from RF cable loss and attenuator factor.
 $Offset = RF\ cable\ loss + attenuator\ factor.$

The following shows an offset computation example with RF cable loss 3 dB and a 5dB attenuator.

Example: $Offset\ (dB) = RF\ cable\ loss\ (dB) + attenuator\ factor\ (dB).$
 $= 8(dB)$

5. Facilities and Accreditations

5.1. Facilities

The test facility is recognized, certified, or accredited by the following organizations:

- FCC - Registration No.: 645098

Shenzhen Tongce Testing Lab

The 3m Semi-anechoic chamber has been registered and fully described in a report with the (FCC) Federal Communications Commission. The acceptance letter from the FCC is maintained in our files.

- IC - Registration No.: 10668A-1

The 3m Semi-anechoic chamber of Shenzhen TCT Testing Technology Co., Ltd. has been registered by Certification and Engineering Bureau of Industry Canada for radio equipment testing

5.2. Location

Shenzhen Tongce Testing Lab

Address: 1B/F., Building 1, Yibaolai Industrial Park, Qiaotou, Fuyong, Baoan District, Shenzhen, Guangdong, China

TEL: +86-755-27673339

5.3. Measurement Uncertainty

The reported uncertainty of measurement $y \pm U$, where expanded uncertainty U is based on a standard uncertainty multiplied by a coverage factor of $k=2$, providing a level of confidence of approximately 95 %.

No.	Item	MU
1	Conducted Emission	$\pm 2.56\text{dB}$
2	RF power, conducted	$\pm 0.12\text{dB}$
3	Spurious emissions, conducted	$\pm 0.11\text{dB}$
4	All emissions, radiated(<1G)	$\pm 3.92\text{dB}$
5	All emissions, radiated(>1G)	$\pm 4.28\text{dB}$
6	Temperature	$\pm 0.1^\circ\text{C}$
7	Humidity	$\pm 1.0\%$

6. Test Results and Measurement Data

6.1. Conducted Output Power Measurement

6.1.1. Test Specification

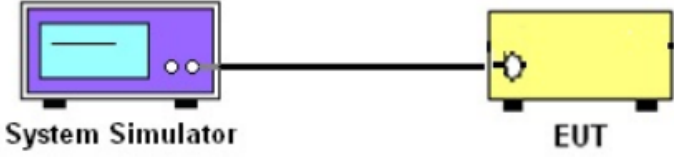
Test Requirement:	FCC part 22.913(a) and FCC part 24.232(b) FCC part 27.50(d);
Test Method:	FCC part 2.1046
Operation mode:	Refer to item 4.1
Limits:	GSM 850 7W PCS 1900 2W WCDMA Band V:7W WCDMA Band II: 2W
Test Setup:	 <p>The diagram illustrates the test setup. On the left is a purple box labeled 'System Simulator' with a screen and two buttons. A black cable connects it to a yellow box on the right labeled 'EUT' (Equipment Under Test).</p>
Test Procedure:	<ol style="list-style-type: none"> 1. The transmitter output port was connected to the system simulator. 2. Set EUT at maximum power through system simulator. 3. Select lowest, middle, and highest channels for each band and different modulation. 4. Measure the maximum burst average power for GSM and maximum average power for other modulation signal.
Test Result:	PASS

6.1.2. Test Instruments

Equipment	Manufacturer	Model	Serial Number	Calibration Due
System simulator	R&S	CMU200	111382	Sep. 27, 2018
RF cable (9kHz-40GHz)	TCT	RE-05	N/A	Sep. 27, 2018
Antenna Connector	TCT	RFC-02	N/A	Sep. 27, 2018

Note: The calibration interval of the above test instruments is 12 months and the calibrations are traceable to international system unit (SI)

6.1.3. Test data

Conducted Power Measurement Results:

Average Conducted Power (*Unit: dBm)						
Band	GSM850			PCS1900		
Channel	128	190	251	512	661	810
Frequency	824.20	836.60	848.80	1850.20	1880.00	1909.80
GSM (GMSK, 1 TX slot)	33.64	33.76	33.80	28.64	28.32	28.39
GPRS (GMSK, 1 TX slot)	33.65	33.77	33.81	20.41	20.32	21.02
GPRS (GMSK, 2 TX slot)	32.74	32.90	32.98	20.27	20.12	20.89
GPRS (GMSK, 3 TX slot)	30.71	30.91	31.04	20.04	20.02	20.72
GPRS (GMSK, 4 TX slot)	29.32	29.56	29.84	19.91	19.84	20.61
EGPRS (8PSK, 1 TX slot)	23.54	23.74	23.85	/	/	/
EGPRS (8PSK, 2 TX slot)	21.93	22.26	22.38	/	/	/
EGPRS (8PSK, 3 TX slot)	19.95	19.85	19.67	/	/	/
EGPRS (8PSK, 4 TX slot)	18.21	18.50	18.61	/	/	/

Average Conducted Power (*Unit: dBm)						
Band	WCDMA Band II			WCDMA Band V		
Channel	9262	9400	9538	4132	4183	4233
Frequency	1852.4	1880.0	1907.6	826.4	836.6	846.6
RMC 12.2Kbps	22.05	22.34	22.01	22.26	22.26	22.20
HSDPA Subtest-1	21.35	21.54	21.22	22.21	22.16	22.15
HSDPA Subtest-2	21.34	21.46	21.26	22.19	22.13	22.14
HSDPA Subtest-3	21.25	21.47	21.14	22.15	22.11	22.07
HSDPA Subtest-4	21.30	21.58	21.21	22.21	22.13	22.13
HSUPA Subtest-1	21.30	21.57	21.27	22.18	22.14	22.14
HSUPA Subtest-2	21.29	21.37	21.18	22.18	22.10	22.16
HSUPA Subtest-3	21.23	21.45	21.17	22.13	22.04	22.09
HSUPA Subtest-4	21.30	21.56	21.16	22.20	22.17	22.17
HSUPA Subtest-5	21.31	21.42	21.19	22.19	22.13	22.10
AMR	22.37	22.50	22.16	22.20	22.22	22.14

6.2. Peak to Average Ratio

6.2.1. Test Specification

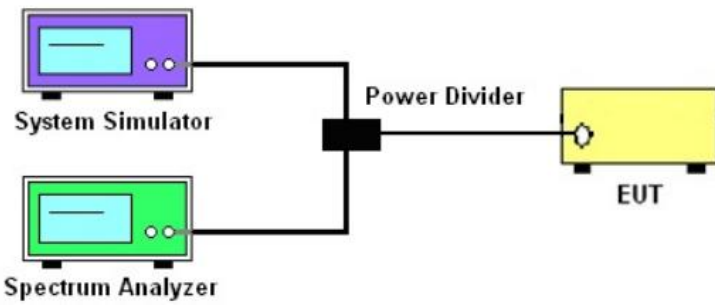
Test Requirement:	FCC part 24.232(d) ; FCC part 22.913; FCC part 27.50(d);
Test Method:	FCC KDB 971168 v02r02 Section 5.7.1
Operation mode:	Refer to item 4.1
Limit:	The peak-to-average ratio (PAR) of the transmission may not exceed 13 dB.
Test Setup:	 <p>The diagram illustrates the test setup. On the left, there are two computer monitors: a purple one labeled 'System Simulator' and a green one labeled 'Spectrum Analyzer'. Both are connected to a central black box labeled 'Power Divider'. From the 'Power Divider', a single line connects to a yellow rectangular device on the right labeled 'EUT' (Equipment Under Test).</p>
Test Procedure:	<ol style="list-style-type: none"> 1. The testing follows FCC KDB 971168 v02r02 Section 5.7.1. 2. The EUT was connected to spectrum analyzer and system simulator via a power divider. 3. Set EUT to transmit at maximum output power. 4. For GSM/EGPRS operating modes, signal gating is implemented on the spectrum analyzer by triggering from the system simulator. 5. Set the CCDF (Complementary Cumulative Distribution Function) option of the spectrum analyzer. Record the maximum PAPR level associated with a probability of 0.1%.
Test Result:	PASS

6.2.2. Test Instruments

Equipment	Manufacturer	Model	Serial Number	Calibration Due
System simulator	R&S	CMU200	111382	Sep. 27, 2018
Spectrum Analyzer	Agilent	N9020A	MY49100060	Sep. 27, 2018
RF cable (9kHz-40GHz)	TCT	RE-05	N/A	Sep. 27, 2018
Antenna Connector	TCT	RFC-02	N/A	Sep. 27, 2018

Note: The calibration interval of the above test instruments is 12 months and the calibrations are traceable to international system unit (SI).

6.2.3. Test Data

Test mode	Peak to Average Ratio (dB)			Limit (dB)	Result
	Low Ch.	Middle Ch.	High Ch.		
WCDMA Band II	2.43	2.52	2.99	13	PASS
WCDMA Band V	2.57	2.66	2.69		

6.3. 99% Occupied Bandwidth and 26dB Bandwidth Measurement

6.3.1. Test Specification

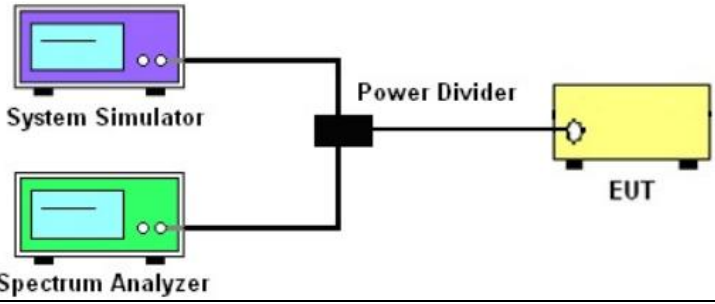
Test Requirement:	FCC part 2.1049
Test Method:	FCC part 2.1049
Operation mode:	Refer to item 4.1
Limit:	N/A
Test Setup:	 <p>The diagram illustrates the test setup. On the left, there are two instruments: a System Simulator (top, purple) and a Spectrum Analyzer (bottom, green). Both are connected to a central Power Divider (black). The Power Divider is then connected to the EUT (Equipment Under Test, yellow) on the right.</p>
Test Procedure:	<ol style="list-style-type: none"> 1. The testing follows FCC KDB 971168 v02r02 Section 4.2. 2. The EUT was connected to the spectrum analyzer and system simulator via a power divider. 3. The RF output of the EUT was connected to the spectrum analyzer by RF cable and attenuator. The path loss was compensated to the results for each measurement. 4. The 99% occupied bandwidth were measured, set RBW= 1% of span, VBW= 3*RBW, sample detector, trace maximum hold. 5. The 26dB bandwidth were measured, set RBW= 1% of EBW, VBW= 3*RBW, peak detector, trace maximum hold.
Test Result:	PASS

6.3.2. Test Instruments

Equipment	Manufacturer	Model	Serial Number	Calibration Due
System simulator	R&S	CMU200	111382	Sep. 27, 2018
Spectrum Analyzer	Agilent	N9020A	MY49100060	Sep. 27, 2018
RF cable (9kHz-40GHz)	TCT	RE-05	N/A	Sep. 27, 2018
Antenna Connector	TCT	RFC-02	N/A	Sep. 27, 2018

Note: The calibration interval of the above test instruments is 12 months and the calibrations are traceable to international system unit (SI).

6.3.3. Test Data

EUT Mode	Channel	Frequency (MHz)	99% Occupy bandwidth (KHz)	-26dB bandwidth (KHz)
GSM 850 (GSM link)	128	824.20	246.55	320.40
	190	836.60	246.16	316.60
	251	848.80	244.70	318.70
GSM 850 (GPRS 1 link)	128	824.20	245.59	312.90
	190	836.60	240.80	310.10
	251	848.80	246.85	317.70
GSM 850 (EGPRS 1 link)	128	824.20	229.26	306.00
	190	836.60	239.86	282.80
	251	848.80	241.33	325.40
PCS 1900 (GSM link)	512	1850.20	245.89	307.10
	661	1880.00	242.03	318.60
	810	1909.80	243.58	319.70
PCS 1900 (GPRS 1 link)	512	1850.20	246.26	317.50
	661	1880.00	243.07	319.70
	810	1909.80	246.25	313.90
WCDMA Band V (RMC 12.2Kbps link)	4132	826.40	4137.10	4667.00
	4183	836.60	4151.50	4666.00
	4233	846.60	4136.60	4692.00
WCDMA Band II (RMC 12.2Kbps link)	9262	1852.4	4158.60	4683.00
	9400	1880.0	4152.20	4690.00
	9538	1907.6	4162.40	4671.00

Test plots as follows:

Test band:

GSM 850 (GSM link)

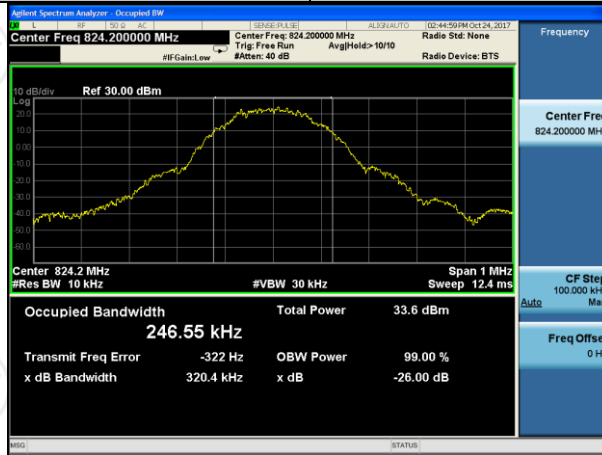

Lowest channel



Middle channel



Highest channel

Test band:

GSM 850 (GPRS 1 link)

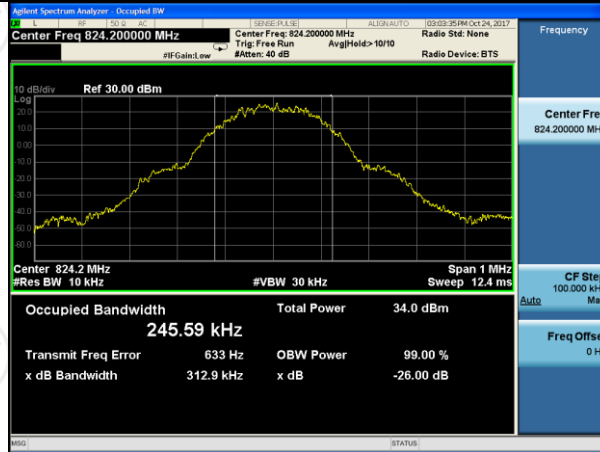

Lowest channel



Middle channel

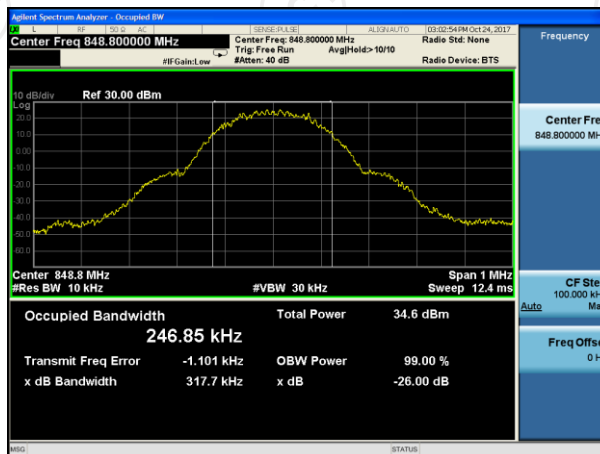

Highest channel

Test band:

GSM 850 (EGPRS 1 link)

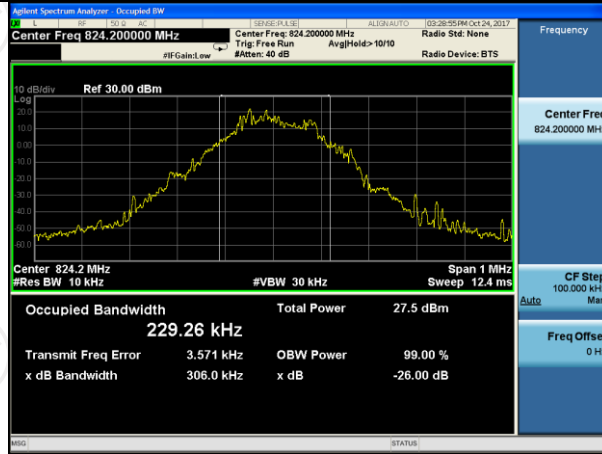

Lowest channel

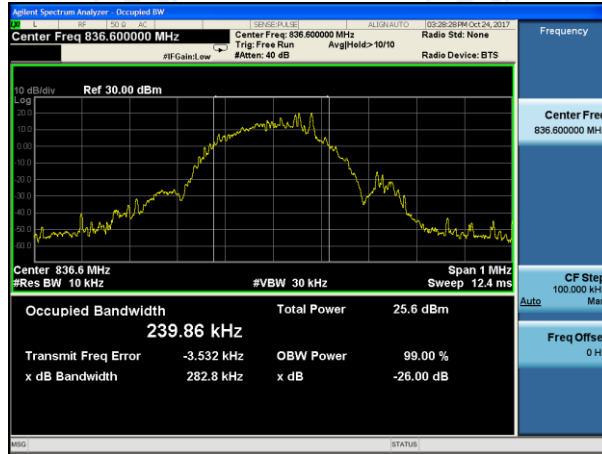

Middle channel

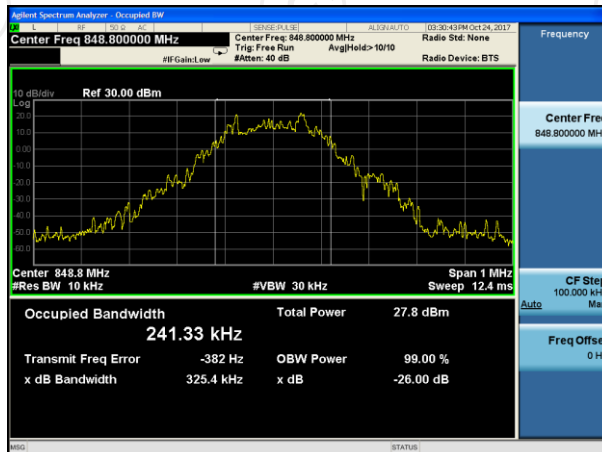

Highest channel

Test band:

PCS 1900 (GSM link)

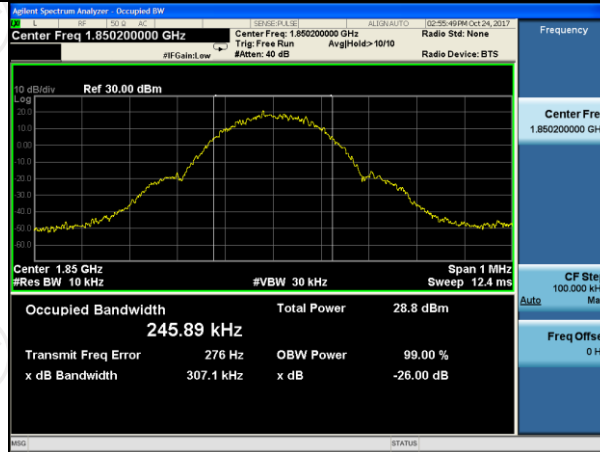

Lowest channel

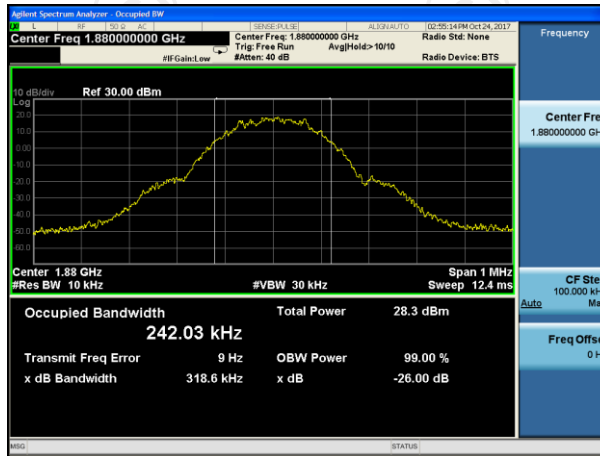

Middle channel

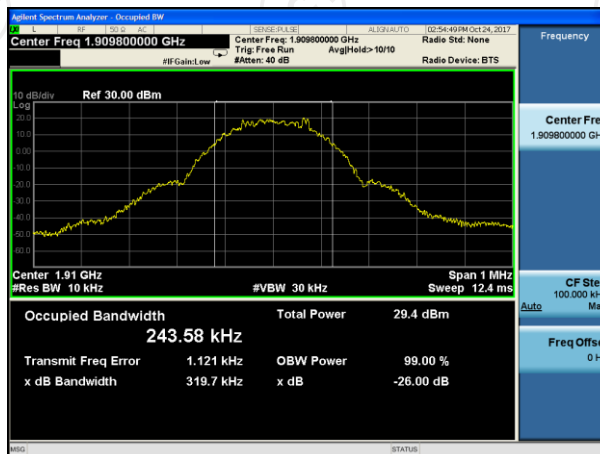

Highest channel

Test band:

PCS 1900 (GPRS 1 link)

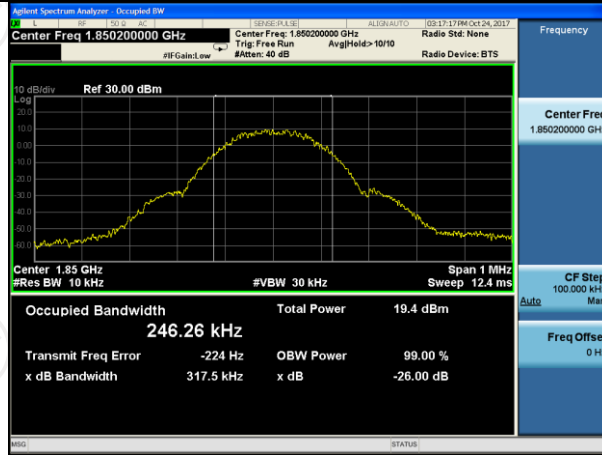

Lowest channel

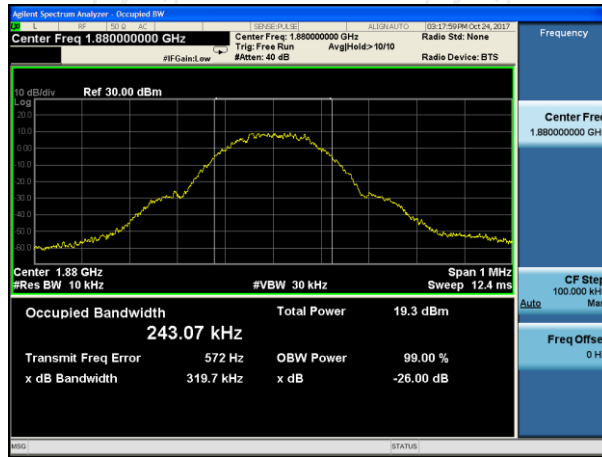

Middle channel

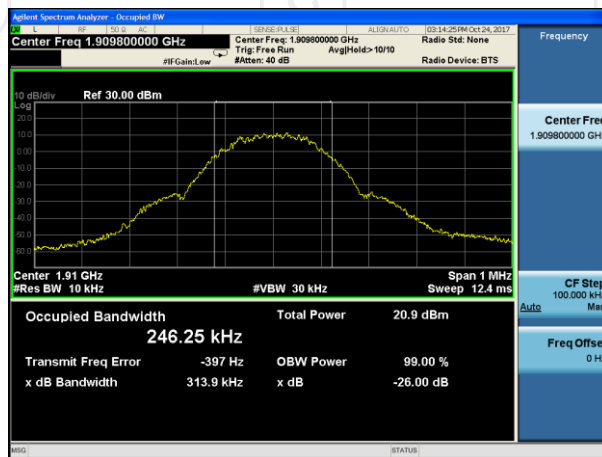

Highest channel

Test band:

WCDMA Band V (RMC 12.2Kbps link)

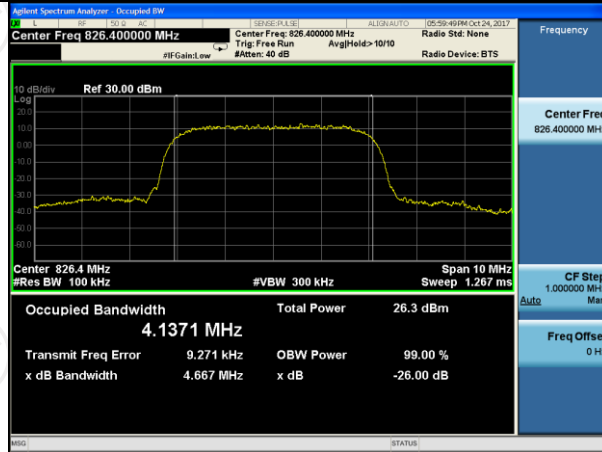

Lowest channel

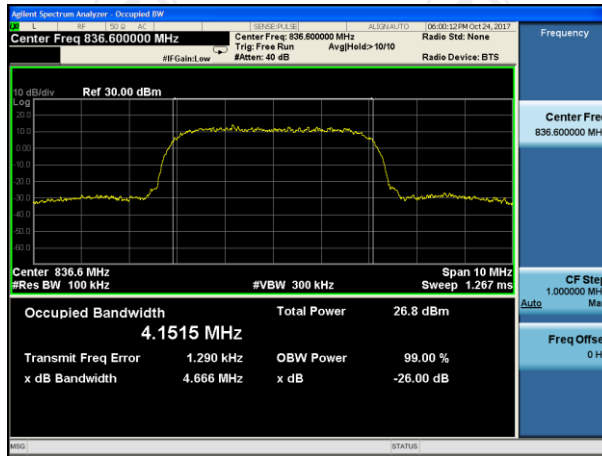

Middle channel

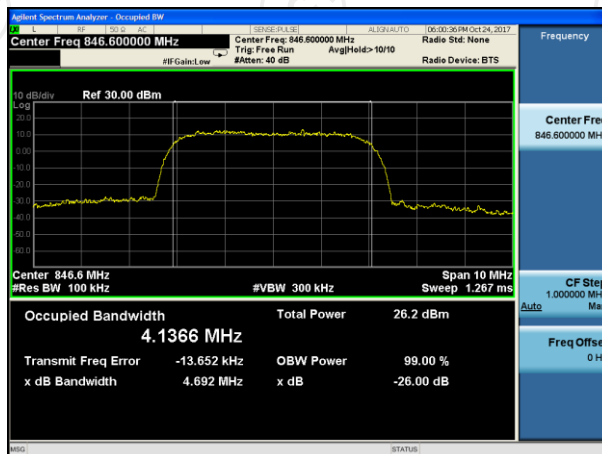

Highest channel

Test band: WCDMA Band II (RMC 12.2Kbps link)

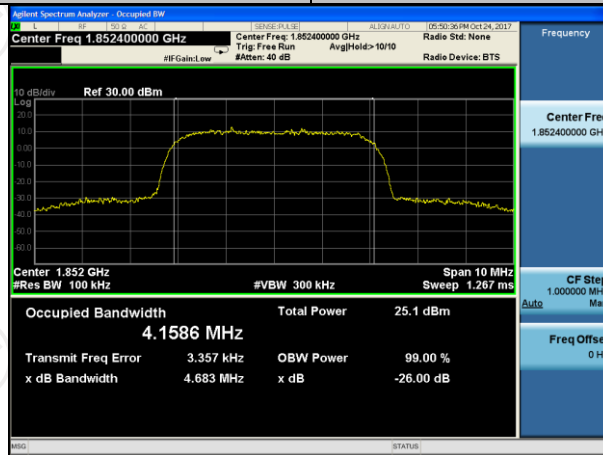

Lowest channel

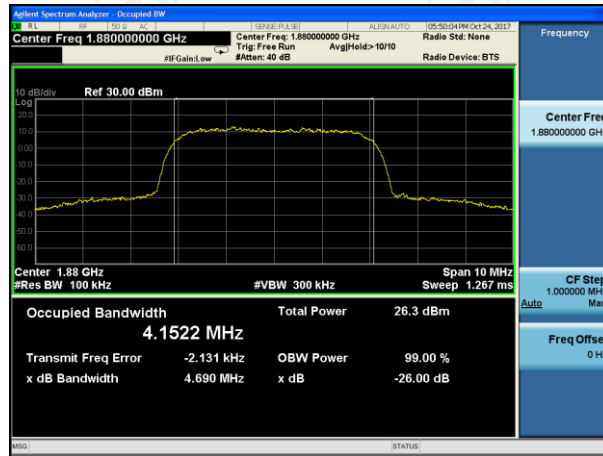

Middle channel

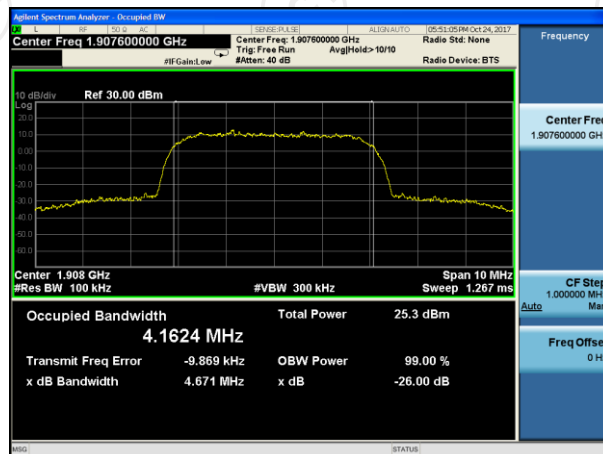

Highest channel

6.4. Band Edge and Conducted Spurious Emission Measurement

6.4.1. Test Specification

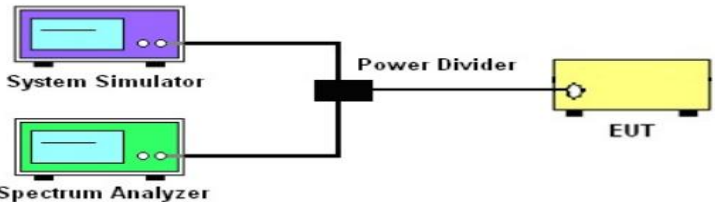
Test Requirement:	FCC part22.917(a) and FCC part24.238(a) FCC part27.53(g)
Test Method:	FCC part2.1051
Operation mode:	Refer to item 4.1
Limit:	-13dBm
Test Setup:	 <p>The diagram illustrates the test setup. A System Simulator (purple box) and a Spectrum Analyzer (green box) are connected to a Power Divider (black box). The Power Divider is then connected to the EUT (yellow box).</p>
Test Procedure:	<ol style="list-style-type: none"> 1. The testing follows FCC KDB 971168 v02r02 Section 6. 2. The EUT was connected to the spectrum analyzer and system simulator via a power divider. 3. The RF output of EUT was connected to the spectrum analyzer by an RF cable and attenuator. The path loss was compensated to the results for each measurement. 4. The band edges of low and high channels for the highest RF powers were measured. 5. The conducted spurious emission for the whole frequency range was taken. 6. The RF fundamental frequency should be excluded against the limit line in the operating frequency band. 7. The limit line is derived from $43 + 10\log(P)$ dB below the transmitter power $P(\text{Watts}) = P(\text{W}) - [43 + 10\log(P)] (\text{dB}) = [30 + 10\log(P)] (\text{dBm}) - [43 + 10\log(P)] (\text{dB}) = -13\text{dBm}.$
Test Result:	PASS

6.4.2. Test Instruments

Equipment	Manufacturer	Model	Serial Number	Calibration Due
System simulator	R&S	CMU200	111382	Sep. 27, 2018
Spectrum Analyzer	Agilent	N9020A	MY49100060	Sep. 27, 2018
RF cable (9kHz-40GHz)	TCT	RE-05	N/A	Sep. 27, 2018
Antenna Connector	TCT	RFC-02	N/A	Sep. 27, 2018

Note: The calibration interval of the above test instruments is 12 months and the calibrations are traceable to international system unit (SI).

6.4.3. Test Data

Test plots as follows:

Test Mode: Traffic mode GSM 850 (GSM link)

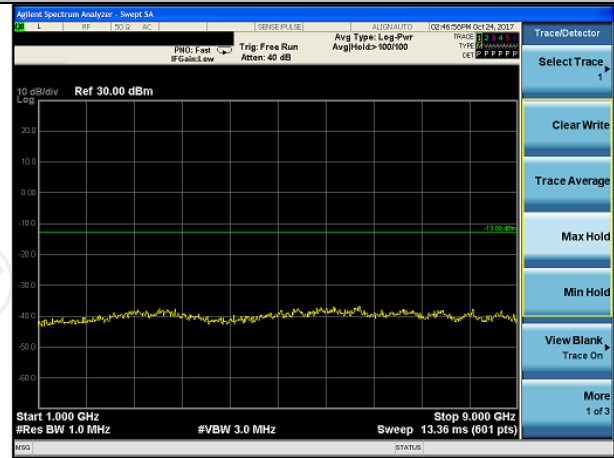
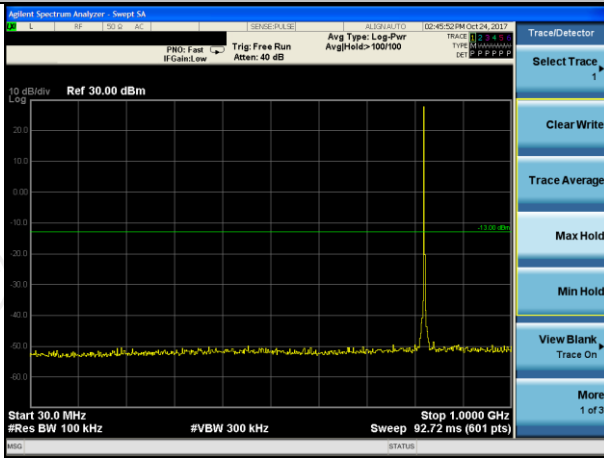

Lowest channel

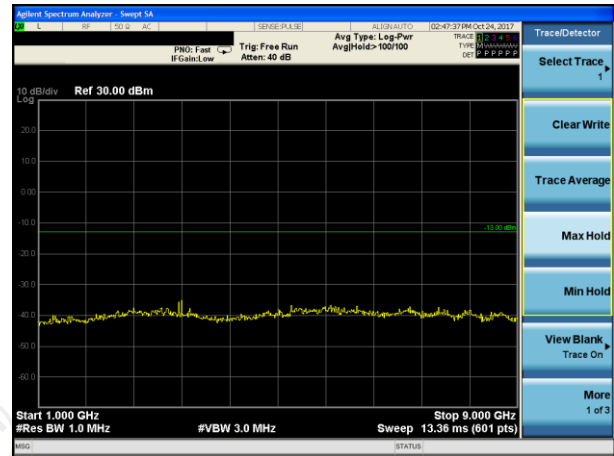
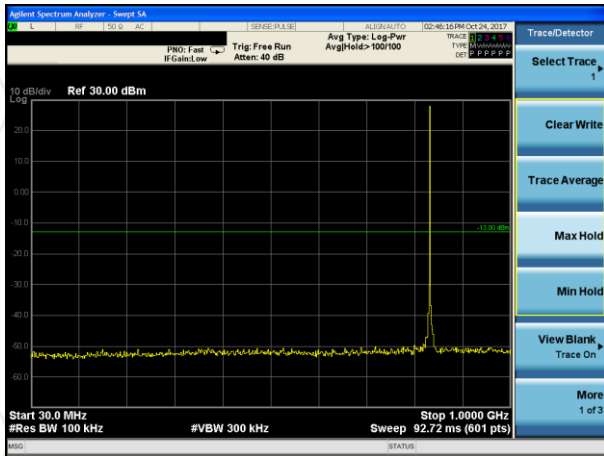

Middle channel

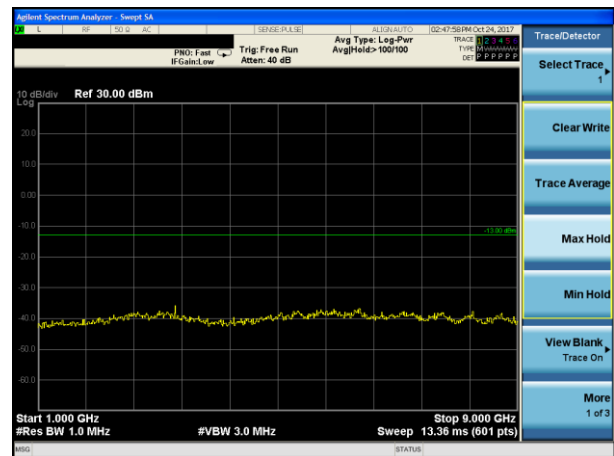
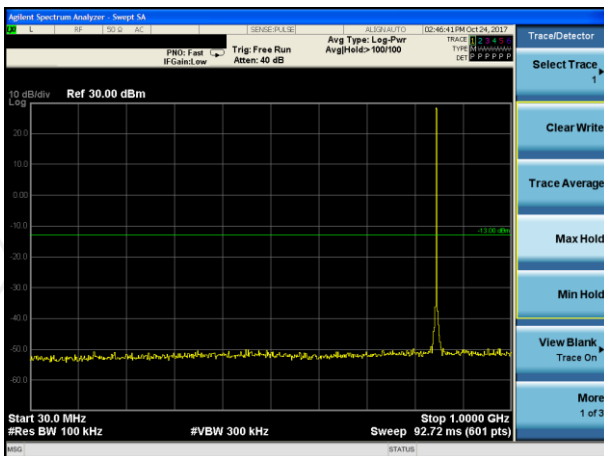

Highest channel

Test Mode: Traffic mode

GSM 850 (GPRS 1 link)

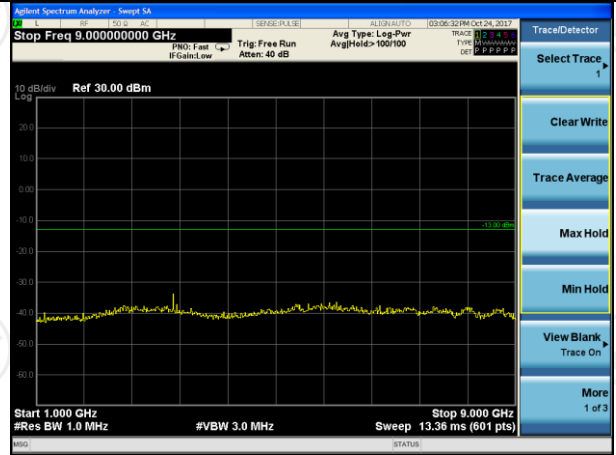
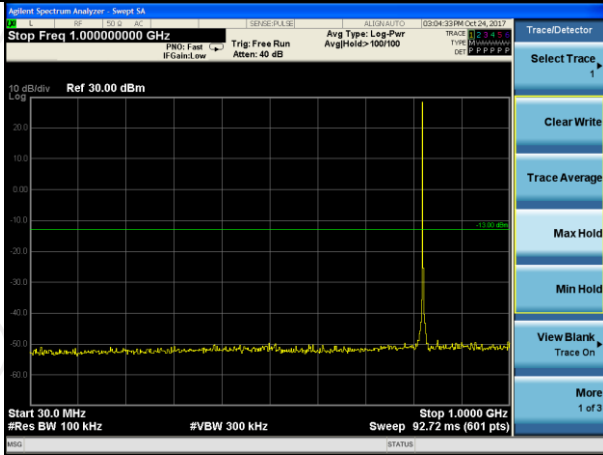

Lowest channel

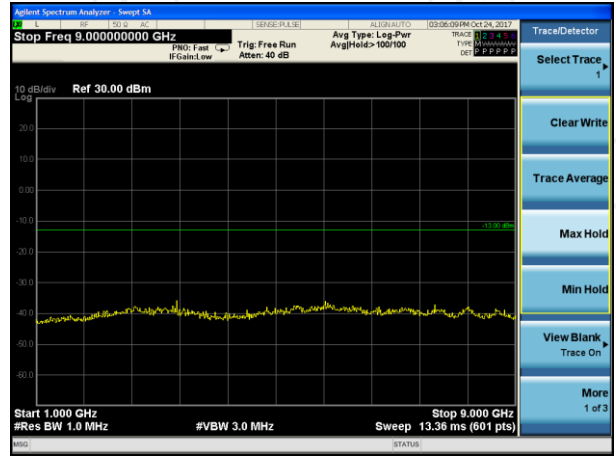
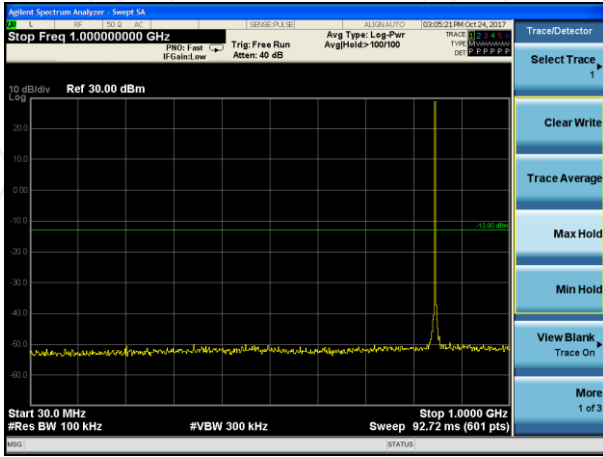

Middle channel

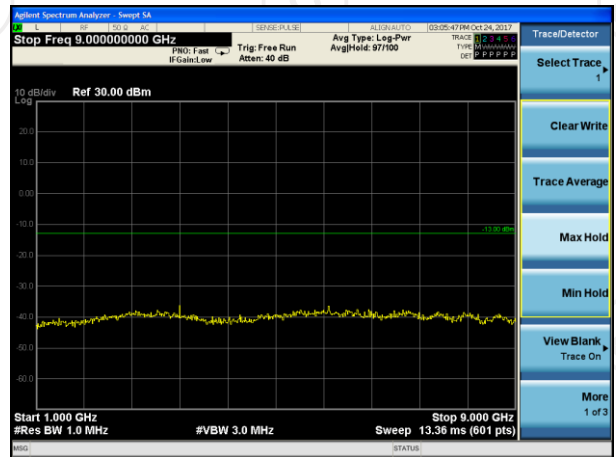
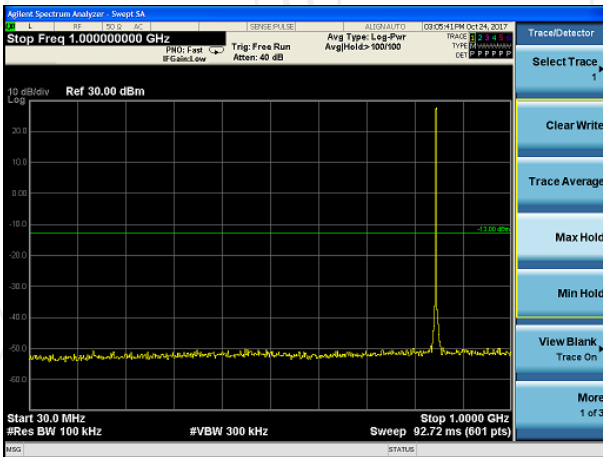

Highest channel

Test Mode: Traffic mode

GSM 850 (EGPRS 1 link)

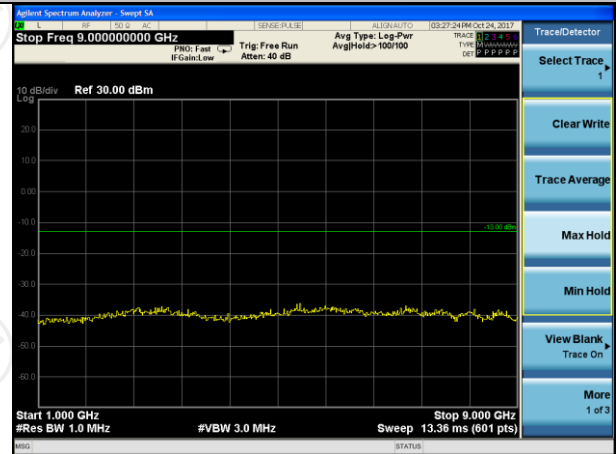
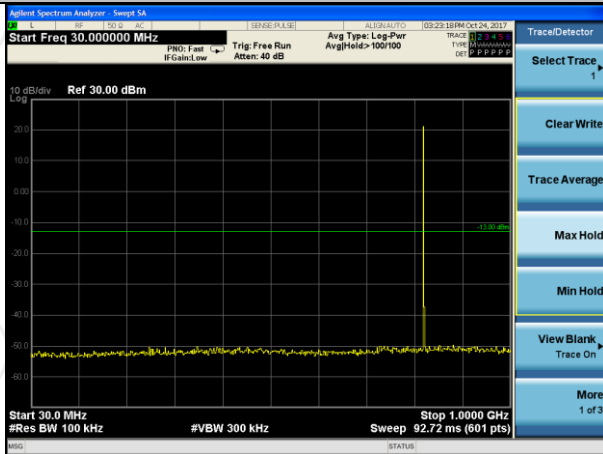

Lowest channel

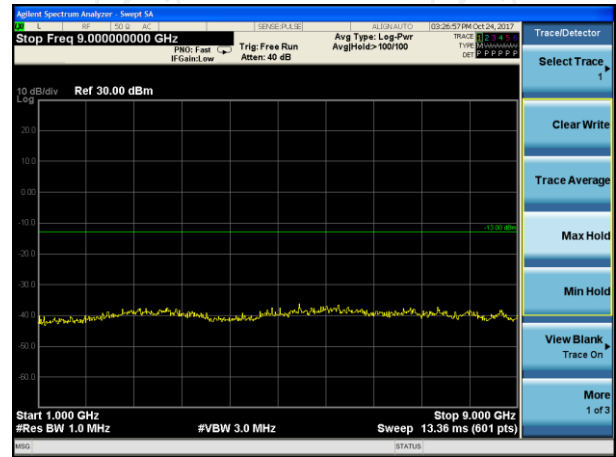
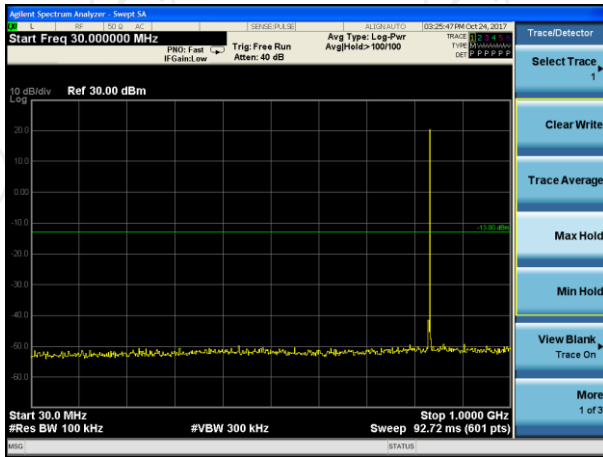

Middle channel

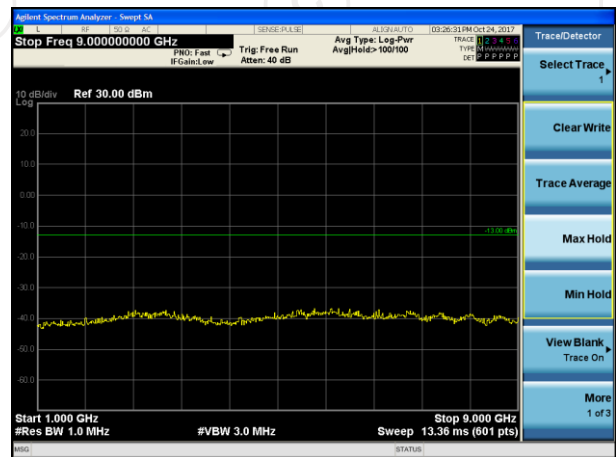
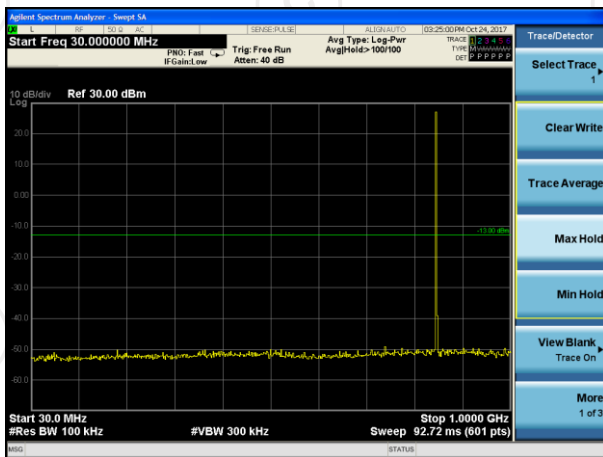

Highest channel

Test Mode: Traffic mode

PCS1900 (GSM link)

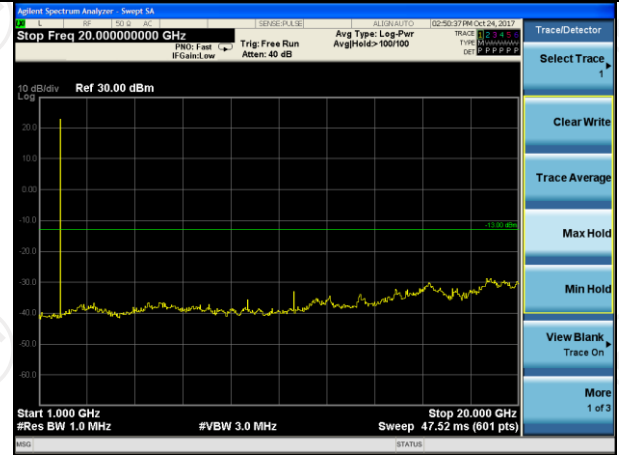
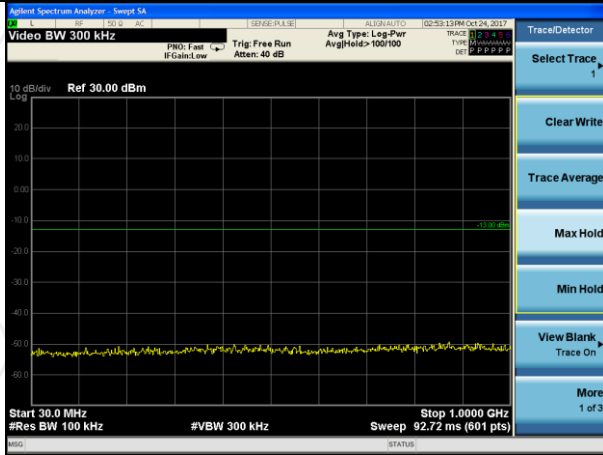

Lowest channel

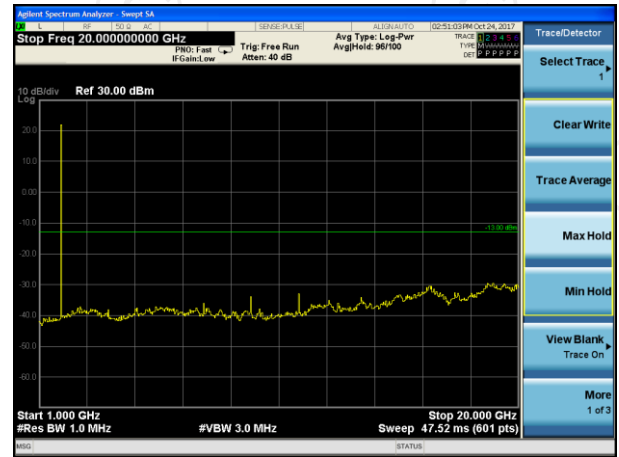
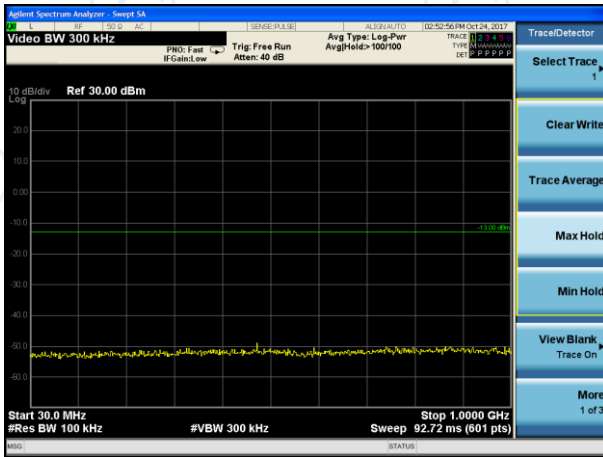

Middle channel

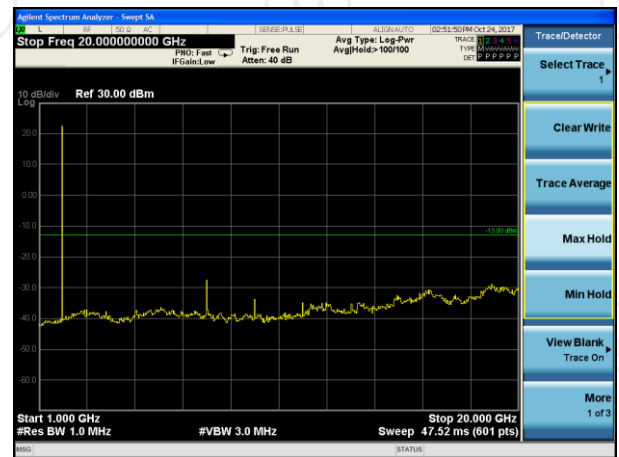
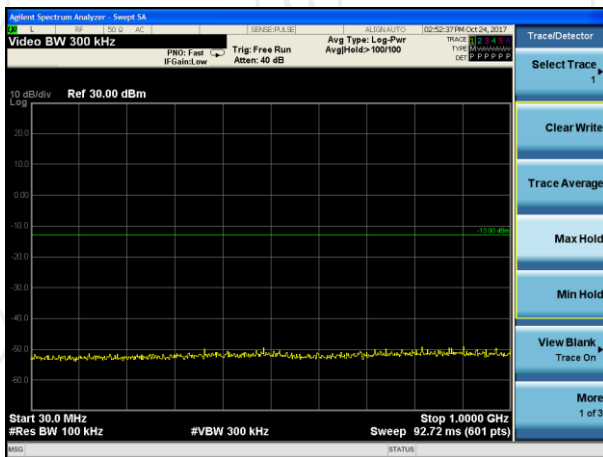

Highest channel

Test Mode: Traffic mode

PCS1900 (GPRS 1 link)

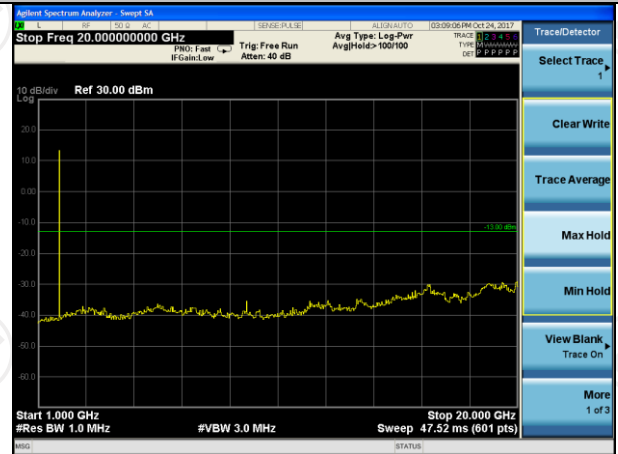
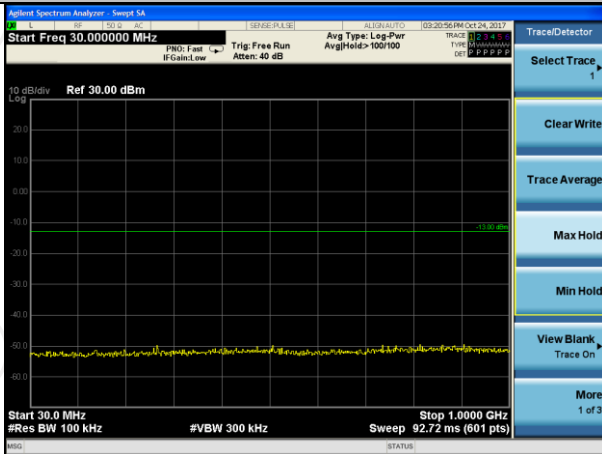

Lowest channel

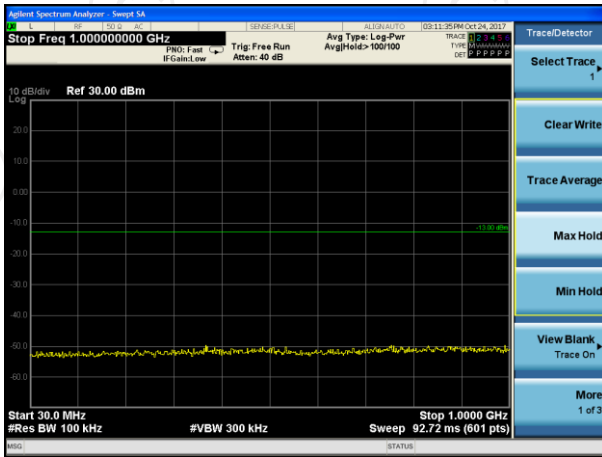

Middle channel

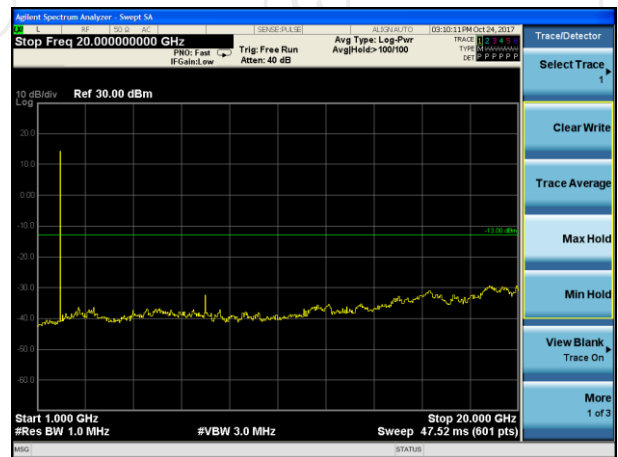
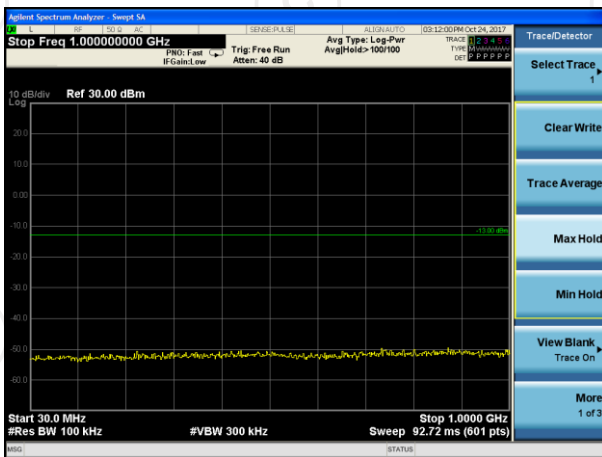

Highest channel

Test Mode: Traffic mode

WCDMA Band V (RMC 12.2Kbps link)

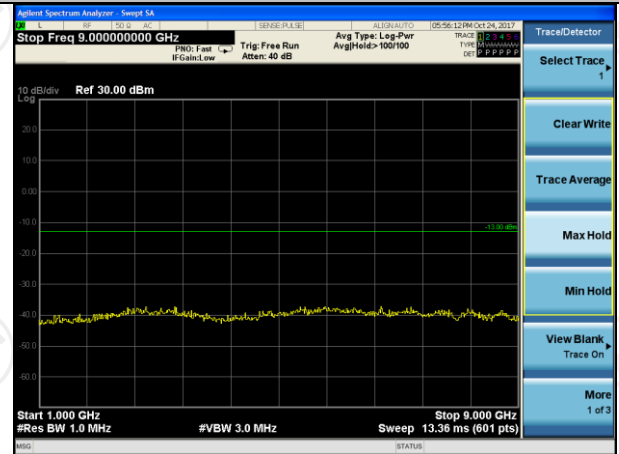
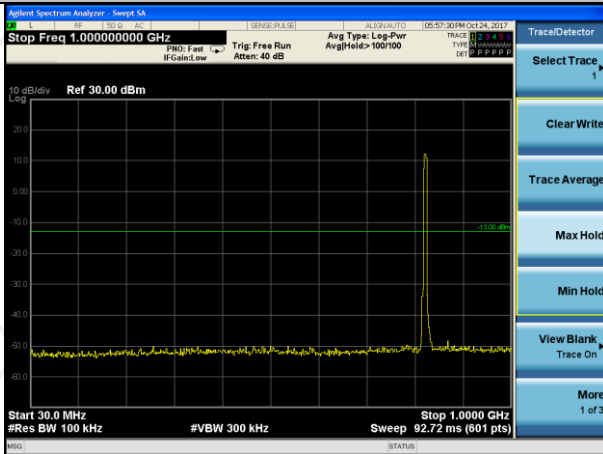

Lowest channel

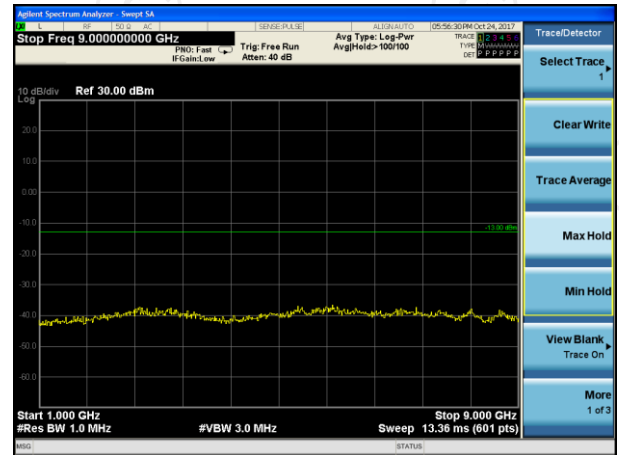
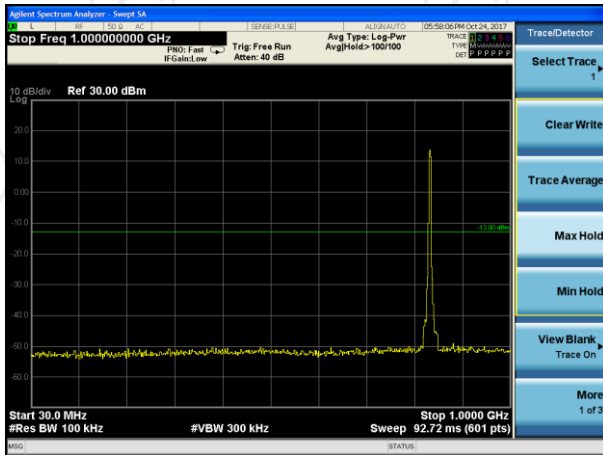

Middle channel

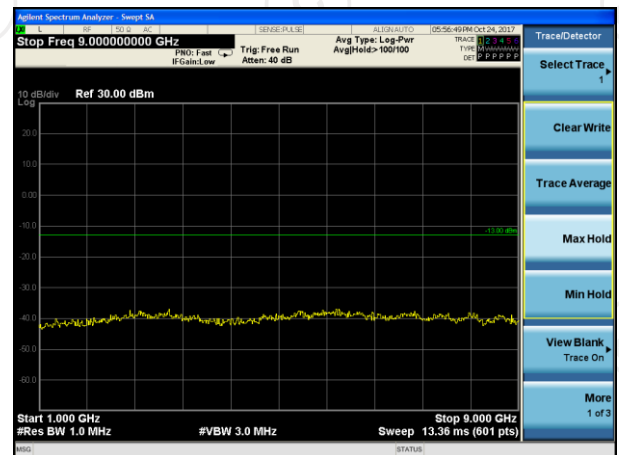
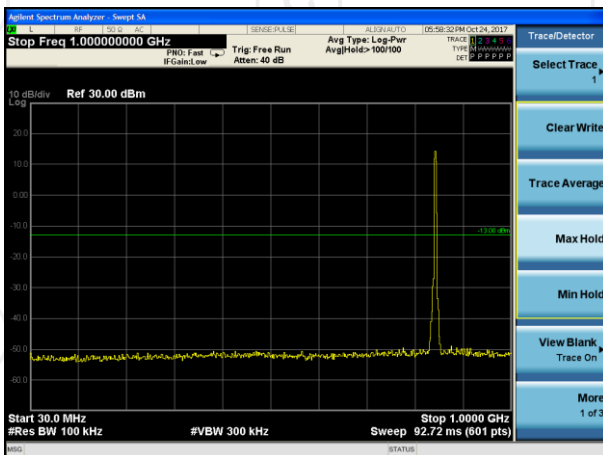

Highest channel

Test Mode: Traffic mode

WCDMA Band II (RMC 12.2Kbps link)

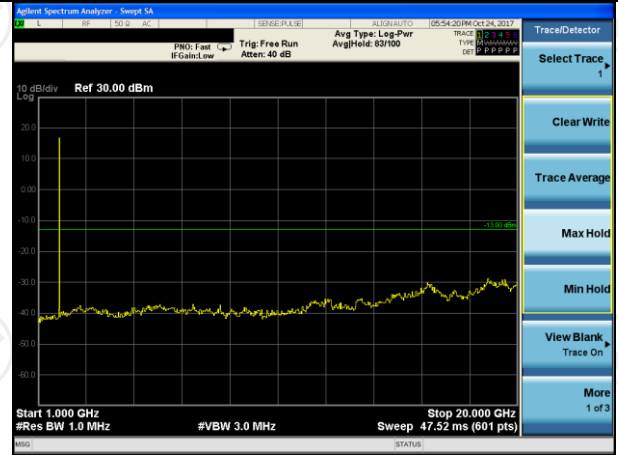
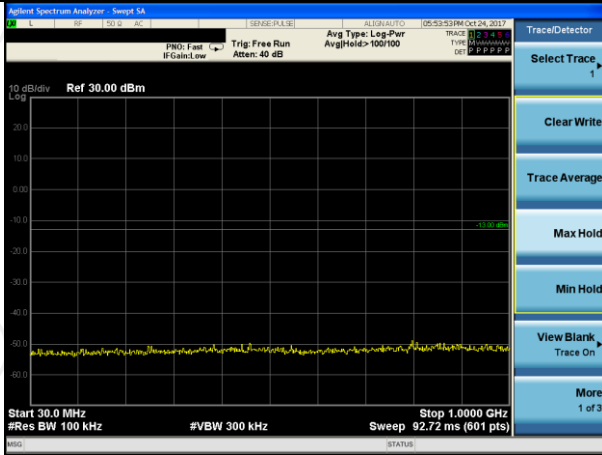

Lowest channel

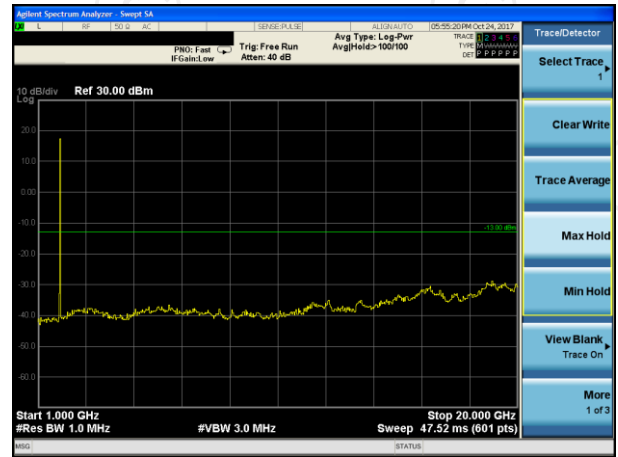
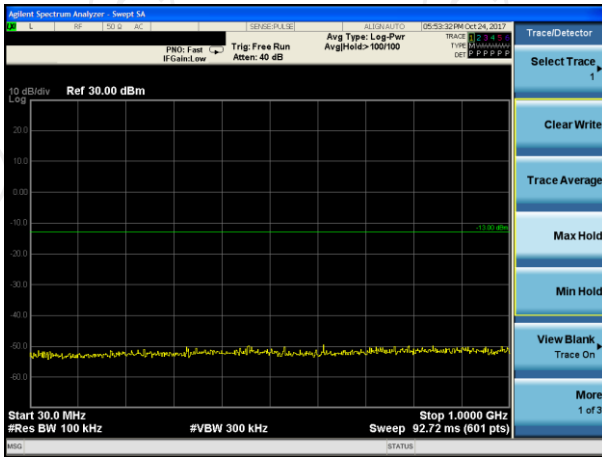

Middle channel

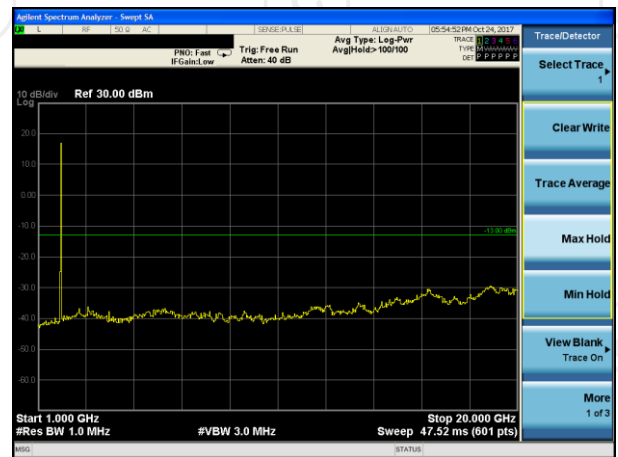
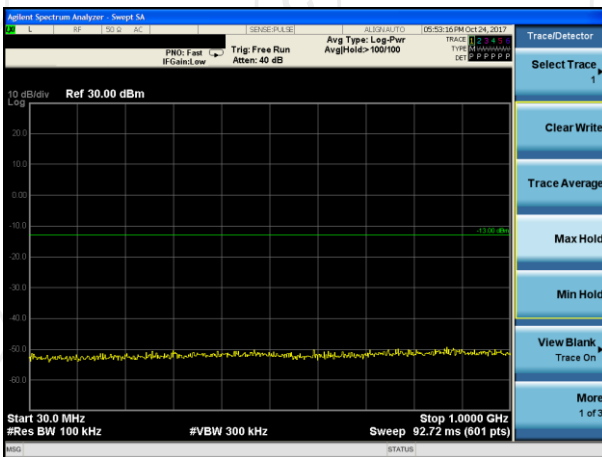

Highest channel

Band Edge:

Test Mode: Traffic mode GSM850 (GSM link)

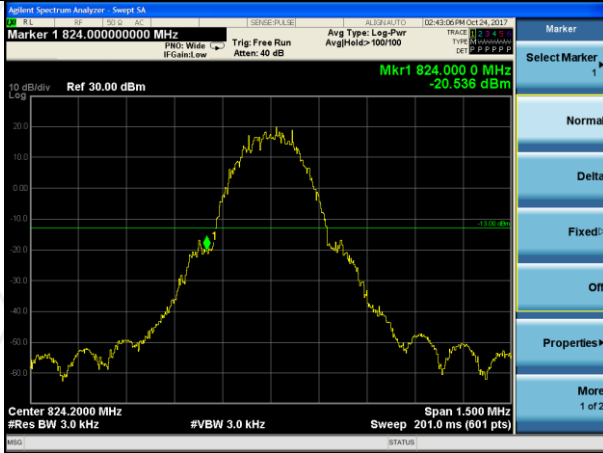

Lowest channel

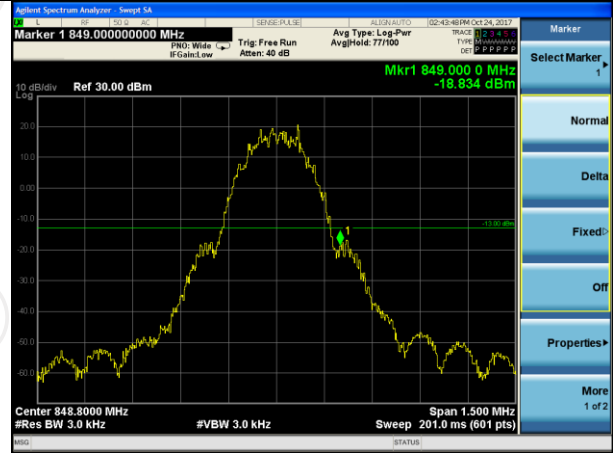

Highest channel

Test Mode: Traffic mode GSM850 (GPRS 1 link)

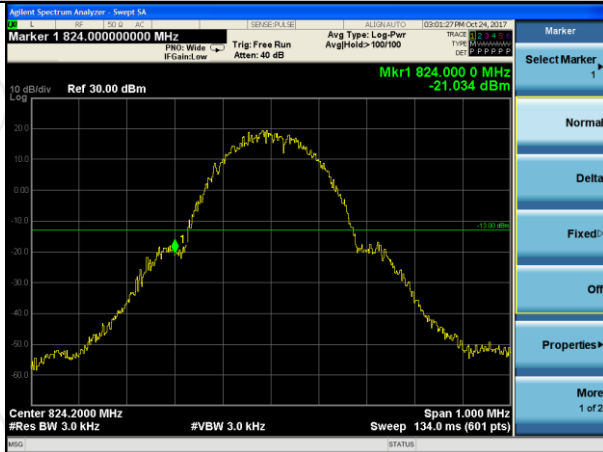

Lowest channel

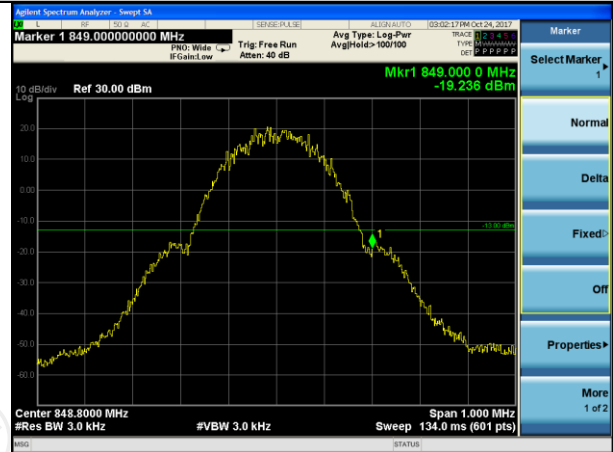

Highest channel

Test Mode: Traffic mode GSM850 (EGPRS 1 link)



Lowest channel



Highest channel

Test Mode: Traffic mode PCS1900 (GSM link)

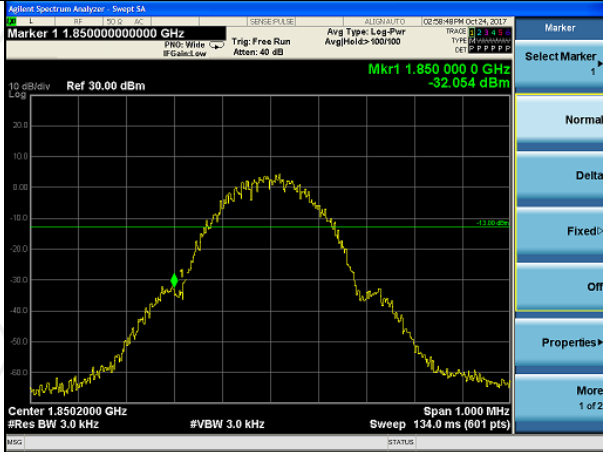

Lowest channel

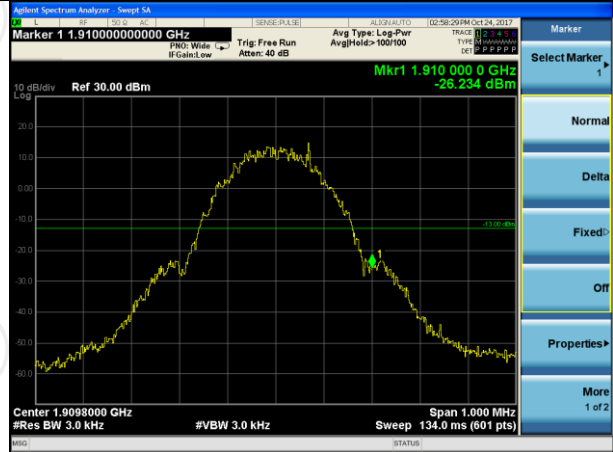

Highest channel

Test Mode: Traffic mode PCS1900 (GPRS 1 link)

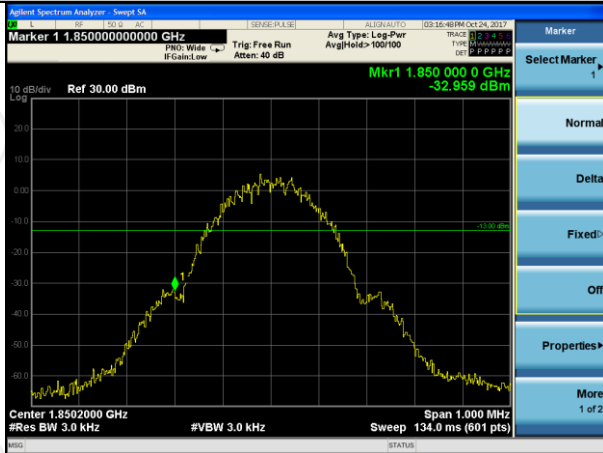

Lowest channel

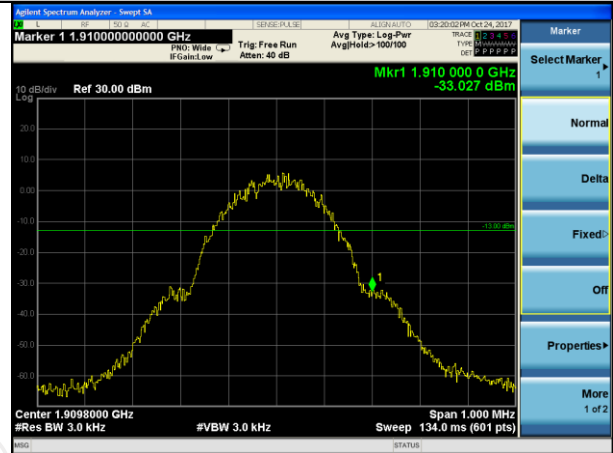

Highest channel

Test Mode: Traffic mode WCDMA Band V (RMC 12.2Kbps link)

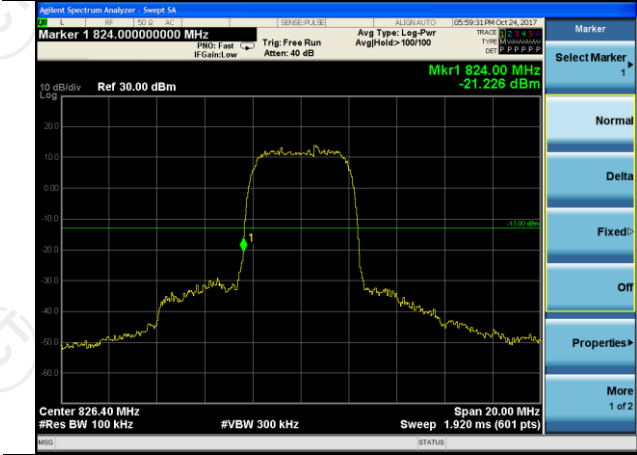

Lowest channel

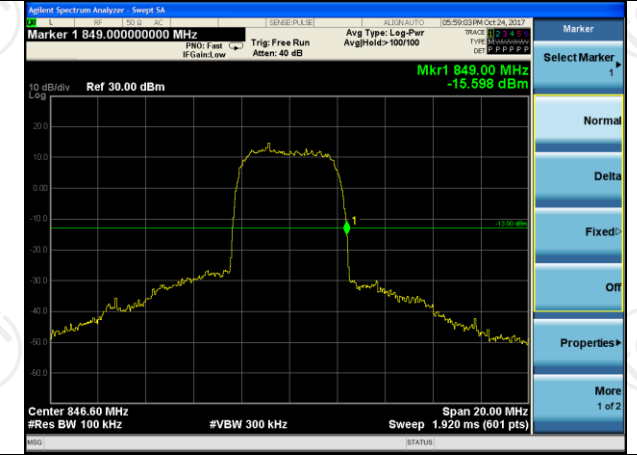

Highest channel

Test Mode: Traffic mode WCDMA Band II (RMC 12.2Kbps link)

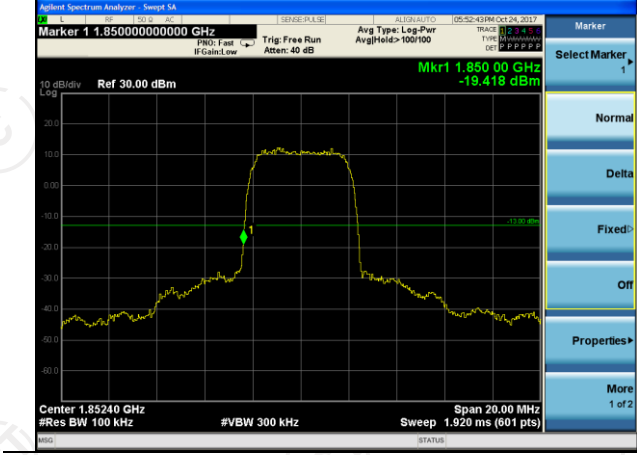

Lowest channel

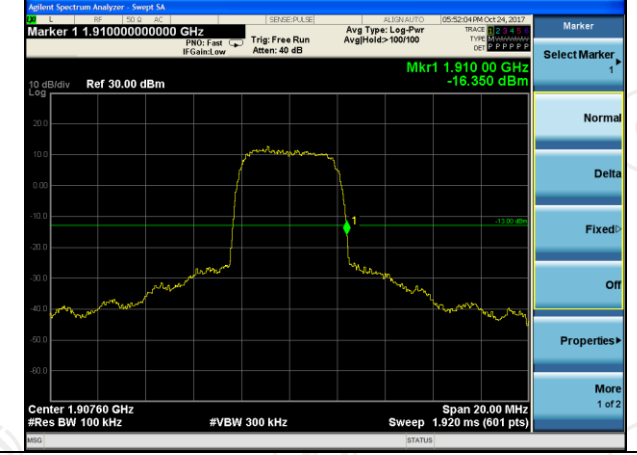

Highest channel

6.5. Effective Radiated Power and Effective Isotropic Radiated Power Measurement

6.5.1. Test Specification

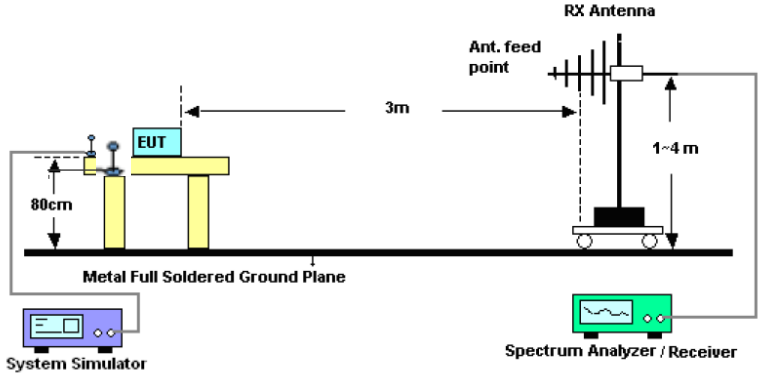
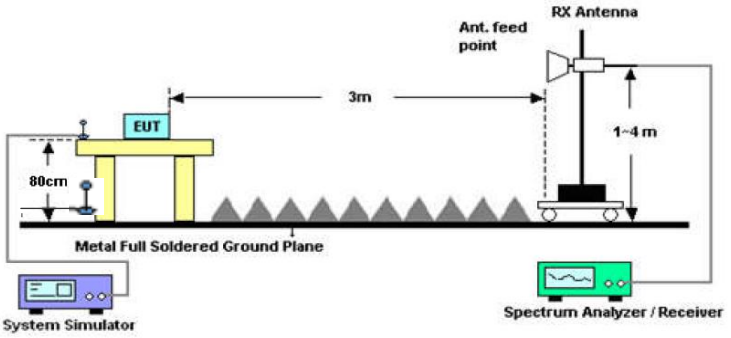
Test Requirement:	FCC part 22.913(a) and FCC part 24.232(b) FCC part 27.50(d)		
Test Method:	FCC part 2.1046		
Receiver Setup:		GSM/GPRS/EDGE	WCDMA/HSPA
	SPAN	500kHz	10MHz
	RBW	10kHz	100kHz
	VBW	30kHz	300kHz
	Detector	RMS	RMS
	Trace	Average	Average
	Average Type	Power	Power
	Sweep Count	100	100
Limit:	GSM850 7W ERP PCS1900 2W EIRP WCDMA Band V: 7W ERP WCDMA Band II: 2W EIRP		
Test Setup:	From 30MHz to 1GHz		
			
Test Setup:	Above 1GHz		
			
Test Procedure:	1. The testing follows FCC KDB 971168 v02r02 Section 5.8. and ANSI / TIA-603-D-2010 Section 2.2.17.		

	<p>2. The EUT was placed on a non-conductive rotating platform 0.8 meters high in a semi-anechoic chamber. The radiated emission at the fundamental frequency was measured at 3 m with a test antenna and a spectrum analyzer with RMS detector per section 5. of KDB 971168 D01.</p> <p>3. Key the transmitter, then rotate the EUT 360° azimuthally and record spectrum analyzer power level (LVL) measurements at angular increments that are sufficiently small to permit resolution of all peaks. If a standard radiation test site is used, raise and lower the test antenna to obtain a maximum reading at each angular increment.</p> <p>4. Replace the transmitter under test with a substitution antenna. The center of the antenna should be at the same location as the center of the antenna under test.</p> <p>5. Connect the antenna to a signal generator with a known output power and record the path loss (in dB) as LOSS. If a standard radiation test site is used, raise and lower the test antenna to obtain a maximum reading.</p> <p style="padding-left: 20px;">LOSS = Generator Output Power (dBm) – Analyzer reading (dBm)</p> <p>6. Determine the effective radiated output power at each angular position from the readings in steps 3) and 5) using the following equation: ERP (dBm) = LVL (dBm) + LOSS (dB)</p> <p>7. The maximum ERP is the maximum value determined in the preceding step.</p> <p>8. Calculating ERP: ERP (dBm) = Output Power (dBm) - Losses (dB) + Antenna Gain (dBd) Antenna Gain (dBd) = Antenna Gain (dBi) - 2.15 EIRP = ERP – 2.15</p>
Test results:	PASS

6.5.2. Test Instruments

Radiated Emission Test Site (966)				
Name of Equipment	Manufacturer	Model	Serial Number	Calibration Due
System simulator	R&S	CMU200	111382	Sep. 27, 2018
Spectrum Analyzer	ROHDE&SCHW ARZ	R&S	FSQ	Sep. 27, 2018
Signal Generator	HP	83623B	3614A00396	Sep. 27, 2018
Broadband Antenna	Schwarzbeck	VULB9163	340	Sep. 27, 2018
Horn Antenna	Schwarzbeck	BBHA 9120D	631	Sep. 27, 2018
Broadband Antenna	Schwarzbeck	VULB9163	412	Sep. 27, 2018
Horn Antenna	Schwarzbeck	BBHA 9120D	1201	Mar. 05, 2018
Dipole Antenna	TCT	TCT-RF	N/A	Sep. 27, 2018
Coax cable (9kHz-1GHz)	TCT	RE-low-01	N/A	Sep. 27, 2018
Coax cable (9kHz-40GHz)	TCT	RE-high-02	N/A	Sep. 27, 2018
Coax cable (9kHz-1GHz)	TCT	RE-low-03	N/A	Sep. 27, 2018
Coax cable (9kHz-40GHz)	TCT	RE-High-04	N/A	Sep. 27, 2018
Antenna Mast	Keleto	CC-A-4M	N/A	N/A
EMI Test Software	Shurple Technology	EZ-EMC	N/A	N/A

Note: The calibration interval of the above test instruments is 12 months and the calibrations are traceable to international system unit (SI).

6.5.3. Test Data

EUT mode	Channel	EUT Pol.	Antenna Pol.	ERP(dBm)	Limit (dBm)	Result
GSM850 (GSM link)	Lowest	H	V	31.70	38.45	Pass
			H	28.55		
		E1	V	23.16		
			H	28.66		
		E2	V	22.16		
			H	26.21		
	Middle	H	V	31.47	38.45	Pass
			H	28.24		
		E1	V	22.92		
			H	28.46		
		E2	V	23.72		
			H	26.70		
	Highest	H	V	31.90	38.45	Pass
			H	28.11		
		E1	V	23.01		
			H	27.50		
		E2	V	22.13		
			H	27.48		

EUT mode	Channel	EUT Pol.	Antenna Pol.	ERP(dBm)	Limit (dBm)	Result
GSM850 (GPRS 1 link)	Lowest	H	V	31.20	38.45	Pass
			H	28.01		
		E1	V	22.57		
			H	28.03		
		E2	V	21.49		
			H	25.50		
	Middle	H	V	30.82	38.45	Pass
			H	27.50		
		E1	V	22.12		
			H	27.62		
		E2	V	22.99		
			H	25.92		
	Highest	H	V	31.26	38.45	Pass
			H	27.42		
		E1	V	22.29		
			H	26.73		
		E2	V	21.56		
			H	26.86		

EUT mode	Channel	EUT Pol.	Antenna Pol.	ERP(dBm)	Limit (dBm)	Result
GSM850 (EGPRS 1 link)	Lowest	H	V	27.68	38.45	Pass
			H	24.66		
		E1	V	19.31		
			H	25.22		
		E2	V	18.73		
			H	23.15		
	Middle	H	V	28.03	38.45	Pass
			H	25.21		
		E1	V	20.00		
			H	25.95		
		E2	V	20.49		
			H	23.79		
	Highest	H	V	28.24	38.45	Pass
			H	24.55		
		E1	V	19.52		
			H	24.38		
		E2	V	19.82		
			H	23.57		

EUT mode	Channel	EUT Pol.	Antenna Pol.	EIRP (dBm)	Limit (dBm)	Result
PCS1900 (GSM link)	Lowest	H	V	28.59	33.01	Pass
			H	25.84		
		E1	V	21.08		
			H	26.10		
		E2	V	20.34		
			H	24.05		
	Middle	H	V	28.70	33.01	Pass
			H	25.98		
		E1	V	21.32		
			H	26.36		
		E2	V	21.92		
			H	24.66		
	Highest	H	V	29.17	33.01	Pass
			H	25.84		
		E1	V	21.37		
			H	25.46		
		E2	V	20.30		
			H	25.17		

EUT mode	Channel	EUT Pol.	Antenna Pol.	EIRP (dBm)	Limit (dBm)	Result
PCS1900 (GPRS 1 link)	Lowest	H	V	28.20	33.01	Pass
			H	25.42		
		E1	V	20.64		
			H	25.62		
		E2	V	19.84		
			H	23.52		
	Middle	H	V	28.21	33.01	Pass
			H	25.43		
		E1	V	20.73		
			H	25.75		
		E2	V	21.38		
			H	24.09		
	Highest	H	V	28.69	33.01	Pass
			H	25.33		
		E1	V	20.83		
			H	24.89		
		E2	V	19.86		
			H	24.71		

EUT mode	Channel	EUT Pol.	Antenna Pol.	ERP(dBm)	Limit (dBm)	Result
WCDMA Band V	Lowest	H	V	23.49	38.45	Pass
			H	21.36		
		E1	V	17.79		
			H	21.19		
		E2	V	16.91		
			H	19.39		
	Middle	H	V	23.06	38.45	Pass
			H	20.74		
		E1	V	17.19		
			H	20.61		
		E2	V	17.87		
			H	19.66		
	Highest	H	V	21.98	38.45	Pass
			H	19.44		
		E1	V	16.06		
			H	18.81		
		E2	V	15.91		
			H	19.21		

EUT mode	Channel	EUT Pol.	Antenna Pol.	EIRP(dBm)	Limit (dBm)	Result
WCDMA Band II	Lowest	H	V	23.44	33.01	Pass
			H	21.31		
		E1	V	17.73		
			H	21.12		
		E2	V	16.84		
			H	19.31		
	Middle	H	V	23.00	33.01	Pass
			H	20.65		
		E1	V	17.10		
			H	20.51		
		E2	V	17.79		
			H	19.57		
	Highest	H	V	21.91	33.01	Pass
			H	19.37		
		E1	V	15.98		
			H	18.73		
		E2	V	15.86		
			H	19.15		

6.6. Field Strength of Spurious Radiation Measurement

6.6.1. Test Specification

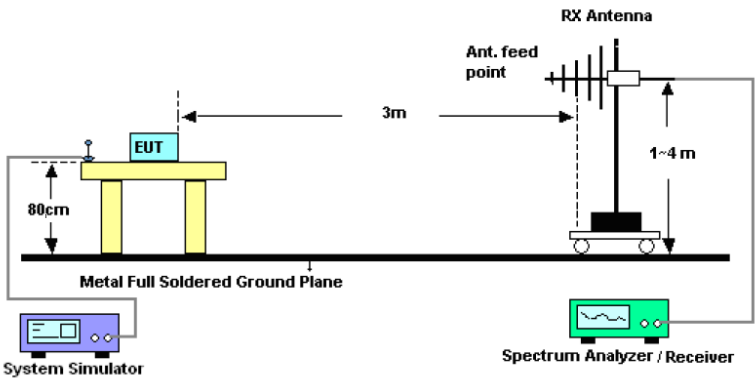
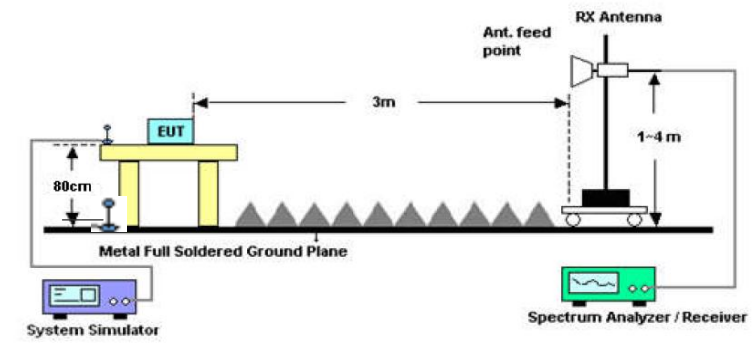
Test Requirement:	FCC part 22.917(a) and FCC part 24.238(a) FCC part 27.53(g)
Test Method:	FCC part 2.1053
Operation mode:	Refer to item 4.1
Limit:	-13dBm
Test setup:	<p>For 30MHz~1GHz</p>  <p>Above 1GHz</p> 
Test Procedure:	<ol style="list-style-type: none"> 1. The testing follows FCC KDB 971168 v02r02 Section 5.8 and ANSI / TIA-603-D-2010 Section 2.2.12. 2. The EUT was placed on a rotatable wooden table 0.8 meters above the ground. 3. The EUT was set 3 meters from the receiving antenna, which was mounted on the antenna tower. 4. The table was rotated 360 degrees to determine the position of the highest spurious emission. 5. The height of the receiving antenna is varied between one meter and four meters to search for the maximum spurious emission for both horizontal and vertical polarizations. 6. Make the measurement with the spectrum analyzer's

	<p>RBW = 1MHz, VBW = 3MHz, taking record of maximum spurious emission.</p> <p>7. A horn antenna was substituted in place of the EUT and was driven by a signal generator.</p> <p>8. Tune the output power of signal generator to the same emission level with EUT maximum spurious emission.</p> <p>9. Taking the record of output power at antenna port.</p> <p>10. Repeat step 7 to step 8 for another polarization.</p> <p>11. EIRP (dBm) = S.G. Power – Tx Cable Loss + Tx Antenna Gain</p> <p>12. ERP (dBm) = EIRP - 2.15</p> <p>13. The RF fundamental frequency should be excluded against the limit line in the operating frequency band.</p> <p>14. The limit line is derived from 43 + 10log(P) dB below the transmitter power P(Watts)</p> <p>= P(W) - [43 + 10log(P)] (dB)</p> <p>= [30 + 10log(P)] (dBm) - [43 + 10log(P)] (dB)</p> <p>= -13dBm.</p>
Test results:	PASS
Remark:	All modulations have been tested, but only the worst modulation show in this test item.

6.6.2. Test Instruments

Radiated Emission Test Site (966)				
Name of Equipment	Manufacturer	Model	Serial Number	Calibration Due
System simulator	R&S	CMU200	111382	Sep. 27, 2018
Spectrum Analyzer	ROHDE&SCHW ARZ	R&S	FSQ	Sep. 27, 2018
Signal Generator	HP	83623B	3614A00396	Sep. 27, 2018
Broadband Antenna	Schwarzbeck	VULB9163	340	Sep. 27, 2018
Horn Antenna	Schwarzbeck	BBHA 9120D	631	Sep. 27, 2018
Broadband Antenna	Schwarzbeck	VULB9163	412	Sep. 27, 2018
Horn Antenna	Schwarzbeck	BBHA 9120D	1201	Mar. 05, 2018
Horn Antenna	Schwarzbeck	BBH 9170	582	Jun. 07, 2018
Dipole Antenna	TCT	TCT-RF	N/A	Sep. 27, 2018
Coax cable (9kHz-1GHz)	TCT	RE-low-01	N/A	Sep. 27, 2018
Coax cable (9kHz-40GHz)	TCT	RE-high-02	N/A	Sep. 27, 2018
Coax cable (9kHz-1GHz)	TCT	RE-low-03	N/A	Sep. 27, 2018
Coax cable (9kHz-40GHz)	TCT	RE-High-04	N/A	Sep. 27, 2018
Antenna Mast	Keleto	CC-A-4M	N/A	N/A
EMI Test Software	Shurple Technology	EZ-EMC	N/A	N/A

Note: The calibration interval of the above test instruments is 12 months and the calibrations are traceable to international system unit (SI).

6.6.3. Test Data

Test mode:	GSM850		Test channel:	Lowest
Frequency (MHz)	Spurious Emission		Limit (dBm)	Result
	Polarization	Level (dBm)		
1648.40	Vertical	-34.32	-13.00	Pass
2472.60	V	-37.13		
3296.80	V	-39.47		
4121.00	V	-41.66		
4945.20	V	---		
1648.40	Horizontal	-39.69	-13.00	Pass
2472.60	H	-43.65		
3296.80	H	-45.30		
4121.00	H	-48.13		
4945.20	H	---		
Test mode:	GSM850		Test channel:	Middle
Frequency (MHz)	Spurious Emission		Limit (dBm)	Result
	Polarization	Level (dBm)		
1673.20	Vertical	-35.99	-13.00	Pass
2509.80	V	-38.33		
3346.40	V	-40.28		
4183.00	V	-42.11		
5019.60	V	---		
1673.20	Horizontal	-40.47	-13.00	Pass
2509.80	H	-43.77		
3346.40	H	-45.14		
4183.00	H	-47.50		
5019.60	H	---		
Test mode:	GSM850		Test channel:	Highest
Frequency (MHz)	Spurious Emission		Limit (dBm)	Result
	Polarization	Level (dBm)		
1697.60	Vertical	-36.47	-13.00	Pass
2546.40	V	-38.55		
3395.20	V	-40.27		
4244.00	V	-41.90		
5092.80	V	---		
1697.60	Horizontal	-40.44	-13.00	Pass
2546.40	H	-43.38		
3395.20	H	-44.58		
4244.00	H	-46.68		
5092.80	H	---		

Remark :

1. The emission behaviour belongs to narrowband spurious emission.
2. Remark"---" means that the emission level is too low to be measured
3. The emission levels of below 1 GHz are very lower than the limit and not show in test report.

Test mode:	PCS1900		Test channel:	Lowest
Frequency (MHz)	Spurious Emission		Limit (dBm)	Result
	Polarization	Level (dBm)		
3700.40	Vertical	-36.73	-13.00	Pass
5550.60	V	-39.12		
7400.80	V	-41.11		
9251.00	V	-43.01		
11101.20	V	---		
3700.40	Horizontal	-41.33	-13.00	Pass
5550.60	H	-44.72		
7400.80	H	-46.09		
9251.00	H	-48.47		
11101.20	H	---		
Test mode:	PCS1900		Test channel:	Middle
Frequency (MHz)	Spurious Emission		Limit (dBm)	Result
	Polarization	Level (dBm)		
3760.00	Vertical	-34.28	-13.00	Pass
5640.00	V	-36.76		
7520.00	V	-38.82		
9400.00	V	-40.80		
11280.00	V	---		
3760.00	Horizontal	-39.05	-13.00	Pass
5640.00	H	-42.56		
7520.00	H	-43.99		
9400.00	H	-46.48		
11280.00	H	---		
Test mode:	PCS1900		Test channel:	Highest
Frequency (MHz)	Spurious Emission		Limit (dBm)	Result
	Polarization	Level (dBm)		
3819.60	Vertical	-35.54	-13.00	Pass
5729.40	V	-37.95		
7639.20	V	-39.94		
9549.00	V	-41.85		
11458.80	V	---		
3819.60	Horizontal	-40.16	-13.00	Pass
5729.40	H	-43.56		
7639.20	H	-44.94		
9549.00	H	-47.34		
11458.80	H	---		

Remark :

1. The emission behaviour belongs to narrowband spurious emission.
2. Remark"---" means that the emission level is too low to be measured
3. The emission levels of below 1 GHz are very lower than the limit and not show in test report.

Test mode:	WCDMA Band V		Test channel:	Lowest
Frequency (MHz)	Spurious Emission		Limit (dBm)	Result
	Polarization	Level (dBm)		
1652.80	Vertical	-36.16	-13.00	Pass
2479.20	V	-39.96		
3305.60	V	-42.75		
4132.00	V	-40.30		
4958.40	V	---		
1652.80	Horizontal	-39.06	-13.00	Pass
2479.20	H	-41.82		
3305.60	H	-47.29		
4132.00	H	-50.99		
4958.40	H	---		
Test mode:	WCDMA Band V		Test channel:	Middle
Frequency (MHz)	Spurious Emission		Limit (dBm)	Result
	Polarization	Level (dBm)		
1672.80	Vertical	-38.42	-13.00	Pass
2509.20	V	-39.77		
3345.60	V	-43.44		
4182.00	V	-45.93		
5018.40	V	---		
1672.80	Horizontal	-40.95	-13.00	Pass
2509.20	H	-42.92		
3345.60	H	-47.65		
4182.00	H	-50.10		
5018.40	H	---		
Test mode:	WCDMA Band V		Test channel:	Highest
Frequency (MHz)	Spurious Emission		Limit (dBm)	Result
	Polarization	Level (dBm)		
1693.20	Vertical	-37.10	-13.00	Pass
2539.80	V	-39.58		
3386.40	V	-42.24		
4233.00	V	-45.15		
5079.60	V	---		
1693.20	Horizontal	-40.51	-13.00	Pass
2539.80	H	-42.98		
3386.40	H	-44.40		
4233.00	H	-50.63		
5079.60	H	---		

Remark :

1. The emission behaviour belongs to narrowband spurious emission.
2. Remark"---" means that the emission level is too low to be measured
3. The emission levels of below 1 GHz are very lower than the limit and not show in test report.

Test mode:	WCDMA Band II		Test channel:	Lowest
Frequency (MHz)	Spurious Emission		Limit (dBm)	Result
	Polarization	Level (dBm)		
3704.80	Vertical	-38.55	-13.00	Pass
5557.20	V	-41.64		
7409.60	V	-44.20		
9262.00	V	-46.66		
11114.40	V	---		
3704.80	Horizontal	-44.48	-13.00	Pass
5557.20	H	-48.85		
7409.60	H	-50.62		
9262.00	H	-53.71		
11114.40	H	---		
Test mode:	WCDMA Band II		Test channel:	Middle
Frequency (MHz)	Spurious Emission		Limit (dBm)	Result
	Polarization	Level (dBm)		
3760.00	Vertical	-39.35	-13.00	Pass
5640.00	V	-42.28		
7520.00	V	-44.70		
9400.00	V	-47.03		
11280.00	V	---		
3760.00	Horizontal	-44.97	-13.00	Pass
5640.00	H	-49.12		
7520.00	H	-50.79		
9400.00	H	-53.72		
11280.00	H	---		
Test mode:	WCDMA Band II		Test channel:	Highest
Frequency (MHz)	Spurious Emission		Limit (dBm)	Result
	Polarization	Level (dBm)		
3815.20	Vertical	-38.64	-13.00	Pass
5722.80	V	-41.37		
7630.40	V	-43.62		
9538.00	V	-45.80		
11445.60	V	---		
3815.20	Horizontal	-43.88	-13.00	Pass
5722.80	H	-47.74		
7630.40	H	-49.30		
9538.00	H	-52.02		
11445.60	H	---		

Remark :

1. The emission behaviour belongs to narrowband spurious emission.
2. Remark"---" means that the emission level is too low to be measured
3. The emission levels of below 1 GHz are very lower than the limit and not show in test report.

6.7. Frequency Stability Measurement

6.7.1. Test Specification

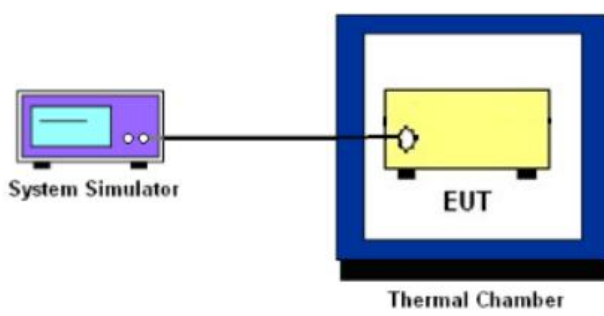
Test Requirement:	FCC Part 2.1055 ; FCC Part 22.355 ; FCC Part 24.235 FCC Part 27.54
Test Method:	FCC Part 2.1055(a)(1)(b)
Operation mode:	Refer to item 4.1
Limit:	±2.5 ppm
Test Setup:	 <p>The diagram illustrates the test setup. On the left, a purple 'System Simulator' is connected via a black cable to a yellow 'EUT' (Equipment Under Test) located inside a blue 'Thermal Chamber'.</p>
Test Procedure:	<p>Test Procedures for Temperature Variation</p> <ol style="list-style-type: none"> 1. The testing follows FCC KDB 971168 v02r02 Section 9.0. 2. The EUT was set up in the thermal chamber and connected with the system simulator. 3. With power OFF, the temperature was decreased to -30°C and the EUT was stabilized before testing. Power was applied and the maximum change in frequency was recorded within one minute. 4. With power OFF, the temperature was raised in 10°C steps up to 50°C. The EUT was stabilized at each step for at least half an hour. Power was applied and the maximum frequency change was recorded within one minute. <p>Test Procedures for Voltage Variation</p> <ol style="list-style-type: none"> 1. The testing follows FCC KDB 971168 v02r02 Section 9.0. 2. The EUT was placed in a temperature chamber at 25±5° C and connected with the system simulator. 3. The power supply voltage to the EUT was varied from BEP to 115% of the nominal value measured at the input to the EUT. 4. The variation in frequency was measured for the worst case.
Test Result:	PASS
Remark:	All three channels of all modulations have been tested, but only the worst channel and the worst modulation show in this test item.

6.7.2. Test Instruments

Equipment	Manufacturer	Model	Serial Number	Calibration Due
System simulator	R&S	CMU200	111382	Sep. 27, 2018
Programable tempratuce and humidity chamber	JQ	JQ-2000	N/A	Sep. 27, 2018
DC power supply	Kingrang	KR3005K 30V/5A	N/A	Sep. 27, 2018
RF cable (9kHz-40GHz)	TCT	RE-04	N/A	Sep. 27, 2018
Antenna Connector	TCT	RFC-03	N/A	Sep. 27, 2018

Note: The calibration interval of the above test instruments is 12 months and the calibrations are traceable to international system unit (SI).

6.7.3. Test Data

Test Result of Temperature Variation

Reference Frequency: GSM850 (GSM link) Middle channel=190 channel=836.6MHz					
Power supplied (Vdc)	Temperature (°C)	Frequency error		Limit (ppm)	Result
		Hz	ppm		
3.80	-30	31	0.0368	2.5	Pass
	-20	35	0.0416		
	-10	29	0.0352		
	0	24	0.0289		
	10	28	0.0336		
	20	24	0.0289		
	30	40	0.0480		
	40	36	0.0432		
	50	35	0.0416		
Reference Frequency: GSM850 (GPRS 1 link) Middle channel=190 channel=836.6MHz					
Power supplied (Vdc)	Temperature (°C)	Frequency error		Limit (ppm)	Result
		Hz	ppm		
3.80	-30	30	0.0354	2.5	Pass
	-20	32	0.0383		
	-10	28	0.0340		
	0	26	0.0311		
	10	27	0.0326		
	20	25	0.0297		
	30	38	0.0454		
	40	33	0.0397		
	50	32	0.0383		
Reference Frequency: GSM850 (EGPRS 1 link) Middle channel=190 channel=836.6MHz					
Power supplied (Vdc)	Temperature (°C)	Frequency error		Limit (ppm)	Result
		Hz	ppm		
3.80	-30	50	0.0597	2.5	Pass
	-20	58	0.0697		
	-10	48	0.0576		
	0	41	0.0494		
	10	47	0.0560		
	20	40	0.0481		
	30	71	0.0846		
	40	61	0.0730		
	50	58	0.0689		

Reference Frequency: PCS1900 (GSM link) Middle channel=661 channel=1880MHz				
Power supplied (Vdc)	Temperature (°C)	Frequency error		Result
		Hz	ppm	
3.80	-30	31	0.0166	2.5 Pass
	-20	39	0.0206	
	-10	31	0.0166	
	0	25	0.0133	
	10	31	0.0166	
	20	26	0.0140	
	30	47	0.0253	
	40	40	0.0213	
	50	37	0.0199	
Reference Frequency: PCS1900 (GPRS 1 link) Middle channel=661 channel=1880MHz				
Power supplied (Vdc)	Temperature (°C)	Frequency error		Result
		Hz	ppm	
3.80	-30	37	0.0197	2.5 Pass
	-20	44	0.0234	
	-10	34	0.0183	
	0	27	0.0146	
	10	36	0.0190	
	20	27	0.0146	
	30	51	0.0271	
	40	41	0.0219	
	50	44	0.0234	

Reference Frequency: WCDMA Band V Middle channel=4183 channel=836.6MHz					
Power supplied (Vdc)	Temperature (°C)	Frequency error		Limit (ppm)	Result
		Hz	ppm		
3.80	-30	87	0.0461	2.5	Pass
	-20	77	0.0411		
	-10	67	0.0357		
	0	63	0.0335		
	10	58	0.0307		
	20	51	0.0269		
	30	63	0.0335		
	40	70	0.0373		
	50	67	0.0357		
Reference Frequency: WCDMA Band II Middle channel=9400 channel=1880.0MHz					
Power supplied (Vdc)	Temperature (°C)	Frequency error		Limit (ppm)	Result
		Hz	ppm		
3.80	-30	31	0.0371	2.5	Pass
	-20	43	0.0515		
	-10	48	0.0580		
	0	23	0.0280		
	10	34	0.0410		
	20	38	0.0449		
	30	55	0.0658		
	40	52	0.0619		
	50	62	0.0736		

Test Result of Voltage Variation

Reference Frequency: GSM850 (GSM link) Middle channel=190 channel=836.6MHz					
Temperature (°C)	Power supplied (Vdc)	Frequency error		Limit (ppm)	Result
		Hz	ppm		
25	3.42	17	0.0205	2.5	Pass
	3.80	19	0.0229		
	4.18	21	0.0254		
Reference Frequency: GSM850 (GPRS 1 link) Middle channel=190 channel=836.6MHz					
Temperature (°C)	Power supplied (Vdc)	Frequency error		Limit (ppm)	Result
		Hz	ppm		
25	3.42	24	0.0283	2.5	Pass
	3.80	15	0.0183		
	4.18	18	0.0216		
Reference Frequency: GSM850 (EGPRS 1 link) Middle channel=190 channel=836.6MHz					
Temperature (°C)	Power supplied (Vdc)	Frequency error		Limit (ppm)	Result
		Hz	ppm		
25	3.42	31	0.0371	2.5	Pass
	3.80	36	0.0430		
	4.18	41	0.0487		

Reference Frequency: PCS1900 (GSM link) Middle channel=661 channel=1880MHz					
Temperature (°C)	Power supplied (Vdc)	Frequency error		Limit (ppm)	Result
		Hz	ppm		
25	3.42	46	0.0244	2.5	Pass
	3.80	56	0.0298		
	4.18	56	0.0298		
Reference Frequency: PCS1900 (GPRS 1 link) Middle channel=661 channel=1880MHz					
Temperature (°C)	Power supplied (Vdc)	Frequency error		Limit (ppm)	Result
		Hz	ppm		
25	3.42	40	0.0215	2.5	Pass
	3.80	32	0.0171		
	4.18	34	0.0180		

Reference Frequency: WCDMA Band V Middle channel=4183 channel=836.6MHz					
Temperature (°C)	Power supplied (Vdc)	Frequency error		Limit (ppm)	Result
		Hz	ppm		
25	3.42	57	0.0304	2.5	Pass
	3.80	48	0.0254		
	4.18	53	0.0283		
Reference Frequency: WCDMA Band II Middle channel=940 channel=1880.0MHz					
Temperature (°C)	Power supplied (Vdc)	Frequency error		Limit (ppm)	Result
		Hz	ppm		
25	3.42	35	0.0420	2.5	Pass
	3.80	45	0.0540		
	4.18	25	0.0299		

7. Photographs of Test Configuration

Radiated Emission

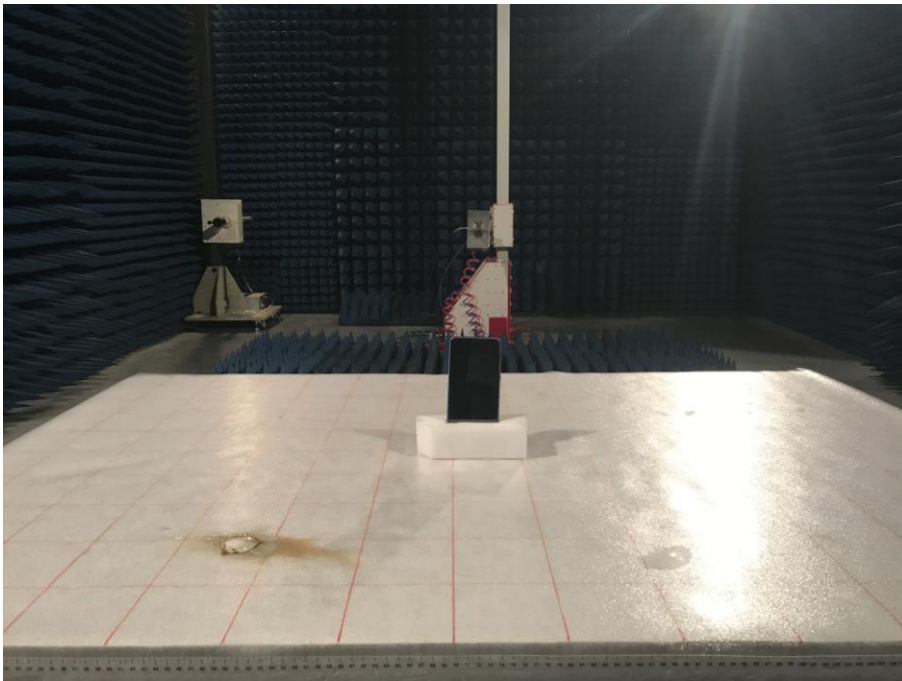
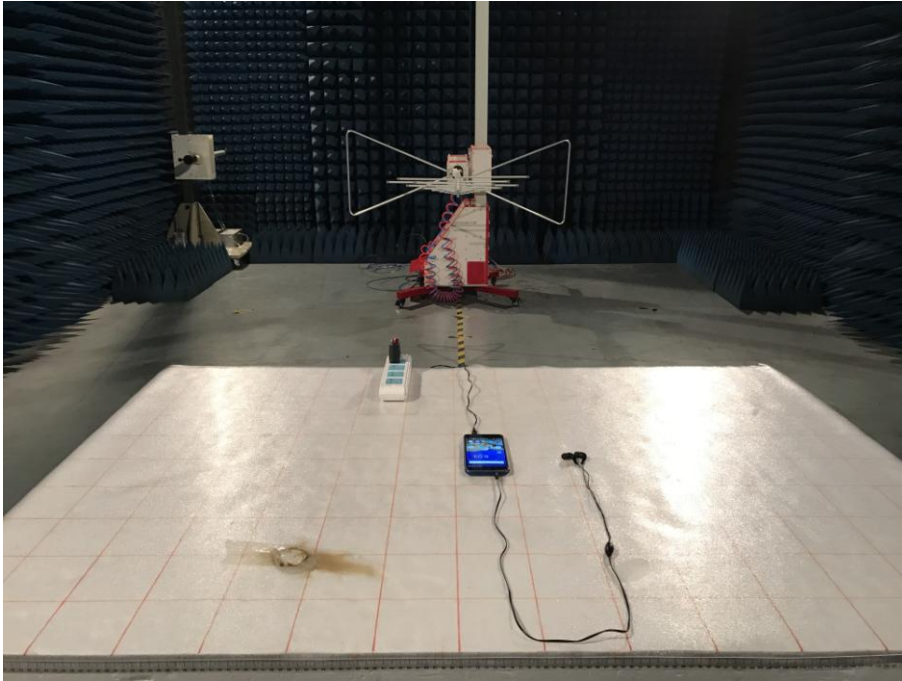

8. Photographs of EUT

Refer to the test report No. TCT171110E013