



## FCC 47 CFR PART 15 SUBPART C

### RF Test Report

Applicant : SHENZHEN OPURES TECHNOLOGY CO., LTD  
Product Type : Wi-Fi Smart Audio System  
Trade Name : OPURES  
Model Number : OP1200,OP1100,OP1210,OP1220  
Applicable Standard : FCC 47 CFR PART 15 SUBPART C  
ANSI C63.10:2013  
Receive Date : Aug. 16, 2016  
Test Period : Aug. 24 ~ Sep. 08, 2016  
Issue Date : Nov. 02, 2016

#### Issue by

A Test Lab Techno Corp.  
No. 140-1, Changan Street, Bade District,  
Taoyuan City 33465, Taiwan (R.O.C)  
Tel : +886-3-2710188 / Fax : +886-3-2710190



Taiwan Accreditation Foundation accreditation number: 1330

**Note:** This report shall not be reproduced except in full, without the written approval of A Test Lab Techno Corp. This document may be altered or revised by A Test Lab Techno Corp. personnel only, and shall be noted in the revision section of the document. The client should not use it to claim product endorsement by TAF, or any government agencies. The test results in the report only apply to the tested sample.



### **Revision History**

Rev.	Issue Date	Revisions	Revised By
00	Sep. 21, 2016	Initial Issue	Tiffany Lee
01	Nov. 02, 2016	Revised report information.	Joyce Liao

## Verification of Compliance

Issued Date: Nov. 02, 2016

Applicant : SHENZHEN OPURES TECHNOLOGY CO., LTD  
Product Type : Wi-Fi Smart Audio System  
Trade Name : OPURES  
Model Number : OP1200,OP1100,OP1210,OP1220  
FCC ID : 2AIFX-OP1200  
EUT Rated Voltage : DC 12V, 2A  
Test Voltage : 120 Vac / 60 Hz  
Applicable Standard : FCC 47 CFR PART 15 SUBPART C  
ANSI C63.10:2013  
Test Result : Complied  
Performing Lab. : A Test Lab Techno Corp.

No. 140-1, Changan Street, Bade District,  
Taoyuan City 33465, Taiwan (R.O.C)

Tel : +886-3-2710188 / Fax : +886-3-2710190

Taiwan Accreditation Foundation accreditation number: 1330

<http://www.atl-lab.com.tw/e-index.htm>



A Test Lab Techno Corp. tested the above equipment in accordance with the requirements set forth in the above standards. All indications of Pass/Fail in this report are opinions expressed by A Test Lab Techno Corp. based on interpretations and/or observations of test results. Measurement Uncertainties were not taken into account and are published for informational purposes only. The test results show that the equipment tested is capable of demonstrating compliance with the requirements as documented in this report.

Approved By

Fly Lu

(Manager)

(Fly Lu)

Reviewed By

Eric Ou Yang

(Testing Engineer)

(Eric Ou Yang)



## TABLE OF CONTENTS

<b>1</b>	<b>General Information .....</b>	<b>6</b>
<b>2</b>	<b>EUT Description.....</b>	<b>7</b>
<b>3</b>	<b>Test Methodology.....</b>	<b>8</b>
	3.1. Mode of Operation.....	8
	3.2. EUT Exercise Software .....	12
	3.3. Configuration of Test System Details.....	13
	3.4. Test Site Environment.....	13
<b>4</b>	<b>AC Power Line Conducted Emission Measurement.....</b>	<b>14</b>
	4.1. Limit.....	14
	4.2. Test Instruments .....	14
	4.3. Test Setup .....	14
	4.4. Test Procedure .....	15
	4.5. Test Result.....	16
<b>5</b>	<b>Radiated Emission Measurement .....</b>	<b>18</b>
	5.1. Limit.....	18
	5.2. Test Instruments .....	18
	5.3. Setup.....	19
	5.4. Test Procedure .....	21
	5.5. Test Result.....	23
<b>6</b>	<b>Maximum Conducted Output Power Measurement.....</b>	<b>34</b>
	6.1. Limit.....	34
	6.2. Test Setup .....	34
	6.3. Test Instruments .....	34
	6.4. Test Procedure .....	34
	6.5. Test Result.....	35
<b>7</b>	<b>6dB RF Bandwidth Measurement.....</b>	<b>41</b>
	7.1. Limit.....	41
	7.2. Test Setup .....	41
	7.3. Test Instruments .....	41
	7.4. Test Procedure .....	41
	7.5. Test Result.....	42
	7.6. Test Graphs .....	43



<b>8</b>	<b>Maximum Power Density Measurement</b>	<b>51</b>
8.1.	Limit	51
8.2.	Test Setup	51
8.3.	Test Instruments	51
8.4.	Test Procedure	51
8.5.	Test Result	52
8.6.	Test Graphs	53
<b>9</b>	<b>Out of Band Conducted Emissions Measurement</b>	<b>61</b>
9.1.	Limit	61
9.2.	Test Setup	61
9.3.	Test Instruments	61
9.4.	Test Procedure	61
9.5.	Test Graphs	62
<b>10</b>	<b>Antenna Measurement</b>	<b>86</b>
10.1.	Limit	86
10.2.	Antenna Description	86
10.3.	Directional Gain Calculated	86



# 1 General Information

## 1.1 Summary of Test Result

Standard	Item	Result	Remark
15.247			
15.207	AC Power Conducted Emission	PASS	-----
Standard	Item	Result	Remark
15.247			
15.247(d)	Transmitter Radiated Emissions	PASS	-----
15.247(b)(3)	Max. Output Power	PASS	-----
15.247(a)(2)	6dB RF Bandwidth	PASS	-----
15.247(e)	Power Spectral Density	PASS	-----
15.247(d)	Out of Band Conducted Spurious Emission	PASS	-----
15.203	Antenna Requirement	PASS	-----

The test results of this report relate only to the tested sample(s) identified in this report. Manufacturer or whom it may concern should recognize the pass or fail of the test result.

## 1.2 Measurement Uncertainty

Test Item	Frequency Range	Uncertainty (dB)
Conducted Emission	9kHz ~ 150KHz	2.7
	150kHz ~ 30MHz	2.8
Radiated Emission	9kHz ~ 30MHz	1.457
	30MHz ~ 1000MHz	6.300
	1000MHz ~ 18000MHz	5.474
	18000MHz ~ 26500MHz	5.630
	26500MHz ~ 40000MHz	5.054
Conducted Output Power	+0.27 dB / -0.28 dB	
RF Bandwidth	4.96%	
Power Spectral Density	+0.71 dB / -0.77 dB	



## 2 EUT Description

Applicant	SHENZHEN OPURES TECHNOLOGY CO., LTD Room 807,the Changsheng Building,huaqiangbei road,Huaqiangbei street,Futian District,Shenzhen city,China			
Manufacturer	SHENZHEN OPURES TECHNOLOGY CO., LTD Room 807,the Changsheng Building,huaqiangbei road,Huaqiangbei street,Futian District,Shenzhen city,China			
Product Type	Wi-Fi Smart Audio System			
Trade Name	OPURES			
Model Number	OP1200,OP1100,OP1210,OP1220			
FCC ID	2AIFX-OP1200			
Operate Freq. Band	Frequency Range (MHz)	Modulation	Channel Bandwidth	Data Rate 400 / 800 GI (ns)
IEEE 802.11b	2412 ~ 2462	DSSS	20MHz	Up to 11Mbps
IEEE 802.11g link mode	2412 ~ 2462	OFDM (64QAM)	20MHz	Up to 54Mbps
IEEE 802.11n 2.4GHz 20MHz	2412 ~ 2462	OFDM	20MHz	Up to 144.4Mbps
IEEE 802.11n 2.4GHz 40MHz	2422 ~ 2452	OFDM	40MHz	Up to 300Mbps
Antenna information	Type		Max. Gain (dBi)	
	PCB Antenna		2	
Antenna Delivery	See section 3.1			

Frequency Band	Max. RF Output Power (W)
IEEE 802.11b	0.083
IEEE 802.11g	0.232
IEEE 802.11n 2.4GHz 20MHz	0.219
IEEE 802.11n 2.4GHz 40MHz	0.182

### 3 Test Methodology

#### 3.1. Mode of Operation

Decision of Test ATL has verified the construction and function in typical operation. All the test modes were carried out with the EUT in normal operation, which was shown in this test report and defined as:

Test Mode
Mode 1: Continuous TX mode
Mode 2: IEEE 802.11b link mode
Mode 3: IEEE 802.11g link mode
Mode 4: IEEE 802.11n 2.4GHz 20MHz link mode
Mode 5: IEEE 802.11n 2.4GHz 40MHz link mode

Software used to control the EUT for staying in continuous transmitting mode was programmed.

After verification, all tests were carried out with the worst case test modes as shown below except radiated spurious emission below 1GHz and power line conducted emissions below 30MHz, which worst case was in normal only.

By preliminary testing and verifying three axis (X, Y and Z) position of EUT transmitted status, it was found that "X axis" position was the worst, then the final test was executed the worst condition and test data were recorded in this report.

Test Mode	ANT-0	ANT-1	ANT-0+1
Mode 2: IEEE 802.11b link mode	V	V	V
Mode 3: IEEE 802.11g link mode	V	V	V
Mode 4: IEEE 802.11n 2.4GHz 20MHz link mode	V	V	V
Mode 5: IEEE 802.11n 2.4GHz 40MHz link mode	V	V	V

Test Mode	Antenna Delivery	Test Channel	Data Rate (Mbps)
Mode 2: IEEE 802.11b link mode	2TX / 2RX (MIMO)	1, 6, 11	1
Mode 3: IEEE 802.11g link mode	2TX / 2RX (MIMO)	1, 6, 11	6
Mode 4: IEEE 802.11n 2.4GHz 20MHz link mode	2TX / 2RX (MIMO)	1, 6, 11	13
Mode 5: IEEE 802.11n 2.4GHz 40MHz link mode	2TX / 2RX (MIMO)	3, 6, 9	27

#### Duty cycle

Test Mode	Frequency (MHz)	on time (ms)	on+off time (ms)	Duty cycle	Duty Factor (dB)	1/T Minimum VBW (kHz)
Mode 2: IEEE 802.11b link mode	2412.0	8.460	8.680	0.975	0.111	0.118
Mode 3: IEEE 802.11g link mode	2412.0	1.405	1.575	0.892	0.496	0.712
Mode 4: IEEE 802.11n 2.4GHz 20MHz link mode	2412.0	1.320	1.515	0.871	0.598	0.758
Mode 5: IEEE 802.11n 2.4GHz 40MHz link mode	2422.0	0.660	0.935	0.706	1.513	1.515





### Duty Cycle Graphs

Mode 2: IEEE 802.11b link mode

On time

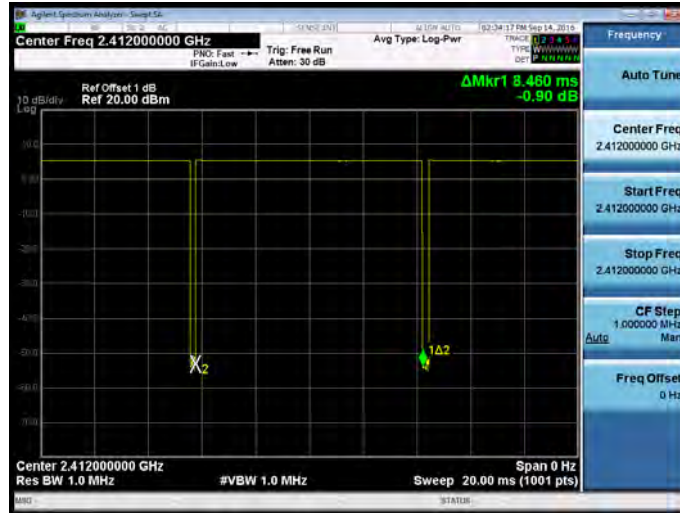

On+off time

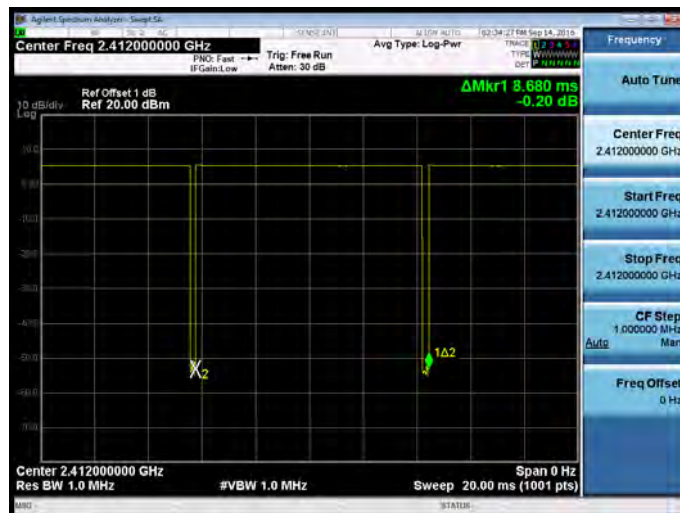



Mode 3: IEEE 802.11g link mode Mode

On time

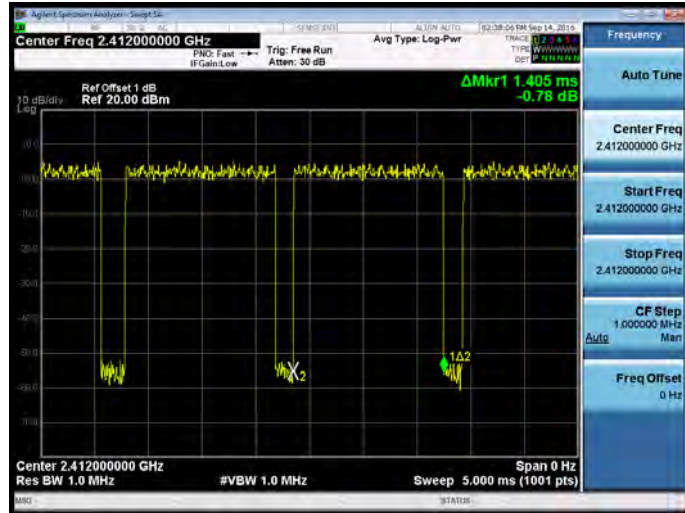

On+off time

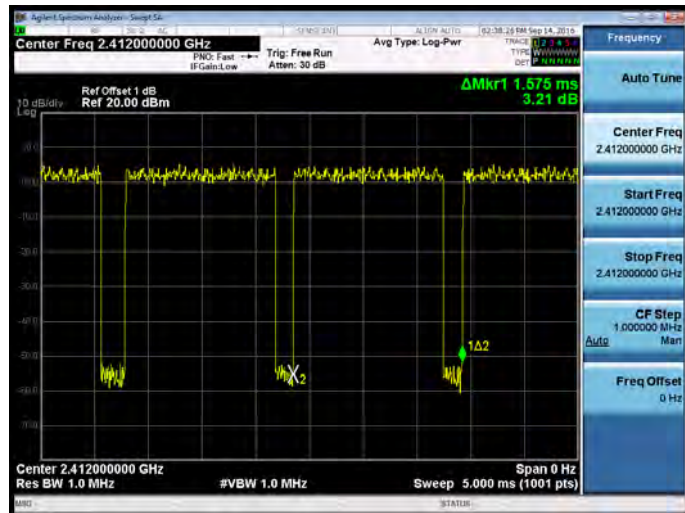



Mode 4: IEEE 802.11n 2.4GHz 20MHz link modeMode

On time

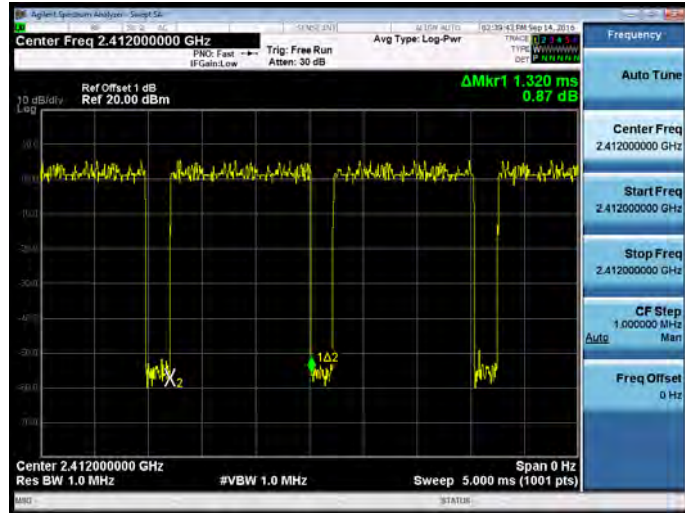

On+off time

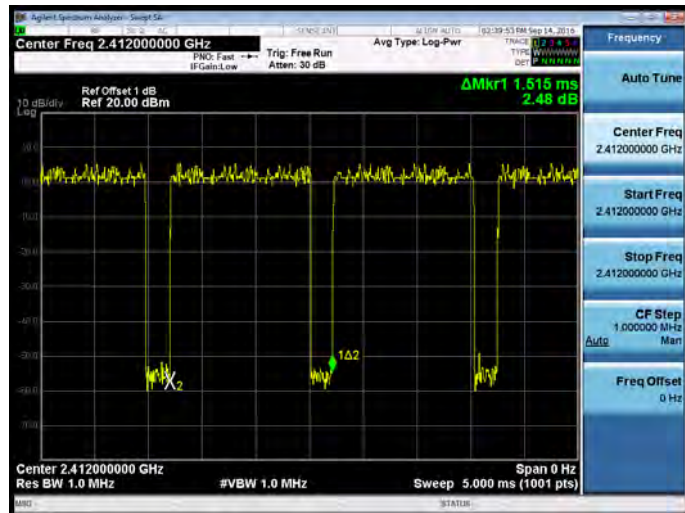

Mode 5: IEEE 802.11n 2.4GHz 40MHz link modeMode	
On time	
On+off time	

### 3.2. EUT Exercise Software

1.	Setup the EUT shown on 3.3.
2.	Turn on the power of all equipment.
3.	Turn Wi-Fi function link to AP
4.	EUT run test program.

Measurement Software	
1	EZ-EMC Ver. ATL-03A1-1
2	EZ-EMC Ver ATL-ITC-3A1-1

### 3.3. Configuration of Test System Details

#### Conducted Emissions

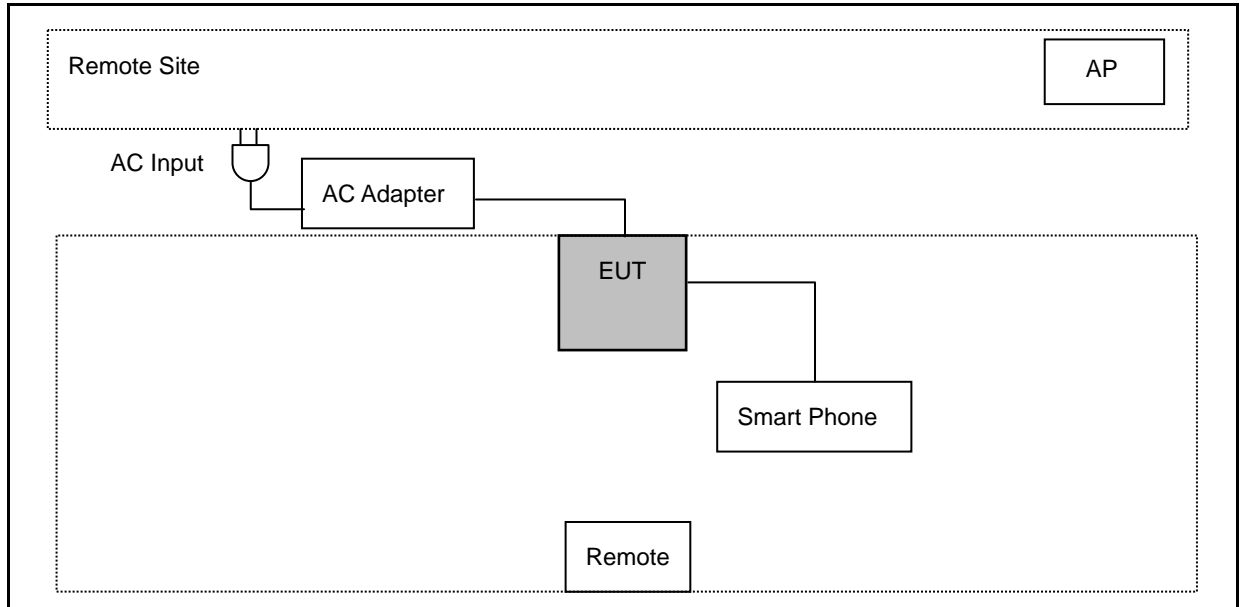

#### Radiated Emissions

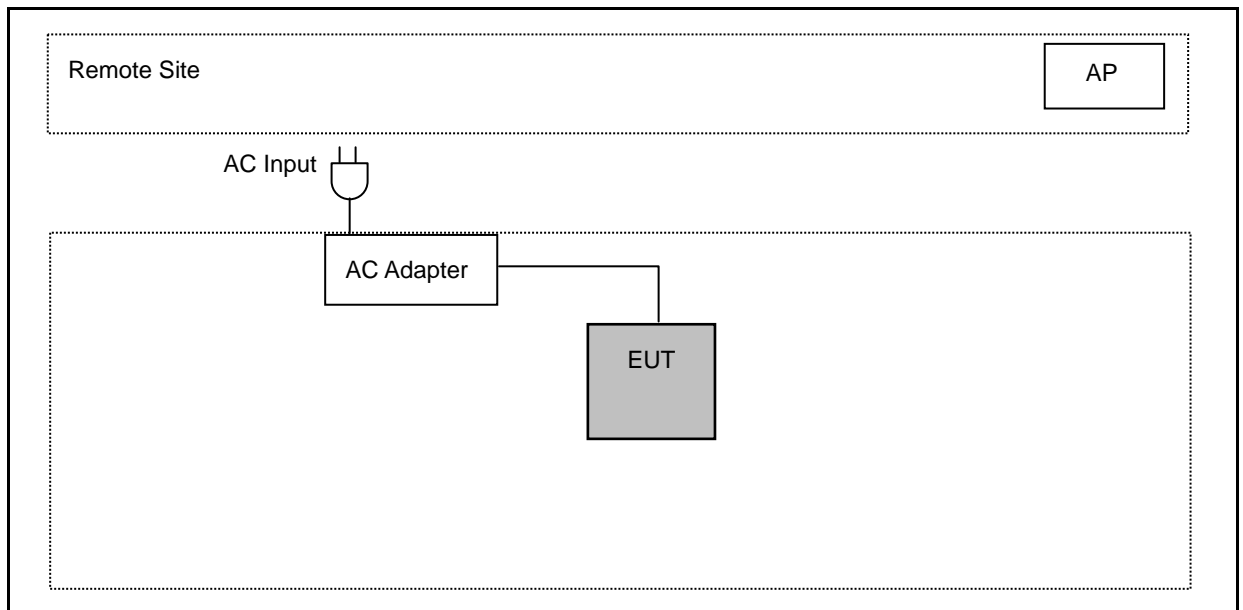

### 3.4. Test Site Environment

Items	Required (IEC 60068-1)	Actual
Temperature (°C)	15-35	26
Humidity (%RH)	25-75	60
Barometric pressure (mbar)	860-1060	950

## 4 AC Power Line Conducted Emission Measurement

### 4.1. Limit

Frequency (MHz)	Quasi-peak	Average
0.15 - 0.5	66 to 56	56 to 46
0.50 - 5.0	56	46
5.0 - 30.0	60	50

### 4.2. Test Instruments

Describe	Manufacturer	Model Number	Serial Number	Cal. Date	Cal. Period
Test Receiver	R&S	ESCI	100367	05/31/2016	1 year
LISN	R&S	ENV216	101040	03/15/2016	1 year
LISN	R&S	ENV216	101041	03/07/2016	1 year
RF Cable	Woken	00100D1380194M	TE-02-02	05/31/2016	1 year
Test Site	ATL	TE02	TE02	N.C.R.	-----

Note: N.C.R. = No Calibration Request.

### 4.3. Test Setup

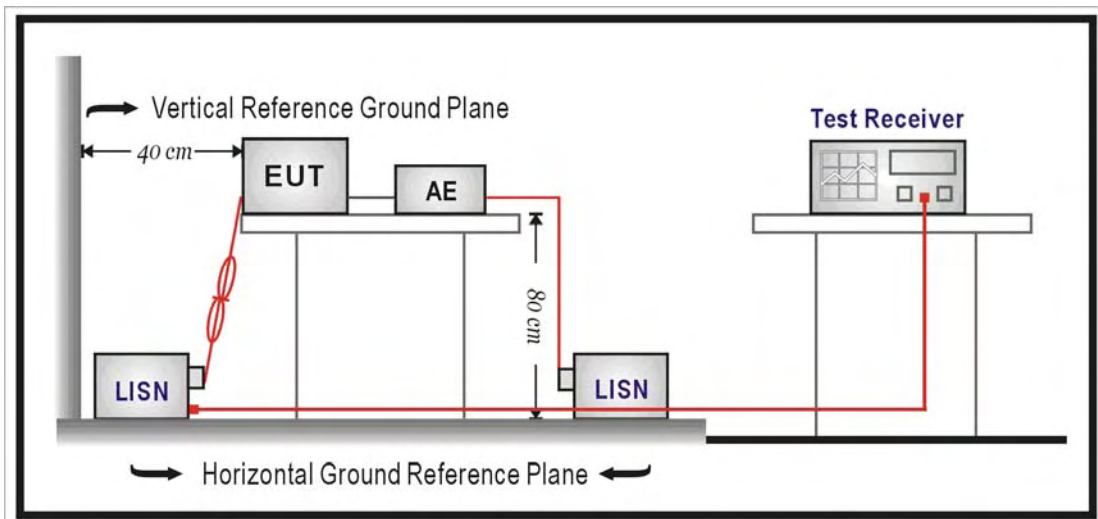

#### 4.4. Test Procedure

The EUT and simulators are connected to the main power through a line impedance stabilization network (L.I.S.N.). This provides a  $50\Omega//50\mu\text{H}$  coupling impedance for the measuring equipment. The peripheral devices are also connected to the main power through a LISN that provides a  $50\Omega//50\mu\text{H}$  coupling impedance with 50ohm termination.

Tabletop device shall be placed on a non-conducting platform, of nominal size 1 m by 1.5 m, raised 80 cm above the reference ground plane. The wall of screened room shall be located 40cm to the rear of the EUT. Other surfaces of tabletop or floor standing EUT shall be at least 80cm from any other ground conducting surface including one or more LISNs. For floor-standing device shall be placed under the EUT with a 12mm insulating material.

Conducted emissions were investigated over the frequency range from 0.15 MHz to 30 MHz using a resolution bandwidth of 9 kHz. The equipment under test (EUT) shall be meet the limits in section 4.1, as applicable, including the average limit and the quasi-peak limit when using respectively, an average detector and quasi-peak detector measured in accordance with the methods described of related standard. When all of peak value were complied with quasi-peak and average limit from 150kHz to 30MHz then quasi-peak and average measurement was unnecessary.

The AMN shall be placed 0,8 m from the boundary of the unit under test and bonded to a ground reference plane for AMNs mounted on top of the ground reference plane. This distance is between the closest points of the AMN and the EUT. All other units of the EUT and associated equipment shall be at least 0,8 m from the AMN. If the mains power cable is longer than 1m then the cable shall be folded back and forth at the centre of the lead to form a bundle no longer than 0.4m. All of interconnecting cables that hang closer than 40cm to the ground plane shall be folded back and forth in the center forming a bundle 30 cm to 40 cm long. All of EUT and AE shall be separate place more than 0.1m. All 50  $\Omega$  ports of the LISN shall be resistively terminated into 50  $\Omega$  loads when not connected to the measuring instrument.

If the reading of the measuring receiver shows fluctuations close to the limit, the reading shall be observed for at least 15 s at each measurement frequency; the higher reading shall be recorded with the exception of any brief isolated high reading which shall be ignored.



### 4.5. Test Result

Standard:	FCC Part 15C	Line:	L1
Test item:	Conducted Emission	Power:	AC 120V/60Hz
Model Number:	OP1200	Temp.(°C)/Hum.(%RH):	26(°C)/60%RH
Mode:	Mode 1	Date:	08/24/2016
		Test By:	Eric Ou Yang
Description:			

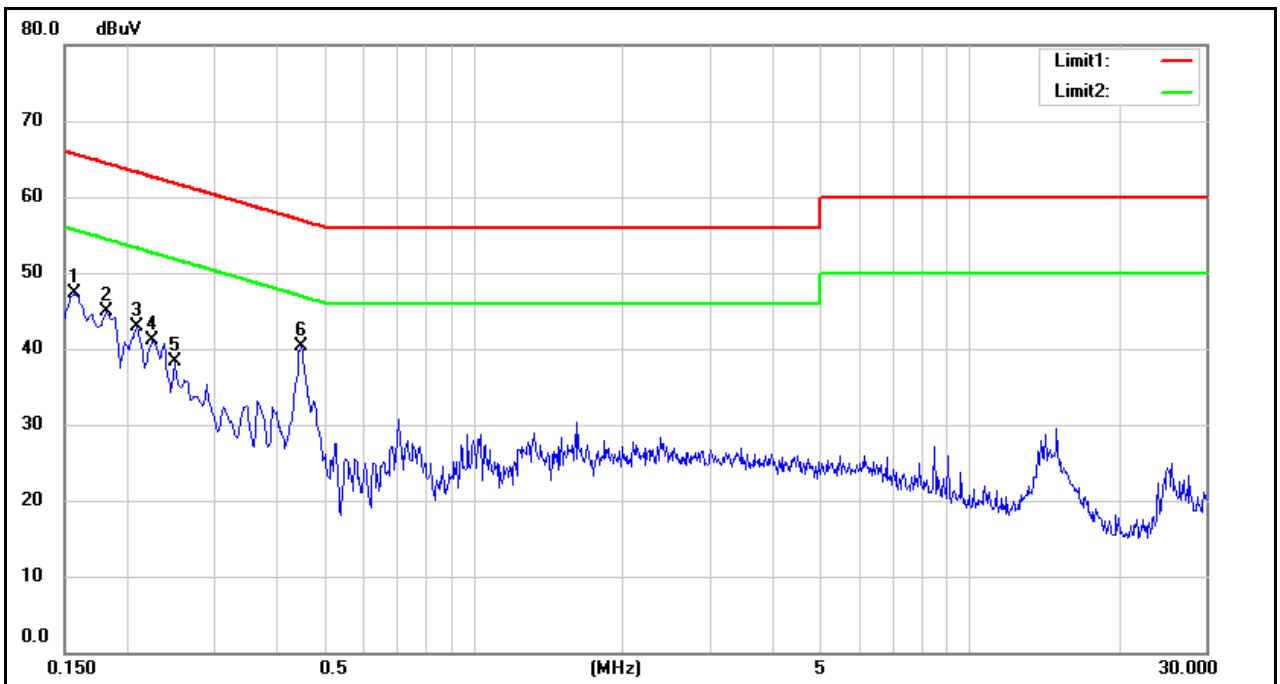

No.	Frequency (MHz)	QP reading (dBuV)	AVG reading (dBuV)	Correction factor (dB)	QP result (dBuV)	AVG result (dBuV)	QP limit (dBuV)	AVG limit (dBuV)	QP margin (dB)	AVG margin (dB)	Remark
1	0.1580	33.77	18.43	10.29	44.06	28.72	65.57	55.57	-21.51	-26.85	Pass
2	0.1820	31.25	17.39	10.27	41.52	27.66	64.39	54.39	-22.87	-26.73	Pass
3	0.2100	28.77	14.45	10.27	39.04	24.72	63.21	53.21	-24.17	-28.49	Pass
4	0.2260	24.45	9.53	10.28	34.73	19.81	62.60	52.60	-27.87	-32.79	Pass
5	0.2500	21.19	5.59	10.30	31.49	15.89	61.76	51.76	-30.27	-35.87	Pass
6	0.4500	27.71	19.20	10.35	38.06	29.55	56.88	46.88	-18.82	-17.33	Pass

Note: 1. Result (dBuV) = Correction factor (dB) + Reading(dBuV).

2. Correction factor (dB) = Cable loss (dB) + L.I.S.N. factor (dB).





Standard:	FCC Part 15C	Line:	N
Test item:	Conducted Emission	Power:	AC 120V/60Hz
Model Number:	OP1200	Temp.(°C)/Hum.(%RH):	26(°C)/60%RH
Mode:	Mode 1	Date:	08/24/2016
		Test By:	Eric Ou Yang
Description:			

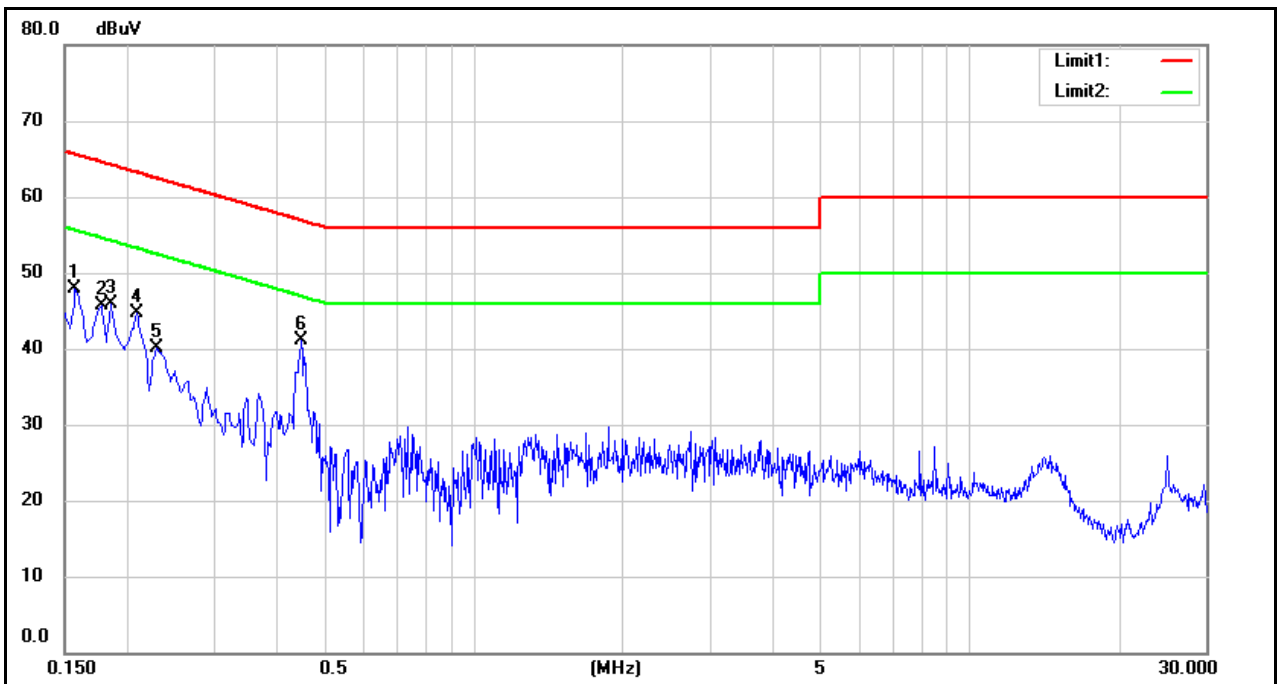

No.	Frequency (MHz)	QP reading (dBuV)	AVG reading (dBuV)	Correction factor (dB)	QP result (dBuV)	AVG result (dBuV)	QP limit (dBuV)	AVG limit (dBuV)	QP margin (dB)	AVG margin (dB)	Remark
1	0.1580	33.88	15.39	10.29	44.17	25.68	65.57	55.57	-21.40	-29.89	Pass
2	0.1780	30.41	12.87	10.27	40.68	23.14	64.58	54.58	-23.90	-31.44	Pass
3	0.1860	31.17	12.93	10.27	41.44	23.20	64.21	54.21	-22.77	-31.01	Pass
4	0.2100	29.39	11.73	10.27	39.66	22.00	63.21	53.21	-23.55	-31.21	Pass
5	0.2300	24.61	7.69	10.29	34.90	17.98	62.45	52.45	-27.55	-34.47	Pass
6	0.4500	26.79	14.63	10.35	37.14	24.98	56.88	46.88	-19.74	-21.90	Pass

Note: 1. Result (dBuV) = Correction factor (dB) + Reading(dBuV).

2. Correction factor (dB) = Cable loss (dB) + L.I.S.N. factor (dB).



## 5 Radiated Emission Measurement

### 5.1. Limit

According to §15.209(a), except as provided elsewhere in this subpart, the emissions from an intentional radiator shall not exceed the field strength levels specified in the following table:

Frequency (MHz)	Field Strength ( $\mu\text{V}/\text{m}$ at meter)	Measurement Distance (meters)
0.009 – 0.490	2400 / F (kHz)	300
0.490 – 1.705	24000 / F (kHz)	30
1.705 – 30.0	30	30
30 - 88	100**	3
88-216	150**	3
216-960	200**	3
Above 960	500	3

\*\* Except as provided in paragraph (g), fundamental emissions from intentional radiators operating under this Section shall not be located in the frequency bands 54-72 MHz, 76-88 MHz, 174-216 MHz or 470-806 MHz. However, operation within these frequency bands is permitted under other sections of this Part, e.g., Sections 15.231 and 15.241.

### 5.2. Test Instruments

3 Meter Chamber					
Equipment	Manufacturer	Model Number	Serial Number	Cal. Date	Cal. Period
RF Pre-selector	Agilent	N9039A	MY46520256	01/08/2016	1 year
Spectrum Analyzer	Agilent	E4446A	MY46180578	01/08/2016	1 year
Pre Amplifier	Agilent	8449B	3008A02237	10/07/2015	1 year
Pre Amplifier	Agilent	8447D	2944A11119	01/11/2016	1 year
Broadband Antenna	Schwarzbeck	VULB9168	416	09/25/2015	1 year
Horn Antenna (1~18GHz)	SCHWARZBECK MESS-ELEKTRONIK	BBHA9120D	9120D-550	06/06/2016	1 year
Horn Antenna (18~40GHz)	ETS	3116	86467	09/05/2016	1 year
Loop Antenna	COM-POWER CORPORATION	AL-130	121014	02/01/2016	1 year
Microwave Cable	EMCI	EMC102-KM-KM-14000	151001	10/15/2015	1 year
Microwave Cable	EMCI	EMC-104-SM-SM-14000	140202	10/15/2015	1 year
Microwave Cable	EMCI	EMC104-SM-SM-600	140301	10/15/2015	1 year
Test Site	ATL	TE01	888001	08/27/2016	1 year

Note: N.C.R. = No Calibration Request.

### 5.3. Setup

9kHz ~ 30MHz

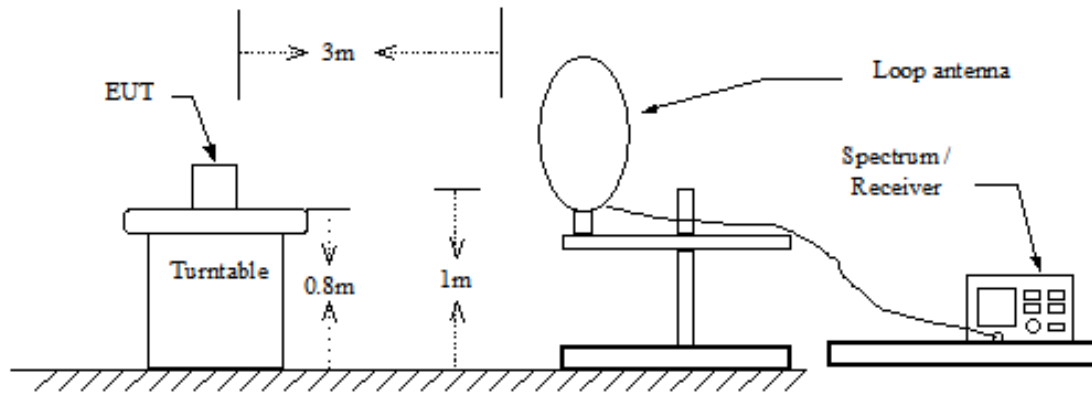

Below 1GHz

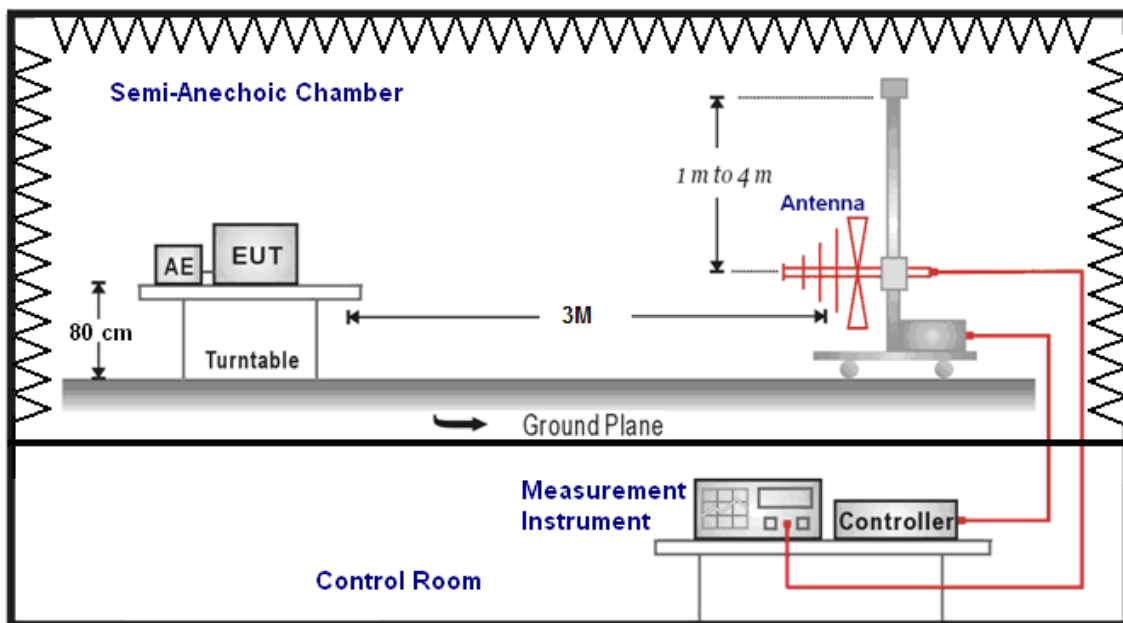



## 5.4. Test Procedure

Final radiation measurements were made on a three-meter, Semi Anechoic Chamber. The EUT system was placed on a nonconductive turntable which is 0.8 meters height, top surface 1.0 x 1.5 meter. The spectrum was examined from 250 MHz to 2.5 GHz in order to cover the whole spectrum below 10th harmonic which could generate from the EUT. During the test, EUT was set to transmit continuously & Measurements spectrum range from 9 kHz to 26.5 GHz is investigated.

For measurements below 1 GHz the resolution bandwidth is set to 100 kHz for peak detection measurements or 120 kHz for quasi-peak detection measurements. Peak detection is used unless otherwise noted as quasi-peak.

For measurements above 1 GHz the resolution bandwidth is set to 1 MHz, and then the video bandwidth is set to 1 MHz for peak measurements and 10 Hz for average measurements when Duty cycle  $>0.98$  /  $1/T$  for average measurements when Duty cycle  $<0.98$ . A nonconductive material surrounded the EUT to supporting the EUT for standing on three orthogonal planes. At each condition, the EUT was rotated 360 degrees, and the antenna was raised and lowered from one to four meters to find the maximum emission levels. Measurements were taken using both horizontal and vertical antenna polarization.

SCHWARZBECK MESS-ELEKTRONIK Biconilog Antenna at 3 Meter and the SCHWARZBECK Double Ridged Guide Antenna was used in frequencies 1 –26.5 GHz at a distance of 3 meter. The antenna at an angle toward the source of the emission. All test results were extrapolated to equivalent signal at 3 meters utilizing an inverse linear distance extrapolation Factor (20dB/decade).

For testing above 1GHz, the emission level of the EUT in peak mode was 20dB lower than average limit (that means the emission level in peak mode also complies with the limit in average mode), then testing will be stopped and peak values of EUT will be reported, otherwise, the emissions will be measured in average mode again and reported.

Appropriate preamplifiers were used for improving sensitivity and precautions were taken to avoid overloading or desensitizing the spectrum analyzer. No post – detector video filters were used in the test.

The spectrum analyzer's 6 dB bandwidth was set to 1 MHz, and the analyzer was operated in the peak detection mode, for frequencies both below and up 1 GHz. The average levels were obtained by subtracting the duty cycle correction factor from the peak readings.

The following procedures were used to convert the emission levels measured in decibels referenced to 1 microvolt (dBuV) into field intensity in micro volts per meter (uV/m).

The actual field intensity in decibels referenced to 1 microvolt in to field intensity in micro volts per meter (dBuV/m).



The actual field intensity in referenced to 1 microvolt per meter (dBuV/m) is determined by algebraically adding the measured reading in dBuV, the antenna factor (dB), and cable loss (dB) and Subtracting the gain of preamplifier (dB) is auto calculate in spectrum analyzer.

(1)  $\text{Amplitude (dBuV/m)} = \text{FI (dBuV)} + \text{AF (dBuV)} + \text{CL (dBuV)} - \text{Gain (dB)}$

FI= Reading of the field intensity.

AF= Antenna factor.

CL= Cable loss.

P.S Amplitude is auto calculate in spectrum analyzer.

(2)  $\text{Actual Amplitude (dBuV/m)} = \text{Amplitude (dBuV)} - \text{Dis(dB)}$

The FCC specified emission limits were calculated according the EUT operating frequency and by following linear interpolation equations:

(a) For fundamental frequency : Transmitter Output < +30dBm

(b) For spurious frequency : Spurious emission limits = fundamental emission limit /10

Data of measurement within this frequency range without mark in the table above means the reading of emissions are attenuated more than 20dB below the permissible limits or the field strength is too small to be measured.



**5.5. Test Result**

**Below 1GHz**

Standard:	FCC Part 15C	Test Distance:	3m
Test item:	Radiated Emission	Power:	AC 120V/60Hz
Model Number:	OP1200	Temp.(°C)/Hum.(%RH):	26(°C)/60%RH
Mode:	Mode 1	Date:	08/25/2016
		Test By:	Eric Ou Yang

Frequency (MHz)	Reading (dBuV)	Correct Factor (dB/m)	Result (dBuV/m)	Limit (dBuV/m)	Margin (dB)	Remark	Ant.Polar. H / V
105.6600	40.68	-15.09	25.59	43.50	-17.91	100	359
154.1600	41.58	-10.98	30.60	43.50	-12.90	100	170
180.3500	42.13	-12.53	29.60	43.50	-13.90	100	182
194.9000	41.00	-14.25	26.75	43.50	-16.75	100	360
384.0500	35.81	-8.33	27.48	46.00	-18.52	200	335
880.6900	30.44	0.42	30.86	46.00	-15.14	100	219
36.7900	40.53	-12.36	28.17	40.00	-11.83	100	146
44.5500	37.37	-11.44	25.93	40.00	-14.07	100	345
103.7200	45.72	-15.44	30.28	43.50	-13.22	161	360
153.8500	51.44	-10.99	40.45	43.50	-3.05	100	360
180.3500	48.61	-12.53	36.08	43.50	-7.42	200	291
194.9000	50.34	-14.25	36.09	43.50	-7.41	100	190

Note:1.Result (dBuV) = Correction factor (dB) + Reading(dBuV).

2. Correction factor (dB/m) = Antenna Factor (dB/m) + Cable loss (dB) – Pre-Amplifier gain (dB).

3.No emission found between lowest internal used/generated frequencies to 30MHz (9 kHz~30MHz).



**Above 1GHz**

Standard:	FCC Part 15C			Test Distance:	3m		
Test item:	Radiated Emission			Power:	AC 120V/60Hz		
Model Number:	OP1200			Temp.(°C)/Hum.(%RH):	26(°C)/60%RH		
Mode:	Mode 2			Date:	09/08/2016		
Frequency:	2412MHz			Test By:	Eric Ou Yang		
Frequency (MHz)	Reading (dBuV)	Correct Factor (dB/m)	Result (dBuV/m)	Limit (dBuV/m)	Margin (dB)	Remark	Ant.Polar. H / V
4824.000	55.95	-3.14	52.81	74.00	-21.19	peak	H
7236.000	49.19	1.57	50.76	74.00	-23.24	peak	H
4824.000	56.70	-3.14	53.56	74.00	-20.44	peak	V
7236.000	53.93	1.57	55.50	74.00	-18.50	peak	V
7236.000	43.80	1.57	45.37	54.00	-8.63	peak	V

Standard:	FCC Part 15C			Test Distance:	3m		
Test item:	Radiated Emission			Power:	AC 120V/60Hz		
Model Number:	OP1200			Temp.(°C)/Hum.(%RH):	26(°C)/60%RH		
Mode:	Mode 2			Date:	09/08/2016		
Frequency:	2437MHz			Test By:	Eric Ou Yang		
Frequency (MHz)	Reading (dBuV)	Correct Factor (dB/m)	Result (dBuV/m)	Limit (dBuV/m)	Margin (dB)	Remark	Ant.Polar. H / V
4874.000	56.17	-3.14	53.03	74.00	-20.97	peak	H
7313.000	48.42	1.68	50.10	74.00	-23.90	peak	H
4874.000	56.34	-3.14	53.20	74.00	-20.80	peak	V
7313.000	51.96	1.68	53.64	74.00	-20.36	peak	V

Note:1.Result (dBuV) = Correction factor (dB) + Reading(dBuV).

2.Correction factor (dB/m) = Antenna Factor (dB/m) + Cable loss (dB) – Pre-Amplifier gain (dB).





Standard:	FCC Part 15C			Test Distance:	3m		
Test item:	Radiated Emission			Power:	AC 120V/60Hz		
Model Number:	OP1200			Temp.(°C)/Hum.(%RH):	26(°C)/60%RH		
Mode:	Mode 2			Date:	09/08/2016		
Frequency:	2462MHz			Test By:	Eric Ou Yang		
Frequency (MHz)	Reading (dBuV)	Correct Factor (dB/m)	Result (dBuV/m)	Limit (dBuV/m)	Margin (dB)	Remark	Ant.Polar. H / V
4924.000	53.43	-3.16	50.27	74.00	-23.73	peak	H
7386.000	47.10	1.84	48.94	74.00	-25.06	peak	H
4924.000	52.57	-3.16	49.41	74.00	-24.59	peak	V
7386.000	49.45	1.84	51.29	74.00	-22.71	peak	V

Standard:	FCC Part 15C			Test Distance:	3m		
Test item:	Radiated Emission			Power:	AC 120V/60Hz		
Model Number:	OP1200			Temp.(°C)/Hum.(%RH):	26(°C)/60%RH		
Mode:	Mode 3			Date:	09/08/2016		
Frequency:	2412MHz			Test By:	Eric Ou Yang		
Frequency (MHz)	Reading (dBuV)	Correct Factor (dB/m)	Result (dBuV/m)	Limit (dBuV/m)	Margin (dB)	Remark	Ant.Polar. H / V
4824.000	50.43	-3.14	47.29	74.00	-26.71	peak	H
7236.000	50.71	1.57	52.28	74.00	-21.72	peak	H
4824.000	51.78	-3.14	48.64	74.00	-25.36	peak	V
7236.000	53.95	1.57	55.52	74.00	-18.48	peak	V
7236.000	41.59	1.57	43.16	54.00	-10.84	peak	V

Note:1.Result (dBuV) = Correction factor (dB) + Reading(dBuV).

2.Correction factor (dB/m) = Antenna Factor (dB/m) + Cable loss (dB) – Pre-Amplifier gain (dB).



Standard:	FCC Part 15C			Test Distance:	3m		
Test item:	Radiated Emission			Power:	AC 120V/60Hz		
Model Number:	OP1200			Temp.(°C)/Hum.(%RH):	26(°C)/60%RH		
Mode:	Mode 3			Date:	09/08/2016		
Frequency:	2437MHz			Test By:	Eric Ou Yang		
Frequency (MHz)	Reading (dBuV)	Correct Factor (dB/m)	Result (dBuV/m)	Limit (dBuV/m)	Margin (dB)	Remark	Ant.Polar. H / V
4874.000	50.73	-3.14	47.59	74.00	-26.41	peak	H
7313.000	47.17	1.68	48.85	74.00	-25.15	peak	H
4874.000	52.33	-3.14	49.19	74.00	-24.81	peak	V
7313.000	50.84	1.68	52.52	74.00	-21.48	peak	V

Standard:	FCC Part 15C			Test Distance:	3m		
Test item:	Radiated Emission			Power:	AC 120V/60Hz		
Model Number:	OP1200			Temp.(°C)/Hum.(%RH):	26(°C)/60%RH		
Mode:	Mode 3			Date:	09/08/2016		
Frequency:	2462MHz			Test By:	Eric Ou Yang		
Frequency (MHz)	Reading (dBuV)	Correct Factor (dB/m)	Result (dBuV/m)	Limit (dBuV/m)	Margin (dB)	Remark	Ant.Polar. H / V
4924.000	50.30	-3.16	47.14	74.00	-26.86	peak	H
7386.000	46.92	1.84	48.76	74.00	-25.24	peak	H
4924.000	50.15	-3.16	46.99	74.00	-27.01	peak	V
7386.000	47.69	1.84	49.53	74.00	-24.47	peak	V

Note:1.Result (dBuV) = Correction factor (dB) + Reading(dBuV).

2.Correction factor (dB/m) = Antenna Factor (dB/m) + Cable loss (dB) – Pre-Amplifier gain (dB).



Standard:	FCC Part 15C	Test Distance:	3m
Test item:	Radiated Emission	Power:	AC 120V/60Hz
Model Number:	OP1200	Temp.(°C)/Hum.(%RH):	26(°C)/60%RH
Mode:	Mode 4	Date:	09/08/2016
Frequency:	2412MHz	Test By:	Eric Ou Yang

Frequency (MHz)	Reading (dBuV)	Correct Factor (dB/m)	Result (dBuV/m)	Limit (dBuV/m)	Margin (dB)	Remark	Ant.Polar. H / V
4824.000	50.89	-3.14	47.75	74.00	-26.25	peak	H
7236.000	48.00	1.57	49.57	74.00	-24.43	peak	H
4824.000	52.49	-3.14	49.35	74.00	-24.65	peak	V
7236.000	49.48	1.57	51.05	74.00	-22.95	peak	V

Standard:	FCC Part 15C	Test Distance:	3m
Test item:	Radiated Emission	Power:	AC 120V/60Hz
Model Number:	OP1200	Temp.(°C)/Hum.(%RH):	26(°C)/60%RH
Mode:	Mode 4	Date:	09/08/2016
Frequency:	2437MHz	Test By:	Eric Ou Yang

Frequency (MHz)	Reading (dBuV)	Correct Factor (dB/m)	Result (dBuV/m)	Limit (dBuV/m)	Margin (dB)	Remark	Ant.Polar. H / V
4874.000	49.88	-3.14	46.74	74.00	-27.26	peak	H
7313.000	48.28	1.68	49.96	74.00	-24.04	peak	H
4874.000	51.17	-3.14	48.03	74.00	-25.97	peak	V
7313.000	48.44	1.68	50.12	74.00	-23.88	peak	V

Note:1.Result (dBuV) = Correction factor (dB) + Reading(dBuV).

2.Correction factor (dB/m) = Antenna Factor (dB/m) + Cable loss (dB) – Pre-Amplifier gain (dB).



Standard: FCC Part 15C		Test Distance: 3m					
Test item: Radiated Emission		Power: AC 120V/60Hz					
Model Number: OP1200		Temp.(°C)/Hum.(%RH): 26(°C)/60%RH					
Mode: Mode 4		Date: 09/08/2016					
Frequency: 2462MHz		Test By: Eric Ou Yang					
Frequency (MHz)	Reading (dBuV)	Correct Factor (dB/m)	Result (dBuV/m)	Limit (dBuV/m)	Margin (dB)	Remark	Ant.Polar. H / V
4924.000	49.07	-3.16	45.91	74.00	-28.09	peak	H
7386.000	46.80	1.84	48.64	74.00	-25.36	peak	H
4924.000	51.02	-3.16	47.86	74.00	-26.14	peak	V
7386.000	47.43	1.84	49.27	74.00	-24.73	peak	V

Standard: FCC Part 15C		Test Distance: 3m					
Test item: Radiated Emission		Power: AC 120V/60Hz					
Model Number: OP1200		Temp.(°C)/Hum.(%RH): 26(°C)/60%RH					
Mode: Mode 5		Date: 09/08/2016					
Frequency: 2422MHz		Test By: Eric Ou Yang					
Frequency (MHz)	Reading (dBuV)	Correct Factor (dB/m)	Result (dBuV/m)	Limit (dBuV/m)	Margin (dB)	Remark	Ant.Polar. H / V
4844.000	49.01	-3.14	45.87	74.00	-28.13	peak	H
7266.000	47.39	1.57	48.96	74.00	-25.04	peak	H
4844.000	49.67	-3.14	46.53	74.00	-27.47	peak	V
7266.000	48.19	1.57	49.76	74.00	-24.24	peak	V

Note:1.Result (dBuV) = Correction factor (dB) + Reading(dBuV).

2.Correction factor (dB/m) = Antenna Factor (dB/m) + Cable loss (dB) – Pre-Amplifier gain (dB).



Standard:		FCC Part 15C		Test Distance:		3m	
Test item:		Radiated Emission		Power:		AC 120V/60Hz	
Model Number:		OP1200		Temp.(°C)/Hum.(%RH):		26(°C)/60%RH	
Mode:		Mode 5		Date:		09/08/2016	
Frequency:		2437MHz		Test By:		Eric Ou Yang	
Frequency (MHz)	Reading (dBuV)	Correct Factor (dB/m)	Result (dBuV/m)	Limit (dBuV/m)	Margin (dB)	Remark	Ant.Polar. H / V
4874.000	49.94	-3.14	46.80	74.00	-27.20	peak	H
7313.000	48.27	1.68	49.95	74.00	-24.05	peak	H
4874.000	49.76	-3.14	46.62	74.00	-27.38	peak	V
7313.000	48.04	1.68	49.72	74.00	-24.28	peak	V

Standard:		FCC Part 15C		Test Distance:		3m	
Test item:		Radiated Emission		Power:		AC 120V/60Hz	
Model Number:		OP1200		Temp.(°C)/Hum.(%RH):		26(°C)/60%RH	
Mode:		Mode 5		Date:		09/08/2016	
Frequency:		2452MHz		Test By:		Eric Ou Yang	
Frequency (MHz)	Reading (dBuV)	Correct Factor (dB/m)	Result (dBuV/m)	Limit (dBuV/m)	Margin (dB)	Remark	Ant.Polar. H / V
4904.000	48.72	-3.16	45.56	74.00	-28.44	peak	H
7356.000	47.96	1.78	49.74	74.00	-24.26	peak	H
4904.000	48.88	-3.16	45.72	74.00	-28.28	peak	V
7356.000	47.72	1.78	49.50	74.00	-24.50	peak	V

Note:1.Result (dBuV) = Correction factor (dB) + Reading(dBuV).

2.Correction factor (dB/m) = Antenna Factor (dB/m) + Cable loss (dB) – Pre-Amplifier gain (dB).



**Band Edge**

Standard:	FCC Part 15C	Test Distance:	3m
Test item:	Radiated Emission	Power:	AC 120V/60Hz
Model Number:	OP1200	Temp.(°C)/Hum.(%RH):	26(°C)/60%RH
Mode:	Mode 2	Date:	09/08/2016
Frequency:	2412 MHz	Test By:	Eric Ou Yang

Frequency (MHz)	Reading (dBuV)	Correct Factor (dB/m)	Result (dBuV/m)	Limit (dBuV/m)	Margin (dB)	Remark	Ant.Polar. H / V
2389.866	62.25	-9.49	52.76	74.00	-21.24	peak	H
2390.000	61.21	-9.49	51.72	74.00	-22.28	AVG	H
2389.050	63.94	-9.49	54.45	74.00	-19.55	peak	V
2389.050	51.27	-9.49	41.78	54.00	-12.22	AVG	V
2390.000	62.48	-9.49	52.99	74.00	-21.01	peak	V

Standard:	FCC Part 15C	Test Distance:	3m
Test item:	Radiated Emission	Power:	AC 120V/60Hz
Model Number:	OP1200	Temp.(°C)/Hum.(%RH):	26(°C)/60%RH
Mode:	Mode 2	Date:	09/08/2016
Frequency:	2462 MHz	Test By:	Eric Ou Yang

Frequency (MHz)	Reading (dBuV)	Correct Factor (dB/m)	Result (dBuV/m)	Limit (dBuV/m)	Margin (dB)	Remark	Ant.Polar. H / V
2483.500	53.61	-9.40	44.21	74.00	-29.79	peak	H
2494.186	55.79	-9.38	46.41	74.00	-27.59	AVG	H
2483.500	55.07	-9.40	45.67	74.00	-28.33	peak	V
2493.806	57.11	-9.38	47.73	74.00	-26.27	AVG	V

Note:1.Result (dBuV) = Correction factor (dB) + Reading(dBuV).

2.Correction factor (dB/m) = Antenna Factor (dB/m) + Cable loss (dB) – Pre-Amplifier gain (dB).



Standard:	FCC Part 15C			Test Distance:	3m		
Test item:	Radiated Emission			Power:	AC 120V/60Hz		
Model Number:	OP1200			Temp.(°C)/Hum.(%RH):	26(°C)/60%RH		
Mode:	Mode 3			Date:	09/08/2016		
Frequency:	2412 MHz			Test By:	Eric Ou Yang		
Frequency (MHz)	Reading (dBuV)	Correct Factor (dB/m)	Result (dBuV/m)	Limit (dBuV/m)	Margin (dB)	Remark	Ant.Polar. H / V
2389.764	60.95	-9.49	51.46	74.00	-22.54	peak	H
2390.000	59.90	-9.49	50.41	74.00	-23.59	peak	H
2390.000	62.71	-9.49	53.22	74.00	-20.78	peak	V

Standard:	FCC Part 15C			Test Distance:	3m		
Test item:	Radiated Emission			Power:	AC 120V/60Hz		
Model Number:	OP1200			Temp.(°C)/Hum.(%RH):	26(°C)/60%RH		
Mode:	Mode 3			Date:	09/08/2016		
Frequency:	2462 MHz			Test By:	Eric Ou Yang		
Frequency (MHz)	Reading (dBuV)	Correct Factor (dB/m)	Result (dBuV/m)	Limit (dBuV/m)	Margin (dB)	Remark	Ant.Polar. H / V
2483.500	57.16	-9.40	47.76	74.00	-26.24	peak	H
2483.812	57.82	-9.40	48.42	74.00	-25.58	peak	H
2483.500	55.94	-9.40	46.54	74.00	-27.46	peak	V
2486.890	60.89	-9.39	51.50	74.00	-22.50	peak	V

Note:1.Result (dBuV) = Correction factor (dB) + Reading(dBuV).

2.Correction factor (dB/m) = Antenna Factor (dB/m) + Cable loss (dB) – Pre-Amplifier gain (dB).



Standard:	FCC Part 15C			Test Distance:	3m		
Test item:	Radiated Emission			Power:	AC 120V/60Hz		
Model Number:	OP1200			Temp.(°C)/Hum.(%RH):	26(°C)/60%RH		
Mode:	Mode 4			Date:	09/08/2016		
Frequency:	2412 MHz			Test By:	Eric Ou Yang		
Frequency (MHz)	Reading (dBuV)	Correct Factor (dB/m)	Result (dBuV/m)	Limit (dBuV/m)	Margin (dB)	Remark	Ant.Polar. H / V
2389.866	62.13	-9.49	52.64	74.00	-21.36	peak	H
2390.000	61.35	-9.49	51.86	74.00	-22.14	AVG	H
2389.254	63.53	-9.49	54.04	74.00	-19.96	peak	V
2389.254	51.65	-9.49	42.16	54.00	-11.84	AVG	V
2390.000	60.35	-9.49	50.86	74.00	-23.14	peak	V

Standard:	FCC Part 15C			Test Distance:	3m		
Test item:	Radiated Emission			Power:	AC 120V/60Hz		
Model Number:	OP1200			Temp.(°C)/Hum.(%RH):	26(°C)/60%RH		
Mode:	Mode 4			Date:	09/08/2016		
Frequency:	2462 MHz			Test By:	Eric Ou Yang		
Frequency (MHz)	Reading (dBuV)	Correct Factor (dB/m)	Result (dBuV/m)	Limit (dBuV/m)	Margin (dB)	Remark	Ant.Polar. H / V
2483.500	56.36	-9.40	46.96	74.00	-27.04	peak	H
2484.002	58.20	-9.40	48.80	74.00	-25.20	peak	H
2483.500	58.73	-9.40	49.33	74.00	-24.67	peak	V
2483.660	60.74	-9.40	51.34	74.00	-22.66	peak	V

Note:1.Result (dBuV) = Correction factor (dB) + Reading(dBuV).

2.Correction factor (dB/m) = Antenna Factor (dB/m) + Cable loss (dB) – Pre-Amplifier gain (dB).





Standard: FCC Part 15C		Test Distance: 3m					
Test item: Radiated Emission		Power: AC 120V/60Hz					
Model Number: OP1200		Temp.(°C)/Hum.(%RH): 26(°C)/60%RH					
Mode: Mode 5		Date: 09/08/2016					
Frequency: 2422 MHz		Test By: Eric Ou Yang					
Frequency (MHz)	Reading (dBuV)	Correct Factor (dB/m)	Result (dBuV/m)	Limit (dBuV/m)	Margin (dB)	Remark	Ant.Polar. H / V
2389.744	61.32	-9.49	51.83	74.00	-22.17	peak	H
2390.000	59.83	-9.49	50.34	74.00	-23.66	peak	H
2389.632	62.63	-9.49	53.14	74.00	-20.86	peak	V
2390.000	61.62	-9.49	52.13	74.00	-21.87	peak	V

Standard: FCC Part 15C		Test Distance: 3m					
Test item: Radiated Emission		Power: AC 120V/60Hz					
Model Number: OP1200		Temp.(°C)/Hum.(%RH): 26(°C)/60%RH					
Mode: Mode 5		Date: 09/08/2016					
Frequency: 2452 MHz		Test By: Eric Ou Yang					
Frequency (MHz)	Reading (dBuV)	Correct Factor (dB/m)	Result (dBuV/m)	Limit (dBuV/m)	Margin (dB)	Remark	Ant.Polar. H / V
2483.500	58.99	-9.40	49.59	74.00	-24.41	peak	H
2485.888	61.97	-9.39	52.58	74.00	-21.42	peak	H
2483.500	64.34	-9.40	54.94	74.00	-19.06	peak	V
2483.500	46.82	-9.40	37.42	54.00	-16.58	AVG	V
2486.032	68.11	-9.39	58.72	74.00	-15.28	peak	V
2486.032	47.98	-9.39	38.59	54.00	-15.41	AVG	V

Note:1.Result (dBuV) = Correction factor (dB) + Reading(dBuV).

2.Correction factor (dB/m) = Antenna Factor (dB/m) + Cable loss (dB) – Pre-Amplifier gain (dB).

## 6 Maximum Conducted Output Power Measurement

### 6.1. Limit

For systems using digital modulation in the 2400-2483.5MHz, the limit for maximum output power is 30dBm.

And According to 15.247 (b), if transmitting antennas of directional gain greater than 6 dBi are used, the power shall be reduced by the amount in dB that the directional gain of the antenna exceeds 6dBi.

\* MIMO mode : Directional Gain =  $G_{ANT} + 10 \cdot \log(N_{ANT}/N_{SS})$

### 6.2. Test Setup

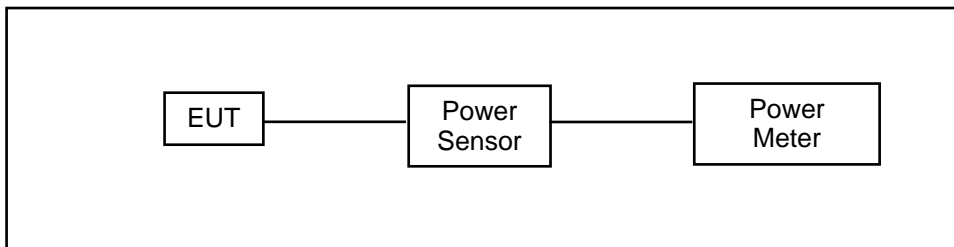

### 6.3. Test Instruments

Equipment	Manufacturer	Model Number	Serial Number	Cal. Date	Cal. Period
Power Sensor	Anritsu	MA2411B	1126022	08/24/2016	1 year
Power Meter	Anritsu	ML2495A	1135009	08/24/2016	1 year
Microwave Cable	EMCI	EMC104-SM-SM-1500	140303	02/23/2016	1 year
Test Site	ATL	TE05	TE05	N.C.R.	-----

Note: N.C.R. = No Calibration Request.

### 6.4. Test Procedure

The tests below are run with the EUT's transmitter set at high power in TX mode. The EUT is needed to force selection of output power level and channel number. While testing, EUT was set to transmit continuously. Remove the Subjective device's antenna and connect the RF output port to power sensor.



### 6.5. Test Result

Model Number	OP1200						
Test Item	Maximum Conducted Output Power						
Date of Test	08/24/2016						
ANT-0							
Test Mode	Frequency (MHz)	Data Rate	Average Output Power		Peak Output Power		
			Measurement Results		Measurement Results		Limit
			dBm	W	dBm	W	dBm
Mode 2	2412	1M	13.57	0.023	15.72	0.037	< 30
	2437		14.09	0.026	<b>16.29</b>	0.043	< 30
	2462		13.91	0.025	16.02	0.040	< 30
	2437	2M	13.94	0.025	16.24	0.042	< 30
	2437	5.5M	13.76	0.024	16.25	0.042	< 30
	2437	11M	13.39	0.022	16.17	0.041	< 30
Mode 3	2412	6M	11.34	0.014	20.68	0.117	< 30
	2437		11.45	0.014	<b>20.72</b>	0.118	< 30
	2462		11.22	0.013	20.46	0.111	< 30
	2437	9M	10.98	0.013	20.59	0.115	< 30
	2437	12M	10.71	0.012	20.53	0.113	< 30
	2437	18M	10.39	0.011	20.47	0.111	< 30
	2437	24M	10.13	0.010	20.49	0.112	< 30
	2437	36M	9.29	0.008	20.21	0.105	< 30
	2437	48M	6.73	0.005	20.04	0.101	< 30
	2437	54M	6.51	0.004	19.92	0.098	< 30

Note: The relevant measured result has the offset with cable loss already.



Model Number	OP1200						
Test Item	Maximum Conducted Output Power						
Date of Test	08/24/2016						
ANT-0							
Test Mode	Frequency (MHz)	Data Rate	Average Output Power		Peak Output Power		
			Measurement Results		Measurement Results		Limit
			dBm	W	dBm	W	dBm
Mode 4	2412	13M	10.78	0.012	20.34	0.108	< 30
	2437		11.12	0.013	<b>20.57</b>	0.114	< 30
	2462		11.08	0.013	20.45	0.111	< 30
	2437	26M	10.52	0.011	20.51	0.112	< 30
	2437	39M	10.11	0.010	20.43	0.110	< 30
	2437	52M	9.78	0.010	20.39	0.109	< 30
	2437	78M	9.35	0.009	20.24	0.106	< 30
	2437	104M	8.62	0.007	20.09	0.102	< 30
	2437	117M	6.53	0.004	19.97	0.099	< 30
	2437	130M	6.25	0.004	19.74	0.094	< 30
Mode 5	2422	27M	9.04	0.008	18.89	0.077	< 30
	2437		9.33	0.009	<b>19.63</b>	0.092	< 30
	2452		9.25	0.008	19.12	0.082	< 30
	2437	54M	8.61	0.007	19.36	0.086	< 30
	2437	81M	7.64	0.006	18.98	0.079	< 30
	2437	108M	7.16	0.005	19.17	0.083	< 30
	2437	162M	6.32	0.004	19.03	0.080	< 30
	2437	216M	5.83	0.004	19.43	0.088	< 30
	2437	243M	3.71	0.002	18.74	0.075	< 30
	2437	270M	3.62	0.002	18.09	0.064	< 30

Note: The relevant measured result has the offset with cable loss already.



Model Number	OP1200						
Test Item	Maximum Conducted Output Power						
Date of Test	08/24/2016						
ANT-1							
Test Mode	Frequency (MHz)	Data Rate	Average Output Power		Peak Output Power		
			Measurement Results		Measurement Results		Limit
			dBm	W	dBm	W	dBm
Mode 2	2412	1M	13.39	0.022	15.51	0.036	< 30
	2437		13.87	0.024	<b>16.08</b>	0.041	< 30
	2462		13.62	0.023	15.83	0.038	< 30
	2437	2M	13.71	0.023	15.91	0.039	< 30
	2437	5.5M	13.49	0.022	15.93	0.039	< 30
	2437	11M	13.13	0.021	15.87	0.039	< 30
Mode 3	2412	6M	10.73	0.012	20.43	0.110	< 30
	2437		11.15	0.013	<b>20.56</b>	0.114	< 30
	2462		10.87	0.012	20.29	0.107	< 30
	2437	9M	10.71	0.012	20.42	0.110	< 30
	2437	12M	10.52	0.011	20.37	0.109	< 30
	2437	18M	10.11	0.010	20.21	0.105	< 30
	2437	24M	9.86	0.010	20.34	0.108	< 30
	2437	36M	9.03	0.008	20.03	0.101	< 30
	2437	48M	6.42	0.004	19.79	0.095	< 30
	2437	54M	6.16	0.004	19.62	0.092	< 30

Note: The relevant measured result has the offset with cable loss already.



Model Number	OP1200						
Test Item	Maximum Conducted Output Power						
Date of Test	08/24/2016						
ANT-1							
Test Mode	Frequency (MHz)	Data Rate	Average Output Power		Peak Output Power		
			Measurement Results		Measurement Results		Limit
			dBm	W	dBm	W	dBm
Mode 4	2412	13M	10.62	0.012	20.07	0.102	< 30
	2437		11.04	0.013	<b>20.23</b>	0.105	< 30
	2462		10.94	0.012	20.17	0.104	< 30
	2437	26M	10.37	0.011	20.17	0.104	< 30
	2437	39M	9.98	0.010	20.09	0.102	< 30
	2437	52M	9.56	0.009	20.03	0.101	< 30
	2437	78M	9.17	0.008	19.94	0.099	< 30
	2437	104M	8.43	0.007	19.87	0.097	< 30
	2437	117M	6.31	0.004	19.78	0.095	< 30
	2437	130M	6.16	0.004	19.64	0.092	< 30
Mode 5	2422	27M	8.61	0.007	18.71	0.074	< 30
	2437		8.95	0.008	<b>19.54</b>	0.090	< 30
	2452		8.83	0.008	18.93	0.078	< 30
	2437	54M	8.34	0.007	19.21	0.083	< 30
	2437	81M	7.31	0.005	18.76	0.075	< 30
	2437	108M	6.95	0.005	19.01	0.080	< 30
	2437	162M	6.11	0.004	18.93	0.078	< 30
	2437	216M	5.47	0.004	18.89	0.077	< 30
	2437	243M	3.14	0.002	18.41	0.069	< 30
	2437	270M	3.02	0.002	17.87	0.061	< 30

Note: The relevant measured result has the offset with cable loss already.



Model Number	OP1200						
Test Item	Maximum Conducted Output Power						
Date of Test	08/24/2016						
ANT-0+1							
Test Mode	Frequency (MHz)	Data Rate	Average Output Power		Peak Output Power		
			Measurement Results		Measurement Results		Limit
			dBm	W	dBm	W	dBm
Mode 2	2412	1M	16.49	0.045	18.63	0.073	< 30
	2437		16.99	0.050	<b>19.20</b>	0.083	< 30
	2462		16.78	0.048	18.94	0.078	< 30
	2437	2M	16.84	0.048	19.09	0.081	< 30
	2437	5.5M	16.64	0.046	19.10	0.081	< 30
	2437	11M	16.27	0.042	19.03	0.080	< 30
Mode 3	2412	6M	14.06	0.025	23.57	0.227	< 30
	2437		14.31	0.027	<b>23.65</b>	0.232	< 30
	2462		14.06	0.025	23.39	0.218	< 30
	2437	9M	13.86	0.024	23.52	0.225	< 30
	2437	12M	13.63	0.023	23.46	0.222	< 30
	2437	18M	13.26	0.021	23.35	0.216	< 30
	2437	24M	13.01	0.020	23.43	0.220	< 30
	2437	36M	12.17	0.016	23.13	0.206	< 30
	2437	48M	9.59	0.009	22.93	0.196	< 30
	2437	54M	9.35	0.009	22.78	0.190	< 30

Note: The relevant measured result has the offset with cable loss already.



Model Number	OP1200						
Test Item	Maximum Conducted Output Power						
Date of Test	08/24/2016						
ANT-0+1							
Test Mode	Frequency (MHz)	Data Rate	Average Output Power		Peak Output Power		
			Measurement Results		Measurement Results		Limit
			dBm	W	dBm	W	dBm
Mode 4	2412	13M	13.71	0.024	23.22	0.210	< 30
	2437		14.09	0.026	<b>23.41</b>	0.219	< 30
	2462		14.02	0.025	23.32	0.215	< 30
	2437	26M	13.46	0.022	23.35	0.216	< 30
	2437	39M	13.06	0.020	23.27	0.213	< 30
	2437	52M	12.68	0.019	23.22	0.210	< 30
	2437	78M	12.27	0.017	23.10	0.204	< 30
	2437	104M	11.54	0.014	22.99	0.199	< 30
	2437	117M	9.43	0.009	22.89	0.194	< 30
	2437	130M	9.22	0.008	22.70	0.186	< 30
Mode 5	2422	27M	11.84	0.015	21.81	0.152	< 30
	2437		12.15	0.016	<b>22.60</b>	0.182	< 30
	2452		12.06	0.016	22.04	0.160	< 30
	2437	54M	11.49	0.014	22.30	0.170	< 30
	2437	81M	10.49	0.011	21.88	0.154	< 30
	2437	108M	10.07	0.010	22.10	0.162	< 30
	2437	162M	9.23	0.008	21.99	0.158	< 30
	2437	216M	8.66	0.007	22.18	0.165	< 30
	2437	243M	6.44	0.004	21.59	0.144	< 30
	2437	270M	6.34	0.004	20.99	0.126	< 30

Note: The relevant measured result has the offset with cable loss already.



## 7 6dB RF Bandwidth Measurement

### 7.1. Limit

6dB RF Bandwidth: Systems using digital modulation techniques may operate in the 2400–2483.5 MHz bands. The minimum 6 dB band-width shall be at least 500 kHz.

### 7.2. Test Setup

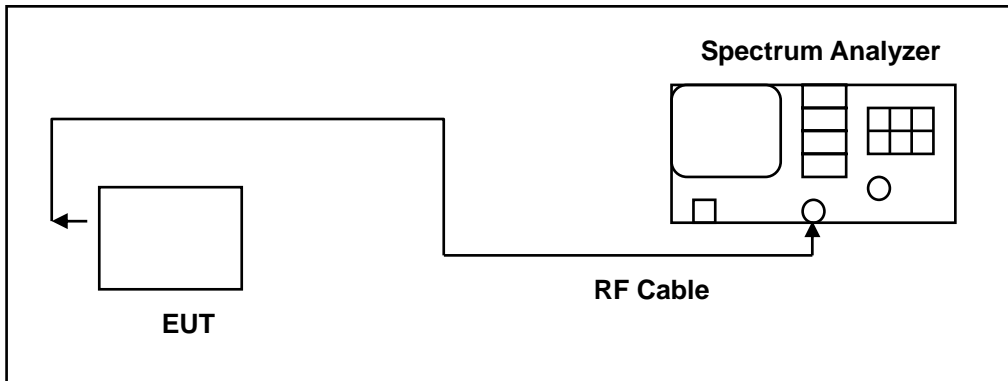

### 7.3. Test Instruments

Equipment	Manufacturer	Model Number	Serial Number	Cal. Date	Cal. Period
Spectrum Analyzer	Agilent	E4445A	MY45300744	12/15/2015	1 year
Microwave Cable	EMCI	EMC104-SM-SM-1500	140303	02/23/2016	1 year
Test Site	ATL	TE05	TE05	N.C.R.	-----

Note: N.C.R. = No Calibration Request.

### 7.4. Test Procedure

The EUT tested to DTS test procedure of KDB558074D01 for compliance to FCC 47CFR 15.247 requirements.

6dB RF Bandwidth: The antenna port of the EUT was connected to the input of a spectrum analyzer. Analyzer RBW was set to 100 kHz. For each RF output channel investigated, the spectrum analyzer center frequency was set to the channel carrier. A peak output reading was taken, a DISPLAY line was drawn 6 dB lower than peak level. The 6 dB bandwidth was determined from where the channel output spectrum intersected the display line.

The test was performed at 3 channels (Channel low, middle, high)



**7.5. Test Result**

Model Number	OP1200			
Test Item	6dB RF Bandwidth			
Date of Test	09/05/2016			
Test Mode	Frequency (MHz)	Measurement (kHz)		Limit (kHz)
		ANT-0	ANT-1	
Mode 2	2412	9573	10000	> 500
	2437	10050	10010	> 500
	2462	10040	9563	> 500
Mode 3	2412	15110	15100	> 500
	2437	15110	15080	> 500
	2462	15100	15110	> 500
Mode 4	2412	15110	15690	> 500
	2437	15090	15100	> 500
	2462	15060	15070	> 500
Mode 5	2422	35080	35060	> 500
	2437	35060	35070	> 500
	2452	35050	35070	> 500



### 7.6. Test Graphs

Mode 2: IEEE 802.11b link mode\_ANT-0

2412 MHz

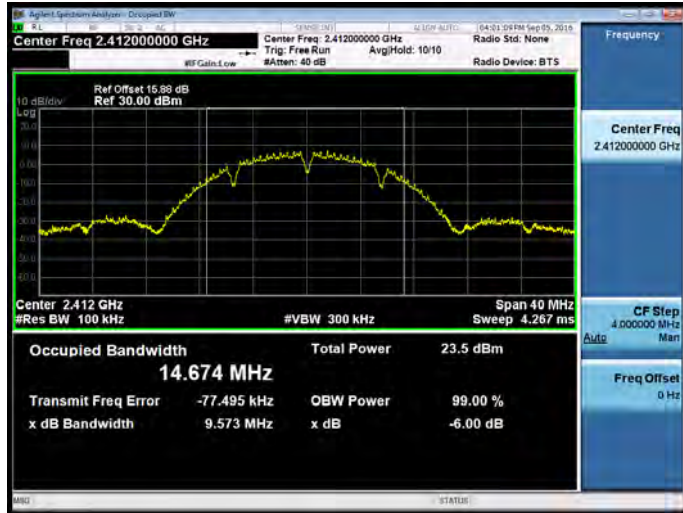

2437 MHz

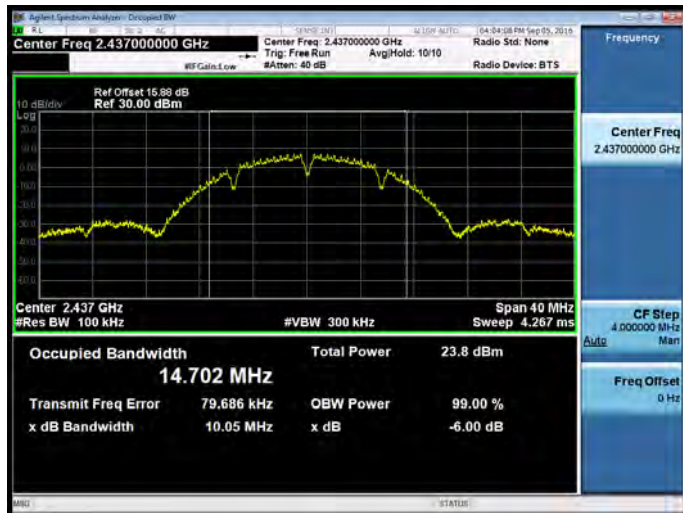

2462 MHz





Mode 3: IEEE 802.11g link mode \_ANT-0

2412 MHz

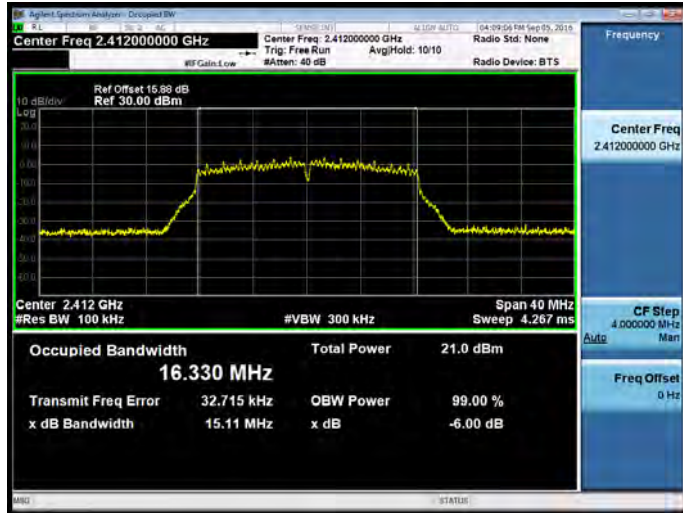

2437 MHz

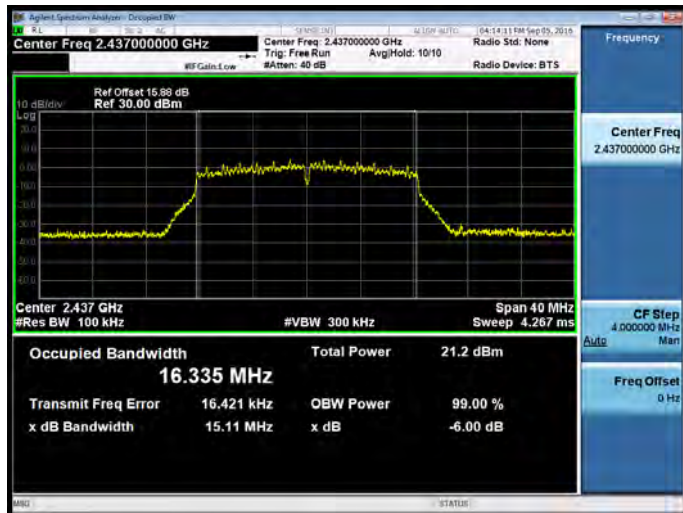

2462 MHz





Mode 4: IEEE 802.11n 2.4GHz 20MHz link mode\_ANT-0

2412 MHz

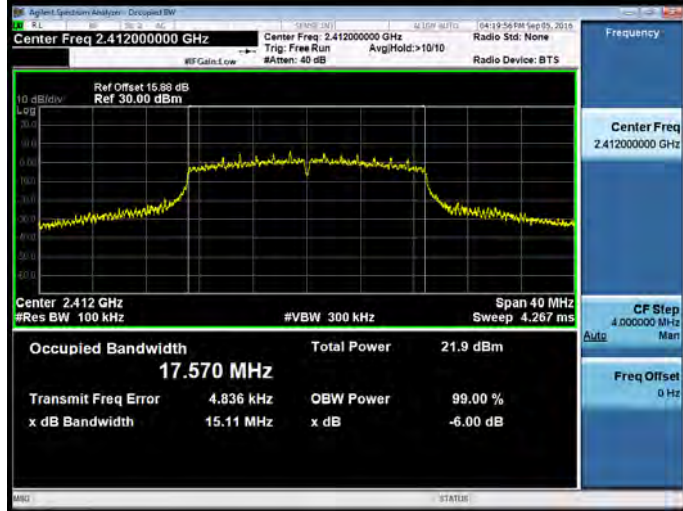

2437 MHz

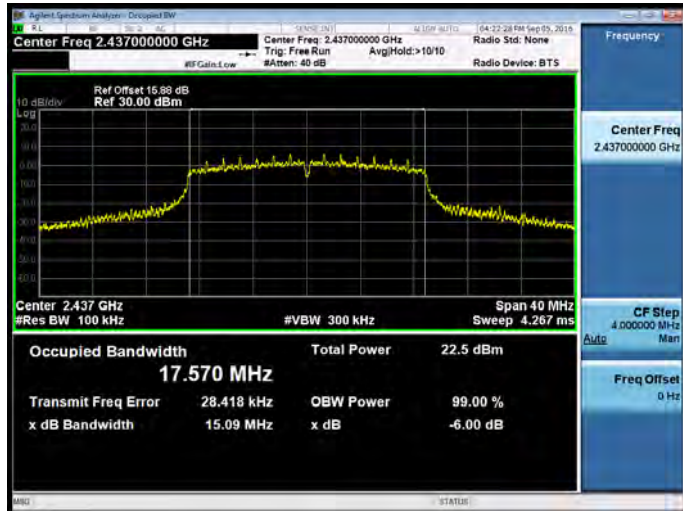

2462 MHz





Mode 5: IEEE 802.11n 2.4GHz 40MHz link mode\_ANT-0

2422 MHz



2437 MHz

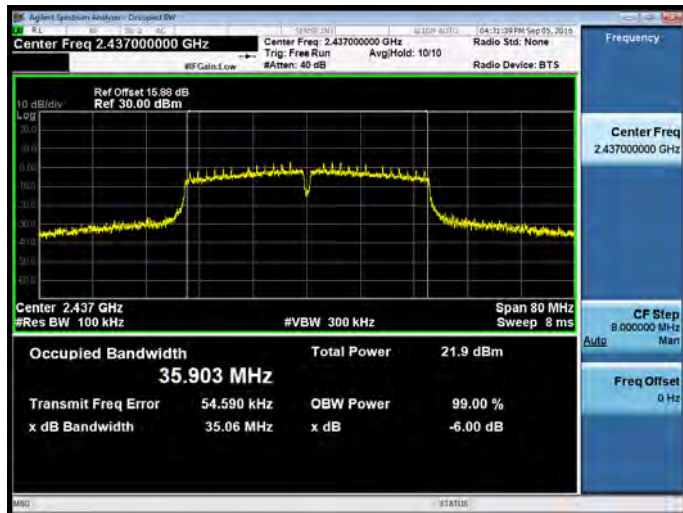

2452 MHz

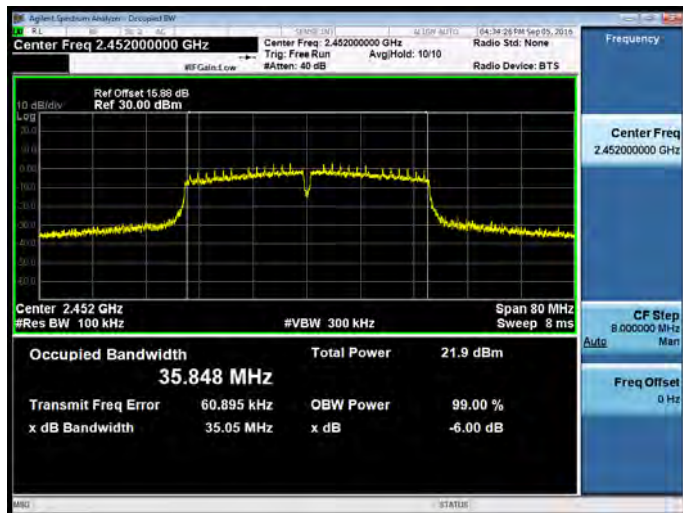



Mode 2: IEEE 802.11b link mode\_ANT-1

2412 MHz

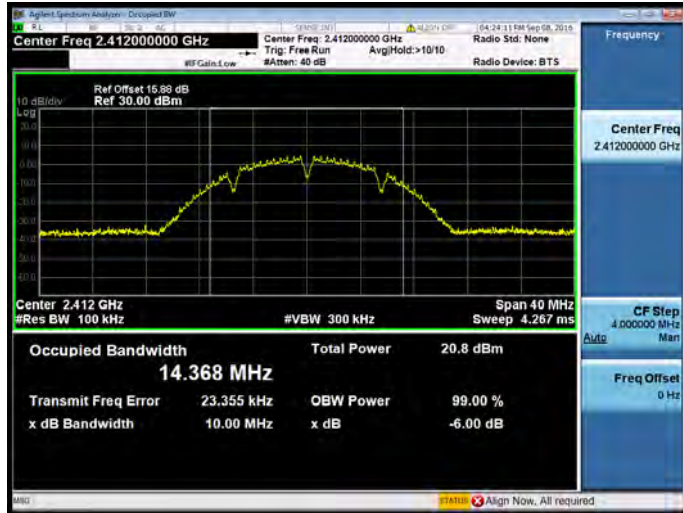

2437 MHz

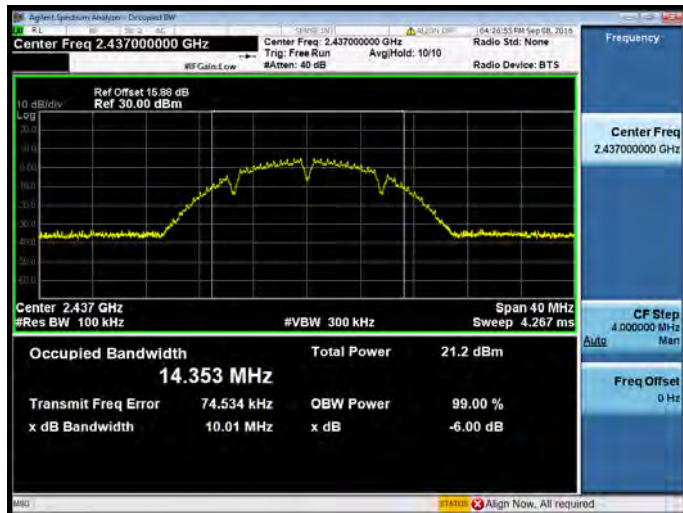

2462 MHz

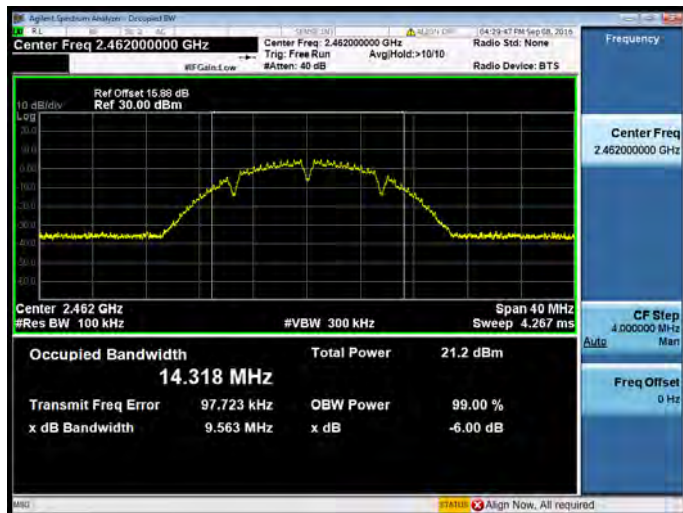



Mode 3: IEEE 802.11g link mode \_ANT-1

2412 MHz

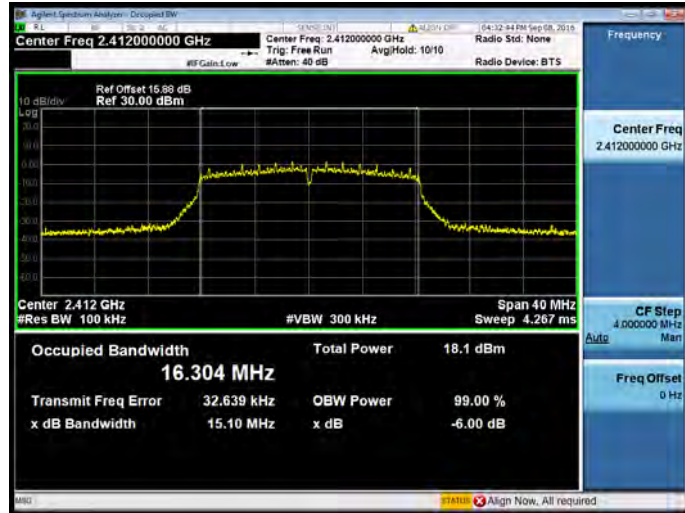

2437 MHz

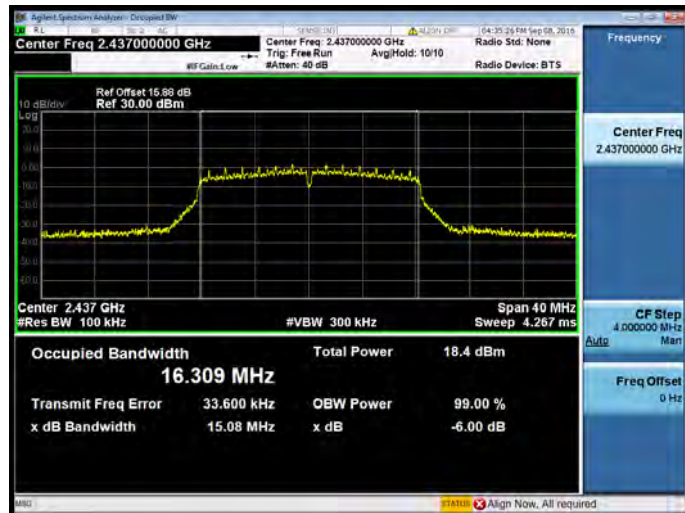

2462 MHz

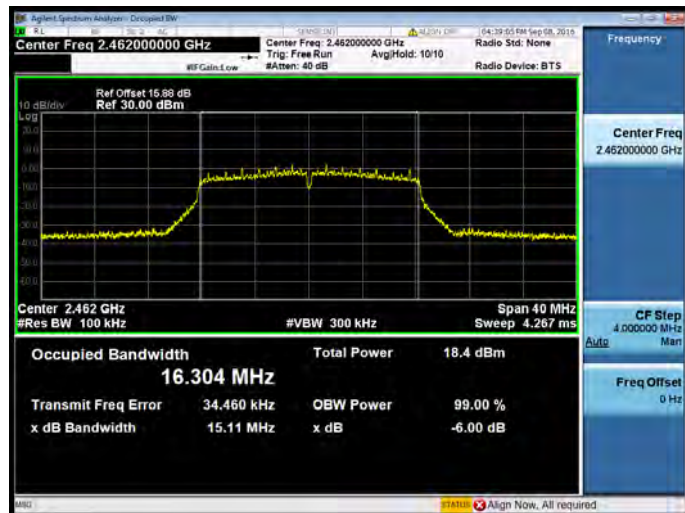





Mode 4: IEEE 802.11n 2.4GHz 20MHz link mode\_ANT-1

2412 MHz

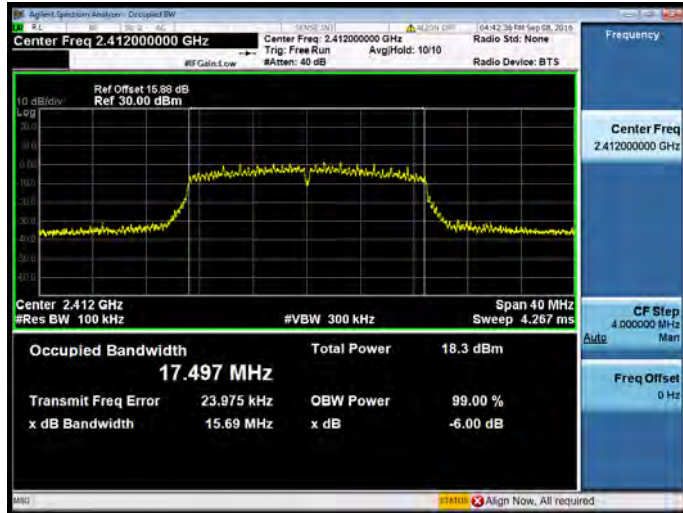

2437 MHz

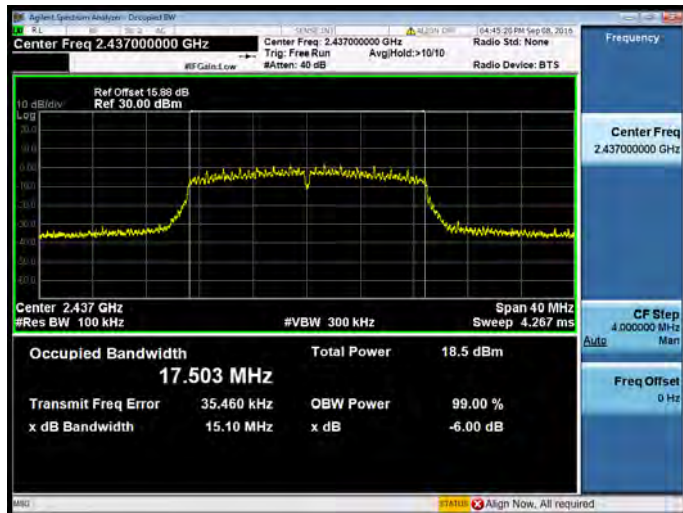

2462 MHz

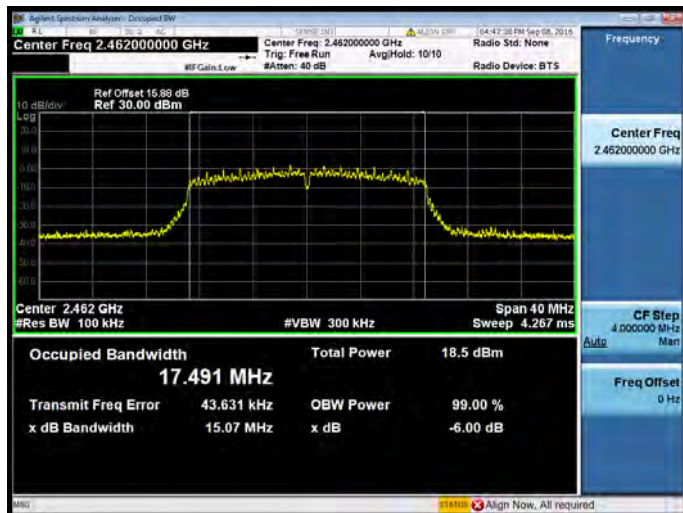



Mode 5: IEEE 802.11n 2.4GHz 40MHz link mode\_ANT-1

2422 MHz

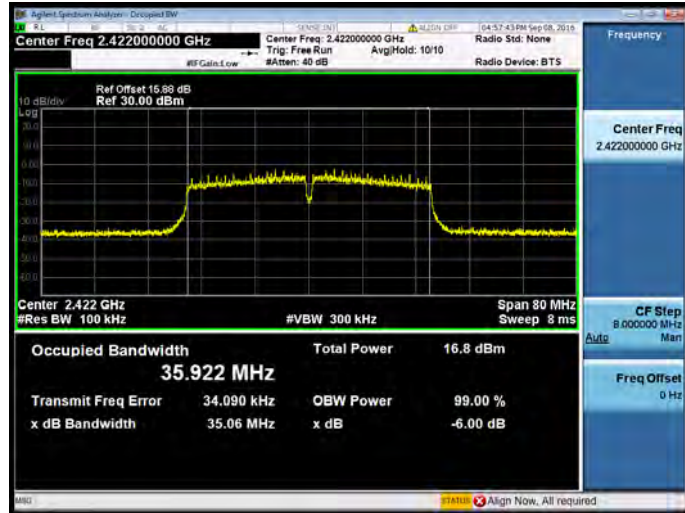

2437 MHz

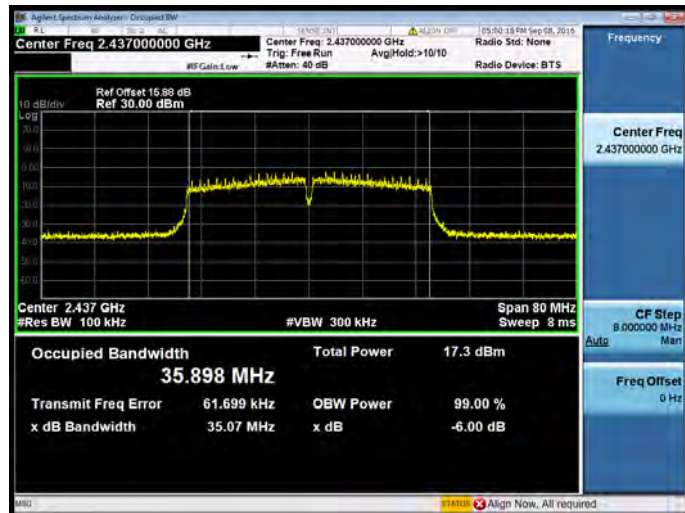

2452 MHz

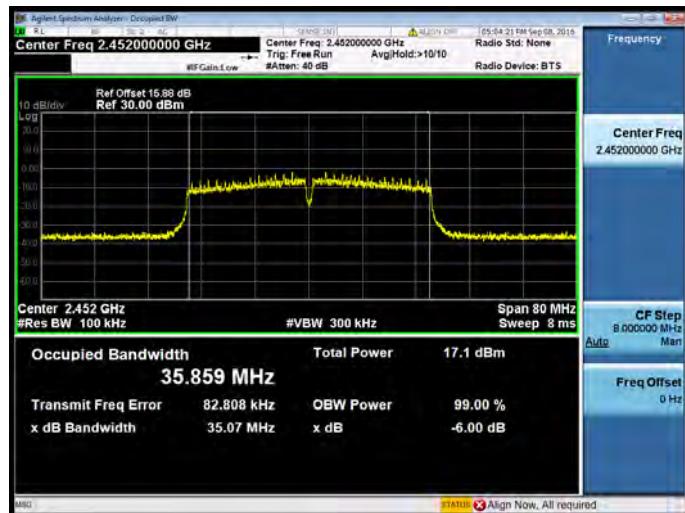

## 8 Maximum Power Density Measurement

### 8.1. Limit

For digitally modulated systems, the power spectral density conducted from the intentional radiator to the antenna shall not be greater than 8 dBm in any 3 kHz band during any time interval of continuous transmission.

\* MIMO mode : Directional Gain =  $GANT + 10 \cdot \log(NANT/NSS)$

### 8.2. Test Setup

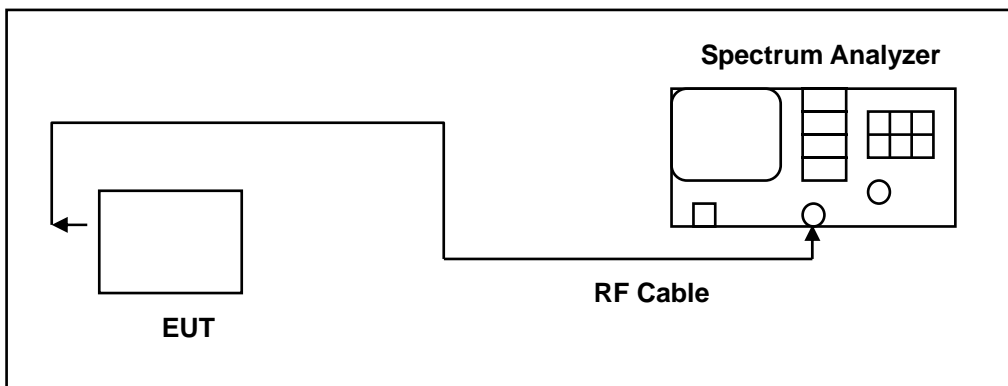

### 8.3. Test Instruments

Equipment	Manufacturer	Model Number	Serial Number	Cal. Date	Cal. Period
Spectrum Analyzer	Agilent	E4445A	MY45300744	12/15/2015	1 year
Microwave Cable	EMCI	EMC104-SM-SM-1500	140303	02/23/2016	1 year
Test Site	ATL	TE05	TE05	N.C.R.	-----

Note: N.C.R. = No Calibration Request.

### 8.4. Test Procedure

The EUT tested to DTS test procedure of KDB558074D01 for compliance to FCC 47CFR 15.247 requirements.

1. Set analyzer center frequency to DTS channel center frequency.
2. Set the span to 1.5 times the DTS bandwidth.
3. Set the RBW to:  $3 \text{ kHz} \leq \text{RBW} \leq 100 \text{ kHz}$ .
4. Set the VBW  $\geq 3 \times \text{RBW}$ .
5. Detector = peak.
6. Sweep time = auto couple.
7. Trace mode = max hold.
8. Allow trace to fully stabilize.
9. Use the peak marker function to determine the maximum amplitude level within the RBW.
10. If measured value exceeds limit, reduce RBW (no less than 3 kHz) and repeat.



### 8.5. Test Result



Model Number	OP1200							
Test Item	Maximum Power Density							
Date of Test	09/08/2016							
Test Mode	Frequency (MHz)	Measurement (dBm/30KHz)		Duty Factor	Max. Power Density (dBm/30KHz)			Limit (dBm/3KHz)
		ANT-0	ANT-1		ANT-0	ANT-1	ANT-0+	
Mode 2	2412	0.449	3.877	0.111	0.560	3.988	5.614	< 8
	2437	4.156	4.118	0.111	4.267	4.229	7.258	< 8
	2462	4.201	4.145	0.111	4.312	4.256	7.294	< 8
Mode 3	2412	-4.682	-3.521	0.496	-4.186	-3.025	-0.557	< 8
	2437	-4.817	-2.194	0.496	-4.321	-1.698	0.196	< 8
	2462	-5.057	-1.740	0.496	-4.561	-1.244	0.417	< 8
Mode 4	2412	-2.715	-2.515	0.598	-2.117	-1.917	0.994	< 8
	2437	-2.138	-2.478	0.598	-1.540	-1.880	1.304	< 8
	2462	-2.019	-2.741	0.598	-1.421	-2.143	1.243	< 8
Mode 5	2422	-7.459	-8.492	1.513	-5.946	-6.979	-3.422	< 8
	2437	-7.681	-8.060	1.513	-6.168	-6.547	-3.343	< 8
	2452	-7.624	-7.535	1.513	-6.111	-6.022	-3.056	< 8

Note: The Max. Power Density = measurement + duty factor.



### 8.6. Test Graphs

Mode 2: IEEE 802.11b link mode\_ANT-0

2412 MHz	
2437 MHz	
2462 MHz	



Mode 3: IEEE 802.11g link mode \_ANT-0

2412 MHz

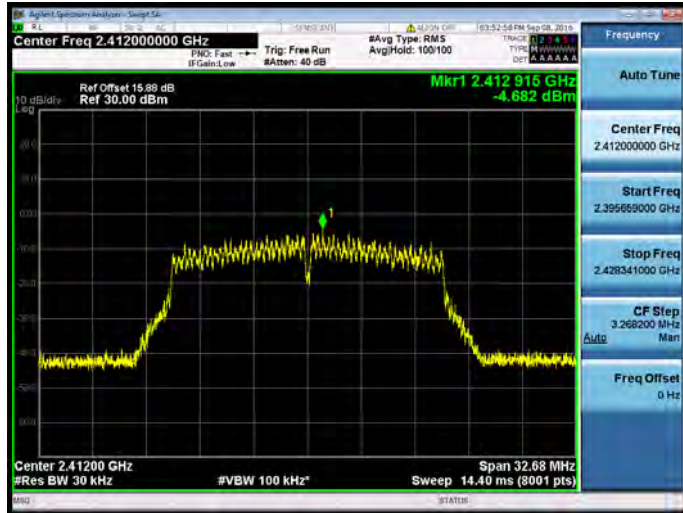

2437 MHz

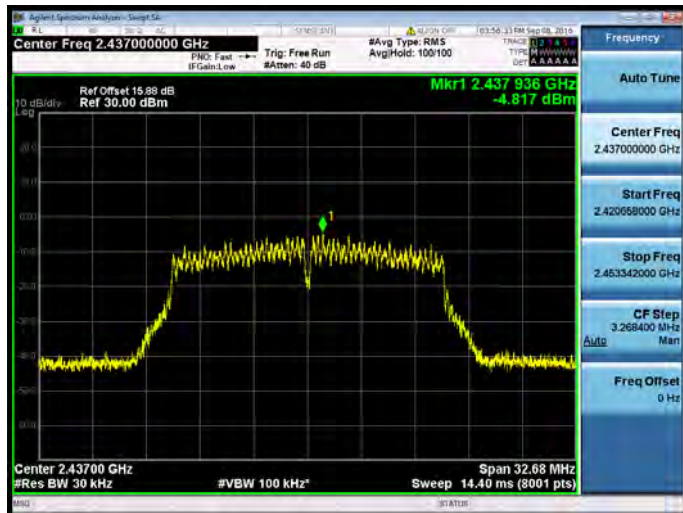

2462 MHz

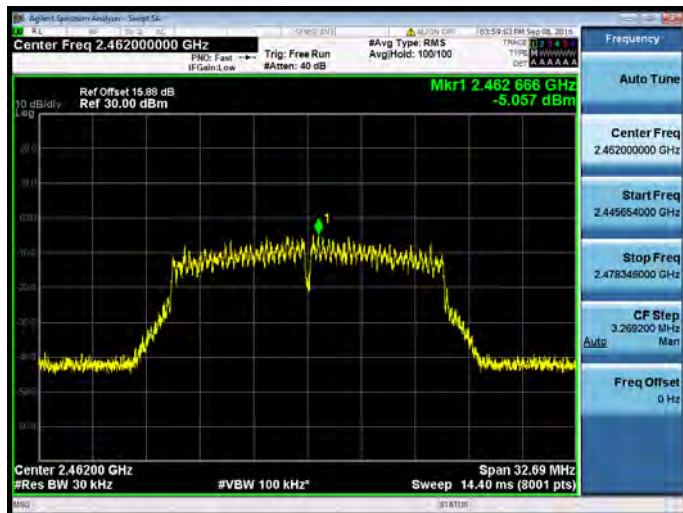



Mode 4: IEEE 802.11n 2.4GHz 20MHz link mode\_ANT-0

2412 MHz



2437 MHz

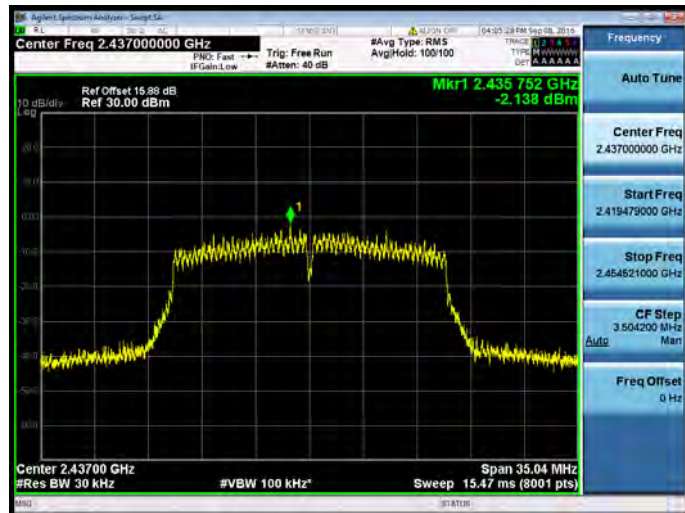

2462 MHz





Mode 5: IEEE 802.11n 2.4GHz 40MHz link mode\_ANT-0

2422 MHz



2437 MHz

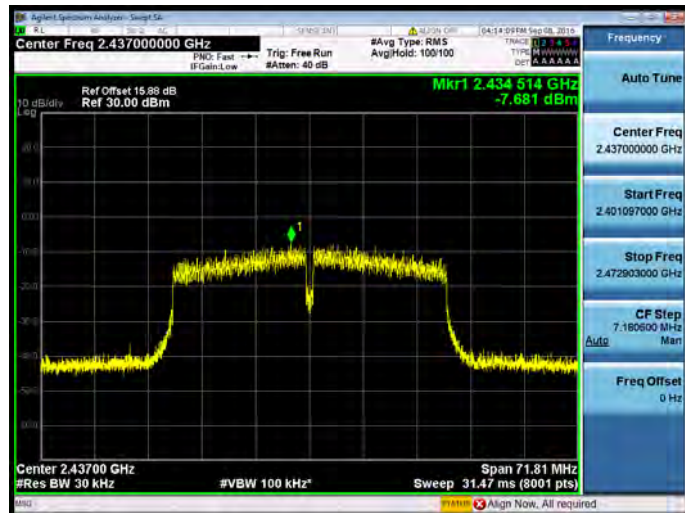

2452 MHz

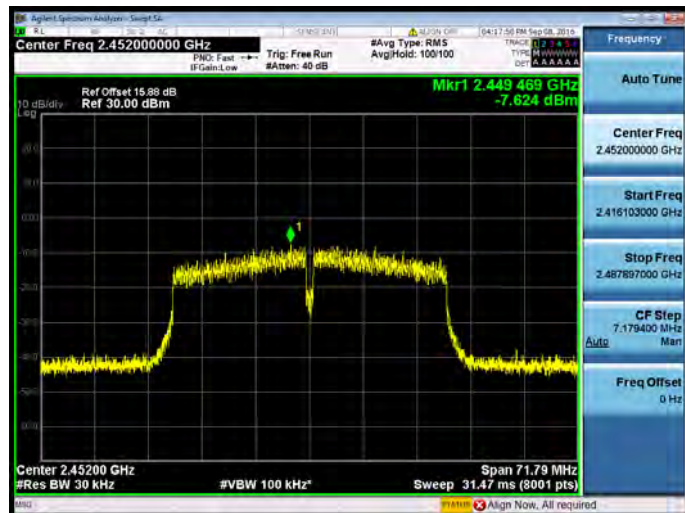





Mode 2: IEEE 802.11b link mode\_ANT-1

2412 MHz



2437 MHz



2462 MHz





Mode 3: IEEE 802.11g link mode \_ANT-1

2412 MHz

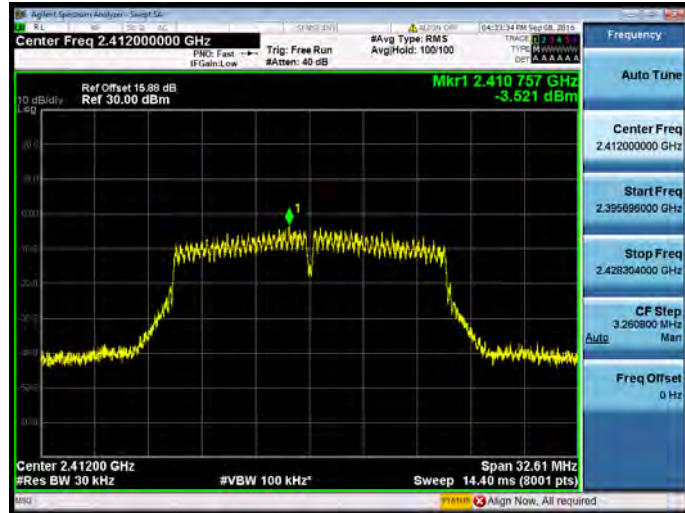

2437 MHz

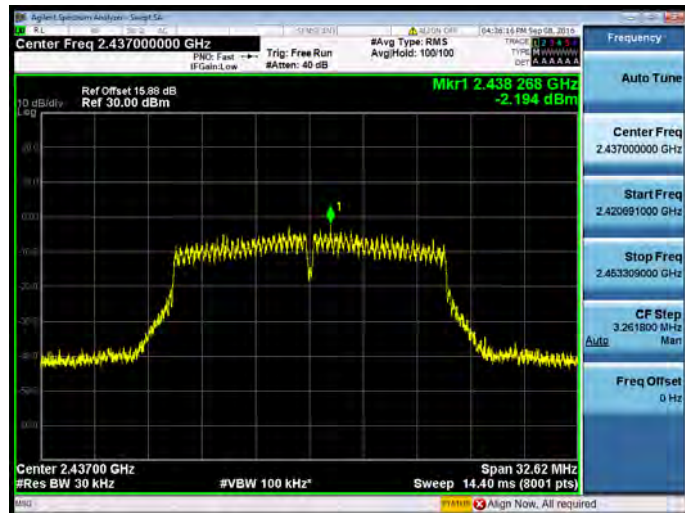

2462 MHz

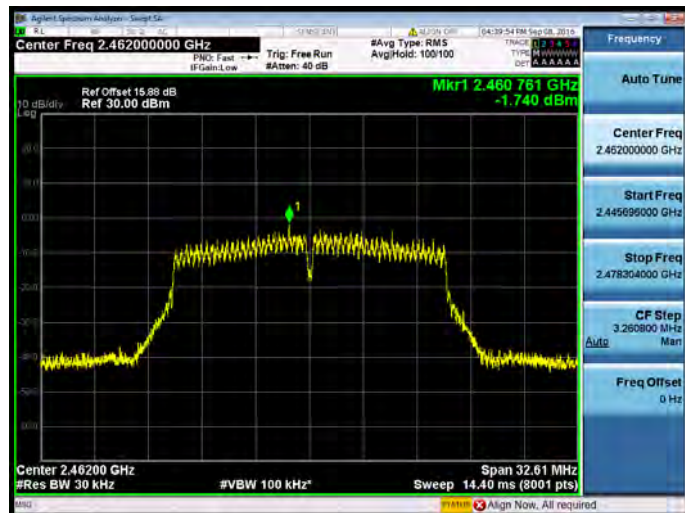



Mode 4: IEEE 802.11n 2.4GHz 20MHz link mode\_ANT-1

2412 MHz

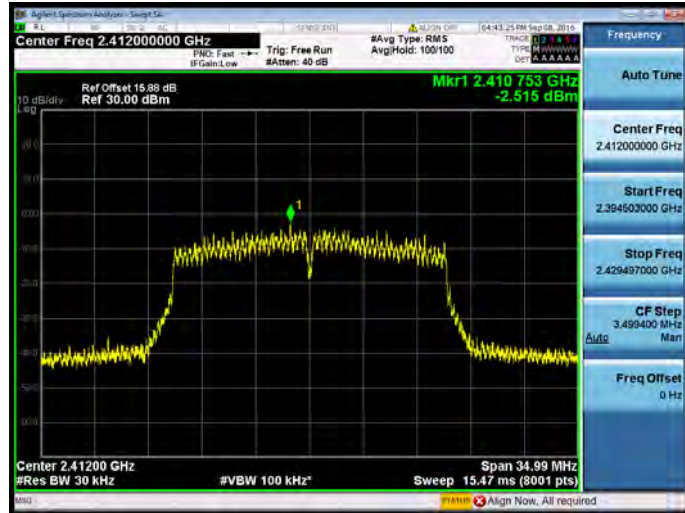

2437 MHz

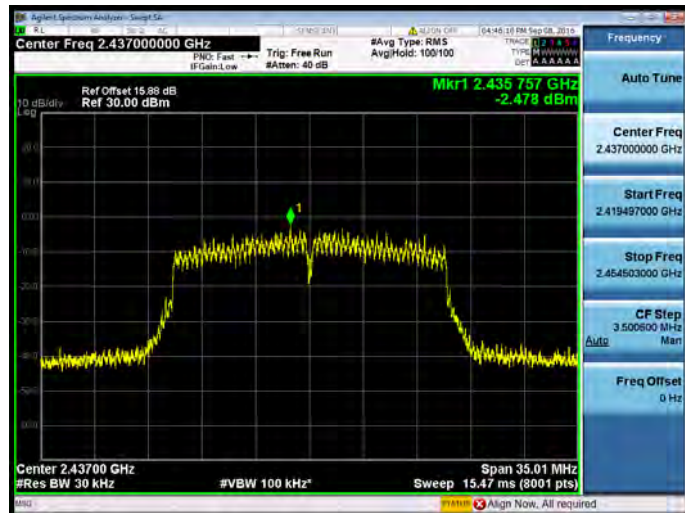

2462 MHz

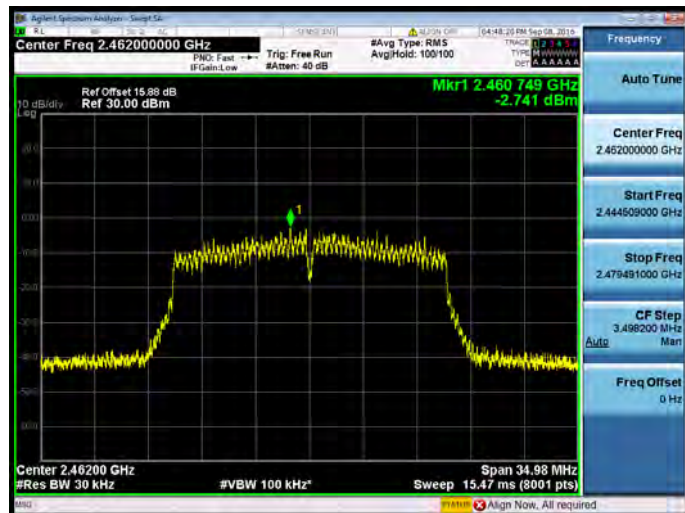



Mode 5: IEEE 802.11n 2.4GHz 40MHz link mode\_ANT-1

2422 MHz

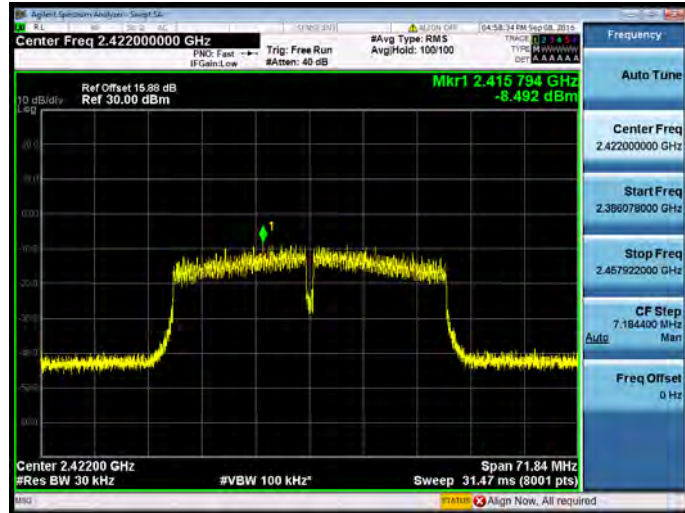

2437 MHz

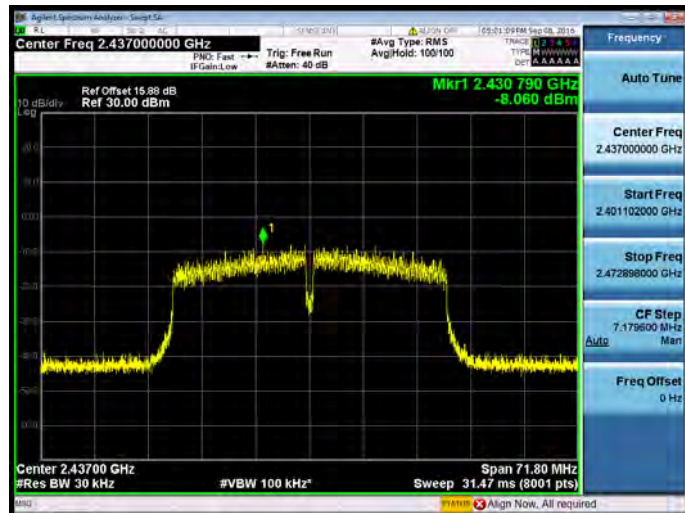

2452 MHz

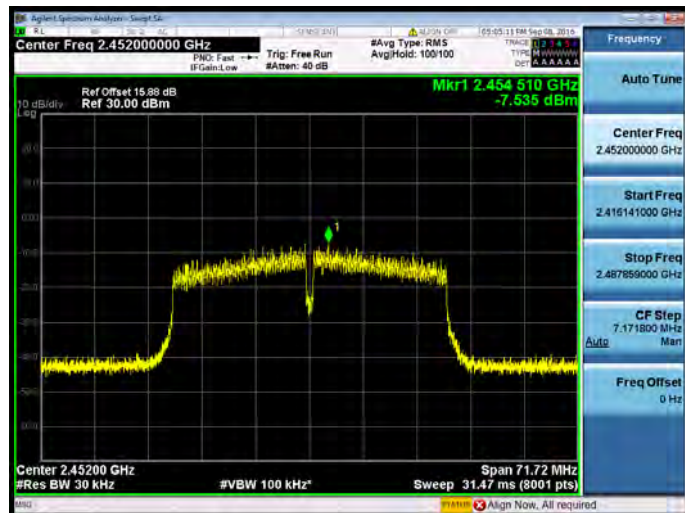

## 9 Out of Band Conducted Emissions Measurement

### 9.1. Limit

In any 100 kHz bandwidth outside the frequency band in which the spread spectrum or digitally modulated intentional radiator is operating, the radio frequency power that is produced by the intentional radiator shall be at least 20 dB below that in the 100 kHz bandwidth within the band that contains the highest level of the desired power

### 9.2. Test Setup

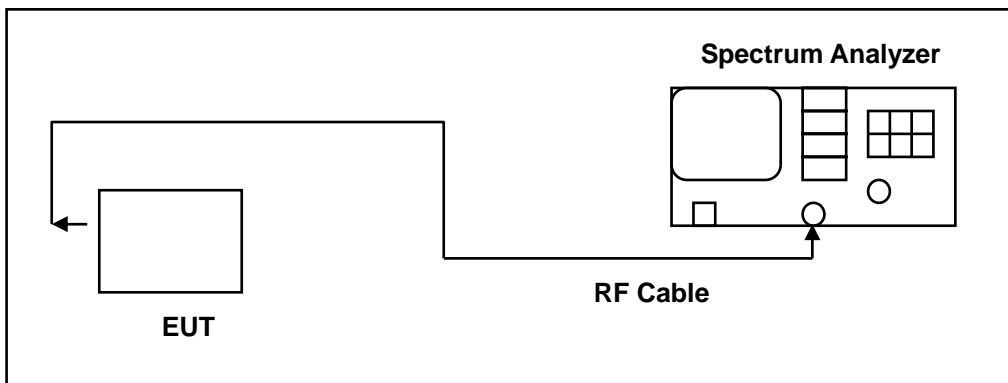

### 9.3. Test Instruments

Equipment	Manufacturer	Model Number	Serial Number	Cal. Date	Cal. Period
Spectrum Analyzer	Agilent	E4445A	MY45300744	12/15/2015	1 year
Spectrum Analyzer	Agilent	E4408B	MY45107753	08/08/2016	1 year
Microwave Cable	EMCI	EMC104-SM-SM-1500	140303	02/23/2016	1 year
Test Site	ATL	TE05	TE05	N.C.R.	-----

Note: N.C.R. = No Calibration Request.

### 9.4. Test Procedure

In any 100 kHz bandwidth outside the EUT pass band, the RF power produced by the modulation products of the spreading sequence, the information sequence, and the carrier frequency shall be at least 20 dB below that of the maximum in-band 100 kHz emission, antenna output of the EUT was coupled directly to spectrum analyzer; if an external attenuator and/or cable was used, these losses are compensated for with the analyzer OFFSET function.

All other types of emissions from the EUT shall meet the general limits for radiated frequencies outside the pass band.



The test was performed at 3 channels.



### 9.5. Test Graphs

#### Reference level

Mode 2: IEEE 802.11b link mode\_ANT-0

2412 MHz	
2437 MHz	
2462 MHz	



Mode 3: IEEE 802.11g link mode \_ANT-0

2412 MHz

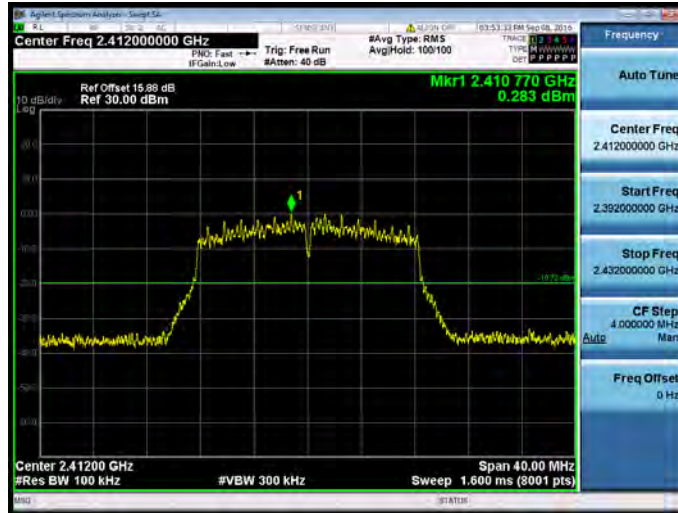

2437 MHz

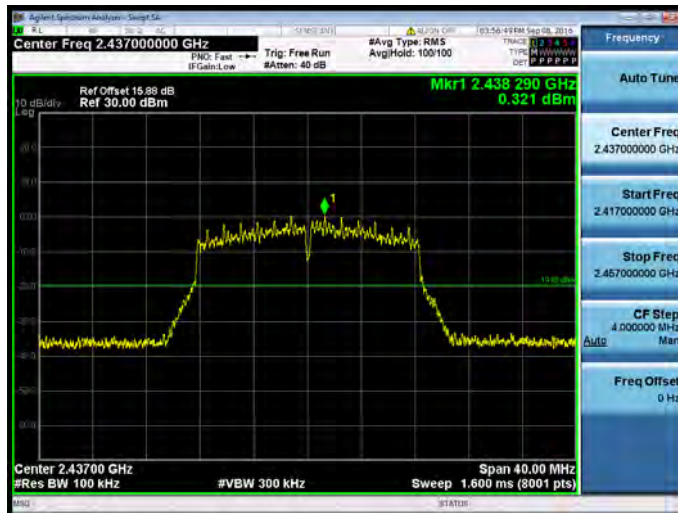

2462 MHz

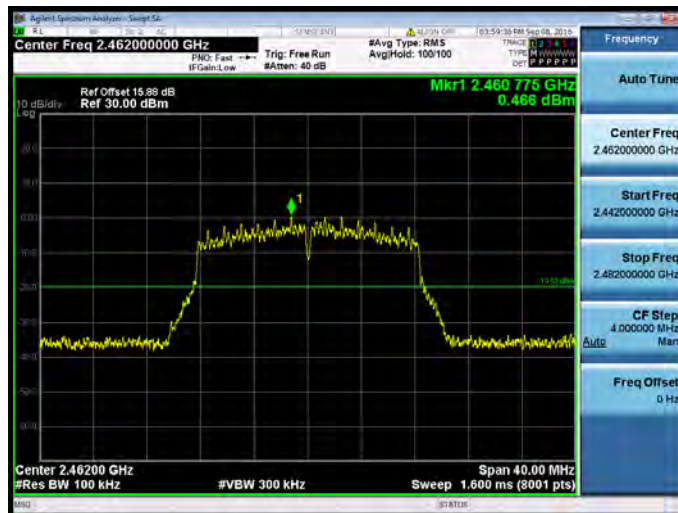



Mode 4: IEEE 802.11n 2.4GHz 20MHz link mode\_ANT-0

2412 MHz



2437 MHz

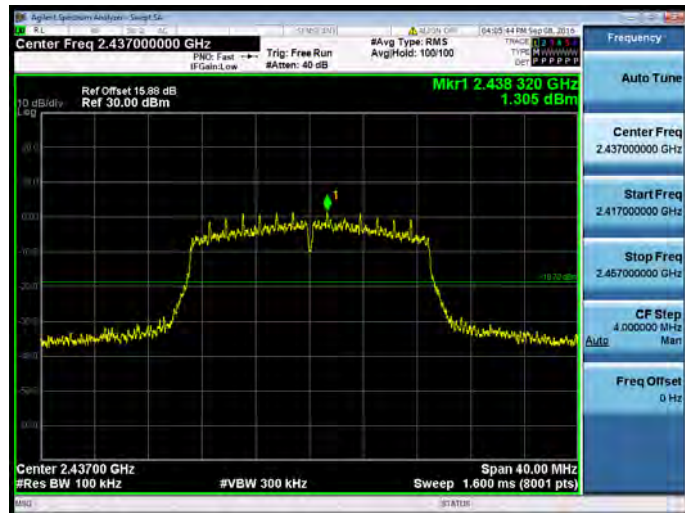

2462 MHz

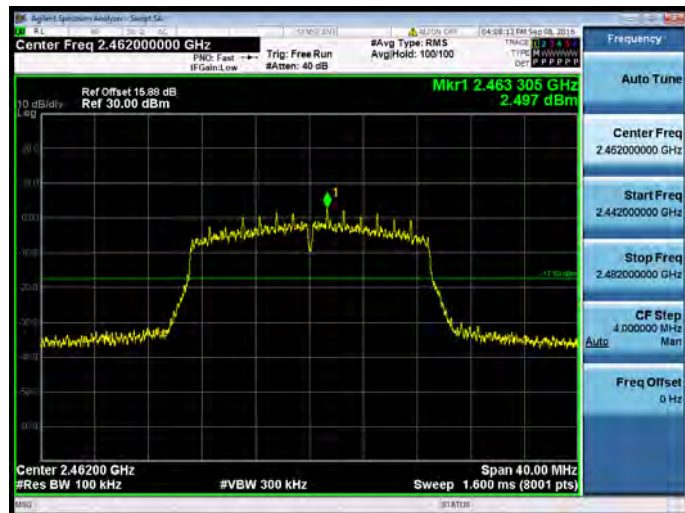





Mode 5: IEEE 802.11n 2.4GHz 40MHz link mode\_ANT-0

2422 MHz



2437 MHz

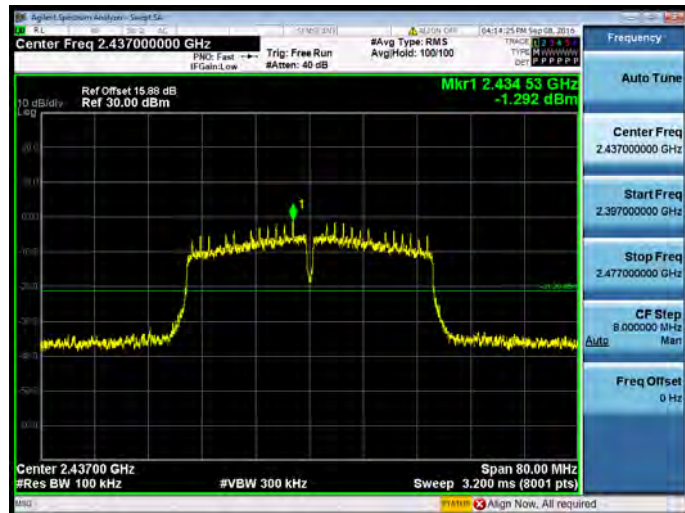

2452 MHz





Mode 2: IEEE 802.11b link mode\_ANT-1

2412 MHz



2437 MHz

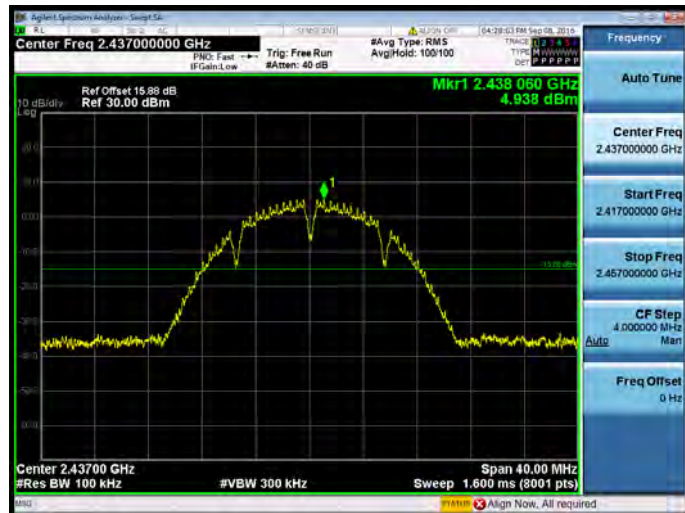

2462 MHz



Mode 3: IEEE 802.11g link mode \_ANT-1

2412 MHz



2437 MHz

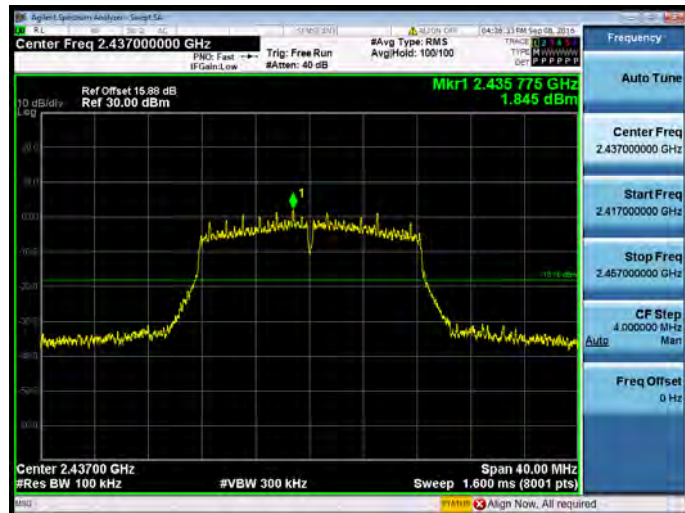

2462 MHz

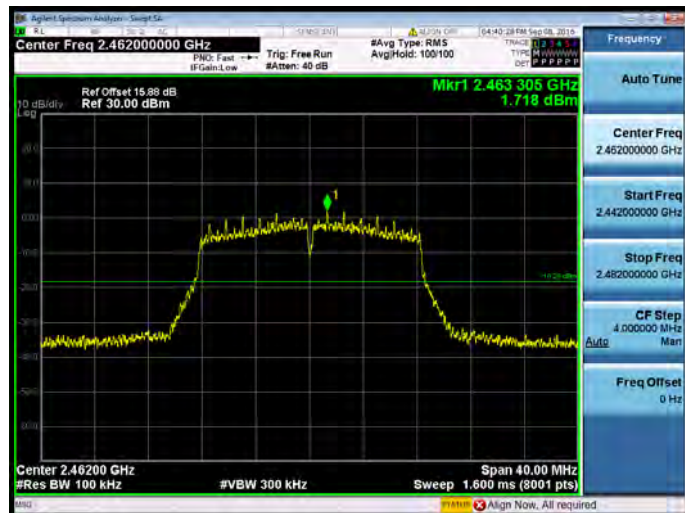



Mode 4: IEEE 802.11n 2.4GHz 20MHz link mode\_ANT-1

2412 MHz



2437 MHz

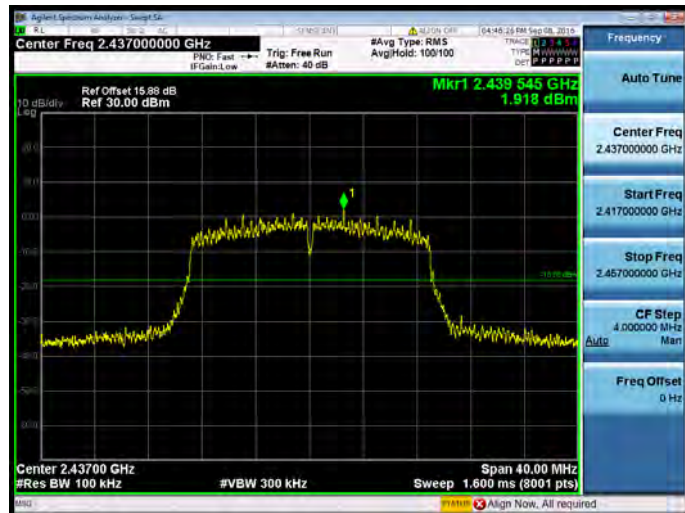

2462 MHz

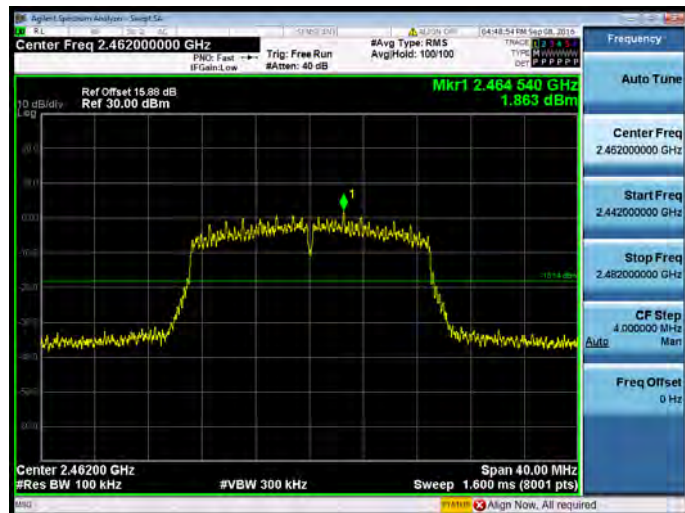



Mode 5: IEEE 802.11n 2.4GHz 40MHz link mode\_ANT-1

2422 MHz

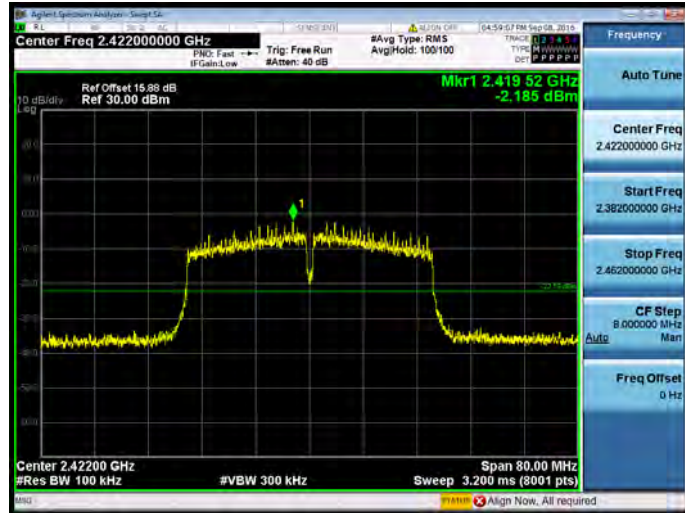

2437 MHz

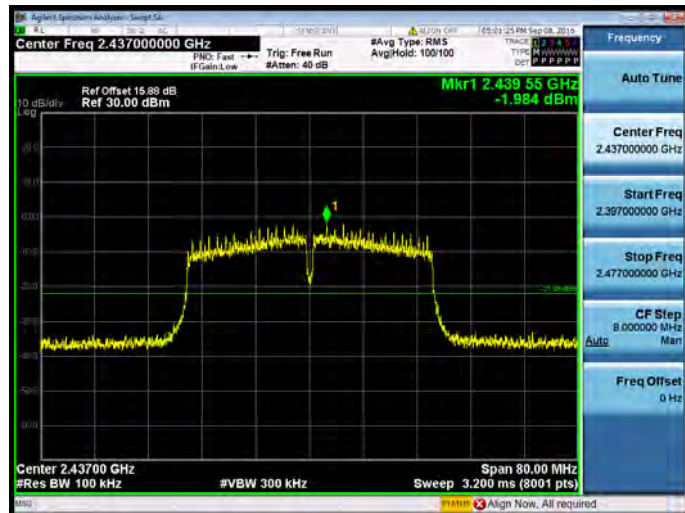

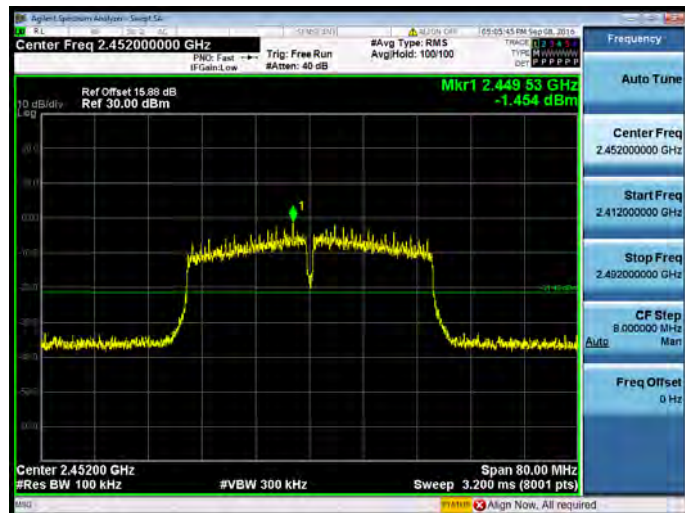

2452 MHz



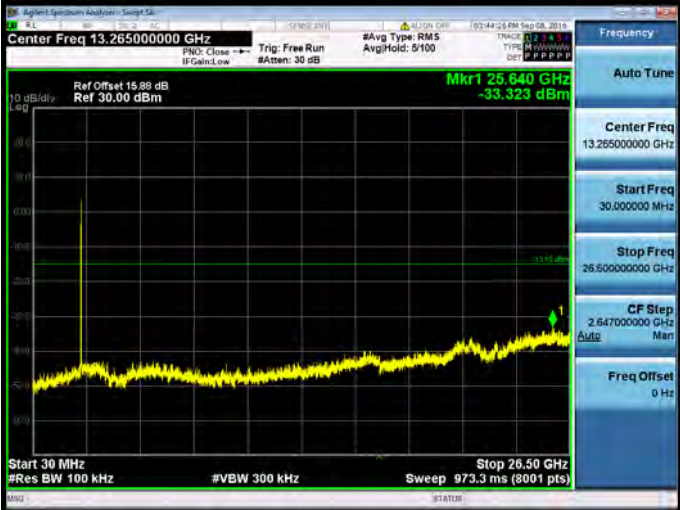

### Out of Band Conducted Emissions

Mode 2: IEEE 802.11b link mode\_ANT-0

2412 MHz	
2437 MHz	
2462 MHz	



Mode 3: IEEE 802.11g link mode \_ANT-0

2412 MHz



2437 MHz



2462 MHz





Mode 4: IEEE 802.11n 2.4GHz 20MHz link mode\_ANT-0

2412 MHz



2437 MHz



2462 MHz







Mode 5: IEEE 802.11n 2.4GHz 40MHz link mode\_ANT-0

2422 MHz



2437 MHz

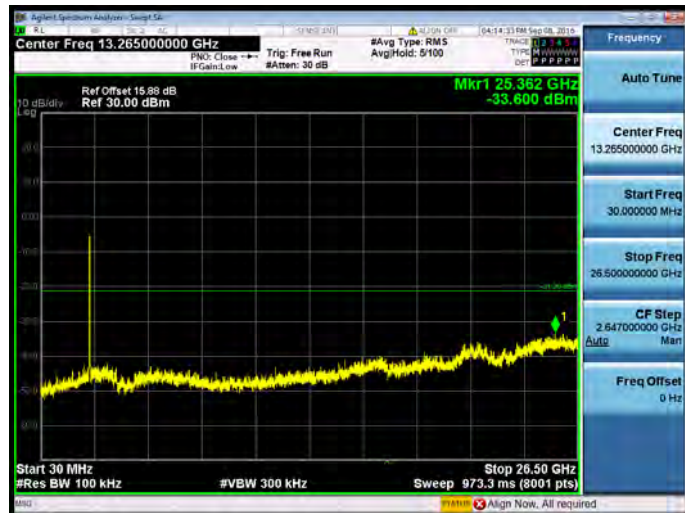

2452 MHz

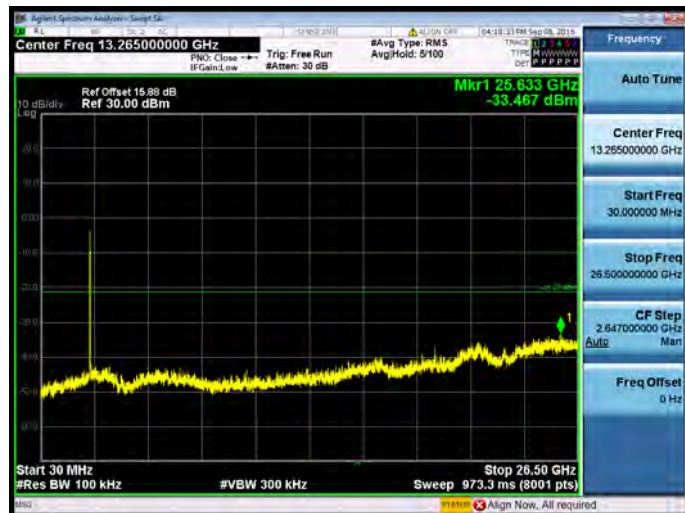



Mode 2: IEEE 802.11b link mode\_ANT-1

2412 MHz



2437 MHz



2462 MHz





Mode 3: IEEE 802.11g link mode \_ANT-1

2412 MHz



2437 MHz



2462 MHz





Mode 4: IEEE 802.11n 2.4GHz 20MHz link mode\_ANT-1

2412 MHz



2437 MHz

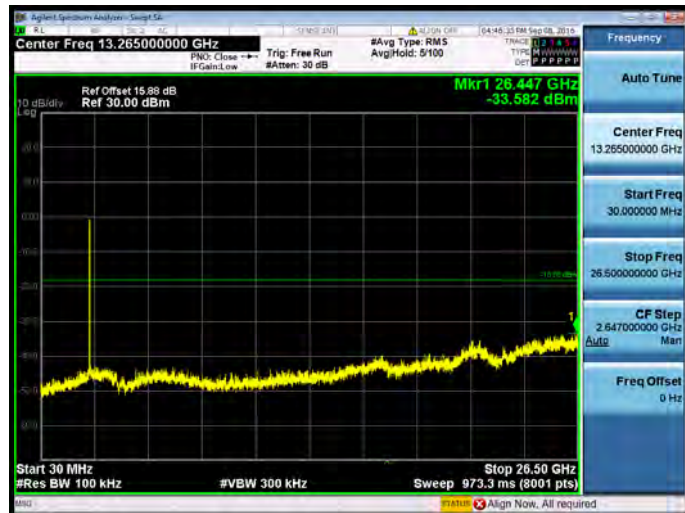

2462 MHz





Mode 5: IEEE 802.11n 2.4GHz 40MHz link mode\_ANT-1

2422 MHz



2437 MHz



2452 MHz

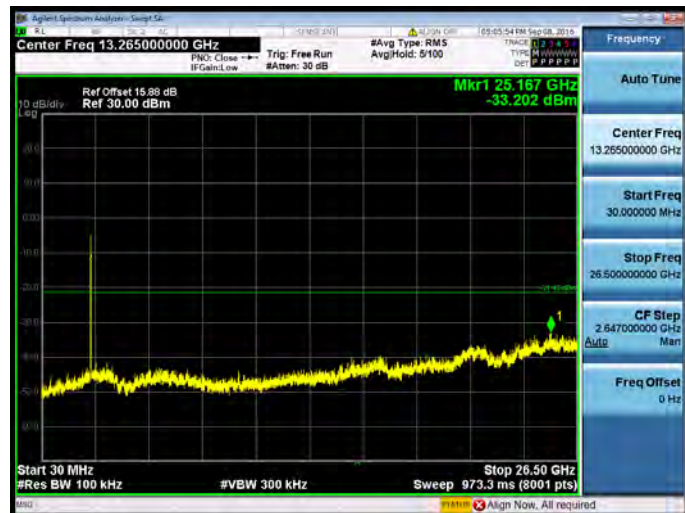

**Conducted Band Edge**

Mode 2: IEEE 802.11b link mode\_ANT-0

2412 MHz

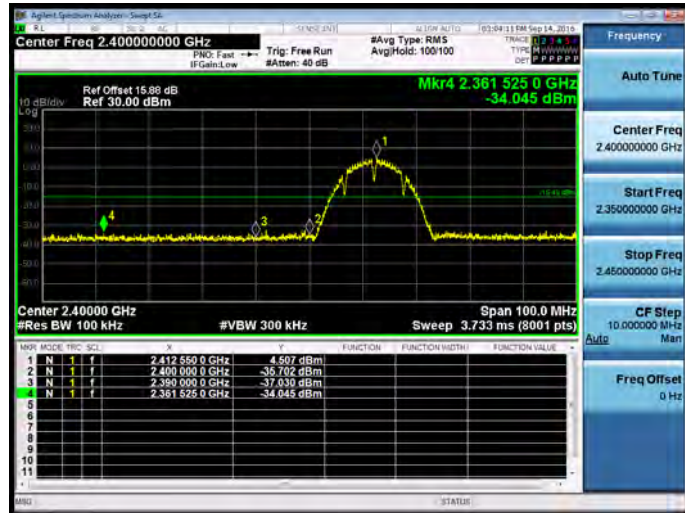

2462 MHz

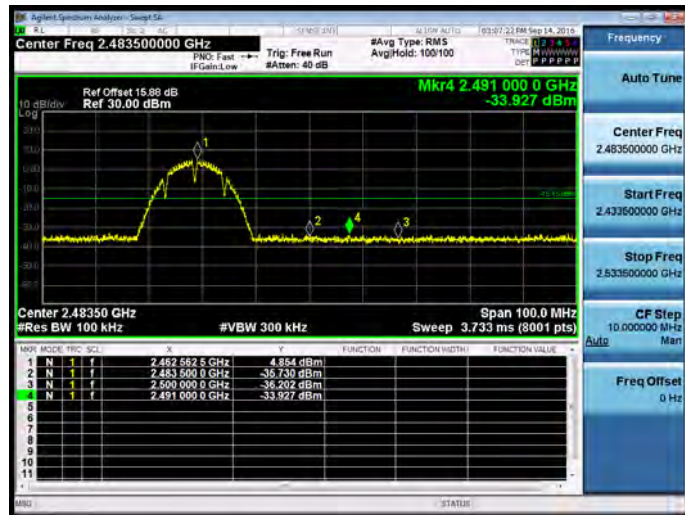



Mode 3: IEEE 802.11g link mode \_ANT-0

2412 MHz

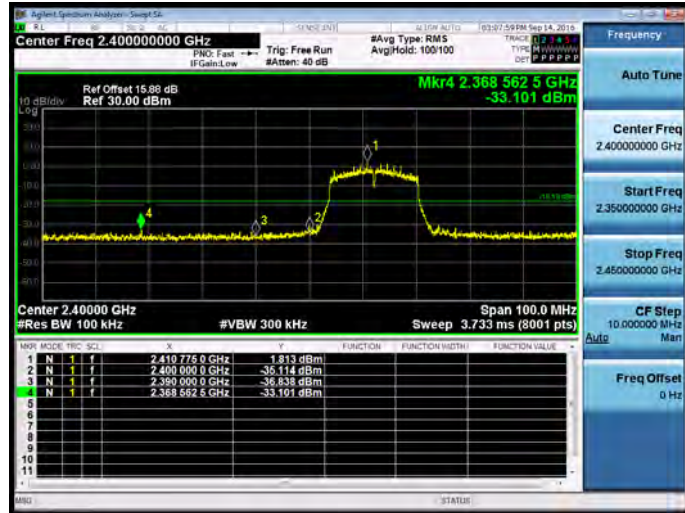

2462 MHz

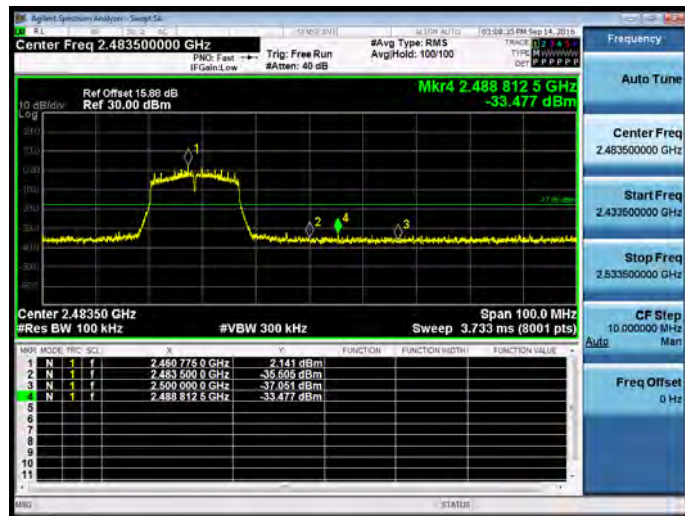

Mode 4: IEEE 802.11n 2.4GHz 20MHz link mode\_ANT-0

2412 MHz

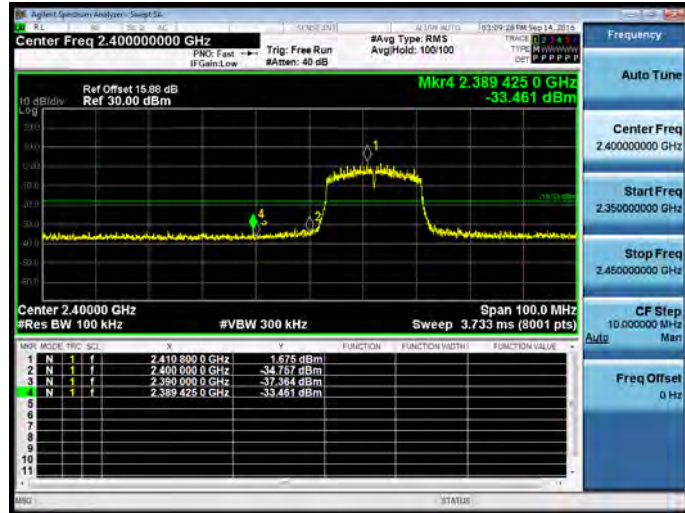

2462 MHz

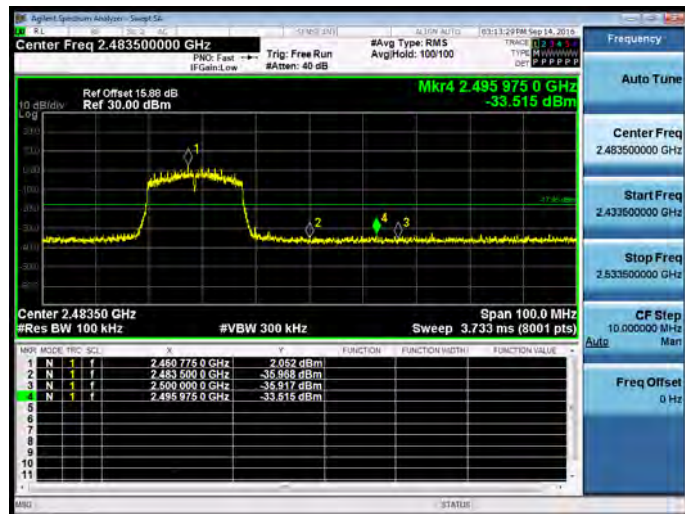





Mode 5: IEEE 802.11n 2.4GHz 40MHz link mode\_ANT-0

2422 MHz

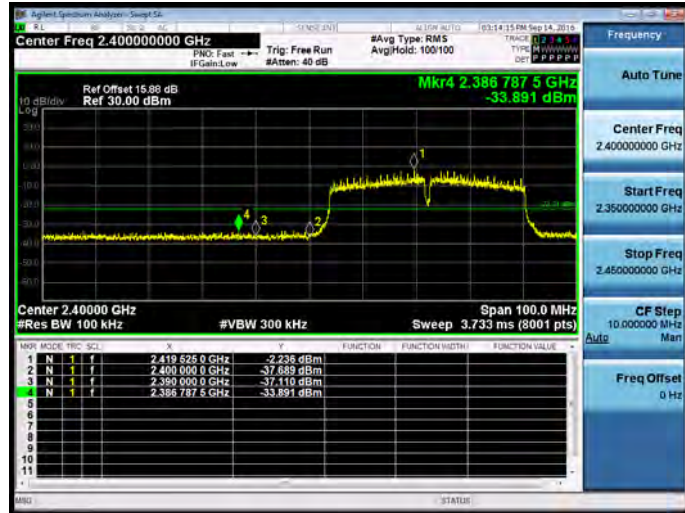

2452 MHz

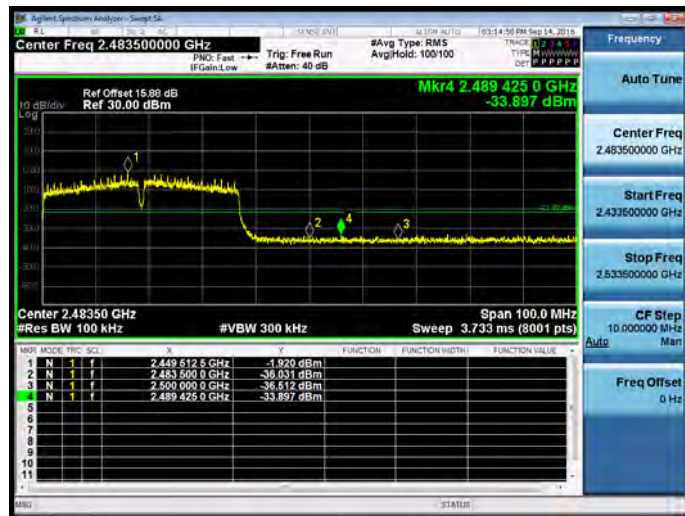

Mode 2: IEEE 802.11b link mode\_ANT-1

2412 MHz

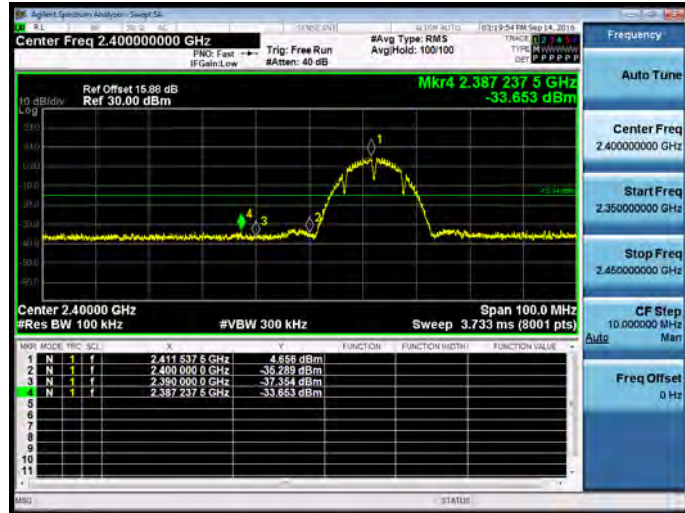

2462 MHz

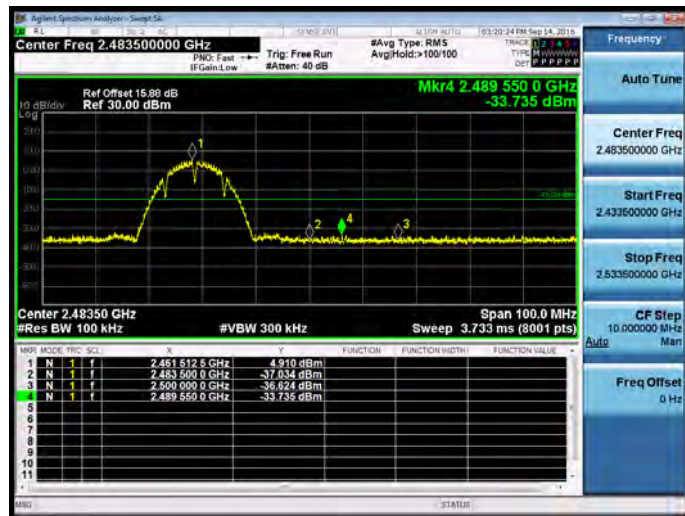



Mode 3: IEEE 802.11g link mode \_ANT-1

2412 MHz

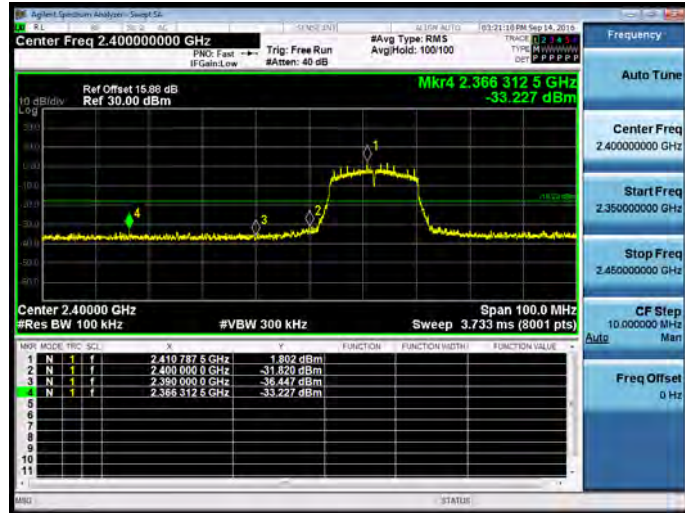

2462 MHz

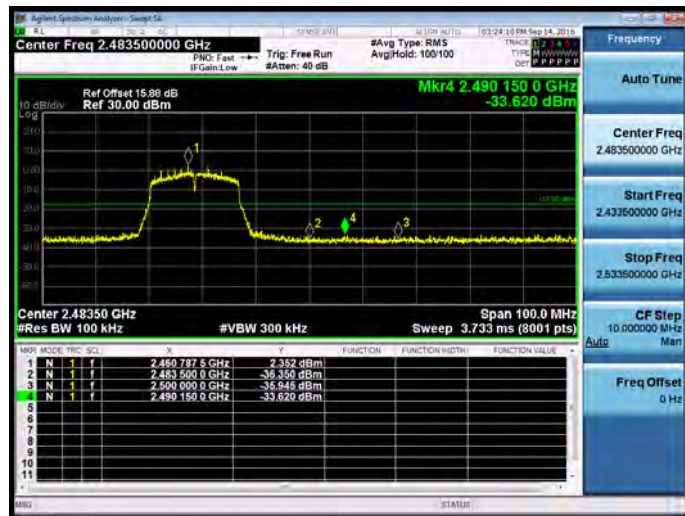



Mode 4: IEEE 802.11n 2.4GHz 20MHz link mode\_ANT-1

2412 MHz

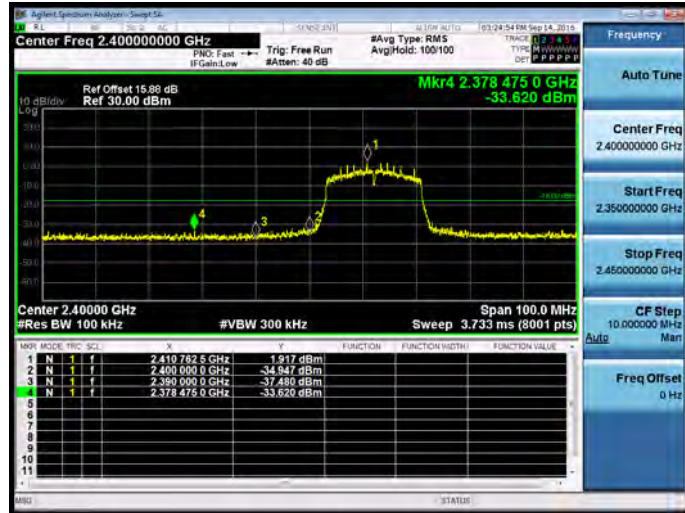

2462 MHz

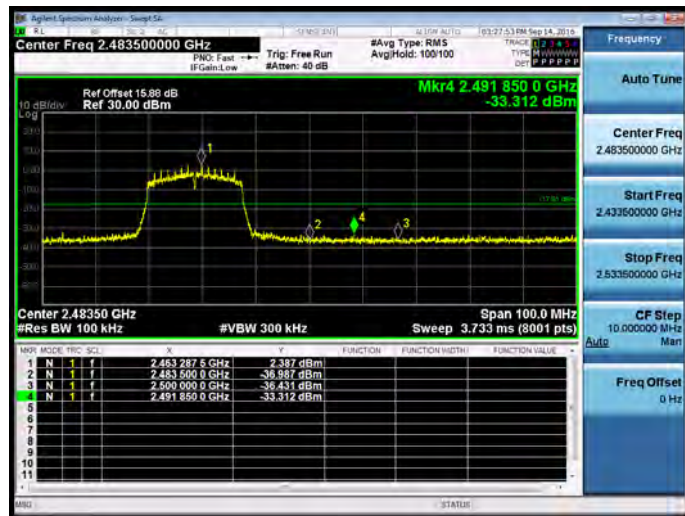



Mode 5: IEEE 802.11n 2.4GHz 40MHz link mode\_ANT-1

2422 MHz

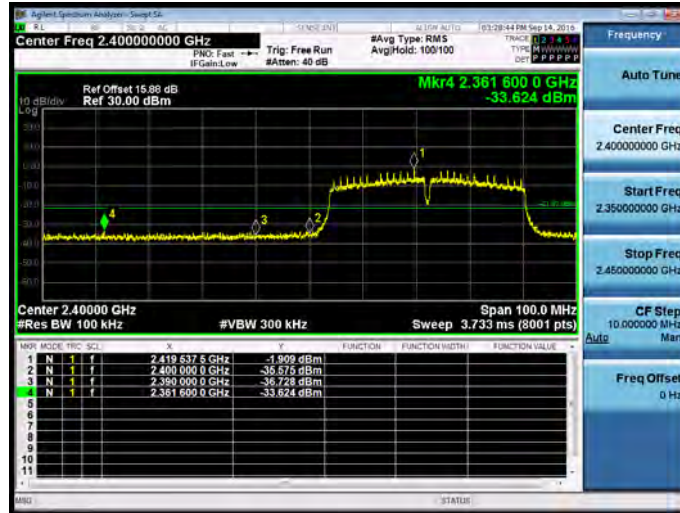

2452 MHz

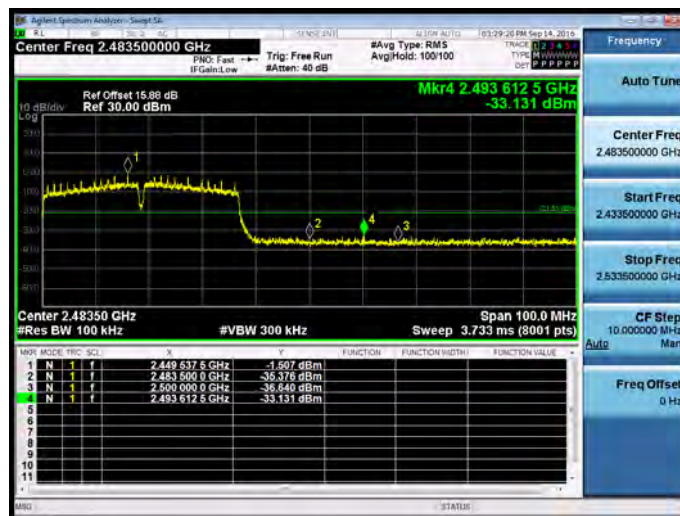



## 10 Antenna Measurement

### 10.1.Limit

For intentional device, according to 15.203, an intentional radiator shall be designed to ensure that no antenna other than that furnished by the responsible party shall be used with the device.

And According to 15.247 (b), if transmitting antennas of directional gain greater than 6 dBi are used, the power shall be reduced by the amount in dB that the directional gain of the antenna exceeds 6dBi.

### 10.2.Antenna Description

See section 2 – antenna information.

### 10.3.Directiona Gain Calculated

Directional Gain =  $GANT + 10 \cdot \log(NANT/NSS)$

Operate Freq. Band	Directional Gain (dBi)
IEEE 802.11b	5.01
IEEE 802.11g link mode	5.01
IEEE 802.11n 2.4GHz 20MHz	5.01
IEEE 802.11n 2.4GHz 40MHz	5.01