



# FCC TEST REPORT

Page 1 of 16

**LAB LOCATION:**  
**DATE IN:**

**DONG GUAN, CHINA**  
**May. 15, 2016**

**REPORT NUMBER:**  
**DATE OUT:**

**65316-050008-2**  
**May. 30, 2016**

Product Description : GAMES HUB 360° STUNT CAR

Style No. : /

Model No. : /

P.O/Order No. : /

FCC ID : 2AIFF002

Applicant's name : RM International (USA) Inc.

Address : The Village At Beacon Centre, Suite 111, 8323 NW 12th Street, Miami, Florida, 33126, USA

Manufacturer : RM International (USA) Inc.

Address : The Village At Beacon Centre, Suite 111, 8323 NW 12th Street, Miami, Florida, 33126, USA

Laboratory Name : Modern Testing Services (Dongguan) Limited  
Address : No.76, Liang Ping Road, Xin Jiu Wei Village, Liaobu, Town Dongguan City, Guangdong Province, China  
Tel: (86)769-81120818  
Fax: (86)769-81120815

Report No. : 65316-050008-2



# FCC TEST REPORT

## TEST RESULT CERTIFICATION

**Applicant's name** ..... : RM International (USA) Inc.  
 Address ..... : The Village At Beacon Centre, Suite 111, 8323 NW 12th  
 Street, Miami, Florida, 33126, USA

**Manufacture's Name** ..... : RM International (USA) Inc.  
 Address ..... : The Village At Beacon Centre, Suite 111, 8323 NW 12th  
 Street, Miami, Florida, 33126, USA

### Product description

Trade Mark: /  
 Product name..... : GAMES HUB 360° STUNT CAR  
 Style No. .... : /

**Standards** ..... : FCC Rules and Regulations Part 15 Subpart C Section 15.235  
 ANSI C63.10: 2013

This publication may be reproduced in whole or in part for non-commercial purposes as long as the Modern Testing Services (Dongguan) Limited is acknowledged as copyright owner and source of the material. Modern Testing Services (Dongguan) Limited takes no responsibility for and will not assume liability for damages resulting from the reader's interpretation of the reproduced material due to its placement and context.

**Date of Test** ..... :  
 Date (s) of performance of tests ..... : **May. 15, 2016 ~ May. 30, 2016**  
 Date of Issue..... : **May. 30, 2016**  
 Test Result..... : **Pass**

Prepared by:

  
 \_\_\_\_\_  
 JANG Ping, Loken  
 Project Engineer

Reviewed by:

  
 \_\_\_\_\_  
 WANG Yang, Oscar  
 Project Supervisor

Approved by:

  
 \_\_\_\_\_  
 CHEN Chu Peng, Ken  
 EMC Manager

Table of Contents	Page
1 . TEST SUMMARY	4
2 . GENERAL INFORMATION	5
2.1 General Description of EUT	5
2.2 Operation of EUT during testing	6
2.3 Description of Test Setup	6
2.4 Measurement Instruments List	7
3 . CONDUCTED EMISSION TEST	9
3.1 Block Diagram of Test Setup	9
3.2 Conducted Power Line Emission Limit	9
3.3 Test Procedure	9
3.4 Test Result	9
4 . RADIATED EMISSION TEST	10
4.1 Block Diagram of Test Setup	10
4.2 Limits	11
4.3 Test Procedure	11
4.4 Test Result	11
6. OCCUPIED BANDWIDTH MEASUREMENT	13
6.1 Block Diagram of Test Setup	13
6.2 Test Procedure	13
6.3 Test Result	13
7. ANTENNA REQUIREMENT	15
8. PHOTOGRAPH OF TEST	16

## 1. TEST SUMMARY

### 1.1 Description of Test

Description of Test	Result
CONDUCTED EMISSIONS TEST	Compliant
RADIATED EMISSION TEST	Compliant
OCCUPIED BANDWIDTH MEASUREMENT	Compliant
ANTENNA REQUIREMENT	Compliant

### 1.2 Test Location

Test Firm : Dongguan Dongdian Testing Service Co., Ltd  
Address : No.17 Zongbu road 2, Songshan Lake Sci&Tech, DongGuan  
City, Guangdong province,523808 China  
FCC Registration Number: 270092

### 1.3 Measurement Uncertainty

#### Measurement Uncertainty

Conducted Emission Expanded Uncertainty = 2.23dB, k=2  
Radiated emission expanded uncertainty(9kHz-30MHz) = 3.08dB, k=2  
Radiated emission expanded uncertainty(30MHz-1000MHz) = 4.42dB, k=2  
Radiated emission expanded uncertainty(Above 1GHz) = 4.06dB, k=2

## 2. GENERAL INFORMATION

### 2.1 General Description of EUT

Equipment : GAMES HUB 360°STUNT CAR  
Style No. : /  
P.O/Order No. : /  
FCC ID : 22AIFF002  
Model Difference : /  
Modulation Type : ASK  
Antenna Type : Internal antenna  
Antenna Gain : 0 dBi  
Operation frequency : 49.86MHz  
Number of Channels : 1CH  
Data Rate : /  
Modulation Type : /  
Power Source : 2 x AAA (1.5V) batteries  
Power Rating : 3V DC  
Adapter Model : /



# FCC TEST REPORT

## 2.2 Operation of EUT during testing

Operating Mode

The mode is used: **Transmitting mode**

Frequency: 49.86MHz MHz

## 2.3 Description of Test Setup

Operation of EUT during testing



## 2.4 Measurement Instruments List

Item	Equipment	Manufacturer	Model No.	Serial No.	Last Cal.	Cal. Interval
1.	EMI Receiver	Rohde & Schwarz	ESCI	100627	Feb. 19, 2016	1 Year
2.	LISN	SchwarzBeck	NSLK 8126	8126377	Feb. 19, 2016	1 Year
3.	RF Switching Unit	Compliance Direction	RSU-M2	38303	Feb. 19, 2016	1 Year
4.	EMI Test Software ES-K1	Rohde & Schwarz	N/A	N/A	N/A	N/A
5.	EMI Test Receiver	Rohde & Schwarz	ESCI	100627	Feb. 19, 2016	1 Year
6.	Trilog Broadband Antenna	Schwarzbeck	VULB9163	VULB 9163-289	Feb. 17, 2016	1 Year
7.	Pre-amplifier	Compliance Direction	PAP-0203	22008	Feb. 19, 2016	1 Year
8.	EMI Test Software EZ-EMC	SHURPLE	N/A	N/A	N/A	N/A
9.	EMI Receiver	Rohde & Schwarz	ESCI	100627	Feb. 19, 2016	1 Year
10.	LISN	SchwarzBeck	NSLK 8126	8126377	Feb. 19, 2016	1 Year
11.	RF Switching Unit	Compliance Direction	RSU-M2	38303	Feb. 19, 2016	1 Year
12.	EMI Test Software ES-K1	Rohde & Schwarz	N/A	N/A	N/A	N/A
13.	EMI Receiver	Rohde & Schwarz	ESCI	100627	Feb. 19, 2016	1 Year
14.	EMI Receiver	Rohde & Schwarz	ESCI	100627	Feb. 19, 2016	1 Year
15.	LISN	SchwarzBeck	NSLK 8126	8126377	Feb. 19, 2016	1 Year
16.	RF Switching Unit	Compliance Direction	RSU-M2	38303	Feb. 19, 2016	1 Year
17.	EMI Test Software ES-K1	Rohde & Schwarz	N/A	N/A	N/A	N/A
18.	Programmable AC Power source	SOPH POWER	PAG-1050	630250	Feb. 26, 2016	1 Year
19.	Harmonic and Flicker Analyzer	LAPLACE	AC2000A	272629	Feb. 26, 2016	1 Year
20.	Harmonic and Flicker Test Software AC 2000A	LAPLACE	N/A	N/A	N/A	N/A
21.	ESD Simulators	KIKUSUI	KES4021	LJ003477	Feb. 19, 2016	1 Year
22.	EFT Generator	EMPEK	EFT-4040B	0430928N	Feb. 19, 2016	1 Year
23.	Shielding Room	ChangZhou ZhongYu	JB88	SEL0166	Feb. 19, 2016	1 Year
24.	Signal Generator 9KHz~2.2GHz	R&S	SML02	SEL0143	Feb. 19, 2016	1 Year
25.	Signal Generator 9KHz~1.1GHz	R&S	SML01	SEL0135	Feb. 19, 2016	1 Year
26.	Power Meter	R&S	NRVS	SEL0144	Feb. 19, 2016	1 Year
27.	RF Level Meter		URV35	SEL0137	Feb. 19, 2016	1 Year
28.	Audio Analyzer	R&S	UPL	SEL0136	Feb. 19, 2016	1 Year
29.	RF-Amplifier 150KHz~150MHz	BONN Elektronik	BSA1515-25	SEL0157	Feb. 19, 2016	1 Year
30.	Stripline Test Cell	Erika Fiedler	VDE0872	SEL0167	N/A	N/A
31.	TV Test Transmitter	R&S	SFM	SEL0159	Feb. 17, 2016	1 Year
32.	TV Generator PAL	R&S	SGPF	SEL0138	Feb. 19, 2016	1 Year
33.	TV Generator Ntsc	R&S	SGMF	SEL0140	Feb. 19, 2016	1 Year
34.	TV Generator Secam	R&S	SGSF	SEL0139	Feb. 19, 2016	1 Year

35.	TV Test Transmitter 0.3MHz~3300MHz	R&S	SFQ	SEL0142	Feb. 19, 2016	1 Year
36.	MPEG2 Measurement Generator	R&S	DVG	SEL0141	Feb. 19, 2016	1 Year
37.	Spectrum Analyzer	R&S	FSP	SEL0177	Feb. 19, 2016	1 Year
38.	Matching	R&S	RAM	SEL0146	N/A	N/A
39.	Matching	R&S	RAM	SEL0148	N/A	N/A
40.	Absorbing Clamp	R&S	MDS21	SEL0158	Feb. 19, 2016	1 Year
41.	Coupling Set	Erika Fiedler	Rco, Rci, MC, AC, LC	SEL0149	N/A	N/A
42.	Filters	Erika Fiedler	Sr, LBS	SEL0150	N/A	N/A
43.	Matching Network	Erika Fiedler	MN, T1	SEL0151	N/A	N/A
44.	Fully Anechoic Room	ChangZhou ZhongYu	854	SEL0169	Feb. 19, 2016	1 Year
45.	Signal Generator	R&S	SML03	SEL0068	Feb. 19, 2016	1 Year
46.	RF-Amplifier 30M~1GHz	Amplifier Reasearch	250W1000A	SEL0066	Oct. 24, 2015	1 Year
47.	RF-Amplifier 0.8~3.0GHz	Amplifier Reasearch	60S1G3	SEL0065	Oct. 24, 2015	1 Year
48.	Power Meter	R&S	NRVD	SEL0069	Feb. 17, 2016	1 Year
49.	Power Sensor	R&S	URV5-Z2	SEL0071	Feb. 17, 2016	1 Year
50.	Power Sensor	R&S	URV5-Z2	SEL0072	Feb. 17, 2016	1 Year
51.	Software EMC32	R&S	EMC32-S	SEL0082	N/A	N/A
52.	Log-periodic Antenna	Amplifier Reasearch	AT1080	SEL0073	N/A	N/A
53.	Antenna Tripod	Amplifier Reasearch	TP1000A	SEL0074	N/A	N/A
54.	High Gain Horn Antenna(0.8-5GHz)	Amplifier Reasearch	AT4002A	SEL0075	N/A	N/A
55.	Double-Ridged Waveguide Horn Antenna (0.8-18GHz)	ROHDE& SCHWARZ	HF907	100013	Feb. 19, 2016	1 Year
56.	Log-periodic Antenna (850MHz-26.5GHz)	ROHDE& SCHWARZ	HL050S7	100496	Feb. 19, 2016	1 Year



### 3. CONDUCTED EMISSION TEST

#### 3.1 Block Diagram of Test Setup

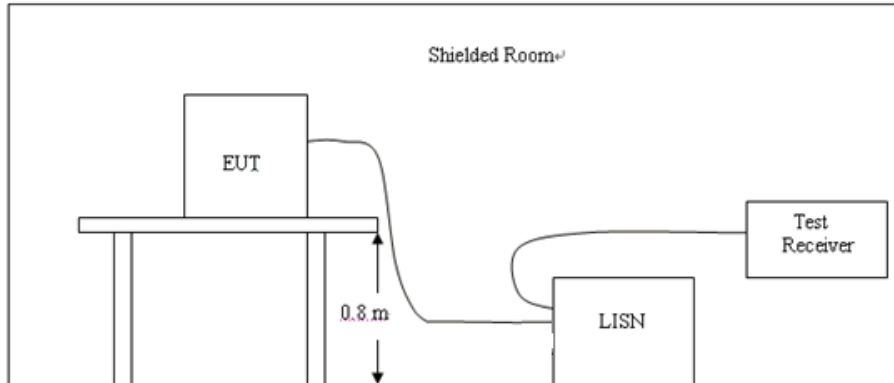

#### 3.2 Conducted Power Line Emission Limit

For unintentional device, according to § 15.207(a) Line Conducted Emission Limits is as following

Frequency of emission (MHz)	Conducted limit (dB $\mu$ V)	
	Quasi-peak	Average
0.15-0.5	66 to 56*	56 to 46*
0.5-5	56	46
5-30	60	50

\* Decreasing linearly with the logarithm of the frequency

For intentional device, according to §15.207(a) Line Conducted Emission Limit is same as above table.

#### 3.3 Test Procedure

- 1, The equipment was set up as per the test configuration to simulate typical actual usage per the user's manual. The EUT is a tabletop system, a wooden table with a height of 0.8 meters is used and is placed on the ground plane as per ANSI C63.10.
- 2, Support equipment, if needed, was placed as per ANSI C63.10.
- 3, All I/O cables were positioned to simulate typical actual usage as per ANSI C63.10.
- 4, If a EUT received DC power from the USB Port of Notebook PC, the PC's adapter received AC120V/60Hz power through a Line Impedance Stabilization Network (LISN) which supplied power source and was grounded to the ground plane.
- 5, All support equipment received AC power from a second LISN, if any.
- 6, The EUT test program was started. Emissions were measured on each current carrying line of the EUT using a spectrum Analyzer / Receiver connected to the LISN powering the EUT. The LISN has two monitoring points: Line 1 (Hot Side) and Line 2 (Neutral Side). Two scans were taken: one with Line 1 connected to Analyzer / Receiver and Line 2 connected to a 50 ohm load; the second scan had Line 1 connected to a 50 ohm load and Line 2 connected to the Analyzer / Receiver.
- 7, Analyzer / Receiver scanned from 150 KHz to 30MHz for emissions in each of the test modes

#### 3.4 Test Result

N/A (Owing to the battery operation of EUT, this test is not performed)

## 4. RADIATED EMISSION TEST

### 4.1 Block Diagram of Test Setup

#### (1) Radiated Emission Test-Up Frequency Below 30MHz

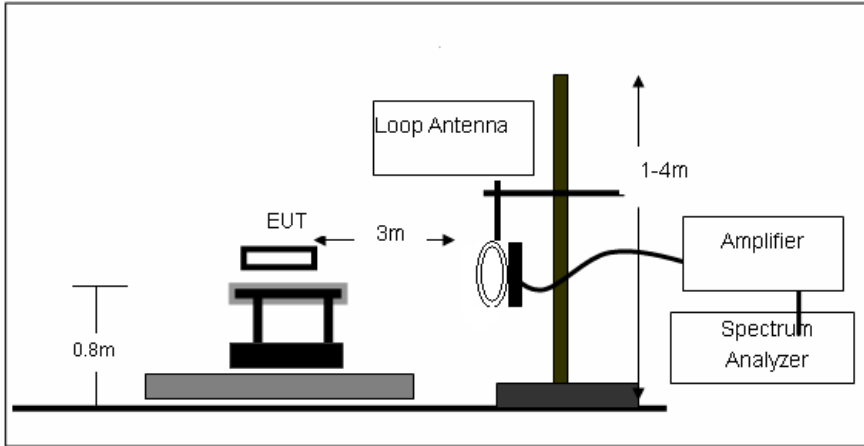

#### (2) Radiated Emission Test-Up Frequency 30MHz~1GHz

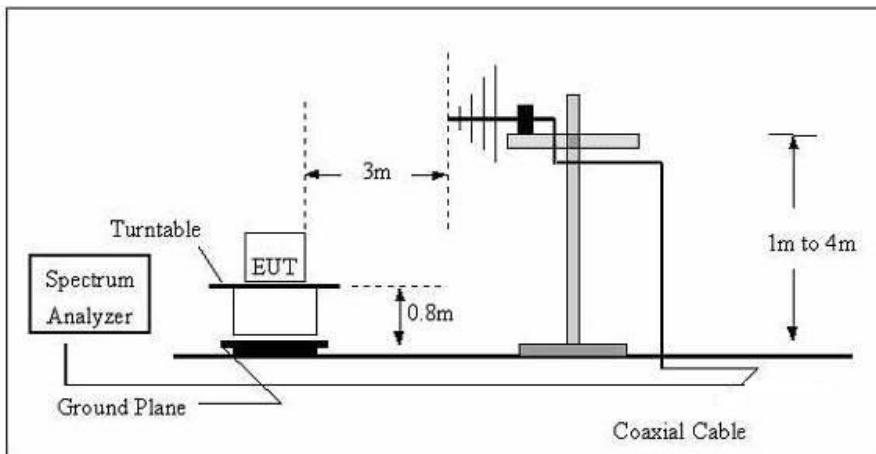

#### (3) Radiated Emission Test-Up Frequency Above 1GHz

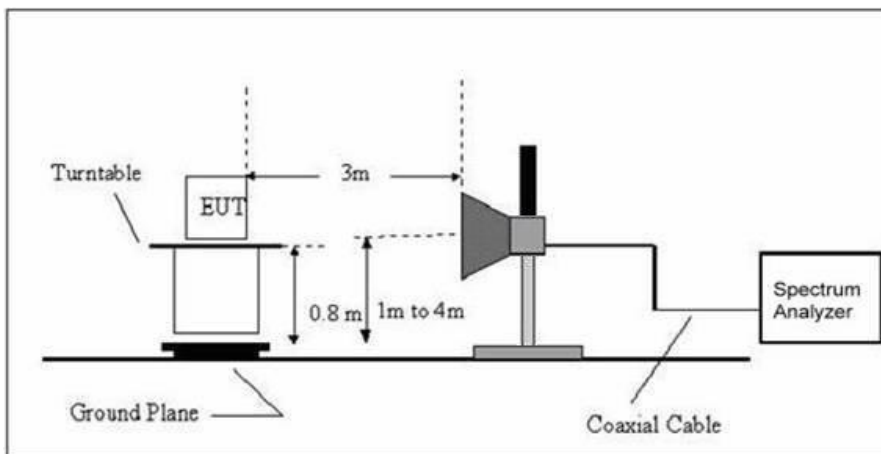

## 4.2 Limits

FREQUENCY MHz	DISTANCE Meters	FIELD STRENGTHS LIMIT	
		μV/m	dB(μV)/m
49.860 MHz Fundamental Frequency	3	$10 \times 10^3$	80.0
30 ~ 88	3	100	40.0
88 ~ 216	3	150	43.5
216 ~ 960	3	200	46.0
Above 960	3	500	54.0

Note: (1) Emission level (dB) uV = 20 log Emission level uV/m  
 (2) The smaller limit shall apply at the cross point between two frequency bands.  
 (3) Distance is the distance in meters between the measuring instrument, antenna and the closest point of any part of the device or system.

## 4.3 Test Procedure

1. The EUT is placed on a turntable, which is 0.8m above ground plane.
2. The turntable shall be rotated for 360 degrees to determine the position of maximum emission level.
3. EUT is set 3m away from the receiving antenna, which is varied from 1m to 4m to find out the highest emissions.
4. Maximum procedure was performed on the six highest emissions to ensure EUT compliance.
5. And also, each emission was to be maximized by changing the polarization of receiving antenna both horizontal and vertical.
6. Repeat above procedures until the measurements for all frequencies are complete.
7. Based on the Frequency Generator in the device include 49.86MHz. The test frequency range from 9KHz to 25GHz per FCC PART 15.33(a).

## 4.4 Test Result PASS

All the emissions except fundamental emission from 9KHz to 1GHz were comply with 15.209 limit.

Note1: According exploratory test no any obvious emission were detected from 9KHz to 30MHz, so the final test was performed with frequency range from 25MHz to 1GHz and recorded in below.

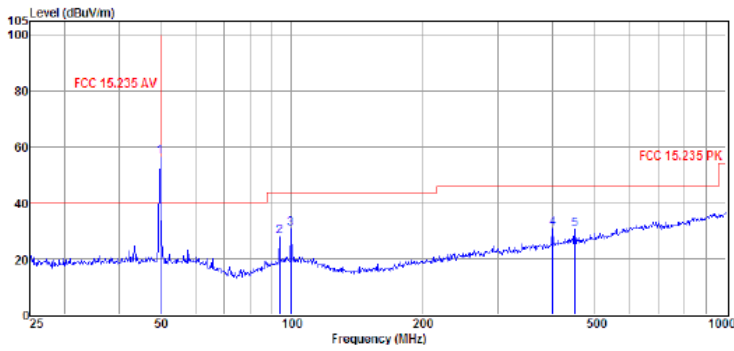

Item (Mark)	Freq (MHz)	Read Level (dBuV)	Antenna Factor (dB/m)	Cable Loss (dB)	Result Level (dBuV/m)	Limit Line (dBuV/m)	Over Limit (dB)	Detector	Polarization
1	49.86	40.45	12.02	3.89	56.36	100.00	-43.64	Peak	VERTICAL
2	93.99	12.27	11.42	4.25	27.94	43.50	-15.56	Peak	VERTICAL
3	99.70	14.28	11.98	4.30	30.56	43.50	-12.94	Peak	VERTICAL
4	399.11	9.32	15.68	5.80	30.80	46.00	-15.20	Peak	VERTICAL
5	449.11	8.10	16.32	5.98	30.40	46.00	-15.60	Peak	VERTICAL

Note: 1. Result Level = Read Level + Antenna Factor + Cable loss.  
 2. If Peak Result complies with QP limit, QP Result is deemed to comply with QP limit.  
 3. Test setup: RBW: 120 kHz, VBW: 300 kHz, Sweep time: auto.

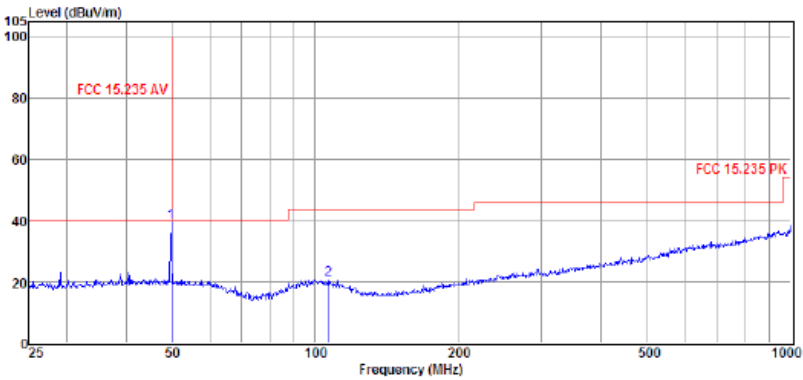

Item (Mark)	Freq (MHz)	Read Level (dBuV)	Antenna Factor (dB/m)	Cable Loss (dB)	Result Level (dBuV/m)	Limit Line (dBuV/m)	Over Limit (dB)	Detector	Polarization
1	49.86	23.42	12.02	3.89	39.33	100.00	-60.67	Peak	HORIZONTAL
2	106.94	5.00	11.36	4.34	20.70	43.50	-22.80	Peak	HORIZONTAL

Note: 1. Result Level = Read Level + Antenna Factor + Cable loss.  
 2. If Peak Result complies with QP limit, QP Result is deemed to comply with QP limit.  
 3. Test setup: RBW: 120 kHz, VBW: 300 kHz, Sweep time: auto.

## 6. OCCUPIED BANDWIDTH MEASUREMENT

### 6.1 Block Diagram of Test Setup

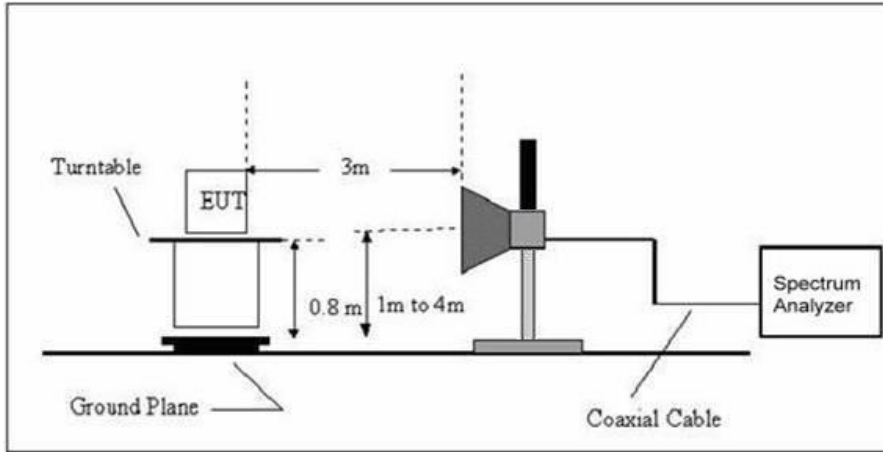

### 6.2 Test Procedure

- 1, The field strength of any emission which appear outside of the band shall not exceed the general radiated emission limits in section 15.209.
- 2, The useful radiated emission from the EUT was detected by the spectrum analyzer with peak detector.
- 3, The result has been complied with the 15.235.

### 6.3 Test Result

PASS

The graph as below.

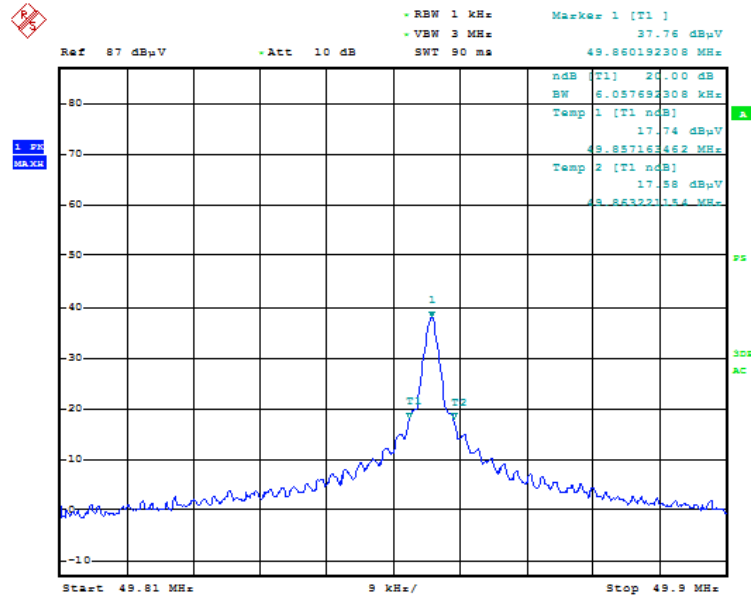

## 7. ANTENNA REQUIREMENT

According to Section 15.203, an intentional radiator shall be designed to ensure that no antenna other than that furnished by the responsible party shall be used with the device. Antenna is fixed by enclosure, can not be changed except take apart the product.

Antenna

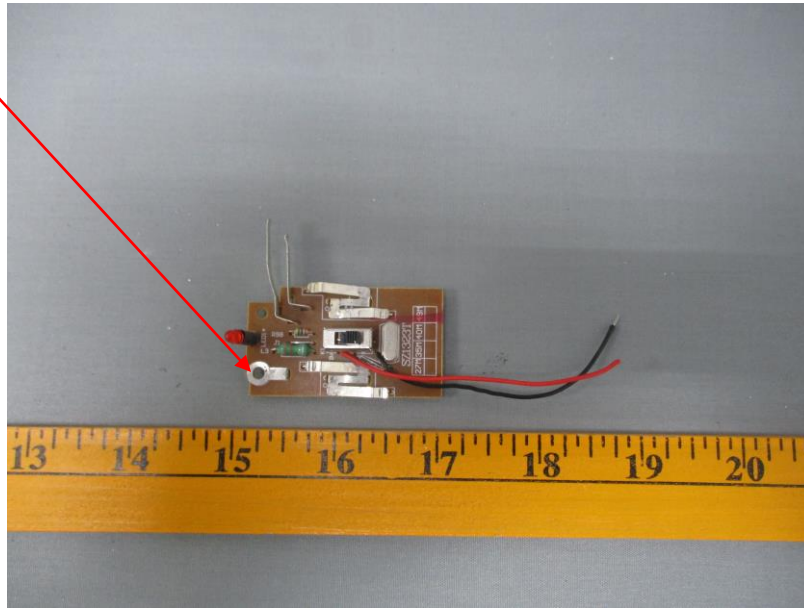

8. PHOTOGRAPH OF TEST

Radiated Emission

