

RF Test Report

Project Number: 4511904**Proposal Number: 9420****Report Number: 4511904EMC06****Revision Level: 0****Client: Owlet Baby Care Inc.****Equipment Under Test: Owlet Band****Model / HVIN: OBB 1.0****FCC ID: 2AIEP-OBB1A****IC: 21386-OBB1A****Applicable Standards: FCC Part 15 Subpart C, § 15.247****RSS-247, Issue 2****RSS-GEN, Issue 5****ANSI C63.10:2013****Report issued on: 15 November 2019****Test Result: Compliant**

Tested by:

Aaron S. Froehlich, EMC Test Engineer

Reviewed by:

David Schramm, Operations Manager

Remarks: This report details the results of the testing carried out on one sample, the results contained in this test report do not relate to other samples of the same product. The manufacturer should ensure that all products in series production are in conformity with the product sample detailed in this report.

This document is issued by the Company under its General Conditions of Service accessible at <http://www.sgs.com/en/Terms-and-Conditions.aspx>. Attention is drawn to the limitation of liability, indemnification and jurisdiction issues defined therein.

Any holder of this document is advised that information contained hereon reflects the Company's findings at the time of its intervention only and within the limits of Client's instructions, if any. The Company's sole responsibility is to its Client and this document does not exonerate parties to a transaction from exercising all their rights and obligations under the transaction documents. Any unauthorized alteration, forgery or falsification of the content or appearance of this document is unlawful and offenders may be prosecuted to the fullest extent of the law.

Table of Contents

1	SUMMARY OF TEST RESULTS	4
1.1	MODIFICATIONS REQUIRED FOR COMPLIANCE	4
2	GENERAL INFORMATION	5
2.1	CLIENT INFORMATION	5
2.2	TEST LABORATORY	5
2.3	GENERAL INFORMATION OF EUT	5
2.4	OPERATING MODES AND CONDITIONS	5
2.5	EUT CONNECTION BLOCK DIAGRAM(S)	6
2.6	SYSTEM CONFIGURATIONS	6
2.7	CABLE LIST	6
3	BANDWIDTH	7
3.1	TEST RESULT	7
3.2	TEST METHODS	7
3.3	TEST SITE	7
3.4	TEST EQUIPMENT	7
3.5	TEST DATA – DTS BANDWIDTH (6dB)	8
3.6	TEST DATA – 99% OCCUPIED BANDWIDTH.....	9
4	OUTPUT POWER	10
4.1	TEST RESULT.....	10
4.2	TEST METHOD.....	10
4.3	TEST SITE	10
4.4	TEST EQUIPMENT	10
4.5	TEST DATA.....	10
5	POWER SPECTRAL DENSITY	11
5.1	TEST RESULT	11
5.2	TEST METHOD.....	11
5.3	TEST SITE	11
5.4	TEST EQUIPMENT	11
5.5	TEST DATA.....	12
6	CONDUCTED SPURIOUS EMISSIONS / BAND EDGE	13
6.1	TEST RESULT.....	13
6.2	TEST METHOD.....	13
6.3	TEST SITE	13
6.4	TEST EQUIPMENT	13
6.5	TEST DATA – DTS BAND EDGE.....	14
6.6	TEST DATA – CONDUCTED SPURIOUS EMISSIONS	15
7	EMISSIONS IN RESTRICTED FREQUENCY BANDS	16
7.1	TEST RESULT.....	16
7.2	TEST METHOD.....	16
7.3	TEST SITE	16
7.4	TEST EQUIPMENT	17
7.5	TEST DATA.....	18
8	BAND EDGE EMISSIONS IN RESTRICTED FREQUENCY BANDS	23
8.1	TEST RESULT.....	23
8.2	TEST METHOD.....	23
8.3	TEST SITE	23



8.4 TEST EQUIPMENT 23

8.5 TEST DATA..... 24

9 AC POWERLINE CONDUCTED EMISSIONS..... 25

9.1 TEST RESULT..... 25

9.2 TEST METHOD..... 25

9.3 TEST SITE..... 25

9.4 TEST EQUIPMENT 25

9.5 TEST DATA..... 26

10 MEASUREMENT UNCERTAINTY..... 28

11 REVISION HISTORY 29

1 Summary of Test Results

Test Description	Test Specification		Test Result
Bandwidth	15.247(a)(2)	RSS-247 S5.2 (a) RSS-GEN S6.7	Compliant
Output Power	15.247(b)(3)	RSS-247 S5.4 (d)	Compliant
Power Spectral Density	15.247(e)	RSS-247 S5.2 (b)	Compliant
Conducted Spurious Emissions / Band Edge	15.247(d)	RSS-247 S5.5	Compliant
Emissions in Restricted Frequency Bands	15.247(d) 15.205, 15.209	RSS-247 S5.5 RSS-GEN S8.9, S8.10	Compliant
Band Edge Emissions in Restricted Frequency Bands	15.205, 15.209	RSS-GEN S8.9, S8.10	Compliant
AC Powerline Conducted Emissions	15.207	RSS-GEN S8.8	Compliant
Antenna Requirement	15.203	RSS-GEN S6.8	Compliant ¹

(1) Device uses an internal chip antenna which cannot be replaced by the end user.

1.1 Modifications Required for Compliance

None

2 General Information

2.1 Client Information

Name: Owlet Baby Care Inc.
Address: 2500 Executive Parkway Suite 500
City, State, Zip, Country: Lehi, UT 84043

2.2 Test Laboratory

Name: SGS North America, Inc.
Address: 620 Old Peachtree Road NW, Suite 100
City, State, Zip, Country: Suwanee, GA 30024, USA

Accrediting Body: A2LA
Type of lab: Testing Laboratory
Certificate Number: 3212.01

2.3 General Information of EUT

Type of Product: Pregnancy Wearable Device
Model: OBB 1.0
Firmware Version ID Number: V1
Serial Number: NSN

FCC ID: 2AIEP-OBB1A
IC: 21386-OBB1A

Frequency Range: 2402-2480 MHz
Data Modes: GFSK (Bluetooth Low Energy)
Antenna P/N: 2450AT07A0100
Antenna Type: Chip
Antenna Pk Gain: 1.0 dBi

DUT Rated Voltage: 3.7 Vdc (Battery)
DUT Test Voltage: 3.7 Vdc (Battery)
Charging Station Rated Voltage: 5 Vdc (USB)
Charging Station Test Voltage: 5 Vdc (USB)

Sample Received Date: 14 Oct 2019
Dates of testing: 14 – 17 Oct 2019

2.4 Operating Modes and Conditions

The DUT was configured to transmit continuously on low mid and high channels at maximum power and duty cycle. The Chip antenna was connected during Emissions in Restricted Frequency Bands and AC Powerline Conducted Emissions tests. All other tests were performed using antenna port conducted methods.

Pretest investigations were performed to determine that the “worst case” mode of operations was while docked on the charging station. The USB / UART connection with the support laptop is beyond the scope of this investigation as it is not present in real world operations. Ferrite beads were used to suppress possible emissions from this connection.

2.5 EUT Connection Block Diagram(s)

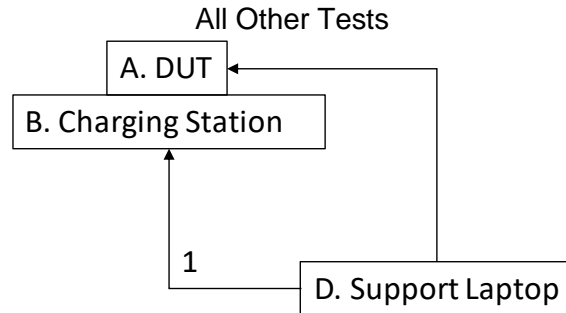
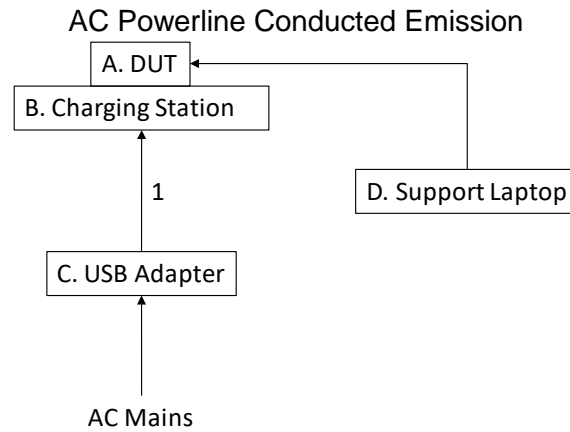

2.6 System Configurations

Device Reference	Manufacturer	Description	Model Number	Serial Number
A	Owlet Baby Care Inc.	Medallion	OBB 1.0	NSN
B	Owlet Baby Care Inc.	Charging Station	OBB 1.0	NSN
C	Samsung	Travel Adapter	EP-TA20JWE	R37G5AM1B52SE3
D	Lenovo	Laptop	ThinkPad T420	4236B85

2.7 Cable List

Cable reference	Port Name	Start	End	Cable Length (m)	Ferrite installed?	Shielded?
1	USB	Charging Station	Support Laptop	1.0	N	Y

3 Bandwidth

3.1 Test Result

Test Description	Test Specification		Test Result
DTS Bandwidth (6dB)	15.247(a)(2)	RSS-247 S5.2 (a)	Compliant
Occupied Bandwidth (99%)		RSS-GEN S6.7	Reported

3.2 Test Methods

The DTS 6dB bandwidth measurements were performed using the procedure from ANSI C63.10 clause 11.8.1, and the 99% occupied bandwidth measurements were performed using the procedure from ANSI C63.10 clause 6.9.3.

Limit

The minimum 6dB bandwidth shall be at least 500 kHz.

3.3 Test Site

SGS EMC Laboratory, Suwanee, GA

Environmental Conditions

Temperature: 23.5 °C

Relative Humidity: 47.3 %

Atmospheric Pressure: 98.1 kPa

3.4 Test Equipment

Test End Date: 14-Oct-2019

Tester: ASF

Equipment	Model	Manufacturer	Asset Number	Cal Due Date
RF CABLE (TS8997)	141	HUBER & SUHNER	B095585	6-Sep-2020
ATTENUATOR, 10DB (TS8997)	10DB	ROHDE & SCHWARZ	B095591	7-Sep-2020
RF SWITCH (TS8997)	OSP	ROHDE & SCHWARZ	15039	8-Feb-2020
SIGNAL ANALYZER (TS8997)	FSV30	ROHDE & SCHWARZ	B085749	1-Nov-2019

Note: The equipment calibration period is 1 year except for the FSV which is on a 2-year cycle.

3.5 Test Data – DTS Bandwidth (6dB)

DUT Frequency(MHz)	Bandwidth(MHz)	Limit Min(MHz)	Limit Max(MHz)	Band Edge Left(MHz)	Band Edge Right(MHz)
2402	0.712872	0.5	---	2401.762376	2402.475248
2440	0.712872	0.5	---	2439.762376	2440.475248
2480	0.712872	0.5	---	2479.762376	2480.475248

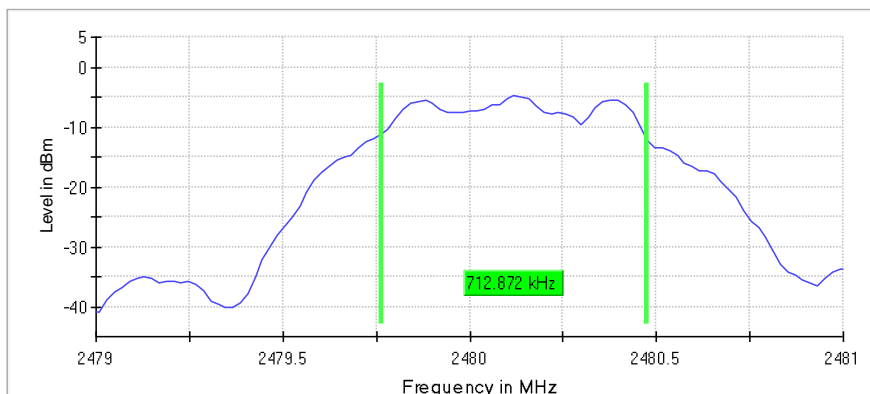
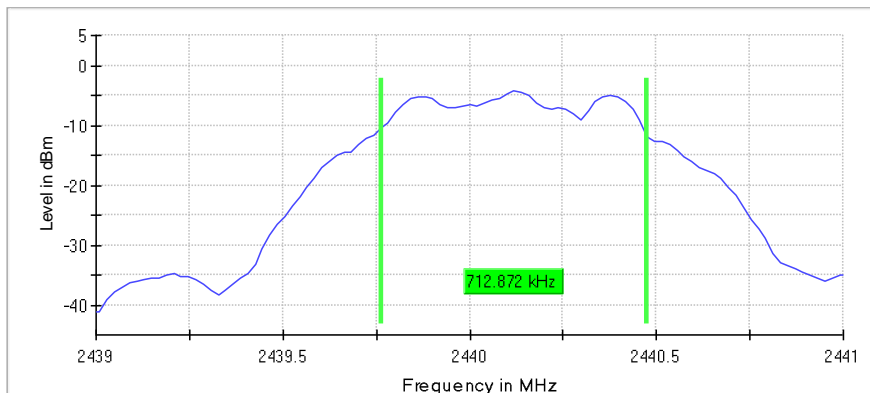
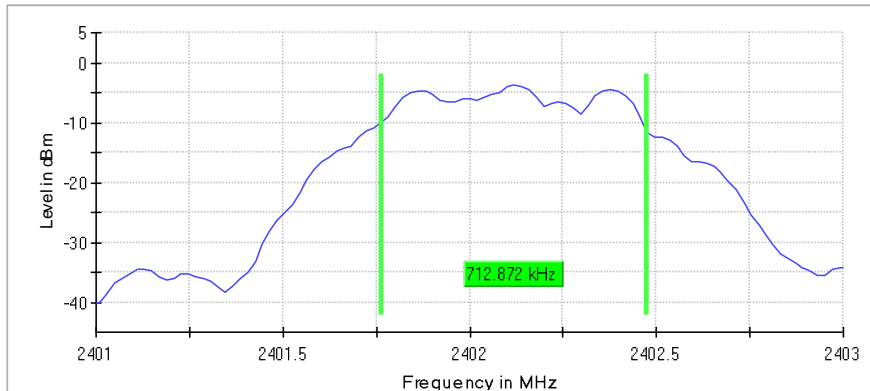

3.6 Test Data – 99% Occupied Bandwidth

DUT Frequency(MHz)	Bandwidth(MHz)	Limit Min(MHz)	Limit Max(MHz)	Band Edge Left(MHz)	Band Edge Right(MHz)
2402	1.04	---	---	2401.6125	2402.6525
2440	1.04	---	---	2439.6125	2440.6525
2480	1.04	---	---	2479.6175	2480.6575

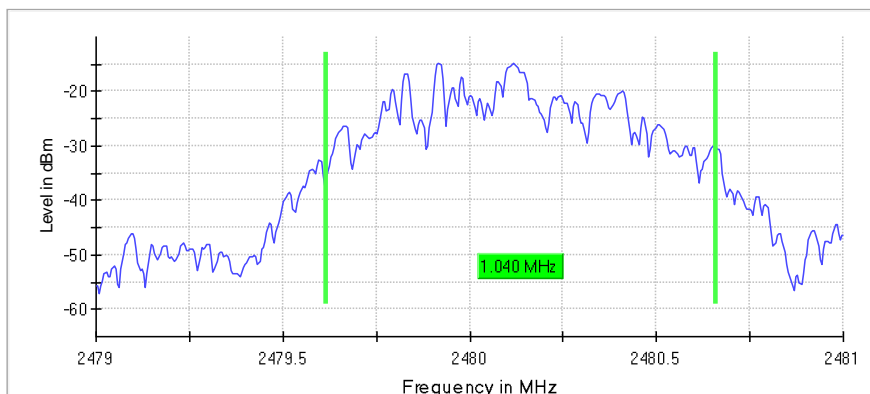
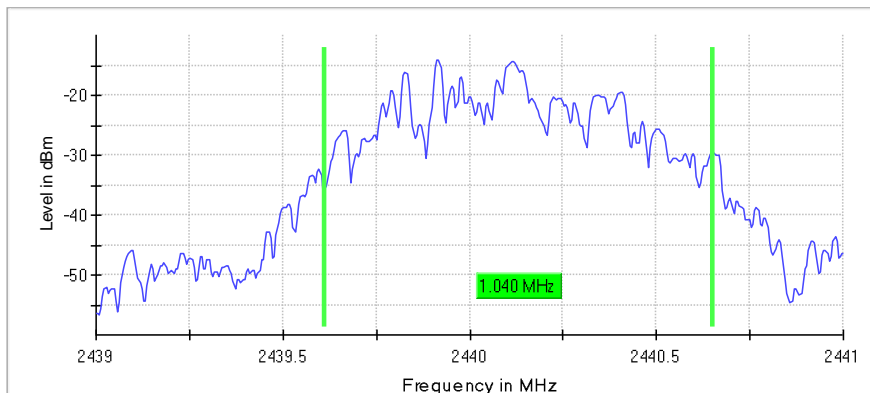
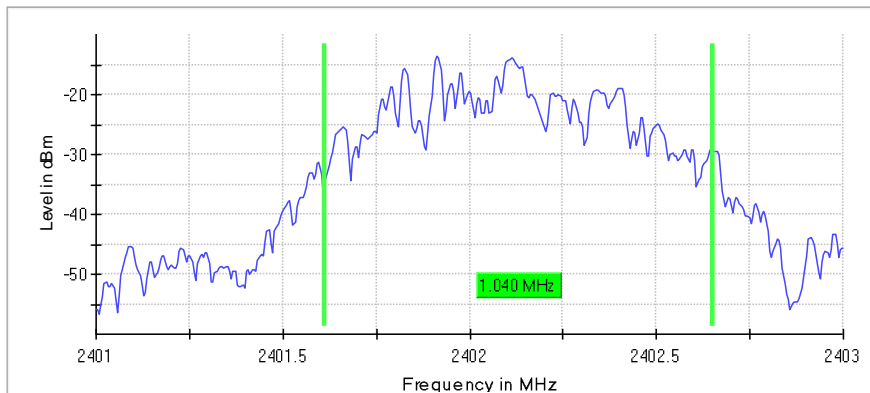

4 Output Power

4.1 Test Result

Test Description	Test Specification		Test Result
Fundamental Emission Output Power	15.247(b)(3)	RSS-247 S5.4 (d)	Compliant

4.2 Test Method

Fundamental maximum conducted (average) output power measurements were performed using the method described in ANSI C63.10:2013 clause 11.9.2.3.2. This method uses a wideband gated RF power meter with gate parameters adjusted such that the power is measured only when the EUT is transmitting at its maximum power control level. Because the measurement is made only during the ON time of the transmitter, no duty cycle correction factor is required.

Limit

For systems using digital modulation in the 902-928 MHz, 2400-2483.5 MHz, and 5725-5850 MHz bands: 1 Watt. For using antennas with greater than 6dBi of gain, the limit is reduced in dB by the amount the gain exceeds 6dBi (e.g. for a 7.4dBi antenna, the limit is reduced from 30dBm to 28.6dBm). Also, the e.i.r.p. shall not exceed 4 Watts (36 dBm) based on RSS-247 S5.4 (d).

4.3 Test Site

SGS EMC Laboratory, Suwanee, GA

Environmental Conditions

Temperature: 23.5 °C
 Relative Humidity: 47.3 %
 Atmospheric Pressure: 98.1 kPa

4.4 Test Equipment

Test End Date: 14-Oct-2019

Tester: ASF

Equipment	Model	Manufacturer	Asset Number	Cal Due Date
RF CABLE (TS8997)	141	HUBER & SUHNER	B095585	6-Sep-2020
ATTENUATOR, 10DB (TS8997)	10DB	ROHDE & SCHWARZ	B095591	7-Sep-2020
RF SWITCH (TS8997)	OSP	ROHDE & SCHWARZ	15039	8-Feb-2020
SIGNAL ANALYZER (TS8997)	FSV30	ROHDE & SCHWARZ	B085749	1-Nov-2019
POWER METER (TS8997)	OSP-B157	ROHDE & SCHWARZ	15040	8-Feb-2020

Note: The equipment calibration period is 1 year except for the FSV which is on a 2-year cycle.

4.5 Test Data

DUT Frequency(MHz)	Gated RMS(dBm)	Limit Max(dBm)	DutyCycle(%)	Result
2402	-3.6	30	17.075	PASS
2440	-4.1	30	17.075	PASS
2480	-4.5	30	17.074	PASS

5 Power Spectral Density

5.1 Test Result

Test Description	Test Specification		Test Result
Power Spectral Density	15.247(e)	RSS-247 S5.2 (b)	Compliant

5.2 Test Method

Power spectral density measurements were performed using the procedures from ANSI C63.10: 2013 clause 11.10.7.

Limit

The maximum limit is 8 dBm / 3 kHz.

5.3 Test Site

SGS EMC Laboratory, Suwanee, GA

Environmental Conditions

Temperature: 23.5 °C

Relative Humidity: 47.3 %

Atmospheric Pressure: 98.1 kPa

5.4 Test Equipment

Test End Date: 14-Oct-2019

Tester: ASF

Equipment	Model	Manufacturer	Asset Number	Cal Due Date
RF CABLE (TS8997)	141	HUBER & SUHNER	B095585	6-Sep-2020
ATTENUATOR, 10DB (TS8997)	10DB	ROHDE & SCHWARZ	B095591	7-Sep-2020
RF SWITCH (TS8997)	OSP	ROHDE & SCHWARZ	15039	8-Feb-2020
SIGNAL ANALYZER (TS8997)	FSV30	ROHDE & SCHWARZ	B085749	1-Nov-2019
POWER METER (TS8997)	OSP-B157	ROHDE & SCHWARZ	15040	8-Feb-2020

Note: The equipment calibration period is 1 year except for the FSV which is on a 2-year cycle.

5.5 Test Data

DUT Frequency(MHz)	Frequency(MHz)	PSD(dBm)	Limit Max(dBm)	Result
2402	2401.9125	-14.318	8	PASS
2440	2440.1125	-14.475	8	PASS
2480	2480.1225	-15.404	8	PASS

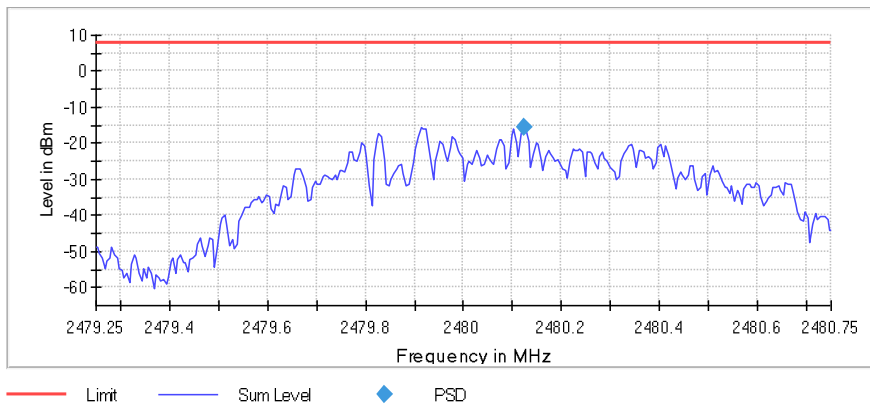
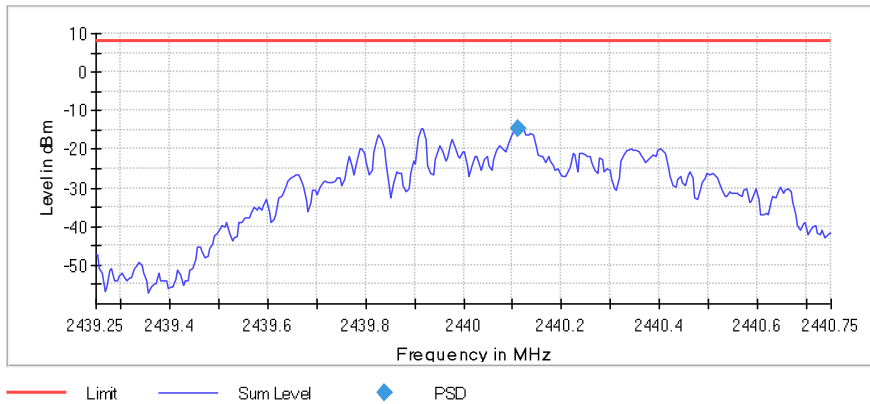
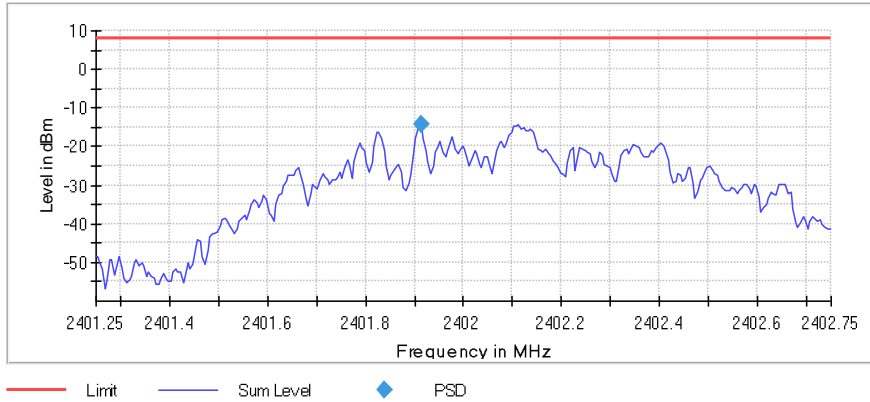

6 Conducted Spurious Emissions / Band Edge

6.1 Test Result

Test Description	Test Specification		Test Result
Conducted Spurious and Band Edge Emissions	15.247(d)	RSS-247 S5.5	Compliant

6.2 Test Method

Conducted band edge and spurious band emissions in non-restricted frequency bands were measured using the method defined in ANSI C63.10 clause 11.11.

Limit

Because the maximum conducted average output power was used to determine compliance with the output power limits, the limit in any 100 kHz band outside of the authorized band is 30 dB below the maximum in-band peak level.

6.3 Test Site

SGS EMC Laboratory, Suwanee, GA

Environmental Conditions

	14 Oct 2019	17 Oct 2019
Temperature:	23.5 °C	26.0 °C
Relative Humidity:	47.3 %	32.3 %
Atmospheric Pressure:	98.1 kPa	97.5 kPa

6.4 Test Equipment

DTS Band Edge:

Test End Date: 14-Oct-2019

Tester: ASF

Equipment	Model	Manufacturer	Asset Number	Cal Due Date
RF CABLE (TS8997)	141	HUBER & SUHNER	B095585	6-Sep-2020
ATTENUATOR, 10DB (TS8997)	10DB	ROHDE & SCHWARZ	B095591	7-Sep-2020
RF SWITCH (TS8997)	OSP	ROHDE & SCHWARZ	15039	8-Feb-2020
SIGNAL ANALYZER (TS8997)	FSV30	ROHDE & SCHWARZ	B085749	1-Nov-2019
POWER METER (TS8997)	OSP-B157	ROHDE & SCHWARZ	15040	8-Feb-2020

Note: The equipment calibration period is 1 year except for the FSV which is on a 2-year cycle.

Conducted Spurious Emissions:

Test End Date: 17-Oct-2019

Tester: ASF

Equipment	Model	Manufacturer	Asset Number	Cal Due Date
RF CABLE	SF102	HUBER & SUHNER	B079824	17-Jul-2020
EMI TEST RECEIVER	ESU40	ROHDE & SCHWARZ	B079629	1-Aug-2020

Note: The equipment calibration period is 1 year.

6.5 Test Data – DTS Band Edge

BLE - Lower band edge

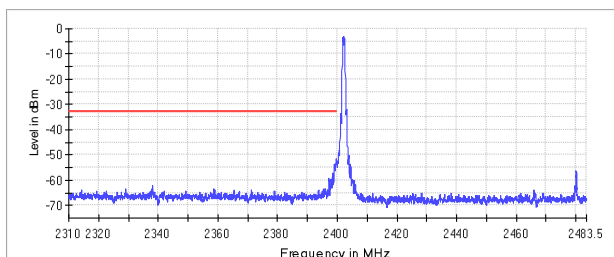

— Limit — Sum Level × Fail

Frequency(MHz)	Level(dBm)	Margin(dB)	Limit(dBm)	Result
2399.575	-51.4	18.6	-32.8	PASS
2399.525	-51.4	18.6	-32.8	PASS
2399.625	-51.7	18.9	-32.8	PASS
2399.675	-52.2	19.4	-32.8	PASS
2399.475	-52.4	19.6	-32.8	PASS
2399.725	-52.4	19.6	-32.8	PASS
2399.775	-52.5	19.7	-32.8	PASS
2399.975	-53.1	20.3	-32.8	PASS
2399.825	-53.4	20.6	-32.8	PASS
2399.125	-53.9	21.1	-32.8	PASS
2399.075	-53.9	21.1	-32.8	PASS
2399.925	-54.3	21.5	-32.8	PASS
2399.425	-54.5	21.7	-32.8	PASS
2399.175	-54.6	21.8	-32.8	PASS
2399.025	-54.7	21.9	-32.8	PASS

BLE - Upper band edge

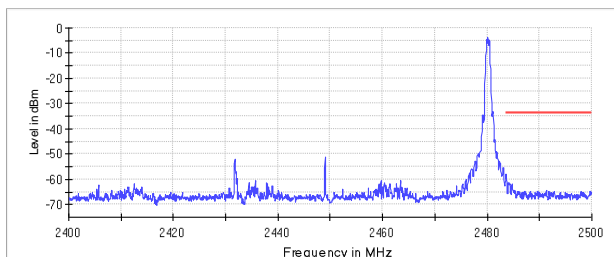

— Limit — Sum Level × Fail

Frequency(MHz)	Level(dBm)	Margin(dB)	Limit(dBm)	Result
2483.575	-57.9	24	-33.9	PASS
2483.525	-58.1	24.2	-33.9	PASS
2483.625	-58.4	24.5	-33.9	PASS
2483.675	-59.9	26	-33.9	PASS
2483.725	-61	27.1	-33.9	PASS
2484.125	-61.2	27.3	-33.9	PASS
2484.175	-61.3	27.4	-33.9	PASS
2484.075	-61.4	27.5	-33.9	PASS
2484.775	-61.8	27.9	-33.9	PASS
2484.725	-61.8	27.9	-33.9	PASS
2484.025	-61.9	28	-33.9	PASS
2484.325	-62	28.1	-33.9	PASS
2484.225	-62.1	28.2	-33.9	PASS
2484.375	-62.1	28.2	-33.9	PASS
2483.775	-62.2	28.3	-33.9	PASS

6.6 Test Data – Conducted Spurious Emissions

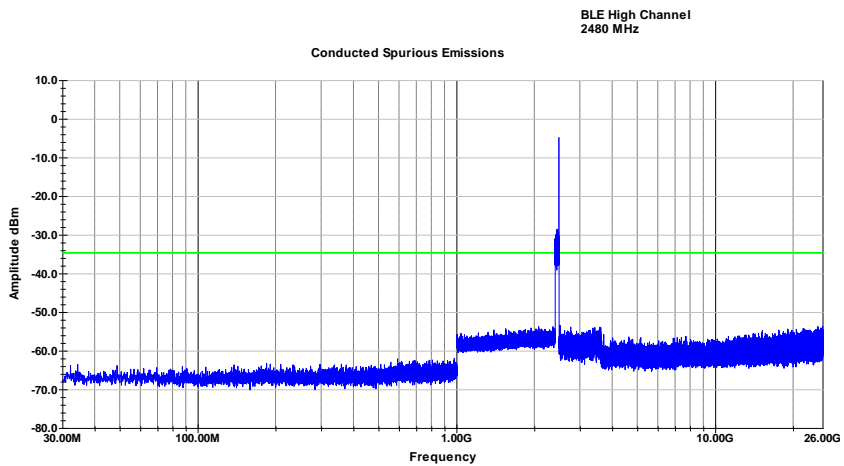
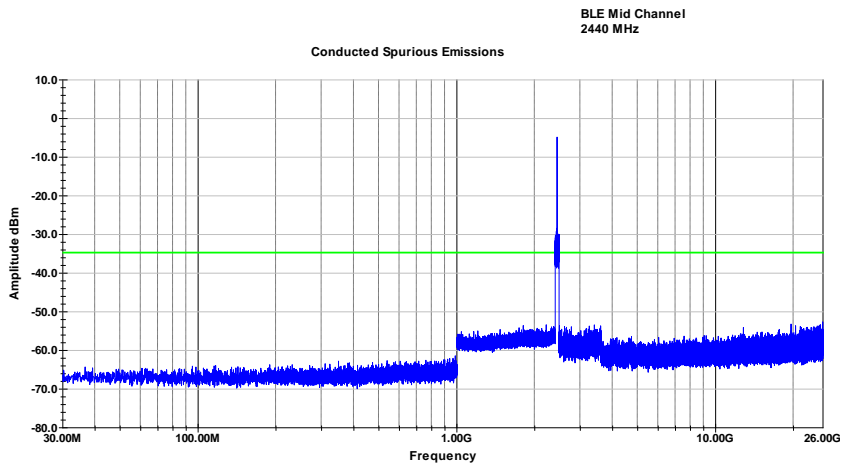
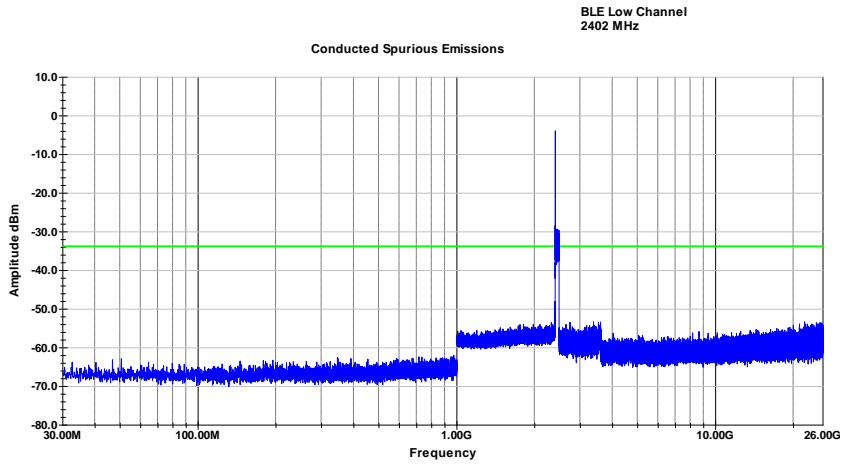

7 Emissions in Restricted Frequency Bands

7.1 Test Result

Test Description	Test Specification		Test Result
Emissions in Restricted Frequency Bands	15.247(d) 15.205, 15.209	RSS-247 S5.5 RSS-GEN S8.9, S8.10	Compliant

7.2 Test Method

The radiated methods of ANSI C63.10 Clause 11.12.1 were used to demonstrate compliance. Lowest, middle and highest channels were investigated – the device was commanded to continuously transmit with the integral chip antenna connected. The worst case datum of three orthogonal directions has been reported.

Test distances for radiated tests:

- 9k to 30 MHz – Near field prescan to determine if there were any emissions
- 30 to 1000 MHz - The EUT to measurement antenna distance was 3 meters
- 1 to 18 GHz - The EUT to measurement antenna distance was 3 meters
- 18 to 26 GHz - The EUT to measurement antenna distance was 3 meters

Limits within restricted bands of operation:

Frequency	Limits ⁽¹⁾		Peak Limits dBuV/m
	Microvolts/m	dBuV/m	
30 - 88 MHz	100	40 ⁽²⁾	--
88 - 216 MHz	150	43.5 ⁽²⁾	--
216 - 960 MHz	200	46 ⁽²⁾	--
960 - 1000 MHz	500	54 ⁽²⁾	--
1 - 40 GHz	500	54 ⁽³⁾	74

(1) These limits are applicable to emissions outside of the intentional transmit frequency band.

(2) Quasi-peak limit

(3) Average limit

7.3 Test Site

SGS EMC Laboratory, Suwanee, GA

Environmental Conditions

Temperature: 24.4 °C

Relative Humidity: 46.4 %

Atmospheric Pressure: 97.2 kPa

7.4 Test Equipment

Test End Date: 16-Oct-2019

Tester: ASF

Equipment	Model	Manufacturer	Asset Number	Cal Due Date
ANTENNA, DRG HORN (MEDIUM)	3117	ETS LINDGREN	B079691	10-Aug-2020
RF CABLE	SF102	HUBER & SUHNER	B079822	17-Jul-2020
LOW NOISE AMPLIFIER	TS-PR18	ROHDE & SCHWARZ	15003	24-Jan-2020
RF CABLE	SUCOFLEX 100	HUBER & SUHNER	B108523	5-Sep-2020
EMI TEST RECEIVER	ESU40	ROHDE & SCHWARZ	B079629	1-Aug-2020
ANTENNA, BILOG	JB6	SUNOL	B079690	11-Dec-2020
RF CABLE	SF106	HUBER & SUHNER	B079712	5-Sep-2020
RF CABLE	SF106	HUBER & SUHNER	B079713	7-Sep-2020
RF CABLE	SF106	HUBER & SUHNER	B079659	5-Sep-2020

Note: The equipment calibration period is 1 year.

7.5 Test Data

No emissions were detected in the 9kHz to 30MHz frequency range.

7.5.1 30-1000 MHz

There was no significant deviation in emissions below 1 GHz based on axis or channel

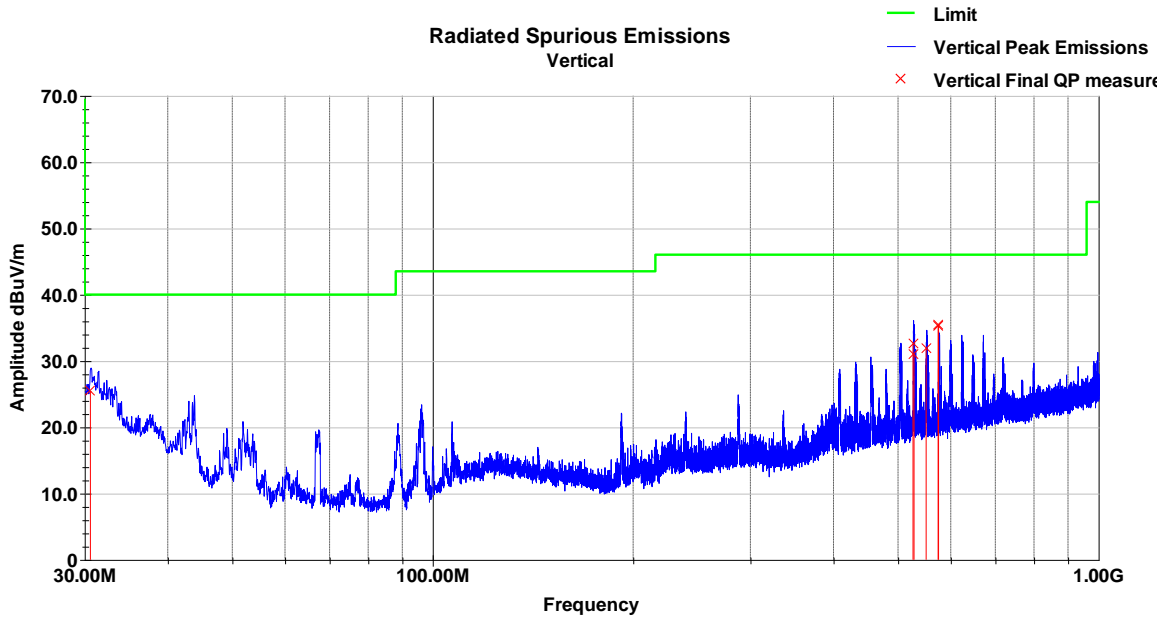

Frequency MHz	Raw QP (dBuV)	Polarity (V/H)	Azimuth (degrees)	Height (cm)	AF (dB/m)	Loss (dB)	Amp (dB)	QP Value (dBuV/m)	Limit (dBuV/m)	Margin (dB)
30.61	34.8	V	246.0	214.0	21.7	0.6	31.6	25.4	40.0	-14.6
526.61	45.8	V	98.0	199.0	18.7	2.7	34.6	32.6	46.0	-13.4
528.31	44.2	V	91.0	224.0	18.7	2.7	34.6	31.0	46.0	-15.0
551.06	45.0	V	74.0	196.0	18.7	2.8	34.6	31.9	46.0	-14.2
574.30	47.6	V	81.0	174.0	19.5	2.8	34.6	35.4	46.0	-10.6
575.12	47.5	V	84.0	177.0	19.5	2.8	34.5	35.2	46.0	-10.8
QP Value = Level + AF + CL - Amp										
Margin = QP Value - Limit										

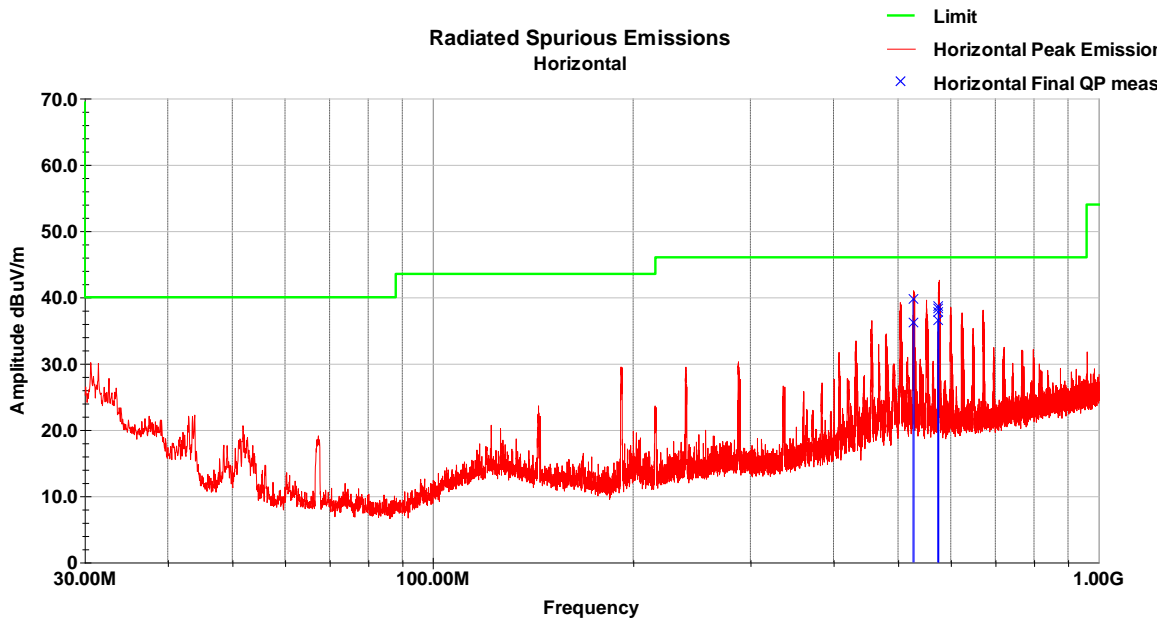

Frequency MHz	Raw QP (dBuV)	Polarity (V/H)	Azimuth (degrees)	Height (cm)	AF (dB/m)	Loss (dB)	Amp (dB)	QP Value (dBuV/m)	Limit (dBuV/m)	Margin (dB)
526.60	52.8	H	336.0	186.0	18.7	2.7	34.6	39.6	46.0	-6.4
528.32	49.3	H	335.0	169.0	18.7	2.7	34.6	36.1	46.0	-9.9
573.73	48.8	H	49.0	179.0	19.5	2.8	34.6	36.5	46.0	-9.5
574.66	50.6	H	48.0	195.0	19.5	2.8	34.6	38.3	46.0	-7.7
575.13	50.9	H	39.0	171.0	19.5	2.8	34.5	38.7	46.0	-7.4
575.56	50.0	H	48.0	170.0	19.4	2.8	34.5	37.7	46.0	-8.3
QP Value = Level + AF + CL - Amp										
Margin = QP Value - Limit										

7.5.2 1-18 GHz

There were no harmonic emissions detected above 1 GHz.

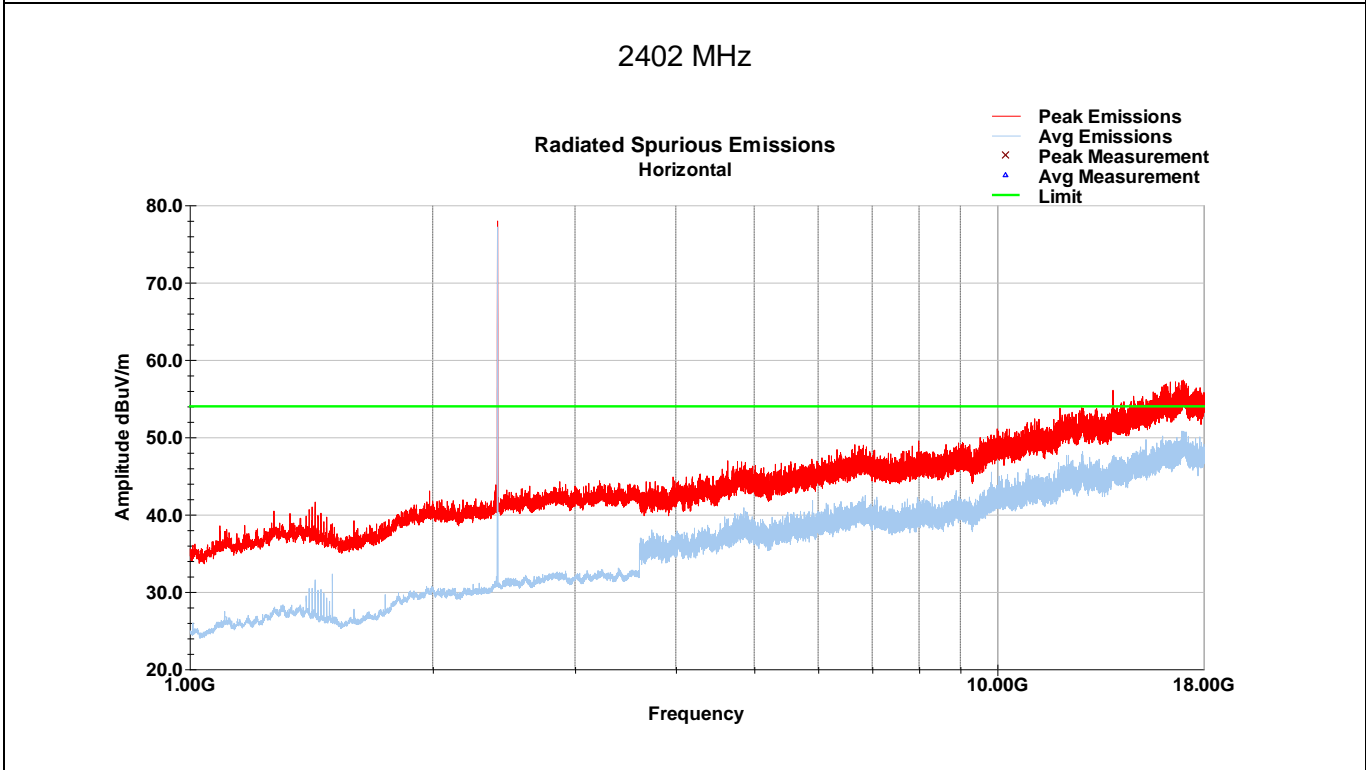
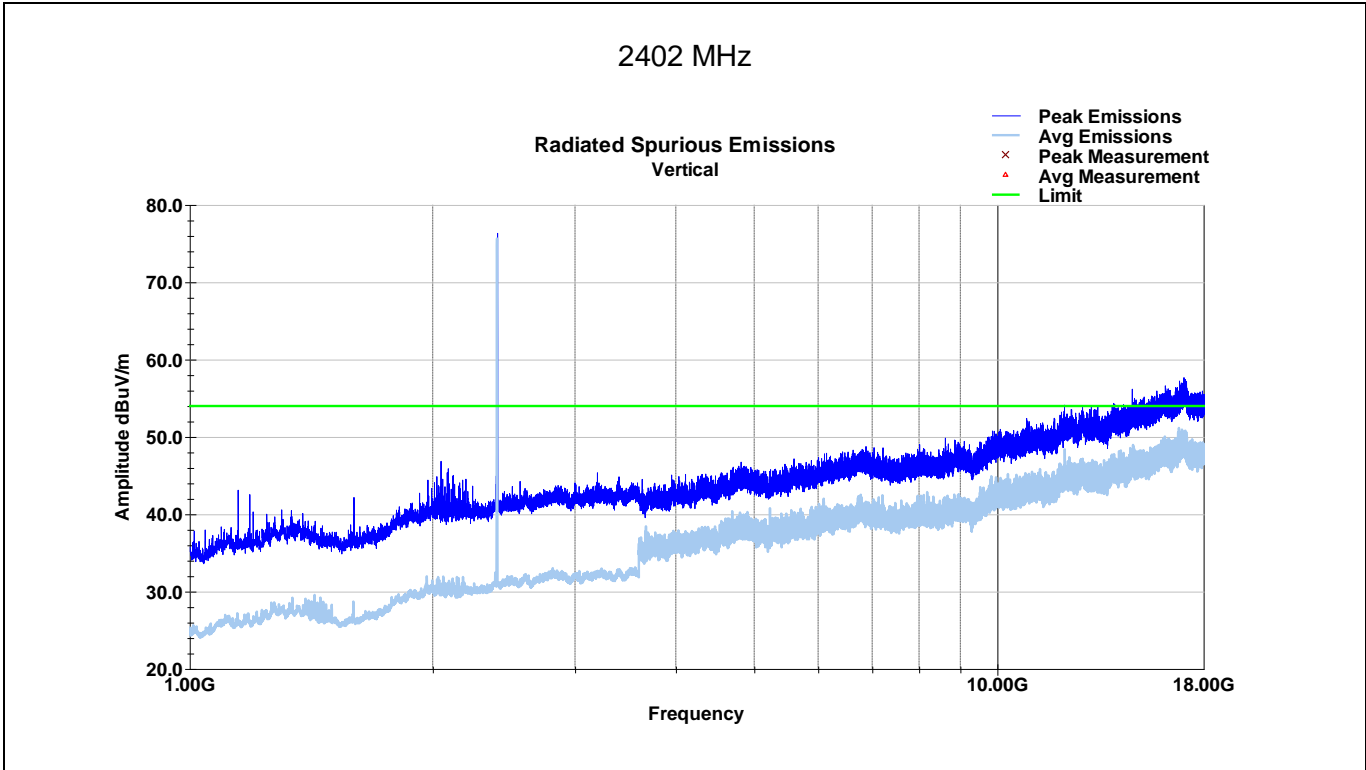

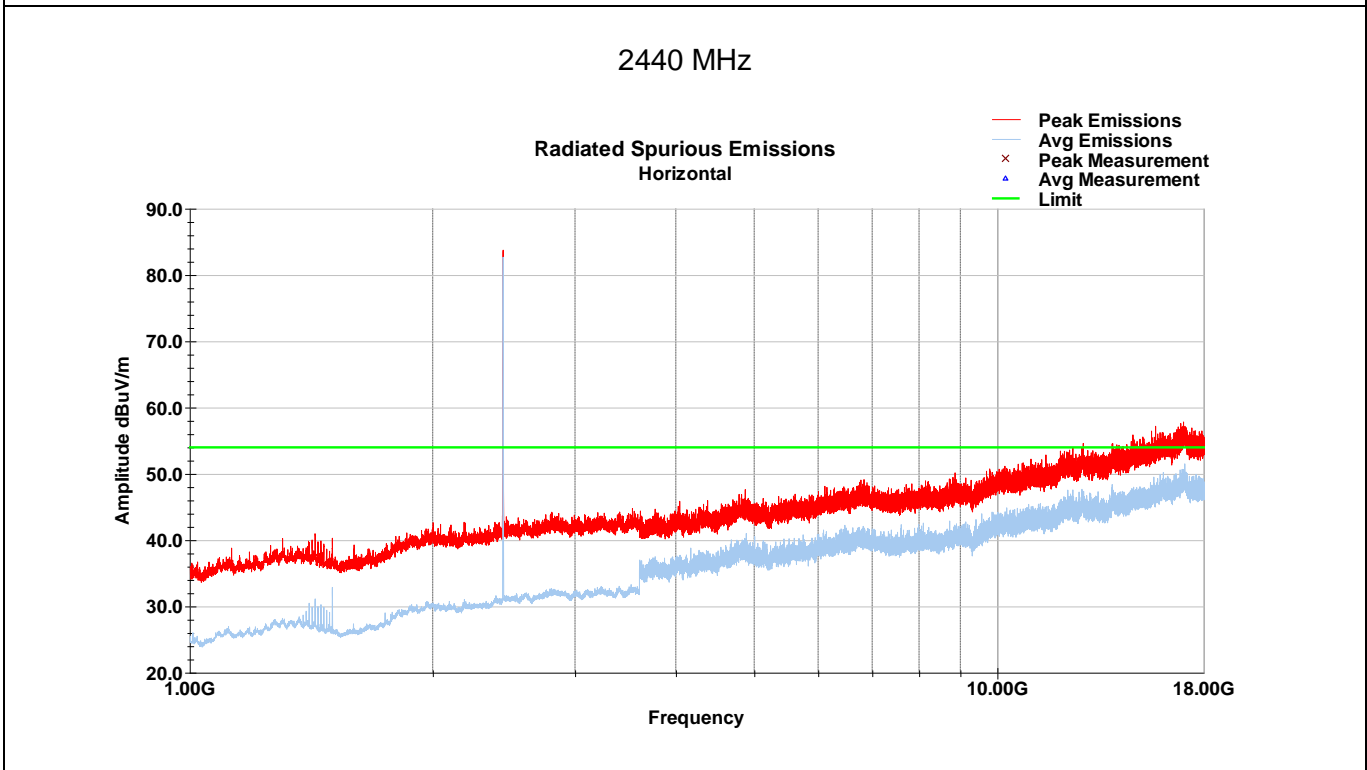
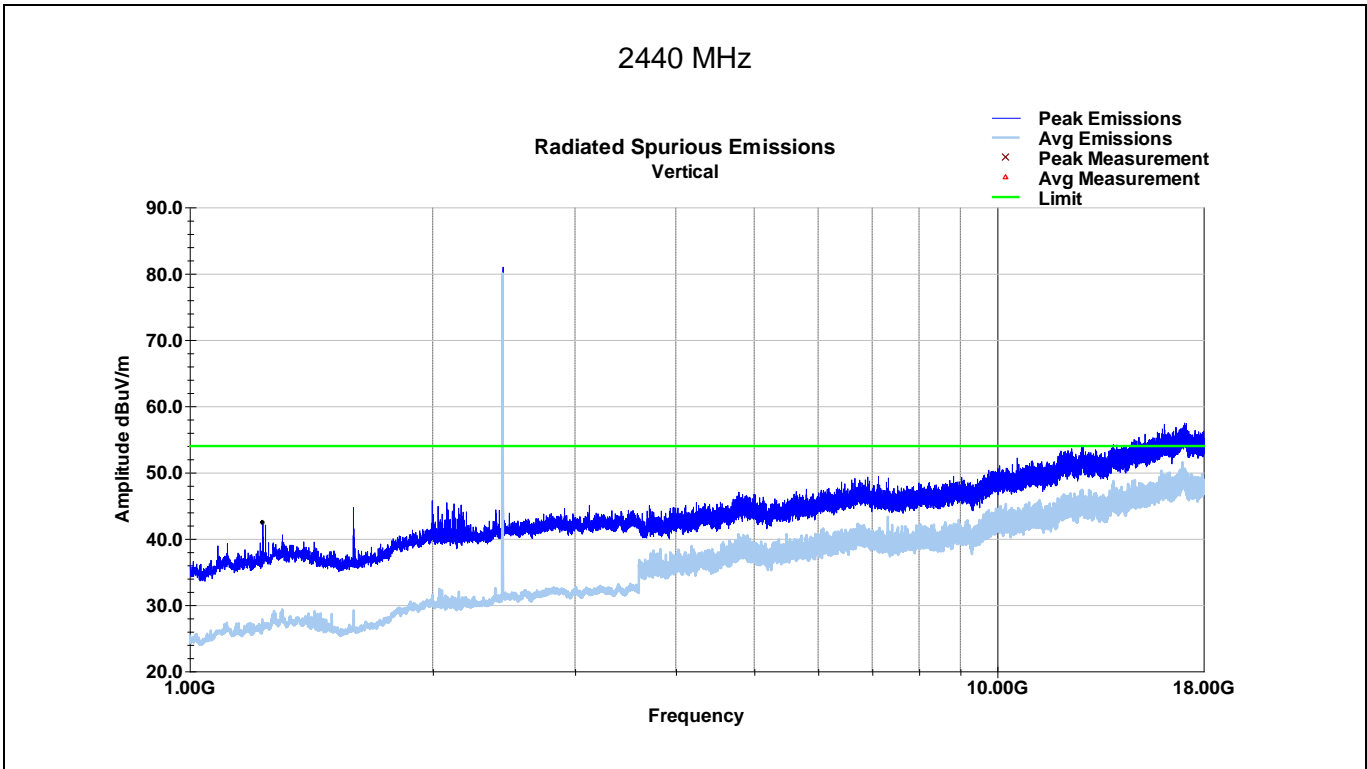

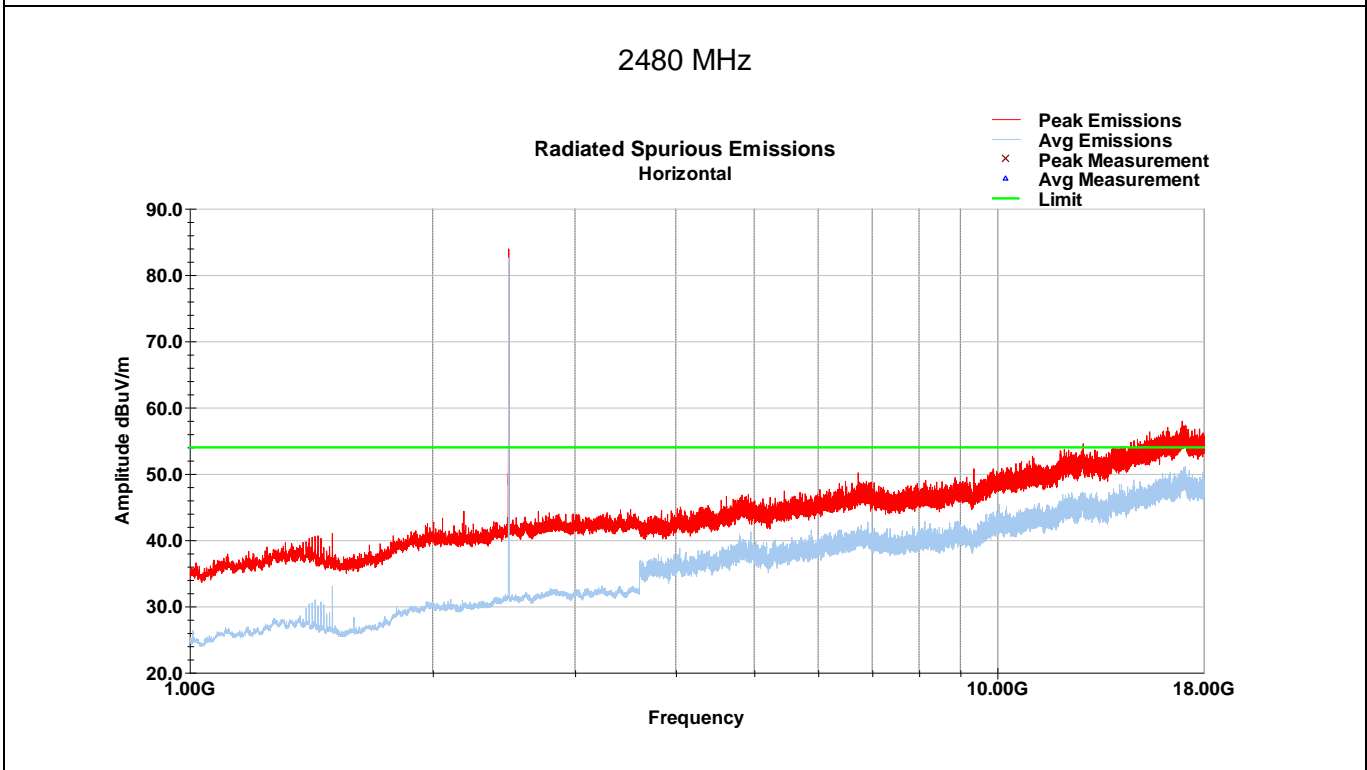
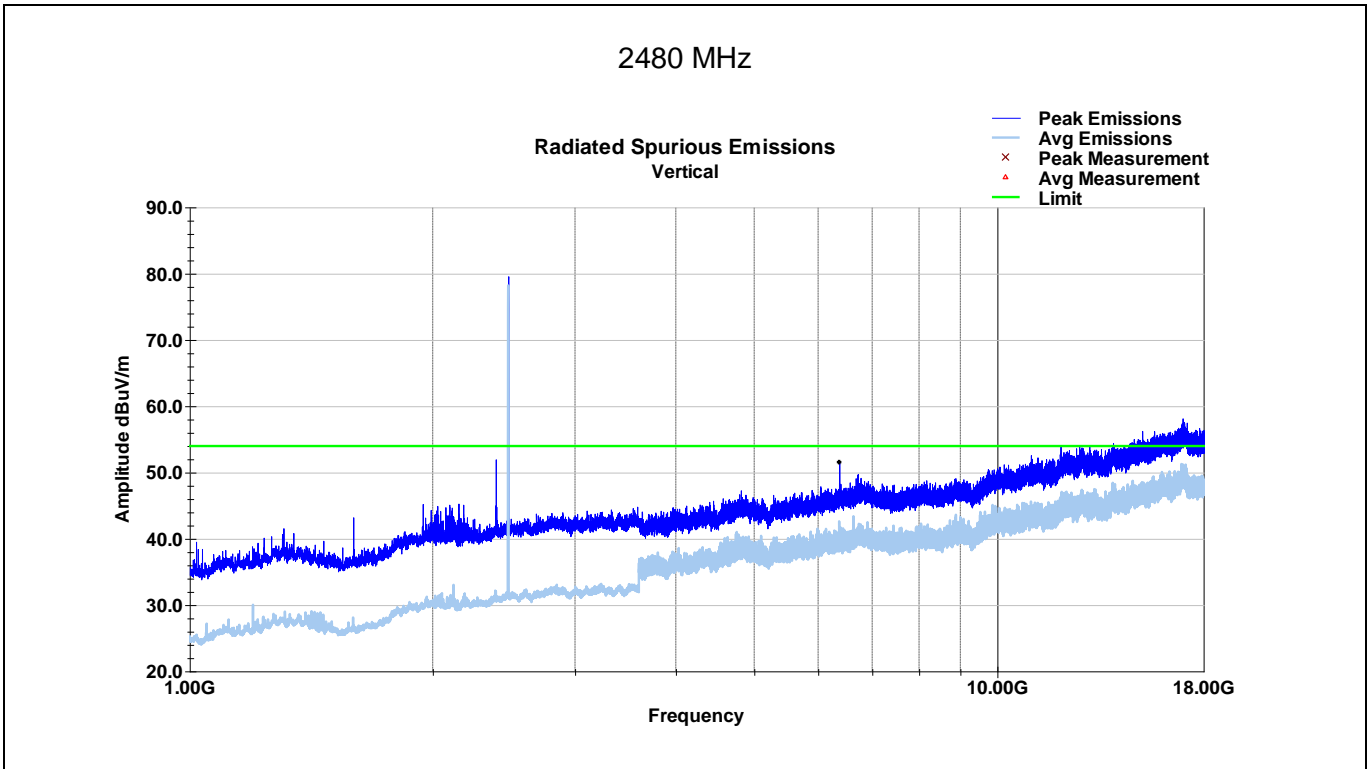

8 Band Edge Emissions in Restricted Frequency Bands

8.1 Test Result

Test Description	Test Specification		Test Result
Band Edge Emissions in Restricted Frequency Bands	15.205, 15.209	RSS-GEN S8.9, 8.10	Compliant

8.2 Test Method

Field strength measurements were performed at the restricted band edges of 2390MHz and 2483.5MHz. Measurements were made using the conducted methods defined in ANSI C63.10: 2013 clause 11.12.2. The measurements were converted to a radiated field strength equivalent using the equations defined in that section. Both peak and average measurements were performed at the antenna port.

Offset Calculations:

A reference level offset was applied to the spectrum analyzer so that conducted measurements in dBμV represent field strength measurements in dBμV/m.

$$\text{Offset} = -20\text{Log}(D) + 104.8 - 107 + \text{CL} + \text{DC} + \text{AG}$$

$$\text{Offset}_{3\text{m}} = -11.7 + \text{CL} + \text{DC} + \text{AG}$$

Where:

D = 3m	Distance
CL = 10.84 dB	Cable Loss
DC = 7.67 (17.1%)	Duty Cycle Correction Factor [10Log(1/Duty Cycle)]
AG = 2.00 dB	Antenna Gain [2 dB is the minimum allowed by the test method]

$$\text{Offset} = 10.84 \text{ dB}$$

8.3 Test Site

SGS EMC Laboratory, Suwanee, GA

Environmental Conditions

Temperature:	23.5 °C
Relative Humidity:	47.3 %
Atmospheric Pressure:	98.1 kPa

8.4 Test Equipment

Test End Date: 14-Oct-2019

Tester: ASF

Equipment	Model	Manufacturer	Asset Number	Cal Due Date
RF CABLE (TS8997)	141	HUBER & SUHNER	B095585	6-Sep-2020
ATTENUATOR, 10DB (TS8997)	10DB	ROHDE & SCHWARZ	B095591	7-Sep-2020
SIGNAL ANALYZER (TS8997)	FSV30	ROHDE & SCHWARZ	B085749	1-Nov-2019

Note: The equipment calibration period is 1 year except for the FSV which is on a 2-year cycle.

8.5 Test Data

Low Channel

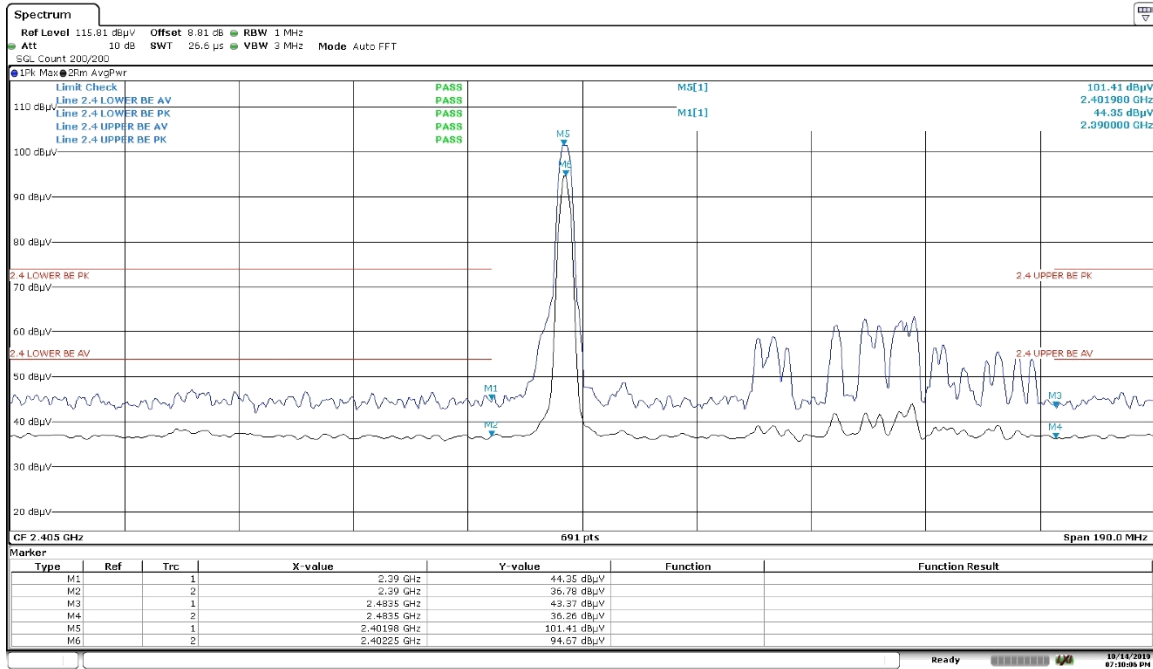

Marker 1, 2dB, MK 2, 1dB, FX, 5, 0dB
 Date: 14-OCT-2019 09:01:00

High Channel

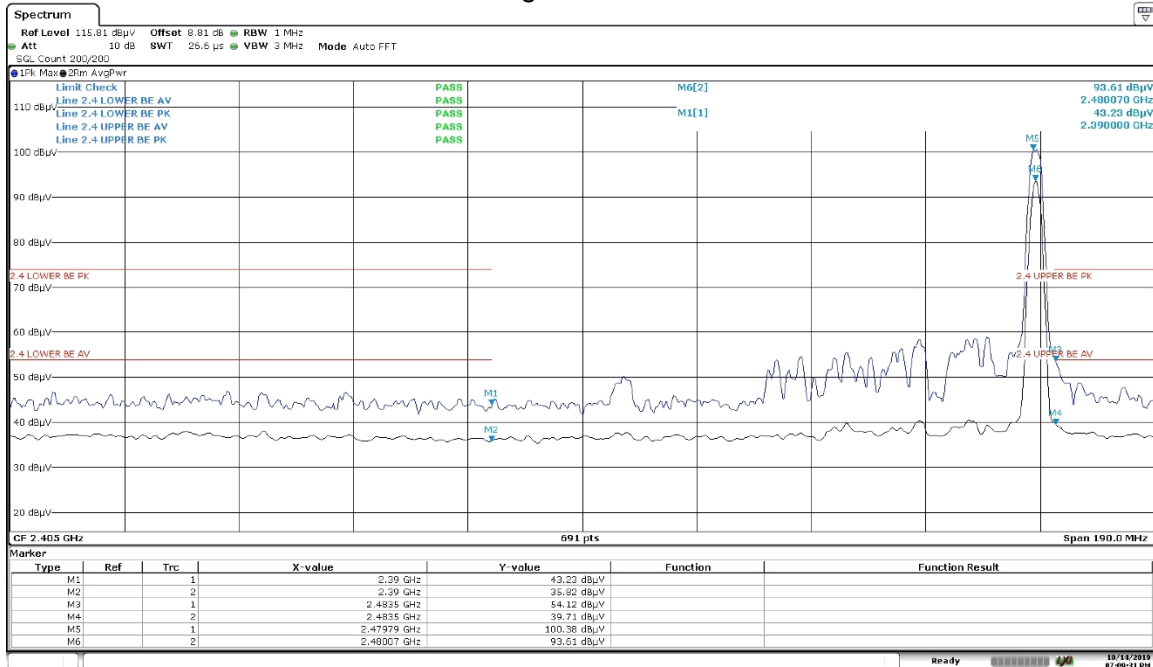

Marker 1, 2dB, MK 2, 1dB, FX, 5, 0dB
 Date: 14-OCT-2019 09:09:31

9 AC Powerline Conducted Emissions

9.1 Test Result

Test Description	Test Specification		Test Result
AC Powerline Conducted Emissions	15.207	RSS-GEN S8.8	Compliant

9.2 Test Method

With the receiver's resolution bandwidth was set to 9 kHz, exploratory scans were performed over the measuring frequency range (0.15 MHz to 30 MHz) using a max hold mode incorporating a Peak detector and Average detector and using the TILE! software. The final test data was measured using a Quasi-Peak detector and Average detector and compared against the limits indicated in the table below.

Frequency Range	Limits (dBuV)
0.15 to 0.5 MHz	Avg 56 to 46 QP 66 to 56
0.5 to 5 MHz	Avg 46 Pk 56
5 to 30 MHz	Avg 50 Pk 60

9.3 Test Site

SGS EMC Laboratory, Suwanee, GA

Environmental Conditions:

Temperature: 26.0 °C

Relative Humidity: 32.3 %

Atmospheric Pressure 97.5 kPa

9.4 Test Equipment

Test End Date: 17-Oct-2019

Tester: ASF

Equipment	Model	Manufacturer	Asset Number	Cal Due Date
LINE IMPEDANCE STABILIZATION NETWORK	NNB 51	TESEQ	B087573	3-Dec-2019
RF CABLE	UC-N-MM-78	MAURY MICROWAVE	17017	5-Sep-2020
EMI TEST RECEIVER	ESU8	ROHDE & SCHWARZ	B085759	21-Aug-2020

Software: "181112 Conducted Emissions TILE7" TILE! profile dated 12 Nov 2018

9.5 Test Data

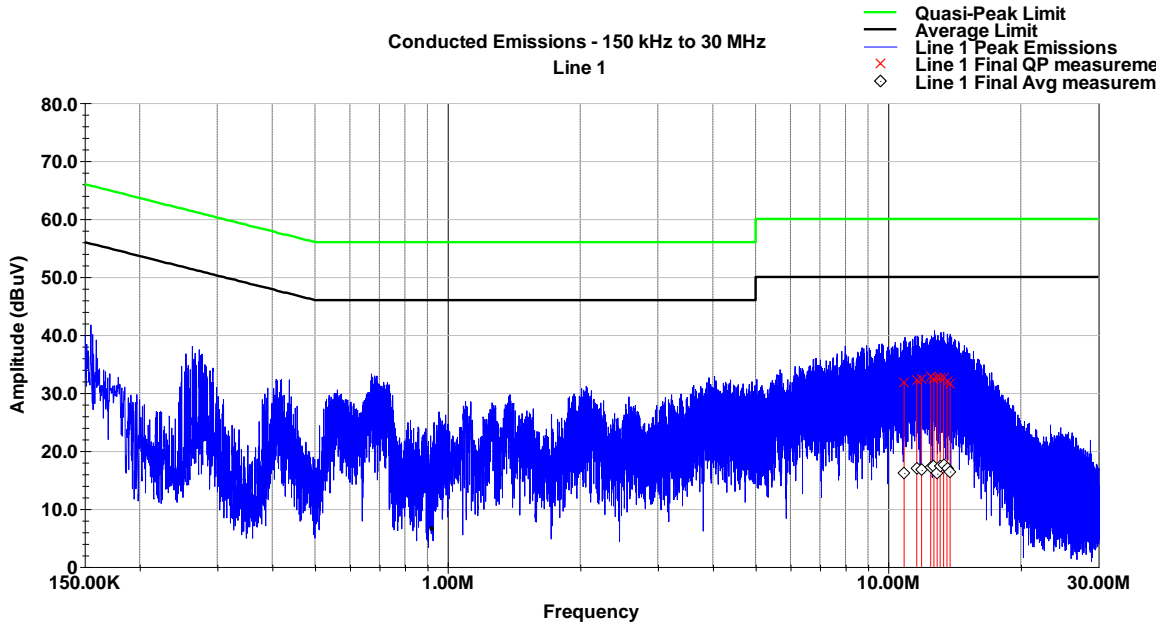

Frequency MHz	QP Value dBuV	QP Limit dBuV	QP Margin dB	Avg Value dBuV	Avg Limit dBuV	Avg Margin dB
10.867	31.9	60.0	-28.1	16.2	50.0	-33.8
11.614	32.2	60.0	-27.8	17.0	50.0	-33.0
11.905	32.5	60.0	-27.5	16.7	50.0	-33.3
12.486	32.9	60.0	-27.1	17.3	50.0	-32.7
12.700	32.4	60.0	-27.6	17.5	50.0	-32.5
12.914	32.6	60.0	-27.4	16.1	50.0	-33.9
13.121	32.6	60.0	-27.4	17.4	50.0	-32.6
13.358	32.6	60.0	-27.4	17.6	50.0	-32.4
13.597	32.1	60.0	-27.9	16.9	50.0	-33.1
13.818	31.7	60.0	-28.3	16.5	50.0	-33.5

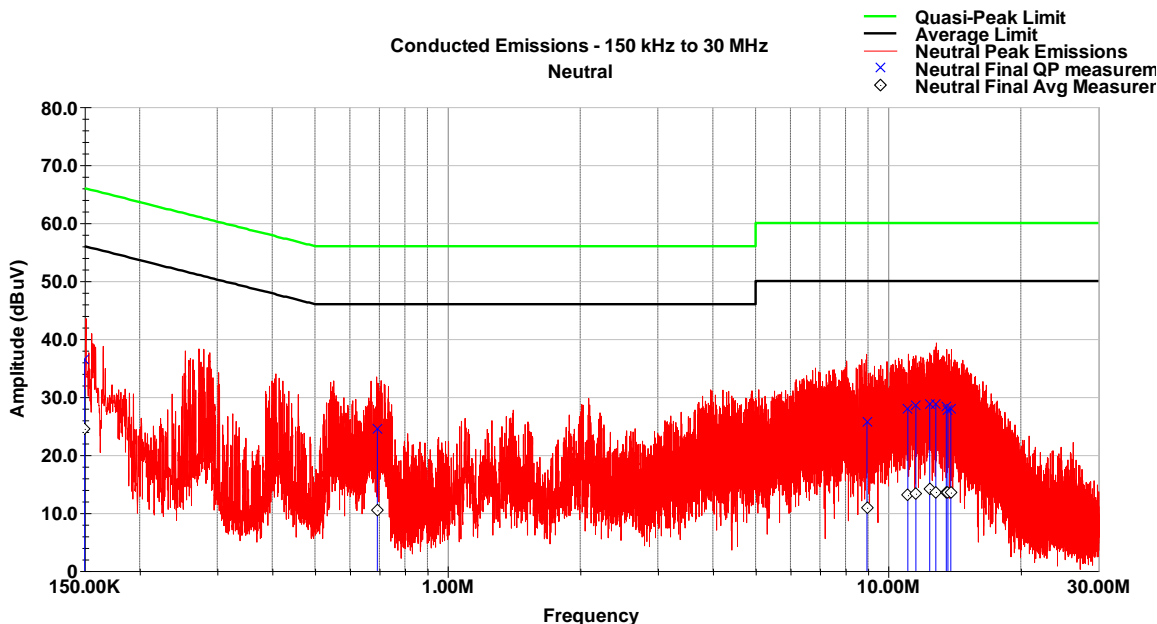

Frequency MHz	QP Value dBuV	QP Limit dBuV	QP Margin dB	Avg Value dBuV	Avg Limit dBuV	Avg Margin dB
0.150	36.5	66.0	-29.5	24.5	56.0	-31.5
0.693	24.5	56.0	-31.5	10.5	46.0	-35.5
8.951	25.7	60.0	-34.3	10.9	50.0	-39.1
11.079	28.0	60.0	-32.0	13.1	50.0	-36.9
11.558	28.5	60.0	-31.5	13.3	50.0	-36.7
12.421	28.9	60.0	-31.1	14.2	50.0	-35.8
12.828	28.7	60.0	-31.3	13.6	50.0	-36.4
13.549	28.4	60.0	-31.6	13.6	50.0	-36.4
13.659	27.8	60.0	-32.2	13.5	50.0	-36.5
13.874	28.0	60.0	-32.0	13.5	50.0	-36.5

10 Measurement Uncertainty

The measurement uncertainty figures are calculated in accordance with TR 100 028-1 [2] and correspond to an expansion factor (coverage factor) $k = 2$ (which provides confidence levels of 95.45 % in the case where the distributions characterizing the actual measurement uncertainties are normal (Gaussian)).

Parameter	Expanded Uncertainty for Normal k factor equal to 2	
	Required	Laboratory Actual
Radio Frequency	$\pm 1 \times 10^{-5}$	$\pm 9.8 \times 10^{-8}$
total RF power, conducted	± 1.5 dB	± 1.2 dB
RF power density, conducted	± 3 dB	± 0.7 dB
spurious emissions, conducted	± 3 dB	± 2.1 dB
all emissions, radiated	± 6 dB	± 4.8 dB
temperature	$\pm 1^{\circ}\text{C}$	$\pm 0.5^{\circ}\text{C}$
humidity	± 5 %	$\pm 3.5\%$
DC and low frequency voltages	± 3 %	$\pm 0.4\%$
Conducted disturbance at mains port using AMN	± 3.4 dB	± 2.5 dB

11 Revision History

Revision Level	Description of changes	Revision Date
Draft	--	4 November 2019
0	Initial release	15 Nov 2019