

FCC Test Report

Equipment : NIUX Wi-Fi module for household and professional appliances
Brand Name : Electrolux
Model No. : NIUX-UART-LIT , NIUX-USB-LIT
FCC ID : 2AIBX-NIUXL
Standard : 47 CFR FCC Part 15.247
Operating Band : 2400 MHz – 2483.5 MHz
Function : Point-to-multipoint; Point-to-point
Applicant : ELECTROLUX ITALIA S.p.A.
Corso Lino Zanussi 30 / 33080 Porcia / Italy
Manufacturer : LITE-ON Technology (Changzhou) CO.LTD
No.88, Yanghu Road, Wujin Hi-Tech Industrial Development Zone, Jiangsu Province, China
Zip Code: 213166

The product sample received on Jun. 06, 2017 and completely tested on Jul. 04, 2017. We, SPORTON, would like to declare that the tested sample has been evaluated in accordance with the procedures given in ANSI C63.10-2013 and shown compliance with the applicable technical standards.

The test results in this report apply exclusively to the tested model / sample. Without written approval of SPORTON INTERNATIONAL INC., the test report shall not be reproduced except in full.

Phoenix Chen
SPORTON INTERNATIONAL INC.





Table of Contents

1 GENERAL DESCRIPTION5

1.1 Information.....5

1.2 Testing Applied Standards7

1.3 Testing Location Information7

1.4 Measurement Uncertainty7

2 TEST CONFIGURATION OF EUT.....8

2.1 Test Condition8

2.2 Test Channel Mode8

2.3 The Worst Case Measurement Configuration.....9

2.4 Support Equipment.....10

2.5 Test Setup Diagram11

3 TRANSMITTER TEST RESULT13

3.1 AC Power-line Conducted Emissions13

3.2 DTS Bandwidth.....14

3.3 Maximum Conducted Output Power15

3.4 Power Spectral Density17

3.5 Emissions in Non-restricted Frequency Bands18

3.6 Emissions in Restricted Frequency Bands.....19

4 TEST EQUIPMENT AND CALIBRATION DATA23

APPENDIX A. TEST RESULTS OF AC POWER-LINE CONDUCTED EMISSIONS

APPENDIX B. TEST RESULTS OF DTS BANDWIDTH

APPENDIX C. TEST RESULTS OF MAXIMUM CONDUCTED OUTPUT POWER

APPENDIX D. TEST RESULTS OF POWER SPECTRAL DENSITY

APPENDIX E. TEST RESULTS OF EMISSIONS IN NON-RESTRICTED FREQUENCY BANDS

APPENDIX F. TEST RESULTS OF EMISSIONS IN RESTRICTED FREQUENCY BANDS

APPENDIX G. TEST PHOTOS

PHOTOGRAPHS OF EUT v01



Summary of Test Result

Conformance Test Specifications				
Report Clause	Ref. Std. Clause	Description	Limit	Result
1.1.2	15.203	Antenna Requirement	FCC 15.203	Complied
3.1	15.207	AC Power-line Conducted Emissions	FCC 15.207	Complied
3.2	15.247(a)	DTS Bandwidth	≥500kHz	Complied
3.3	15.247(b)	Maximum Conducted Output Power	Power [dBm]:30	Complied
3.4	15.247(e)	Power Spectral Density	PSD [dBm/3kHz]:8	Complied
3.5	15.247(d)	Emissions in Non-restricted Frequency Bands	Non-Restricted Bands: > 30 dBc	Complied
3.6	15.247(d)	Emissions in Restricted Frequency Bands	Restricted Bands: FCC 15.209	Complied



1 General Description

1.1 Information

1.1.1 RF General Information

Frequency Range (MHz)	IEEE Std. 802.11	Ch. Frequency (MHz)	Channel Number
2400-2483.5	b, g, n (HT20)	2412-2462	1-11 [11]
2400-2483.5	n (HT40)	2422-2452	3-9 [7]

Band	Mode	BWch (MHz)	Nant
2.4-2.4835GHz	802.11b	20	2TX
2.4-2.4835GHz	802.11g	20	2TX
2.4-2.4835GHz	802.11n HT20	20	2TX
2.4-2.4835GHz	802.11n HT40	40	2TX

Note:

- ♦ 11b mode uses a combination of DSSS-DBPSK, DQPSK, CCK modulation.
- ♦ 11g, HT20 and HT40 use a combination of OFDM-BPSK, QPSK, 16QAM, 64QAM modulation.
- ♦ BWch is the nominal channel bandwidth.

1.1.2 Antenna Information

Ant.	Port	Brand	Model Name	Antenna Type	Connector	Gain (dBi)
1	1	INPAQ	-	PIFA	Murata	3.08
2	2	INPAQ	-	PIFA	Murata	3.31

1.1.3 EUT Information

Operational Condition	
EUT Power Type	From Host System
Beamforming Function	<input type="checkbox"/> With beamforming <input checked="" type="checkbox"/> Without beamforming
Type of EUT	
<input checked="" type="checkbox"/>	Stand-alone
<input type="checkbox"/>	Combined (EUT where the radio part is fully integrated within another device)
	Combined Equipment - Brand Name / Model No.: ...
<input type="checkbox"/>	Plug-in radio (EUT intended for a variety of host systems)
	Host System - Brand Name / Model No.: ...
<input type="checkbox"/>	Other:



1.1.4 Mode Test Duty Cycle

Mode	DC	DCF(dB)	T(s)	VBW(Hz) ≥ 1/T
802.11b	0.996	0.017	n/a (DC>=0.98)	n/a (DC>=0.98)
802.11g	0.978	0.097	2.026m	1k
802.11n HT20	0.973	0.119	1.889m	1k
802.11n HT40	1	0	n/a (DC>=0.98)	n/a (DC>=0.98)

1.1.5 Table for Multiple Listing

The detail in the following table are all refer to the identical product.

Model	Description	
	connector	POWER IC
NIUX-UART-LIT	X	X
NIUX-USB-LIT	O	O

Note. For more detailed features description, please refer to the specifications or user's manual.

1.2 Testing Applied Standards

According to the specifications of the manufacturer, the EUT must comply with the requirements of the following standards:

- ◆ 47 CFR FCC Part 15
- ◆ ANSI C63.10-2013
- ◆ KDB 558074 D01 v04
- ◆ KDB 662911 D01 v02r01

1.3 Testing Location Information

Testing Location				
<input checked="" type="checkbox"/>	HWA YA	ADD : No. 52, Huaya 1st Rd., Guishan Dist., Taoyuan City, Taiwan (R.O.C.)		
		TEL : 886-3-327-3456	FAX : 886-3-327-0973	
Test site Designation No. 553509 with FCC.				
<input type="checkbox"/>	JHUBEI	ADD : No.8, Ln. 724, Bo'ai St., Zhubei City, Hsinchu County, Taiwan (R.O.C.)		
		TEL : 886-3-656-9065	FAX : 886-3-656-9085	
Test site Designation No. TW0006 with FCC.				
Test Condition	Test Site No.	Test Engineer	Test Environment	Test Date
AC Conduction	CO04-HY	Teddy	22°C / 55%	04/Jul/2017
RF Conducted	TH06-HY	Gary	21°C / 61%	30/Jun/2017
Radiated	03CH09-HY	Terry	20.3°C / 58%	28/Jun/2017

1.4 Measurement Uncertainty

ISO/IEC 17025 requires that an estimate of the measurement uncertainties associated with the emissions test results be included in the report. The measurement uncertainties given below are based on a 95% confidence level (based on a coverage factor (k=2))

Test Items	Uncertainty	Remark
Conducted Emission (150kHz ~ 30MHz)	3.6 dB	Confidence levels of 95%
Radiated Emission (30MHz ~ 1,000MHz)	2.1 dB	Confidence levels of 95%
Radiated Emission (1GHz ~ 18GHz)	2.6 dB	Confidence levels of 95%
Radiated Emission (18GHz ~ 40GHz)	2.9 dB	Confidence levels of 95%
Conducted Emission	1.3 dB	Confidence levels of 95%



2 Test Configuration of EUT

2.1 Test Condition

Condition Item	Abbreviation/Remark	Remark
RF Conducted	Abbreviation	Remark
TnomVnom	Tnom	20°C
-	Vnom	120V

2.2 Test Channel Mode



Test Software	ART2
---------------	------

Mode	Power Setting
802.11b_(1Mbps)_2TX	-
2412MHz	15.5
2437MHz	16
2462MHz	15
802.11g_(6Mbps)_2TX	-
2412MHz	16
2437MHz	23
2462MHz	16
802.11n HT20_Nss1,(MCS0)_2TX	-
2412MHz	14.5
2437MHz	22.5
2462MHz	16.5
802.11n HT40_Nss1,(MCS0)_2TX	-
2422MHz	12.5
2437MHz	19
2452MHz	16

2.3 The Worst Case Measurement Configuration

The Worst Case Mode for Following Conformance Tests	
Tests Item	AC power-line conducted emissions
Condition	AC power-line conducted measurement for line and neutral
Operating Mode	Normal Link
1	USB mode

The Worst Case Mode for Following Conformance Tests	
Tests Item	DTS Bandwidth Maximum Conducted Output Power Power Spectral Density Emissions in Non-restricted Frequency Bands
Test Condition	Conducted measurement at transmit chains

The Worst Case Mode for Following Conformance Tests		
Tests Item	Emissions in Restricted Frequency Bands	
Test Condition	Radiated measurement If EUT consist of multiple antenna assembly (multiple antenna are used in EUT regardless of spatial multiplexing MIMO configuration), the radiated test should be performed with highest antenna gain of each antenna type.	
Operating Mode < 1GHz	Normal Link	
1	USB mode	
Operating Mode > 1GHz	CTX	
Orthogonal Planes of EUT	Y Plane	Z Plane
		
Worst Planes of EUT		V



2.4 Support Equipment

Support Equipment – AC Conduction				
No.	Equipment	Brand Name	Model Name	FCC ID
A	Notebook	DELL	Vostro 3350	DoC
B	Mouse	Microsoft	1113	DoC
C	Adapter	-	GM-1018-S05	DoC
D	fixture	-	-	-
Z	Wireless Access Point	ASUS	RT-AC66U	N/MSQ-RTAC66U

Support Equipment – RF Conducted				
No.	Equipment	Brand Name	Model Name	FCC ID
1	Notebook	DELL	E5410	DoC
2	Adapter for NB	DELL	HA65NM130	DoC
3	AC Source	GW	APS-9102	-

Support Equipment – Radiated Emission				
No.	Equipment	Brand Name	Model Name	FCC ID
1	Notebook	DELL	E5530	DoC
2	Adapter for NB	DELL	LA65NS2-01	DoC
3	UBS cable	-	-	DoC
4	Mouse(USB)	Microsoft	R32164	DoC
5	iPod	APPLE	7J6416BZVQ5	DoC

Note: Support equipment No.3 was provided by customer.

2.5 Test Setup Diagram

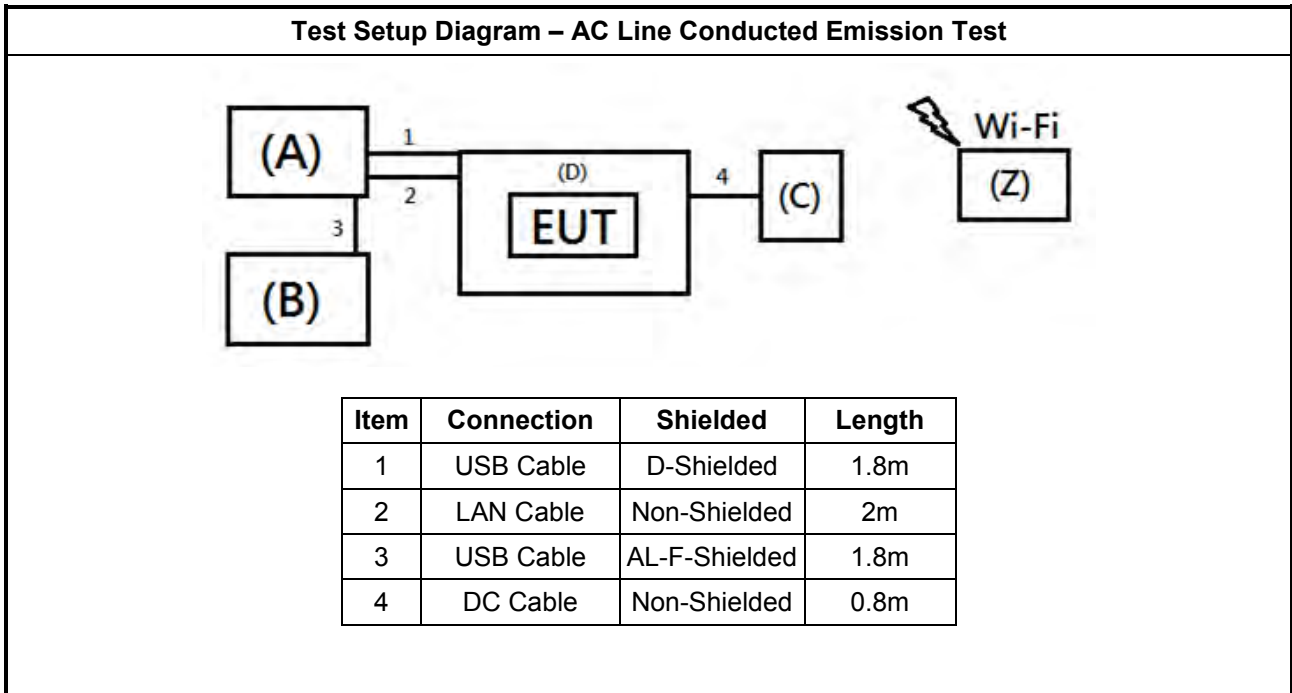

Test Setup Diagram - Radiated Test < 1GHz

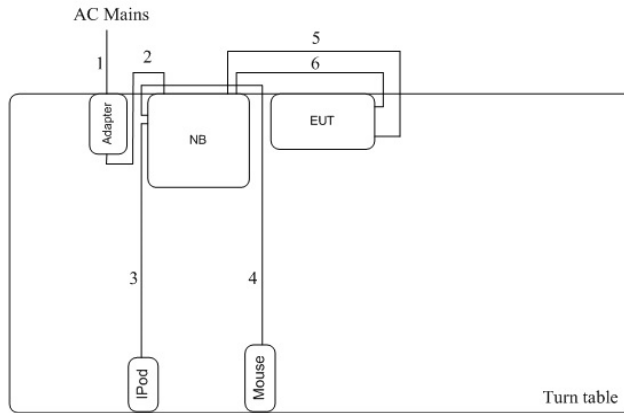

Item	Connection	Shielded	Length
1	AC Power line	No	1.8m
2	DC Power line	No	1.8m
3	USB cable	D	1.5m
4	USB cable	D	1.5m
5	USB cable	D	1.7m
6	Lan Cable	No	0.7m

Test Setup Diagram - Radiated Test > 1GHz

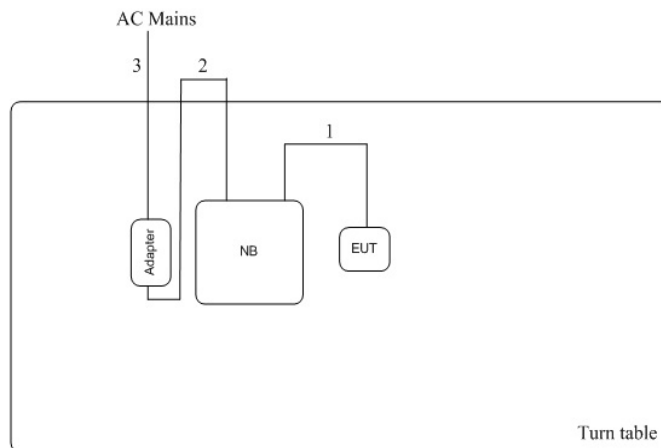

Item	Connection	Shielded	Length
1	USB cable	D	1.7m
2	DC Power line	No	1.8m
3	AC Power line	No	1.8m

3 Transmitter Test Result

3.1 AC Power-line Conducted Emissions

3.1.1 AC Power-line Conducted Emissions Limit

AC Power-line Conducted Emissions Limit		
Frequency Emission (MHz)	Quasi-Peak	Average
0.15-0.5	66 - 56 *	56 - 46 *
0.5-5	56	46
5-30	60	50

Note 1: * Decreases with the logarithm of the frequency.

3.1.2 Measuring Instruments

Refer a test equipment and calibration data table in this test report.

3.1.3 Test Procedures

Test Method
<input checked="" type="checkbox"/> Refer as ANSI C63.10-2013, clause 6.2 for AC power-line conducted emissions.

3.1.4 Test Setup

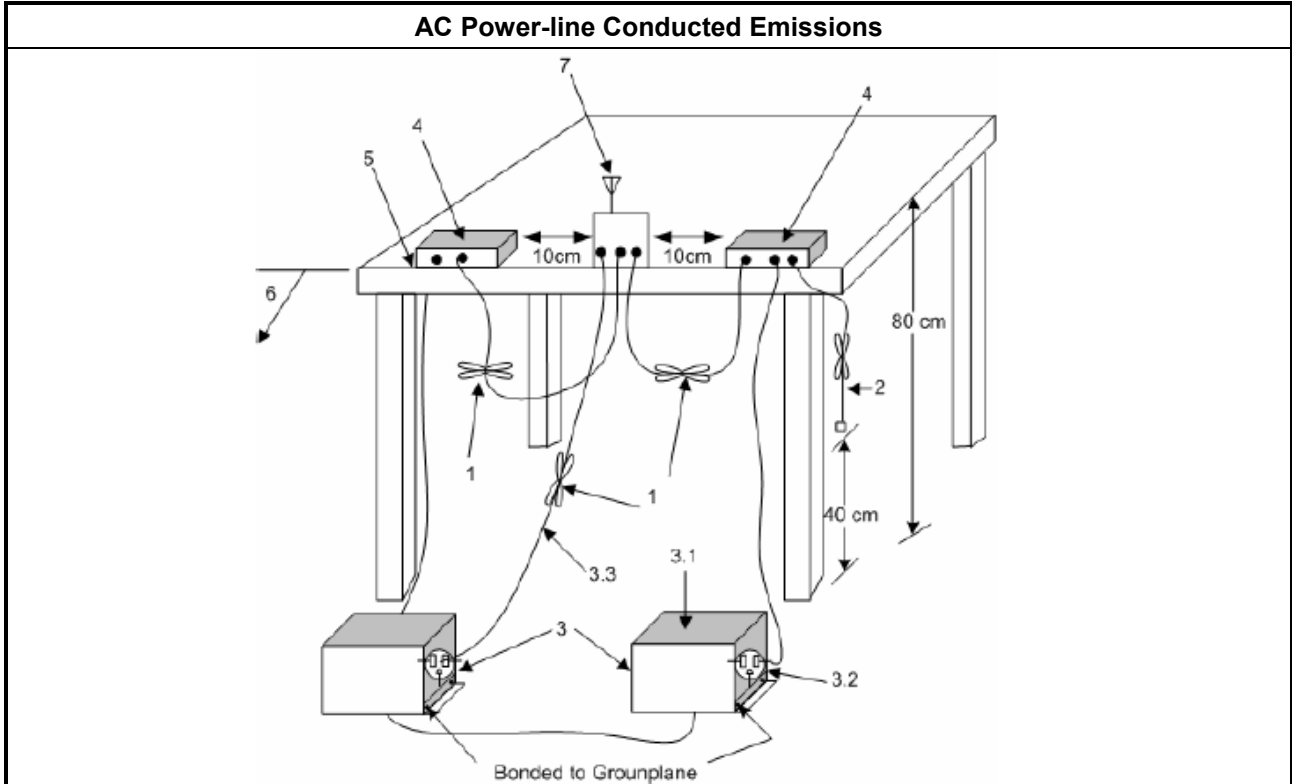

3.1.5 Test Result of AC Power-line Conducted Emissions

Refer as Appendix A

3.2 DTS Bandwidth

3.2.1 6dB Bandwidth Limit

6dB Bandwidth Limit
Systems using digital modulation techniques:
<ul style="list-style-type: none"> ▪ 6 dB bandwidth \geq 500 kHz.

3.2.2 Measuring Instruments

Refer a test equipment and calibration data table in this test report.

3.2.3 Test Procedures

Test Method	
<ul style="list-style-type: none"> ▪ For the emission bandwidth shall be measured using one of the options below: 	
<input checked="" type="checkbox"/>	Refer as KDB 558074, clause 8.1 Option 1 for 6 dB bandwidth measurement.
<input type="checkbox"/>	Refer as KDB 558074, clause 8.2 Option 2 for 6 dB bandwidth measurement.
<input type="checkbox"/>	Refer as ANSI C63.10, clause 6.9.3 for occupied bandwidth testing.

3.2.4 Test Setup

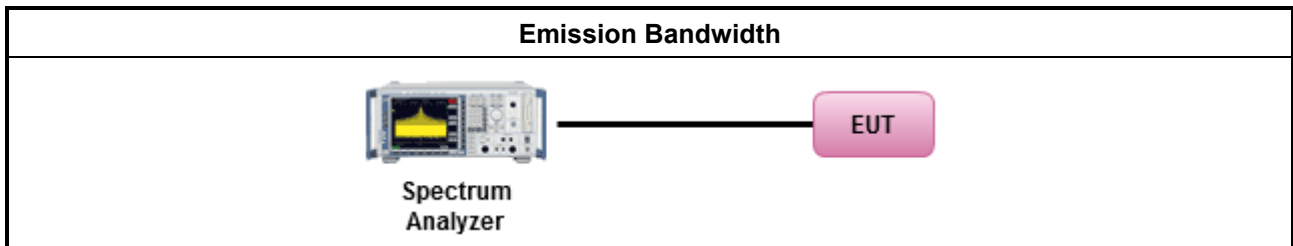

3.2.5 Test Result of Emission Bandwidth

Refer as Appendix B

3.3 Maximum Conducted Output Power

3.3.1 Maximum Conducted Output Power Limit

Maximum Conducted Output Power Limit	
	<ul style="list-style-type: none"> ▪ If $G_{TX} \leq 6$ dBi, then $P_{Out} \leq 30$ dBm (1 W)
	<ul style="list-style-type: none"> ▪ Point-to-multipoint systems (P2M): If $G_{TX} > 6$ dBi, then $P_{Out} = 30 - (G_{TX} - 6)$ dBm
	<ul style="list-style-type: none"> ▪ Point-to-point systems (P2P): If $G_{TX} > 6$ dBi, then $P_{Out} = 30 - (G_{TX} - 6)/3$ dBm
	<ul style="list-style-type: none"> ▪ Smart antenna system (SAS):
	<ul style="list-style-type: none"> - Single beam: If $G_{TX} > 6$ dBi, then $P_{Out} = 30 - (G_{TX} - 6)/3$ dBm
	<ul style="list-style-type: none"> - Overlap beam: If $G_{TX} > 6$ dBi, then $P_{Out} = 30 - (G_{TX} - 6)/3$ dBm
	<ul style="list-style-type: none"> - Aggregate power on all beams: If $G_{TX} > 6$ dBi, then $P_{Out} = 30 - (G_{TX} - 6)/3 + 8$ dBm
e.i.r.p. Power Limit:	
	<ul style="list-style-type: none"> ▪ 2400-2483.5 MHz Band
	<ul style="list-style-type: none"> ▪ Point-to-multipoint systems (P2M): $P_{eirp} \leq 36$ dBm (4 W)
	<ul style="list-style-type: none"> ▪ Point-to-point systems (P2P): $P_{eirp} \leq \text{MAX}(36, [P_{Out} + G_{TX}])$ dBm
	<ul style="list-style-type: none"> ▪ Smart antenna system (SAS)
	<ul style="list-style-type: none"> - Single beam: $P_{eirp} \leq \text{MAX}(36, P_{Out} + G_{TX})$ dBm
	<ul style="list-style-type: none"> - Overlap beam: $P_{eirp} \leq \text{MAX}(36, P_{Out} + G_{TX})$ dBm
	<ul style="list-style-type: none"> - Aggregate power on all beams: $P_{eirp} \leq \text{MAX}(36, [P_{Out} + G_{TX} + 8])$ dBm
<p>P_{Out} = maximum peak conducted output power or maximum conducted output power in dBm, G_{TX} = the maximum transmitting antenna directional gain in dBi.</p>	

3.3.2 Measuring Instruments

Refer a test equipment and calibration data table in this test report.

3.3.3 Test Procedures

Test Method	
<ul style="list-style-type: none"> ▪ Maximum Peak Conducted Output Power 	
	<input type="checkbox"/> Refer as KDB 558074, clause 9.1.1 Option 1 (RBW ≥ EBW method).
	<input type="checkbox"/> Refer as KDB 558074, clause 9.1.2 Option 2 (integrated band power method)
	<input type="checkbox"/> Refer as KDB 558074, clause 9.1.3 Option 3 (peak power meter for VBW ≥ DTS BW)
<ul style="list-style-type: none"> ▪ Maximum Average Conducted Output Power 	
	Duty cycle ≥ 98%
	<input type="checkbox"/> Refer as KDB 558074, clause 9.2.2.4 Method AVGSA-2 (spectral trace averaging).
	Duty cycle < 98%
	<input type="checkbox"/> Refer as KDB 558074, clause 9.2.2.5 Method AVGSA-2 Alt. (slow sweep speed)
	RF power meter and average over on/off periods with duty factor or gated trigger
	<input checked="" type="checkbox"/> Refer as KDB 558074, clause 9.2.3.1 Method AVGPM (using an RF average power meter).
<ul style="list-style-type: none"> ▪ For conducted measurement. 	
	<ul style="list-style-type: none"> ▪ If the EUT supports multiple transmit chains using options given below: Refer as KDB 662911, In-band power measurements. Using the measure-and-sum approach, measured all transmit ports individually. Sum the power (in linear power units e.g., mW) of all ports for each individual sample and save them.
	<ul style="list-style-type: none"> ▪ If multiple transmit chains, EIRP calculation could be following as methods: $P_{total} = P_1 + P_2 + \dots + P_n$ (calculated in linear unit [mW] and transfer to log unit [dBm]) $EIRP_{total} = P_{total} + DG$

3.3.4 Test Setup

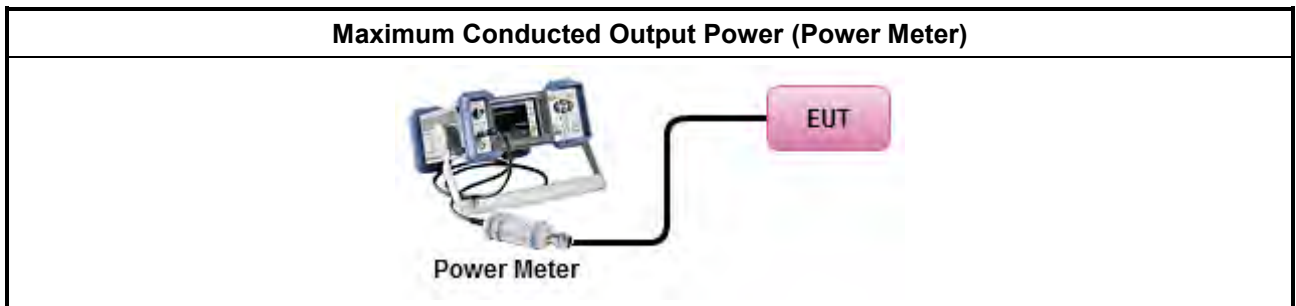

3.3.5 Test Result of Maximum Conducted Output Power

Refer as Appendix C

3.4 Power Spectral Density

3.4.1 Power Spectral Density Limit

Power Spectral Density Limit
<ul style="list-style-type: none"> Power Spectral Density (PSD) \leq 8 dBm/3kHz

3.4.2 Measuring Instruments

Refer a test equipment and calibration data table in this test report.

3.4.3 Test Procedures

Test Method	
<ul style="list-style-type: none"> Peak power spectral density procedures that the same method as used to determine the conducted output power. If maximum peak conducted output power was measured to demonstrate compliance to the output power limit, then the peak PSD procedure below (Method PKPSD) shall be used. If maximum conducted output power was measured to demonstrate compliance to the output power limit, then one of the average PSD procedures shall be used, as applicable based on the following criteria (the peak PSD procedure is also an acceptable option). 	
<input checked="" type="checkbox"/>	Refer as KDB 558074, clause 10.2 Method PKPSD (RBW=3-100kHz; Detector=peak).
<ul style="list-style-type: none"> For conducted measurement. 	
<ul style="list-style-type: none"> If The EUT supports multiple transmit chains using options given below: 	
<input checked="" type="checkbox"/>	Measure and sum the spectra across the outputs. Refer as KDB 662911, In-band power spectral density (PSD). Sample all transmit ports simultaneously using a spectrum analyzer for each transmit port. Where the trace bin-by-bin of each transmit port summing can be performed. (i.e., in the first spectral bin of output 1 is summed with that in the first spectral bin of output 2 and that from the first spectral bin of output 3, and so on up to the NTX output to obtain the value for the first frequency bin of the summed spectrum.). Add up the amplitude (power) values for the different transmit chains and use this as the new data trace.

3.4.4 Test Setup

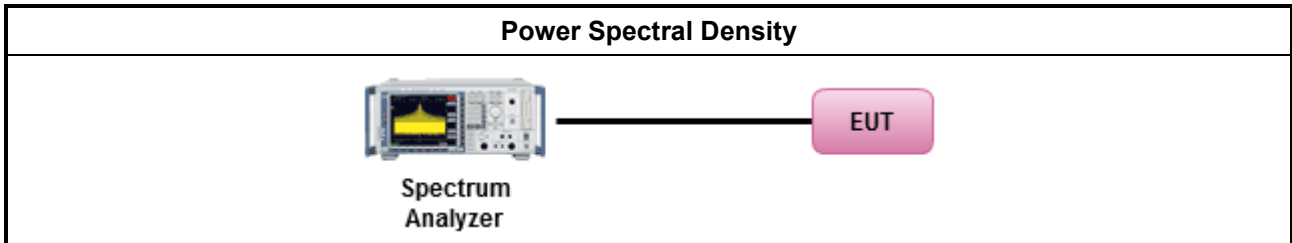

3.4.5 Test Result of Power Spectral Density

Refer as Appendix D

3.5 Emissions in Non-restricted Frequency Bands

3.5.1 Emissions in Non-restricted Frequency Bands Limit

Un-restricted Band Emissions Limit	
RF output power procedure	Limit (dB)
Peak output power procedure	20
Average output power procedure	30

Note 1: If the peak output power procedure is used to measure the fundamental emission power to demonstrate compliance to requirements, then the peak conducted output power measured within any 100 kHz outside the authorized frequency band shall be attenuated by at least 20 dB relative to the maximum measured in-band peak PSD level.

Note 2: If the average output power procedure is used to measure the fundamental emission power to demonstrate compliance to requirements, then the power in any 100 kHz outside of the authorized frequency band shall be attenuated by at least 30 dB relative to the maximum measured in-band average PSD level.

3.5.2 Measuring Instruments

Refer a test equipment and calibration data table in this test report.

3.5.3 Test Procedures

Test Method
<ul style="list-style-type: none"> Refer as KDB 558074, clause 11 for unwanted emissions into non-restricted bands.

3.5.4 Test Setup

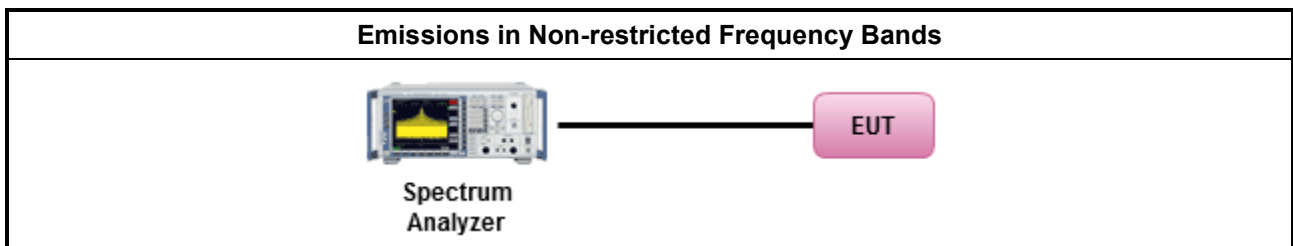

3.5.5 Test Result of Emissions in Non-restricted Frequency Bands

Refer as Appendix E



3.6 Emissions in Restricted Frequency Bands

3.6.1 Emissions in Restricted Frequency Bands Limit

Restricted Band Emissions Limit			
Frequency Range (MHz)	Field Strength (uV/m)	Field Strength (dBuV/m)	Measure Distance (m)
0.009~0.490	2400/F(kHz)	48.5 - 13.8	300
0.490~1.705	24000/F(kHz)	33.8 - 23	30
1.705~30.0	30	29	30
30~88	100	40	3
88~216	150	43.5	3
216~960	200	46	3
Above 960	500	54	3

Note 1: Test distance for frequencies at or above 30 MHz, measurements may be performed at a distance other than the limit distance provided they are not performed in the near field and the emissions to be measured can be detected by the measurement equipment. When performing measurements at a distance other than that specified, the results shall be extrapolated to the specified distance using an extrapolation factor of 20 dB/decade (inverse of linear distance for field-strength measurements, inverse of linear distance-squared for power-density measurements).

Note 2: Test distance for frequencies at below 30 MHz, measurements may be performed at a distance closer than the EUT limit distance; however, an attempt should be made to avoid making measurements in the near field. When performing measurements below 30 MHz at a closer distance than the limit distance, the results shall be extrapolated to the specified distance by either making measurements at a minimum of two or more distances on at least one radial to determine the proper extrapolation factor or by using the square of an inverse linear distance extrapolation factor (40 dB/decade). The test report shall specify the extrapolation method used to determine compliance of the EUT.

3.6.2 Measuring Instruments

Refer a test equipment and calibration data table in this test report.



3.6.3 Test Procedures

Test Method	
<ul style="list-style-type: none"> ▪ The average emission levels shall be measured in [duty cycle \geq 98 or duty factor]. 	
<ul style="list-style-type: none"> ▪ Refer as ANSI C63.10, clause 6.10.3 band-edge testing shall be performed at the lowest frequency channel and highest frequency channel within the allowed operating band. 	
<ul style="list-style-type: none"> ▪ For the transmitter unwanted emissions shall be measured using following options below: 	
<ul style="list-style-type: none"> ▪ Refer as KDB 558074, clause 12 for unwanted emissions into restricted bands. 	
	<ul style="list-style-type: none"> <input checked="" type="checkbox"/> Refer as KDB 558074, clause 12.2.5.3 (ANSI C63.10, clause 4.1.4.2.3), Reduced VBW\geq1/T.
	<ul style="list-style-type: none"> <input checked="" type="checkbox"/> Refer as KDB 558074, clause 12.2.4 measurement procedure peak limit.
<ul style="list-style-type: none"> ▪ For the transmitter band-edge emissions shall be measured using following options below: 	
	<ul style="list-style-type: none"> ▪ Refer as KDB 558074 clause 13.1, When the performing peak or average radiated measurements, emissions within 2 MHz of the authorized band edge may be measured using the marker-delta method described below.
	<ul style="list-style-type: none"> ▪ Refer as KDB 558074, clause 13.2 (ANSI C63.10, clause 6.10.6) for marker-delta method for band-edge measurements.
	<ul style="list-style-type: none"> ▪ Refer as KDB 558074, clause 13.3 for narrower resolution bandwidth (100kHz) using the band power and summing the spectral levels (i.e., 1 MHz).
<ul style="list-style-type: none"> ▪ For conducted and cabinet radiation measurement, refer as KDB 558074, clause 12.2.2. 	
	<ul style="list-style-type: none"> ▪ For conducted unwanted emissions into restricted bands (absolute emission limits). Devices with multiple transmit chains using options given below: (1) Measure and sum the spectra across the outputs or (2) Measure and add 10 log(N) dB
	<ul style="list-style-type: none"> ▪ For KDB 662911 The methodology described here may overestimate array gain, thereby resulting in apparent failures to satisfy the out-of-band limits even if the device is actually compliant. In such cases, compliance may be demonstrated by performing radiated tests around the frequencies at which the apparent failures occurred.

3.6.4 Test Setup

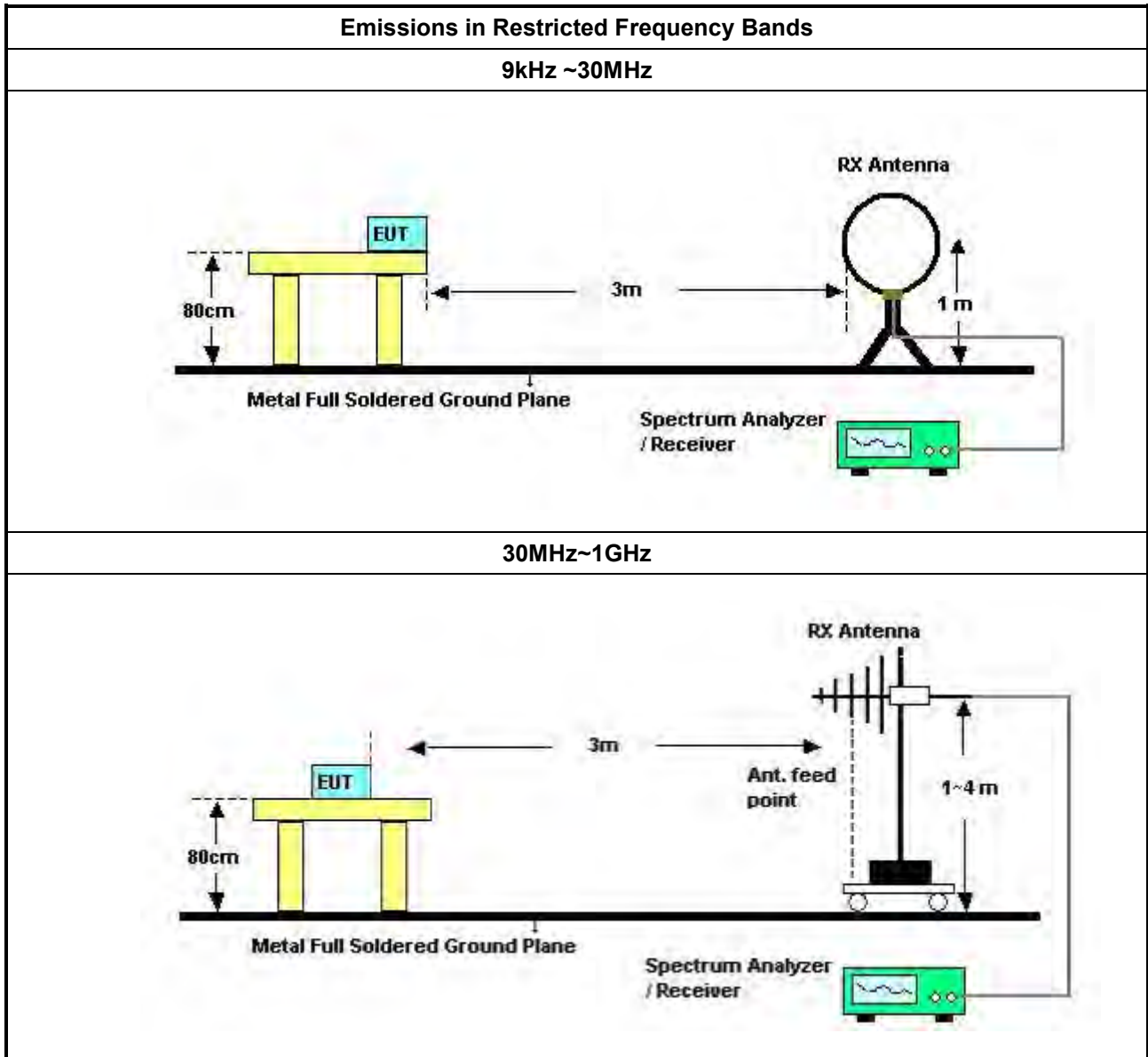

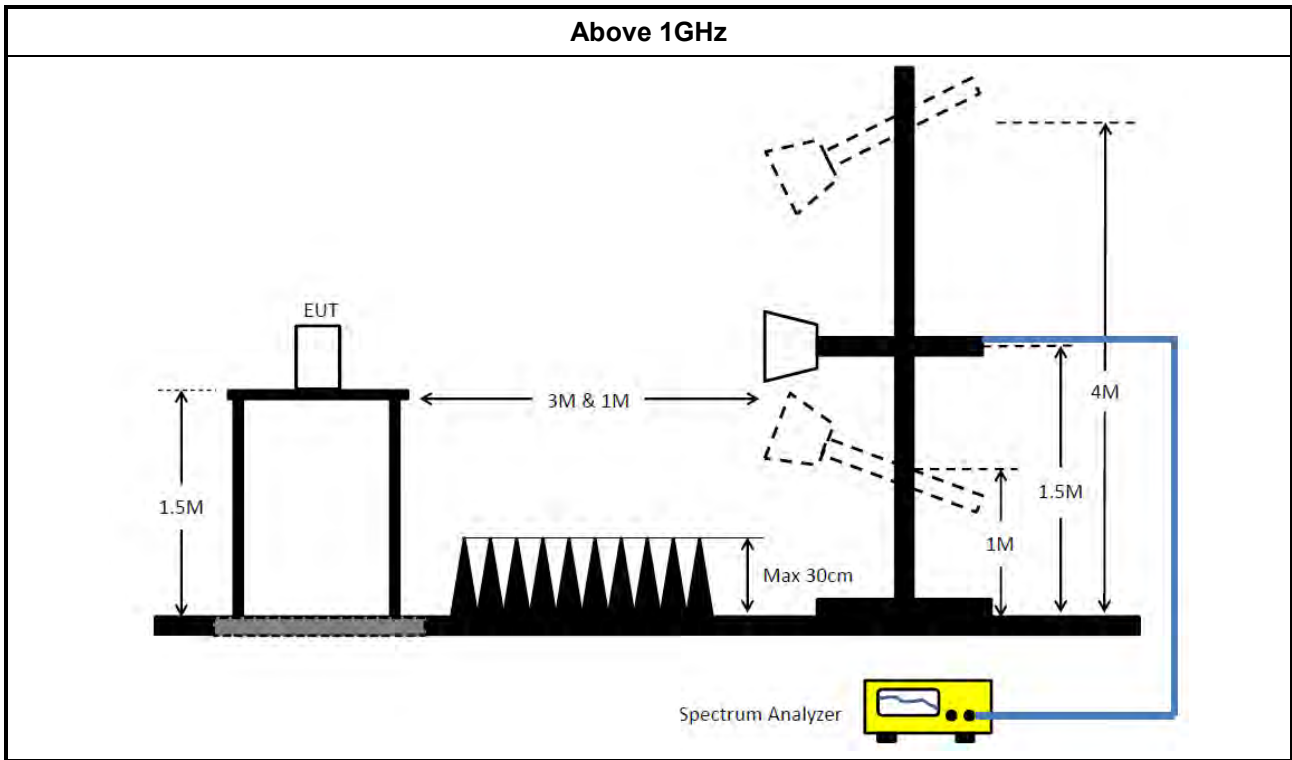

3.6.5 Test Result of Emissions in Restricted Frequency Bands (Below 30MHz)

The amplitude of spurious emissions which are attenuated by more than 20dB below the permissible value has no need to be reported. All amplitude of spurious emissions that are attenuated by more than 20 dB below the permissible value has no need to be reported.

3.6.6 Test Result of Emissions in Restricted Frequency Bands

Refer as Appendix F



4 Test Equipment and Calibration Data

Instrument for AC Conduction

Instrument	Manufacturer	Model No.	Serial No.	Spec.	Calibration Date	Calibration Due Date
EMC Receiver	R&S	ESR3	102051	9kHz ~ 3.6GHz	29/Apr/2017	28/Apr/2018
LISN	R&S	ENV216	101295	9kHz ~ 30MHz	15/Nov/2016	14/Nov/2017
RF Cable-CON	HUBER+SUHNER	RG213/U	0761183202000 1	9kHz ~ 30MHz	24/Oct/2016	23/Oct/2017
LISN (Support Unit)	EMCO	3810/2	9703-1839	9kHz ~ 30MHz	NCR	NCR
Impuls Begrenzer Pulse Limiter	R&S	ESH3-Z2	100921	10 kHz ~ 30 MHz	20/Oct/2016	19/Oct/2017

NCR : Non-Calibration Require

Instrument for Conducted Test

Instrument	Manufacturer	Model No.	Serial No.	Spec.	Calibration Date	Calibration Due Date
Spectrum Analyzer	R&S	FSV 40	101013	9kHz~40GHz	30/Dec/2016	29/Dec/2017
Power Sensor	Anritsu	MA2411B	0917017	300MHz ~ 40GHz	10/Feb/2017	09/Feb/2018
Power Meter	Anritsu	ML2495A	0949003	300MHz ~ 40GHz	10/Feb/2017	09/Feb/2018
Signal Generator	R&S	SMR40	100116	10MHz ~ 40GHz	21/Jul/2016	20/Jul/2017
Temp. and Humidity Chamber	Giant Force	GTH-225-20-SP- SD	MAA1112-007	-20 ~ 100°C	10/May/2017	09/May/2018
RF Cable-0.2m	HUBER+SUHNER	SUCOFLEX_104	MY10710/4	30MHz ~ 26.5GHz	02/Oct/2016	01/Oct/2017
RF Cable-0.2m	HUBER+SUHNER	SUCOFLEX_104	MY10709/4	30MHz ~ 26.5GHz	02/Oct/2016	01/Oct/2017
RF Cable-0.5m	HUBER+SUHNER	SUCOFLEX_104	MY10713/4	30MHz ~ 26.5GHz	02/Oct/2016	01/Oct/2017

Instrument for Radiated below 1GHz Test

Instrument	Manufacturer	Model No.	Serial No.	Spec.	Calibration Date	Calibration Due Date
3m Semi Anechoic Chamber	TDK	SAC-3M	03CH09-HY	30MHz ~ 1GHz	25/Apr/2017	24/Apr/2018
Amplifier	EMC	EMC9135	980232	9kHz~1GHz	25/Apr/2017	24/Apr/2018
Spectrum Analyzer	KEYSIGHT	N9010A	MY54200885	10Hz ~ 44GHz	04/Jul/2016	03/Jul/2017
Bilog Antenna	TESEQ	CBL 6111D	35418	30MHz~1GHz	01/Oct/2016	30/Sep/2017
Loop Antenna	R&S	HFH2-Z2	100330	9 kHz~30 MHz	10/Nov/2016	09/Nov/2017
RF Cable-R03m	Jye Bao	RG142	CB021	9kHz ~ 1GHz	23/Jul/2016	22/Jul/2017



Instrument for Radiated above 1GHz Test

Instrument	Manufacturer	Model No.	Serial No.	Spec.	Calibration Date	Calibration Due Date
3m Semi Anechoic Chamber	TDK	SAC-3M	03CH09-HY	30MHz ~ 1GHz	25/Apr/2017	24/Apr/2018
3m Semi Anechoic Chamber	TDK	SAC-3M	03CH09-HY	1GHz ~ 18GHz	27/Nov/2016	26/Nov/2017
Amplifier	Agilent	8449B	3008A02096	1GHz ~ 26.5GHz	25/Apr/2017	24/Apr/2018
Amplifier	EMC	EMC9135	980232	9kHz~1GHz	25/Apr/2017	24/Apr/2018
Spectrum Analyzer	KEYSIGHT	N9010A	MY54200885	10Hz ~ 44GHz	04/Jul/2016	03/Jul/2017
Bilog Antenna	TESEQ	CBL 6111D	35418	30MHz~1GHz	01/Oct/2016	30/Sep/2017
Horn Antenna	SCHWARZBECK	BBHA 9120D	BBHA9120D 1534	1GHz~18GHz	28/Apr/2017	27/Apr/2018
Loop Antenna	R&S	HFH2-Z2	100330	9 kHz~30 MHz	10/Nov/2016	09/Nov/2017
RF Cable-R03m	Jye Bao	RG142	CB021	9kHz ~ 1GHz	23/Jul/2016	22/Jul/2017
RF Cable-high	Jye Bao	RG142	03CH09-HY	1GHz ~ 40GHz	23/Jul/2016	22/Jul/2017



AC Power-line Conducted Emissions Result																																																																																																																				
Operating Mode	1	Power Phase	Neutral																																																																																																																	
Operating Function	USB Mode																																																																																																																			
<div style="text-align: right;">Date: 2017-07-04</div>																																																																																																																				
	<table border="1"> <thead> <tr> <th>Freq</th> <th>Level</th> <th>Over</th> <th>Limit</th> <th>Read</th> <th>LISN</th> <th>Cable</th> <th>Remark</th> </tr> <tr> <th>MHz</th> <th>dBuV</th> <th>dB</th> <th>dBuV</th> <th>dBuV</th> <th>dB</th> <th>dB</th> <th></th> </tr> </thead> <tbody> <tr><td>1</td><td>0.15</td><td>38.57</td><td>-17.34</td><td>55.91</td><td>28.75</td><td>9.60</td><td>0.22 Average</td></tr> <tr><td>2</td><td>0.15</td><td>51.68</td><td>-14.23</td><td>65.91</td><td>41.86</td><td>9.60</td><td>0.22 QP</td></tr> <tr><td>3</td><td>0.18</td><td>37.27</td><td>-17.40</td><td>54.67</td><td>27.37</td><td>9.64</td><td>0.26 Average</td></tr> <tr><td>4</td><td>0.18</td><td>49.02</td><td>-15.65</td><td>64.67</td><td>39.12</td><td>9.64</td><td>0.26 QP</td></tr> <tr><td>5</td><td>0.20</td><td>35.76</td><td>-17.84</td><td>53.60</td><td>25.79</td><td>9.67</td><td>0.30 Average</td></tr> <tr><td>6</td><td>0.20</td><td>46.35</td><td>-17.25</td><td>63.60</td><td>36.38</td><td>9.67</td><td>0.30 QP</td></tr> <tr><td>7</td><td>0.38</td><td>41.57</td><td>-6.75</td><td>48.32</td><td>31.82</td><td>9.63</td><td>0.12 Average</td></tr> <tr><td>8</td><td>0.38</td><td>44.90</td><td>-13.42</td><td>58.32</td><td>35.15</td><td>9.63</td><td>0.12 QP</td></tr> <tr><td>9 MAX</td><td>0.40</td><td>41.47</td><td>-6.33</td><td>47.80</td><td>31.74</td><td>9.63</td><td>0.10 Average</td></tr> <tr><td>10</td><td>0.40</td><td>43.98</td><td>-13.82</td><td>57.80</td><td>34.25</td><td>9.63</td><td>0.10 QP</td></tr> <tr><td>11</td><td>4.29</td><td>25.69</td><td>-20.31</td><td>46.00</td><td>15.87</td><td>9.71</td><td>0.11 Average</td></tr> <tr><td>12</td><td>4.29</td><td>32.51</td><td>-23.49</td><td>56.00</td><td>22.69</td><td>9.71</td><td>0.11 QP</td></tr> </tbody> </table>	Freq	Level	Over	Limit	Read	LISN	Cable	Remark	MHz	dBuV	dB	dBuV	dBuV	dB	dB		1	0.15	38.57	-17.34	55.91	28.75	9.60	0.22 Average	2	0.15	51.68	-14.23	65.91	41.86	9.60	0.22 QP	3	0.18	37.27	-17.40	54.67	27.37	9.64	0.26 Average	4	0.18	49.02	-15.65	64.67	39.12	9.64	0.26 QP	5	0.20	35.76	-17.84	53.60	25.79	9.67	0.30 Average	6	0.20	46.35	-17.25	63.60	36.38	9.67	0.30 QP	7	0.38	41.57	-6.75	48.32	31.82	9.63	0.12 Average	8	0.38	44.90	-13.42	58.32	35.15	9.63	0.12 QP	9 MAX	0.40	41.47	-6.33	47.80	31.74	9.63	0.10 Average	10	0.40	43.98	-13.82	57.80	34.25	9.63	0.10 QP	11	4.29	25.69	-20.31	46.00	15.87	9.71	0.11 Average	12	4.29	32.51	-23.49	56.00	22.69	9.71	0.11 QP			
Freq	Level	Over	Limit	Read	LISN	Cable	Remark																																																																																																													
MHz	dBuV	dB	dBuV	dBuV	dB	dB																																																																																																														
1	0.15	38.57	-17.34	55.91	28.75	9.60	0.22 Average																																																																																																													
2	0.15	51.68	-14.23	65.91	41.86	9.60	0.22 QP																																																																																																													
3	0.18	37.27	-17.40	54.67	27.37	9.64	0.26 Average																																																																																																													
4	0.18	49.02	-15.65	64.67	39.12	9.64	0.26 QP																																																																																																													
5	0.20	35.76	-17.84	53.60	25.79	9.67	0.30 Average																																																																																																													
6	0.20	46.35	-17.25	63.60	36.38	9.67	0.30 QP																																																																																																													
7	0.38	41.57	-6.75	48.32	31.82	9.63	0.12 Average																																																																																																													
8	0.38	44.90	-13.42	58.32	35.15	9.63	0.12 QP																																																																																																													
9 MAX	0.40	41.47	-6.33	47.80	31.74	9.63	0.10 Average																																																																																																													
10	0.40	43.98	-13.82	57.80	34.25	9.63	0.10 QP																																																																																																													
11	4.29	25.69	-20.31	46.00	15.87	9.71	0.11 Average																																																																																																													
12	4.29	32.51	-23.49	56.00	22.69	9.71	0.11 QP																																																																																																													
<p>Note 1: ">20dB" means emission levels that exceed the level of 20 dB below the applicable limit. Note 2: "N/F" means Nothing Found emissions (No emissions were detected.)</p>																																																																																																																				



AC Power-line Conducted Emissions Result			
Operating Mode	1	Power Phase	Line
Operating Function	USB Mode		
<div style="text-align: right;">Date: 2017-07-04</div> <p>The graph displays the AC power-line conducted emissions. The y-axis represents Level in dBuV, ranging from 0 to 80. The x-axis represents Frequency in MHz, ranging from 0.15 to 30. Two red lines indicate the limits: CNS/VCCI/CISPR-B (upper) and CNS/VCCI/CISPR-B AV (lower). The blue line shows the measured emission levels, which are mostly below the limits, with a peak at 0.38 MHz labeled '7 MAX'.</p>			
	Freq	Level	Over Limit
	MHz	dBuV	dB
	Line	dBuV	dB
	Read Level	LISN Factor	Cable Loss
	dBuV	dB	dB
	Remark		
1	0.15	38.46	-17.45
2	0.15	51.66	-14.25
3	0.18	36.59	-18.02
4	0.18	48.31	-16.30
5	0.20	35.51	-18.06
6	0.20	46.27	-17.30
7 MAX	0.38	36.36	-11.88
8	0.38	41.12	-17.12
9	4.23	25.11	-20.89
10	4.23	32.90	-23.10
11	6.20	29.88	-20.12
12	6.20	34.39	-25.61

Note 1: ">20dB" means emission levels that exceed the level of 20 dB below the applicable limit.
 Note 2: "N/F" means Nothing Found emissions (No emissions were detected.)



Summary

Mode	Max-N dB (Hz)	Max-OBW (Hz)	ITU-Code	Min-N dB (Hz)	Min-OBW (Hz)
802.11b_(1Mbps)_2TX	-	-	-	-	-
2.4-2.4835GHz	10.025M	13.493M	13M5G1D	9.525M	13.243M
802.11g_(6Mbps)_2TX	-	-	-	-	-
2.4-2.4835GHz	15.05M	16.467M	16M5D1D	13.15M	16.167M
802.11n HT20_Nss1,(MCS0)_2TX	-	-	-	-	-
2.4-2.4835GHz	15.075M	17.541M	17M5D1D	13.775M	17.266M
802.11n HT40_Nss1,(MCS0)_2TX	-	-	-	-	-
2.4-2.4835GHz	35M	35.882M	35M9D1D	27.8M	35.632M

Max-N dB = Maximum 6dB down bandwidth; **Max-OBW** = Maximum 99% occupied bandwidth;
Min-N dB = Minimum 6dB down bandwidth; **Min-OBW** = Minimum 99% occupied bandwidth;

Result

Mode	Result	Limit (Hz)	Port 1-N dB (Hz)	Port 1-OBW (Hz)	Port 2-N dB (Hz)	Port 2-OBW (Hz)
802.11b_(1Mbps)_2TX	-	-	-	-	-	-
2412MHz_TnomVnom	Pass	500k	10.025M	13.343M	10.025M	13.443M
2437MHz_TnomVnom	Pass	500k	9.525M	13.293M	9.55M	13.243M
2462MHz_TnomVnom	Pass	500k	9.525M	13.268M	9.55M	13.493M
802.11g_(6Mbps)_2TX	-	-	-	-	-	-
2412MHz_TnomVnom	Pass	500k	15.05M	16.192M	15M	16.242M
2437MHz_TnomVnom	Pass	500k	13.15M	16.342M	15.025M	16.467M
2462MHz_TnomVnom	Pass	500k	15.05M	16.167M	14.4M	16.217M
802.11n HT20_Nss1,(MCS0)_2TX	-	-	-	-	-	-
2412MHz_TnomVnom	Pass	500k	14.95M	17.266M	14.075M	17.341M
2437MHz_TnomVnom	Pass	500k	13.825M	17.416M	13.775M	17.541M
2462MHz_TnomVnom	Pass	500k	15.025M	17.291M	15.075M	17.316M
802.11n HT40_Nss1,(MCS0)_2TX	-	-	-	-	-	-
2422MHz_TnomVnom	Pass	500k	32.55M	35.632M	32.55M	35.632M
2437MHz_TnomVnom	Pass	500k	35M	35.782M	27.8M	35.882M
2452MHz_TnomVnom	Pass	500k	33.8M	35.782M	32.55M	35.732M

Port X-N dB = Port X 6dB down bandwidth; **Port X-OBW** = Port X 99% occupied bandwidth;

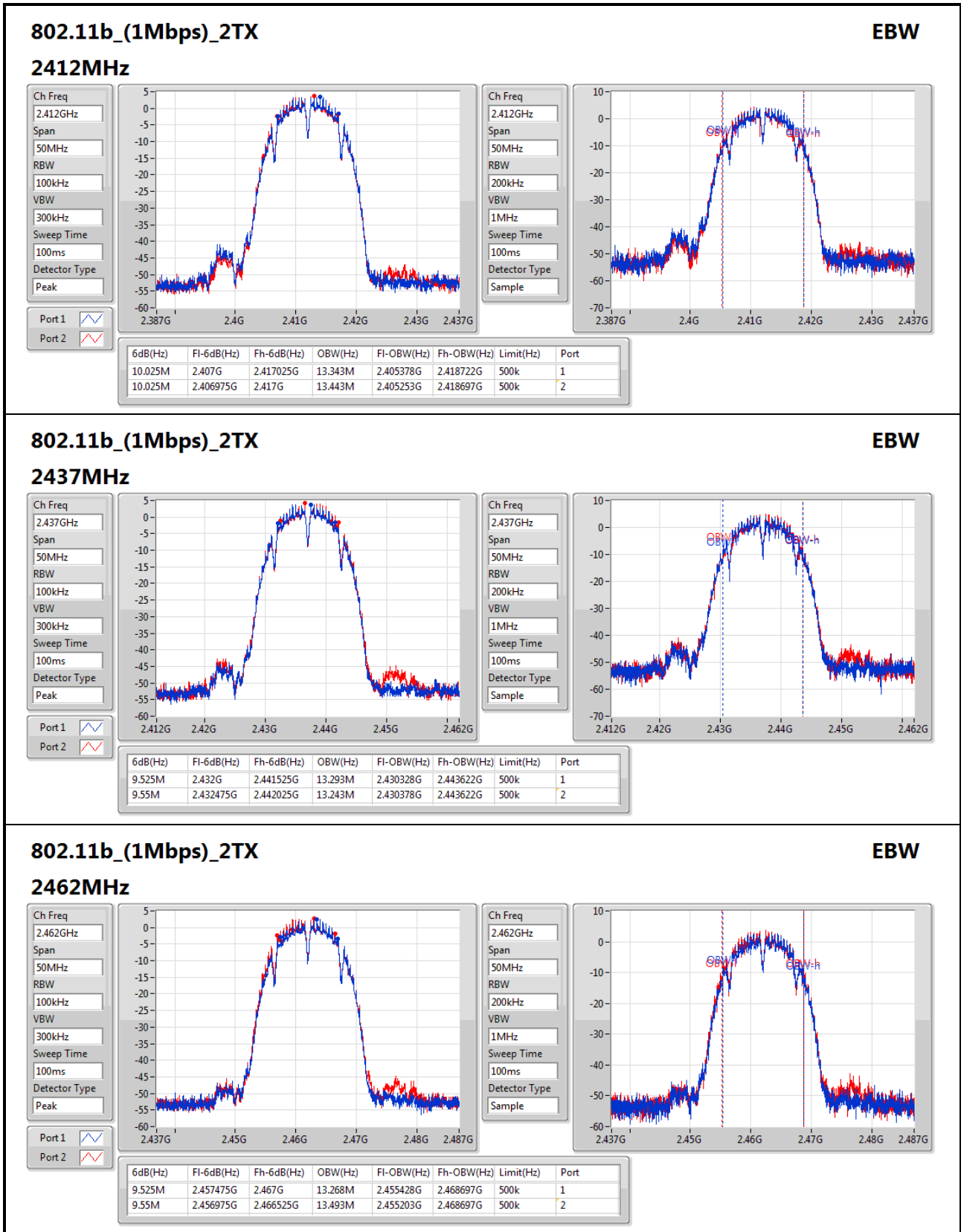

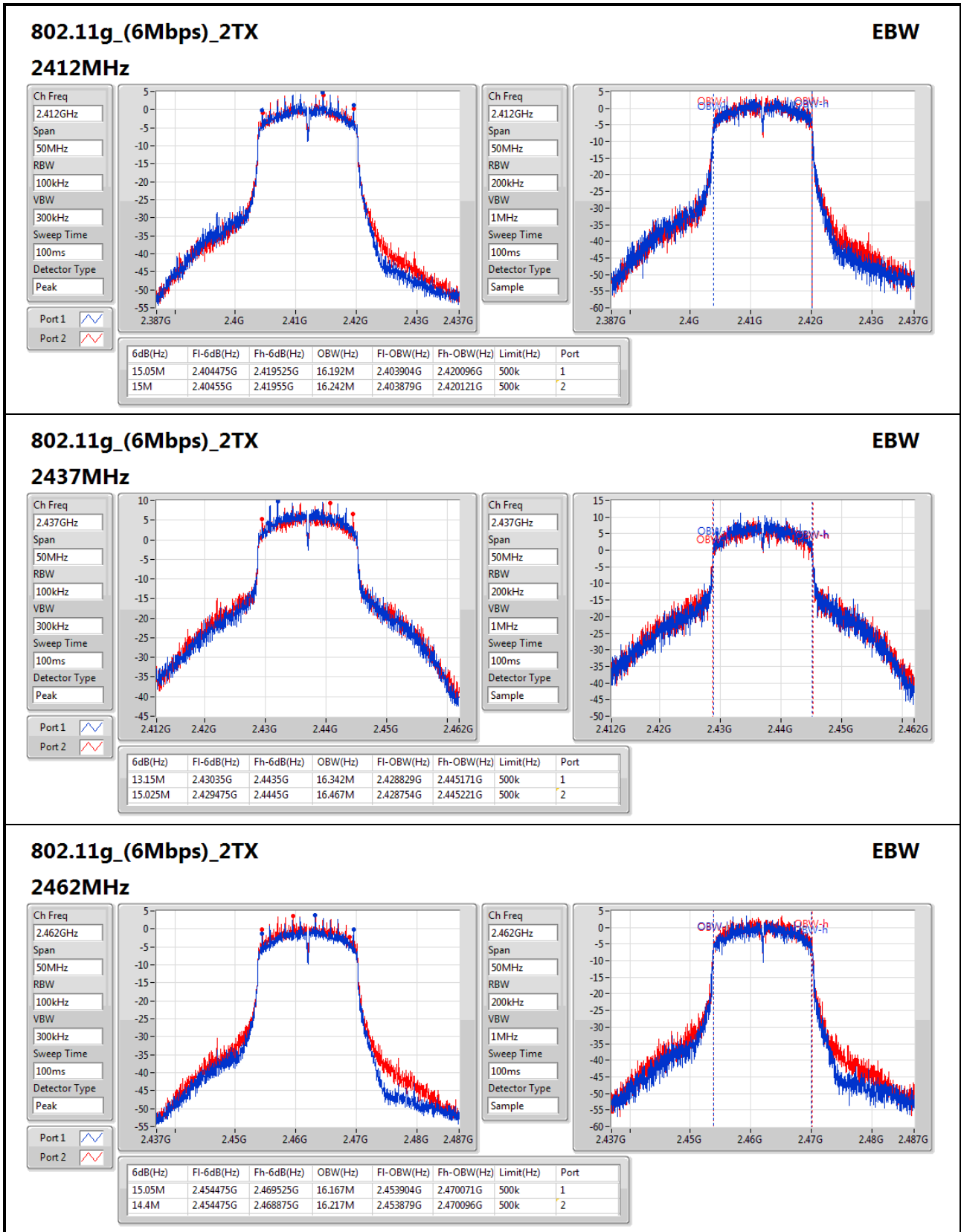

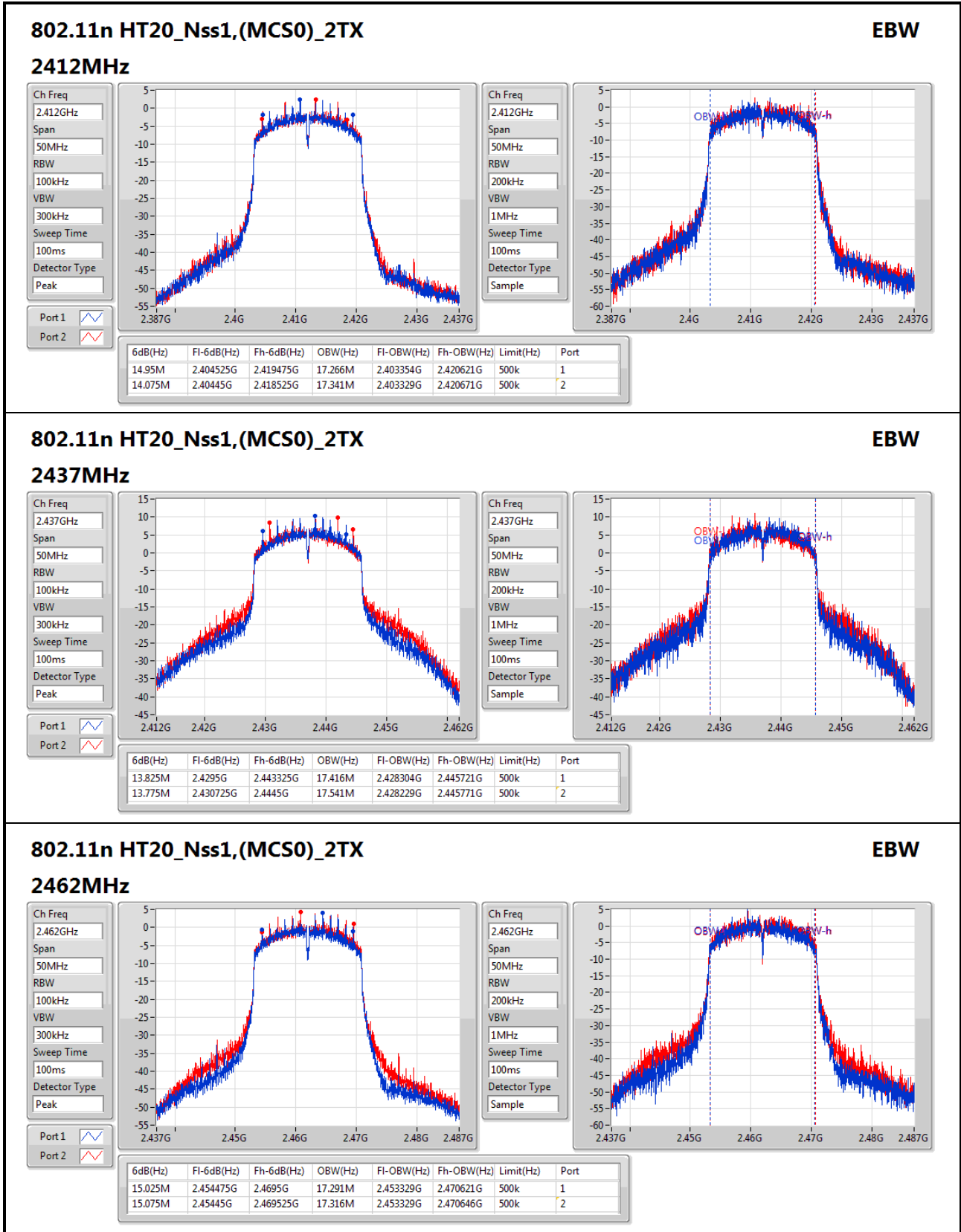

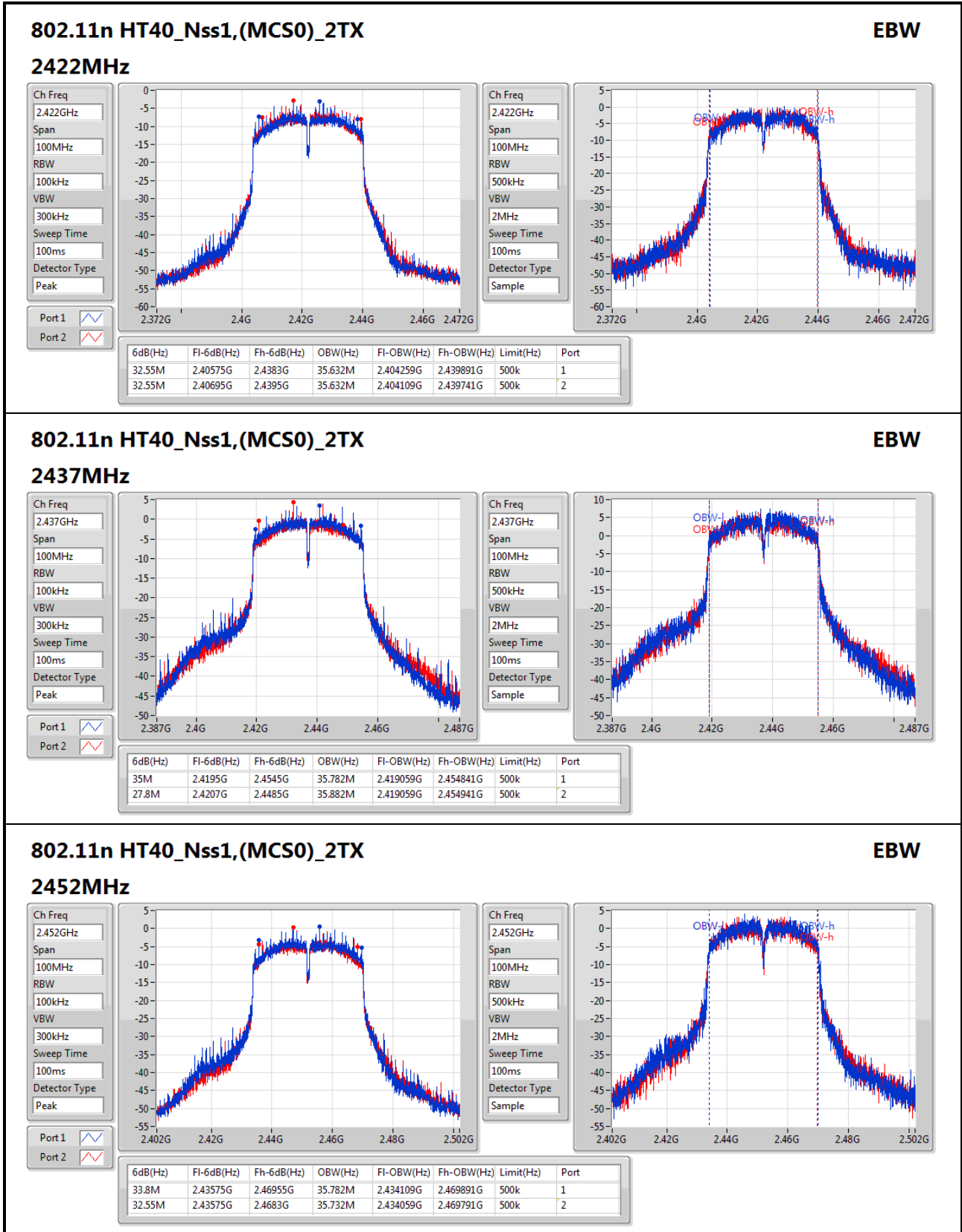



Summary

Mode	Total Power (dBm)	Total Power (W)
802.11b_(1Mbps)_2TX	-	-
2.4-2.4835GHz	17.46	0.05572
802.11g_(6Mbps)_2TX	-	-
2.4-2.4835GHz	24.00	0.25119
802.11n HT20_Nss1,(MCS0)_2TX	-	-
2.4-2.4835GHz	23.88	0.24434
802.11n HT40_Nss1,(MCS0)_2TX	-	-
2.4-2.4835GHz	20.45	0.11092

Result

Mode	Result	DG (dBi)	Port 1 (dBm)	Port 2 (dBm)	Total Power (dBm)	Power Limit (dBm)
802.11b_(1Mbps)_2TX	-	-	-	-	-	-
2412MHz_TnomVnom	Pass	3.31	13.85	14.98	17.46	30.00
2437MHz_TnomVnom	Pass	3.31	14.24	14.14	17.20	30.00
2462MHz_TnomVnom	Pass	3.31	12.70	13.53	16.14	30.00
802.11g_(6Mbps)_2TX	-	-	-	-	-	-
2412MHz_TnomVnom	Pass	3.31	15.37	15.51	18.45	30.00
2437MHz_TnomVnom	Pass	3.31	21.26	20.70	24.00	30.00
2462MHz_TnomVnom	Pass	3.31	14.34	15.24	17.83	30.00
802.11n HT20_Nss1,(MCS0)_2TX	-	-	-	-	-	-
2412MHz_TnomVnom	Pass	3.31	12.93	13.46	16.22	30.00
2437MHz_TnomVnom	Pass	3.31	21.12	20.60	23.88	30.00
2462MHz_TnomVnom	Pass	3.31	14.58	15.58	18.12	30.00
802.11n HT40_Nss1,(MCS0)_2TX	-	-	-	-	-	-
2422MHz_TnomVnom	Pass	3.31	10.69	10.85	13.78	30.00
2437MHz_TnomVnom	Pass	3.31	17.60	17.28	20.45	30.00
2452MHz_TnomVnom	Pass	3.31	14.20	13.83	17.03	30.00

DG = Directional Gain; Port X = Port X output power



Summary

Mode	PD (dBm/RBW)
802.11b_(1Mbps)_2TX 2.4-2.4835GHz	- -8.85
802.11g_(6Mbps)_2TX 2.4-2.4835GHz	- -3.38
802.11n HT20_Nss1,(MCS0)_2TX 2.4-2.4835GHz	- -3.31
802.11n HT40_Nss1,(MCS0)_2TX 2.4-2.4835GHz	- -9.91

RBW=3kHz.

Result

Mode	Result	DG (dBi)	Port 1 (dBm/RBW)	Port 2 (dBm/RBW)	PD (dBm/RBW)	PD Limit (dBm/RBW)
802.11b_(1Mbps)_2TX	-	-	-	-	-	-
2412MHz_TnomVnom	Pass	6.21	-10.56	-10.85	-8.85	7.79
2437MHz_TnomVnom	Pass	6.21	-10.38	-10.15	-9.35	7.79
2462MHz_TnomVnom	Pass	6.21	-11.30	-11.06	-9.83	7.79
802.11g_(6Mbps)_2TX	-	-	-	-	-	-
2412MHz_TnomVnom	Pass	6.21	-10.67	-9.77	-8.63	7.79
2437MHz_TnomVnom	Pass	6.21	-5.23	-5.52	-3.38	7.79
2462MHz_TnomVnom	Pass	6.21	-10.33	-10.16	-8.10	7.79
802.11n HT20_Nss1,(MCS0)_2TX	-	-	-	-	-	-
2412MHz_TnomVnom	Pass	6.21	-11.89	-13.03	-11.44	7.79
2437MHz_TnomVnom	Pass	6.21	-5.38	-4.02	-3.31	7.79
2462MHz_TnomVnom	Pass	6.21	-11.28	-9.74	-8.94	7.79
802.11n HT40_Nss1,(MCS0)_2TX	-	-	-	-	-	-
2422MHz_TnomVnom	Pass	6.21	-16.85	-17.69	-15.96	7.79
2437MHz_TnomVnom	Pass	6.21	-11.35	-11.20	-9.91	7.79
2452MHz_TnomVnom	Pass	6.21	-13.77	-15.05	-12.54	7.79

DG = Directional Gain; RBW=3kHz;

PD = trace bin-by-bin of each transmits port summing can be performed maximum power density; **Port X** = Port X power density;

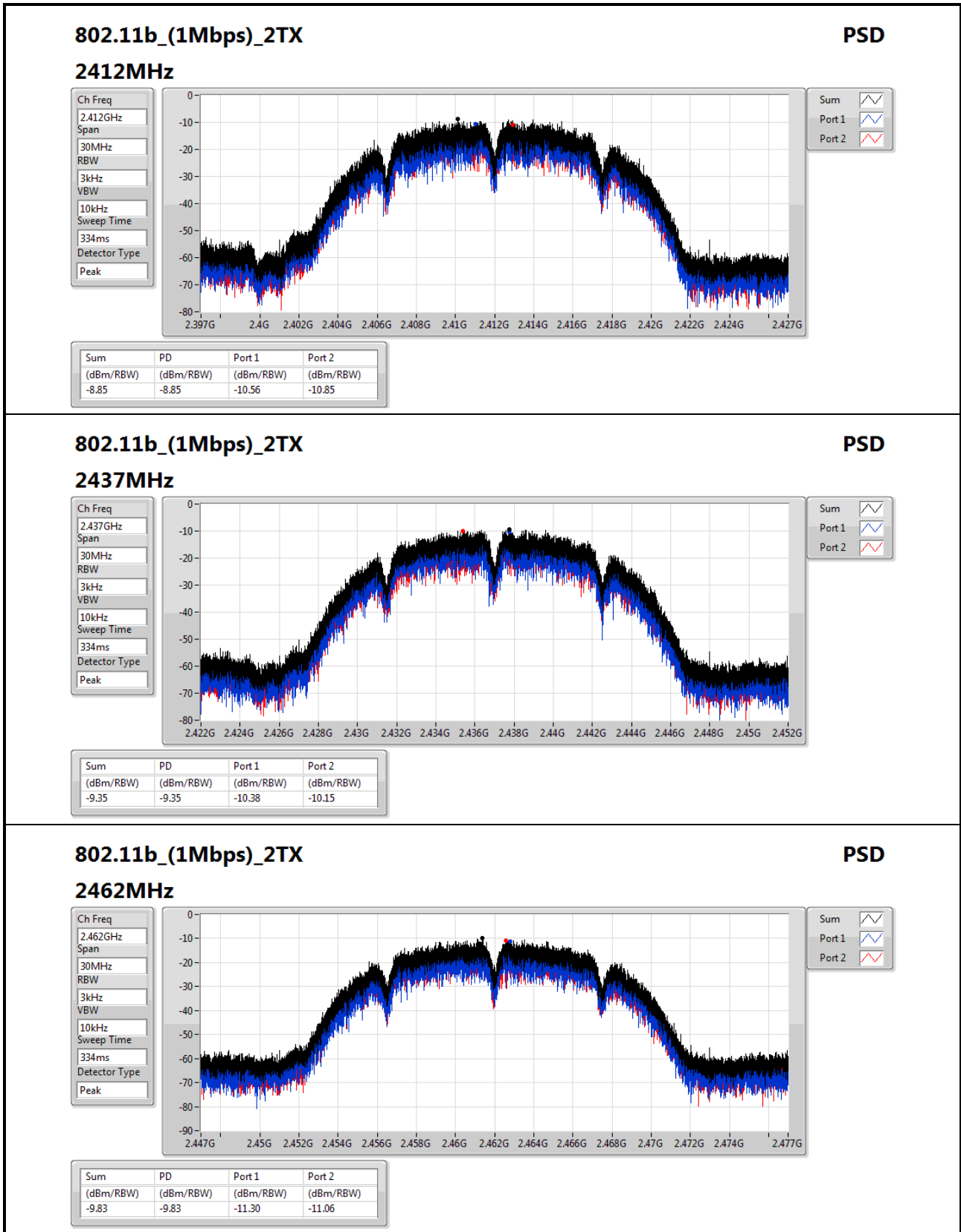
802.11b_(1Mbps)_2TX
PSD

2462MHz

Ch Freq
2.462GHz

Span
30MHz

RBW
3kHz

VBW
10kHz

Sweep Time
334ms

Detector Type
Peak

Sum

Port 1

Port 2

Sum	PD	Port 1	Port 2
(dBm/RBW)	(dBm/RBW)	(dBm/RBW)	(dBm/RBW)
-9.83	-9.83	-11.30	-11.06

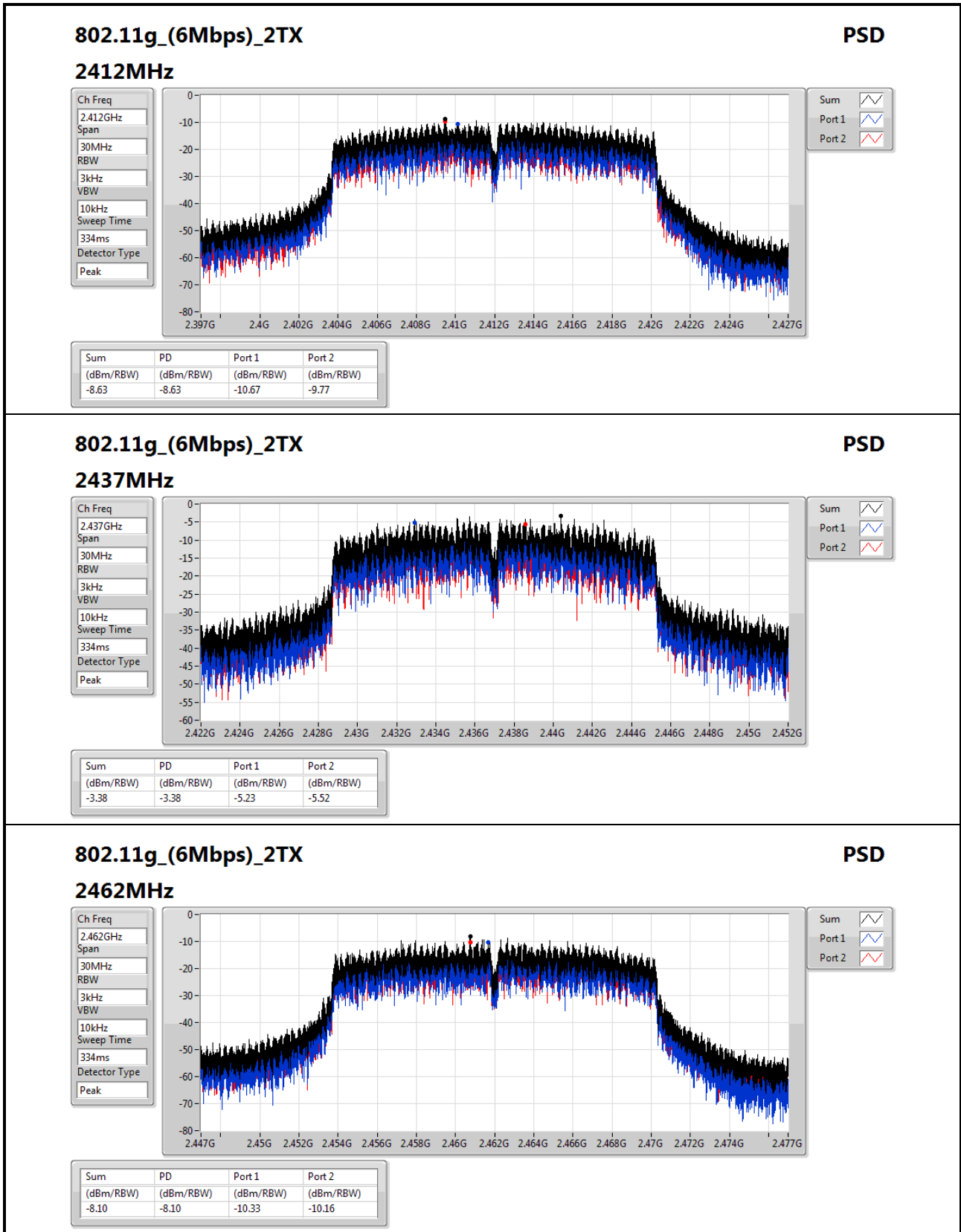

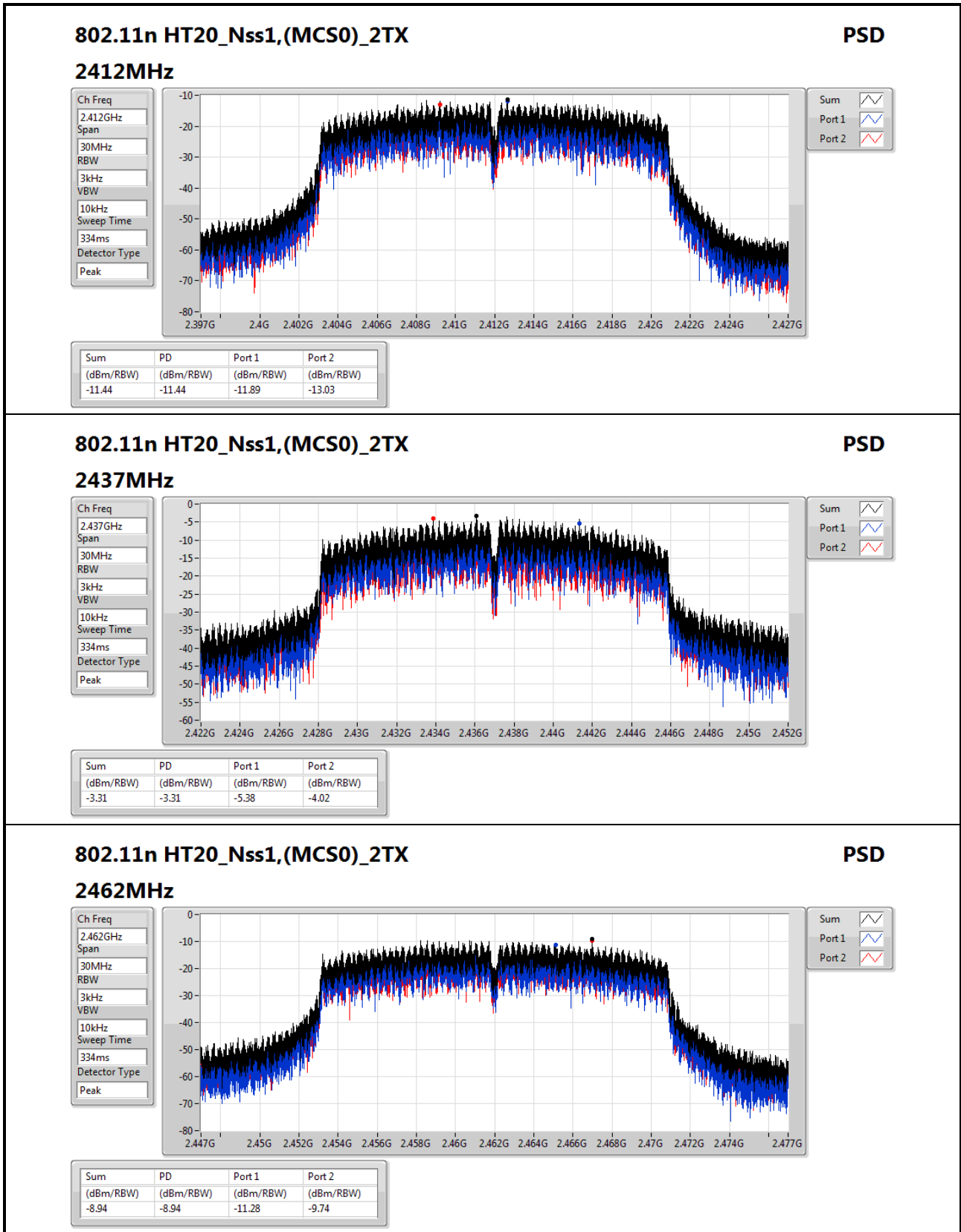

802.11n HT20_Nss1,(MCS0)_2TX

2462MHz

PSD

Ch Freq
2.462GHz

Span
30MHz

RBW
3kHz

VBW
10kHz

Sweep Time
334ms

Detector Type
Peak

Sum

Port 1

Port 2

Sum	PD	Port 1	Port 2
(dBm/RBW)	(dBm/RBW)	(dBm/RBW)	(dBm/RBW)
-8.94	-8.94	-11.28	-9.74

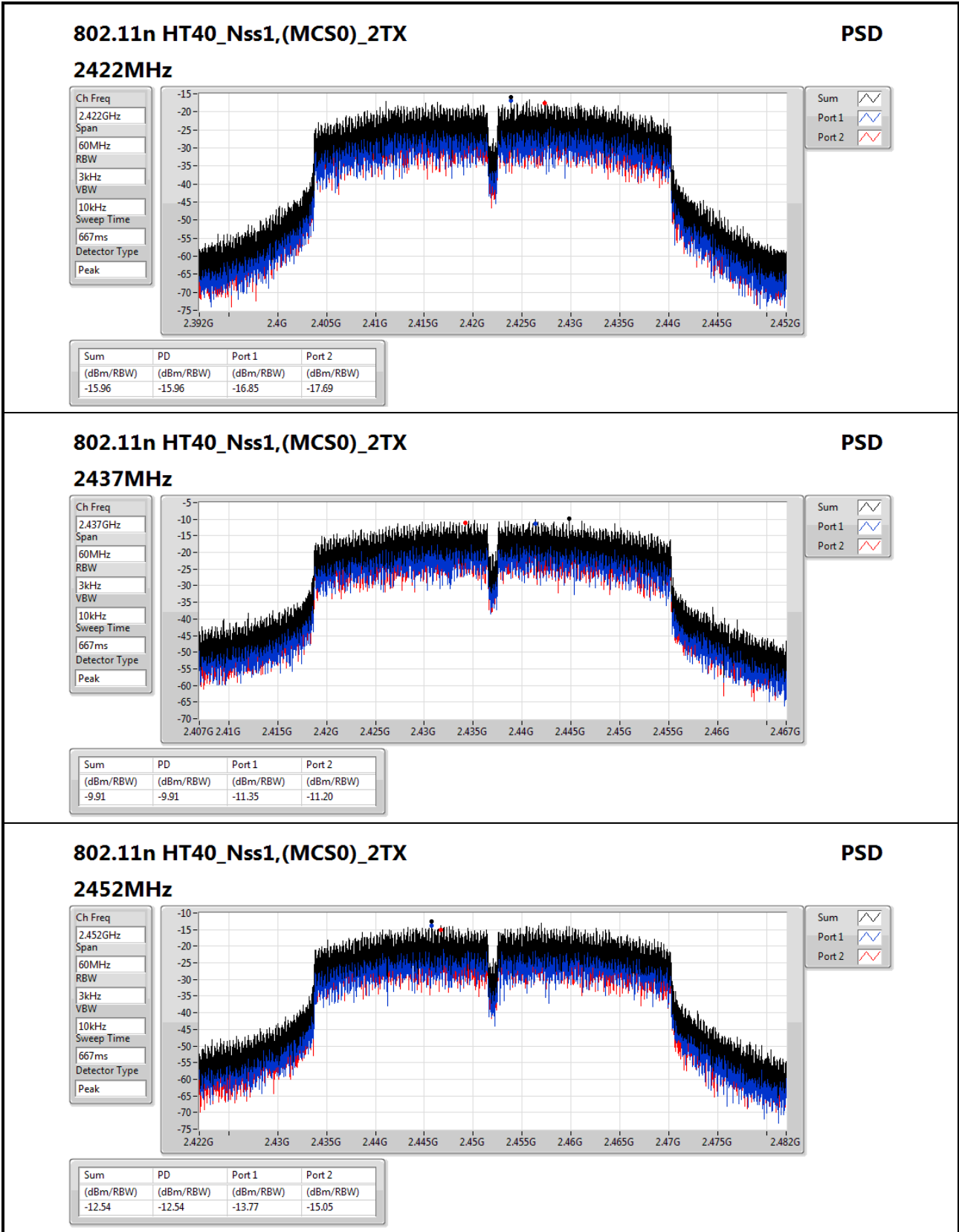

802.11n HT40_Nss1,(MCS0)_2TX

2452MHz

PSD

Ch Freq
2.452GHz

Span
60MHz

RBW
3kHz

VBW
10kHz

Sweep Time
667ms

Detector Type
Peak



Sum

Port 1

Port 2

Sum	PD	Port 1	Port 2
(dBm/RBW)	(dBm/RBW)	(dBm/RBW)	(dBm/RBW)
-12.54	-12.54	-13.77	-15.05



Summary

Mode	Result	Ref (Hz)	Ref (dBm)	Limit (dBm)	Freq (Hz)	Level (dBm)	Freq (Hz)	Level (dBm)	Freq (Hz)	Level (dBm)	Freq (Hz)	Level (dBm)	Port
802.11n HT40_Nss1,(MCS0)_2TX	-	-	-	-	-	-	-	-	-	-	-	-	-
2.4-2.4835GHz	Pass	2.442084G	3.89	-26.11	2.14596G	-54.87	2.39968G	-30.89	2.48574G	-37.95	6.958249G	-48.97	2

Result

Mode	Result	Ref (Hz)	Ref (dBm)	Limit (dBm)	Freq (Hz)	Level (dBm)	Freq (Hz)	Level (dBm)	Freq (Hz)	Level (dBm)	Freq (Hz)	Level (dBm)	Port
802.11b_(1Mbps)_2TX	-	-	-	-	-	-	-	-	-	-	-	-	-
2412MHz_TnomVnom	Pass	2.410521G	4.60	-25.40	597.355M	-49.67	2.39856G	-42.25	2.51302G	-53.94	6.985085G	-48.94	1
2412MHz_TnomVnom	Pass	2.410521G	4.60	-25.40	1.988365G	-54.77	2.39704G	-41.18	2.4859G	-54.66	6.948561G	-47.63	2
2437MHz_TnomVnom	Pass	2.410521G	4.60	-25.40	597.355M	-51.40	2.39056G	-52.96	2.48886G	-51.66	6.928894G	-46.94	1
2437MHz_TnomVnom	Pass	2.410521G	4.60	-25.40	1.91264G	-55.14	2.39288G	-52.76	2.48438G	-53.46	6.912037G	-49.74	2
2462MHz_TnomVnom	Pass	2.410521G	4.60	-25.40	597.355M	-50.66	2.3912G	-54.71	2.50934G	-52.21	6.920465G	-47.55	1
2462MHz_TnomVnom	Pass	2.410521G	4.60	-25.40	2.02681G	-55.21	2.39552G	-54.98	2.51534G	-52.24	6.971037G	-47.87	2
802.11g_(6Mbps)_2TX	-	-	-	-	-	-	-	-	-	-	-	-	-
2412MHz_TnomVnom	Pass	2.431897G	9.68	-20.32	597.355M	-49.17	2.39992G	-27.79	2.48478G	-54.14	6.965418G	-48.55	1
2412MHz_TnomVnom	Pass	2.431897G	9.68	-20.32	2.044285G	-54.48	2.3996G	-30.34	2.4915G	-53.91	6.976657G	-48.74	2
2437MHz_TnomVnom	Pass	2.431897G	9.68	-20.32	597.355M	-50.40	2.39864G	-43.27	2.48438G	-47.72	6.369791G	-48.64	1
2437MHz_TnomVnom	Pass	2.431897G	9.68	-20.32	1.939435G	-54.11	2.39944G	-44.29	2.48446G	-48.60	6.948561G	-48.70	2
2462MHz_TnomVnom	Pass	2.431897G	9.68	-20.32	597.355M	-50.84	2.39776G	-54.84	2.48374G	-48.67	6.948561G	-47.91	1
2462MHz_TnomVnom	Pass	2.431897G	9.68	-20.32	1.937105G	-54.95	2.39976G	-54.01	2.48382G	-47.73	6.985085G	-48.71	2
802.11n HT20_Nss1,(MCS0)_2TX	-	-	-	-	-	-	-	-	-	-	-	-	-
2412MHz_TnomVnom	Pass	2.440748G	8.93	-21.07	597.355M	-49.81	2.39704G	-33.65	2.51126G	-54.42	6.962609G	-49.03	1
2412MHz_TnomVnom	Pass	2.440748G	8.93	-21.07	2.198065G	-54.36	2.39984G	-34.33	2.5099G	-54.04	6.37541G	-47.38	2
2437MHz_TnomVnom	Pass	2.440748G	8.93	-21.07	597.355M	-50.68	2.39928G	-45.15	2.48598G	-48.31	6.937323G	-48.21	1
2437MHz_TnomVnom	Pass	2.440748G	8.93	-21.07	2.030305G	-53.92	2.39992G	-44.60	2.48374G	-49.75	6.819321G	-49.53	2
2462MHz_TnomVnom	Pass	2.440748G	8.93	-21.07	597.355M	-50.38	2.39856G	-53.44	2.48406G	-48.45	6.937323G	-47.41	1
2462MHz_TnomVnom	Pass	2.440748G	8.93	-21.07	1.89633G	-55.20	2.39616G	-52.84	2.4847G	-46.27	6.993514G	-48.41	2
802.11n HT40_Nss1,(MCS0)_2TX	-	-	-	-	-	-	-	-	-	-	-	-	-
2422MHz_TnomVnom	Pass	2.442084G	3.89	-26.11	596.775M	-51.62	2.39968G	-34.03	2.48462G	-52.96	6.972272G	-48.34	1
2422MHz_TnomVnom	Pass	2.442084G	3.89	-26.11	1.7704G	-55.16	2.39952G	-33.12	2.48398G	-53.53	6.983491G	-47.26	2
2437MHz_TnomVnom	Pass	2.442084G	3.89	-26.11	597.92M	-50.16	2.39936G	-31.31	2.48574G	-39.99	6.899354G	-48.93	1
2437MHz_TnomVnom	Pass	2.442084G	3.89	-26.11	2.14596G	-54.87	2.39968G	-30.89	2.48574G	-37.95	6.958249G	-48.97	2
2452MHz_TnomVnom	Pass	2.442084G	3.89	-26.11	597.92M	-50.25	2.39648G	-52.80	2.48574G	-39.96	6.949836G	-48.33	1
2452MHz_TnomVnom	Pass	2.442084G	3.89	-26.11	2.044055G	-53.74	2.3984G	-52.54	2.48446G	-37.97	6.977881G	-48.05	2

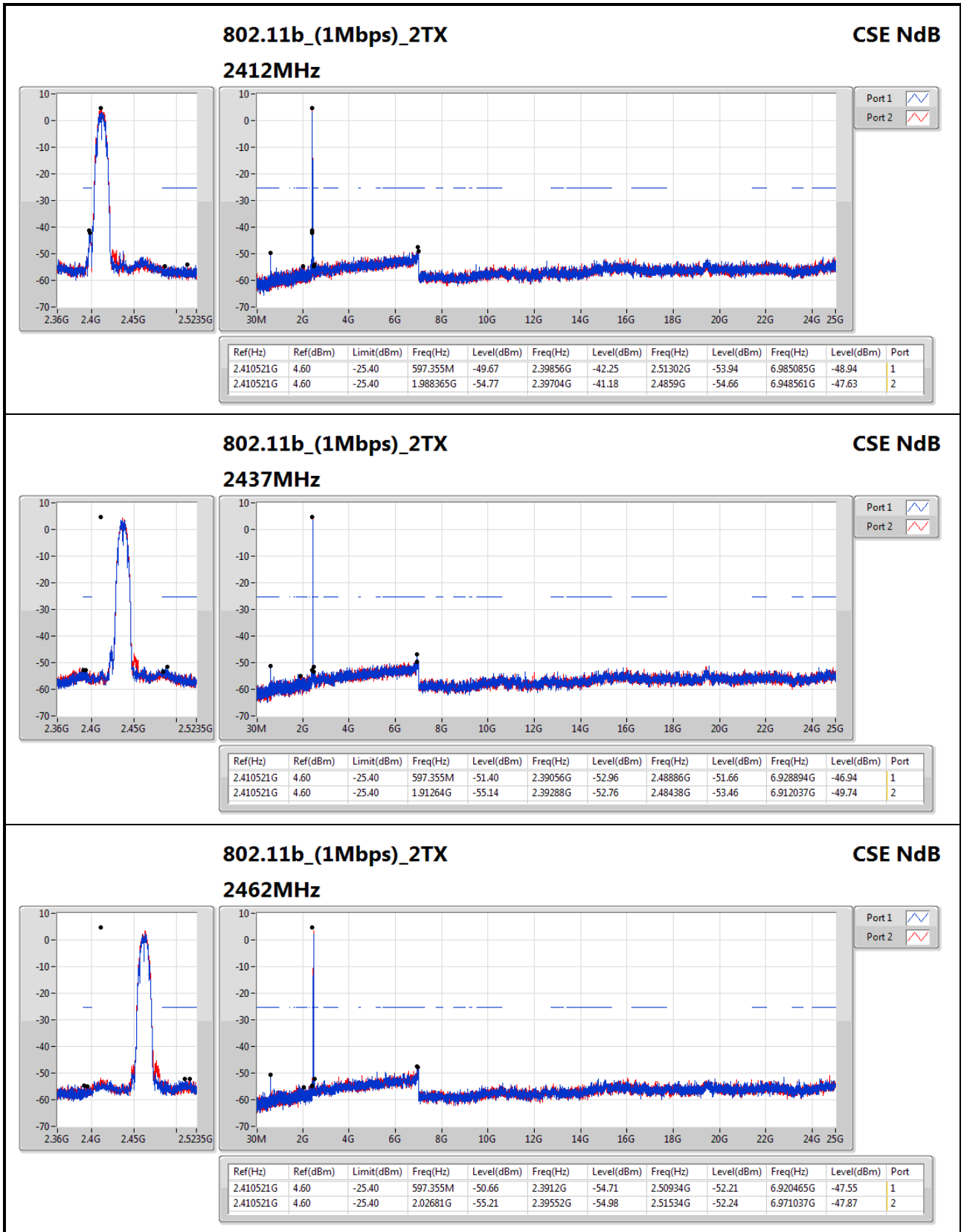

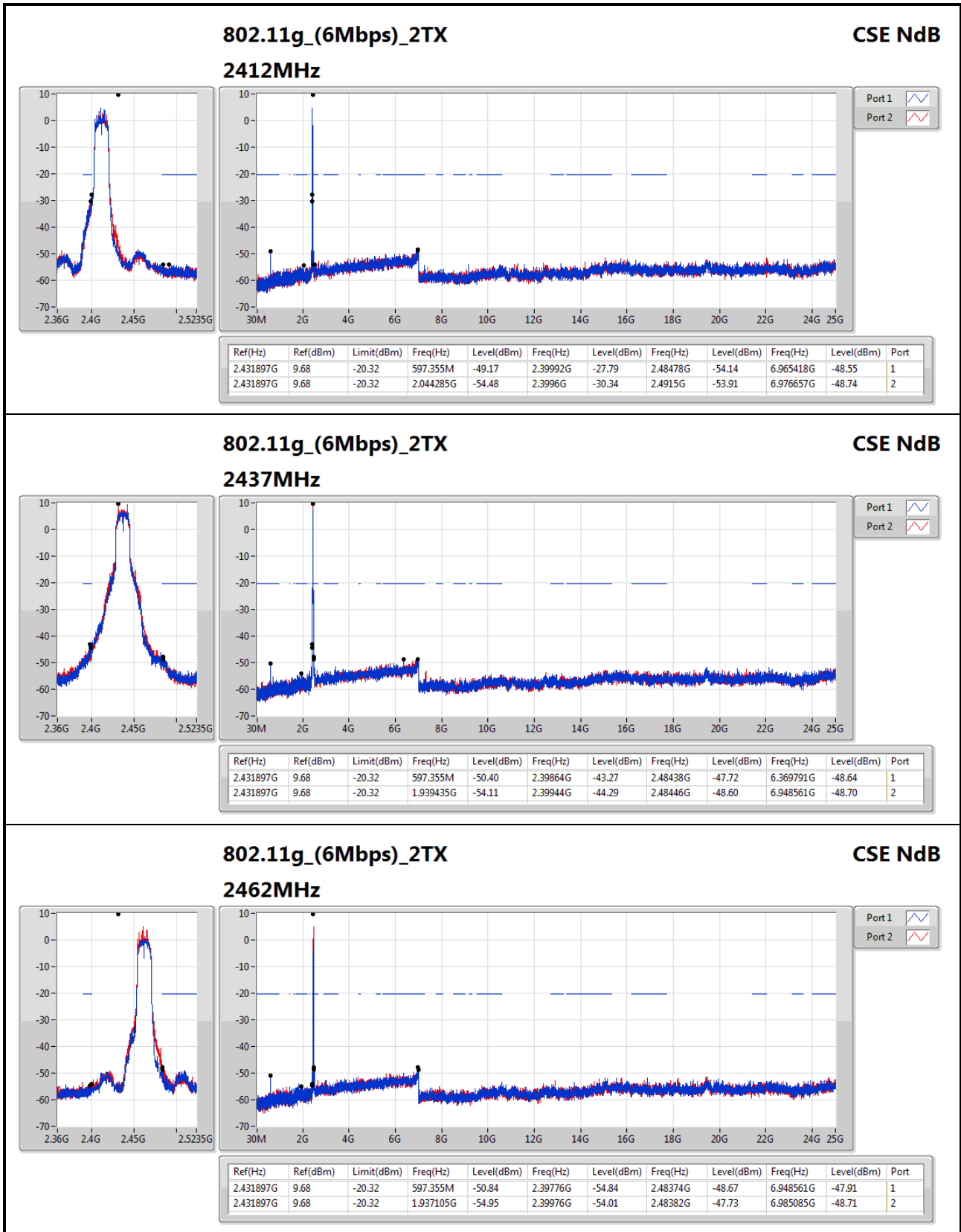

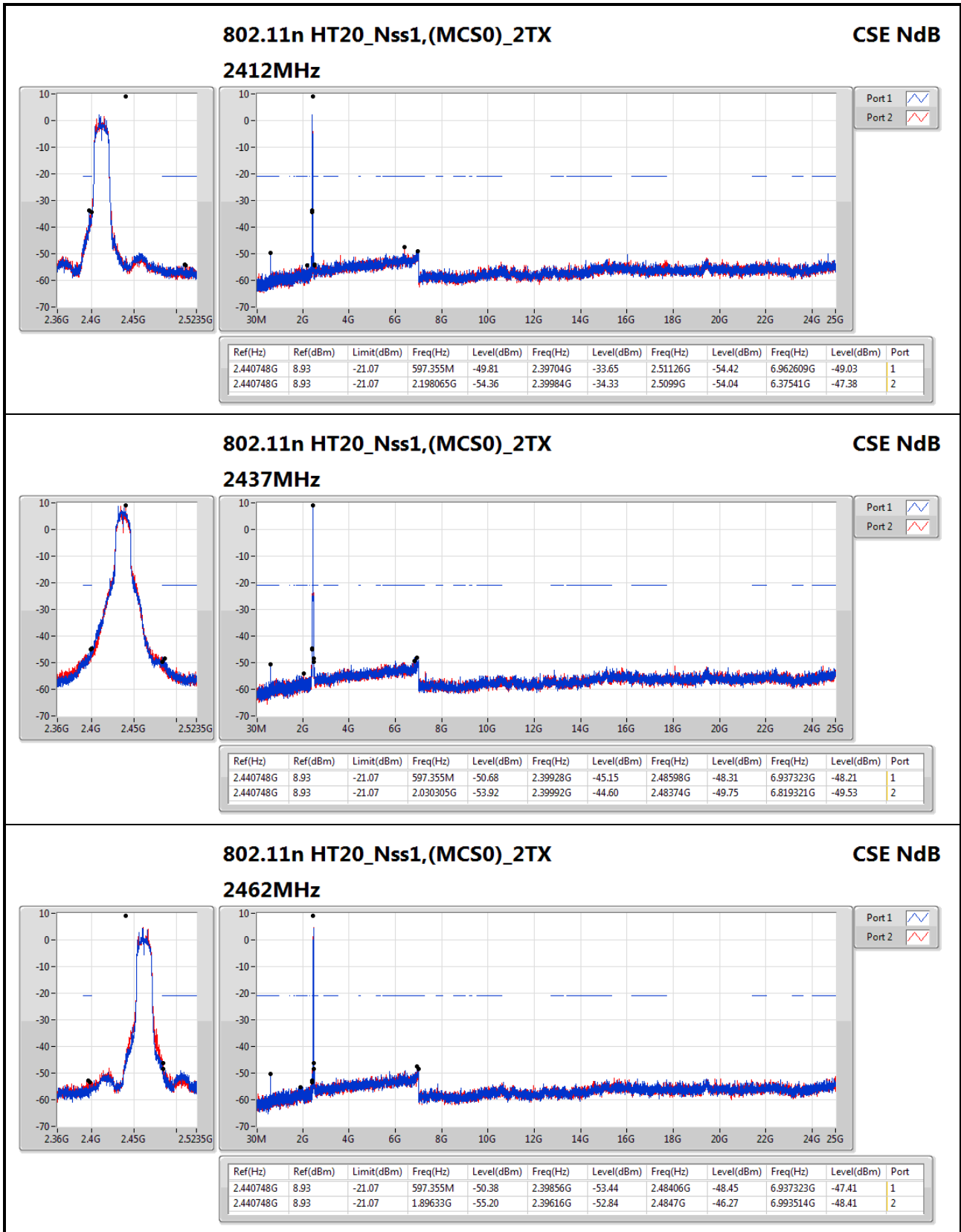

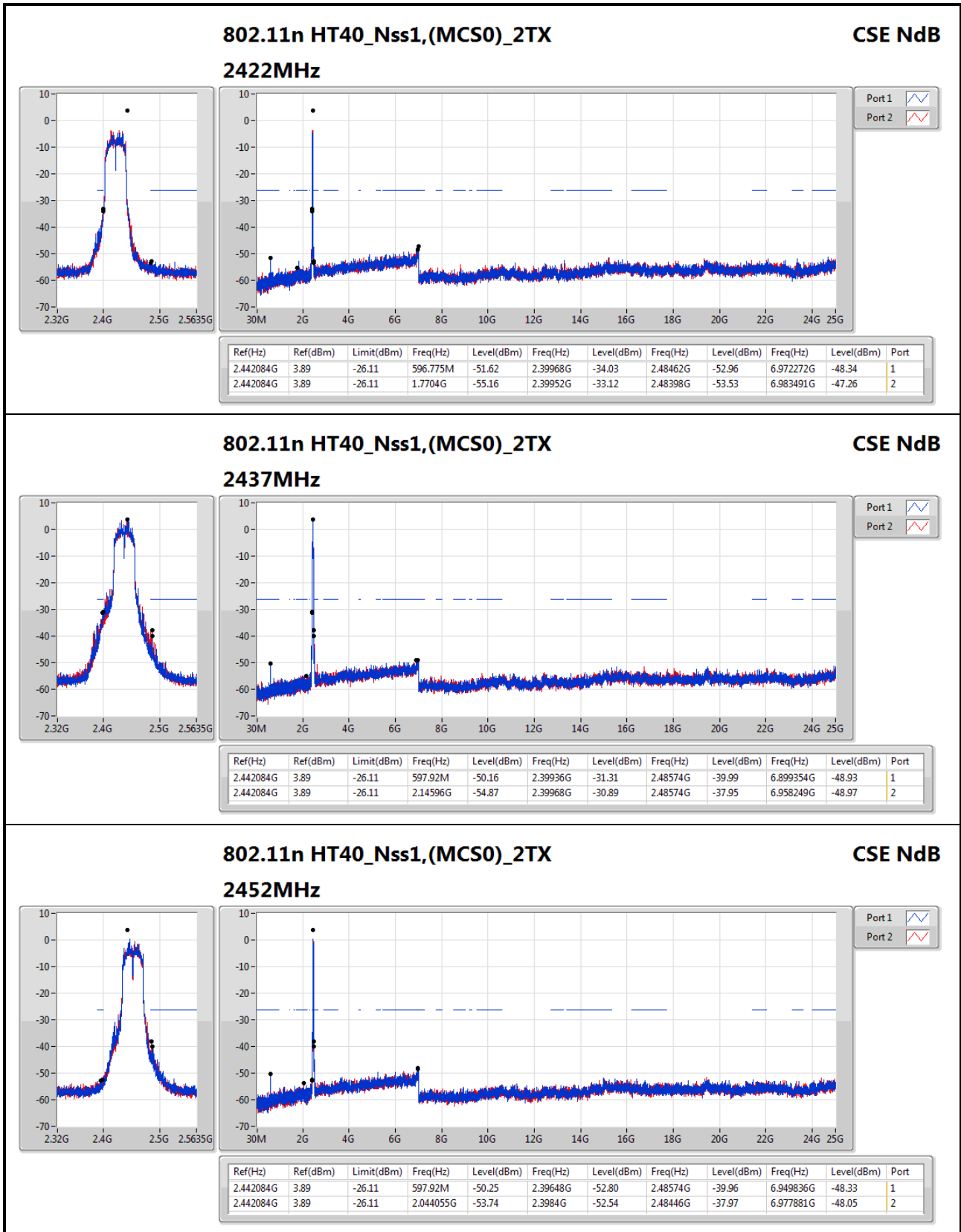



Summary

Mode	Result	Type	Freq (Hz)	Level (dBuV/m)	Limit (dBuV/m)	Margin (dB)	Factor (dB)	Dist (m)	Condition	Azimuth (°)	Height (m)	Comments
Mode 1	Pass	QP	499.48M	42.85	46.00	-3.15	-10.16	3	Horizontal	10	1.00	-



Result

Mode	Result	Type	Freq (Hz)	Level (dBuV/m)	Limit (dBuV/m)	Margin (dB)	Factor (dB)	Dist (m)	Condition	Azimuth (°)	Height (m)	Comments
Mode 1	Pass	PK	97.9M	33.33	43.50	-10.17	-20.58	3	Horizontal	360	1.00	-
Mode 1	Pass	PK	165.8M	37.66	43.50	-5.84	-19.41	3	Horizontal	360	1.00	-
Mode 1	Pass	PK	249.22M	34.91	46.00	-11.09	-16.48	3	Horizontal	360	1.00	-
Mode 1	Pass	PK	375.32M	41.59	46.00	-4.41	-13.40	3	Horizontal	360	1.00	-
Mode 1	Pass	PK	951.5M	41.00	46.00	-5.00	-2.41	3	Horizontal	360	1.00	-
Mode 1	Pass	QP	499.48M	42.85	46.00	-3.15	-10.16	3	Horizontal	10	1.00	-
Mode 1	Pass	PK	41.64M	33.22	40.00	-6.78	-18.66	3	Vertical	0	1.00	-
Mode 1	Pass	PK	99.84M	32.30	43.50	-11.20	-20.36	3	Vertical	0	1.00	-
Mode 1	Pass	PK	142.52M	35.45	43.50	-8.05	-18.37	3	Vertical	0	1.00	-
Mode 1	Pass	PK	344.28M	34.46	46.00	-11.54	-14.29	3	Vertical	0	1.00	-
Mode 1	Pass	PK	499.48M	37.80	46.00	-8.20	-10.16	3	Vertical	0	1.00	-
Mode 1	Pass	PK	598.42M	35.83	46.00	-10.17	-8.62	3	Vertical	0	1.00	-

Radiated-below 1GHz_Mode 1

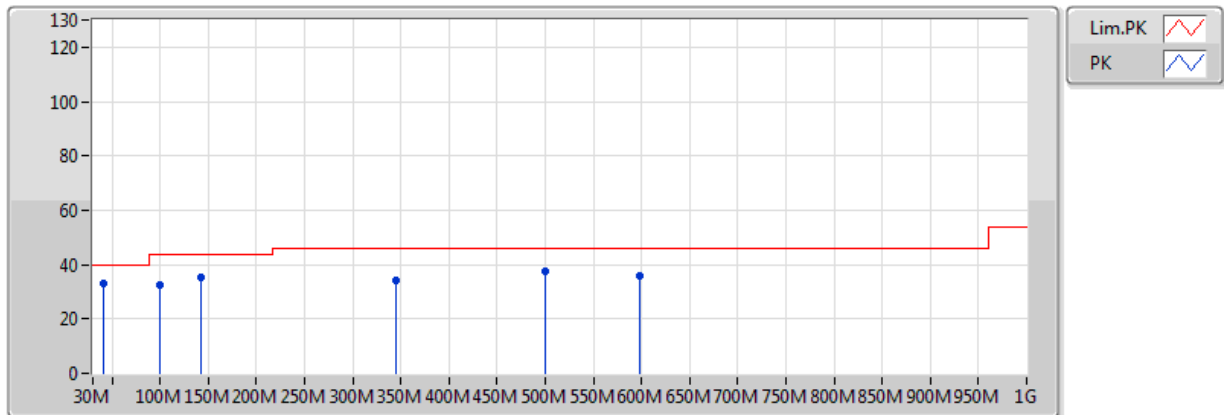

EUT : Z axis

Type	Freq (Hz)	Level (dBuV/m)	Limit (dBuV/m)	Margin (dB)	Factor (dB)	Dist (m)	Condition	Azimuth (°)	Height (m)	Comments	Raw (dBuV)	AF (dB)	CL (dB)	PA (dB)
PK	41.64M	33.22	40.00	-6.78	-18.66	3	Vertical	0	1.00	-	51.88	17.49	1.08	37.22
PK	99.84M	32.30	43.50	-11.20	-20.36	3	Vertical	0	1.00	-	52.66	14.83	1.61	36.80
PK	142.52M	35.45	43.50	-8.05	-18.37	3	Vertical	0	1.00	-	53.82	16.28	1.97	36.62
PK	344.28M	34.46	46.00	-11.54	-14.29	3	Vertical	0	1.00	-	48.75	19.13	3.09	36.51
PK	499.48M	37.80	46.00	-8.20	-10.16	3	Vertical	0	1.00	-	47.96	22.82	3.94	36.92
PK	598.42M	35.83	46.00	-10.17	-8.62	3	Vertical	0	1.00	-	44.45	24.45	4.12	37.19



Radiated-below 1GHz_Mode 1

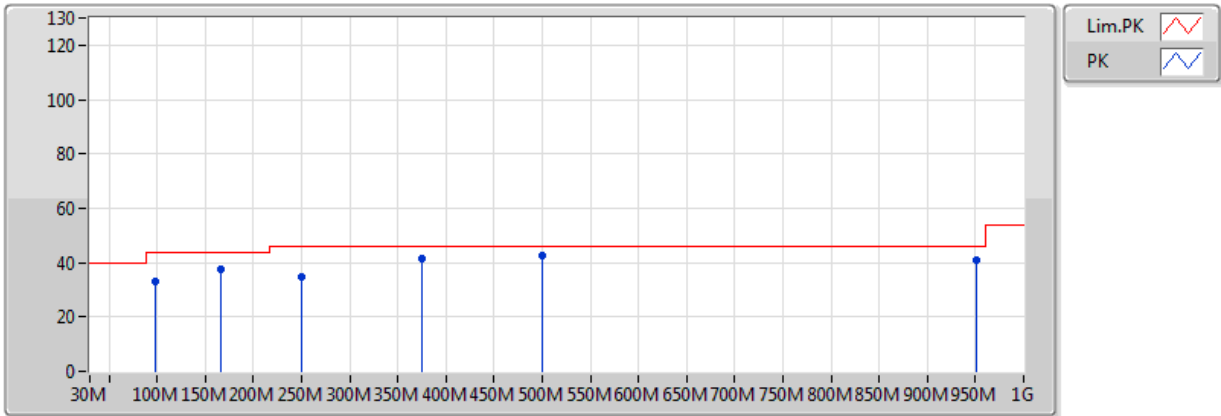

EUT : Z axis

Type	Freq (Hz)	Level (dBuV/m)	Limit (dBuV/m)	Margin (dB)	Factor (dB)	Dist (m)	Condition	Azimuth (°)	Height (m)	Comments	Raw (dBuV)	AF (dB)	CL (dB)	PA (dB)
PK	97.9M	33.33	43.50	-10.17	-20.58	3	Horizontal	360	1.00	-	53.91	14.64	1.59	36.81
PK	165.8M	37.66	43.50	-5.84	-19.41	3	Horizontal	360	1.00	-	57.07	15.00	2.12	36.53
PK	249.22M	34.91	46.00	-11.09	-16.48	3	Horizontal	360	1.00	-	51.39	17.37	2.56	36.41
PK	375.32M	41.59	46.00	-4.41	-13.40	3	Horizontal	360	1.00	-	54.99	19.96	3.22	36.57
PK	951.5M	41.00	46.00	-5.00	-2.41	3	Horizontal	360	1.00	-	43.41	29.49	5.43	37.33
QP	499.48M	42.85	46.00	-3.15	-10.16	3	Horizontal	10	1.00	-	53.01	22.82	3.94	36.92



Summary

Mode	Result	Type	Freq (Hz)	Level (dBuV/m)	Limit (dBuV/m)	Margin (dB)	Factor (dB)	Dist (m)	Pol. (H/V)	Azimuth (°)	Height (m)	Comments
802.11b_(1Mbps)_2TX	-	-	-	-	-	-	-	-	-	-	-	-
2.4-2.4835GHz	Pass	AV	4.874G	53.86	54.00	-0.14	2.55	3	V	213	1.03	-



Result

Mode	Result	Type	Freq (Hz)	Level (dBuV/m)	Limit (dBuV/m)	Margin (dB)	Factor (dB)	Dist (m)	Pol. (H/V)	Azimuth (°)	Height (m)	Comments
802.11b_(1Mbps)_2TX	-	-	-	-	-	-	-	-	-	-	-	-
2412MHz	Pass	AV	2.3882G	47.08	54.00	-6.92	31.16	3	H	94	3.56	-
2412MHz	Pass	AV	2.4132G	101.69	Inf	-Inf	31.26	3	H	94	3.56	-
2412MHz	Pass	PK	2.3862G	57.47	74.00	-16.53	31.16	3	H	94	3.56	-
2412MHz	Pass	PK	2.413G	104.47	Inf	-Inf	31.26	3	H	94	3.56	-
2412MHz	Pass	AV	2.388G	46.76	54.00	-7.24	31.16	3	V	35	3.69	-
2412MHz	Pass	AV	2.411G	98.90	Inf	-Inf	31.25	3	V	35	3.69	-
2412MHz	Pass	PK	2.3814G	58.18	74.00	-15.82	31.14	3	V	35	3.69	-
2412MHz	Pass	PK	2.412G	101.70	Inf	-Inf	31.26	3	V	35	3.69	-
2412MHz	Pass	AV	4.824G	51.60	54.00	-2.40	2.48	3	H	178	3.61	-
2412MHz	Pass	PK	4.824G	53.11	74.00	-20.89	2.48	3	H	178	3.61	-
2412MHz	Pass	AV	4.824G	53.49	54.00	-0.51	2.48	3	V	204	1.00	-
2412MHz	Pass	PK	4.824G	55.97	74.00	-18.03	2.48	3	V	204	1.00	-
2437MHz	Pass	AV	2.389998G	47.18	54.00	-6.82	31.17	3	H	131	3.53	-
2437MHz	Pass	AV	2.4358G	101.18	Inf	-Inf	31.35	3	H	131	3.53	-
2437MHz	Pass	AV	2.4842G	47.53	54.00	-6.47	31.53	3	H	131	3.53	-
2437MHz	Pass	PK	2.3762G	57.91	74.00	-16.09	31.12	3	H	131	3.53	-
2437MHz	Pass	PK	2.4354G	103.95	Inf	-Inf	31.34	3	H	131	3.53	-
2437MHz	Pass	PK	2.4894G	57.80	74.00	-16.20	31.55	3	H	131	3.53	-
2437MHz	Pass	AV	2.387G	46.90	54.00	-7.10	31.16	3	V	4	3.69	-
2437MHz	Pass	AV	2.4358G	100.46	Inf	-Inf	31.35	3	V	4	3.69	-
2437MHz	Pass	AV	2.483502G	47.52	54.00	-6.48	31.53	3	V	4	3.69	-
2437MHz	Pass	PK	2.3814G	57.97	74.00	-16.03	31.14	3	V	4	3.69	-
2437MHz	Pass	PK	2.4358G	103.26	Inf	-Inf	31.35	3	V	4	3.69	-
2437MHz	Pass	PK	2.4842G	58.69	74.00	-15.31	31.53	3	V	4	3.69	-
2437MHz	Pass	AV	4.874G	51.25	54.00	-2.75	2.55	3	H	179	3.69	-
2437MHz	Pass	PK	4.874G	54.38	74.00	-19.62	2.55	3	H	179	3.69	-
2437MHz	Pass	AV	4.874G	53.86	54.00	-0.14	2.55	3	V	213	1.03	-
2437MHz	Pass	PK	4.874G	55.48	74.00	-18.52	2.55	3	V	213	1.03	-
2462MHz	Pass	AV	2.461G	96.55	Inf	-Inf	31.44	3	H	314	3.03	-
2462MHz	Pass	AV	2.4982G	47.41	54.00	-6.59	31.58	3	H	314	3.03	-
2462MHz	Pass	PK	2.461G	99.32	Inf	-Inf	31.44	3	H	314	3.03	-
2462MHz	Pass	PK	2.4968G	58.63	74.00	-15.37	31.58	3	H	314	3.03	-
2462MHz	Pass	AV	2.4608G	98.26	Inf	-Inf	31.44	3	V	353	2.70	-
2462MHz	Pass	AV	2.4836G	47.69	54.00	-6.31	31.53	3	V	353	2.70	-
2462MHz	Pass	PK	2.461G	100.98	Inf	-Inf	31.44	3	V	353	2.70	-
2462MHz	Pass	PK	2.4916G	58.01	74.00	-15.99	31.56	3	V	353	2.70	-
2462MHz	Pass	AV	4.924G	45.77	54.00	-8.23	2.63	3	H	175	2.81	-
2462MHz	Pass	PK	4.924G	50.52	74.00	-23.48	2.63	3	H	175	2.81	-
2462MHz	Pass	AV	4.924G	53.61	54.00	-0.39	2.63	3	V	23	3.69	-
2462MHz	Pass	PK	4.924G	55.84	74.00	-18.16	2.63	3	V	23	3.69	-
802.11g_(6Mbps)_2TX	-	-	-	-	-	-	-	-	-	-	-	-
2412MHz	Pass	AV	2.3898G	53.57	54.00	-0.43	31.17	3	H	95	3.56	-
2412MHz	Pass	AV	2.414G	100.37	Inf	-Inf	31.26	3	H	95	3.56	-
2412MHz	Pass	PK	2.3894G	64.48	74.00	-9.52	31.17	3	H	95	3.56	-
2412MHz	Pass	PK	2.4136G	108.02	Inf	-Inf	31.26	3	H	95	3.56	-
2412MHz	Pass	AV	2.39G	53.36	54.00	-0.64	31.17	3	V	29	3.69	-
2412MHz	Pass	AV	2.41G	98.94	Inf	-Inf	31.25	3	V	29	3.69	-
2412MHz	Pass	PK	2.3896G	64.54	74.00	-9.46	31.17	3	V	29	3.69	-



RSE TX above 1GHz Result

Appendix F.2

Mode	Result	Type	Freq (Hz)	Level (dBuV/m)	Limit (dBuV/m)	Margin (dB)	Factor (dB)	Dist (m)	Pol. (H/V)	Azimuth (°)	Height (m)	Comments
2412MHz	Pass	PK	2.4148G	107.24	Inf	-Inf	31.27	3	V	29	3.69	-
2412MHz	Pass	AV	4.824G	38.29	54.00	-15.71	2.48	3	H	171	3.69	-
2412MHz	Pass	PK	4.824G	53.33	74.00	-20.67	2.48	3	H	171	3.69	-
2412MHz	Pass	AV	4.824G	44.52	54.00	-9.48	2.48	3	V	337	3.69	-
2412MHz	Pass	PK	4.824G	58.48	74.00	-15.52	2.48	3	V	337	3.69	-
2437MHz	Pass	AV	2.3886G	53.38	54.00	-0.62	31.17	3	H	288	3.53	-
2437MHz	Pass	AV	2.4362G	105.42	Inf	-Inf	31.35	3	H	288	3.53	-
2437MHz	Pass	AV	2.483502G	53.12	54.00	-0.88	31.53	3	H	288	3.53	-
2437MHz	Pass	PK	2.3894G	67.77	74.00	-6.23	31.17	3	H	288	3.53	-
2437MHz	Pass	PK	2.4366G	114.03	Inf	-Inf	31.35	3	H	288	3.53	-
2437MHz	Pass	PK	2.483502G	67.94	74.00	-6.06	31.53	3	H	288	3.53	-
2437MHz	Pass	AV	2.3886G	53.12	54.00	-0.88	31.17	3	V	189	2.93	-
2437MHz	Pass	AV	2.4378G	103.35	Inf	-Inf	31.35	3	V	189	2.93	-
2437MHz	Pass	AV	2.483502G	53.59	54.00	-0.41	31.53	3	V	189	2.93	-
2437MHz	Pass	PK	2.389G	66.89	74.00	-7.11	31.17	3	V	189	2.93	-
2437MHz	Pass	PK	2.4362G	111.73	Inf	-Inf	31.35	3	V	189	2.93	-
2437MHz	Pass	PK	2.483502G	66.85	74.00	-7.15	31.53	3	V	189	2.93	-
2437MHz	Pass	AV	4.874G	47.93	54.00	-6.07	2.55	3	H	181	2.83	-
2437MHz	Pass	PK	4.874G	58.06	74.00	-15.94	2.55	3	H	181	2.83	-
2437MHz	Pass	AV	4.874G	50.35	54.00	-3.65	2.55	3	V	340	3.69	-
2437MHz	Pass	PK	4.874G	60.62	74.00	-13.38	2.55	3	V	340	3.69	-
2462MHz	Pass	AV	2.4642G	100.61	Inf	-Inf	31.45	3	H	340	3.69	-
2462MHz	Pass	AV	2.483502G	53.57	54.00	-0.43	31.53	3	H	340	3.69	-
2462MHz	Pass	PK	2.4596G	108.78	Inf	-Inf	31.44	3	H	340	3.69	-
2462MHz	Pass	PK	2.483502G	66.78	74.00	-7.22	31.53	3	H	340	3.69	-
2462MHz	Pass	AV	2.4628G	94.91	Inf	-Inf	31.45	3	V	182	1.50	-
2462MHz	Pass	AV	2.483502G	48.60	54.00	-5.40	31.53	3	V	182	1.50	-
2462MHz	Pass	PK	2.4628G	102.93	Inf	-Inf	31.45	3	V	182	1.50	-
2462MHz	Pass	PK	2.4836G	59.04	74.00	-14.96	31.53	3	V	182	1.50	-
2462MHz	Pass	AV	4.924G	36.50	54.00	-17.50	2.63	3	H	171	3.04	-
2462MHz	Pass	PK	4.924G	50.85	74.00	-23.15	2.63	3	H	171	3.04	-
2462MHz	Pass	AV	4.924G	41.63	54.00	-12.37	2.63	3	V	15	3.69	-
2462MHz	Pass	PK	4.924G	55.41	74.00	-18.59	2.63	3	V	15	3.69	-
802.11n HT20_Nss1,(MCS0)_2TX	-	-	-	-	-	-	-	-	-	-	-	-
2412MHz	Pass	AV	2.39G	53.18	54.00	-0.82	31.17	3	H	296	3.64	-
2412MHz	Pass	AV	2.4104G	98.11	Inf	-Inf	31.25	3	H	296	3.64	-
2412MHz	Pass	PK	2.3898G	64.79	74.00	-9.21	31.17	3	H	296	3.64	-
2412MHz	Pass	PK	2.4108G	106.66	Inf	-Inf	31.25	3	H	296	3.64	-
2412MHz	Pass	AV	2.39G	50.16	54.00	-3.84	31.17	3	V	207	1.93	-
2412MHz	Pass	AV	2.4108G	93.05	Inf	-Inf	31.25	3	V	207	1.93	-
2412MHz	Pass	PK	2.39G	61.29	74.00	-12.71	31.17	3	V	207	1.93	-
2412MHz	Pass	PK	2.41G	101.89	Inf	-Inf	31.25	3	V	207	1.93	-
2412MHz	Pass	AV	4.824G	37.37	54.00	-16.63	2.48	3	H	179	2.95	-
2412MHz	Pass	PK	4.824G	51.74	74.00	-22.26	2.48	3	H	179	2.95	-
2412MHz	Pass	AV	4.824G	42.35	54.00	-11.65	2.48	3	V	342	3.66	-
2412MHz	Pass	PK	4.824G	57.71	74.00	-16.29	2.48	3	V	342	3.66	-
2437MHz	Pass	AV	2.389998G	52.06	54.00	-1.94	31.17	3	H	298	3.53	-
2437MHz	Pass	AV	2.4362G	104.89	Inf	-Inf	31.35	3	H	298	3.53	-
2437MHz	Pass	AV	2.483502G	50.91	54.00	-3.09	31.53	3	H	298	3.53	-



RSE TX above 1GHz Result

Appendix F.2

Mode	Result	Type	Freq (Hz)	Level (dBuV/m)	Limit (dBuV/m)	Margin (dB)	Factor (dB)	Dist (m)	Pol. (H/V)	Azimuth (°)	Height (m)	Comments
2437MHz	Pass	PK	2.3838G	62.83	74.00	-11.17	31.15	3	H	298	3.53	-
2437MHz	Pass	PK	2.4354G	112.27	Inf	-Inf	31.34	3	H	298	3.53	-
2437MHz	Pass	PK	2.4862G	60.15	74.00	-13.85	31.54	3	H	298	3.53	-
2437MHz	Pass	AV	2.389998G	51.45	54.00	-2.55	31.17	3	V	196	2.94	-
2437MHz	Pass	AV	2.4362G	103.54	Inf	-Inf	31.35	3	V	196	2.94	-
2437MHz	Pass	AV	2.483502G	50.33	54.00	-3.67	31.53	3	V	196	2.94	-
2437MHz	Pass	PK	2.3854G	64.16	74.00	-9.84	31.15	3	V	196	2.94	-
2437MHz	Pass	PK	2.4378G	112.48	Inf	-Inf	31.35	3	V	196	2.94	-
2437MHz	Pass	PK	2.4858G	62.91	74.00	-11.09	31.54	3	V	196	2.94	-
2437MHz	Pass	AV	4.874G	44.71	54.00	-9.29	2.55	3	H	174	3.11	-
2437MHz	Pass	PK	4.874G	58.25	74.00	-15.75	2.55	3	H	174	3.11	-
2437MHz	Pass	AV	4.874G	45.76	54.00	-8.24	2.55	3	V	208	1.13	-
2437MHz	Pass	PK	4.874G	57.04	74.00	-16.96	2.55	3	V	208	1.13	-
2462MHz	Pass	AV	2.461G	98.51	Inf	-Inf	31.44	3	H	306	3.41	-
2462MHz	Pass	AV	2.483502G	53.47	54.00	-0.53	31.53	3	H	306	3.41	-
2462MHz	Pass	PK	2.461G	107.51	Inf	-Inf	31.44	3	H	306	3.41	-
2462MHz	Pass	PK	2.483502G	64.54	74.00	-9.46	31.53	3	H	306	3.41	-
2462MHz	Pass	AV	2.461G	97.02	Inf	-Inf	31.44	3	V	196	2.80	-
2462MHz	Pass	AV	2.483502G	51.86	54.00	-2.14	31.53	3	V	196	2.80	-
2462MHz	Pass	PK	2.4608G	106.18	Inf	-Inf	31.44	3	V	196	2.80	-
2462MHz	Pass	PK	2.483502G	63.13	74.00	-10.87	31.53	3	V	196	2.80	-
2462MHz	Pass	AV	4.924G	36.74	54.00	-17.26	2.63	3	H	188	3.64	-
2462MHz	Pass	PK	4.924G	50.91	74.00	-23.09	2.63	3	H	188	3.64	-
2462MHz	Pass	AV	4.924G	42.69	54.00	-11.31	2.63	3	V	18	3.69	-
2462MHz	Pass	PK	4.924G	57.71	74.00	-16.29	2.63	3	V	18	3.69	-
802.11n HT40_Nss1,(MCS0)_2TX	-	-	-	-	-	-	-	-	-	-	-	-
2422MHz	Pass	AV	2.39G	52.64	54.00	-1.36	31.17	3	H	289	3.58	-
2422MHz	Pass	AV	2.42G	91.25	Inf	-Inf	31.29	3	H	289	3.58	-
2422MHz	Pass	AV	2.494G	47.46	54.00	-6.54	31.57	3	H	289	3.58	-
2422MHz	Pass	PK	2.3852G	63.43	74.00	-10.57	31.15	3	H	289	3.58	-
2422MHz	Pass	PK	2.4204G	98.89	Inf	-Inf	31.29	3	H	289	3.58	-
2422MHz	Pass	PK	2.4864G	57.61	74.00	-16.39	31.54	3	H	289	3.58	-
2422MHz	Pass	AV	2.39G	52.75	54.00	-1.25	31.17	3	V	182	2.07	-
2422MHz	Pass	AV	2.4132G	89.83	Inf	-Inf	31.26	3	V	182	2.07	-
2422MHz	Pass	AV	2.4936G	47.55	54.00	-6.45	31.57	3	V	182	2.07	-
2422MHz	Pass	PK	2.39G	63.62	74.00	-10.38	31.17	3	V	182	2.07	-
2422MHz	Pass	PK	2.4124G	97.89	Inf	-Inf	31.26	3	V	182	2.07	-
2422MHz	Pass	PK	2.4932G	58.68	74.00	-15.32	31.56	3	V	182	2.07	-
2422MHz	Pass	AV	4.844G	32.90	54.00	-21.10	2.51	3	H	128	3.69	-
2422MHz	Pass	PK	4.844G	46.05	74.00	-27.95	2.51	3	H	128	3.69	-
2422MHz	Pass	AV	4.844G	35.88	54.00	-18.12	2.51	3	V	342	3.63	-
2422MHz	Pass	PK	4.844G	49.35	74.00	-24.65	2.51	3	V	342	3.63	-
2437MHz	Pass	AV	2.389998G	53.31	54.00	-0.69	31.17	3	H	17	3.66	-
2437MHz	Pass	AV	2.4446G	97.70	Inf	-Inf	31.38	3	H	17	3.66	-
2437MHz	Pass	AV	2.483502G	53.61	54.00	-0.39	31.53	3	H	17	3.66	-
2437MHz	Pass	AV	4.874G	42.26	54.00	-11.74	2.55	3	H	176	3.24	-
2437MHz	Pass	PK	2.3894G	64.99	74.00	-9.01	31.17	3	H	17	3.66	-
2437MHz	Pass	PK	2.4442G	105.94	Inf	-Inf	31.38	3	H	17	3.66	-
2437MHz	Pass	PK	2.4846G	65.66	74.00	-8.34	31.53	3	H	17	3.66	-



RSE TX above 1GHz Result

Appendix F.2

Mode	Result	Type	Freq (Hz)	Level (dBuV/m)	Limit (dBuV/m)	Margin (dB)	Factor (dB)	Dist (m)	Pol. (H/V)	Azimuth (°)	Height (m)	Comments
2437MHz	Pass	PK	4.874G	53.97	74.00	-20.03	2.55	3	H	176	3.24	-
2437MHz	Pass	AV	2.389998G	52.92	54.00	-1.08	31.17	3	V	174	3.30	-
2437MHz	Pass	AV	2.4406G	98.18	Inf	-Inf	31.36	3	V	174	3.30	-
2437MHz	Pass	AV	2.483502G	51.99	54.00	-2.01	31.53	3	V	174	3.30	-
2437MHz	Pass	AV	4.874G	42.09	54.00	-11.91	2.55	3	V	339	3.59	-
2437MHz	Pass	PK	2.389998G	64.05	74.00	-9.95	31.17	3	V	174	3.30	-
2437MHz	Pass	PK	2.4414G	106.80	Inf	-Inf	31.37	3	V	174	3.30	-
2437MHz	Pass	PK	2.483502G	62.64	74.00	-11.36	31.53	3	V	174	3.30	-
2437MHz	Pass	PK	4.874G	55.61	74.00	-18.39	2.55	3	V	339	3.59	-
2452MHz	Pass	AV	2.3888G	46.67	54.00	-7.33	31.17	3	H	14	3.69	-
2452MHz	Pass	AV	2.4504G	94.51	Inf	-Inf	31.40	3	H	14	3.69	-
2452MHz	Pass	AV	2.4868G	53.53	54.00	-0.47	31.54	3	H	14	3.69	-
2452MHz	Pass	PK	2.3872G	58.08	74.00	-15.92	31.16	3	H	14	3.69	-
2452MHz	Pass	PK	2.45G	103.52	Inf	-Inf	31.40	3	H	14	3.69	-
2452MHz	Pass	PK	2.486G	67.28	74.00	-6.72	31.54	3	H	14	3.69	-
2452MHz	Pass	AV	2.39G	46.71	54.00	-7.29	31.17	3	V	176	3.22	-
2452MHz	Pass	AV	2.4464G	94.19	Inf	-Inf	31.39	3	V	176	3.22	-
2452MHz	Pass	AV	2.4856G	53.07	54.00	-0.93	31.54	3	V	176	3.22	-
2452MHz	Pass	PK	2.3872G	58.09	74.00	-15.91	31.16	3	V	176	3.22	-
2452MHz	Pass	PK	2.444G	103.28	Inf	-Inf	31.38	3	V	176	3.22	-
2452MHz	Pass	PK	2.4836G	64.81	74.00	-9.19	31.53	3	V	176	3.22	-
2452MHz	Pass	AV	4.904G	34.00	54.00	-20.00	2.60	3	H	170	3.66	-
2452MHz	Pass	PK	4.904G	47.74	74.00	-26.26	2.60	3	H	170	3.66	-
2452MHz	Pass	AV	4.904G	35.46	54.00	-18.54	2.60	3	V	185	2.96	-
2452MHz	Pass	PK	4.904G	49.09	74.00	-24.91	2.60	3	V	185	2.96	-

802.11b_(1Mbps)_2TX

2412MHz_TX

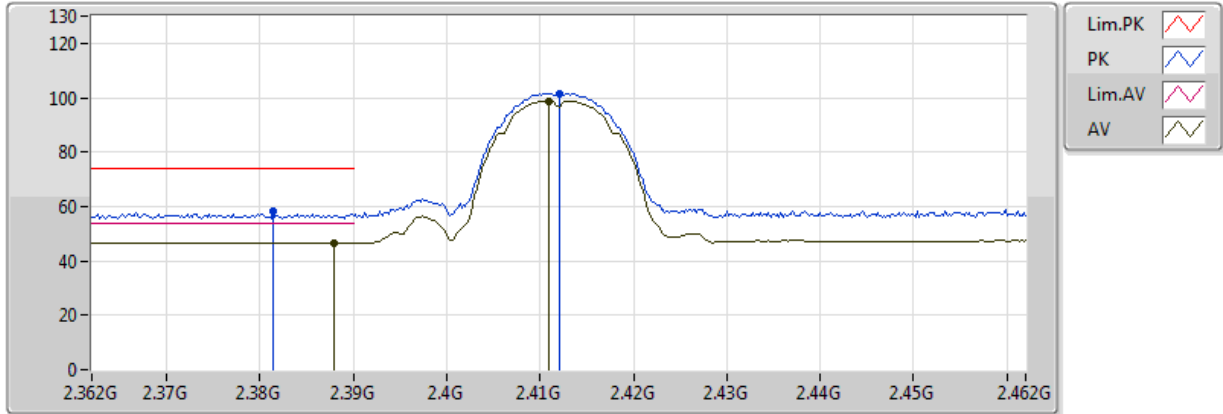

EUT = Z axis

Type	Freq(Hz)	Level(dBuV/m)	Limit(dBuV/m)	Margin(dB)	Factor(dB)	Dist(m)	Pol.(H/V)	Azimuth(°)	Height(m)	Comments
AV	2.388G	46.76	54.00	-7.24	31.16	3	V	35	3.69	-
AV	2.411G	98.90	Inf	-Inf	31.25	3	V	35	3.69	-
PK	2.3814G	58.18	74.00	-15.82	31.14	3	V	35	3.69	-
PK	2.412G	101.70	Inf	-Inf	31.26	3	V	35	3.69	-

802.11b_(1Mbps)_2TX

2412MHz_TX

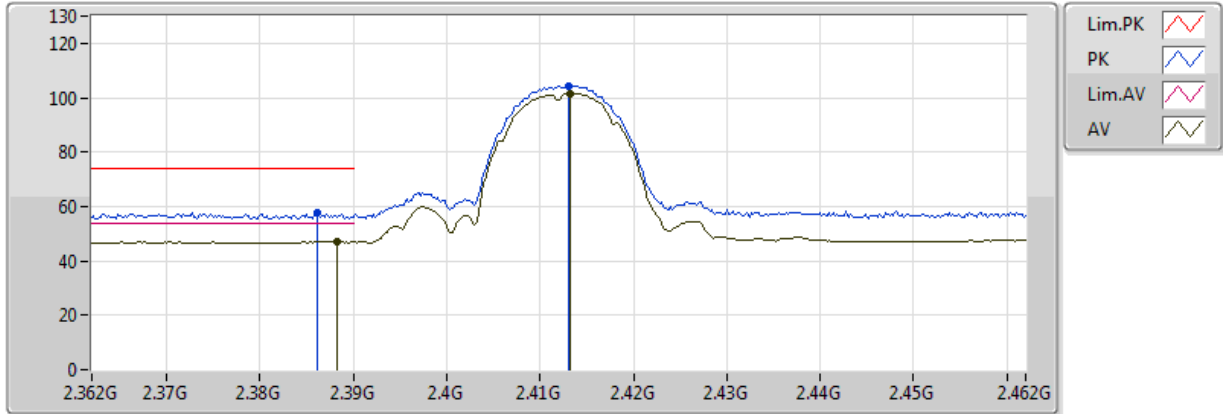

EUT = Z axis

Type	Freq(Hz)	Level(dBuV/m)	Limit(dBuV/m)	Margin(dB)	Factor(dB)	Dist(m)	Pol.(H/V)	Azimuth(°)	Height(m)	Comments
AV	2.3882G	47.08	54.00	-6.92	31.16	3	H	94	3.56	-
AV	2.4132G	101.69	Inf	-Inf	31.26	3	H	94	3.56	-
PK	2.3862G	57.47	74.00	-16.53	31.16	3	H	94	3.56	-
PK	2.413G	104.47	Inf	-Inf	31.26	3	H	94	3.56	-

802.11b_(1Mbps)_2TX

2412MHz_TX

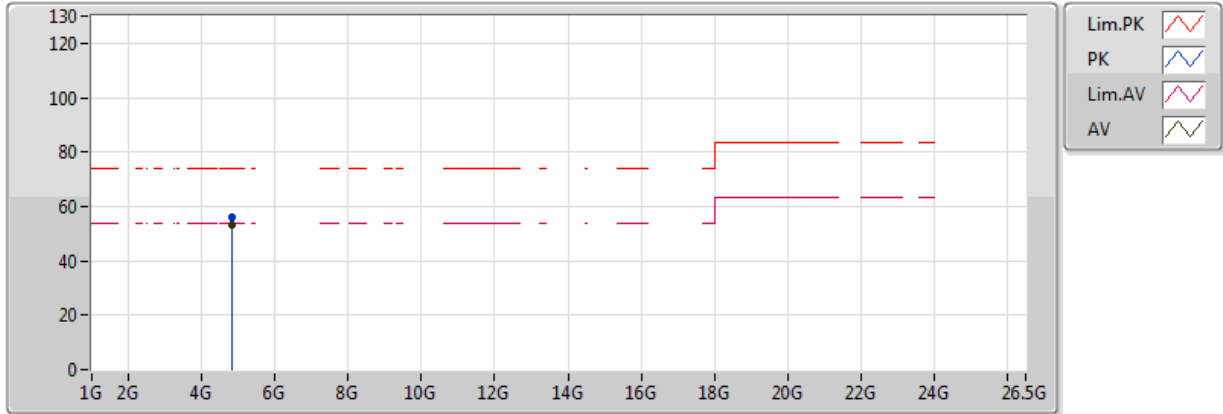

EUT = Z axis

Type	Freq(Hz)	Level(dBuV/m)	Limit(dBuV/m)	Margin(dB)	Factor(dB)	Dist(m)	Pol.(H/V)	Azimuth(°)	Height(m)	Comments
AV	4.824G	53.49	54.00	-0.51	2.48	3	V	204	1.00	-
PK	4.824G	55.97	74.00	-18.03	2.48	3	V	204	1.00	-

802.11b_(1Mbps)_2TX

2412MHz_TX

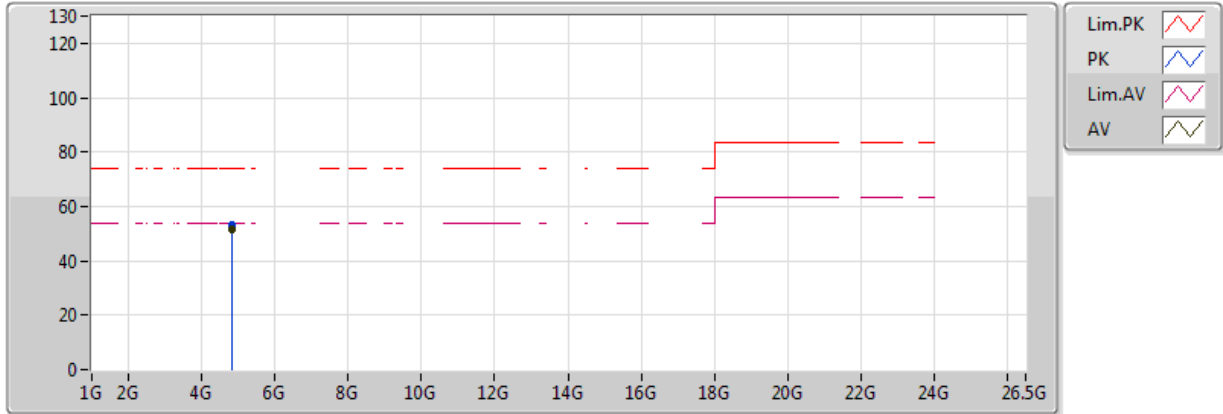

EUT = Z axis

Type	Freq(Hz)	Level(dBuV/m)	Limit(dBuV/m)	Margin(dB)	Factor(dB)	Dist(m)	Pol.(H/V)	Azimuth(°)	Height(m)	Comments
AV	4.824G	51.60	54.00	-2.40	2.48	3	H	178	3.61	-
PK	4.824G	53.11	74.00	-20.89	2.48	3	H	178	3.61	-

802.11b_(1Mbps)_2TX

2437MHz_TX

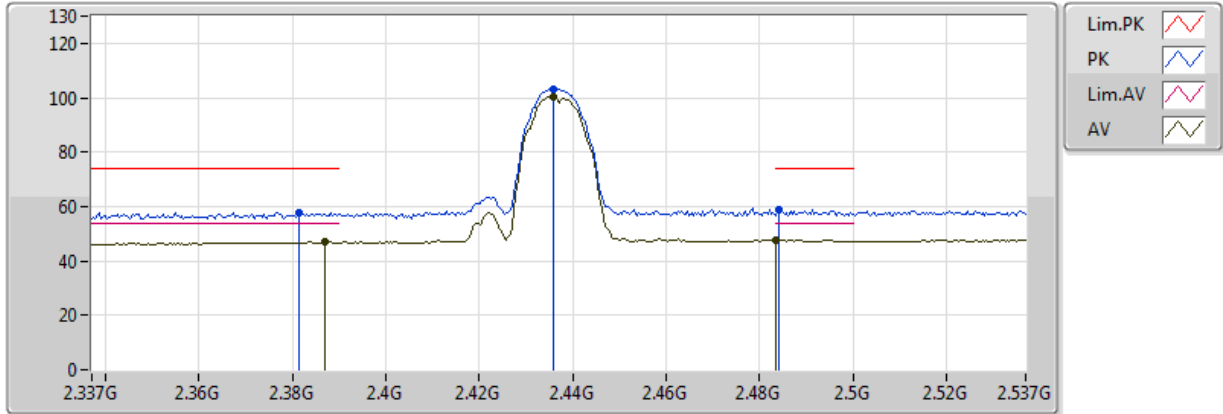

EUT = Z axis

Type	Freq(Hz)	Level(dBuV/m)	Limit(dBuV/m)	Margin(dB)	Factor(dB)	Dist(m)	Pol.(H/V)	Azimuth(°)	Height(m)	Comments
AV	2.387G	46.90	54.00	-7.10	31.16	3	V	4	3.69	-
AV	2.4358G	100.46	Inf	-Inf	31.35	3	V	4	3.69	-
AV	2.483502G	47.52	54.00	-6.48	31.53	3	V	4	3.69	-
PK	2.3814G	57.97	74.00	-16.03	31.14	3	V	4	3.69	-
PK	2.4358G	103.26	Inf	-Inf	31.35	3	V	4	3.69	-
PK	2.4842G	58.69	74.00	-15.31	31.53	3	V	4	3.69	-

802.11b_(1Mbps)_2TX

2437MHz_TX

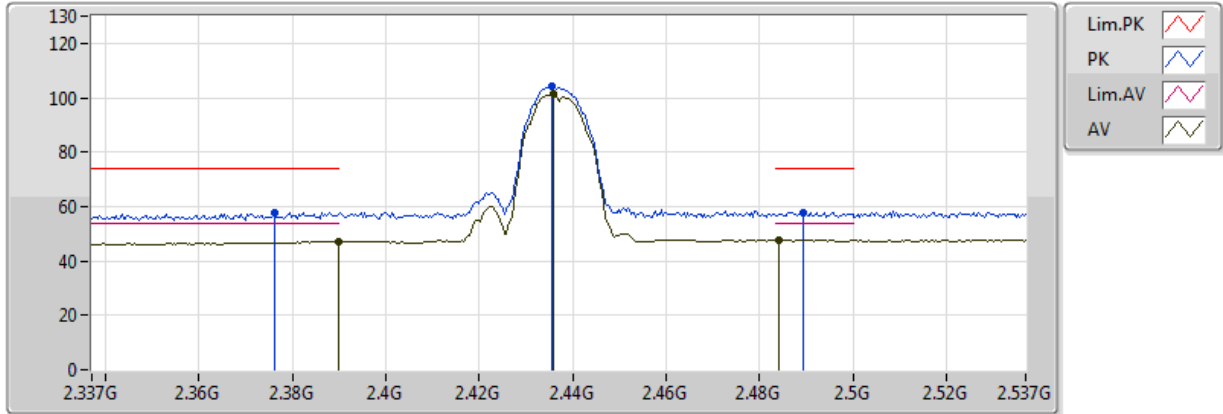

EUT = Z axis

Type	Freq(Hz)	Level(dBuV/m)	Limit(dBuV/m)	Margin(dB)	Factor(dB)	Dist(m)	Pol.(H/V)	Azimuth(°)	Height(m)	Comments
AV	2.389998G	47.18	54.00	-6.82	31.17	3	H	131	3.53	-
AV	2.4358G	101.18	Inf	-Inf	31.35	3	H	131	3.53	-
AV	2.4842G	47.53	54.00	-6.47	31.53	3	H	131	3.53	-
PK	2.3762G	57.91	74.00	-16.09	31.12	3	H	131	3.53	-
PK	2.4354G	103.95	Inf	-Inf	31.34	3	H	131	3.53	-
PK	2.4894G	57.80	74.00	-16.20	31.55	3	H	131	3.53	-

802.11b_(1Mbps)_2TX

2437MHz_TX

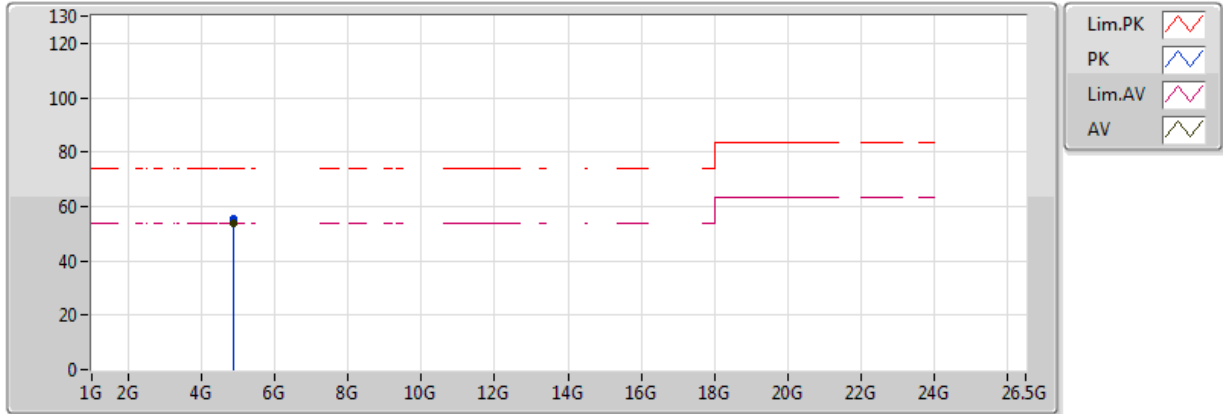

EUT = Z axis

Type	Freq(Hz)	Level(dBuV/m)	Limit(dBuV/m)	Margin(dB)	Factor(dB)	Dist(m)	Pol.(H/V)	Azimuth(°)	Height(m)	Comments
AV	4.874G	53.86	54.00	-0.14	2.55	3	V	213	1.03	-
PK	4.874G	55.48	74.00	-18.52	2.55	3	V	213	1.03	-

802.11b_(1Mbps)_2TX

2437MHz_TX

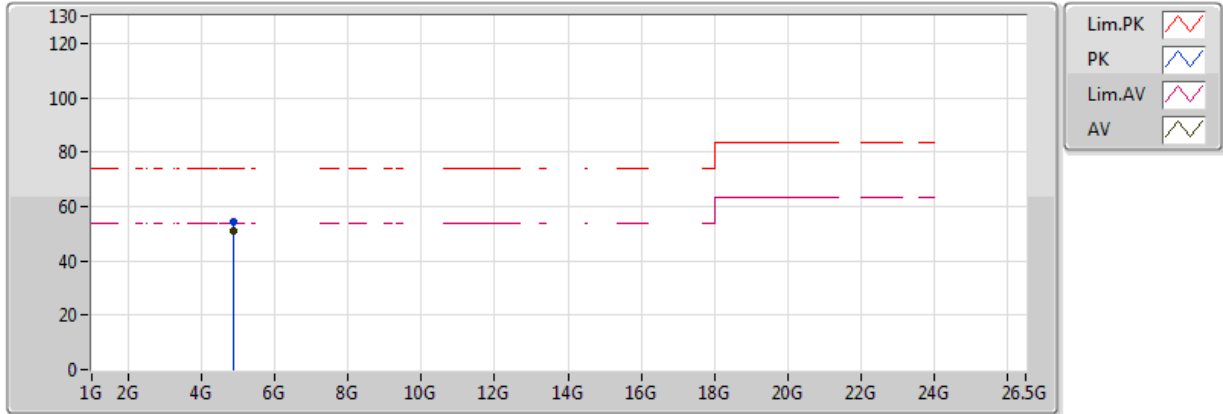

EUT = Z axis

Type	Freq(Hz)	Level(dBuV/m)	Limit(dBuV/m)	Margin(dB)	Factor(dB)	Dist(m)	Pol.(H/V)	Azimuth(°)	Height(m)	Comments
AV	4.874G	51.25	54.00	-2.75	2.55	3	H	179	3.69	-
PK	4.874G	54.38	74.00	-19.62	2.55	3	H	179	3.69	-

802.11b_(1Mbps)_2TX

2462MHz_TX

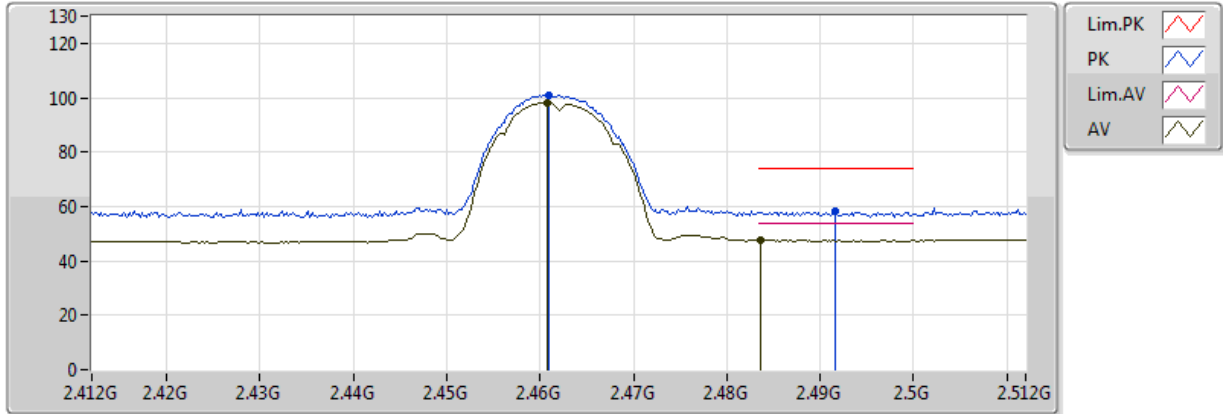

EUT = Z axis

Type	Freq(Hz)	Level(dBuV/m)	Limit(dBuV/m)	Margin(dB)	Factor(dB)	Dist(m)	Pol.(H/V)	Azimuth(°)	Height(m)	Comments
AV	2.4608G	98.26	Inf	-Inf	31.44	3	V	353	2.70	-
AV	2.4836G	47.69	54.00	-6.31	31.53	3	V	353	2.70	-
PK	2.461G	100.98	Inf	-Inf	31.44	3	V	353	2.70	-
PK	2.4916G	58.01	74.00	-15.99	31.56	3	V	353	2.70	-

802.11b_(1Mbps)_2TX

2462MHz_TX

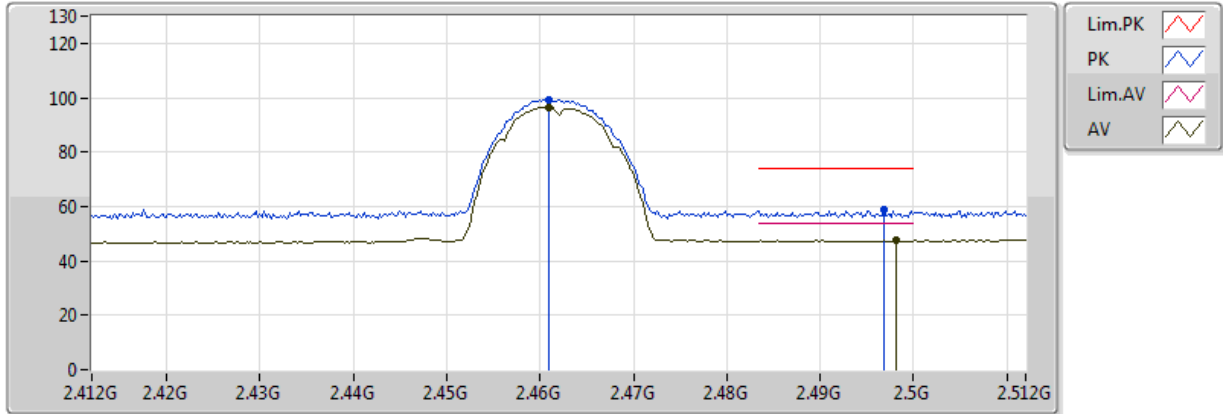

EUT = Z axis

Type	Freq(Hz)	Level(dBuV/m)	Limit(dBuV/m)	Margin(dB)	Factor(dB)	Dist(m)	Pol.(H/V)	Azimuth(°)	Height(m)	Comments
AV	2.461G	96.55	Inf	-Inf	31.44	3	H	314	3.03	-
AV	2.4982G	47.41	54.00	-6.59	31.58	3	H	314	3.03	-
PK	2.461G	99.32	Inf	-Inf	31.44	3	H	314	3.03	-
PK	2.4968G	58.63	74.00	-15.37	31.58	3	H	314	3.03	-

802.11b_(1Mbps)_2TX

2462MHz_TX

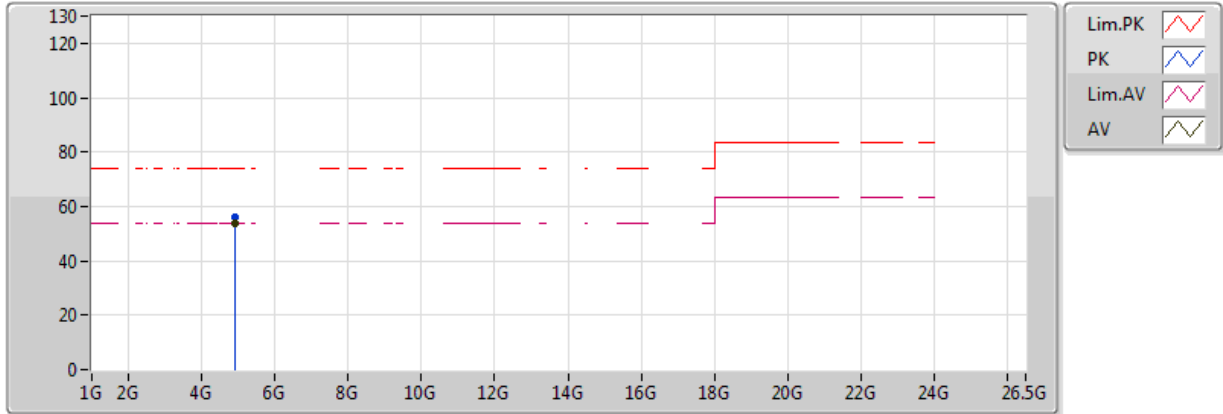

EUT = Z axis

Type	Freq(Hz)	Level(dBuV/m)	Limit(dBuV/m)	Margin(dB)	Factor(dB)	Dist(m)	Pol.(H/V)	Azimuth(°)	Height(m)	Comments
AV	4.924G	53.61	54.00	-0.39	2.63	3	V	23	3.69	-
PK	4.924G	55.84	74.00	-18.16	2.63	3	V	23	3.69	-

802.11b_(1Mbps)_2TX

2462MHz_TX

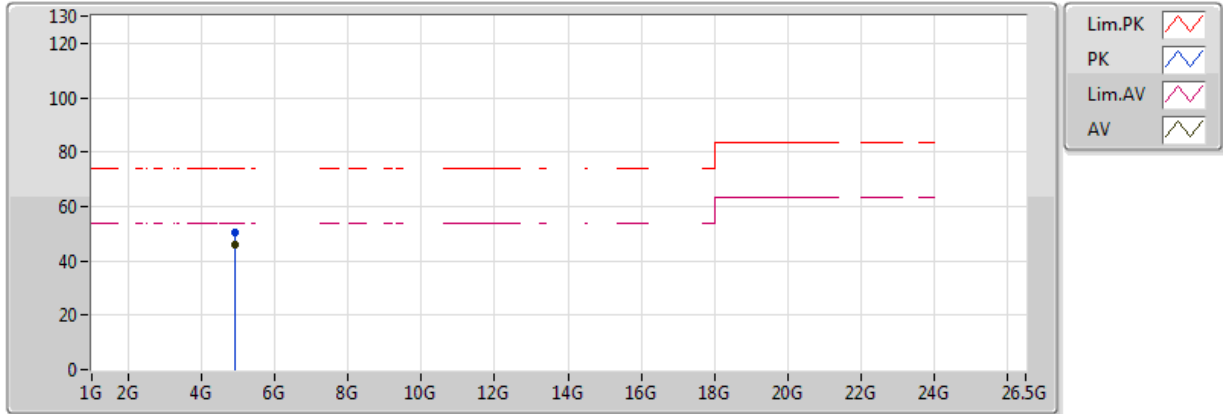

EUT = Z axis

Type	Freq(Hz)	Level(dBuV/m)	Limit(dBuV/m)	Margin(dB)	Factor(dB)	Dist(m)	Pol.(H/V)	Azimuth(°)	Height(m)	Comments
AV	4.924G	45.77	54.00	-8.23	2.63	3	H	175	2.81	-
PK	4.924G	50.52	74.00	-23.48	2.63	3	H	175	2.81	-

802.11g_(6Mbps)_2TX

2412MHz_TX

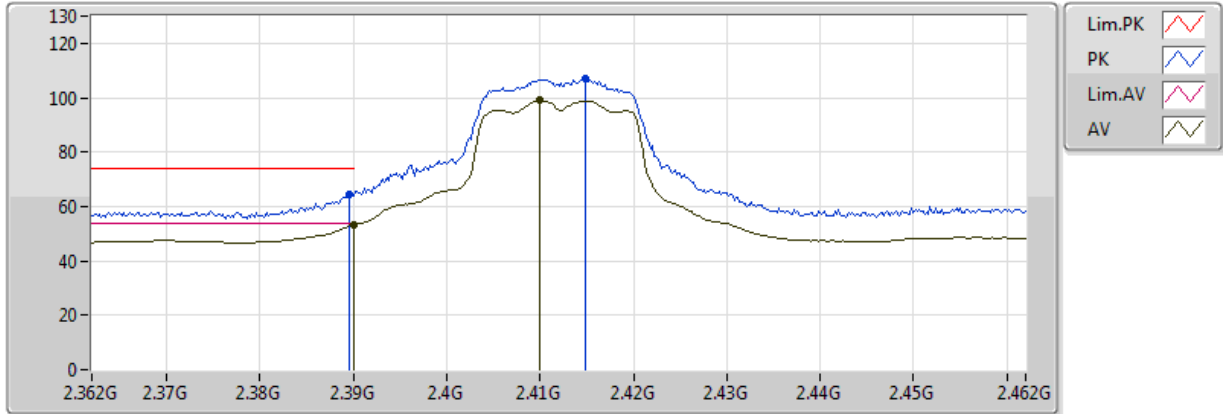

EUT = Z axis

Type	Freq(Hz)	Level(dBuV/m)	Limit(dBuV/m)	Margin(dB)	Factor(dB)	Dist(m)	Pol.(H/V)	Azimuth(°)	Height(m)	Comments
AV	2.39G	53.36	54.00	-0.64	31.17	3	V	29	3.69	-
AV	2.41G	98.94	Inf	-Inf	31.25	3	V	29	3.69	-
PK	2.3896G	64.54	74.00	-9.46	31.17	3	V	29	3.69	-
PK	2.4148G	107.24	Inf	-Inf	31.27	3	V	29	3.69	-

802.11g_(6Mbps)_2TX

2412MHz_TX

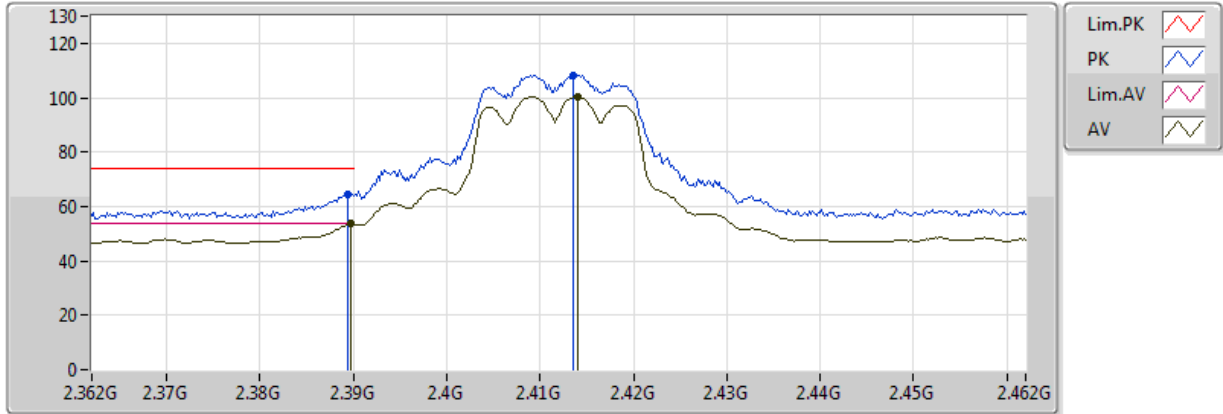

EUT = Z axis

Type	Freq(Hz)	Level(dBuV/m)	Limit(dBuV/m)	Margin(dB)	Factor(dB)	Dist(m)	Pol.(H/V)	Azimuth(°)	Height(m)	Comments
AV	2.3898G	53.57	54.00	-0.43	31.17	3	H	95	3.56	-
AV	2.414G	100.37	Inf	-Inf	31.26	3	H	95	3.56	-
PK	2.3894G	64.48	74.00	-9.52	31.17	3	H	95	3.56	-
PK	2.4136G	108.02	Inf	-Inf	31.26	3	H	95	3.56	-

802.11g_(6Mbps)_2TX

2412MHz_TX

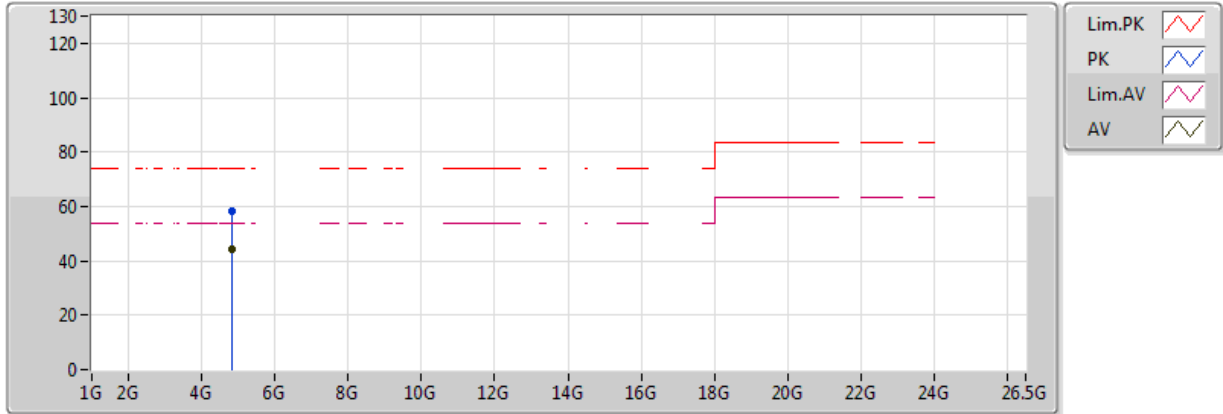

EUT = Z axis

Type	Freq(Hz)	Level(dBuV/m)	Limit(dBuV/m)	Margin(dB)	Factor(dB)	Dist(m)	Pol.(H/V)	Azimuth(°)	Height(m)	Comments
AV	4.824G	44.52	54.00	-9.48	2.48	3	V	337	3.69	-
PK	4.824G	58.48	74.00	-15.52	2.48	3	V	337	3.69	-

802.11g_(6Mbps)_2TX

2412MHz_TX

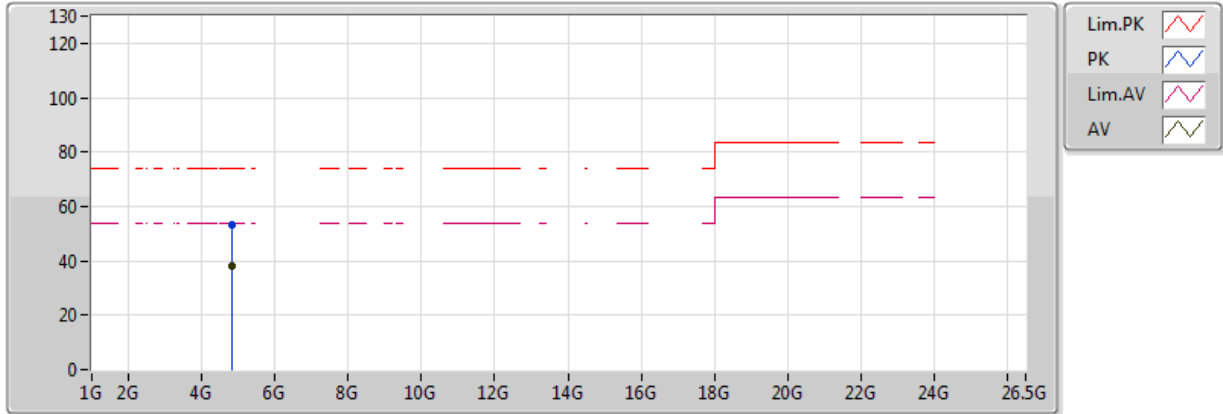

EUT = Z axis

Type	Freq(Hz)	Level(dBuV/m)	Limit(dBuV/m)	Margin(dB)	Factor(dB)	Dist(m)	Pol.(H/V)	Azimuth(°)	Height(m)	Comments
AV	4.824G	38.29	54.00	-15.71	2.48	3	H	171	3.69	-
PK	4.824G	53.33	74.00	-20.67	2.48	3	H	171	3.69	-

802.11g_(6Mbps)_2TX

2437MHz_TX

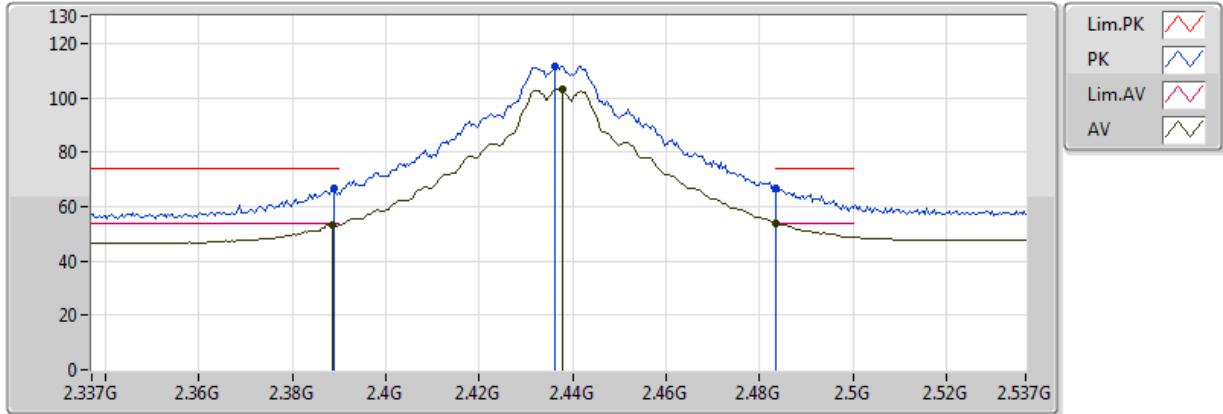

EUT = Z axis

Type	Freq(Hz)	Level(dBuV/m)	Limit(dBuV/m)	Margin(dB)	Factor(dB)	Dist(m)	Pol.(H/V)	Azimuth(°)	Height(m)	Comments
AV	2.3886G	53.12	54.00	-0.88	31.17	3	V	189	2.93	-
AV	2.4378G	103.35	Inf	-Inf	31.35	3	V	189	2.93	-
AV	2.483502G	53.59	54.00	-0.41	31.53	3	V	189	2.93	-
PK	2.389G	66.89	74.00	-7.11	31.17	3	V	189	2.93	-
PK	2.4362G	111.73	Inf	-Inf	31.35	3	V	189	2.93	-
PK	2.483502G	66.85	74.00	-7.15	31.53	3	V	189	2.93	-

802.11g_(6Mbps)_2TX

2437MHz_TX

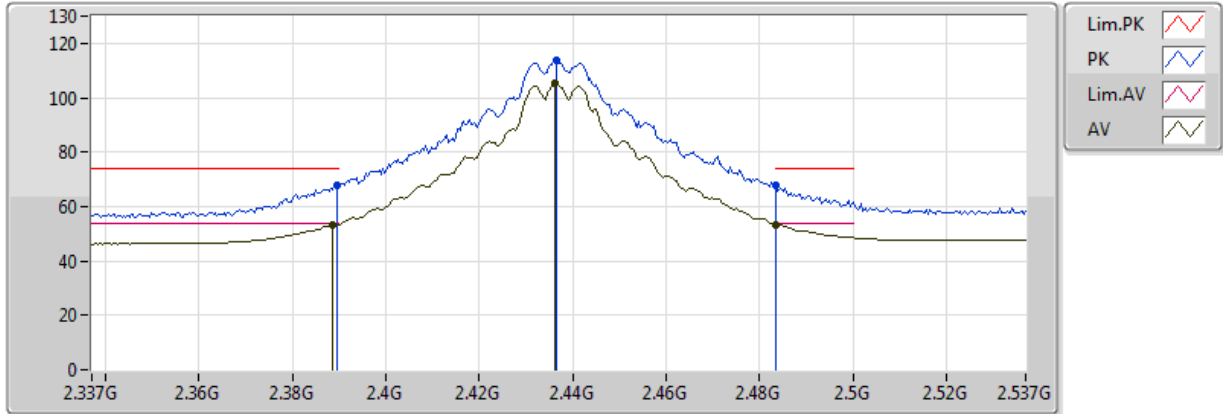

EUT = Z axis

Type	Freq(Hz)	Level(dBuV/m)	Limit(dBuV/m)	Margin(dB)	Factor(dB)	Dist(m)	Pol.(H/V)	Azimuth(°)	Height(m)	Comments
AV	2.3886G	53.38	54.00	-0.62	31.17	3	H	288	3.53	-
AV	2.4362G	105.42	Inf	-Inf	31.35	3	H	288	3.53	-
AV	2.483502G	53.12	54.00	-0.88	31.53	3	H	288	3.53	-
PK	2.3894G	67.77	74.00	-6.23	31.17	3	H	288	3.53	-
PK	2.4366G	114.03	Inf	-Inf	31.35	3	H	288	3.53	-
PK	2.483502G	67.94	74.00	-6.06	31.53	3	H	288	3.53	-

802.11g_(6Mbps)_2TX

2437MHz_TX

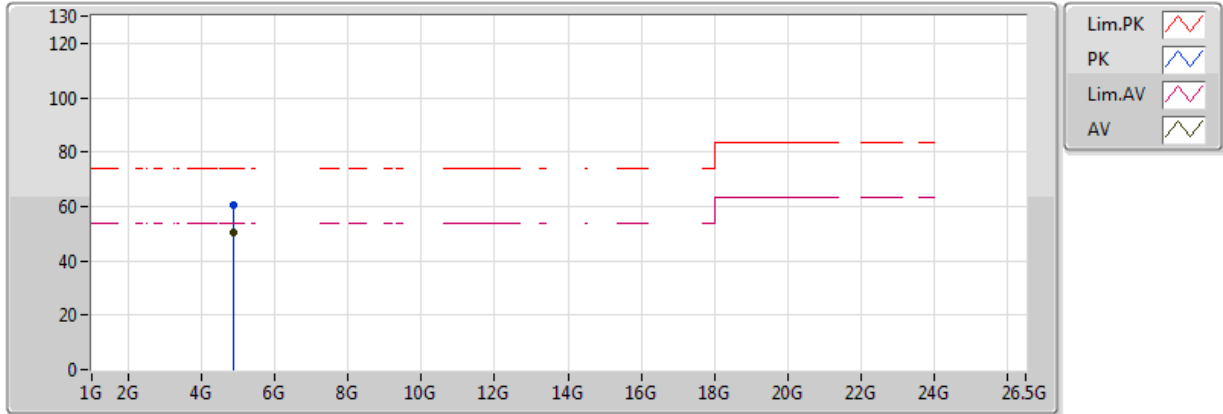

EUT = Z axis

Type	Freq(Hz)	Level(dBuV/m)	Limit(dBuV/m)	Margin(dB)	Factor(dB)	Dist(m)	Pol.(H/V)	Azimuth(°)	Height(m)	Comments
AV	4.874G	50.35	54.00	-3.65	2.55	3	V	340	3.69	-
PK	4.874G	60.62	74.00	-13.38	2.55	3	V	340	3.69	-

802.11g_(6Mbps)_2TX

2437MHz_TX

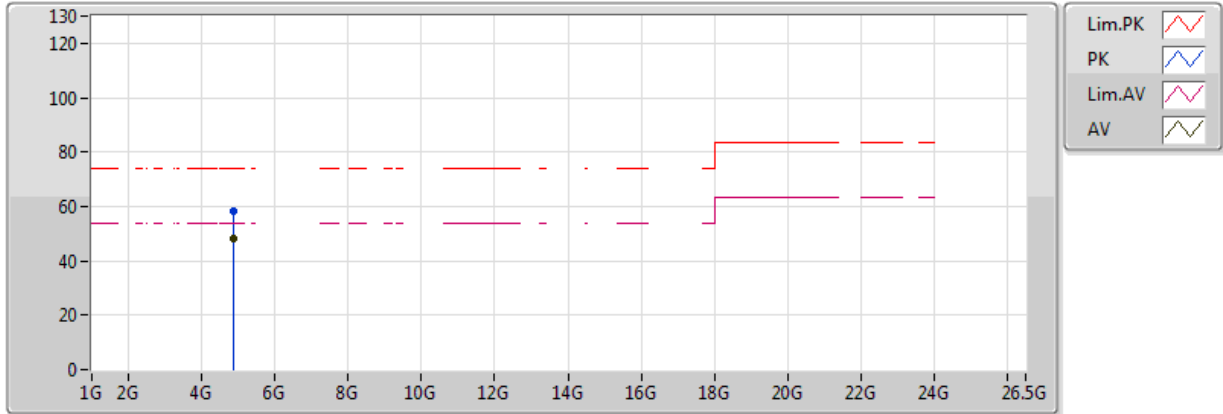

EUT = Z axis

Type	Freq(Hz)	Level(dBuV/m)	Limit(dBuV/m)	Margin(dB)	Factor(dB)	Dist(m)	Pol.(H/V)	Azimuth(°)	Height(m)	Comments
AV	4.874G	47.93	54.00	-6.07	2.55	3	H	181	2.83	-
PK	4.874G	58.06	74.00	-15.94	2.55	3	H	181	2.83	-

802.11g_(6Mbps)_2TX

2462MHz_TX

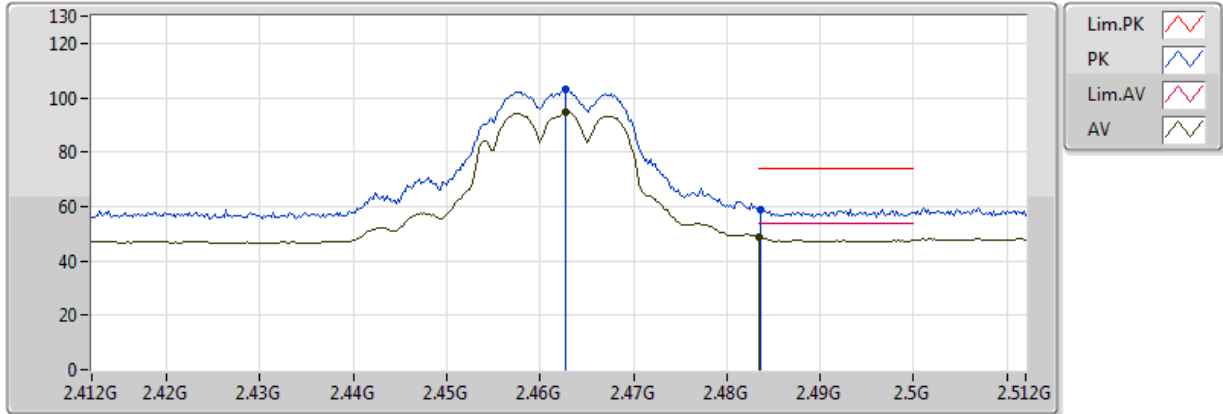

EUT = Z axis

Type	Freq(Hz)	Level(dBuV/m)	Limit(dBuV/m)	Margin(dB)	Factor(dB)	Dist(m)	Pol.(H/V)	Azimuth(°)	Height(m)	Comments
AV	2.4628G	94.91	Inf	-Inf	31.45	3	V	182	1.50	-
AV	2.483502G	48.60	54.00	-5.40	31.53	3	V	182	1.50	-
PK	2.4628G	102.93	Inf	-Inf	31.45	3	V	182	1.50	-
PK	2.4836G	59.04	74.00	-14.96	31.53	3	V	182	1.50	-

802.11g_(6Mbps)_2TX

2462MHz_TX

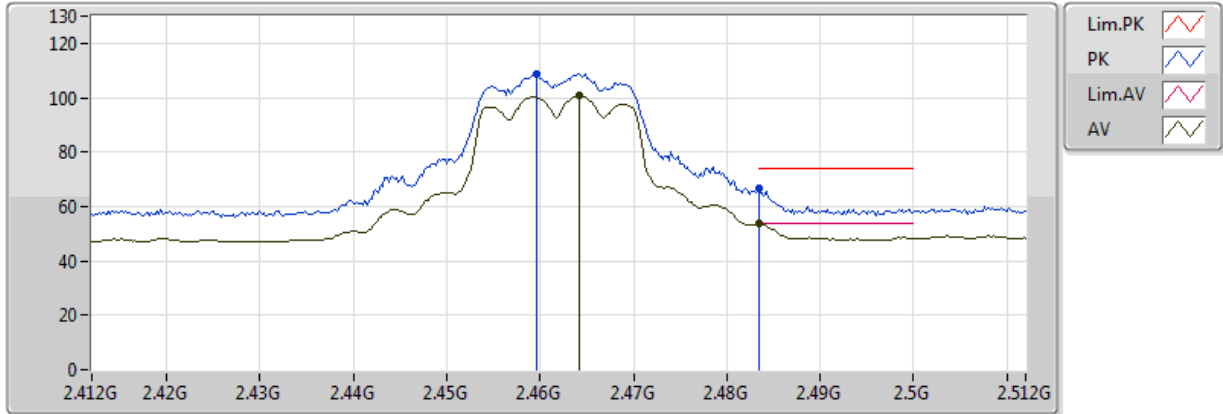

EUT = Z axis

Type	Freq(Hz)	Level(dBuV/m)	Limit(dBuV/m)	Margin(dB)	Factor(dB)	Dist(m)	Pol.(H/V)	Azimuth(°)	Height(m)	Comments
AV	2.4642G	100.61	Inf	-Inf	31.45	3	H	340	3.69	-
AV	2.483502G	53.57	54.00	-0.43	31.53	3	H	340	3.69	-
PK	2.4596G	108.78	Inf	-Inf	31.44	3	H	340	3.69	-
PK	2.483502G	66.78	74.00	-7.22	31.53	3	H	340	3.69	-

802.11g_(6Mbps)_2TX

2462MHz_TX

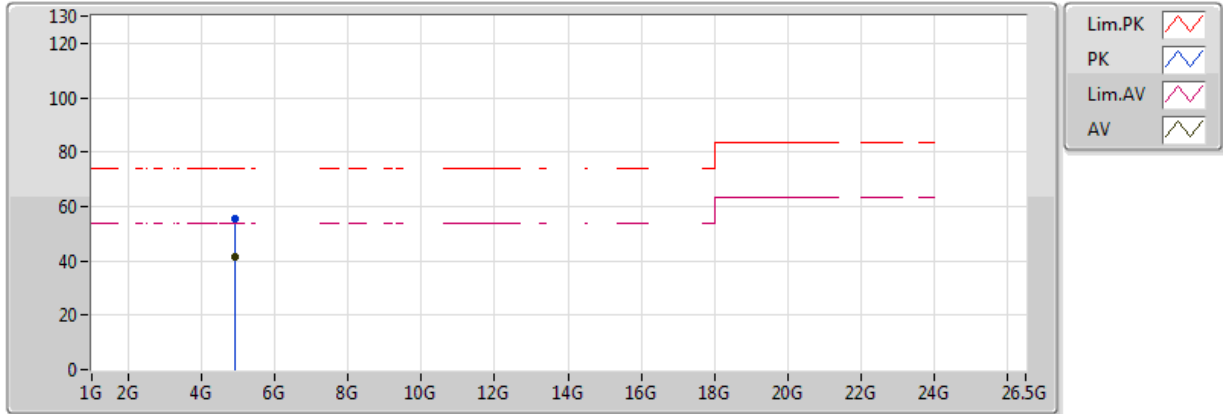

EUT = Z axis

Type	Freq(Hz)	Level(dBuV/m)	Limit(dBuV/m)	Margin(dB)	Factor(dB)	Dist(m)	Pol.(H/V)	Azimuth(°)	Height(m)	Comments
AV	4.924G	41.63	54.00	-12.37	2.63	3	V	15	3.69	-
PK	4.924G	55.41	74.00	-18.59	2.63	3	V	15	3.69	-

802.11g_(6Mbps)_2TX

2462MHz_TX

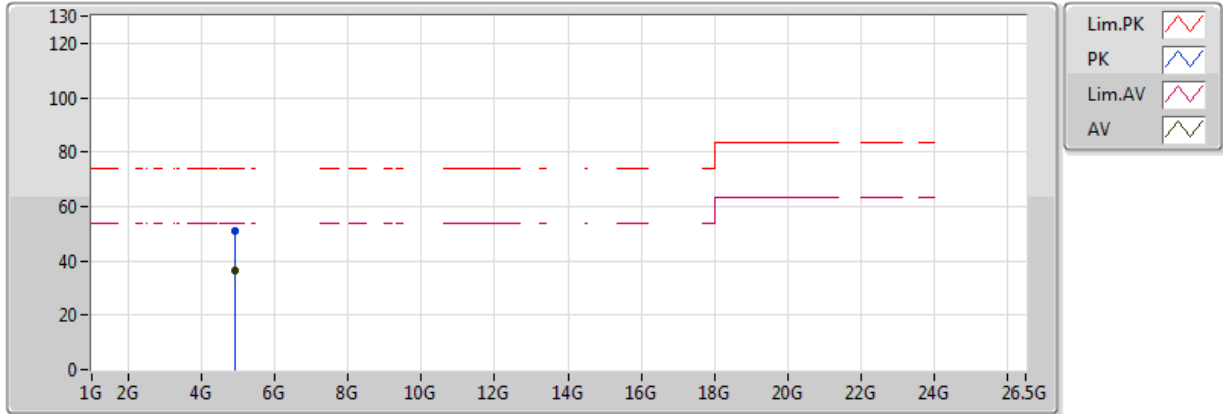

EUT = Z axis

Type	Freq(Hz)	Level(dBuV/m)	Limit(dBuV/m)	Margin(dB)	Factor(dB)	Dist(m)	Pol.(H/V)	Azimuth(°)	Height(m)	Comments
AV	4.924G	36.50	54.00	-17.50	2.63	3	H	171	3.04	-
PK	4.924G	50.85	74.00	-23.15	2.63	3	H	171	3.04	-

**802.11n HT20_Nss1,(MCS0)_2TX
2412MHz_TX**

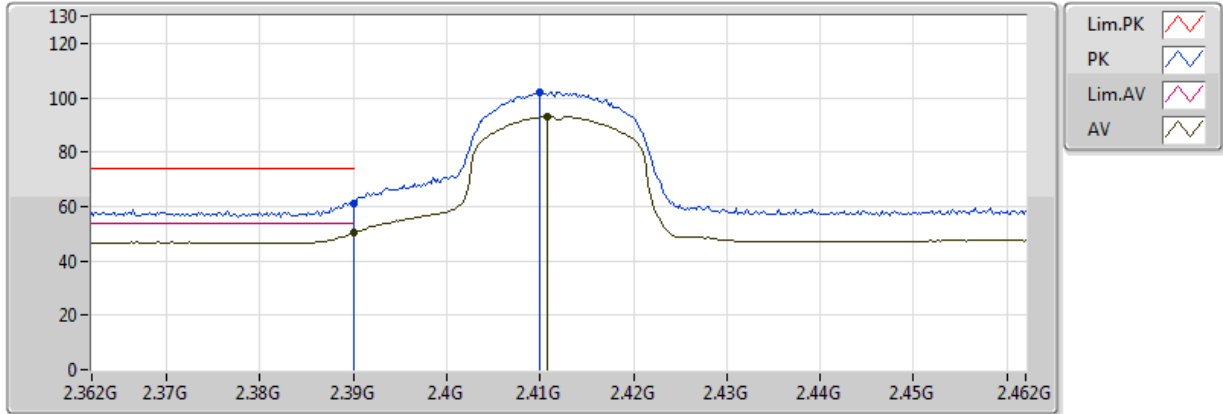

EUT = Z axis

Type	Freq(Hz)	Level(dBuV/m)	Limit(dBuV/m)	Margin(dB)	Factor(dB)	Dist(m)	Pol.(H/V)	Azimuth(°)	Height(m)	Comments
AV	2.39G	50.16	54.00	-3.84	31.17	3	V	207	1.93	-
AV	2.4108G	93.05	Inf	-Inf	31.25	3	V	207	1.93	-
PK	2.39G	61.29	74.00	-12.71	31.17	3	V	207	1.93	-
PK	2.41G	101.89	Inf	-Inf	31.25	3	V	207	1.93	-

**802.11n HT20_Nss1,(MCS0)_2TX
2412MHz_TX**

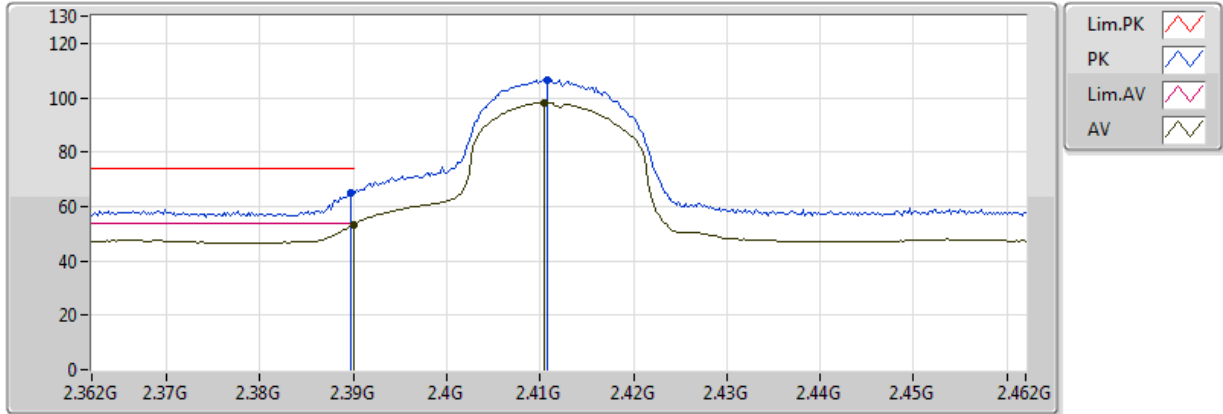

EUT = Z axis

Type	Freq(Hz)	Level(dBuV/m)	Limit(dBuV/m)	Margin(dB)	Factor(dB)	Dist(m)	Pol.(H/V)	Azimuth(°)	Height(m)	Comments
AV	2.39G	53.18	54.00	-0.82	31.17	3	H	296	3.64	-
AV	2.4104G	98.11	Inf	-Inf	31.25	3	H	296	3.64	-
PK	2.3898G	64.79	74.00	-9.21	31.17	3	H	296	3.64	-
PK	2.4108G	106.66	Inf	-Inf	31.25	3	H	296	3.64	-

**802.11n HT20_Nss1,(MCS0)_2TX
2412MHz_TX**

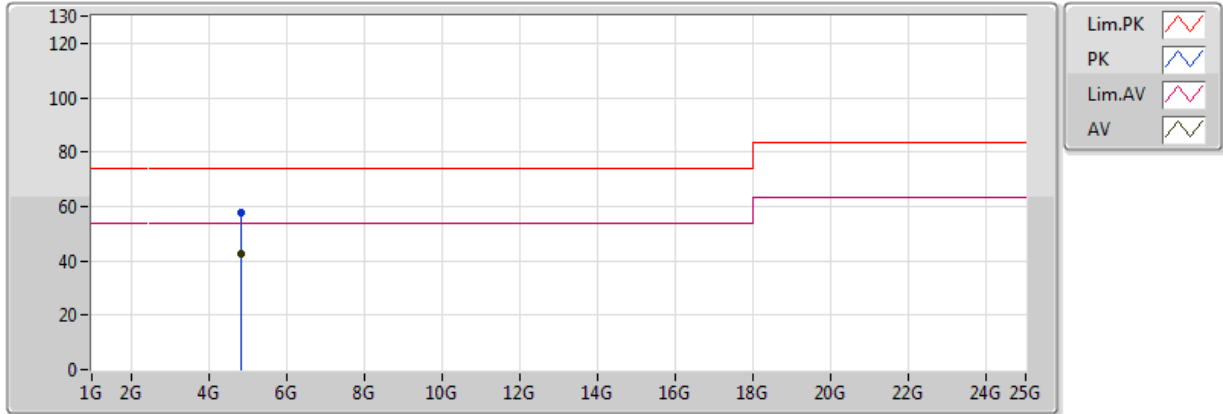

EUT = Z axis

Type	Freq(Hz)	Level(dBuV/m)	Limit(dBuV/m)	Margin(dB)	Factor(dB)	Dist(m)	Pol.(H/V)	Azimuth(°)	Height(m)	Comments
AV	4.824G	42.35	54.00	-11.65	2.48	3	V	342	3.66	-
PK	4.824G	57.71	74.00	-16.29	2.48	3	V	342	3.66	-

802.11n HT20_Nss1,(MCS0)_2TX

2412MHz_TX

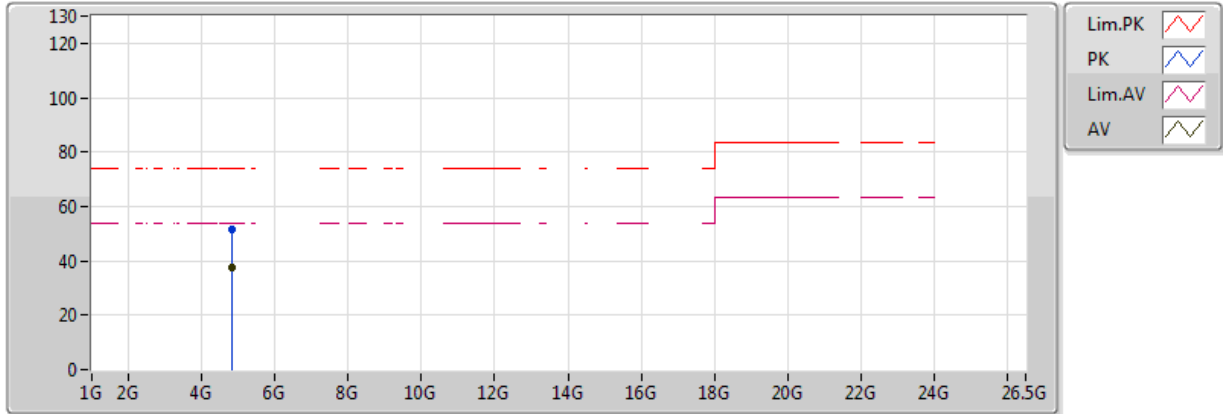

EUT = Z axis

Type	Freq(Hz)	Level(dBuV/m)	Limit(dBuV/m)	Margin(dB)	Factor(dB)	Dist(m)	Pol.(H/V)	Azimuth(°)	Height(m)	Comments
AV	4.824G	37.37	54.00	-16.63	2.48	3	H	179	2.95	-
PK	4.824G	51.74	74.00	-22.26	2.48	3	H	179	2.95	-

**802.11n HT20_Nss1,(MCS0)_2TX
2437MHz_TX**

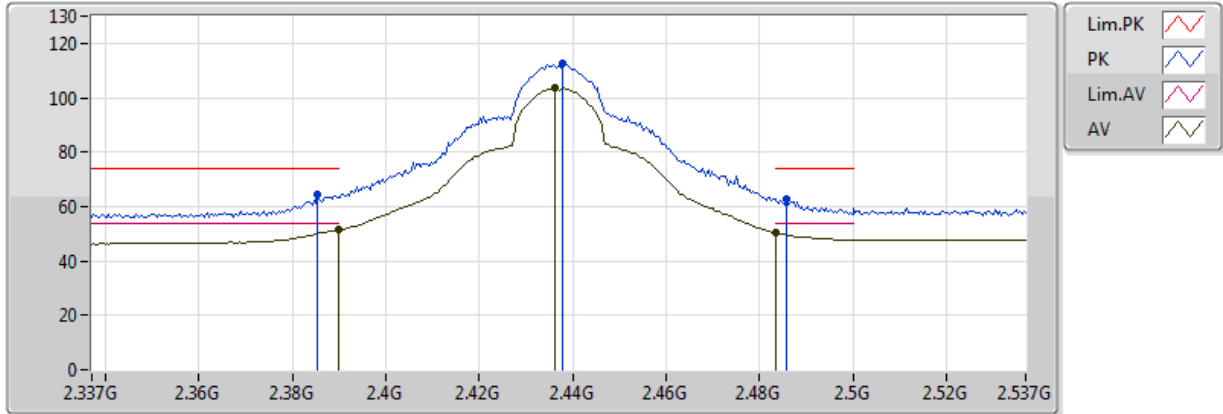

EUT = Z axis

Type	Freq(Hz)	Level(dBuV/m)	Limit(dBuV/m)	Margin(dB)	Factor(dB)	Dist(m)	Pol.(H/V)	Azimuth(°)	Height(m)	Comments
AV	2.389998G	51.45	54.00	-2.55	31.17	3	V	196	2.94	-
AV	2.4362G	103.54	Inf	-Inf	31.35	3	V	196	2.94	-
AV	2.483502G	50.33	54.00	-3.67	31.53	3	V	196	2.94	-
PK	2.3854G	64.16	74.00	-9.84	31.15	3	V	196	2.94	-
PK	2.4378G	112.48	Inf	-Inf	31.35	3	V	196	2.94	-
PK	2.4858G	62.91	74.00	-11.09	31.54	3	V	196	2.94	-

802.11n HT20_Nss1,(MCS0)_2TX

2437MHz_TX

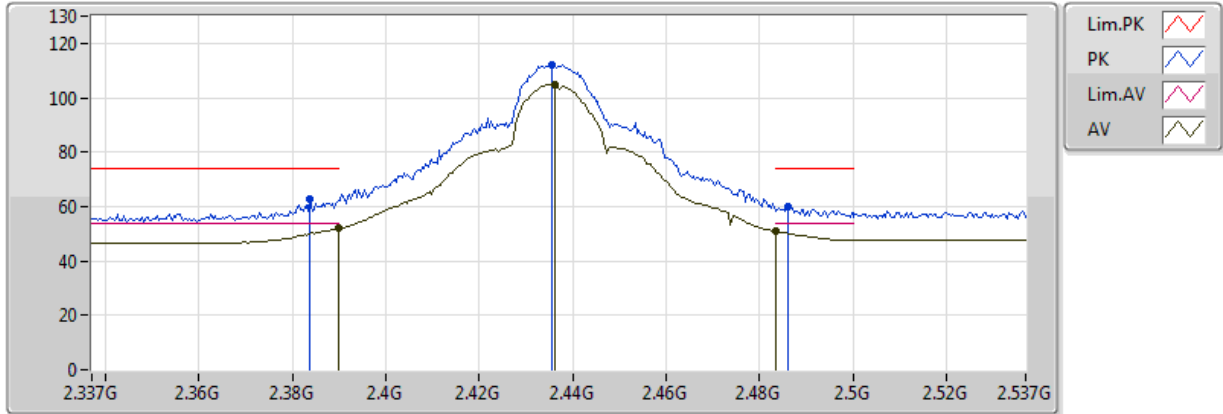

EUT = Z axis

Type	Freq(Hz)	Level(dBuV/m)	Limit(dBuV/m)	Margin(dB)	Factor(dB)	Dist(m)	Pol.(H/V)	Azimuth(°)	Height(m)	Comments
AV	2.389998G	52.06	54.00	-1.94	31.17	3	H	298	3.53	-
AV	2.4362G	104.89	Inf	-Inf	31.35	3	H	298	3.53	-
AV	2.483502G	50.91	54.00	-3.09	31.53	3	H	298	3.53	-
PK	2.3838G	62.83	74.00	-11.17	31.15	3	H	298	3.53	-
PK	2.4354G	112.27	Inf	-Inf	31.34	3	H	298	3.53	-
PK	2.4862G	60.15	74.00	-13.85	31.54	3	H	298	3.53	-

**802.11n HT20_Nss1,(MCS0)_2TX
2437MHz_TX**

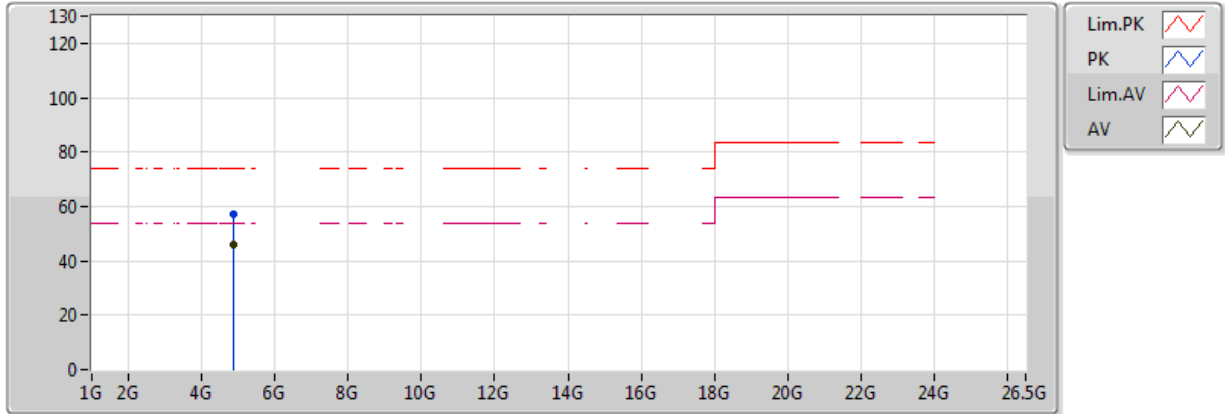

EUT = Z axis

Type	Freq(Hz)	Level(dBuV/m)	Limit(dBuV/m)	Margin(dB)	Factor(dB)	Dist(m)	Pol.(H/V)	Azimuth(°)	Height(m)	Comments
AV	4.874G	45.76	54.00	-8.24	2.55	3	V	208	1.13	-
PK	4.874G	57.04	74.00	-16.96	2.55	3	V	208	1.13	-

**802.11n HT20_Nss1,(MCS0)_2TX
2437MHz_TX**

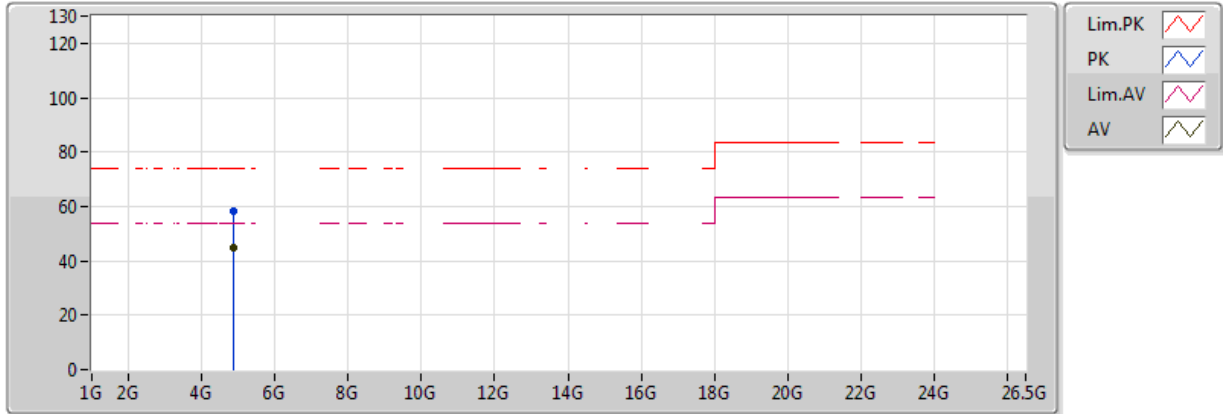

EUT = Z axis

Type	Freq(Hz)	Level(dBuV/m)	Limit(dBuV/m)	Margin(dB)	Factor(dB)	Dist(m)	Pol.(H/V)	Azimuth(°)	Height(m)	Comments
AV	4.874G	44.71	54.00	-9.29	2.55	3	H	174	3.11	-
PK	4.874G	58.25	74.00	-15.75	2.55	3	H	174	3.11	-

802.11n HT20_Nss1,(MCS0)_2TX

2462MHz_TX

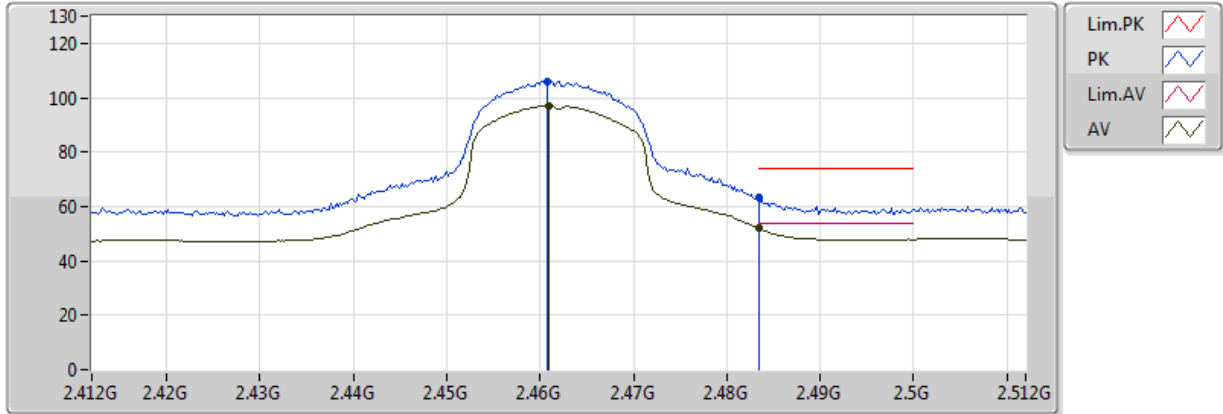

EUT = Z axis

Type	Freq(Hz)	Level(dBuV/m)	Limit(dBuV/m)	Margin(dB)	Factor(dB)	Dist(m)	Pol.(H/V)	Azimuth(°)	Height(m)	Comments
AV	2.461G	97.02	Inf	-Inf	31.44	3	V	196	2.80	-
AV	2.483502G	51.86	54.00	-2.14	31.53	3	V	196	2.80	-
PK	2.4608G	106.18	Inf	-Inf	31.44	3	V	196	2.80	-
PK	2.483502G	63.13	74.00	-10.87	31.53	3	V	196	2.80	-

802.11n HT20_Nss1,(MCS0)_2TX

2462MHz_TX

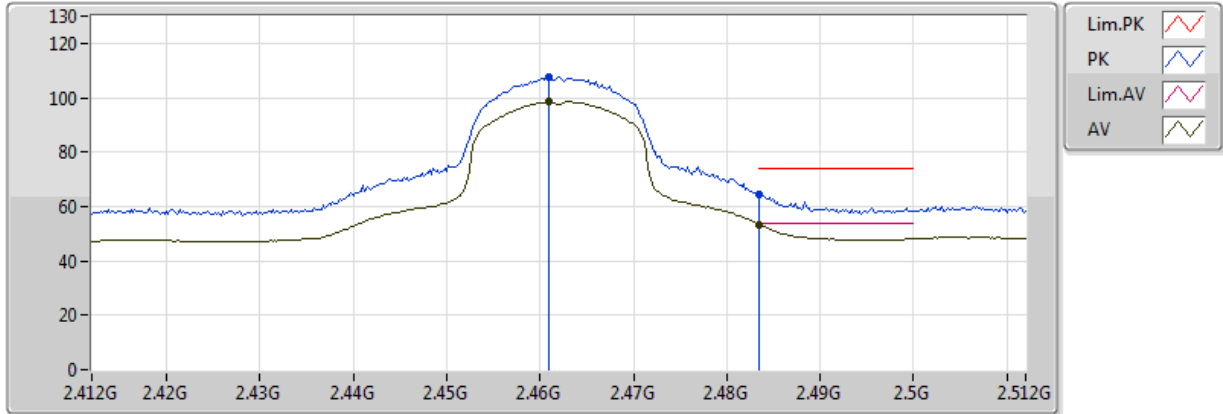

EUT = Z axis

Type	Freq(Hz)	Level(dBuV/m)	Limit(dBuV/m)	Margin(dB)	Factor(dB)	Dist(m)	Pol.(H/V)	Azimuth(°)	Height(m)	Comments
AV	2.461G	98.51	Inf	-Inf	31.44	3	H	306	3.41	-
AV	2.483502G	53.47	54.00	-0.53	31.53	3	H	306	3.41	-
PK	2.461G	107.51	Inf	-Inf	31.44	3	H	306	3.41	-
PK	2.483502G	64.54	74.00	-9.46	31.53	3	H	306	3.41	-

**802.11n HT20_Nss1,(MCS0)_2TX
2462MHz_TX**

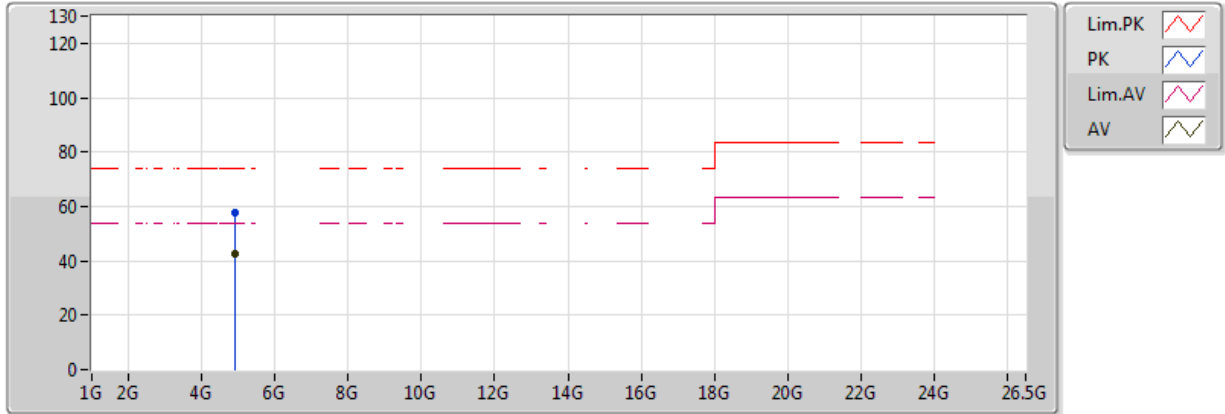

EUT = Z axis

Type	Freq(Hz)	Level(dBuV/m)	Limit(dBuV/m)	Margin(dB)	Factor(dB)	Dist(m)	Pol.(H/V)	Azimuth(°)	Height(m)	Comments
AV	4.924G	42.69	54.00	-11.31	2.63	3	V	18	3.69	-
PK	4.924G	57.71	74.00	-16.29	2.63	3	V	18	3.69	-

802.11n HT20_Nss1,(MCS0)_2TX

2462MHz_TX

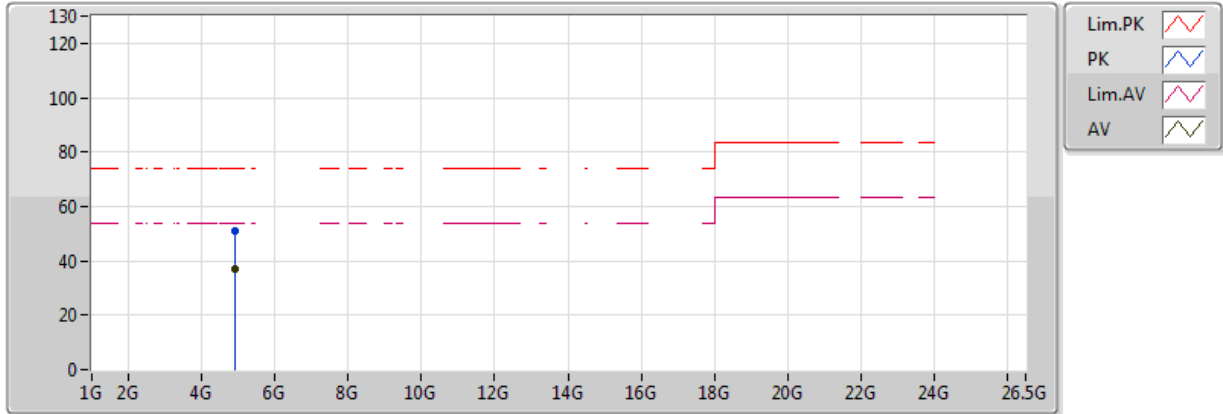

EUT = Z axis

Type	Freq(Hz)	Level(dBuV/m)	Limit(dBuV/m)	Margin(dB)	Factor(dB)	Dist(m)	Pol.(H/V)	Azimuth(°)	Height(m)	Comments
AV	4.924G	36.74	54.00	-17.26	2.63	3	H	188	3.64	-
PK	4.924G	50.91	74.00	-23.09	2.63	3	H	188	3.64	-

**802.11n HT40_Nss1,(MCS0)_2TX
2422MHz_TX**

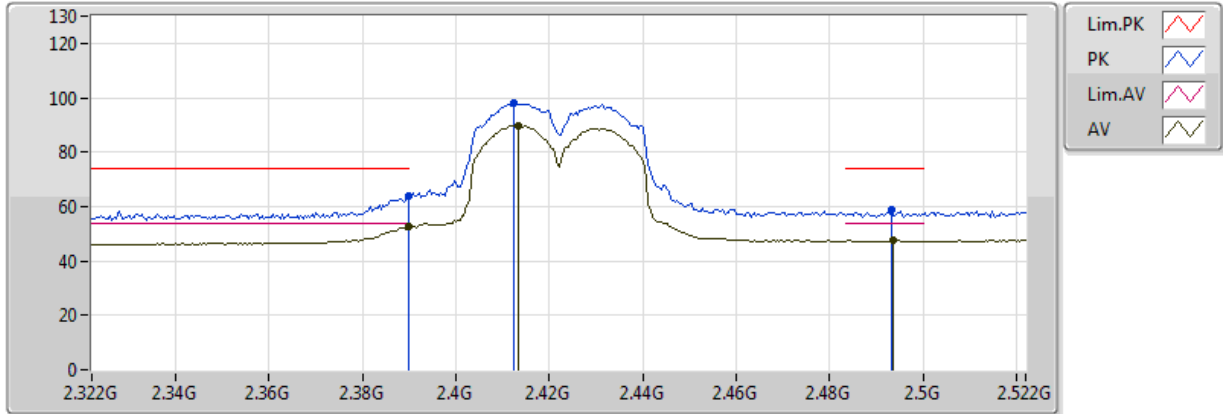

EUT = Z axis

Type	Freq(Hz)	Level(dBuV/m)	Limit(dBuV/m)	Margin(dB)	Factor(dB)	Dist(m)	Pol.(H/V)	Azimuth(°)	Height(m)	Comments
AV	2.39G	52.75	54.00	-1.25	31.17	3	V	182	2.07	-
AV	2.4132G	89.83	Inf	-Inf	31.26	3	V	182	2.07	-
AV	2.4936G	47.55	54.00	-6.45	31.57	3	V	182	2.07	-
PK	2.39G	63.62	74.00	-10.38	31.17	3	V	182	2.07	-
PK	2.4124G	97.89	Inf	-Inf	31.26	3	V	182	2.07	-
PK	2.4932G	58.68	74.00	-15.32	31.56	3	V	182	2.07	-

**802.11n HT40_Nss1,(MCS0)_2TX
2422MHz_TX**

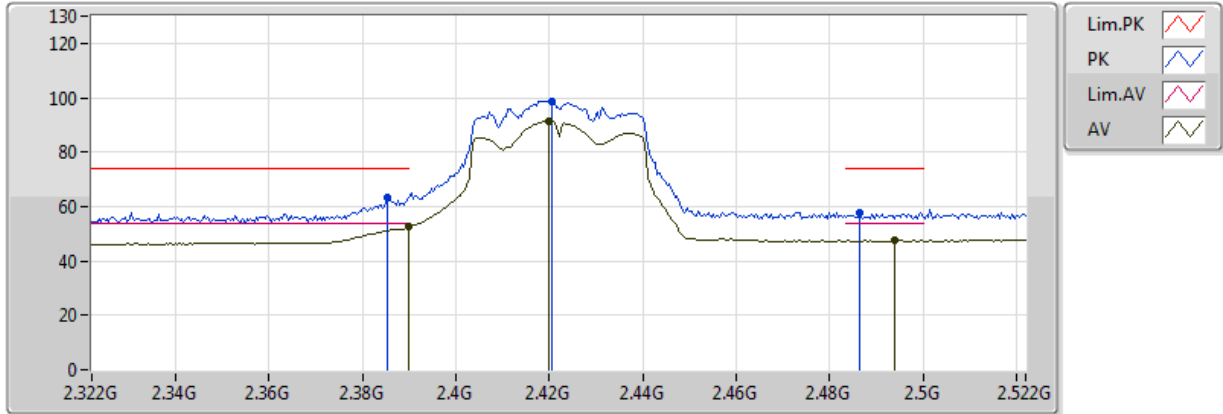

EUT = Z axis

Type	Freq(Hz)	Level(dBuV/m)	Limit(dBuV/m)	Margin(dB)	Factor(dB)	Dist(m)	Pol.(H/V)	Azimuth(°)	Height(m)	Comments
AV	2.42G	91.25	Inf	-Inf	31.29	3	H	289	3.58	-
AV	2.39G	52.64	54.00	-1.36	31.17	3	H	289	3.58	-
AV	2.494G	47.46	54.00	-6.54	31.57	3	H	289	3.58	-
PK	2.4204G	98.89	Inf	-Inf	31.29	3	H	289	3.58	-
PK	2.3852G	63.43	74.00	-10.57	31.15	3	H	289	3.58	-
PK	2.4864G	57.61	74.00	-16.39	31.54	3	H	289	3.58	-

802.11n HT40_Nss1,(MCS0)_2TX

2422MHz_TX

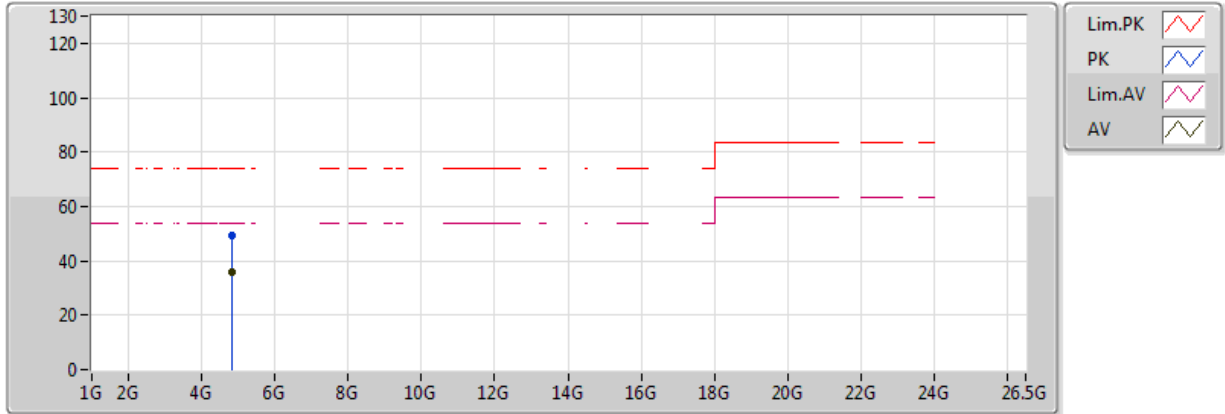

EUT = Z axis

Type	Freq(Hz)	Level(dBuV/m)	Limit(dBuV/m)	Margin(dB)	Factor(dB)	Dist(m)	Pol.(H/V)	Azimuth(°)	Height(m)	Comments
AV	4.844G	35.88	54.00	-18.12	2.51	3	V	342	3.63	-
PK	4.844G	49.35	74.00	-24.65	2.51	3	V	342	3.63	-

802.11n HT40_Nss1,(MCS0)_2TX

2422MHz_TX

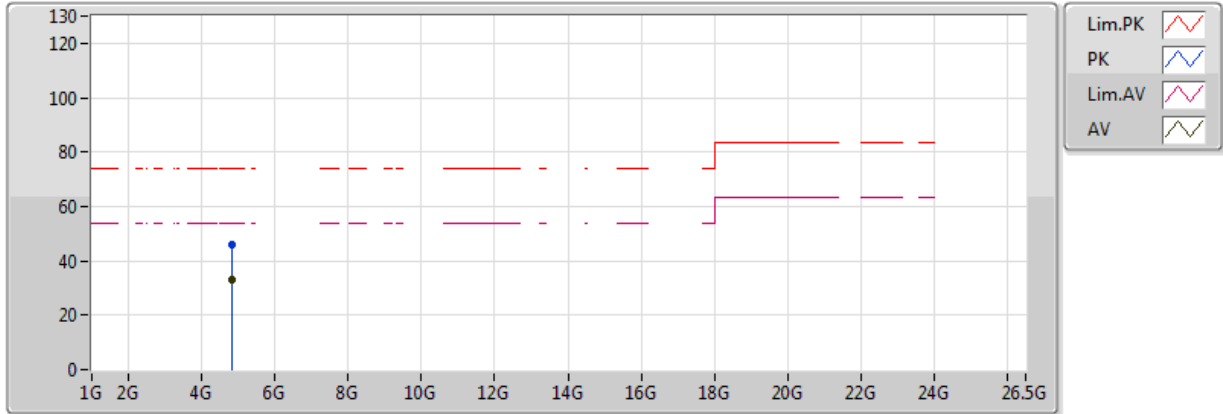

EUT = Z axis

Type	Freq(Hz)	Level(dBuV/m)	Limit(dBuV/m)	Margin(dB)	Factor(dB)	Dist(m)	Pol.(H/V)	Azimuth(°)	Height(m)	Comments
AV	4.844G	32.90	54.00	-21.10	2.51	3	H	128	3.69	-
PK	4.844G	46.05	74.00	-27.95	2.51	3	H	128	3.69	-

802.11n HT40_Nss1,(MCS0)_2TX

2437MHz_TX

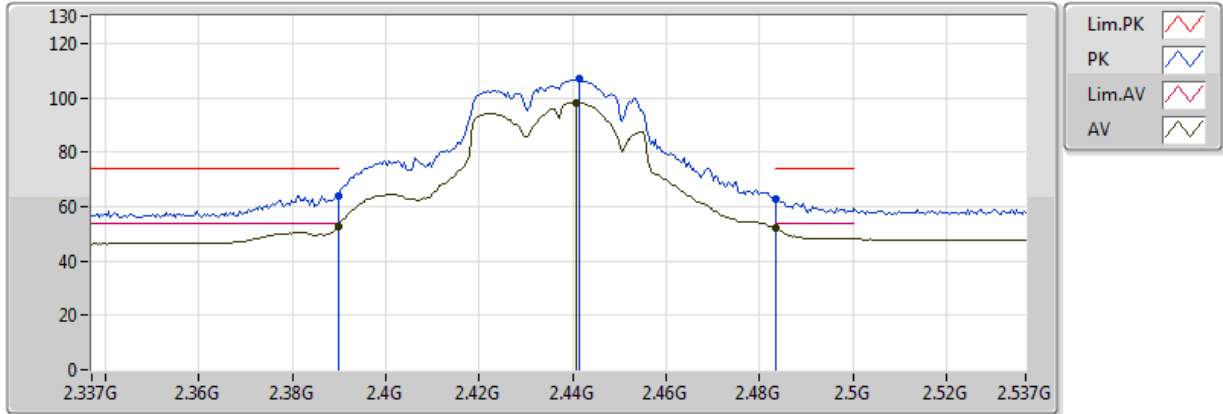

EUT = Z axis

Type	Freq(Hz)	Level(dBuV/m)	Limit(dBuV/m)	Margin(dB)	Factor(dB)	Dist(m)	Pol.(H/V)	Azimuth(°)	Height(m)	Comments
AV	2.389998G	52.92	54.00	-1.08	31.17	3	V	174	3.30	-
AV	2.4406G	98.18	Inf	-Inf	31.36	3	V	174	3.30	-
AV	2.483502G	51.99	54.00	-2.01	31.53	3	V	174	3.30	-
PK	2.389998G	64.05	74.00	-9.95	31.17	3	V	174	3.30	-
PK	2.4414G	106.80	Inf	-Inf	31.37	3	V	174	3.30	-
PK	2.483502G	62.64	74.00	-11.36	31.53	3	V	174	3.30	-

802.11n HT40_Nss1,(MCS0)_2TX

2437MHz_TX

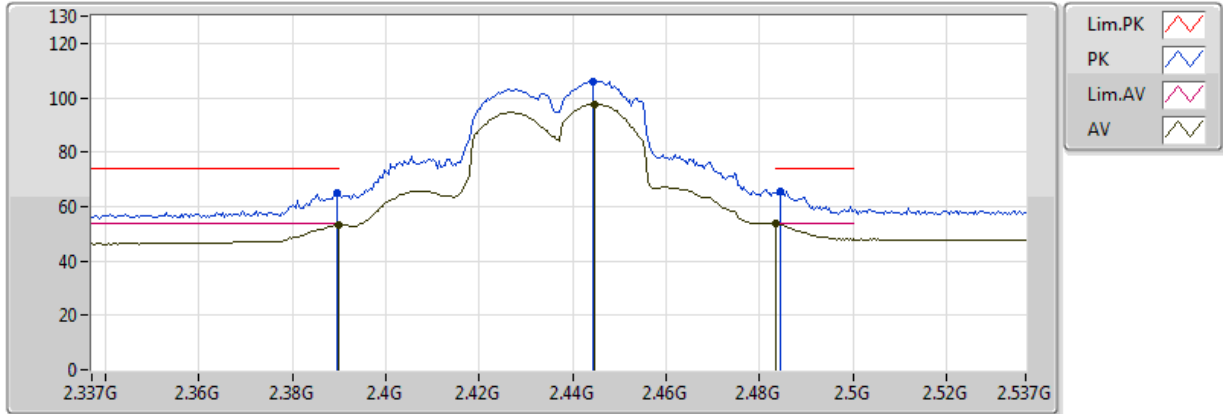

EUT = Z axis

Type	Freq(Hz)	Level(dBuV/m)	Limit(dBuV/m)	Margin(dB)	Factor(dB)	Dist(m)	Pol.(H/V)	Azimuth(°)	Height(m)	Comments
AV	2.389998G	53.31	54.00	-0.69	31.17	3	H	17	3.66	-
AV	2.4446G	97.70	Inf	-Inf	31.38	3	H	17	3.66	-
AV	2.483502G	53.61	54.00	-0.39	31.53	3	H	17	3.66	-
PK	2.3894G	64.99	74.00	-9.01	31.17	3	H	17	3.66	-
PK	2.4442G	105.94	Inf	-Inf	31.38	3	H	17	3.66	-
PK	2.4846G	65.66	74.00	-8.34	31.53	3	H	17	3.66	-

**802.11n HT40_Nss1,(MCS0)_2TX
2437MHz_TX**

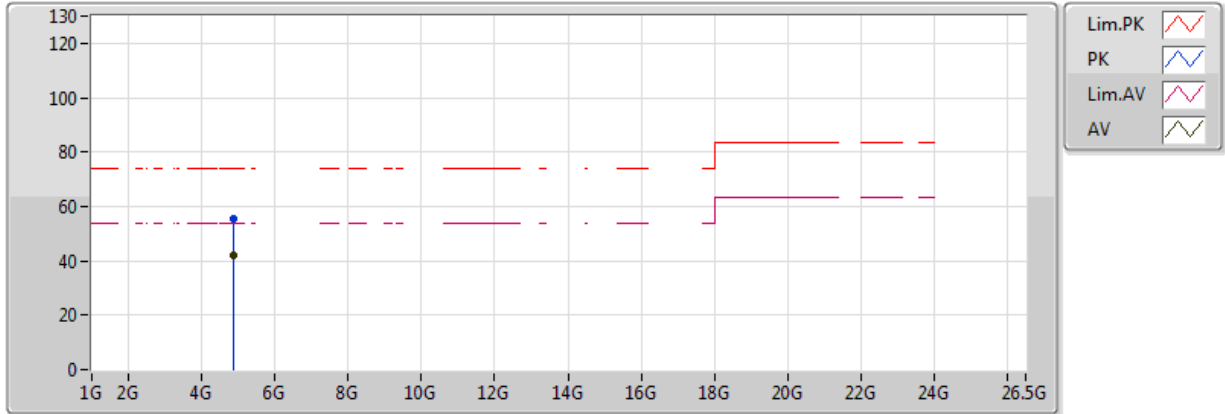

EUT = Z axis

Type	Freq(Hz)	Level(dBuV/m)	Limit(dBuV/m)	Margin(dB)	Factor(dB)	Dist(m)	Pol.(H/V)	Azimuth(°)	Height(m)	Comments
AV	4.874G	42.09	54.00	-11.91	2.55	3	V	339	3.59	-
PK	4.874G	55.61	74.00	-18.39	2.55	3	V	339	3.59	-

802.11n HT40_Nss1,(MCS0)_2TX

2437MHz_TX

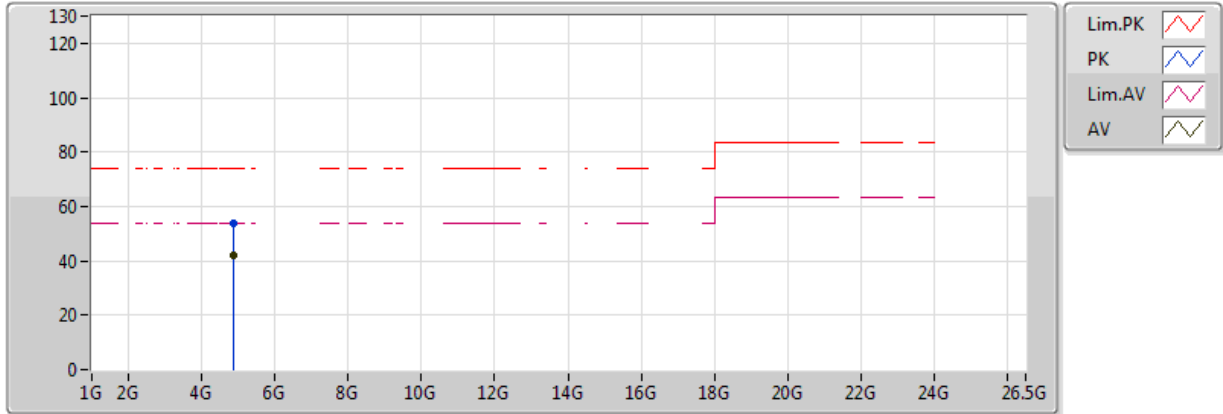

EUT = Z axis

Type	Freq(Hz)	Level(dBuV/m)	Limit(dBuV/m)	Margin(dB)	Factor(dB)	Dist(m)	Pol.(H/V)	Azimuth(°)	Height(m)	Comments
AV	4.874G	42.26	54.00	-11.74	2.55	3	H	176	3.24	-
PK	4.874G	53.97	74.00	-20.03	2.55	3	H	176	3.24	-

**802.11n HT40_Nss1,(MCS0)_2TX
2452MHz_TX**

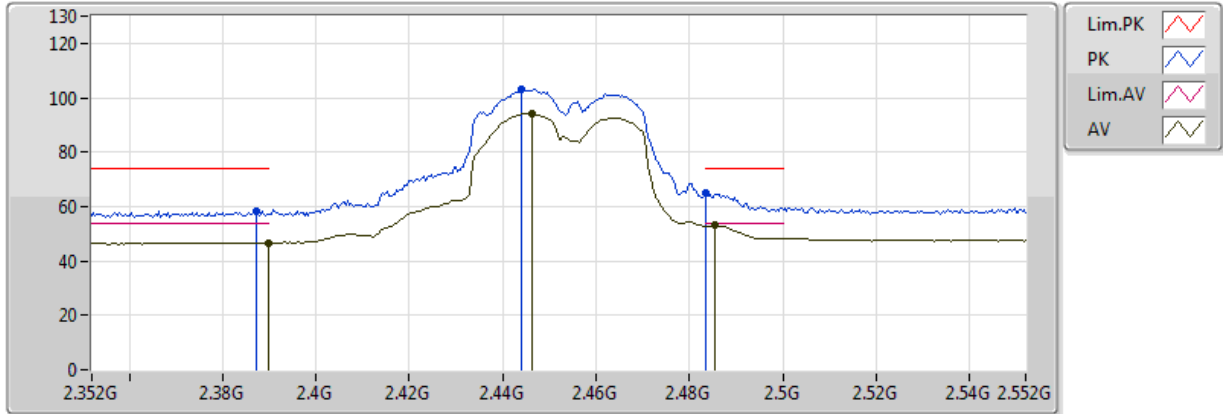

EUT = Z axis

Type	Freq(Hz)	Level(dBuV/m)	Limit(dBuV/m)	Margin(dB)	Factor(dB)	Dist(m)	Pol.(H/V)	Azimuth(°)	Height(m)	Comments
AV	2.39G	46.71	54.00	-7.29	31.17	3	V	176	3.22	-
AV	2.4464G	94.19	Inf	-Inf	31.39	3	V	176	3.22	-
AV	2.4856G	53.07	54.00	-0.93	31.54	3	V	176	3.22	-
PK	2.3872G	58.09	74.00	-15.91	31.16	3	V	176	3.22	-
PK	2.444G	103.28	Inf	-Inf	31.38	3	V	176	3.22	-
PK	2.4836G	64.81	74.00	-9.19	31.53	3	V	176	3.22	-

**802.11n HT40_Nss1,(MCS0)_2TX
2452MHz_TX**

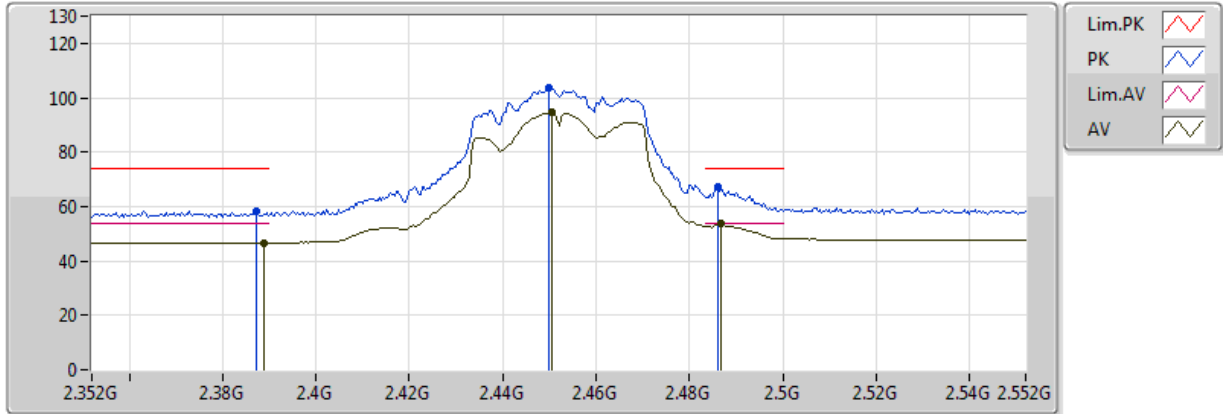

EUT = Z axis

Type	Freq(Hz)	Level(dBuV/m)	Limit(dBuV/m)	Margin(dB)	Factor(dB)	Dist(m)	Pol.(H/V)	Azimuth(°)	Height(m)	Comments
AV	2.3888G	46.67	54.00	-7.33	31.17	3	H	14	3.69	-
AV	2.4504G	94.51	Inf	-Inf	31.40	3	H	14	3.69	-
AV	2.4868G	53.53	54.00	-0.47	31.54	3	H	14	3.69	-
PK	2.3872G	58.08	74.00	-15.92	31.16	3	H	14	3.69	-
PK	2.45G	103.52	Inf	-Inf	31.40	3	H	14	3.69	-
PK	2.486G	67.28	74.00	-6.72	31.54	3	H	14	3.69	-

**802.11n HT40_Nss1,(MCS0)_2TX
2452MHz_TX**

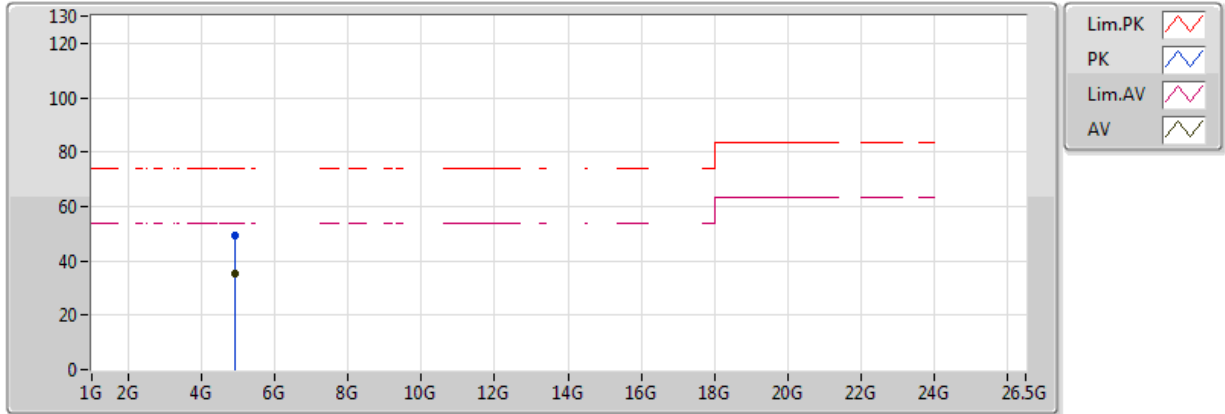

EUT = Z axis

Type	Freq(Hz)	Level(dBuV/m)	Limit(dBuV/m)	Margin(dB)	Factor(dB)	Dist(m)	Pol.(H/V)	Azimuth(°)	Height(m)	Comments
AV	4.904G	35.46	54.00	-18.54	2.60	3	V	185	2.96	-
PK	4.904G	49.09	74.00	-24.91	2.60	3	V	185	2.96	-

**802.11n HT40_Nss1,(MCS0)_2TX
2452MHz_TX**

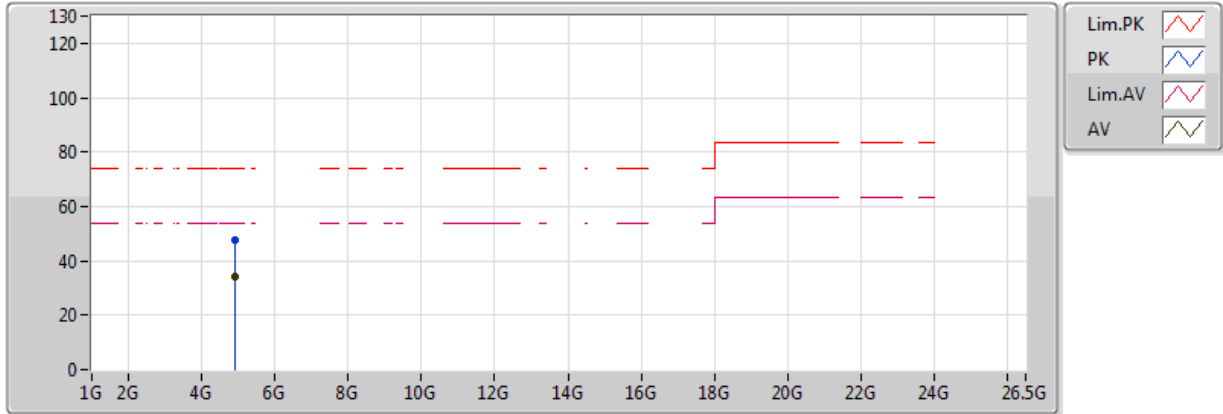

EUT = Z axis

Type	Freq(Hz)	Level(dBuV/m)	Limit(dBuV/m)	Margin(dB)	Factor(dB)	Dist(m)	Pol.(H/V)	Azimuth(°)	Height(m)	Comments
AV	4.904G	34.00	54.00	-20.00	2.60	3	H	170	3.66	-
PK	4.904G	47.74	74.00	-26.26	2.60	3	H	170	3.66	-