



EMC MEASUREMENT REPORT

Applicant: ALE USA Inc.
Address: 26801 West Agoura Road, Calabasas, CA 91301, United States
Product: OmniAccess Stellar
Model No.: OAW-AP1451
Brand Name: Alcatel-Lucent Enterprise
FCC Rule Part(s): FCC Part 15 Subpart B
Test Procedure: ANSI C63.4 - 2014
Result: Complies
Test Date: 2022-07-07 ~ 2022-07-12

Reviewed By: _____

Approved By: _____



The test results relate only to the samples tested.

This equipment has been shown to be capable of compliance with the applicable technical standards as indicated in the measurement report and was tested in accordance with the measurement procedures specified in ANSI C63.4-2014. Test results reported herein relate only to the item(s) tested.

The test report shall not be reproduced except in full without the written approval of MRT Technology (Suzhou) Co., Ltd.

Revision History

Report No.	Version	Description	Issue Date	Note
2203RSU064-U7	Rev. 01	Initial Report	2022-08-25	Valid

CONTENTS

Description	Page
1. General Information.....	4
1.1. Applicant	4
1.2. Manufacturer.....	4
1.3. Testing Facility	4
1.4. Product Information.....	5
2. Test Configuration	6
2.1. Test Mode	6
2.2. Configuration of Tested System	6
2.3. EMI Suppression Device(s)/Modifications	8
3. Measuring Instrument	9
4. Decision Rules and Measurement Uncertainty	10
4.1. Decision Rules	10
4.2. Measurement Uncertainty.....	10
5. Test Result.....	11
5.1. Summary.....	11
5.2. Conducted Emission	12
5.2.1. Test Limit	12
5.2.2. Test Setup	12
5.2.3. Test Result	13
5.3. Radiated Emission	19
5.3.1. Test Limit	19
5.3.2. Test Setup	20
5.3.3. Test Result	21
Appendix A - Test Setup Photograph	33
Appendix B - EUT Photograph.....	34

1.4. Product Information

Product Name	OmniAccess Stellar
Model No.	OAW-AP1451
EUT Identification No.	20220704Sample#06 (Normal Mode) 20220622Sample#08 (Receive only Mode)
Wi-Fi Specification	802.11a/b/g/n/ac/ax
Bluetooth Specification	V5.1 Single Mode
Power Type	AC Adapter Input or PoE Input
Operating Environment	Indoor Use
Accessories	
AC Adapter	Model: ADP-50GR B Input: 100-240V ~ 50/60Hz, 1.3A Output: 48.0V, 1.042A, 50.1W MAX
PoE Injector	Model: POE60U-1BT-X Input: 100-240V ~ 1.5A, 50/60Hz Output: 56.0V, 0.535A, 30W PIN 3, 6+ PIN 1, 2 Return Output: 56.0V, 0.535A, 30W PIN 4, 5+ PIN 7, 8 Return
Remark: 1. The information of EUT was provided by the manufacturer, and the accuracy of the information shall be the responsibility of the manufacturer. 2. AC Power Adapter and PoE Injector are not sold with Product.	

2. Test Configuration

2.1. Test Mode

Mode 1: Powered by AC Adapter + Ethernet ports communicate with PC + USB Flash Disk + 2.4G/5G/Scan Wi-Fi communicate with phones + 6G Wi-Fi communicates with notebook + Bluetooth communicates with phone.

Mode 2: Powered by PoE Adapter via Eth0 + Ethernet ports communicate with PC + USB Flash Disk + 2.4G/5G/Scan Wi-Fi communicate with phones + 6G Wi-Fi communicates with notebook + Bluetooth communicates with phone.

Mode 3: Receive by 2.4G Wi-Fi, 5G Wi-Fi, 6G Wi-Fi, Scan Wi-Fi and BLE.

2.2. Configuration of Tested System

The measurement procedures and appropriate EUT setup described in the ANSI C63.4-2014 was used in the measurement.

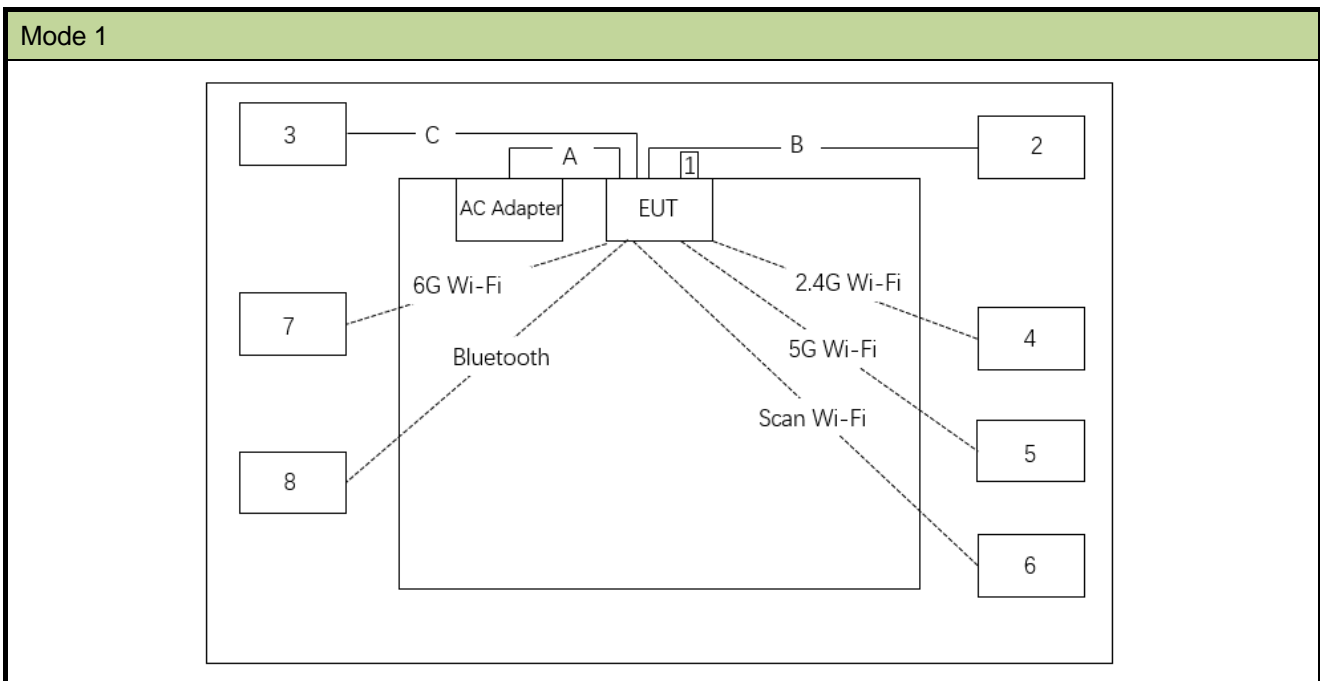

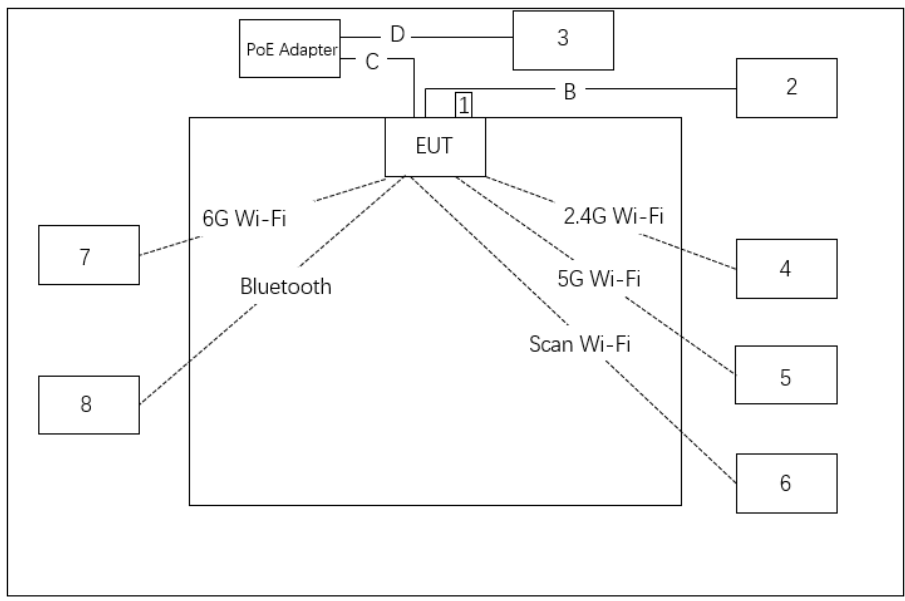
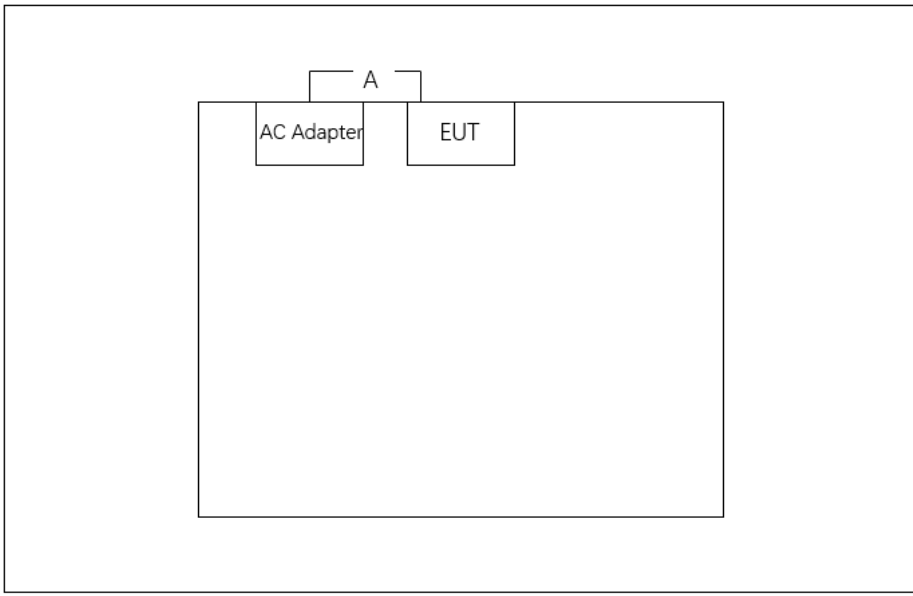
Mode 2

Mode 3

Cable Type		Cable Spec.	Length
A	Power Cable	Non-Shielding	1.75m
B	Ethernet Cable	Non-Shielding, CAT-6	>10.0m
C	Ethernet Cable	Non-Shielding, CAT-6	>10.0m
D	Ethernet Cable	Non-Shielding, CAT-6	>10.0m
Product		Manufacturer	Model No.
1	USB Flash Disk	SanDisk	N/A
2	Desktop	Dell	Inspiron 3670
3	Desktop	Dell	Vostro 270

4	Mobile phone	Oppo	X9009
5	Mobile phone	Apple	iPhone6s
6	Mobile phone	Apple	iPhone8
7	Mobile phone	China Mobile	M836
8	Notebook	Dell	P137G

2.3. EMI Suppression Device(s)/Modifications

No EMI suppression device(s) were added and/or no modifications were made during testing.

3. Measuring Instrument

Instrument Name	Manufacturer	Model No.	Asset No.	Cali. Interval	Cal. Due Date	Test Site
Two-Line V-Network	R&S	ENV216	MRTSUE06002	1 year	2023-06-04	WZ-SR2
Shielding Room	MIX-BEP	WZ-SR2	MRTSUE06215	N/A	N/A	WZ-SR2
Thermohygrometer	testo	608-H1	MRTSUE06404	1 year	2023-06-06	WZ-SR2
Four-Line V-Network	R&S	ENV432	MRTSUE06615	1 year	2022-10-13	WZ-SR2
EMI Test Receiver	R&S	ESR3	MRTSUE06909	1 year	2022-11-01	WZ-SR2
EMI Test Receiver	R&S	ESR7	MRTSUE06001	1 year	2022-12-29	WZ-AC1
Horn Antenna	Schwarzbeck	BBHA 9120D	MRTSUE06023	1 year	2022-09-16	WZ-AC1
Preamplifier	Agilent	83017A	MRTSUE06076	1 year	2022-11-12	WZ-AC1
TRILOG Antenna	Schwarzbeck	VULB 9168	MRTSUE06172	1 year	2023-06-21	WZ-AC1
Anechoic Chamber	TDK	WZ-AC1	MRTSUE06212	1 year	2023-04-21	WZ-AC1
Thermohygrometer	testo	608-H1	MRTSUE06403	1 year	2023-06-06	WZ-AC1
Signal Analyzer	Keysight	N9010B	MRTSUE06607	1 year	2022-12-29	WZ-AC1
Thermohygrometer	testo	Testo 608-H1	MRTSUE11039	1 year	2022-11-11	WZ-AC1
Horn Antenna	Schwarzbeck	BBHA 9170	MRTSUE06597	1 year	2022-12-01	WZ-AC1
Preamplifier	EMCI	EMC184045SE	MRTSUE06640	1 year	2023-01-13	WZ-AC1

Software	Version	Function
EMI Software	V3.0.0	EMI Test Software
Controller_MF 7802	2.03C	RE Antenna&turntable

4. Decision Rules and Measurement Uncertainty

4.1. Decision Rules

The Decision Rule is based on Simple Acceptance in accordance with ISO Guide 98-4: 2012 Clause 8.2. (Measurement uncertainty is not taken into account when stating conformity with a specified requirement.)

4.2. Measurement Uncertainty

Where relevant, the following test uncertainty levels have been estimated for tests performed on the EUT as specified in CISPR 16-4-2. This uncertainty represents an expanded uncertainty expressed at approximately the 95% confidence level using a coverage factor of $k = 2$.

Conducted Emission Measurement
The maximum measurement uncertainty is evaluated as: 9kHz~150kHz: 3.74dB 150kHz~30MHz: 3.44dB
Radiated Emission Measurement
The maximum measurement uncertainty is evaluated as: Horizontal: 30MHz~300MHz: 5.04dB 300MHz~1GHz: 4.95dB 1GHz~40GHz: 6.40dB Vertical: 30MHz~300MHz: 5.24dB 300MHz~1GHz: 6.03dB 1GHz~40GHz: 6.40dB

5. Test Result

5.1. Summary

FCC Part Section(s)	Test Description	Verdict
15.107	Conducted Emission	Pass
15.109	Radiated Emission	Pass

5.2. Conducted Emission

5.2.1. Test Limit

FCC Part 15.107 Conducted Emission Limits				
Frequency Range (MHz)	Class A Limits		Class B Limits	
	QP dB(μ V)	AV dB(μ V)	QP dB(μ V)	AV dB(μ V)
0.15 ~ 0.5	79	66	66 to 56	56 to 46
0.5 ~ 5	73	60	56	46
5 ~ 30	73	60	60	50

5.2.2. Test Setup

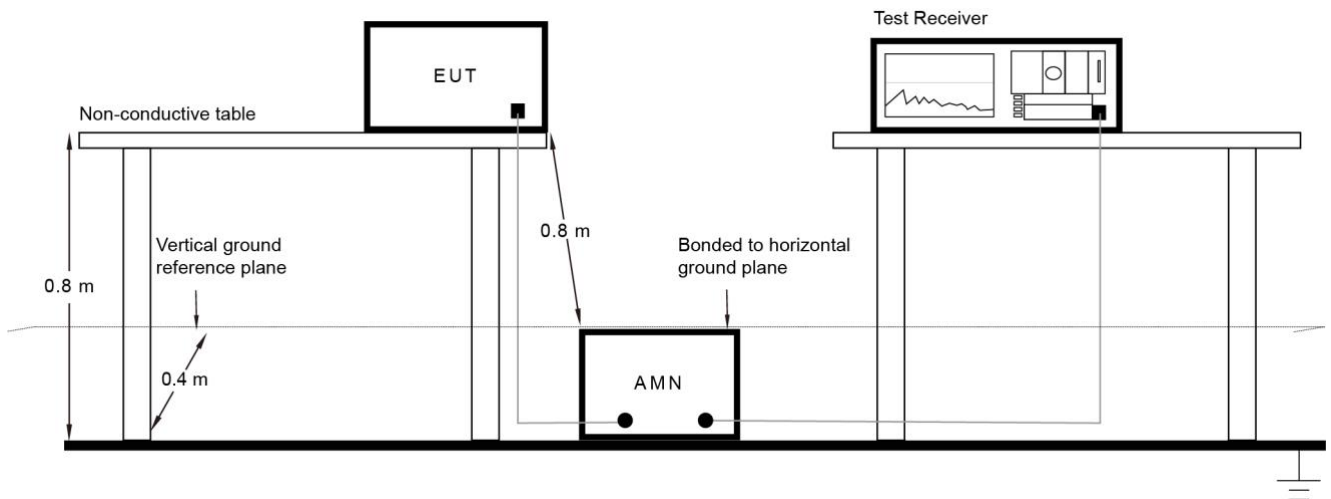

5.2.3. Test Result

Site: WZ-SR2	Date: 2022/07/07
Temperature: 23.1°C	Humidity: 59.7%
Limit: FCC_Part15.107_CE_AC Power_Class B	Engineer: Alin Zhou
Probe: ENV216_101683_Filter Off_C	Polarity: Line
EUT: OmniAccess Stellar	Power: AC 120V/60Hz
Test Mode 1	

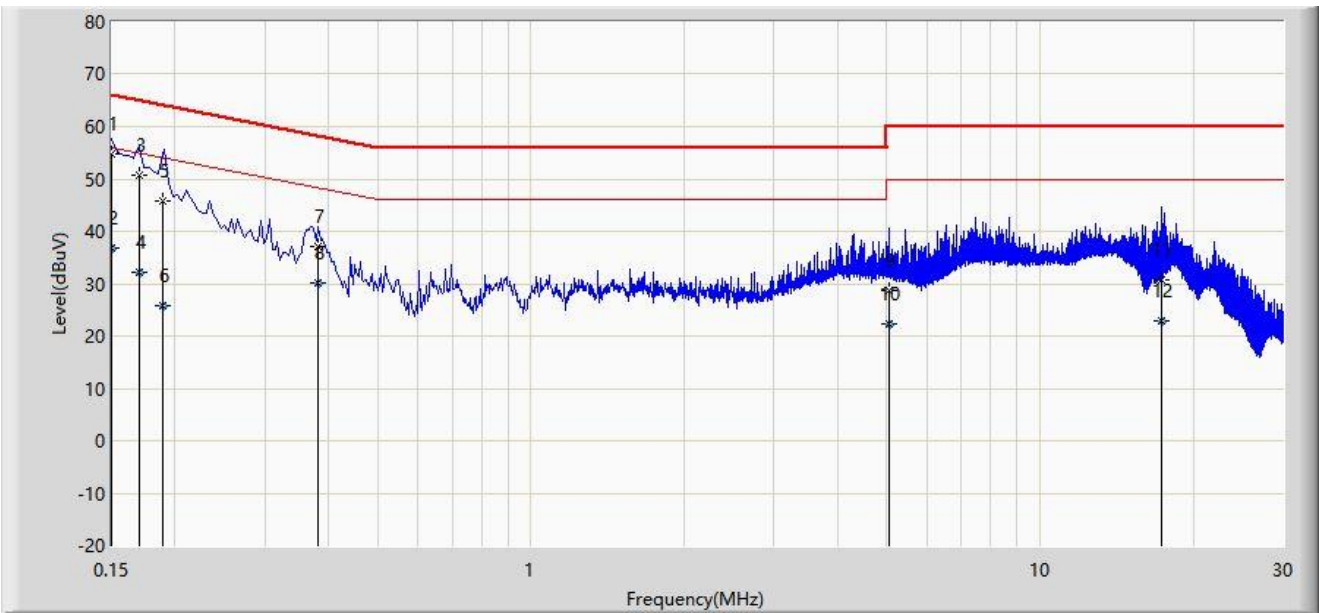

No	Mark	Frequency (MHz)	Measure Level (dBμV)	Reading Level (dBμV)	Margin (dB)	Limit (dBμV)	Factor (dB)	Type
1	*	0.150	54.723	44.995	-11.277	66.000	9.728	QP
2		0.150	36.791	27.064	-19.209	56.000	9.728	AV
3		0.170	50.590	40.860	-14.371	64.960	9.730	QP
4		0.170	32.130	22.400	-22.830	54.960	9.730	AV
5		0.189	45.805	36.075	-18.285	64.090	9.730	QP
6		0.189	25.903	16.173	-28.187	54.090	9.730	AV
7		0.382	37.103	27.336	-21.133	58.236	9.767	QP
8		0.382	30.224	20.458	-18.012	48.236	9.767	AV
9		5.050	28.597	18.245	-31.403	60.000	10.352	QP
10		5.050	22.181	11.829	-27.819	50.000	10.352	AV
11		17.318	30.752	20.040	-29.248	60.000	10.712	QP
12		17.318	22.999	12.286	-27.001	50.000	10.712	AV

Note 1: " * ", means this data is the worst emission level.

Note 2: Measure Level (dBμV) = Reading Level (dBμV) + Factor (dB).

Note 3: Factor (dB) = Cable Loss (dB) + LISN Factor (dB).

Site: WZ-SR2	Date: 2022/07/07
Temperature: 23.1°C	Humidity: 59.7%
Limit: FCC_Part15.107_CE_AC Power_Class B	Engineer: Alin Zhou
Probe: ENV216_101683_Filter Off_C	Polarity: Neutral
EUT: OmniAccess Stellar	Power: AC 120V/60Hz
Test Mode 1	

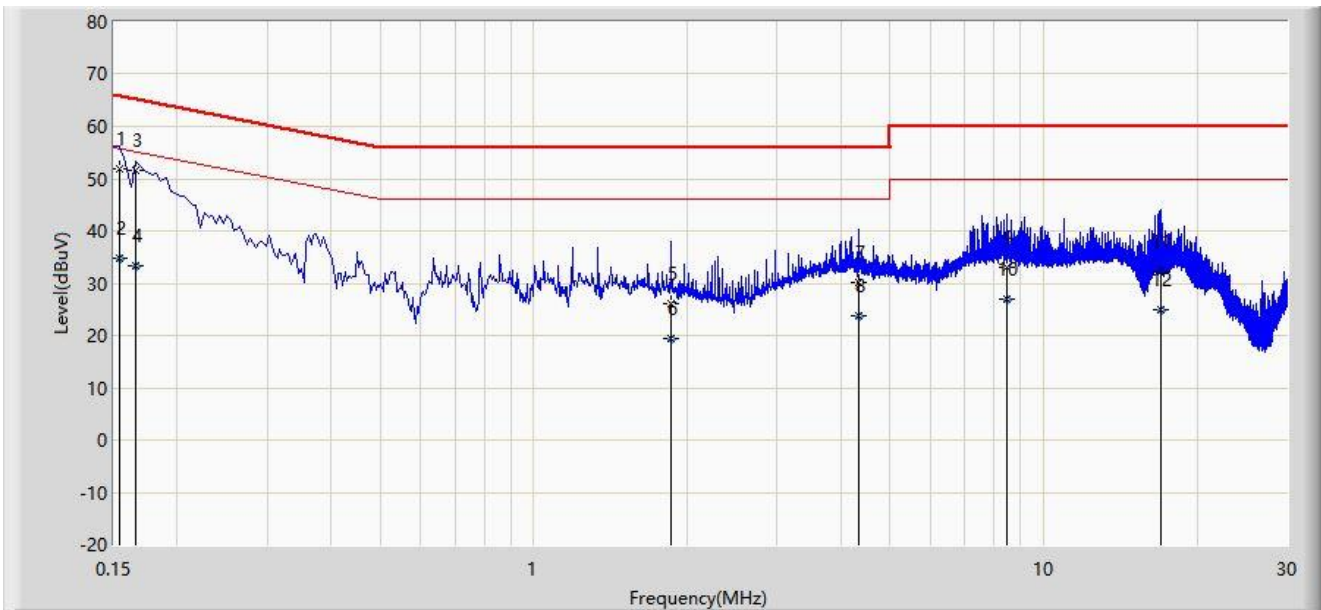

No	Mark	Frequency (MHz)	Measure Level (dBμV)	Reading Level (dBμV)	Margin (dB)	Limit (dBμV)	Factor (dB)	Type
1		0.154	51.927	42.166	-13.868	65.795	9.761	QP
2		0.154	34.802	25.041	-20.993	55.795	9.761	AV
3	*	0.166	51.453	41.690	-13.705	65.158	9.763	QP
4		0.166	33.358	23.595	-21.800	55.158	9.763	AV
5		1.858	26.139	16.283	-29.861	56.000	9.856	QP
6		1.858	19.532	9.676	-26.468	46.000	9.856	AV
7		4.342	30.091	19.826	-25.909	56.000	10.265	QP
8		4.342	23.730	13.464	-22.270	46.000	10.265	AV
9		8.442	32.952	22.410	-27.048	60.000	10.542	QP
10		8.442	26.812	16.269	-23.188	50.000	10.542	AV
11		17.018	32.317	21.625	-27.683	60.000	10.692	QP
12		17.018	24.886	14.194	-25.114	50.000	10.692	AV

Note 1: " * ", means this data is the worst emission level.

Note 2: Measure Level (dBμV) = Reading Level (dBμV) + Factor (dB).

Note 3: Factor (dB) = Cable Loss (dB) + LISN Factor (dB).

Site: WZ-SR2	Date: 2022/07/07
Temperature: 23.1°C	Humidity: 59.7%
Limit: FCC_Part15.107_CE_AC Power_Class B	Engineer: Alin Zhou
Probe: ENV216_101683_Filter Off_C	Polarity: Line
EUT: OmniAccess Stellar	Power: AC 120V/60Hz
Test Mode 2	

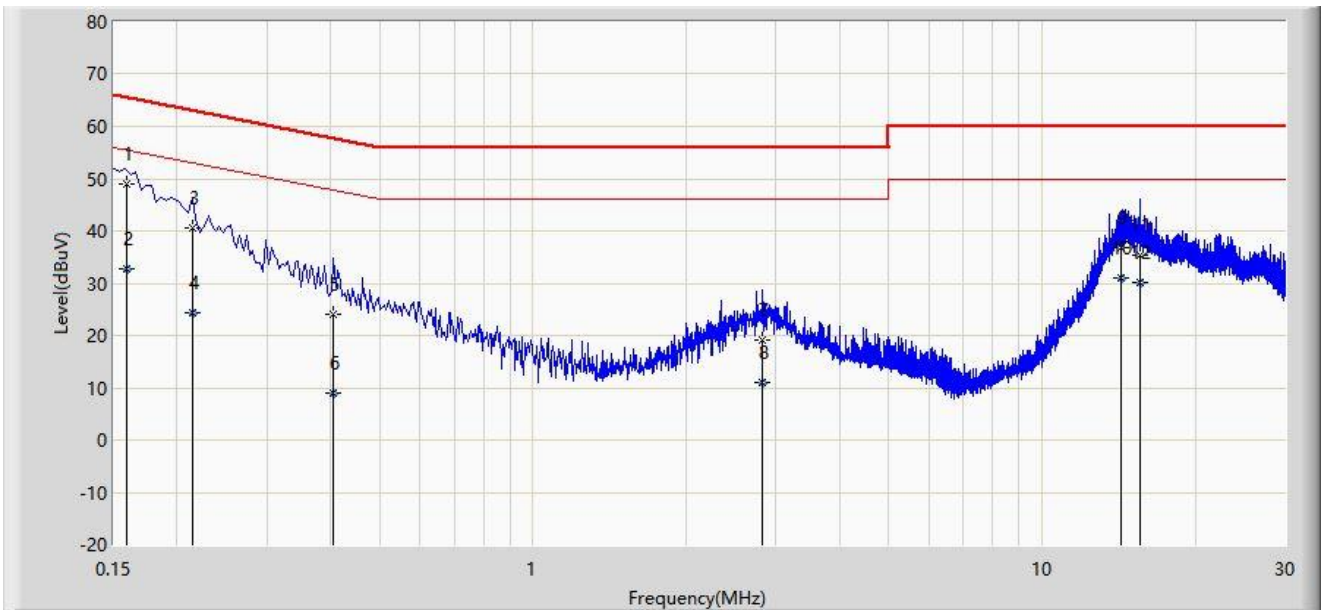

No	Mark	Frequency (MHz)	Measure Level (dBμV)	Reading Level (dBμV)	Margin (dB)	Limit (dBμV)	Factor (dB)	Type
1	*	0.159	48.953	39.223	-16.569	65.522	9.730	QP
2		0.159	32.829	23.099	-22.693	55.522	9.730	AV
3		0.214	40.443	30.709	-22.606	63.049	9.734	QP
4		0.214	24.225	14.492	-28.823	53.049	9.734	AV
5		0.406	23.943	14.172	-33.787	57.730	9.771	QP
6		0.406	9.127	-0.645	-38.603	47.730	9.771	AV
7		2.822	19.250	9.270	-36.750	56.000	9.980	QP
8		2.822	10.954	0.974	-35.046	46.000	9.980	AV
9		14.266	36.730	26.122	-23.270	60.000	10.608	QP
10		14.266	31.107	20.498	-18.893	50.000	10.608	AV
11		15.570	35.460	24.825	-24.540	60.000	10.635	QP
12		15.570	30.128	19.493	-19.872	50.000	10.635	AV

Note 1: " * ", means this data is the worst emission level.

Note 2: Measure Level (dBμV) = Reading Level (dBμV) + Factor (dB).

Note 3: Factor (dB) = Cable Loss (dB) + LISN Factor (dB).

Site: WZ-SR2	Date: 2022/07/07
Temperature: 23.1°C	Humidity: 59.7%
Limit: FCC_Part15.107_CE_AC Power_Class B	Engineer: Alin Zhou
Probe: ENV216_101683_Filter Off_C	Polarity: Neutral
EUT: OmniAccess Stellar	Power: AC 120V/60Hz
Test Mode 2	

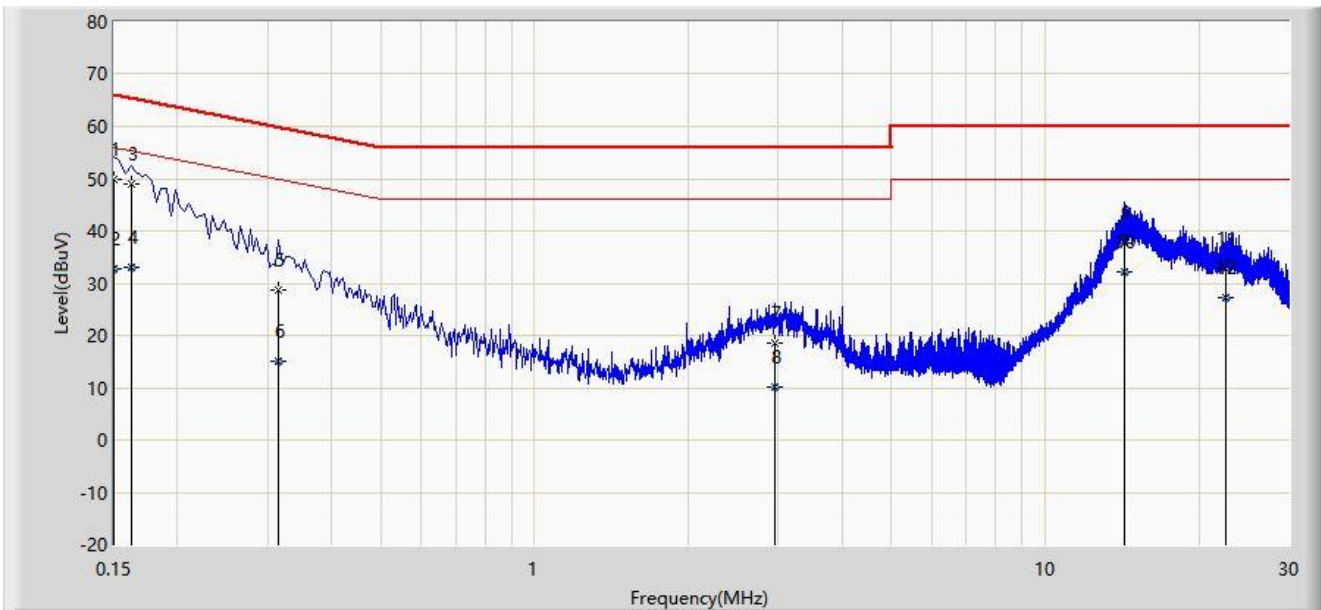

No	Mark	Frequency (MHz)	Measure Level (dBµV)	Reading Level (dBµV)	Margin (dB)	Limit (dBµV)	Factor (dB)	Type
1	*	0.150	49.970	40.209	-16.030	66.000	9.760	QP
2		0.150	32.661	22.901	-23.339	56.000	9.760	AV
3		0.162	49.005	39.242	-16.356	65.361	9.763	QP
4		0.162	33.119	23.357	-22.242	55.361	9.763	AV
5		0.314	28.607	18.814	-31.257	59.864	9.793	QP
6		0.314	14.995	5.202	-34.869	49.864	9.793	AV
7		2.950	18.647	8.623	-37.353	56.000	10.024	QP
8		2.950	10.212	0.187	-35.788	46.000	10.024	AV
9		14.314	37.607	26.986	-22.393	60.000	10.621	QP
10		14.314	32.064	21.443	-17.936	50.000	10.621	AV
11		22.638	32.614	21.677	-27.386	60.000	10.938	QP
12		22.638	27.260	16.323	-22.740	50.000	10.938	AV

Note 1: " * ", means this data is the worst emission level.

Note 2: Measure Level (dBµV) = Reading Level (dBµV) + Factor (dB).

Note 3: Factor (dB) = Cable Loss (dB) + LISN Factor (dB).

Site: WZ-SR2	Date: 2022/07/12
Temperature: 25.1°C	Humidity: 54.1%
Limit: FCC_Part15.107_CE_AC Power_Class B	Engineer: Alin Zhou
Probe: ENV216_101683_Filter Off_C	Polarity: Line
EUT: OmniAccess Stellar	Power: AC 120V/60Hz
Test Mode 3	

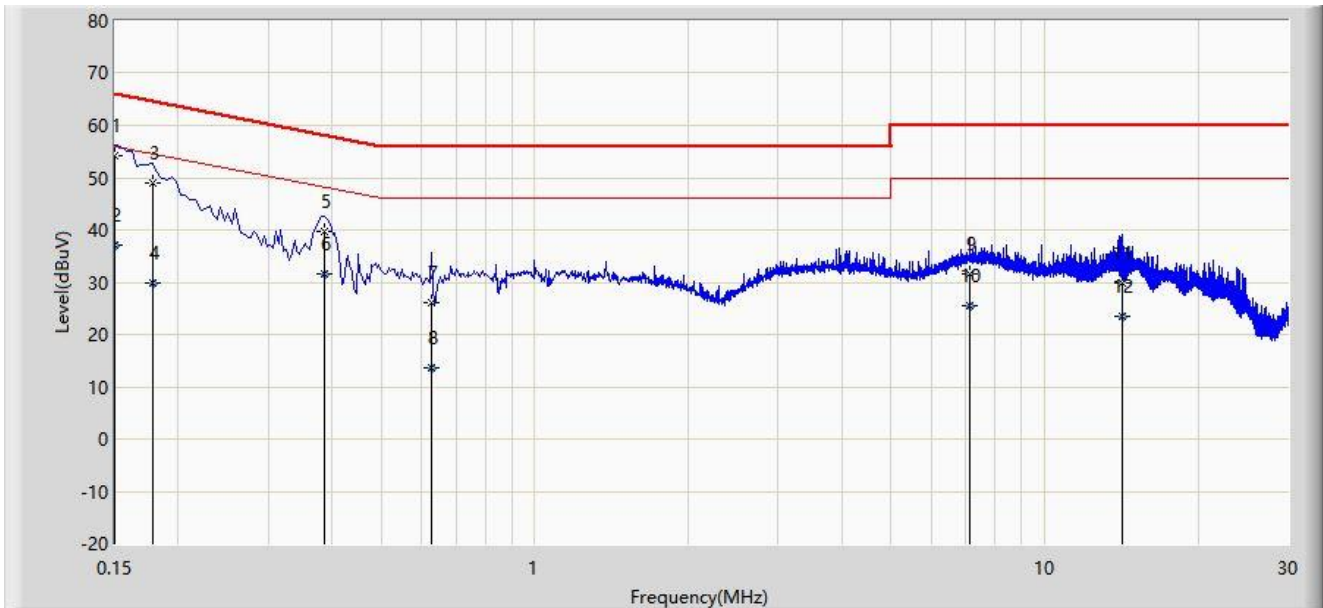

No	Mark	Frequency (MHz)	Measure Level (dBμV)	Reading Level (dBμV)	Margin (dB)	Limit (dBμV)	Factor (dB)	Type
1	*	0.150	54.155	44.427	-11.845	66.000	9.728	QP
2		0.150	37.185	27.457	-18.815	56.000	9.728	AV
3		0.178	48.987	39.257	-15.591	64.578	9.730	QP
4		0.178	29.790	20.060	-24.788	54.578	9.730	AV
5		0.386	39.778	30.011	-18.371	58.149	9.767	QP
6		0.386	31.623	21.856	-16.526	48.149	9.767	AV
7		0.626	26.022	16.195	-29.978	56.000	9.827	QP
8		0.626	13.591	3.764	-32.409	46.000	9.827	AV
9		7.130	31.585	21.137	-28.415	60.000	10.448	QP
10		7.130	25.638	15.190	-24.362	50.000	10.448	AV
11		14.170	29.715	19.107	-30.285	60.000	10.608	QP
12		14.170	23.386	12.778	-26.614	50.000	10.608	AV

Note 1: " * ", means this data is the worst emission level.

Note 2: Measure Level (dBμV) = Reading Level (dBμV) + Factor (dB).

Note 3: Factor (dB) = Cable Loss (dB) + LISN Factor (dB).

Site: WZ-SR2	Date: 2022/07/12
Temperature: 25.1°C	Humidity: 54.1%
Limit: FCC_Part15.107_CE_AC Power_Class B	Engineer: Alin Zhou
Probe: ENV216_101683_Filter Off_C	Polarity: Neutral
EUT: OmniAccess Stellar	Power: AC 120V/60Hz
Test Mode 3	

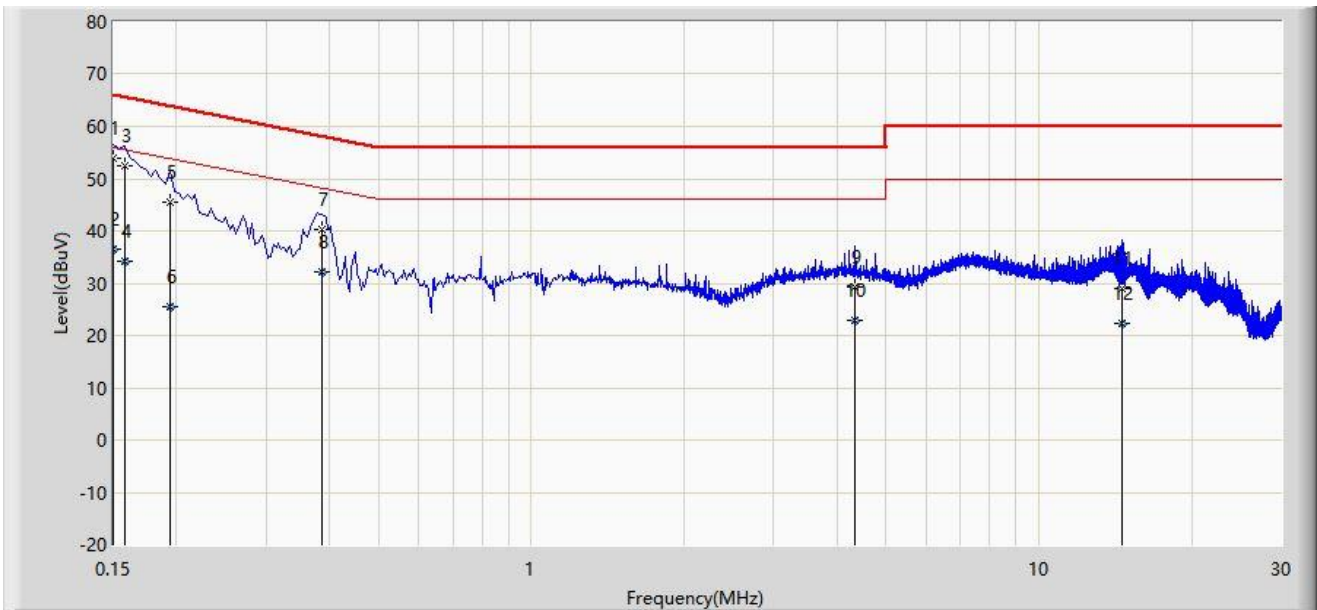

No	Mark	Frequency (MHz)	Measure Level (dB μ V)	Reading Level (dB μ V)	Margin (dB)	Limit (dB μ V)	Factor (dB)	Type
1	*	0.150	53.955	44.195	-12.045	66.000	9.760	QP
2		0.150	36.656	26.896	-19.344	56.000	9.760	AV
3		0.158	52.568	42.806	-13.001	65.568	9.762	QP
4		0.158	34.275	24.513	-21.294	55.568	9.762	AV
5		0.194	45.367	35.598	-18.496	63.864	9.769	QP
6		0.194	25.491	15.722	-28.372	53.864	9.769	AV
7		0.386	40.283	30.476	-17.866	58.149	9.807	QP
8		0.386	32.088	22.281	-16.061	48.149	9.807	AV
9		4.334	29.268	19.004	-26.732	56.000	10.264	QP
10		4.334	22.988	12.724	-23.012	46.000	10.264	AV
11		14.554	29.063	18.442	-30.937	60.000	10.621	QP
12		14.554	22.394	11.773	-27.606	50.000	10.621	AV

Note 1: " * ", means this data is the worst emission level.

Note 2: Measure Level (dB μ V) = Reading Level (dB μ V) + Factor (dB).

Note 3: Factor (dB) = Cable Loss (dB) + LISN Factor (dB).

5.3. Radiated Emission

5.3.1. Test Limit

FCC Part 15.109 Class B Limits		
Frequency (MHz)	Distance (m)	Level (dB μ V/m)
30 - 88	3	40
88 - 216	3	43.5
216 - 960	3	46
Above 960	3	54

Note 1: The lower limit shall apply at the transition frequency.

Note 2: Distance refers to the distance in meters between the measuring instrument antenna and the closed point of any part of the device or system.

Note 3: E field strength (dB μ V/m) = 20 log E field strength (μ V/m)

5.3.2. Test Setup

Below 1GHz Test Setup:

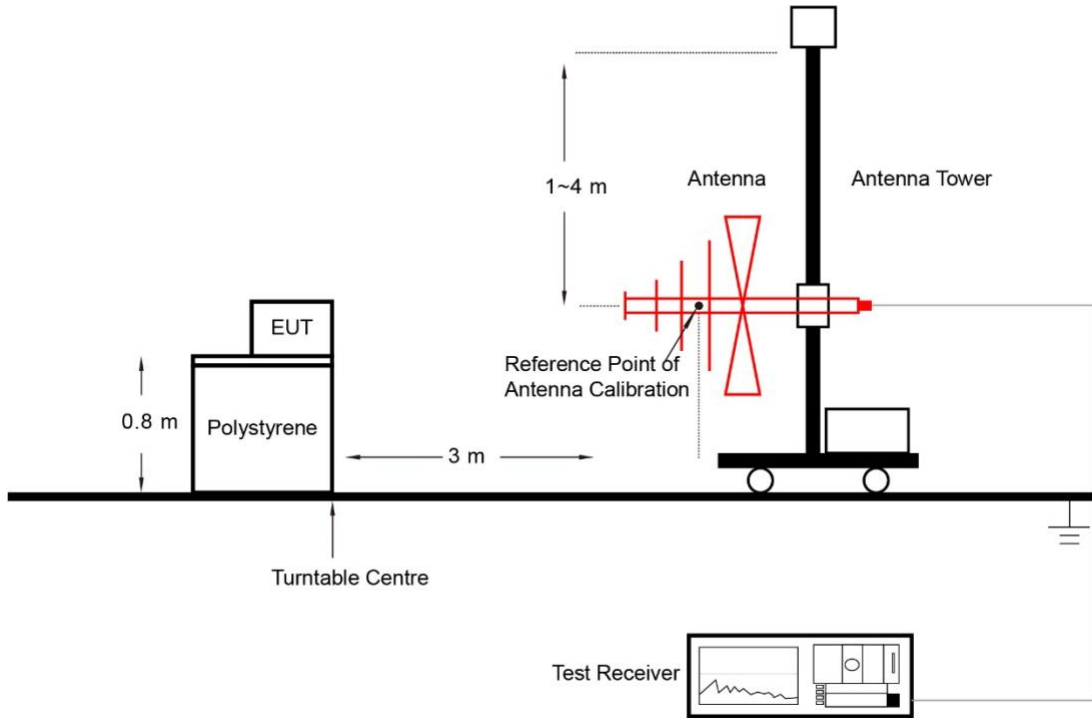

Above 1GHz Test Setup:

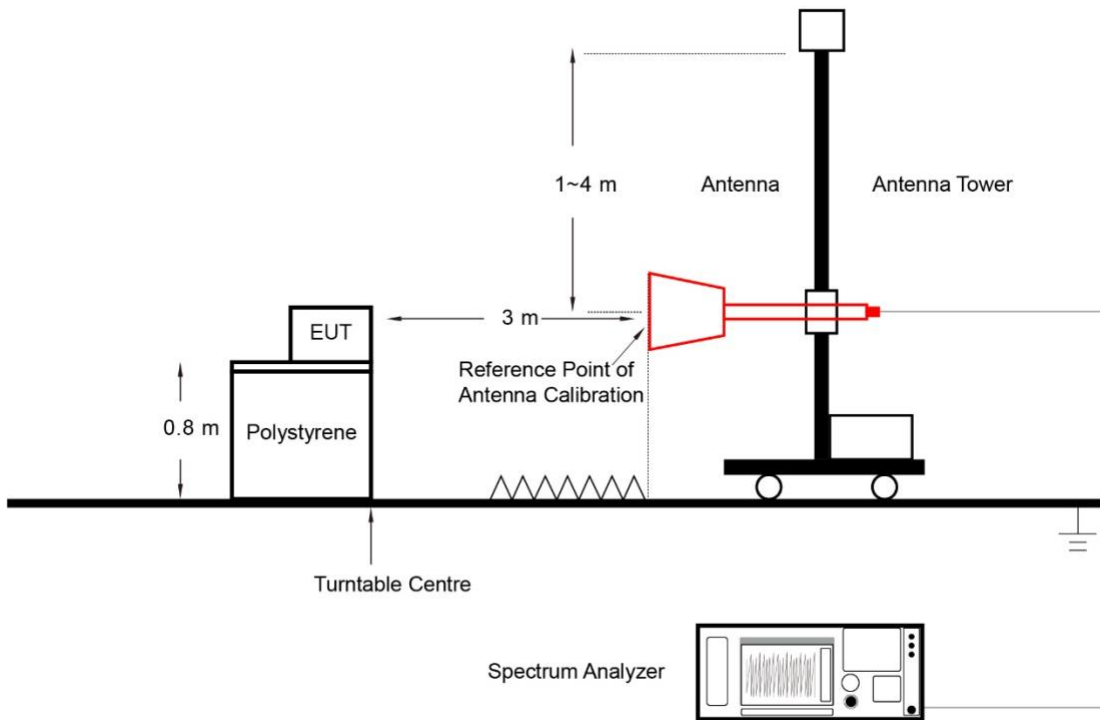

5.3.3. Test Result

Site: WZ-AC1	Date: 2022/07/12
Temperature: 28.4°C	Humidity: 60.6%
Limit: FCC_Part15.109_RE(3m)_Class B	Engineer: Bob Zhang
Probe: VULB 9168_25-2000MHz	Polarity: Horizontal
EUT: OmniAccess Stellar	Power: AC 120V/60Hz
Test Mode 1	

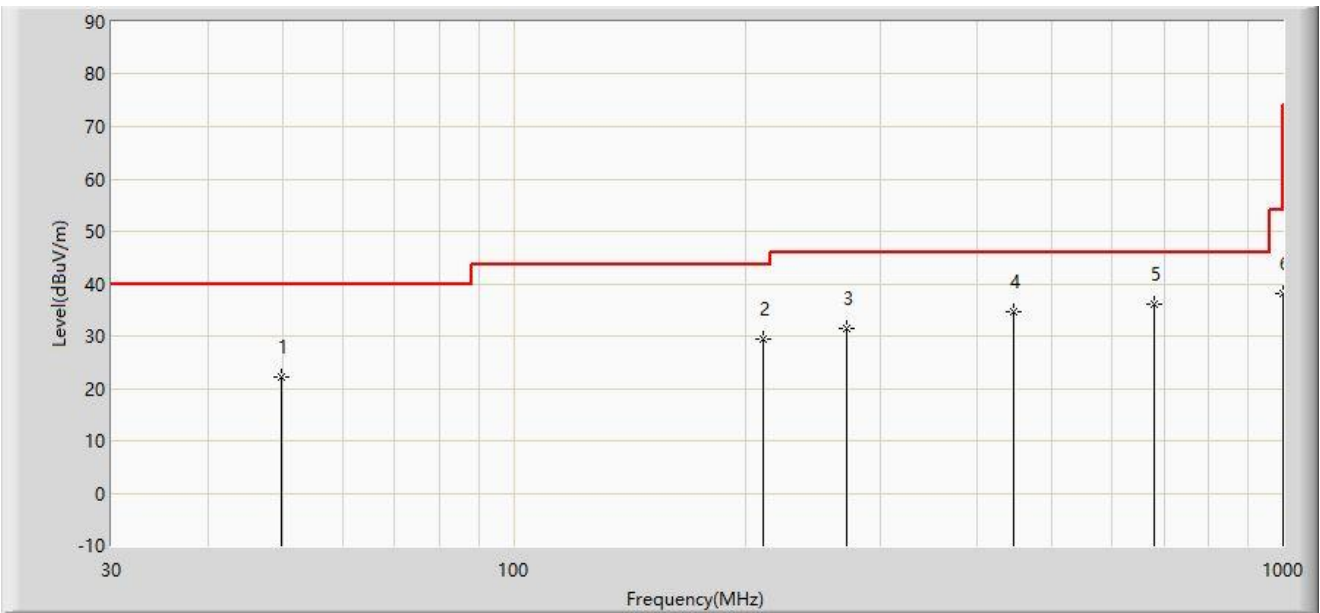

No	Mark	Frequency (MHz)	Measure Level (dBμV/m)	Reading Level (dBμV)	Margin (dB)	Limit (dBμV/m)	Factor (dB/m)	Type
1		49.885	22.160	3.919	-17.840	40.000	18.241	PK
2		211.390	29.438	14.781	-14.062	43.500	14.657	PK
3		270.560	31.369	13.875	-14.631	46.000	17.494	PK
4		447.100	34.667	12.493	-11.333	46.000	22.174	PK
5	*	679.900	35.970	9.786	-10.030	46.000	26.184	PK
6		1000.000	38.150	7.811	-15.850	54.000	30.339	PK

Note 1: " * ", means this data is the worst emission level.

Note 2: Measure Level (dBμV/m) = Reading Level (dBμV) + Factor (dB/m).

Note 3: Factor (dB/m) = Cable Loss (dB) + Antenna Factor (dB/m).

Note 4: Quasi-Peak measurement was not performed when peak measure level was lower than the quasi-peak limit.

Site: WZ-AC1	Date: 2022/07/12
Temperature: 28.4°C	Humidity: 60.6%
Limit: FCC_Part15.109_RE(3m)_Class B	Engineer: Bob Zhang
Probe: VULB 9168_25-2000MHz	Polarity: Vertical
EUT: OmniAccess Stellar	Power: AC 120V/60Hz
Test Mode 1	

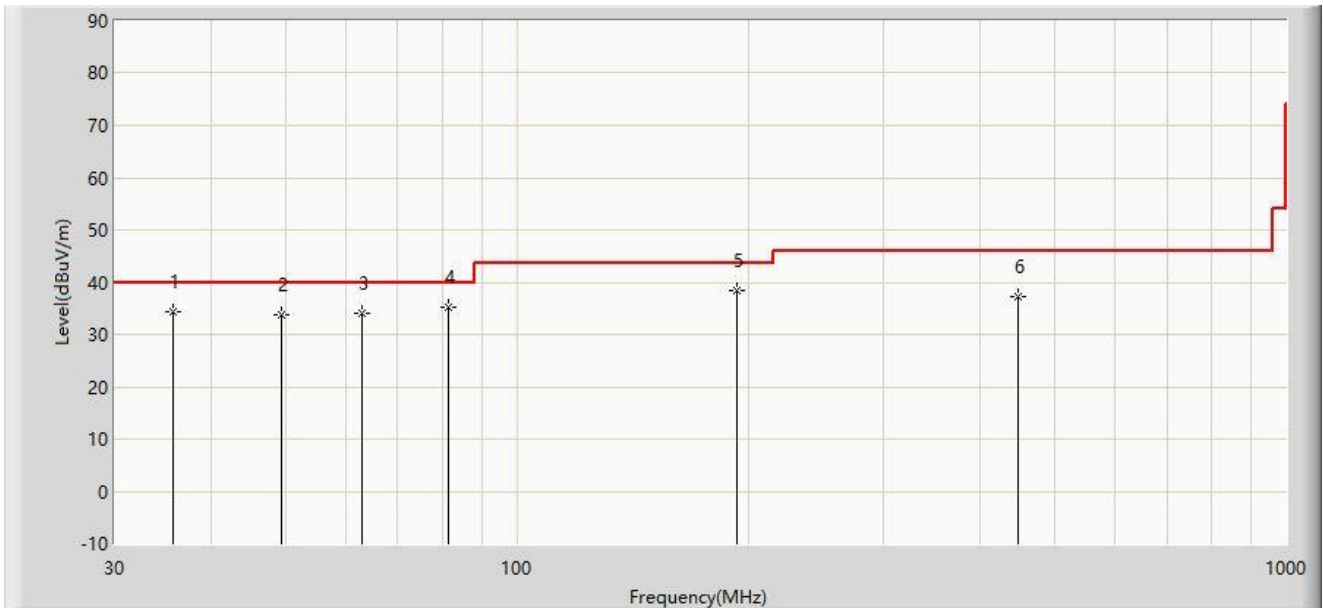

No	Mark	Frequency (MHz)	Measure Level (dB μ V/m)	Reading Level (dB μ V)	Margin (dB)	Limit (dB μ V/m)	Factor (dB/m)	Type
1		35.820	34.320	16.520	-5.680	40.000	17.800	PK
2		49.400	33.682	15.419	-6.318	40.000	18.263	PK
3		62.980	34.102	16.917	-5.898	40.000	17.185	PK
4	*	81.410	35.262	21.643	-4.738	40.000	13.619	PK
5		192.960	38.297	23.130	-5.203	43.500	15.167	PK
6		448.070	37.172	14.964	-8.828	46.000	22.208	PK

Note 1: " * ", means this data is the worst emission level.

Note 2: Measure Level (dB μ V/m) = Reading Level (dB μ V) + Factor (dB/m).

Note 3: Factor (dB/m) = Cable Loss (dB) + Antenna Factor (dB/m).

Note 4: Quasi-Peak measurement was not performed when peak measure level was lower than the quasi-peak limit.

Site: WZ-AC1	Date: 2022/07/12
Temperature: 28.4°C	Humidity: 60.6%
Limit: FCC_Part15.109_RE(3m)_Class B	Engineer: Bob Zhang
Probe: VULB 9168_25-2000MHz	Polarity: Horizontal
EUT: OmniAccess Stellar	Power: By PoE
Test Mode 2	

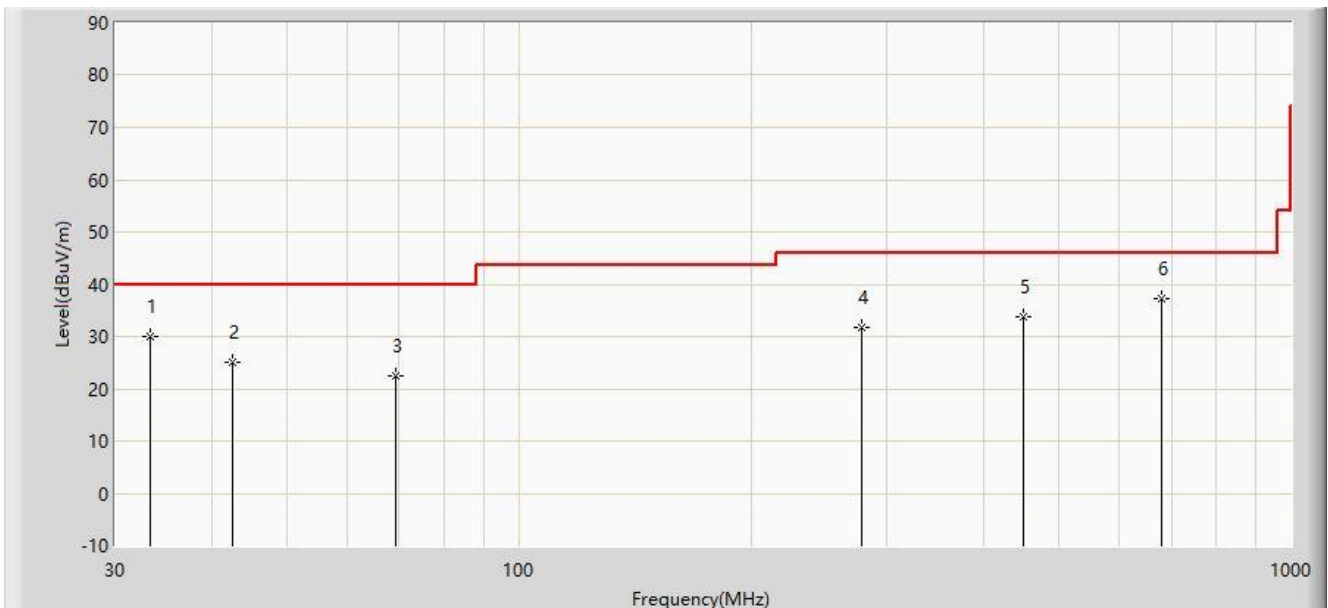

No	Mark	Frequency (MHz)	Measure Level (dB μ V/m)	Reading Level (dB μ V)	Margin (dB)	Limit (dB μ V/m)	Factor (dB/m)	Type
1		33.395	29.968	12.485	-10.032	40.000	17.482	PK
2		42.610	24.948	6.598	-15.052	40.000	18.350	PK
3		69.285	22.557	6.270	-17.443	40.000	16.286	PK
4		278.320	31.691	13.779	-14.309	46.000	17.912	PK
5		449.525	33.685	11.431	-12.315	46.000	22.254	PK
6	*	679.900	37.386	11.202	-8.614	46.000	26.184	PK

Note 1: " * ", means this data is the worst emission level.

Note 2: Measure Level (dB μ V/m) = Reading Level (dB μ V) + Factor (dB/m).

Note 3: Factor (dB/m) = Cable Loss (dB) + Antenna Factor (dB/m).

Note 4: Quasi-Peak measurement was not performed when peak measure level was lower than the quasi-peak limit.

Site: WZ-AC1	Date: 2022/07/12
Temperature: 28.4°C	Humidity: 60.6%
Limit: FCC_Part15.109_RE(3m)_Class B	Engineer: Bob Zhang
Probe: VULB 9168_25-2000MHz	Polarity: Vertical
EUT: OmniAccess Stellar	Power: By PoE
Test Mode 2	

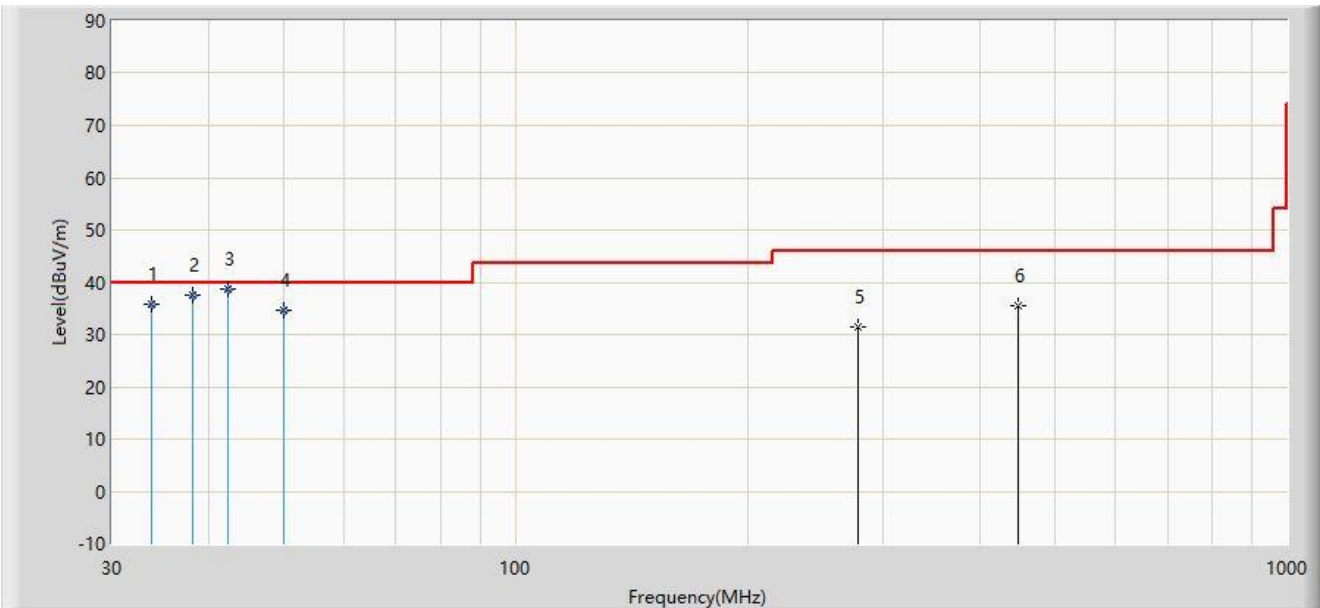

No	Mark	Frequency (MHz)	Measure Level (dBuV/m)	Reading Level (dBuV)	Margin (dB)	Limit (dBuV/m)	Factor (dB/m)	Type
1		33.790	35.767	18.240	-4.233	40.000	17.527	QP
2		38.140	37.526	19.460	-2.474	40.000	18.067	QP
3	*	42.420	38.712	20.370	-1.288	40.000	18.342	QP
4		50.040	34.603	16.370	-5.397	40.000	18.233	QP
5		278.320	31.589	13.677	-14.411	46.000	17.912	PK
6		449.040	35.391	13.149	-10.609	46.000	22.242	PK

Note 1: " * ", means this data is the worst emission level.

Note 2: Measure Level (dBuV/m) = Reading Level (dBuV) + Factor (dB/m).

Note 3: Factor (dB/m) = Cable Loss (dB) + Antenna Factor (dB/m).

Note 4: Quasi-Peak measurement was not performed when peak measure level was lower than the quasi-peak limit.

Site: WZ-AC1	Date: 2022/07/12
Temperature: 28.4°C	Humidity: 60.6%
Limit: FCC_Part15.109_RE(3m)_Class B	Engineer: Carl Jiang
Probe: VULB 9168_25-2000MHz	Polarity: Horizontal
EUT: OmniAccess Stellar	Power: AC 120V/60Hz
Test Mode 3	

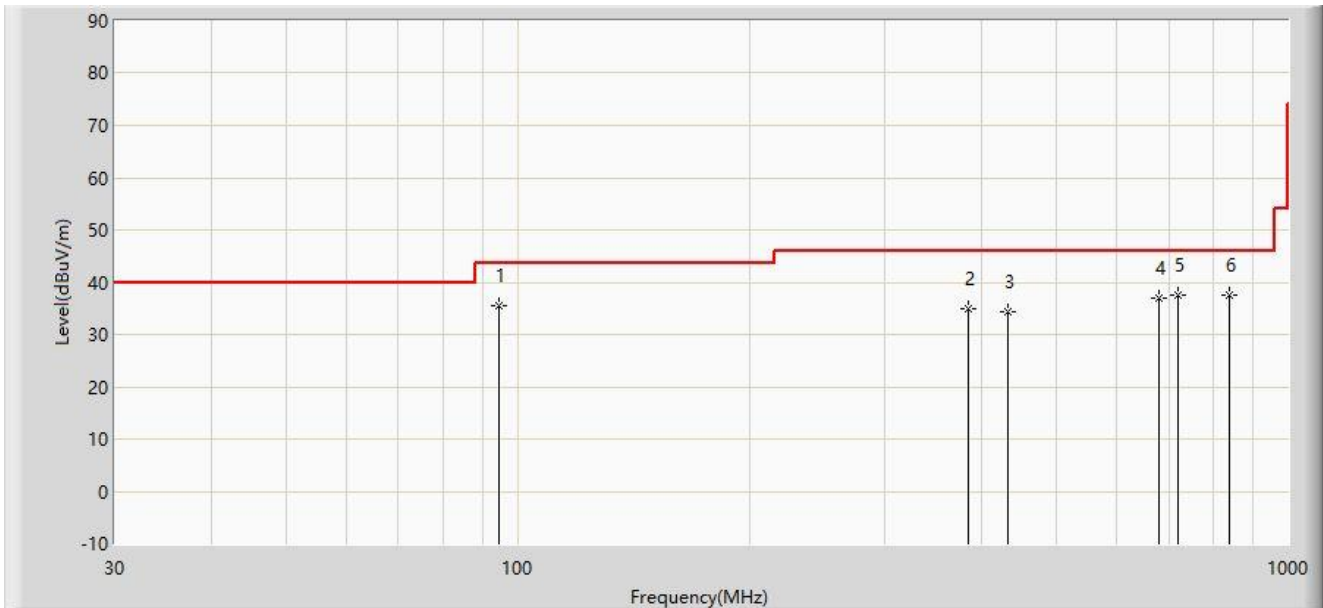

No	Mark	Frequency (MHz)	Measure Level (dBuV/m)	Reading Level (dBuV)	Margin (dB)	Limit (dBuV/m)	Factor (dB/m)	Type
1	*	94.505	35.380	22.854	-8.120	43.500	12.526	PK
2		384.050	34.852	14.399	-11.148	46.000	20.453	PK
3		433.520	34.437	12.582	-11.563	46.000	21.855	PK
4		679.900	37.048	10.864	-8.952	46.000	26.184	PK
5		720.155	37.426	10.386	-8.574	46.000	27.040	PK
6		839.950	37.674	9.004	-8.326	46.000	28.670	PK

Note 1: " * ", means this data is the worst emission level.

Note 2: Measure Level (dBuV/m) = Reading Level (dBuV) + Factor (dB/m).

Note 3: Factor (dB/m) = Cable Loss (dB) + Antenna Factor (dB/m).

Note 4: Quasi-Peak measurement was not performed when peak measure level was lower than the quasi-peak limit.

Site: WZ-AC1	Date: 2022/07/12
Temperature: 28.4°C	Humidity: 60.6%
Limit: FCC_Part15.109_RE(3m)_Class B	Engineer: Carl Jiang
Probe: VULB 9168_25-2000MHz	Polarity: Vertical
EUT: OmniAccess Stellar	Power: AC 120V/60Hz
Test Mode 3	

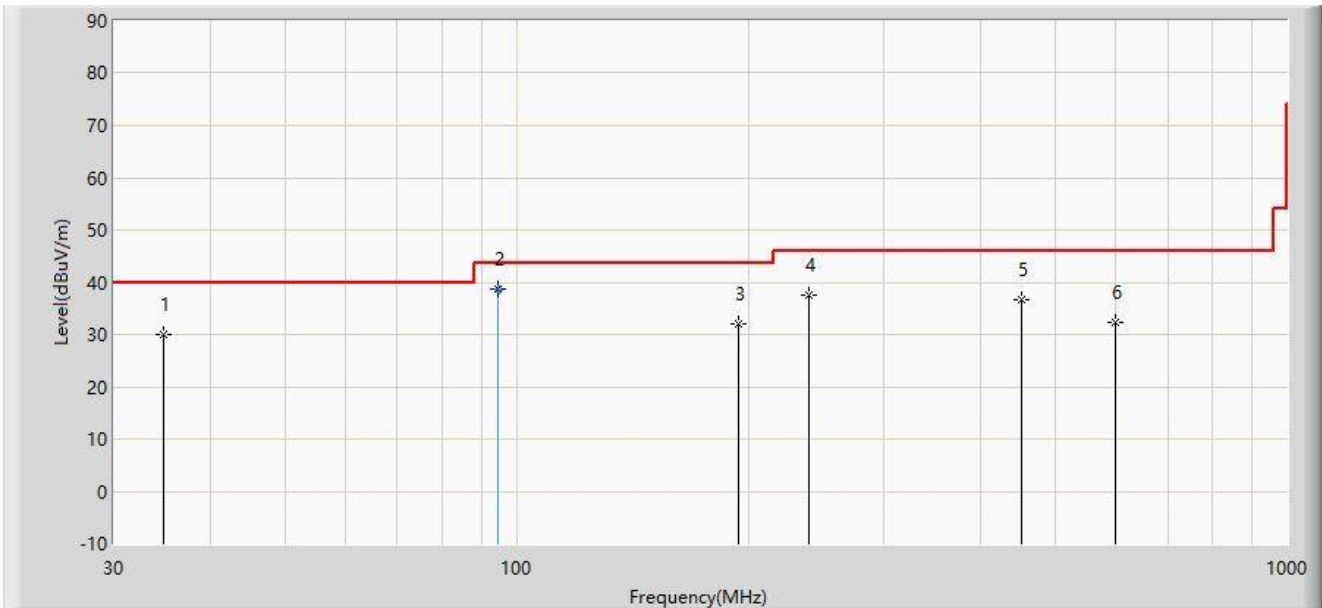

No	Mark	Frequency (MHz)	Measure Level (dBuV/m)	Reading Level (dBuV)	Margin (dB)	Limit (dBuV/m)	Factor (dB/m)	Type
1		34.850	29.976	12.309	-10.024	40.000	17.667	PK
2	*	94.700	38.758	26.210	-4.742	43.500	12.549	QP
3		193.930	32.172	17.061	-11.328	43.500	15.111	PK
4		240.005	37.491	21.334	-8.509	46.000	16.157	PK
5		451.950	36.630	14.335	-9.370	46.000	22.295	PK
6		599.875	32.265	6.806	-13.735	46.000	25.459	PK

Note 1: " * ", means this data is the worst emission level.

Note 2: Measure Level (dBuV/m) = Reading Level (dBuV) + Factor (dB/m).

Note 3: Factor (dB/m) = Cable Loss (dB) + Antenna Factor (dB/m).

Note 4: Quasi-Peak measurement was not performed when peak measure level was lower than the quasi-peak limit.

Site: WZ-AC1	Date: 2022/07/12
Temperature: 28.4°C	Humidity: 60.6%
Limit: FCC_Part15.109_RE(3m)_Class B	Engineer: Bob Zhang
Probe: BBHA9120D_1167_1-18GHz	Polarity: Horizontal
EUT: OmniAccess Stellar	Power: AC 120V/60Hz
Test Mode 1	

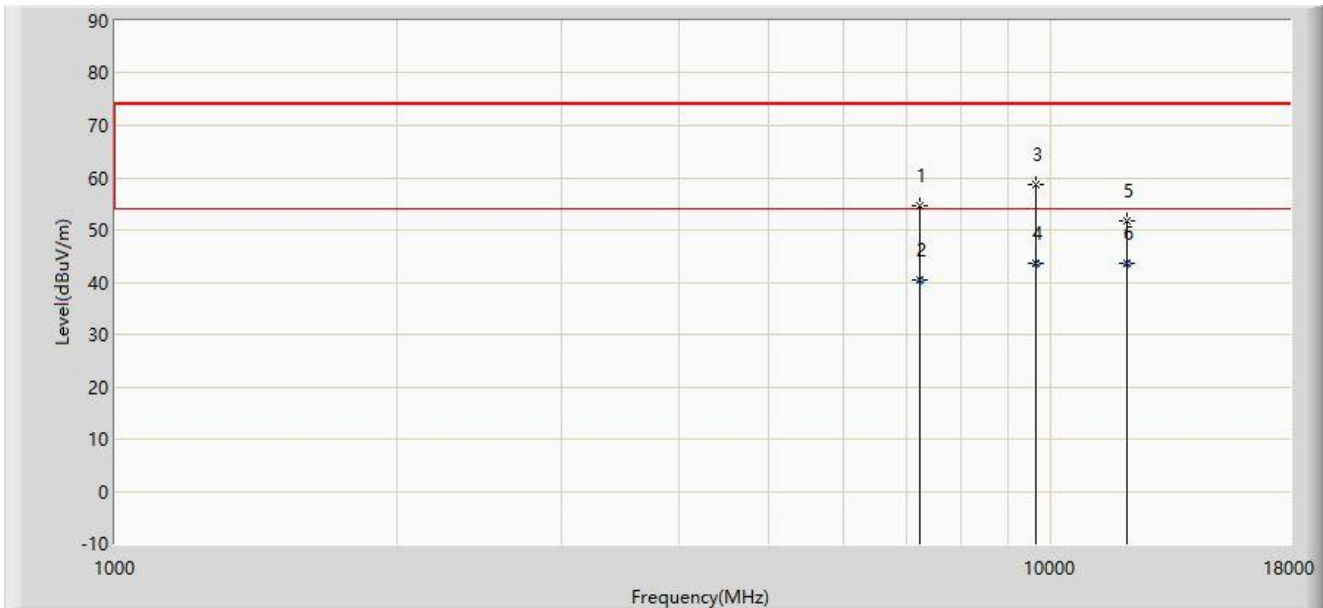

No	Mark	Frequency (MHz)	Measure Level (dB μ V/m)	Reading Level (dB μ V)	Margin (dB)	Limit (dB μ V/m)	Factor (dB/m)	Type
1		7239.000	54.629	46.593	-19.371	74.000	8.036	PK
2		7239.000	40.536	32.500	-13.464	54.000	8.036	AV
3		9644.500	58.799	46.942	-15.201	74.000	11.857	PK
4	*	9644.500	43.557	31.700	-10.443	54.000	11.857	AV
5		12058.500	51.658	39.363	-22.342	74.000	12.295	PK
6		12058.500	43.555	31.260	-10.445	54.000	12.295	AV

Note 1: " * ", means this data is the worst emission level.

Note 2: Measure Level (dB μ V/m) = Reading Level (dB μ V) + Factor (dB/m).

Note 3: Factor (dB/m) = Cable Loss (dB) + Antenna Factor (dB/m) - Pre_Amplifier Gain (dB).

Note 4: Average measurement was not performed when peak measure level was lower than the average limit.

Note 5: The amplitude of radiated emissions (frequency range from 18GHz to 36GHz) is that proximity to ambient noise, which also are attenuated more than 20 dB below the permissible value. Therefore, the data is not presented in the report.

Site: WZ-AC1	Date: 2022/07/12
Temperature: 28.4°C	Humidity: 60.6%
Limit: FCC_Part15.109_RE(3m)_Class B	Engineer: Bob Zhang
Probe: BBHA9120D_1167_1-18GHz	Polarity: Vertical
EUT: OmniAccess Stellar	Power: AC 120V/60Hz
Test Mode 1	

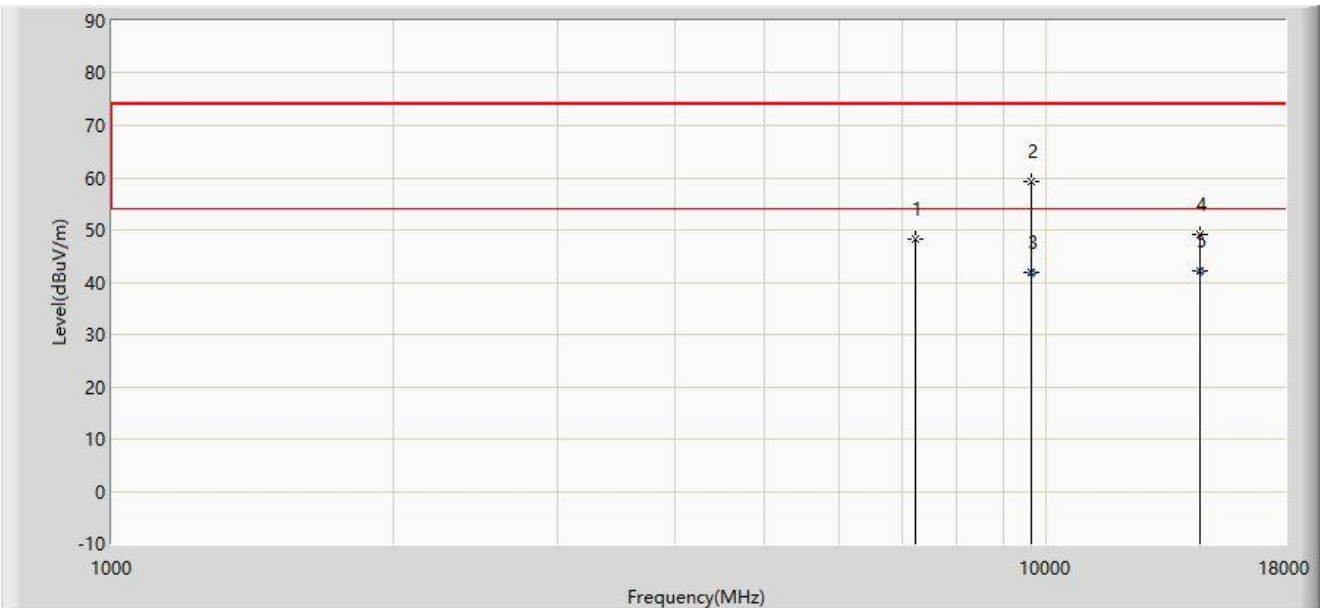

No	Mark	Frequency (MHz)	Measure Level (dB μ V/m)	Reading Level (dB μ V)	Margin (dB)	Limit (dB μ V/m)	Factor (dB/m)	Type
1		7239.000	48.349	40.313	-25.651	74.000	8.036	PK
2		9644.500	59.406	47.549	-14.594	74.000	11.857	PK
3		9644.500	41.977	30.120	-12.023	54.000	11.857	AV
4		14574.500	49.114	35.111	-24.886	74.000	14.003	PK
5	*	14574.500	42.163	28.160	-11.837	54.000	14.003	AV

Note 1: " * ", means this data is the worst emission level.

Note 2: Measure Level (dB μ V/m) = Reading Level (dB μ V) + Factor (dB/m).

Note 3: Factor (dB/m) = Cable Loss (dB) + Antenna Factor (dB/m) - Pre_Amplifier Gain (dB).

Note 4: Average measurement was not performed when peak measure level was lower than the average limit.

Note 5: The amplitude of radiated emissions (frequency range from 18GHz to 36GHz) is that proximity to ambient noise, which also are attenuated more than 20 dB below the permissible value. Therefore, the data is not presented in the report.

Site: WZ-AC1	Date: 2022/07/12
Temperature: 28.4°C	Humidity: 60.6%
Limit: FCC_Part15.109_RE(3m)_Class B	Engineer: Bob Zhang
Probe: BBHA9120D_1167_1-18GHz	Polarity: Horizontal
EUT: OmniAccess Stellar	Power: By PoE
Test Mode 2	

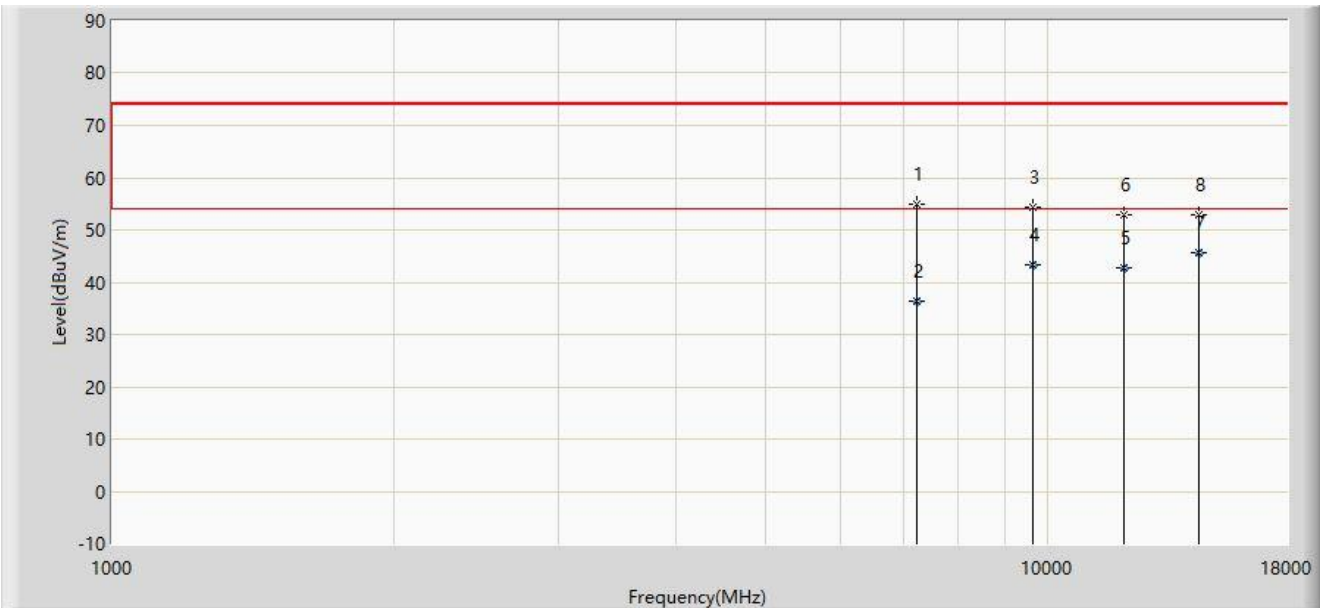

No	Mark	Frequency (MHz)	Measure Level (dB μ V/m)	Reading Level (dB μ V)	Margin (dB)	Limit (dB μ V/m)	Factor (dB/m)	Type
1		7239.000	54.814	46.778	-19.186	74.000	8.036	PK
2		7239.000	36.496	28.460	-17.504	54.000	8.036	AV
3		9644.500	54.405	42.548	-19.595	74.000	11.857	PK
4		9644.500	43.397	31.540	-10.603	54.000	11.857	AV
5		12058.000	42.797	30.500	-11.203	54.000	12.297	AV
6		12058.500	52.888	40.593	-21.112	74.000	12.295	PK
7	*	14472.000	45.594	31.230	-8.406	54.000	14.365	AV
8		14472.500	52.864	38.492	-21.136	74.000	14.372	PK

Note 1: " * ", means this data is the worst emission level.

Note 2: Measure Level (dB μ V/m) = Reading Level (dB μ V) + Factor (dB/m).

Note 3: Factor (dB/m) = Cable Loss (dB) + Antenna Factor (dB/m) - Pre_Amplifier Gain (dB).

Note 4: Average measurement was not performed when peak measure level was lower than the average limit.

Note 5: The amplitude of radiated emissions (frequency range from 18GHz to 36GHz) is that proximity to ambient noise, which also are attenuated more than 20 dB below the permissible value. Therefore, the data is not presented in the report.

Site: WZ-AC1	Date: 2022/07/12
Temperature: 28.4°C	Humidity: 60.6%
Limit: FCC_Part15.109_RE(3m)_Class B	Engineer: Bob Zhang
Probe: BBHA9120D_1167_1-18GHz	Polarity: Vertical
EUT: OmniAccess Stellar	Power: By PoE
Test Mode 2	

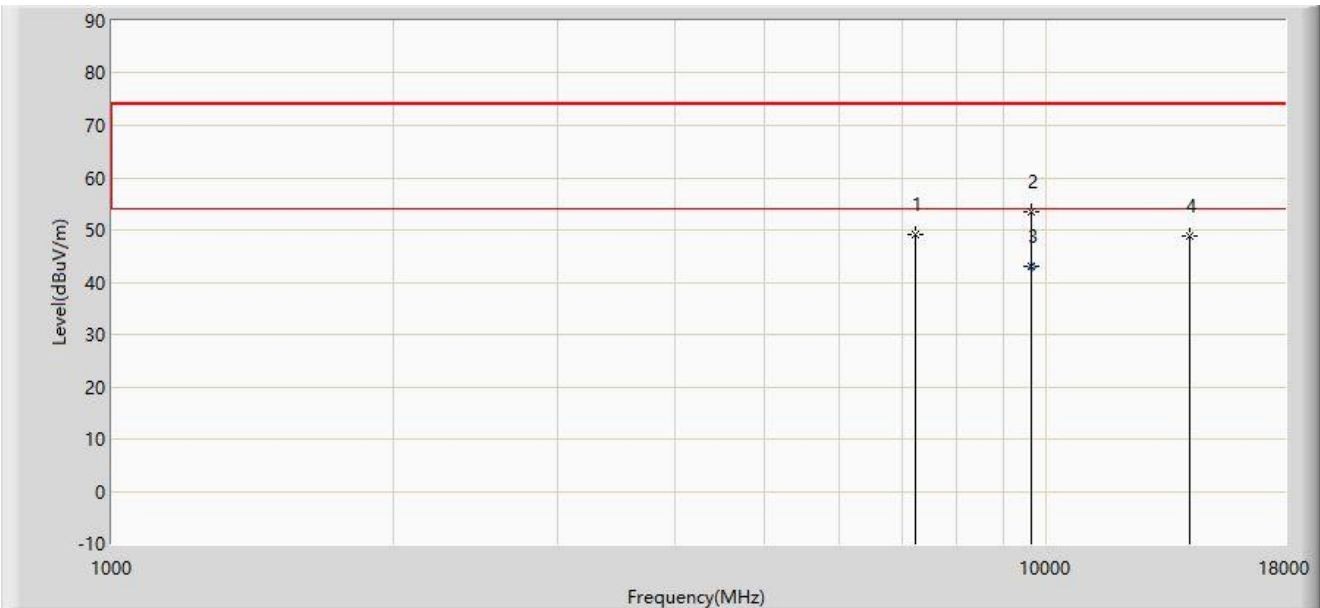

No	Mark	Frequency (MHz)	Measure Level (dBμV/m)	Reading Level (dBμV)	Margin (dB)	Limit (dBμV/m)	Factor (dB/m)	Type
1		7230.500	49.091	40.959	-24.909	74.000	8.132	PK
2		9644.500	53.440	41.583	-20.560	74.000	11.857	PK
3	*	9644.500	43.117	31.260	-10.883	54.000	11.857	AV
4		14251.500	48.714	34.659	-25.286	74.000	14.055	PK

Note 1: " * ", means this data is the worst emission level.

Note 2: Measure Level (dBμV/m) = Reading Level (dBμV) + Factor (dB/m).

Note 3: Factor (dB/m) = Cable Loss (dB) + Antenna Factor (dB/m) - Pre_Amplifier Gain (dB).

Note 4: Average measurement was not performed when peak measure level was lower than the average limit.

Note 5: The amplitude of radiated emissions (frequency range from 18GHz to 36GHz) is that proximity to ambient noise, which also are attenuated more than 20 dB below the permissible value. Therefore, the data is not presented in the report.

Site: WZ-AC1	Date: 2022/07/12
Temperature: 28.4°C	Humidity: 60.6%
Limit: FCC_Part15.109_RE(3m)_Class B	Engineer: Carl Jiang
Probe: BBHA9120D_1167_1-18GHz	Polarity: Horizontal
EUT: OmniAccess Stellar	Power: AC 120V/60Hz
Test Mode 3	

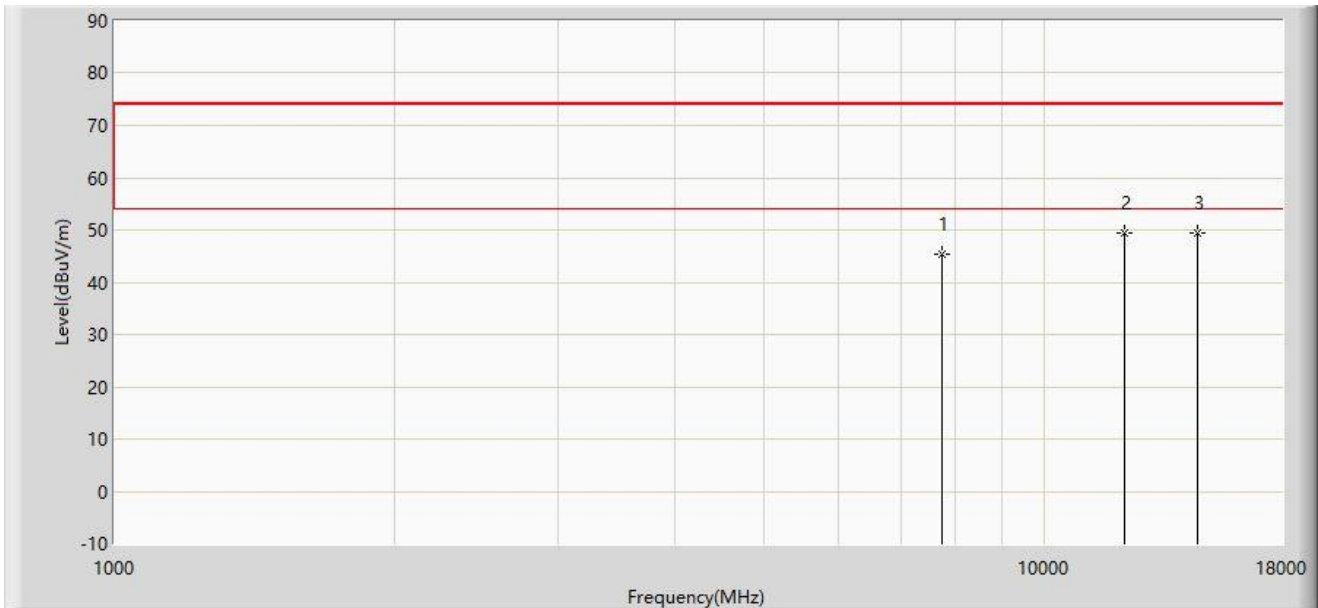

No	Mark	Frequency (MHz)	Measure Level (dB μ V/m)	Reading Level (dB μ V)	Margin (dB)	Limit (dB μ V/m)	Factor (dB/m)	Type
1		7749.000	45.439	37.468	-28.561	74.000	7.971	PK
2		12186.000	49.494	37.436	-24.506	74.000	12.058	PK
3	*	14591.500	49.526	35.240	-24.474	74.000	14.286	PK

Note 1: " * ", means this data is the worst emission level.

Note 2: Measure Level (dB μ V/m) = Reading Level (dB μ V) + Factor (dB/m).

Note 3: Factor (dB/m) = Cable Loss (dB) + Antenna Factor (dB/m) - Pre_Amplifier Gain (dB).

Note 4: Average measurement was not performed when peak measure level was lower than the average limit.

Note 5: The amplitude of radiated emissions (frequency range from 18GHz to 36GHz) is that proximity to ambient noise, which also are attenuated more than 20 dB below the permissible value. Therefore, the data is not presented in the report.

Site: WZ-AC1	Date: 2022/07/12
Temperature: 28.4°C	Humidity: 60.6%
Limit: FCC_Part15.109_RE(3m)_Class B	Engineer: Carl Jiang
Probe: BBHA9120D_1167_1-18GHz	Polarity: Vertical
EUT: OmniAccess Stellar	Power: AC 120V/60Hz
Test Mode 3	

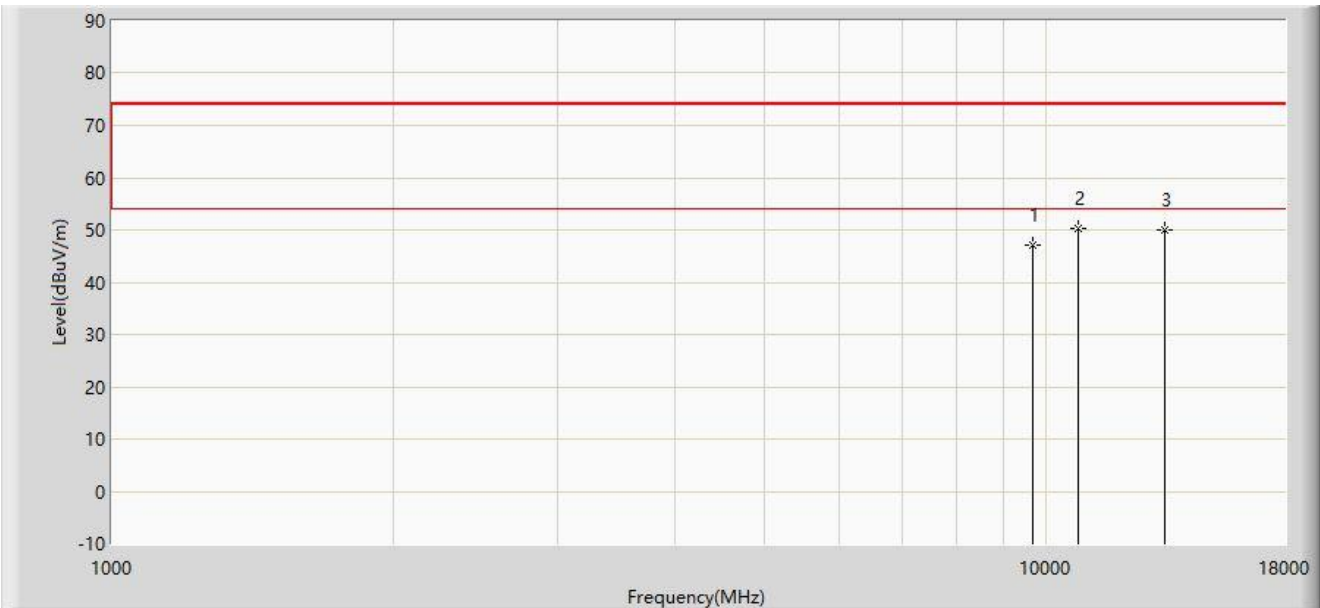

No	Mark	Frequency (MHz)	Measure Level (dBμV/m)	Reading Level (dBμV)	Margin (dB)	Limit (dBμV/m)	Factor (dB/m)	Type
1		9653.000	47.186	35.267	-26.814	74.000	11.919	PK
2	*	10826.000	50.250	37.485	-23.750	74.000	12.765	PK
3		13393.000	49.867	36.552	-24.133	74.000	13.315	PK

Note 1: " * ", means this data is the worst emission level.

Note 2: Measure Level (dBμV/m) = Reading Level (dBμV) + Factor (dB/m).

Note 3: Factor (dB/m) = Cable Loss (dB) + Antenna Factor (dB/m) - Pre_Amplifier Gain (dB).

Note 4: Average measurement was not performed when peak measure level was lower than the average limit.

Note 5: The amplitude of radiated emissions (frequency range from 18GHz to 36GHz) is that proximity to ambient noise, which also are attenuated more than 20 dB below the permissible value. Therefore, the data is not presented in the report.

Appendix A - Test Setup Photograph

Refer to "2203RSU064-UT" file.

Appendix B - EUT Photograph

Refer to "2203RSU064-UE" file.

The End