



FCC TEST REPORT

Page 1 of 23

LAB LOCATION:
DATE IN:

DONG GUAN, CHINA
July. 06, 2016

REPORT NUMBER:
DATE OUT:

63116-070284
July. 22, 2016

Product Description : Bluetooth Wireless Headphone

Style No. : 4449935/4425299; 4449943/4425257/44435611/4416165

P.O/Order No. : /

FCC ID : 2A188-4449935

Applicant's name : Ocean International Company
Address : No.39 the Second Industrial Rd, Tang Xia Yong Town,
Song Gang Street, Bao An District, Shen Zhen City,
Guang Dong Province, China 518105

Manufacturer : Ocean International Company
Address : No.39 the Second Industrial Rd, Tang Xia Yong Town,
Song Gang Street, Bao An District, Shen Zhen City,
Guang Dong Province, China 518105

Laboratory Name : Modern Testing Services (Dongguan) Limited
Address : No.76, Liang Ping Road, Xin Jiu Wei Village, Liaobu,
Town Dongguan City, Guangdong Province, China
Tel: (86)769-81120818
Fax: (86)769-81120815

Report No. : 63116-070284

TEST RESULT CERTIFICATION

Applicant's name : Ocean International Company
Address : No.39 the Second Industrial Rd, Tang Xia Yong Town,
Song Gang Street, Bao An District, Shen Zhen City,
Guang Dong Province, China 518105

Product description

Trade Mark: /
Product name..... : Bluetooth Wireless Headphone
Style No. : 4449935/4425299; 4449943/4425257/44435611/4416165
Standards : FCC Rules and Regulations Part 15 Subpart C Section 15.249
ANSI C63.10: 2013

This publication may be reproduced in whole or in part for non-commercial purposes as long as the Modern Testing Services (Dongguan) Limited is acknowledged as copyright owner and source of the material. Modern Testing Services (Dongguan) Limited takes no responsibility for and will not assume liability for damages resulting from the reader's interpretation of the reproduced material due to its placement and context.

Date of Test :
Date (s) of performance of tests..... : **July. 06, 2016 ~ July. 22, 2016**
Date of Issue..... : **July. 22, 2016**
Test Result..... : **Pass**

Prepared by:



JANG Ping, Loken
Project Engineer

Reviewed by:



WANG Yang, Oscar
Project Supervisor

Approved by:



CHEN Chu Peng, Ken
EMC Manager

Table of Contents	Page
1 . TEST SUMMARY	4
2 . GENERAL INFORMATION	5
2.1 General Description of EUT	5
2.2 Operation of EUT during testing	6
2.3 Description of Test Setup	6
2.4 Measurement Instruments List	7
3 . CONDUCTED EMISSION TEST	9
3.1 Block Diagram of Test Setup	9
3.2 Conducted Power Line Emission Limit	9
3.3 Test Procedure	9
3.4 Test Result	9
4 . RADIATED EMISSION TEST	11
4.1 Block Diagram of Test Setup	11
4.2 Limits	12
4.3 Test Procedure	12
4.4 Test Result	12
5 . BAND EDGE	15
5.1 Block Diagram of Test Setup	15
5.2 Limits	15
5.3 Test Procedure	15
5.4 Test Result	15
6. OCCUPIED BANDWIDTH MEASUREMENT	18
6.1 Block Diagram of Test Setup	18
6.2 Test Procedure	18
6.3 Test Result	18
7. ANTENNA REQUIREMENT	21
8. PHOTOGRAPH OF TEST	22

1. TEST SUMMARY

1.1 Description of Test

Description of Test	Result
CONDUCTED EMISSIONS TEST	Compliant
RADIATED EMISSION TEST	Compliant
BAND EDGE	Compliant
OCCUPIED BANDWIDTH MEASUREMENT	Compliant
ANTENNA REQUIREMENT	Compliant

1.2 Test Location

Test Firm : Dongguan Dongdian Testing Service Co., Ltd
Address : No.17 Zongbu road 2, Songshan Lake Sci&Tech, DongGuan
City, Guangdong province,523808 China
FCC Registration Number: 270092

1.3 Measurement Uncertainty

Measurement Uncertainty

Conducted Emission Expanded Uncertainty = 2.23dB, k=2
Radiated emission expanded uncertainty(9kHz-30MHz) = 3.08dB, k=2
Radiated emission expanded uncertainty(30MHz-1000MHz) = 4.42dB, k=2
Radiated emission expanded uncertainty(Above 1GHz) = 4.06dB, k=2

2. GENERAL INFORMATION

2.1 General Description of EUT

EUT	:	Bluetooth Wireless Headphone
Style No.	:	4449935/4425299; 4449943/4425257/44435611/4416165
P.O/Order No.	:	/
FCC ID	:	2A188-4449935
Model Difference	:	N/A
Modulation Type	:	GFSK
Antenna Type	:	Internal
Antenna Gain	:	0 dBi
Operation frequency	:	2402-2480MHz
Number of Channels	:	40
Data Rate	:	/

Carrier Frequency of Channels

Channel No.	Frequency (MHz)	Channel No.	Frequency (MHz)	Channel No.	Frequency (MHz)	Channel No.	Frequency (MHz)
0	2402	1	2404	2	2406	3	2408
4	2410	5	2412	6	2414	7	2416
8	2418	9	2420	10	2422	11	2424
12	2426	13	2428	14	2430	15	2432
16	2434	17	2436	18	2438	19	2440
20	2442	21	2444	22	2446	23	2448
24	2450	25	2452	26	2454	27	2456
28	2458	29	2460	30	2462	31	2464
32	2466	33	2468	34	2470	35	2472
36	2474	37	2476	38	2478	39	2480

2.2 Operation of EUT during testing

Operating Mode

The mode is used: **Transmitting mode**

Low Channel: 2402MHz

Middle Channel: 2440MHz

High Channel: 2480MHz

2.3 Description of Test Setup

Operation of EUT during testing



2.4 Measurement Instruments List

Item	Equipment	Manufacturer	Model No.	Serial No.	Last Cal.	Cal. Interval
1.	EMI Receiver	Rohde & Schwarz	ESCI	100627	Feb. 19, 2016	1 Year
2.	LISN	SchwarzBeck	NSLK 8126	8126377	Feb. 19, 2016	1 Year
3.	RF Switching Unit	Compliance Direction	RSU-M2	38303	Feb. 19, 2016	1 Year
4.	EMI Test Software ES-K1	Rohde & Schwarz	N/A	N/A	N/A	N/A
5.	EMI Test Receiver	Rohde & Schwarz	ESCI	100627	Feb. 19, 2016	1 Year
6.	Trilog Broadband Antenna	Schwarzbeck	VULB9163	VULB 9163-289	Feb. 19, 2016	1 Year
7.	Pre-amplifier	Compliance Direction	PAP-0203	22008	Feb. 19, 2016	1 Year
8.	EMI Test Software EZ-EMC	SHURPLE	N/A	N/A	N/A	N/A
9.	EMI Receiver	Rohde & Schwarz	ESCI	100627	Feb. 19, 2016	1 Year
10.	LISN	SchwarzBeck	NSLK 8126	8126377	Feb. 19, 2016	1 Year
11.	RF Switching Unit	Compliance Direction	RSU-M2	38303	Feb. 19, 2016	1 Year
12.	EMI Test Software ES-K1	Rohde & Schwarz	N/A	N/A	N/A	N/A
13.	EMI Receiver	Rohde & Schwarz	ESCI	100627	Feb. 19, 2016	1 Year
14.	EMI Receiver	Rohde & Schwarz	ESCI	100627	Feb. 19, 2016	1 Year
15.	LISN	SchwarzBeck	NSLK 8126	8126377	Feb. 19, 2016	1 Year
16.	RF Switching Unit	Compliance Direction	RSU-M2	38303	Feb. 19, 2016	1 Year
17.	EMI Test Software ES-K1	Rohde & Schwarz	N/A	N/A	N/A	N/A
18.	Programmable AC Power source	SOPH POWER	PAG-1050	630250	Feb. 19, 2016	1 Year
19.	Harmonic and Flicker Analyzer	LAPLACE	AC2000A	272629	Feb. 19, 2016	1 Year
20.	Harmonic and Flicker Test Software AC 2000A	LAPLACE	N/A	N/A	N/A	N/A
21.	ESD Simulators	KIKUSUI	KES4021	LJ003477	Feb. 19, 2016	1 Year
22.	EFT Generator	EMPEK	EFT-4040B	0430928N	Feb. 19, 2016	1 Year
23.	Shielding Room	ChangZhou ZhongYu	JB88	SEL0166	Feb. 19, 2016	1 Year
24.	Signal Generator 9KHz~2.2GHz	R&S	SML02	SEL0143	Feb. 19, 2016	1 Year
25.	Signal Generator 9KHz~1.1GHz	R&S	SML01	SEL0135	Feb. 19, 2016	1 Year
26.	Power Meter	R&S	NRVS	SEL0144	Feb. 19, 2016	1 Year
27.	RF Level Meter		URV35	SEL0137	Feb. 19, 2016	1 Year
28.	Audio Analyzer	R&S	UPL	SEL0136	Feb. 19, 2016	1 Year
29.	RF-Amplifier 150KHz~150MHz	BONN Elektronik	BSA1515-25	SEL0157	Feb. 19, 2016	1 Year
30.	Stripline Test Cell	Erika Fiedler	VDE0872	SEL0167	N/A	N/A
31.	TV Test Transmitter	R&S	SFM	SEL0159	Feb. 19, 2016	1 Year
32.	TV Generator PAL	R&S	SGPF	SEL0138	Feb. 19, 2016	1 Year
33.	TV Generator Ntsc	R&S	SGMF	SEL0140	Feb. 19, 2016	1 Year
34.	TV Generator Secam	R&S	SGSF	SEL0139	Feb. 19, 2016	1 Year

35.	TV Test Transmitter 0.3MHz~3300MHz	R&S	SFQ	SEL0142	Feb. 19, 2016	1 Year
36.	MPEG2 Measurement Generator	R&S	DVG	SEL0141	Feb. 19, 2016	1 Year
37.	Spectrum Analyzer	R&S	FSP	SEL0177	Feb. 19, 2016	1 Year
38.	Matching	R&S	RAM	SEL0146	N/A	N/A
39.	Matching	R&S	RAM	SEL0148	N/A	N/A
40.	Absorbing Clamp	R&S	MDS21	SEL0158	Feb. 19, 2016	1 Year
41.	Coupling Set	Erika Fiedler	Rco, Rci, MC, AC, LC	SEL0149	N/A	N/A
42.	Filters	Erika Fiedler	Sr, LBS	SEL0150	N/A	N/A
43.	Matching Network	Erika Fiedler	MN, T1	SEL0151	N/A	N/A
44.	Fully Anechoic Room	ChangZhou ZhongYu	854	SEL0169	Oct. 24, 2015	1 Year
45.	Signal Generator	R&S	SML03	SEL0068	Oct. 24, 2015	1 Year
46.	RF-Amplifier 30M~1GHz	Amplifier Reasearch	250W1000A	SEL0066	Oct. 24, 2015	1 Year
47.	RF-Amplifier 0.8~3.0GHz	Amplifier Reasearch	60S1G3	SEL0065	Oct. 24, 2015	1 Year
48.	Power Meter	R&S	NRVD	SEL0069	Oct. 24, 2015	1 Year
49.	Power Sensor	R&S	URV5-Z2	SEL0071	Oct. 24, 2015	1 Year
50.	Power Sensor	R&S	URV5-Z2	SEL0072	Oct. 24, 2015	1 Year
51.	Software EMC32	R&S	EMC32-S	SEL0082	N/A	N/A
52.	Log-periodic Antenna	Amplifier Reasearch	AT1080	SEL0073	N/A	N/A
53.	Antenna Tripod	Amplifier Reasearch	TP1000A	SEL0074	N/A	N/A
54.	High Gain Horn Antenna(0.8-5GHz)	Amplifier Reasearch	AT4002A	SEL0075	N/A	N/A
55.	Double-Ridged Waveguide Horn Antenna (0.8-18GHz)	ROHDE& SCHWARZ	HF907	100013	Oct. 24, 2015	1 Year
56.	Log-periodic Antenna (850MHz-26.5GHz)	ROHDE& SCHWARZ	HL050S7	100496	Oct. 24, 2015	1 Year

3. CONDUCTED EMISSION TEST

3.1 Block Diagram of Test Setup

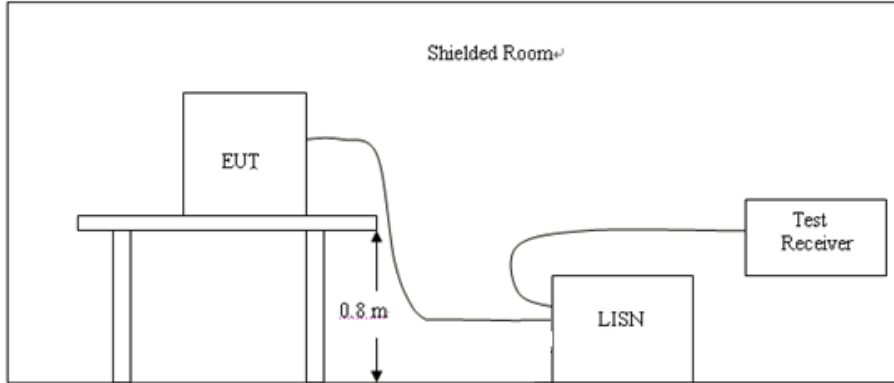

3.2 Conducted Power Line Emission Limit

For unintentional device, according to § 15.107(a) Line Conducted Emission Limits is as following

Frequency (MHz)	Maximum RF Line Voltage (dBµV)			
	CLASS A		CLASS B	
	Q.P.	Ave.	Q.P.	Ave.
0.15 - 0.50	79	66	66-56*	56-46*
0.50 - 5.00	73	60	56	46
5.00 - 30.0	73	60	60	50

* Decreasing linearly with the logarithm of the frequency

For intentional device, according to §15.207(a) Line Conducted Emission Limit is same as above table.

3.3 Test Procedure

- 1, The equipment was set up as per the test configuration to simulate typical actual usage per the user's manual. The EUT is a tabletop system, a wooden table with a height of 0.8 meters is used and is placed on the ground plane as per ANSI C63.10.
- 2, Support equipment, if needed, was placed as per ANSI C63.10.
- 3, All I/O cables were positioned to simulate typical actual usage as per ANSI C6310.
- 4, If a EUT received DC power from the USB Port of Notebook PC, the PC's adapter received AC 120V/60Hz power through a Line Impedance Stabilization Network (LISN) which supplied power source and was grounded to the ground plane.
- 5, All support equipments received AC power from a second LISN, if any.
- 6, The EUT test program was started. Emissions were measured on each current carrying line of the EUT using a spectrum Analyzer / Receiver connected to the LISN powering the EUT. The LISN has two monitoring points: Line 1 (Hot Side) and Line 2 (Neutral Side). Two scans were taken: one with Line 1 connected to Analyzer / Receiver and Line 2 connected to a 50 ohm load; the second scan had Line 1 connected to a 50 ohm load and Line 2 connected to the Analyzer / Receiver.
- 7, Analyzer / Receiver scanned from 150 KHz to 30MHz for emissions in each of the test modes

3.4 Test Result

Pass

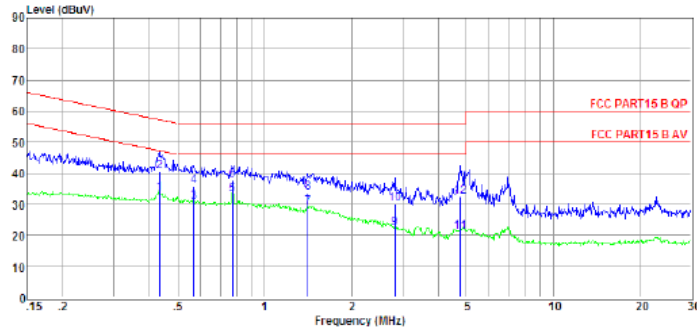

Item (Mark)	Freq (MHz)	Read Level (dBuV)	LISN Factor (dB)	Cable Loss (dB)	Pulse Limiter Factor (dB)	Result Level (dBuV)	Limit Line (dBuV)	Over Limit (dB)	Detector	Phase
1	0.43	13.79	9.61	0.02	9.86	33.28	47.20	-13.92	Average	LINE
2	0.43	21.13	9.61	0.02	9.86	40.62	57.20	-16.58	QP	LINE
3	0.57	11.03	9.61	0.03	9.86	30.53	46.00	-15.47	Average	LINE
4	0.57	16.24	9.61	0.03	9.86	35.74	56.00	-20.26	QP	LINE
5	0.78	13.74	9.61	0.03	9.86	33.24	46.00	-12.76	Average	LINE
6	0.78	18.22	9.61	0.03	9.86	37.72	56.00	-18.28	QP	LINE
7	1.41	9.48	9.62	0.03	9.86	28.99	46.00	-17.01	Average	LINE
8	1.41	14.31	9.62	0.03	9.86	33.82	56.00	-22.18	QP	LINE
9	2.82	2.77	9.64	0.05	9.87	22.33	46.00	-23.67	Average	LINE
10	2.82	10.52	9.64	0.05	9.87	30.08	56.00	-25.92	QP	LINE
11	4.75	1.53	9.66	0.07	9.88	21.14	46.00	-24.86	Average	LINE
12	4.75	12.79	9.66	0.07	9.88	32.40	56.00	-23.60	QP	LINE

Note: 1. Result Level = Read Level + LISN Factor + Pulse Limiter Factor + Cable loss.
 2. If QP Result complies with AV limit, AV Result is deemed to comply with AV limit.
 3. Test setup: RBW: 200 Hz (9 kHz—150 kHz), 9 kHz (150 kHz—30 MHz).
 4. Step size: 80Hz (0.009MHz-0.15MHz), 4 kHz (0.15MHz-30MHz), Scan time: auto.

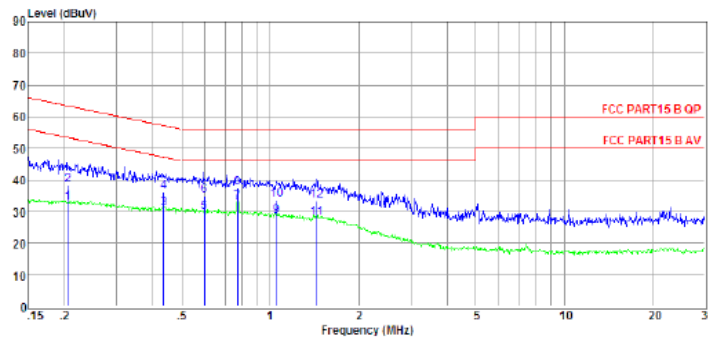

Item (Mark)	Freq (MHz)	Read Level (dBuV)	LISN Factor (dB)	Cable Loss (dB)	Pulse Limiter Factor (dB)	Result Level (dBuV)	Limit Line (dBuV)	Over Limit (dB)	Detector	Phase
1	0.21	13.28	9.61	0.02	9.86	32.77	53.40	-20.63	Average	NEUTRAL
2	0.21	18.78	9.61	0.02	9.86	38.27	63.40	-25.13	QP	NEUTRAL
3	0.44	11.48	9.61	0.02	9.86	30.97	47.15	-16.18	Average	NEUTRAL
4	0.44	16.79	9.61	0.02	9.86	36.28	57.15	-20.87	QP	NEUTRAL
5	0.60	10.31	9.61	0.03	9.86	29.81	46.00	-16.19	Average	NEUTRAL
6	0.60	15.31	9.61	0.03	9.86	34.81	56.00	-21.19	QP	NEUTRAL
7	0.78	13.41	9.61	0.03	9.86	32.91	46.00	-13.09	Average	NEUTRAL
8	0.78	17.81	9.61	0.03	9.86	37.31	56.00	-18.69	QP	NEUTRAL
9	1.05	9.00	9.61	0.03	9.86	28.50	46.00	-17.50	Average	NEUTRAL
10	1.05	14.08	9.61	0.03	9.86	33.58	56.00	-22.42	QP	NEUTRAL
11	1.44	8.47	9.62	0.03	9.86	27.98	46.00	-18.02	Average	NEUTRAL
12	1.44	13.78	9.62	0.03	9.86	33.29	56.00	-22.71	QP	NEUTRAL

Note: 1. Result Level = Read Level + LISN Factor + Pulse Limiter Factor + Cable loss.
 2. If QP Result complies with AV limit, AV Result is deemed to comply with AV limit.
 3. Test setup: RBW: 200 Hz (9 kHz—150 kHz), 9 kHz (150 kHz—30 MHz).
 4. Step size: 80Hz (0.009MHz-0.15MHz), 4 kHz (0.15MHz-30MHz), Scan time: auto.

4. RADIATED EMISSION TEST

4.1 Block Diagram of Test Setup

(1) Radiated Emission Test-Up Frequency Below 30MHz

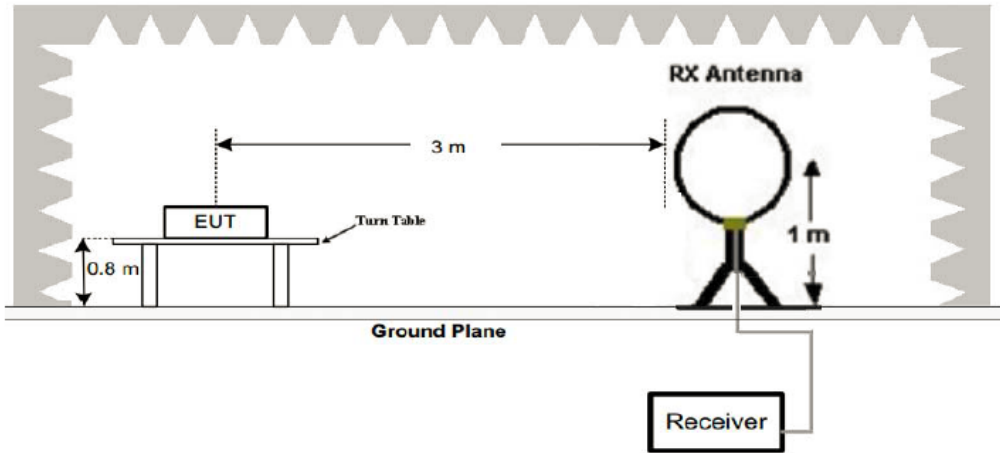

(2) Radiated Emission Test-Up Frequency 30MHz~1GHz

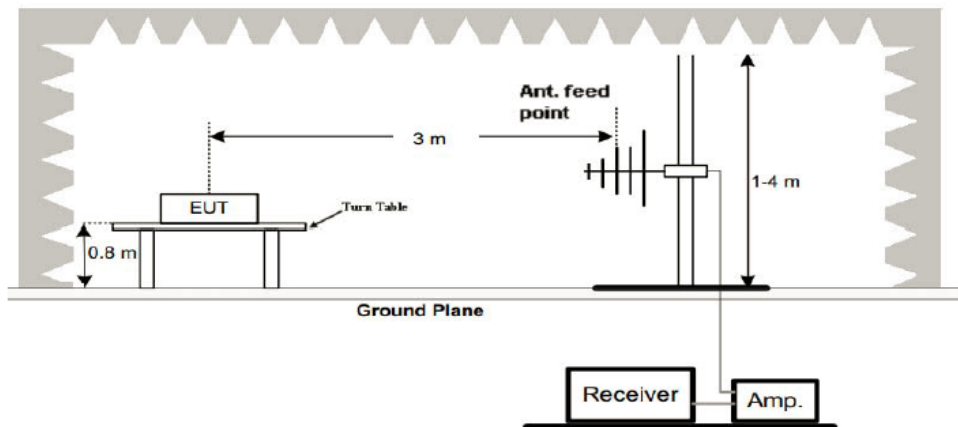

(3) Radiated Emission Test-Up Frequency Above 1GHz

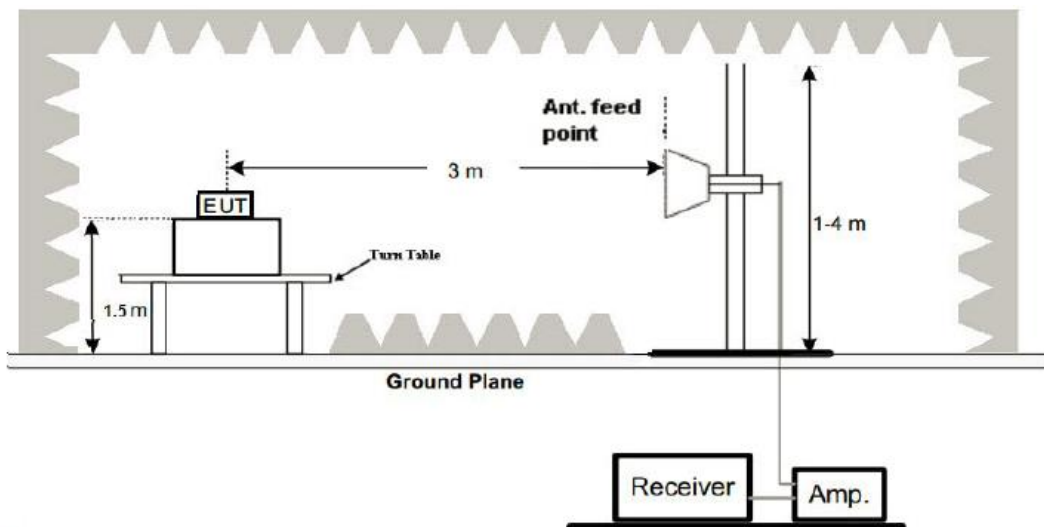

4.2 Limits

For unintentional device, according to § 15.109(a), except for Class A digital devices, the field strength of radiated emissions from unintentional radiators at a distance of 3 meters shall not exceed the following values:

Frequency range MHz	Distance Meters	Field Strengths Limit (15.209) μV/m	
0.009 ~ 0.490	300	2400/F(kHz)	
0.490 ~ 1.705	30	24000/F(kHz)	
1.705 ~ 30	30	30	
30 ~ 88	3	100	
88 ~ 216	3	150	
216 ~ 960	3	200	
Above 960	3	500	
Frequency range MHz	Distance Meters	Field Strengths Limit (15.249)	
		μV/m (Field strength of fundamental)	μV/m (Field strength of Harmonics)
902 ~ 928	3	50	500
2400 ~ 2483.5	3	50	500
5725 ~ 5875	3	50	500
24000 ~ 2425000	3	250	2500

For intentional device, according to § 15.209(a), the general requirement of field strength of radiated emissions from intentional radiators at a distance of 3 meters shall not exceed the above table.

4.3 Test Procedure

1. Below 1GHz measurement the EUT is placed on turntable which is 0.8m above ground plane. And above 1GHz measurement EUT was placed on low permittivity and low tangent turn table which is 1.5m above ground plane..
2. The turntable shall be rotated for 360 degrees to determine the position of maximum emission level.
3. EUT is set 3m away from the receiving antenna, which is varied from 1m to 4m to find out the highest emissions.
4. Maximum procedure was performed on the six highest emissions to ensure EUT compliance.
5. And also, each emission was to be maximized by changing the polarization of receiving antenna both horizontal and vertical.
6. Repeat above procedures until the measurements for all frequencies are complete.

Note:

For battery operated equipment, the equipment tests shall be performed using a new battery.

4.4 Test Result PASS

All the test modes completed for test. The worst case of Radiated Emission Is transmitter CH 2402; the test data of this mode was reported.

Below 1GHz Test Results:

Antenna: Ver.

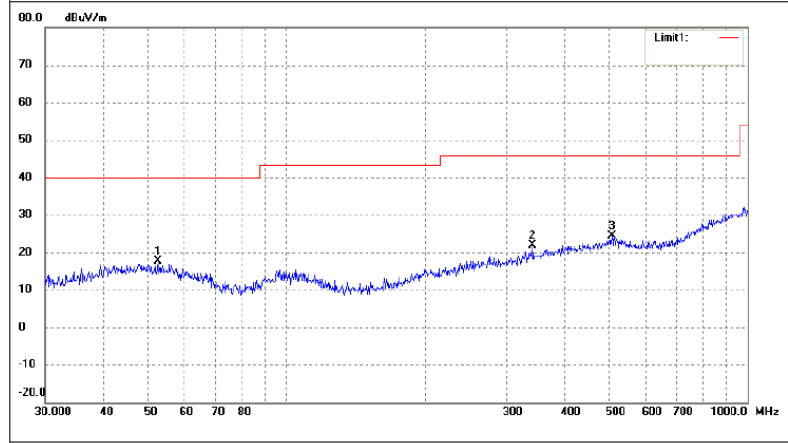

No.	Frequency (MHz)	Reading (dBuV/m)	Correct (dB/m)	Result (dBuV/m)	Limit (dBuV/m)	Margin (dB)	Degree (°)	Height (cm)	Remark
1	52.5753	25.41	-7.71	17.70	40.00	-22.30	264	100	peak
2	341.9787	26.41	-4.44	21.97	46.00	-24.03	113	200	peak
3*	508.2582	25.43	-1.17	24.26	46.00	-21.74	287	100	peak

Antenna: Hor.

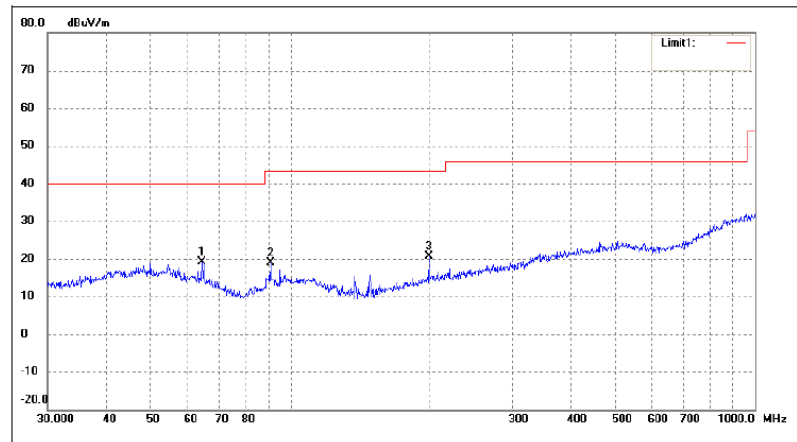

No.	Frequency (MHz)	Reading (dBuV/m)	Correct (dB/m)	Result (dBuV/m)	Limit (dBuV/m)	Margin (dB)	Degree (°)	Height (cm)	Remark
1	64.4331	28.76	-9.75	19.01	40.00	-20.99	234	100	peak
2	90.5374	29.94	-11.07	18.87	43.50	-24.63	118	100	QP
3	198.5880	29.72	-9.20	20.52	43.50	-22.98	164	100	QP

Remark:

- (1) Measuring frequencies from 9 KHz to the 1 GHz, Radiated emission test from 9KHz to 30MHz was verified, and no any emission was found except system noise floor.
- (2) * denotes emission frequency which appearing within the Restricted Bands specified in provision of 15.205, then the general radiated emission limits in 15.209 apply.
- (3) The IF bandwidth of EMI Test Receiver between 30MHz to 1GHz was 120KHz, 1 MHz for measuring above 1 GHz, below 30MHz was 10KHz.

Above 1 GHz Test Results:

Frequency (MHz)	Reading (dBuV/m)	Correct dB/m	Result (dBuV/m)	Limit (dBuV/m)	Margin (dB)	Polar H/V	Detector
2402	80.55	-3.46	77.09	114	-36.91	H	PK
2402	69.15	-3.46	65.69	94	-28.31	H	AV
4804	42.45	0.60	43.05	74	-30.95	H	PK
4804	32.77	0.60	33.37	54	-20.63	H	AV
7206	34.84	3.72	38.56	74	-35.44	H	PK
7206	26.07	3.82	29.89	54	-24.11	H	AV
2402	83.96	-3.46	80.50	114	-33.50	V	PK
2402	72.64	-3.46	69.18	94	-24.82	V	AV
4804	42.66	0.60	43.26	74	-30.74	V	PK
4804	31.54	0.94	32.48	54	-21.52	V	AV
7206	36.58	3.72	40.30	74	-33.70	V	PK
7206	26.14	3.82	29.96	54	-24.04	V	AV

2440	86.69	-3.38	83.31	114	-30.69	H	PK
2440	72.19	-3.38	68.81	94	-25.19	H	AV
4880	44.95	0.70	45.65	74	-28.35	H	PK
4880	32.71	0.70	33.41	54	-20.59	H	AV
7320	37.34	3.79	41.13	74	-32.87	H	PK
7320	26.06	3.82	29.88	54	24.12	H	AV
2440	84.29	-3.38	80.91	114	-33.09	V	PK
2440	69.77	-3.38	66.39	94	-27.61	V	AV
4880	44.90	0.70	45.60	74	-28.40	V	PK
4880	32.65	0.70	33.35	54	-20.65	V	AV
7320	37.57	3.79	41.36	74	-32.64	V	PK
7320	26.09	3.82	29.91	54	-24.09	V	AV

2480	87.06	-3.33	83.73	114	-30.27	H	PK
2480	75.83	-3.33	72.50	94	-21.50	H	AV
4960	42.44	0.70	43.14	74	-30.86	H	PK
4960	32.15	0.77	32.92	54	-21.08	H	AV
7440	37.90	3.84	41.74	74	-32.26	H	PK
7440	26.05	3.82	29.87	54	-24.13	H	AV
2480	84.05	-3.33	80.72	114	-33.28	V	PK
2480	72.81	-3.33	69.48	94	-24.52	V	AV
4960	43.91	0.76	44.67	74	-29.37	V	PK
4960	32.27	0.77	33.04	54	-20.96	V	AV
7440	37.37	3.84	41.21	74	-32.79	V	PK
7440	26.12	3.82	29.94	54	-24.06	V	AV

5. BAND EDGE

5.1 Block Diagram of Test Setup

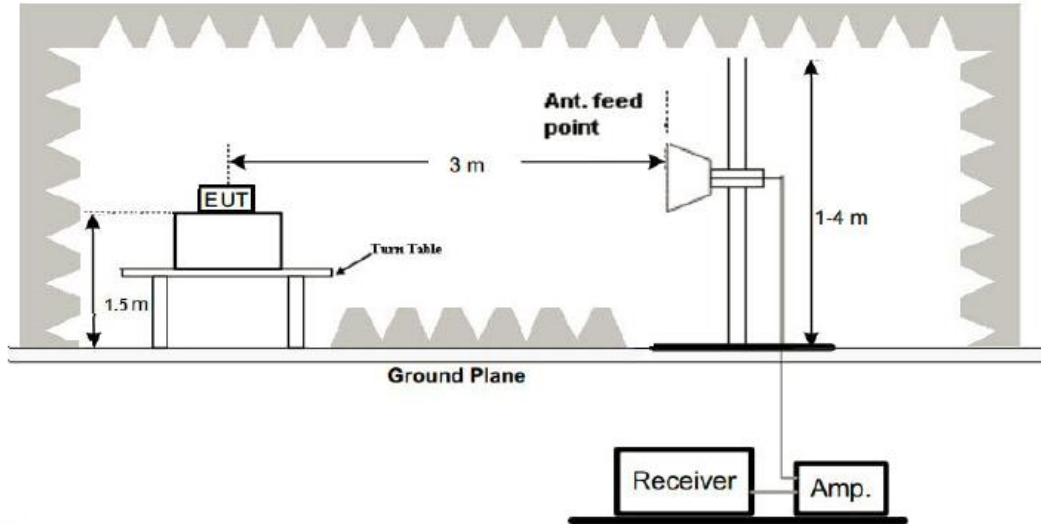

5.2 Limits

FCC PART 15.249(d) Emissions radiated outside of the specified frequency bands, except for harmonics, shall be attenuated by at least 50 dB below the level of the fundamental or to the general radiated emission limits in §15.209, whichever is the lesser attenuation.

5.3 Test Procedure

The band edge compliance of RF radiated emission should be measured by following the guidance in ANSI C63.10 with respect to maximizing the emission by rotating the EUT, measuring the emission while the EUT is situated in three orthogonal planes (if appropriate), adjusting the measurement antenna height and polarization etc. Set RBW to 1MHz and VBW to 1MHz to measure the peak field strength and set RBW to 1MHz and VBW to 1MHz to measure the average radiated field strength. The conducted RF band edge was measured by using a spectrum analyzer. Set span wide enough to capture the highest in-band emission and the emission at the band edge. Set RBW to 1MHz and VBW to 1MHz, to measure the conducted peak band edge.

5.4 Test Result

PASS

CH: Low 2402MHz
 Antenna polarization: H (Worst case)

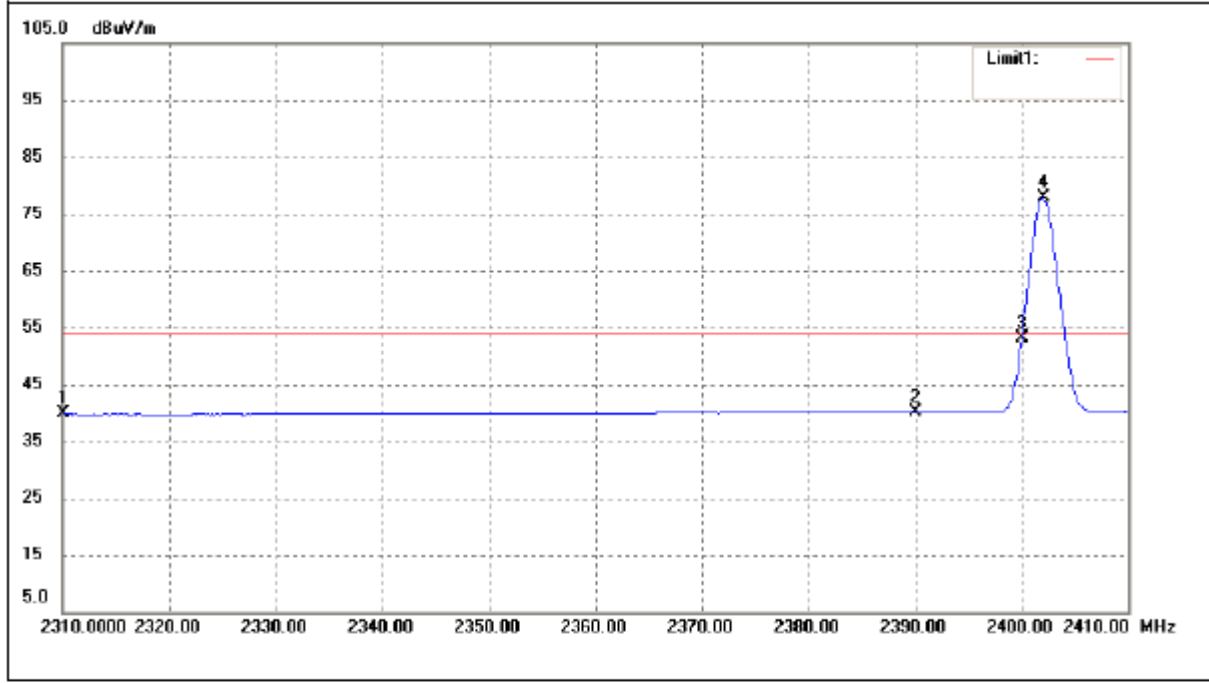

No.	Frequency (MHz)	Reading (dBuV/m)	Correct (dB/m)	Result (dBuV/m)	Limit (dBuV/m)	Margin (dB)	Remark
1	2310.000	23.47	16.34	39.81	54.00	-14.19	Ave Detector
	2310.000	35.85	16.34	52.19	74.00	-21.81	Peak Detector
2	2390.000	23.12	17.03	40.15	54.00	-13.85	Ave Detector
	2390.000	35.32	17.03	52.35	74.00	-21.65	Peak Detector
3	2400.000	36.07	17.11	53.18	54.00	-0.82	Ave Detector
	2400.000	41.43	17.11	58.54	74.00	-15.46	Peak Detector

CH: Low 2480MHz
 Antenna polarization: H(Worst case)

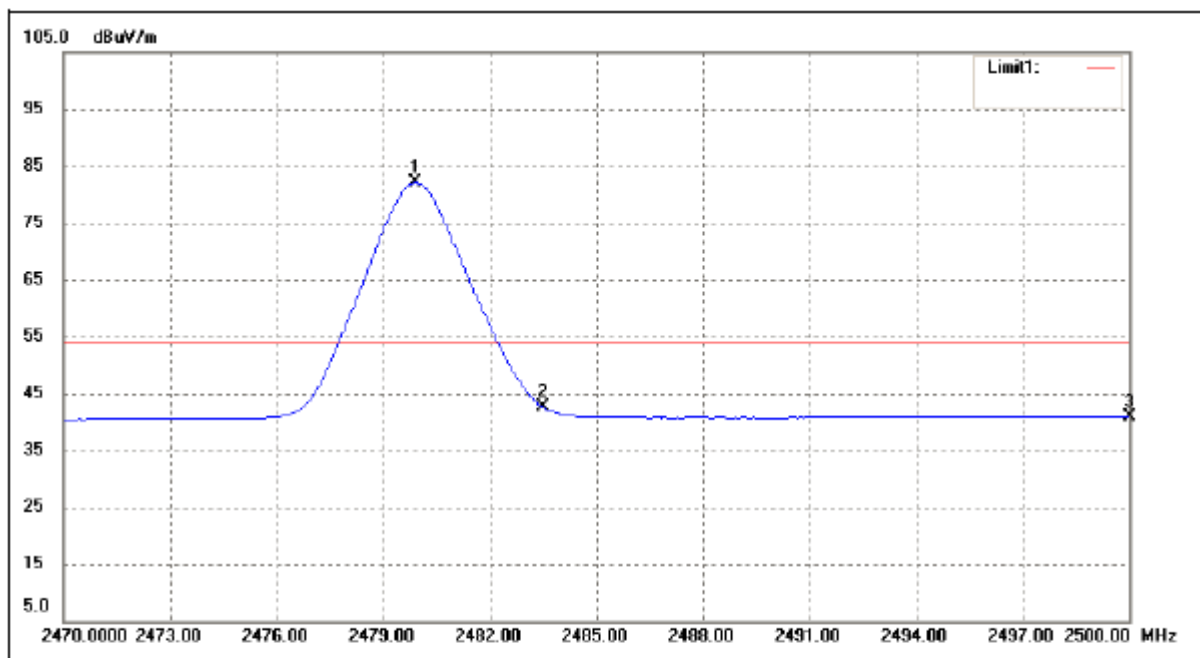

No.	Frequency (MHz)	Reading (dBuV/m)	Correct (dB/m)	Result (dBuV/m)	Limit (dBuV/m)	Margin (dB)	Remark
1	2479.900	64.38	17.71	82.09	/	/	Ave Detector
	2479.990	65.20	17.71	82.91	/	/	Peak Detector
2	2483.500	24.81	17.73	42.54	54.00	-11.46	Ave Detector
	2483.500	36.08	17.73	53.81	74.00	-20.19	Peak Detector
3	2500.000	23.03	17.86	40.89	54.00	-13.11	Ave Detector
	2500.000	35.10	17.86	52.96	74.00	-21.04	Peak Detector

6. OCCUPIED BANDWIDTH MEASUREMENT

6.1 Block Diagram of Test Setup

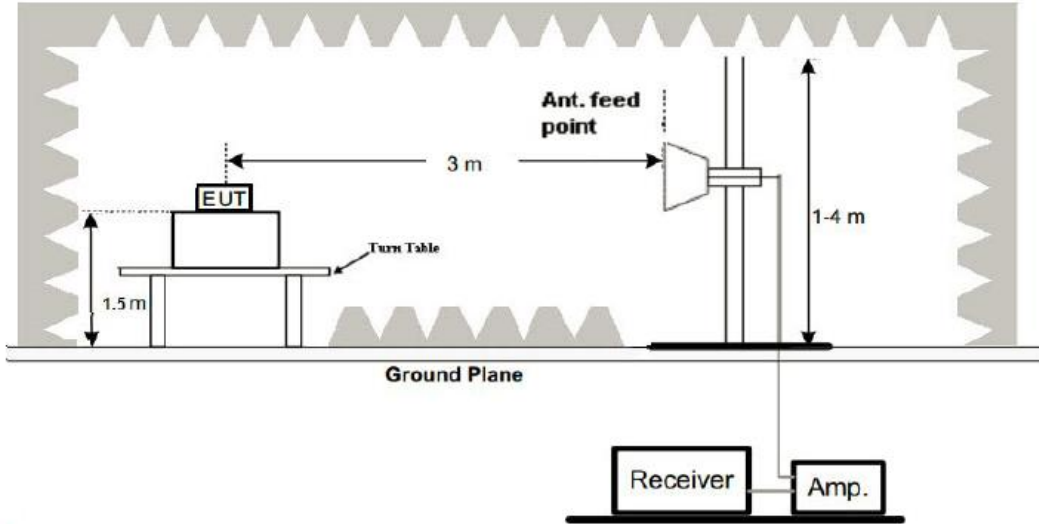

6.2 Test Procedure

1. The EUT was placed on a turn table which is 1.5m above ground plane.
2. Set EUT as operation in fixed frequency emission.
3. Based on FCC Part15 C Section 15.239(a): RBW= 30KHz. VBW= 100 KHz, Span=3MHz.
4. The useful radiated emission from the EUT was detected by the spectrum analyser with peak detector.

6.3 Test Result

PASS

Channel Frequency (MHz)	99% Bandwidth (MHz)	20dB bandwidth (MHz)	Result
2402	1.011	1.126	Pass
2440	1.013	1.128	Pass
2480	1.012	1.129	Pass

CH: 2402MHz

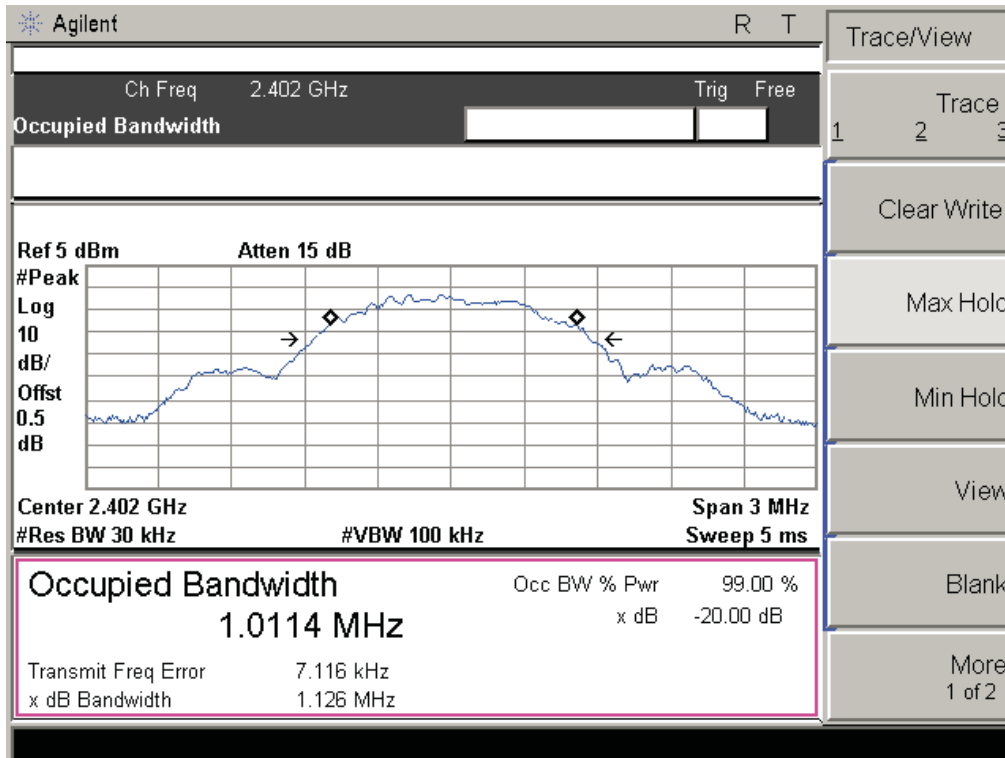

CH: 2440MHz

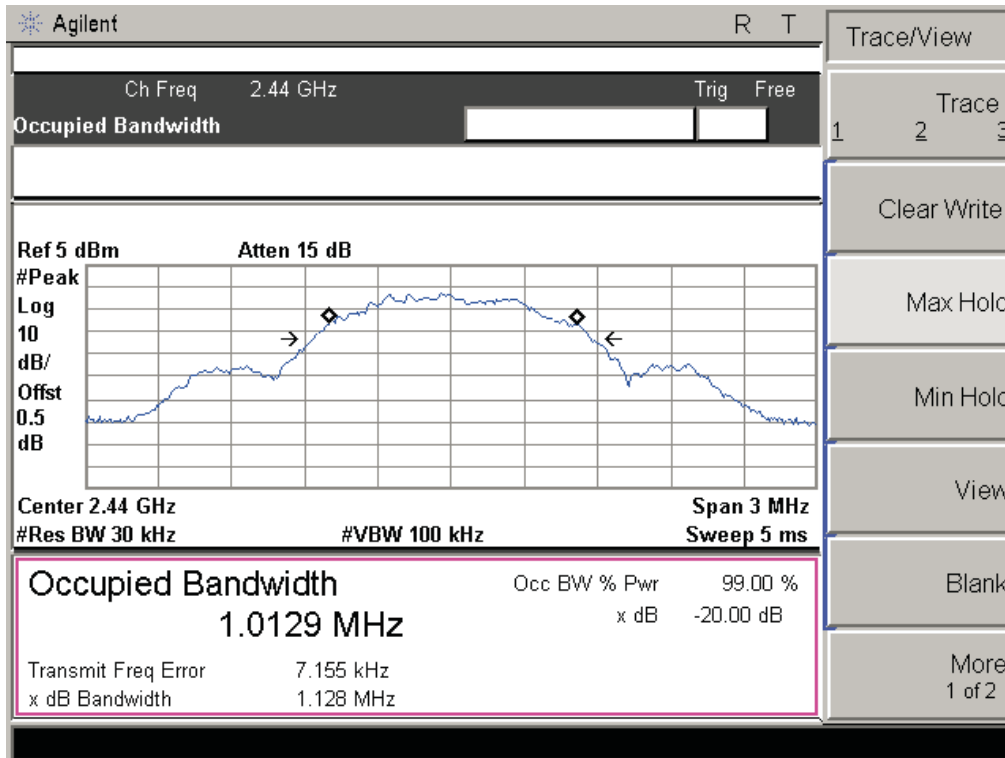

CH: 2480MHz

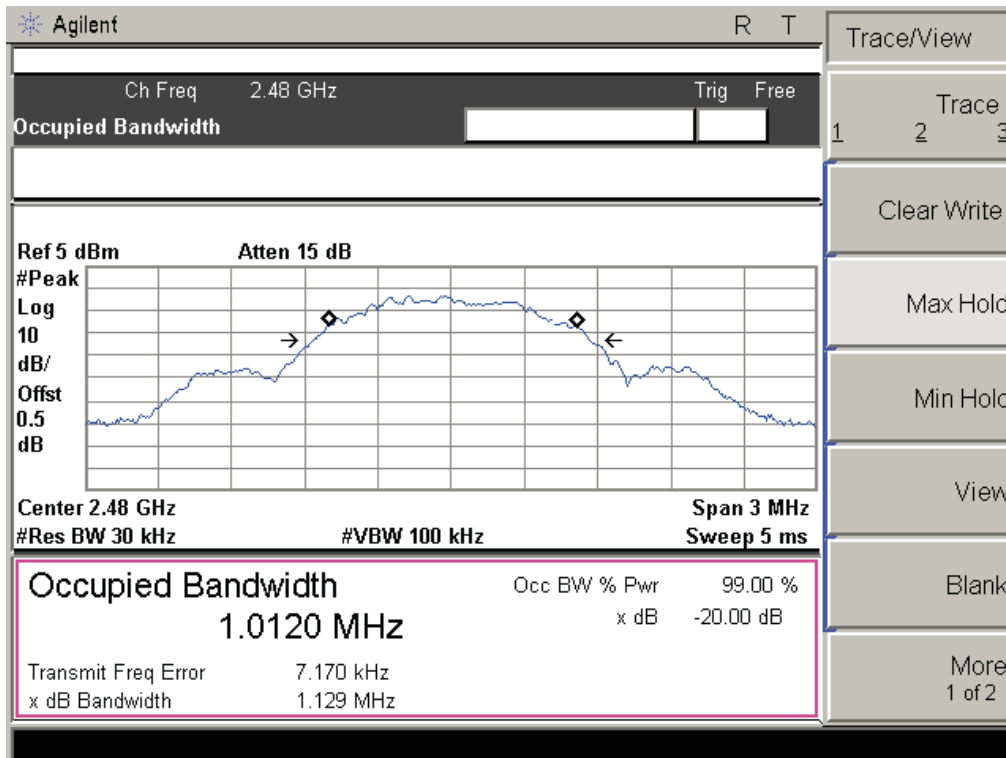

- Trace/View
- Trace 1 2 3
- Clear Write
- Max Hold
- Min Hold
- View
- Blank
- More 1 of 2

7. ANTENNA REQUIREMENT

According to Section 15.203, an intentional radiator shall be designed to ensure that no antenna other than that furnished by the responsible party shall be used with the device. Antenna is fixed by enclosure, can not be changed except take apart the product.

Antenna

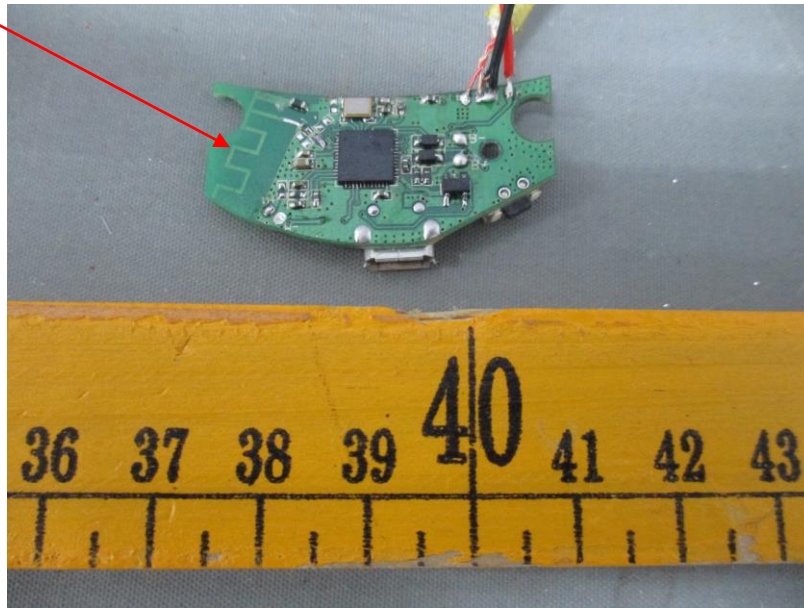

8. PHOTOGRAPH OF TEST

Radiated Emission



Power line conducted emission test

