

FCC TEST REPORT

For

WISNETWORKS Technology Co., Ltd.

Wireless Base Station

Model No.: BS5300, WLAN-LCCPE527-1, WIS-S5300

Prepared For : WISNETWORKS Technology Co., Ltd.
Address : No.77, FuTe West 3 Road, Pilot Free Trade Zone, Shanghai, China

Prepared By : Shenzhen Anbotek Compliance Laboratory Limited
Address : 1/F., Building 1, SEC Industrial Park, No.0409 Qianhai Road, Nanshan District, Shenzhen, Guangdong, China
Tel: (86) 755-26066544 Fax: (86) 755-26014772

Report Number : R0217080071W
Date of Test : Aug. 22~Sept. 12, 2017
Date of Report : Sept. 12, 2017

Contents

1. General Information	4
1.1. Client Information	4
1.2. Description of Device (EUT)	4
1.3. Auxiliary Equipment Used During Test	4
1.4. Description of Test Modes.....	5
1.5. List of channels	6
1.6. Description Of Test Setup	7
1.7. Test Equipment List.....	8
1.8. Measurement Uncertainty	9
1.9. Description of Test Facility	9
2. Summary of Test Results.....	10
3. Conducted Emission Test	11
3.1. Test Standard and Limit.....	11
3.2. Test Setup	11
3.3. Test Procedure	11
3.4. Test Data.....	11
4. Radiation Spurious Emission and Band Edge	16
4.1. Test Standard and Limit.....	16
4.2. Test Setup	17
4.3. Test Procedure	18
4.4. Test Data.....	18
5. Maximum Peak Output Power Test.....	29
5.1. Test Standard and Limit.....	29
5.2. Test Setup	29
5.3. Test Procedure	29
5.4. Test Data.....	29
6. Occupy Bandwidth Test	29
6.1. Test Standard	30
6.2. Test Setup	30
6.3. Test Procedure	30
6.4. Test Data.....	30
7. Power Spectral Density Test.....	45
7.1. Test Standard and Limit.....	45
7.2. Test Setup	45
7.3. Test Procedure	45
7.4. Test Data.....	45
8. Antenna Requirement.....	53
8.1. Test Standard and Requirement.....	53
8.2. Antenna Connected Construction.....	54
APPENDIX I -- TEST SETUP PHOTOGRAPH.....	55
APPENDIX II -- EXTERNAL PHOTOGRAPH	57
APPENDIX III -- INTERNAL PHOTOGRAPH	61

TEST REPORT

Applicant : WISNETWORKS Technology Co., Ltd.
Manufacturer : WISNETWORKS Technology Co., Ltd.
Product Name : Wireless Base Station
Model No. : BS5300, WLAN-LCCPE527-1, WIS-S5300
Trade Mark : N.A.
Rating(s) : Input DC 24V, 750mA (Adapter AC 100-240V, 50/60Hz, Output DC 24V, 750mA)

Test Standard(s) : FCC Part15 Subpart E 2016, Paragraph 15.407
Test Method(s) : ANSI C63.10: 2013,
KDB 789033 D02 General UNII Test Procedures New Rules v01r04

The device described above is tested by Shenzhen Anbotek Compliance Laboratory Limited to determine the maximum emission levels emanating from the device and the severe levels of the device can endure and its performance criterion. The measurement results are contained in this test report and Shenzhen Anbotek Compliance Laboratory Limited is assumed full of responsibility for the accuracy and completeness of these measurements. Also, this report shows that the EUT (Equipment Under Test) is technically compliant with the FCC Part 15 Subpart E requirements.

This report applies to above tested sample only and shall not be reproduced in part without written approval of Shenzhen Anbotek Compliance Laboratory Limited.

Date of Test : Aug. 22~Sept. 12, 2017

Prepared by :



Winkey Wang

(Tested Engineer / Winkey Wang)

Reviewer :

Tangcy. T.

(Project Manager / Tangcy. T)

Approved & Authorized Signer :

Tom Chen

(Manager / Tom Chen)

1. General Information

1.1. Client Information

Applicant	:	WISNETWORKS Technology Co., Ltd.
Address	:	No.77, FuTe West 3 Road, Pilot Free Trade Zone, Shanghai, China
Manufacturer	:	WISNETWORKS Technology Co., Ltd.
Address	:	No.77, FuTe West 3 Road, Pilot Free Trade Zone, Shanghai, China

1.2. Description of Device (EUT)

Product Name	:	Wireless Base Station	
Model No.	:	BS5300, WLAN-LCCPE527-1, WIS-S5300 (Note: All samples are the same except the model number and colour, so we prepare "BS5300" for test only.)	
Trade Mark	:	N.A	
Test Power Supply	:	AC 120V, 60Hz for adapter/AC 240V, 60Hz for adapter Input DC 24V, 750mA (Adapter AC 100-240V, 50/60Hz, Output DC 24V, 750mA)	
Product Description	:	Operation Frequency:	5745MHz~5825MHz
		Number of Channel:	5 Channels for 802.11n(HT20) 2 Channels for 802.11n(HT40)
		Modulation Type:	OFDM with BPSK/QPSK/16QAM/64QAM for 802.11n
		Antenna Type:	Rod Antenna 2X2 MIMO
		Antenna Gain(Peak):	5G WIFI ANT 1: 7dBi 5G WIFI ANT 2: 7dBi
<p>Remark: 1) For a more detailed features description, please refer to the manufacturer's specifications or the User's Manual. 2) For 802.11n mode, directional gain=GANT +10log(N)dBi =10.1dBi</p>			

1.3. Auxiliary Equipment Used During Test

Adapter	:	M/N: POE 2.4G (Gigabit) Input: 100-240V~50/60Hz Output: DC 24V, 750mA Remark: The adapter was provided by customer.
---------	---	--

1.4. Description of Test Modes

To investigate the maximum EMI emission characteristics generates from EUT, the test system was pre-scanning tested base on the consideration of following EUT operation mode or test configuration mode which possible have effect on EMI emission level. Each of these EUT operation mode(s) or test configuration mode(s) mentioned above was evaluated respectively.

Mode	Test channel	Frequency (MHz)
OFDM(802.11n20)	CH 149	5745MHz
	CH 157	5785MHz
	CH 165	5825MHz
OFDM(802.11n40)	CH 151	5755MHz
	CH159	5795MHz

Note:

1. The measurements are performed at the highest, middle, lowest available channels.
2. The EUT has been tested as an independent unit. And Continual Transmitting in maximum power.
3. For the relevant Conducted Measurement, the temporary antenna connector is used during the measurement. Antenna Connector Impedance: 50 Ω , Cable Loss: 1.0 dB
4. The EUT was programmed to be in continuously transmitting mode and the transmit duty cycle is more than 98%

1.5. List of channels

802.11n20

Channel	Freq. (MHz)	Channel	Freq. (MHz)
149	5745	153	5765
157	5785	161	5805
165	5825		

802.11n40

Channel	Freq. (MHz)	Channel	Freq. (MHz)
151	5755	159	5795

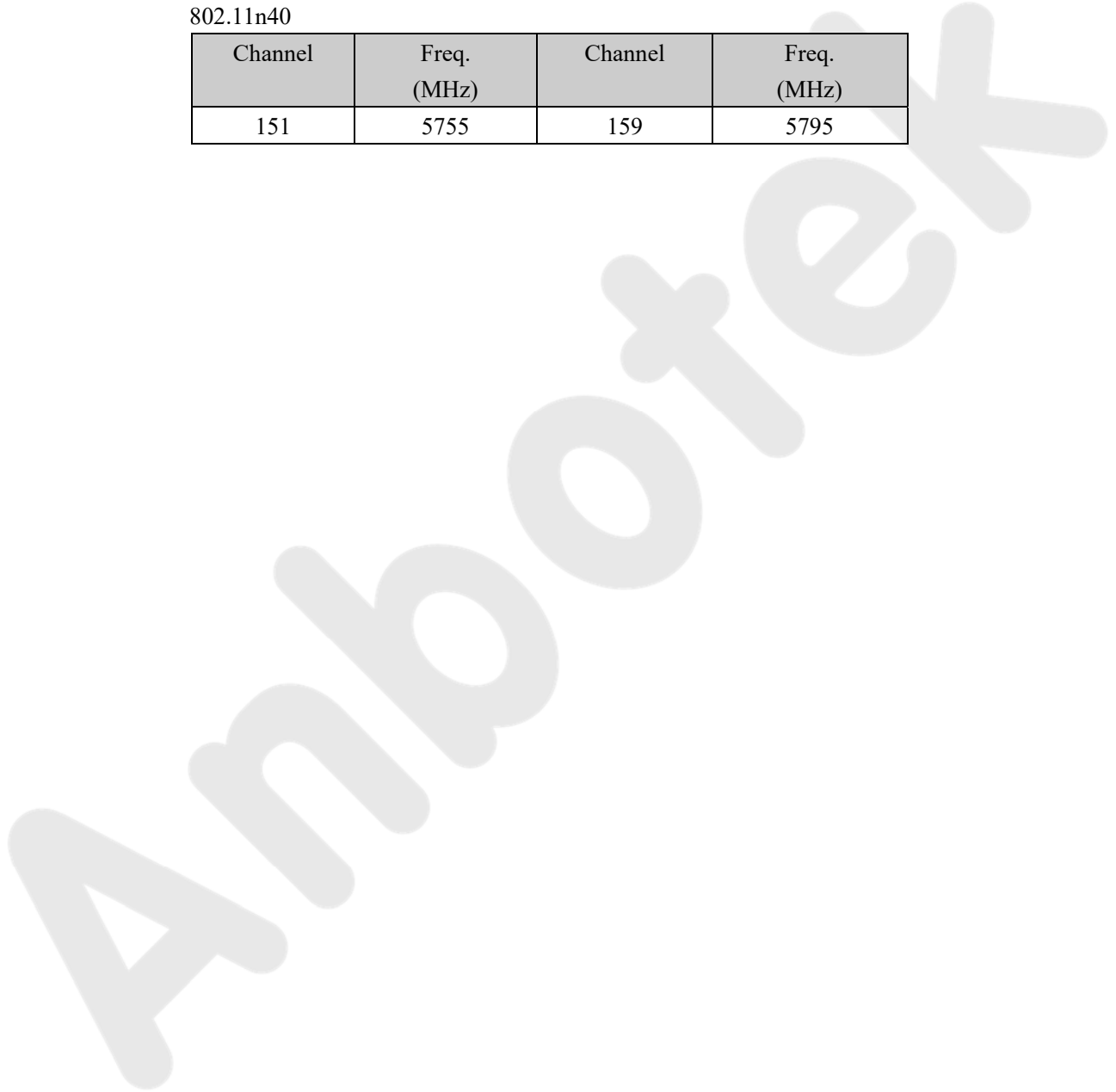

1.6. Description Of Test Setup

CE

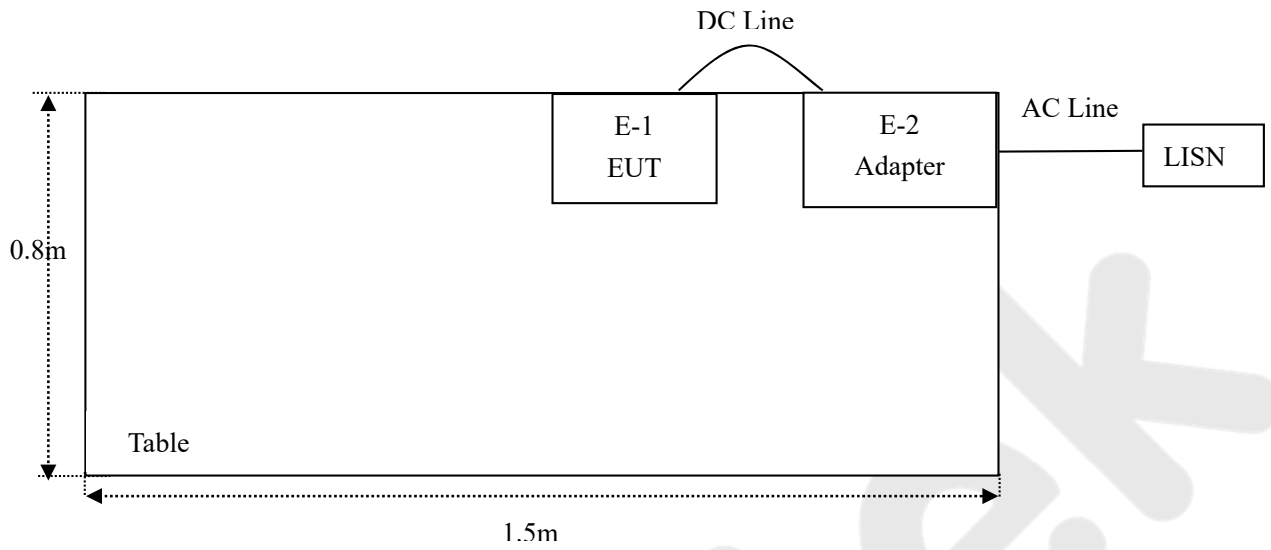

RE

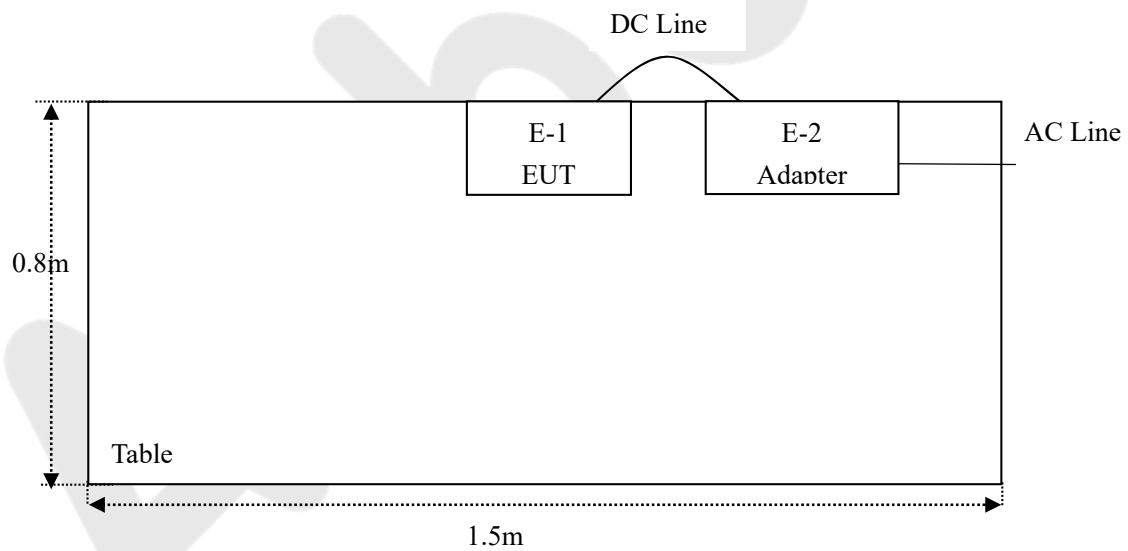

1.7. Test Equipment List

Item	Equipment	Manufacturer	Model No.	Serial No.	Last Cal.	Cal. Interval
1.	L.I.S.N. Artificial Mains Network	Rohde & Schwarz	ENV216	100055	May 27, 2017	1 Year
2.	EMI Test Receiver	Rohde & Schwarz	ESCI	100627	May 27, 2017	1 Year
3.	RF Switching Unit	Compliance Direction	RSU-M2	38303	May 27, 2017	1 Year
4.	Spectrum Analysis	Agilent	E4407B	US39390582	May 27, 2017	1 Year
5.	Preamplifier	SKET Electronic	BK1G18G30 D	KD17503	May 27, 2017	1 Year
6.	EMI Test Receiver	Rohde & Schwarz	ESPI	101604	May 27, 2017	1 Year
7.	Double Ridged Horn Antenna	Instruments corporation	GTH-0118	351600	May 31, 2017	1 Year
8.	Bilog Broadband Antenna	Schwarzbeck	VULB9163	VULB 9163-289	May 31, 2017	1 Year
9.	Loop Antenna	Schwarzbeck	HFH2-Z2	100047	Apr. 03, 2017	1 Year
10.	Pre-amplifier	SONOMA	310N	186860	May 27, 2017	1 Year
11.	EMI Test Software EZ-EMC	SHURPLE	N/A	N/A	N/A	N/A
12.	Power Sensor	DAER	RPR3006W	15I00041SN045	May 27, 2017	1 Year
13.	Power Sensor	DAER	RPR3006W	15I00041SN046	May 27, 2017	1 Year
14.	Power Meter	Agilent	N1914A	MY50001102	May 27, 2017	1 Year
15.	Power Sensor	Agilent	N8481H	MY51240001	May 27, 2017	1 Year
16.	MXA Spectrum Analysis	Agilent	N9020A	MY51170037	May 27, 2017	1 Year
17.	MXG RF Vector Signal Generator	Agilent	N5182A	MY48180656	May 27, 2017	1 Year
18.	Signal Generator	Agilent	E4421B	MY41000743	May 27, 2017	1 Year
19.	DC Power supply	IVYTECH	IV6003	1601D6030007	May 26, 2017	1 Year
20.	TEMP&HUMI PROGRAMMABLE CHAMBER	Sertep	ZJ- HWHS80B	ZJ-17042804	Mar. 03, 2017	1 Year

1.8. Measurement Uncertainty

Radiation Uncertainty	:	Ur = 4.1 dB (Horizontal)
		Ur = 4.3 dB (Vertical)
Conduction Uncertainty	:	Uc = 3.4dB

1.9. Description of Test Facility

The test facility is recognized, certified, or accredited by the following organizations:

FCC-Designation No.: CN5023

Shenzhen Anbotek Compliance Laboratory Limited, EMC Laboratory has been registered and fully described in a report filed with the (FCC) Federal Communications Commission. The acceptance letter from the FCC is maintained in our files. Designation CN5023, July 31, 2017.

ISED-Registration No.: 8058A-1

Shenzhen Anbotek Compliance Laboratory Limited, EMC Laboratory has been registered and fully described in a report filed with the (ISED) Innovation, Science and Economic Development Canada. The acceptance letter from the ISED is maintained in our files. Registration 8058A-1, June 13, 2016.

Test Location

All Emissions tests were performed at
Shenzhen Anbotek Compliance Laboratory Limited. at 1/F., Building 1, SEC Industrial Park, No.0409 Qianhai Road, Nanshan District, Shenzhen, Guangdong, China

2. Summary of Test Results

Standard	Test Type	Result
15.207 & 15.407	Conducted Emission	PASS
15.205/15.209	Spurious Emission	PASS
15.407(b)	Band Edge	PASS
15.407(a)(5)	Occupy Bandwidth	PASS
15.407(a)(1)(3)	Maximum Conducted Output Power	PASS
15.407(a)(1)(3)	Peak Power Spectral Density	PASS
15.203/15.407g	Antenna Requirement	PASS

3. Conducted Emission Test

3.1. Test Standard and Limit

Test Standard	FCC Part15 Section 15.207&15.407		
Test Limit	Frequency	Maximum RF Line Voltage (dBuV)	
		Quasi-peak Level	Average Level
	150kHz~500kHz	66 ~ 56 *	56 ~ 46 *
	500kHz~5MHz	56	46
5MHz~30MHz	60	50	

Remark: (1) *Decreasing linearly with logarithm of the frequency.
(2) The lower limit shall apply at the transition frequency.

3.2. Test Setup

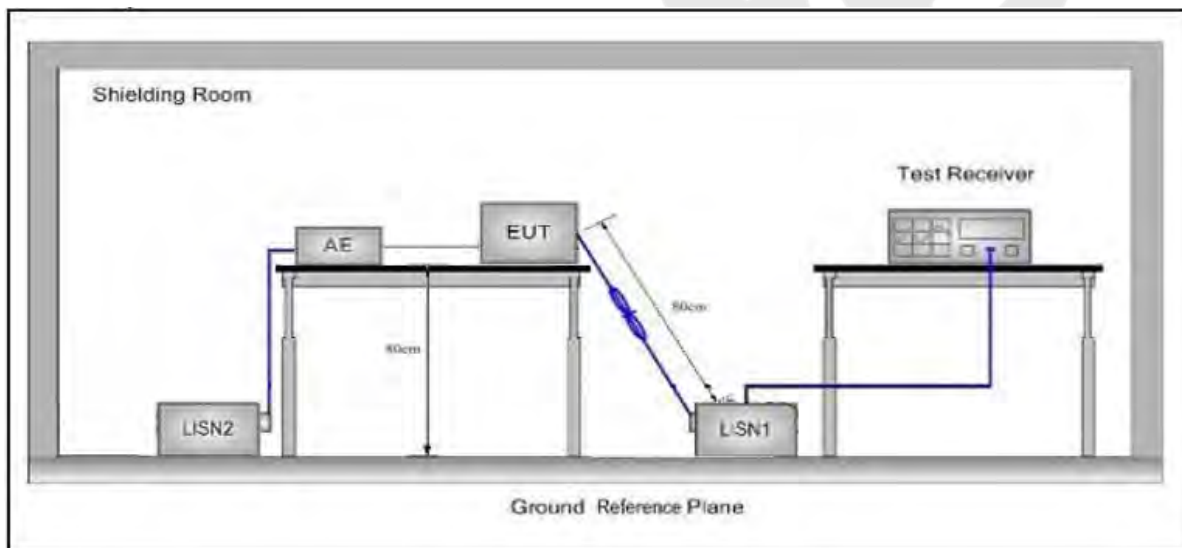

3.3. Test Procedure

The EUT system is connected to the power mains through a line impedance stabilization network (L.I.S.N.). This provides a 50ohm coupling impedance for the EUT system. Please refer the block diagram of the test setup and photographs. Both sides of AC line are checked to find out the maximum conducted emission. In order to find the maximum emission levels, the relative positions of equipment and all of the interface cables shall be changed according to FCC ANSI C63.10-2013 on Conducted Emission Measurement.

The bandwidth of test receiver (ESCI) set at 9kHz.

The frequency range from 150kHz to 30MHz is checked.

3.4. Test Data

Please to see the following pages

Conducted Emission Test Data

Test Site: 1# Shielded Room
 Operating Condition: Keeping TX mode
 Test Specification: AC 120V, 60Hz for adapter
 Comment: Live Line
 Tem.:25°C Hum.:50%

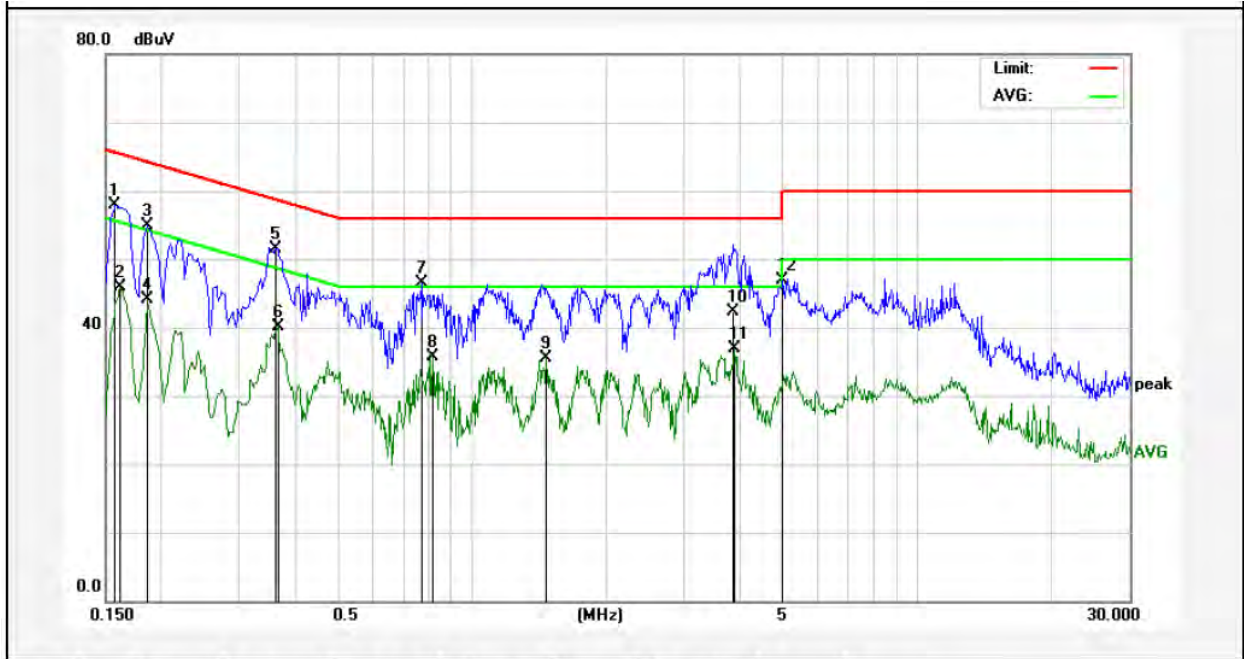

No.	Freq. (MHz)	Reading (dBuV)	Factor (dB)	Result (dBuV)	Limit dBuV	Over Limit (dB)	Detector	Remark
1	0.1580	38.05	19.90	57.95	65.56	-7.61	QP	
2	0.1620	25.99	19.90	45.89	55.36	-9.47	AVG	
3	0.1860	35.05	19.90	54.95	64.21	-9.26	QP	
4	0.1860	24.29	19.90	44.19	54.21	-10.02	AVG	
5	0.3620	31.59	19.92	51.51	58.68	-7.17	QP	
6	0.3660	20.28	19.92	40.20	48.59	-8.39	AVG	
7	0.7700	26.47	20.06	46.53	56.00	-9.47	QP	
8	0.8139	15.59	20.07	35.66	46.00	-10.34	AVG	
9	1.4700	15.34	20.13	35.47	46.00	-10.53	AVG	
10	3.8700	22.14	20.18	42.32	56.00	-13.68	QP	
11	3.8940	16.74	20.18	36.92	46.00	-9.08	AVG	
12	4.9899	26.60	20.21	46.81	56.00	-9.19	QP	

Conducted Emission Test Data

Test Site: 1# Shielded Room
 Operating Condition: Keeping TX mode
 Test Specification: AC 120V, 60Hz for adapter
 Comment: Neutral Line
 Tem.:25°C Hum.:50%

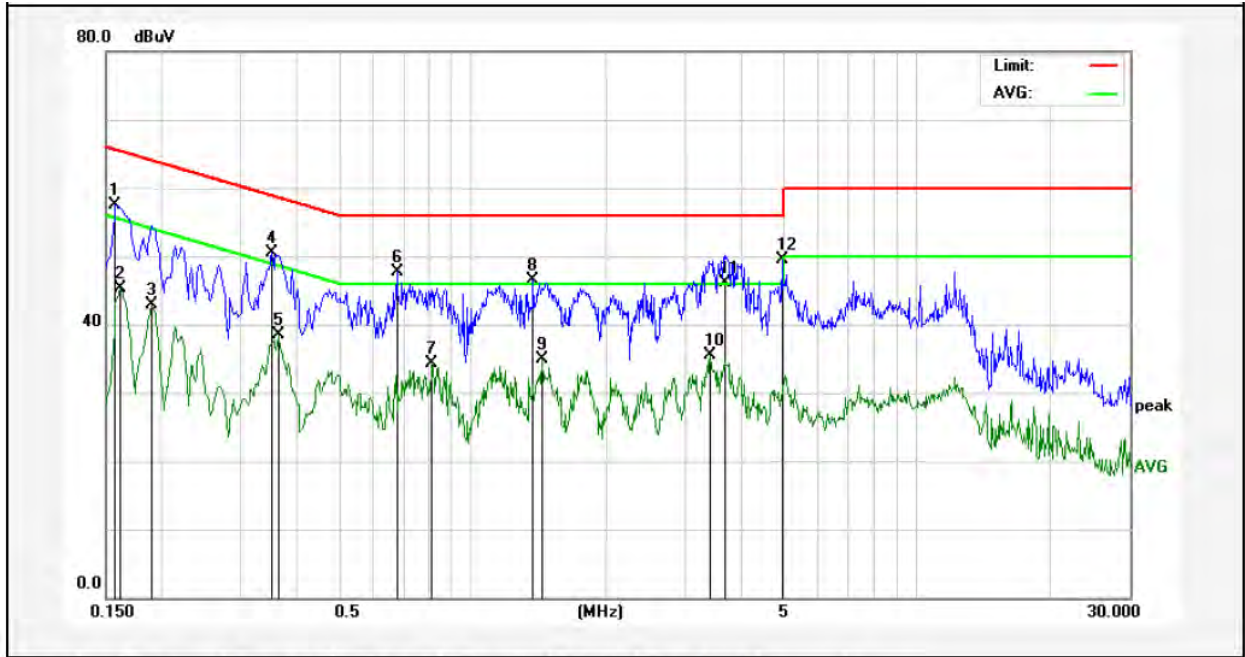

No.	Freq. (MHz)	Reading (dBuV)	Factor (dB)	Result (dBuV)	Limit dBuV	Over Limit (dB)	Detector	Remark
1	0.1580	37.66	19.90	57.56	65.56	-8.00	QP	
2	0.1620	25.43	19.90	45.33	55.36	-10.03	AVG	
3	0.1900	23.02	19.90	42.92	54.03	-11.11	AVG	
4	0.3540	30.51	19.91	50.42	58.87	-8.45	QP	
5	0.3660	18.67	19.92	38.59	48.59	-10.00	AVG	
6	0.6780	27.66	20.03	47.69	56.00	-8.31	QP	
7	0.8139	14.23	20.07	34.30	46.00	-11.70	AVG	
8	1.3700	26.30	20.13	46.43	56.00	-9.57	QP	
9	1.4380	14.80	20.13	34.93	46.00	-11.07	AVG	
10	3.4260	15.28	20.17	35.45	46.00	-10.55	AVG	
11	3.6900	25.87	20.17	46.04	56.00	-9.96	QP	
12	4.9660	29.27	20.21	49.48	56.00	-6.52	QP	

Conducted Emission Test Data

Test Site: 1# Shielded Room
 Operating Condition: Keeping TX mode
 Test Specification: AC 240V, 60Hz for adapter
 Comment: Live Line
 Tem.:25°C Hum.:50%

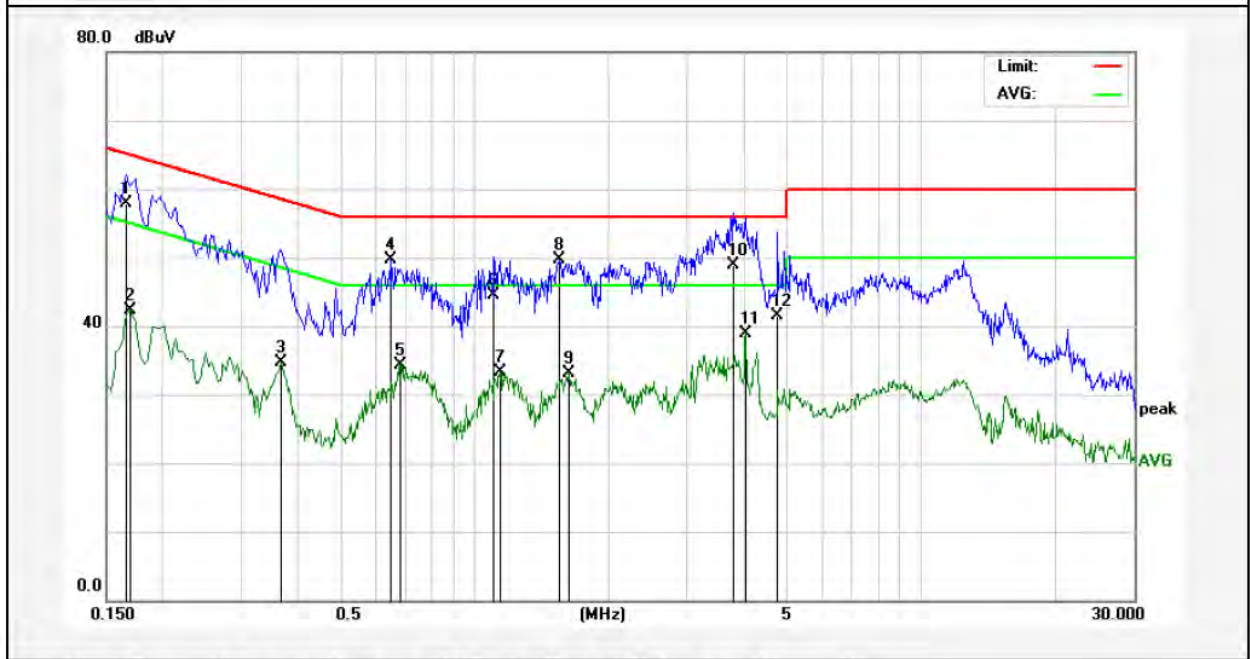

No.	Freq. (MHz)	Reading (dBuV)	Factor (dB)	Result (dBuV)	Limit dBuV	Over Limit (dB)	Detector	Remark
1	0.1660	37.95	19.90	57.85	65.15	-7.30	QP	
2	0.1700	22.45	19.90	42.35	54.96	-12.61	AVG	
3	0.3700	14.71	19.92	34.63	48.50	-13.87	AVG	
4	0.6540	29.64	20.03	49.67	56.00	-6.33	QP	
5	0.6860	14.21	20.04	34.25	46.00	-11.75	AVG	
6	1.1060	24.32	20.12	44.44	56.00	-11.56	QP	
7	1.1460	13.20	20.12	33.32	46.00	-12.68	AVG	
8	1.5500	29.61	20.13	49.74	56.00	-6.26	QP	
9	1.6340	12.90	20.13	33.03	46.00	-12.97	AVG	
10	3.8100	28.72	20.18	48.90	56.00	-7.10	QP	
11	4.0620	18.74	20.18	38.92	46.00	-7.08	AVG	
12	4.7940	21.38	20.20	41.58	56.00	-14.42	QP	

Conducted Emission Test Data

Test Site: 1# Shielded Room
 Operating Condition: Keeping TX mode
 Test Specification: AC 240V, 60Hz for adapter
 Comment: Neutral Line
 Tem.:25°C Hum.:50%

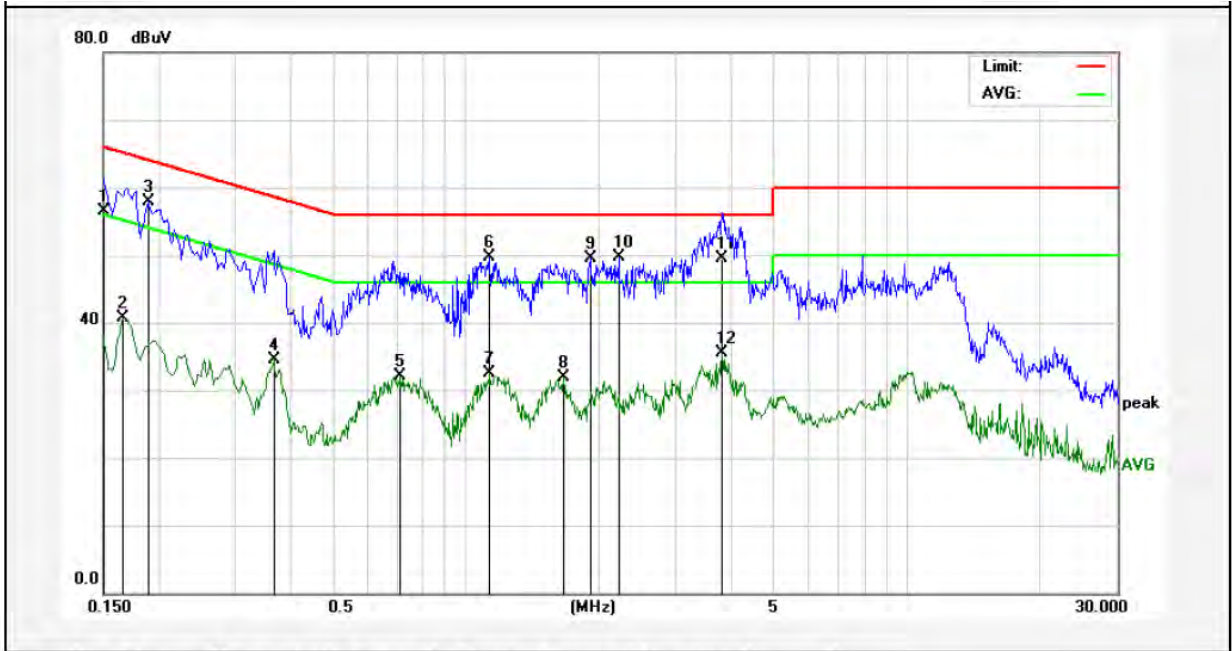

No.	Freq. (MHz)	Reading (dBuV)	Factor (dB)	Result (dBuV)	Limit dBuV	Over Limit (dB)	Detector	Remark
1	0.1500	36.59	19.90	56.49	65.99	-9.50	QP	
2	0.1660	20.89	19.90	40.79	55.15	-14.36	AVG	
3	0.1900	38.02	19.90	57.92	64.03	-6.11	QP	
4	0.3660	14.54	19.92	34.46	48.59	-14.13	AVG	
5	0.7100	12.01	20.04	32.05	46.00	-13.95	AVG	
6	1.1260	29.50	20.12	49.62	56.00	-6.38	QP	
7	1.1300	12.36	20.12	32.48	46.00	-13.52	AVG	
8	1.6660	11.86	20.13	31.99	46.00	-14.01	AVG	
9	1.9180	29.42	20.14	49.56	56.00	-6.44	QP	
10	2.2180	29.51	20.14	49.65	56.00	-6.35	QP	
11	3.8180	29.32	20.18	49.50	56.00	-6.50	QP	
12	3.8180	15.38	20.18	35.56	46.00	-10.44	AVG	

4. Radiation Spurious Emission and Band Edge

4.1. Test Standard and Limit

Test Standard	FCC Part15 C Section 15.209, 15.205 and 15.407, KDB 789033 D02 General UNII Test Procedures New Rules v01r04
---------------	---

Unwanted spurious emissions fallen in restricted bands per FCC Part15.205 shall comply with the general field strength limits set forth in § 15.209 as below table,

	Frequency (MHz)	Field strength (microvolt/meter)	Limit (dBuV/m)	Remark	Measurement distance (m)
Test Limit	0.009MHz~0.490MHz	2400/F(kHz)	-	-	300
	0.490MHz-1.705MHz	24000/F(kHz)	-	-	30
	1.705MHz-30MHz	30	-	-	30
	30MHz~88MHz	100	40.0	Quasi-peak	3
	88MHz~216MHz	150	43.5	Quasi-peak	3
	216MHz~960MHz	200	46.0	Quasi-peak	3
	960MHz~1000MHz	500	54.0	Quasi-peak	3
	Above 1000MHz	500	54.0	Average	3

Remark:

(1)The lower limit shall apply at the transition frequency.

(2) 15.35(b), Unless otherwise specified, the limit on peak radio frequency emissions is 20dB above the maximum permitted average emission limit applicable to the equipment under test. This peak limit applies to the total peak emission level radiated by the device.

(3) Above 1GHz limit: $E[\text{dB}\mu\text{V/m}] = \text{EIRP}[\text{dBm}] + 95.2 = 68.2 \text{ dB}\mu\text{V/m}$, for $\text{EIRP}[\text{dBm}] = -27\text{dBm}$.

For transmitters operating in the 5.725-5.85GHz band:

15.407(b)(4)(i) All emissions shall be limited to a level of -27dBm/MHz at 75MHz or more above or below the band edge increasing linearly to 10dBm/MHz at 25MHz above or below the band edge, and from 25MHz above or below the band edge increasing linearly to a level of 15.6dBm/MHz at 5MHz above or below the band edge, and from 5MHz above or below the band edge increasing linearly to a level of 27dBm/MHz at the band edge.

KDB789033 D02 v01r04 (G)(2)(c)

(i) Sections 15.407(b)(1) to (b)(3) specify the unwanted emission limits for the U-NII-1 and U-NII-2 bands. As specified, emissions above 1000 MHz that are outside of the restricted bands are subject to a peak emission limit of -27dBm/MHz.³

(ii) Section 15.407(b)(4) specifies the unwanted emission limit for the U-NII-3 band. A band emissions mask is specified in Section 15.407(b)(4)(i). The emission limits are in terms of a Peak detector. An alternative to the band emissions mask is specified in Section 15.407(b)(4)(ii). The alternative limits are based on the highest antenna gain specified in the filing. There are also marketing and importation restrictions for the devices using the alternative limit.⁴

Note 3: An out-of-band emission that complies with both the average and peak limits of Section 15.209 is not

required to satisfy the -27 dBm/MHz peak emission limit.

Note 4: Only devices with antenna gains of 10 dBi or less may be approved using the emission limits specified in Section 15.247(d) till March 2, 2018; all other devices operating in this band must use the mask specified in Section 15.407(b)(4)(i).

4.2. Test Setup

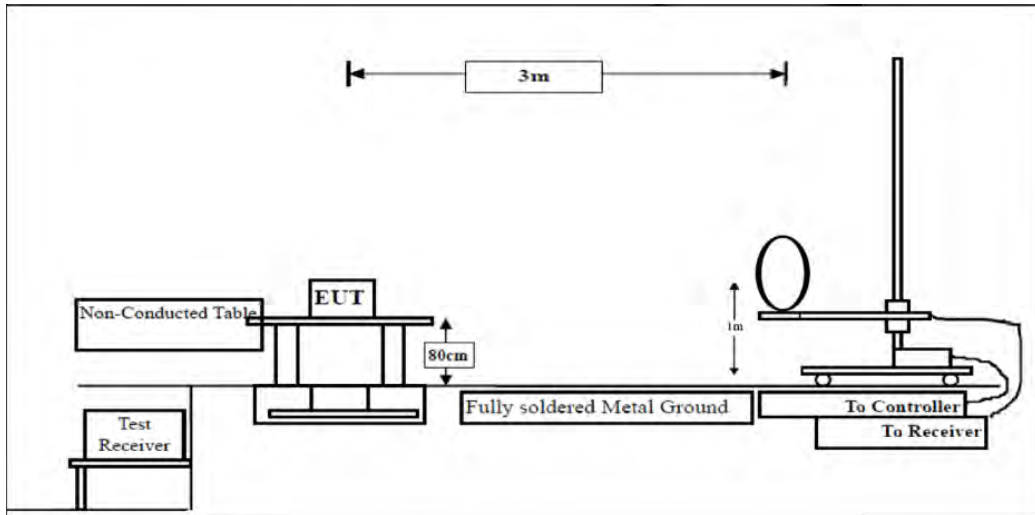

Figure 1. Below 30MHz

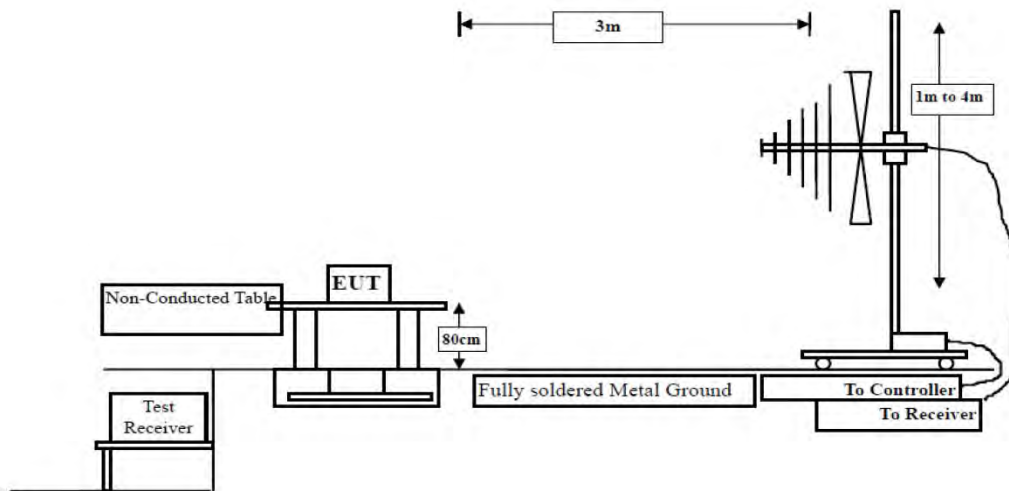

Figure 2. 30MHz to 1GHz

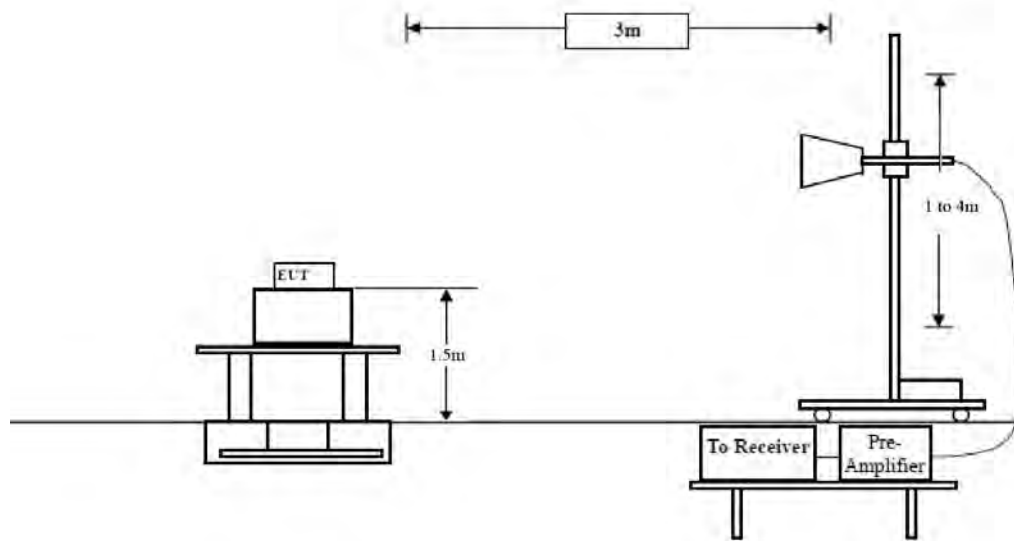

Figure 3. Above 1 GHz

4.3. Test Procedure

For below 1GHz: The EUT is placed on a turntable, which is 0.8m above the ground plane.

For above 1GHz: The EUT is placed on a turntable, which is 1.5m above the ground plane.

The turn table can rotate 360 degrees to determine the position of the maximum emission level. The EUT is set 3 meters away from the receiving antenna which is mounted on a antenna tower. The antenna can be moved up and down from 1 to 4 meters to find out the maximum emission level. Rotated the EUT through three orthogonal axes to determine the maximum emissions, both horizontal and vertical polarization of the antenna are set on test. The EUT is tested in 9*6*6 Chamber. The device is evaluated in xyz orientation.

For 9kHz to 150kHz, Set the spectrum analyzer as:

RBW = 200Hz, VBW =1kHz, Detector= Quasi-Peak, Trace mode= Max hold, Sweep- auto couple.

For 150kHz to 30MHz, Set the spectrum analyzer as:

RBW = 9KHz, VBW =30kHz, Detector= Quasi-Peak, Trace mode= Max hold, Sweep- auto couple.

For 30MHz to 1000MHz, Set the spectrum analyzer as:

RBW = 100kHz, VBW =300kHz, Detector= Quasi-Peak, Trace mode= Max hold, Sweep- auto couple.

.

For above 1GHz, Set the spectrum analyzer as:

RBW =1MHz, VBW =1MHz, Detector= Peak, Trace mode= Max hold, Sweep- auto couple.

RBW =1MHz, VBW =10Hz, Detector= Average, Trace mode= Max hold, Sweep- auto couple.

4.4. Test Data

PASS

The test results of 9kHz-30MHz and above 18000MHz are attenuated more than 20dB below the permissible limits, so the results don't record in the report.

Test Results (30~1000MHz)

Job No.: 0217080071W Temp.(°C)/Hum.(%RH): 24.3°C/55%RH
 Standard: FCC PART 15C Power Source: AC 120V/60Hz
 Test Mode: TX Mode Polarization: Horizontal

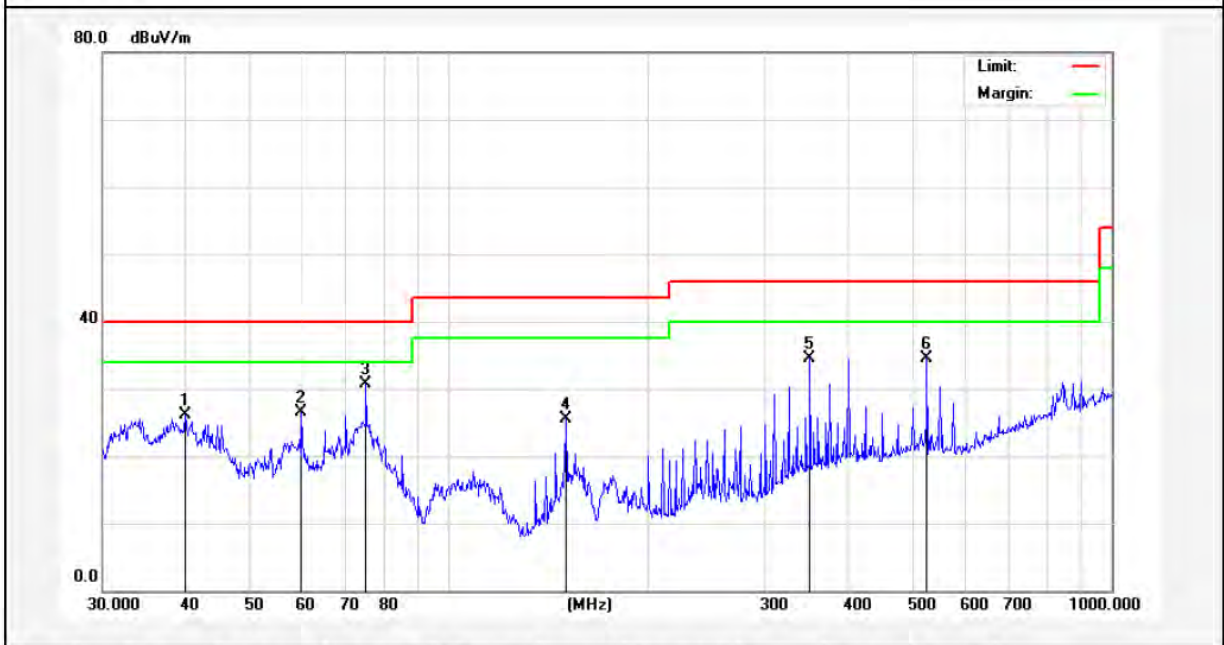

No.	Freq. (MHz)	Reading (dBuV/m)	Factor (dB/m)	Result (dBuV/m)	Limit (dBuV/)	Over Limit (dB)	Detector	Height (cm)	degree (deg)	Remark
1	39.9942	36.89	-10.87	26.02	40.00	-13.98	QP	300	13	
2	59.8588	41.93	-15.38	26.55	40.00	-13.45	QP	300	46	
3	74.9191	51.23	-20.59	30.64	40.00	-9.36	QP	300	79	
4	150.0108	48.80	-23.34	25.46	43.50	-18.04	QP	300	104	
5	350.4768	48.42	-13.97	34.45	46.00	-11.55	QP	300	201	
6	526.3967	45.54	-11.03	34.51	46.00	-11.49	QP	300	314	



Test Results (30~1000MHz)

Job No.: 0217080071W Temp.(°C)/Hum.(%RH): 24.3°C/55%RH
 Standard: FCC PART 15C Power Source: AC 120V/60Hz
 Test Mode: TX Mode Polarization: Vertical

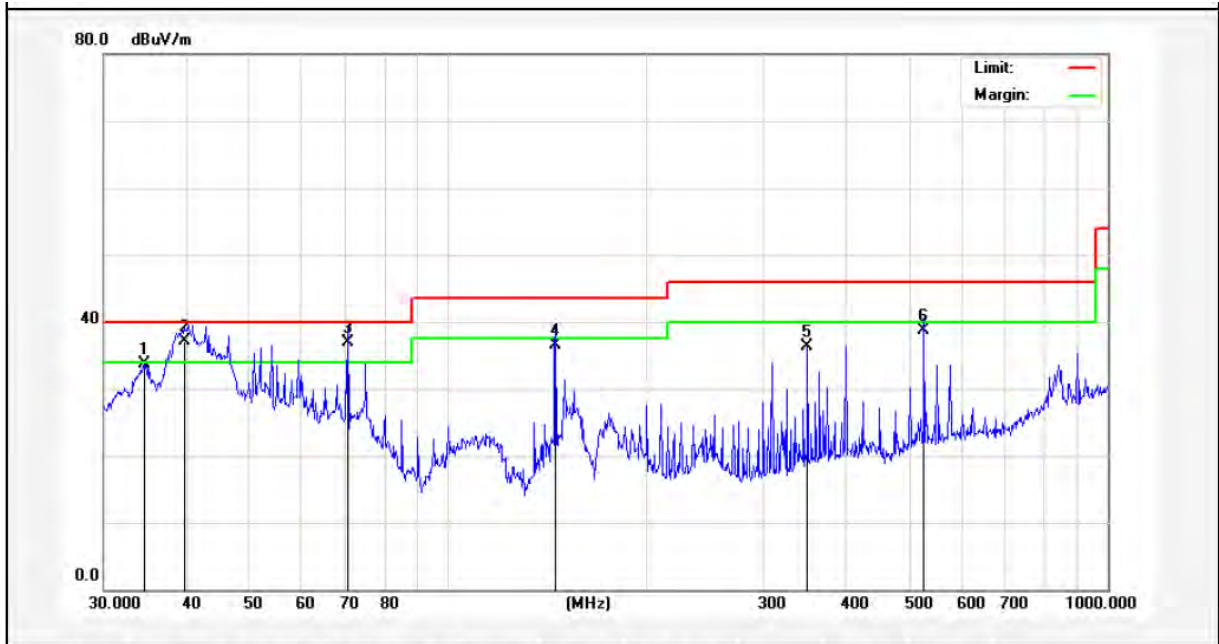

No.	Freq. (MHz)	Reading (dBuV/m)	Factor (dB/m)	Result (dBuV/m)	Limit (dBuV/)	Over Limit (dB)	Detector	Height (cm)	degree (deg)	Remark
1	34.5173	48.45	-14.78	33.67	40.00	-6.33	QP	300	13	
2	39.9781	47.95	-10.89	37.06	40.00	-2.94	QP	300	46	
3	70.3365	56.65	-19.69	36.96	40.00	-3.04	QP	300	79	
4	145.3506	54.82	-18.41	36.41	43.50	-7.09	QP	300	101	
5	350.4768	49.20	-12.97	36.23	46.00	-9.77	QP	300	134	
6	526.3967	49.12	-10.51	38.61	46.00	-7.39	QP	300	204	



Test Results (Above 1000MHz)

Test mode:	IEEE 802.11n(HT20)	Test channel:	Low CH
------------	--------------------	---------------	--------

Peak value:

Frequency (MHz)	Read Level (dBuV)	Antenna Factor (dB/m)	Cable Loss (dB)	Preamp Factor (dB)	Level (dBuV/m)	Limit Line (dBuV/m)	Over Limit (dB)	Pol.
11490.00	39.81	32.21	17.15	33.90	55.27	74.00	-18.73	V
17235.00	36.21	32.74	20.08	34.86	54.17	68.20	-14.03	V
11490.00	37.15	32.21	17.15	33.90	52.61	74.00	-21.39	H
17235.00	36.25	32.74	20.08	34.86	54.21	68.20	-13.99	H

Average value:

Frequency (MHz)	Read Level (dBuV)	Antenna Factor (dB/m)	Cable Loss (dB)	Preamp Factor (dB)	Level (dBuV/m)	Limit Line (dBuV/m)	Over Limit (dB)	Pol.
11490.00	31.12	32.21	17.15	33.90	46.58	54.00	-7.42	V
17235.00	28.32	32.74	20.08	34.86	46.28	54.00	-7.72	V
11490.00	30.57	32.21	17.15	33.90	46.03	54.00	-7.97	H
17235.00	28.35	32.74	20.08	34.86	46.31	54.00	-7.69	H

Test mode:	IEEE 802.11n(HT20)	Test channel:	Mid CH
------------	--------------------	---------------	--------

Peak value:

Frequency (MHz)	Read Level (dBuV)	Antenna Factor (dB/m)	Cable Loss (dB)	Preamp Factor (dB)	Level (dBuV/m)	Limit Line (dBuV/m)	Over Limit (dB)	Pol.
11570.00	40.35	32.44	17.18	33.91	56.06	68.20	-12.14	V
17355.00	39.12	32.78	20.12	34.86	57.16	68.20	-11.04	V
11570.00	38.35	32.44	17.18	33.91	54.06	68.20	-14.14	H
17355.00	36.12	32.78	20.12	34.86	54.16	68.20	-14.04	H

Average value:

Frequency (MHz)	Read Level (dBuV)	Antenna Factor (dB/m)	Cable Loss (dB)	Preamp Factor (dB)	Level (dBuV/m)	Limit Line (dBuV/m)	Over Limit (dB)	Pol.
11570.00	29.13	32.44	17.18	33.91	44.84	54.00	-9.16	V
17355.00	27.32	32.78	20.12	34.86	45.36	54.00	-8.64	V
11570.00	29.03	32.44	17.18	33.91	44.74	54.00	-9.26	H
17355.00	28.36	32.78	20.12	34.86	46.40	54.00	-7.60	H

Test mode:	IEEE 802.11n(HT20)	Test channel:	High CH
------------	--------------------	---------------	---------

Peak value:

Frequency (MHz)	Read Level (dBuV)	Antenna Factor (dB/m)	Cable Loss (dB)	Preamp Factor (dB)	Level (dBuV/m)	Limit Line (dBuV/m)	Over Limit (dB)	Pol.
11650.00	41.21	32.59	18.02	33.92	57.90	68.20	-10.30	V
17475.00	38.35	32.87	20.15	34.88	56.49	68.20	-11.71	V
11650.00	36.23	32.59	18.02	33.92	52.92	68.20	-15.28	H
17475.00	38.13	32.87	20.15	34.88	56.27	68.20	-11.93	H

Average value:

Frequency (MHz)	Read Level (dBuV)	Antenna Factor (dB/m)	Cable Loss (dB)	Preamp Factor (dB)	Level (dBuV/m)	Limit Line (dBuV/m)	Over Limit (dB)	Pol.
11650.00	31.25	32.59	18.02	33.92	47.94	54.00	-6.06	V
17475.00	32.41	32.87	20.15	34.88	50.55	54.00	-3.45	V
11650.00	29.32	32.59	18.02	33.92	46.01	54.00	-7.99	H
17475.00	28.74	32.87	20.15	34.88	46.88	54.00	-7.12	H

Test mode:	IEEE 802.11n(HT40)	Test channel:	Low CH
------------	--------------------	---------------	--------

Peak value:

Frequency (MHz)	Read Level (dBuV)	Antenna Factor (dB/m)	Cable Loss (dB)	Preamp Factor (dB)	Level (dBuV/m)	Limit Line (dBuV/m)	Over Limit (dB)	Pol.
11510.00	37.76	31.98	17.08	33.91	52.91	68.20	-15.29	V
17265.00	35.87	32.65	20.03	34.85	53.70	68.20	-14.50	V
11510.00	37.63	31.98	17.08	33.91	52.78	68.20	-15.42	H
17265.00	35.74	32.65	20.03	34.85	53.57	68.20	-14.63	H

Average value:

Frequency (MHz)	Read Level (dBuV)	Antenna Factor (dB/m)	Cable Loss (dB)	Preamp Factor (dB)	Level (dBuV/m)	Limit Line (dBuV/m)	Over Limit (dB)	Pol.
11510.00	30.11	31.98	17.08	33.91	45.26	54.00	-8.74	V
17265.00	28.83	32.65	20.03	34.85	46.66	54.00	-7.34	V
11510.00	30.11	31.98	17.08	33.91	45.26	54.00	-8.74	H
17265.00	27.34	32.65	20.03	34.85	45.17	54.00	-8.83	H

Test mode:	IEEE 802.11n(HT40)	Test channel:	High CH
------------	--------------------	---------------	---------

Peak value:

Frequency (MHz)	Read Level (dBuV)	Antenna Factor (dB/m)	Cable Loss (dB)	Preamp Factor (dB)	Level (dBuV/m)	Limit Line (dBuV/m)	Over Limit (dB)	Pol.
11590.00	42.25	32.59	18.02	33.92	58.94	68.20	-9.26	V
17385.00	39.12	32.87	20.15	34.88	57.26	68.20	-10.94	V
11590.00	37.41	32.59	18.02	33.92	54.10	68.20	-14.10	H
17385.00	38.53	32.87	20.15	34.88	56.67	68.20	-11.53	H

Average value:

Frequency (MHz)	Read Level (dBuV)	Antenna Factor (dB/m)	Cable Loss (dB)	Preamp Factor (dB)	Level (dBuV/m)	Limit Line (dBuV/m)	Over Limit (dB)	Pol.
11590.00	32.13	32.59	18.02	33.92	48.82	54.00	-5.18	V
17385.00	29.49	32.87	20.15	34.88	47.63	54.00	-6.37	V
11590.00	31.47	32.59	18.02	33.92	48.16	54.00	-5.84	H
17385.00	28.41	32.78	20.12	34.86	46.45	54.00	-7.55	H

Note:

1. Final Level = Receiver Read level + Antenna Factor + Cable Loss - Preamplifier Factor

Radiated Band Edge:

Test Mode: 802.11n20								
Peak Value								
Frequency (MHz)	Read Level (dBuV)	Antenna Factor (dB/m)	Cable Loss (dB)	Preamp Factor (dB)	Level (dBuV/m)	Limit (dBuV/m)	Over Limit (dB)	Pol.
5725.00	41.95	28.65	14.89	31.04	54.45	68.20	-13.75	H
5850.00	42.79	29.16	15.68	31.96	55.67	68.20	-12.53	H
5725.00	42.60	28.65	14.89	31.04	55.10	68.20	-13.10	V
5850.00	44.20	29.16	15.68	31.96	57.08	68.20	-11.12	V
Average Value								
Frequency (MHz)	Read Level (dBuV)	Antenna Factor (dB/m)	Cable Loss (dB)	Preamp Factor (dB)	Level (dBuV/m)	Limit (dBuV/m)	Over Limit (dB)	Pol.
5725.00	35.44	28.65	14.89	31.04	47.94	54.00	-6.06	H
5850.00	33.97	29.16	15.68	31.96	46.85	54.00	-7.15	H
5725.00	34.99	28.65	14.89	31.04	47.49	54.00	-6.51	V
5850.00	34.70	29.16	15.68	31.96	47.58	54.00	-6.42	V

Test Mode: 802.11n40								
Peak Value								
Frequency (MHz)	Read Level (dBuV)	Antenna Factor (dB/m)	Cable Loss (dB)	Preamp Factor (dB)	Level (dBuV/m)	Limit (dBuV/m)	Over Limit (dB)	Pol.
5725.00	40.77	28.65	14.89	31.04	53.27	68.20	-14.93	H
5850.00	41.98	29.16	15.68	31.96	54.86	68.20	-13.34	H
5725.00	41.01	28.65	14.89	31.04	53.51	68.20	-14.69	V
5850.00	41.77	29.16	15.68	31.96	54.65	68.20	-13.55	V
Average Value								
Frequency (MHz)	Read Level (dBuV)	Antenna Factor (dB/m)	Cable Loss (dB)	Preamp Factor (dB)	Level (dBuV/m)	Limit (dBuV/m)	Over Limit (dB)	Pol.
5725.00	33.89	28.65	14.89	31.04	46.39	54.00	-7.61	H
5850.00	33.79	29.16	15.68	31.96	46.67	54.00	-7.33	H
5725.00	32.78	28.65	14.89	31.04	45.28	54.00	-8.72	V
5850.00	34.77	29.16	15.68	31.96	47.65	54.00	-6.35	V

For conducted test:

ANT 1

802.11n(20): Band Edge, Left Side

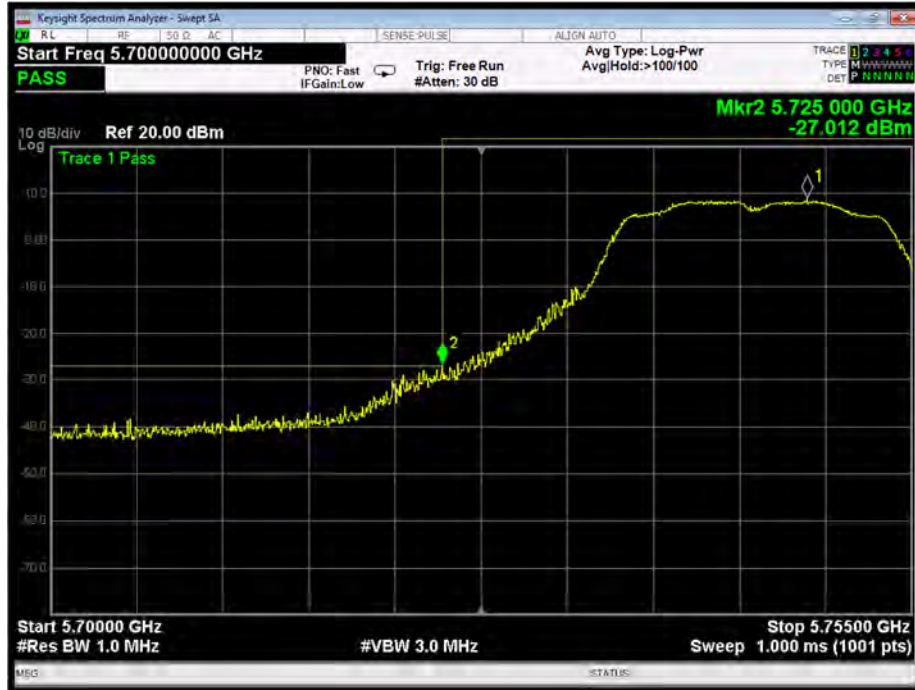

802.11n(20): Band Edge, Right Side



802.11n(40): Band Edge, Left Side



802.11n(40): Band Edge, Right Side



ANT 2

802.11n(20): Band Edge, Left Side



802.11n(20): Band Edge, Right Side

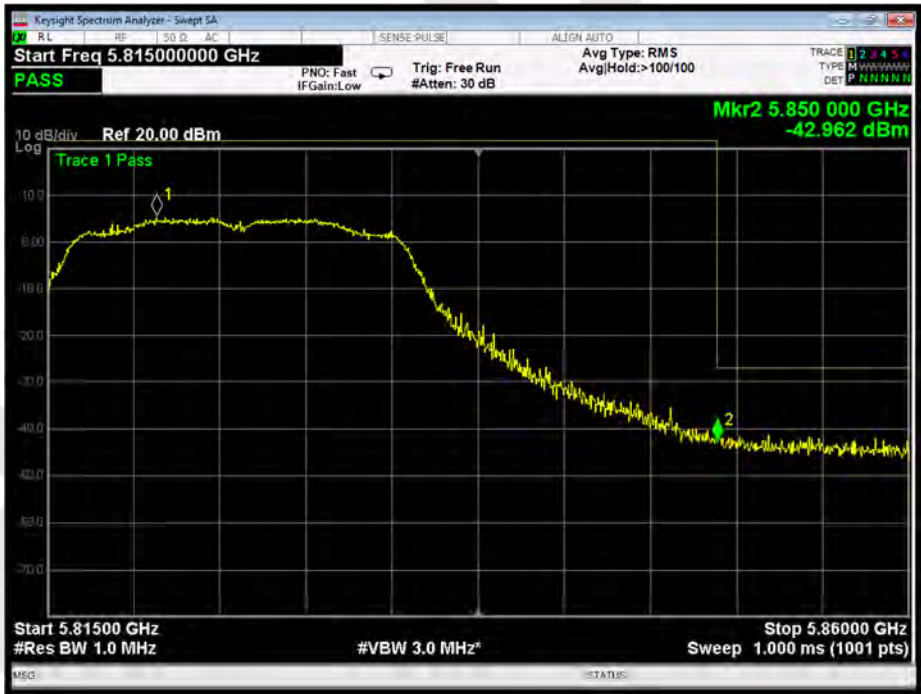

802.11n(40): Band Edge, Left Side



802.11n(40): Band Edge, Right Side



5. Maximum Peak Output Power Test

5.1. Test Standard and Limit

Test Standard	FCC Part15 C Section 15.407 (a)(1) (3)
Test Limit	30dBm (1W)

5.2. Test Setup

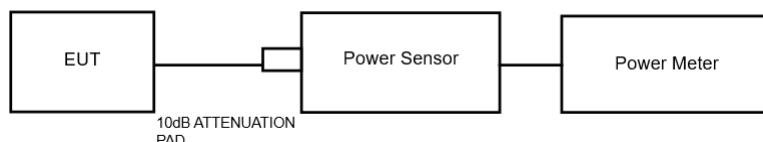

5.3. Test Procedure

1. The Transmitter output (antenna port) was connected to the power meter.
2. Turn on the EUT and power meter and then record the power value.
3. Repeat above procedures on all channels needed to be tested.

Note: The cable loss and attenuator loss were offset into measure device as an amplitude offset.

5.4. Test Data

Test Item	: Max. peak output power	Test Mode	: CH Low ~ CH High
Test Voltage	: AC 120V/60Hz	Temperature	: 24°C
Test Result	: PASS	Humidity	: 55%RH

Mode	Channel Frequency (MHz)	Peak Power output (dBm)			Correctional Limit (dBm)	Results
		ANT1	ANT2	SUM		
802.11n20	5745	18.40	18.55	21.49	25.90	PASS
	5785	18.00	17.89	20.96	25.90	PASS
	5825	17.46	17.61	20.55	25.90	PASS
802.11n40	5755	18.41	18.51	21.47	25.90	PASS
	5795	18.03	18.49	21.28	25.90	PASS

Note:

- 1) For power test the duty cycle is 100% in continuous transmitting mode. Please see the plot of next page.
- 2) Directional gain=GANT +10log(N)dBi =7+10log2=10.1dBi
 Power limit Reduction=10.1-6=4.1dBi
 Correctional limit=30-4.1=25.9dBi

6. Occupy Bandwidth Test

6.1. Test Standard

Test Standard	FCC Part15 C Section 15.403(i), 15.407 (e)
---------------	--

6.2. Test Setup

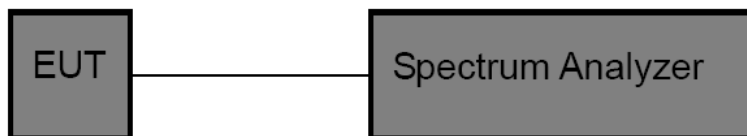

6.3. Test Procedure

1. Place the EUT on the table and set it in the transmitting mode.
2. Remove the antenna from the EUT and then connect a low loss RF cable from the antenna port to the spectrum analyzer.

3. Set the spectrum analyzer as:

26 dB & 99% bandwidth

- RBW = approximately 1% of the emission bandwidth;
- Set the VBW > RBW;
- Detector = Peak
- Trace mode = Max hold.
- Sweep - auto couple.

6 dB bandwidth

- RBW = 100kHz;
- Set the video bandwidth (VBW) ≥ 3 RBW;
- Detector = Peak
- Trace mode = Max hold.
- Sweep - auto couple.

4. Measure the maximum width of the emission that is 26dB /6dB down from the maximum of the emission. Compare this with the RBW setting of the analyzer.
5. Repeat until all the rest channels are investigated.

6.4. Test Data

ANT 1

Test Item : 6dB & 26dB BW
 Test Voltage : AC 120V/60Hz
 Test Result : PASS

Test Mode : CH Low ~ CH High
 Temperature : 24°C
 Humidity : 55%RH

Mode	Channel Frequency (MHz)	6dB BW(MHz)	Limit	Results
802.11n20	5745	15.46	>0.5MHz	PASS
	5785	15.13		PASS
	5825	15.12		PASS
802.11n40	5755	35.20		PASS
	5795	35.21		PASS

Mode	Channel Frequency (MHz)	26dB BW(MHz)	99% Bandwidth (MHz)
802.11n20	5745	24.97	17.825
	5785	23.31	17.735
	5825	24.01	17.790
802.11n40	5755	44.42	36.180
	5795	44.11	36.194

ANT 2

Test Item	: 6dB & 26dB BW	Test Mode	: CH Low ~ CH High
Test Voltage	: AC 120V/60Hz	Temperature	: 24°C
Test Result	: PASS	Humidity	: 55%RH

Mode	Channel Frequency (MHz)	6dB BW(MHz)	Limit	Results
802.11n20	5745	15.15	>0.5MHz	PASS
	5785	15.14		PASS
	5825	15.08		PASS
802.11n40	5755	33.94		PASS
	5795	35.21		PASS

Mode	Channel Frequency (MHz)	26dB BW(MHz)	99% Bandwidth (MHz)
802.11n20	5745	24.00	17.748
	5785	23.57	17.730
	5825	24.65	17.786
802.11n40	5755	44.12	36.162
	5795	44.29	36.193

6dB Bandwidth

ANT 1

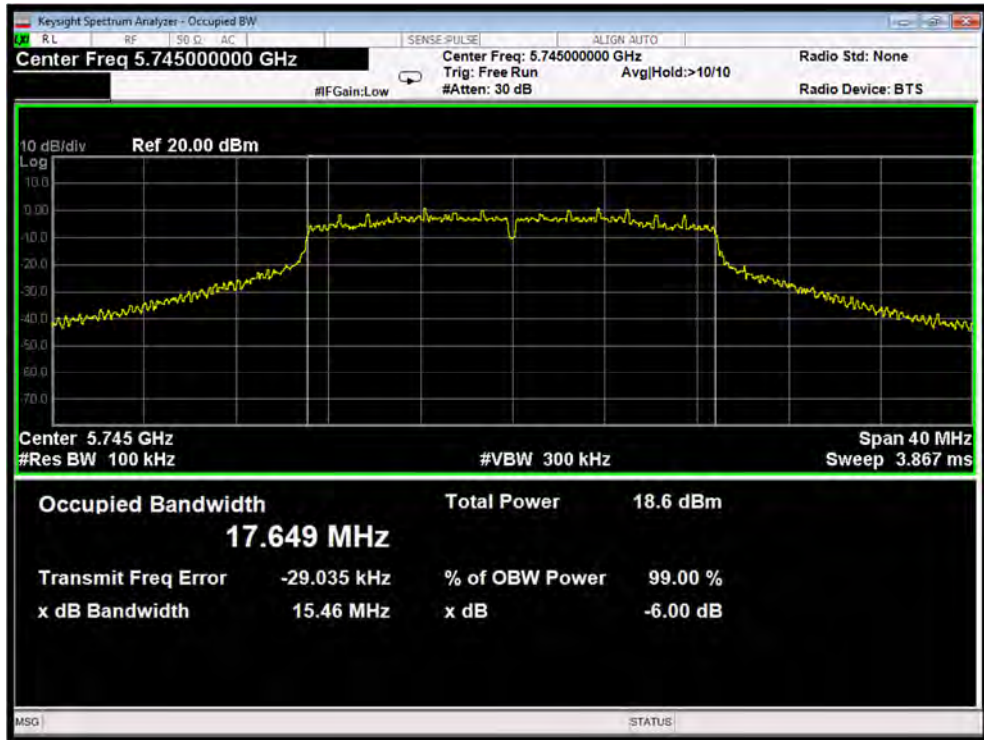

Test Mode: 802.11n20---Low

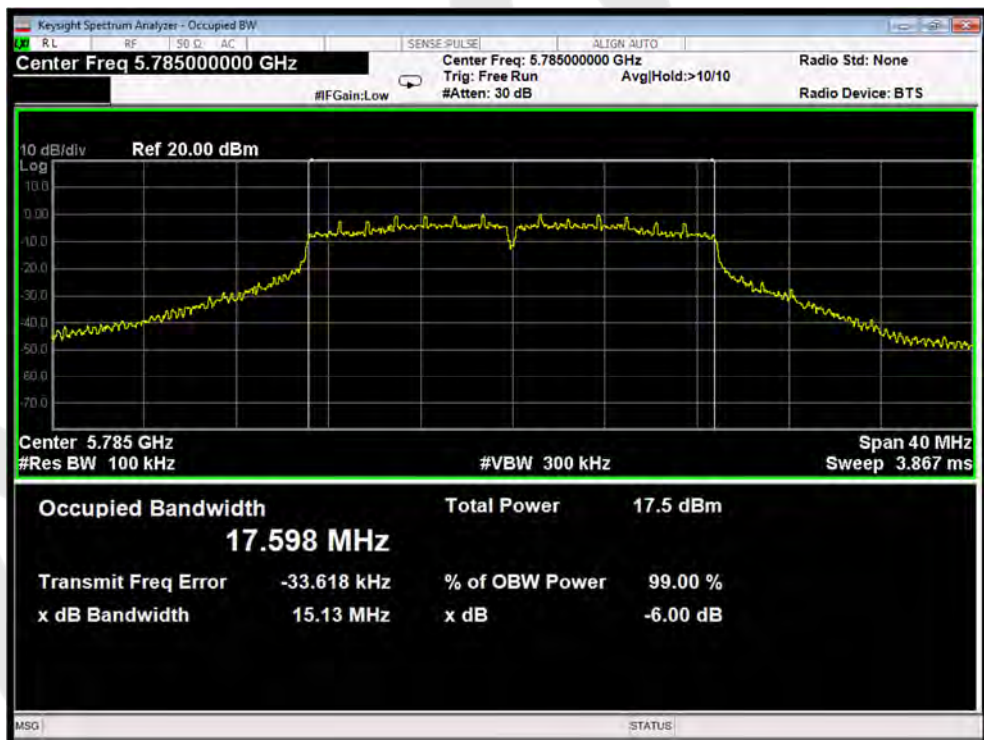

Test Mode: 802.11n20---Middle

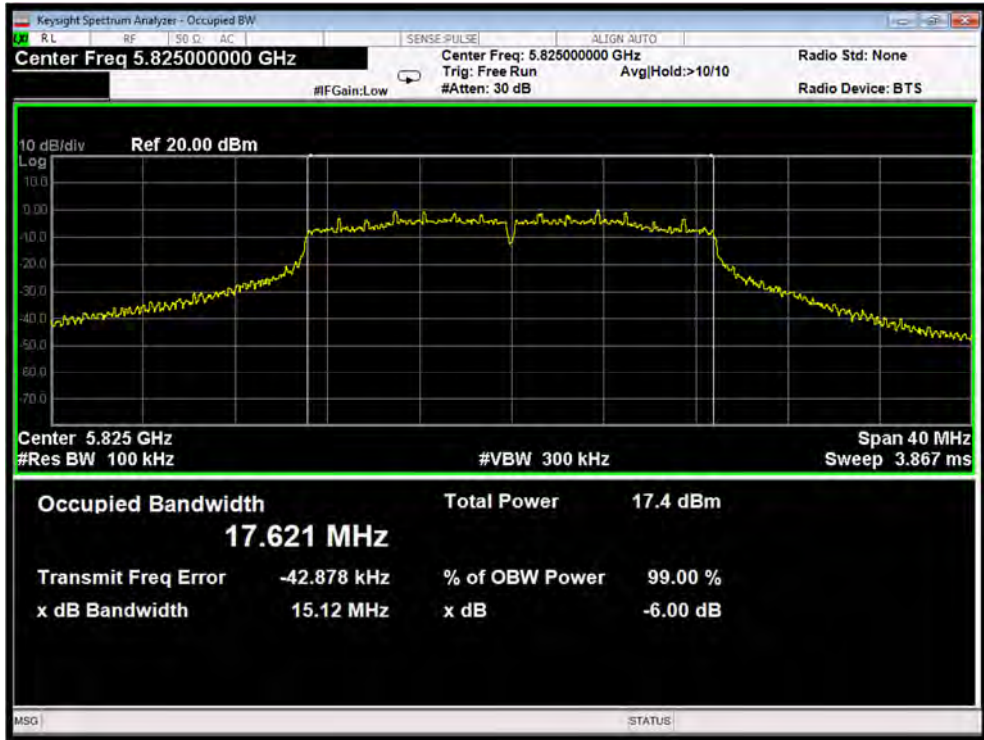

Test Mode: 802.11n20---High

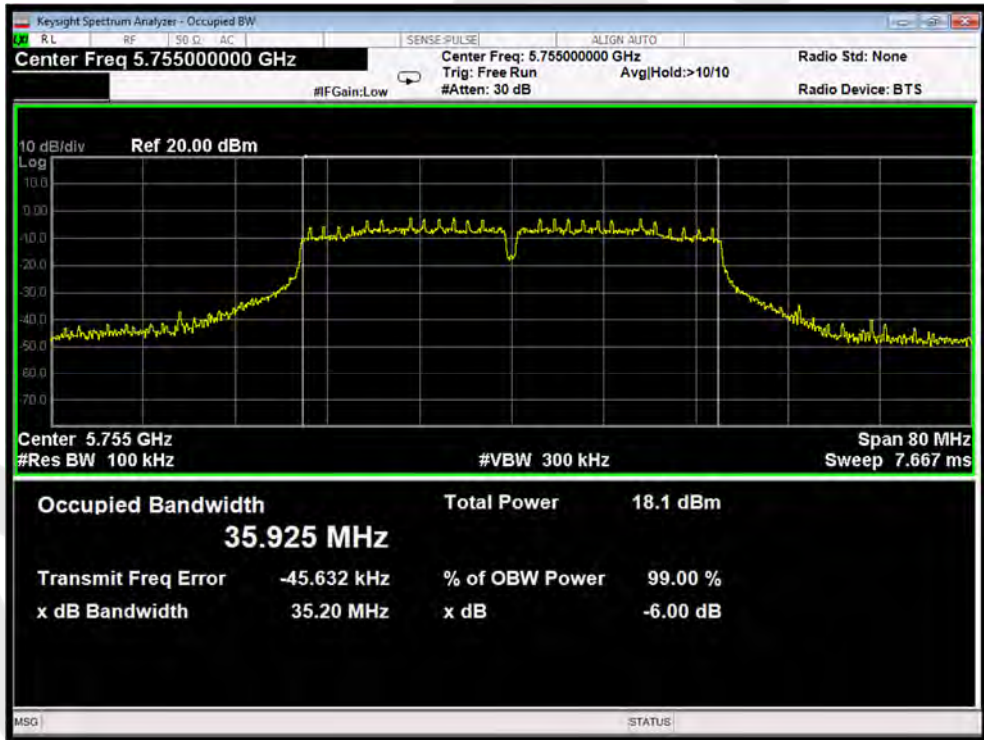

Test Mode: 802.11n40---Low



Test Mode: 802.11n40---High

26dB & 99% Bandwidth

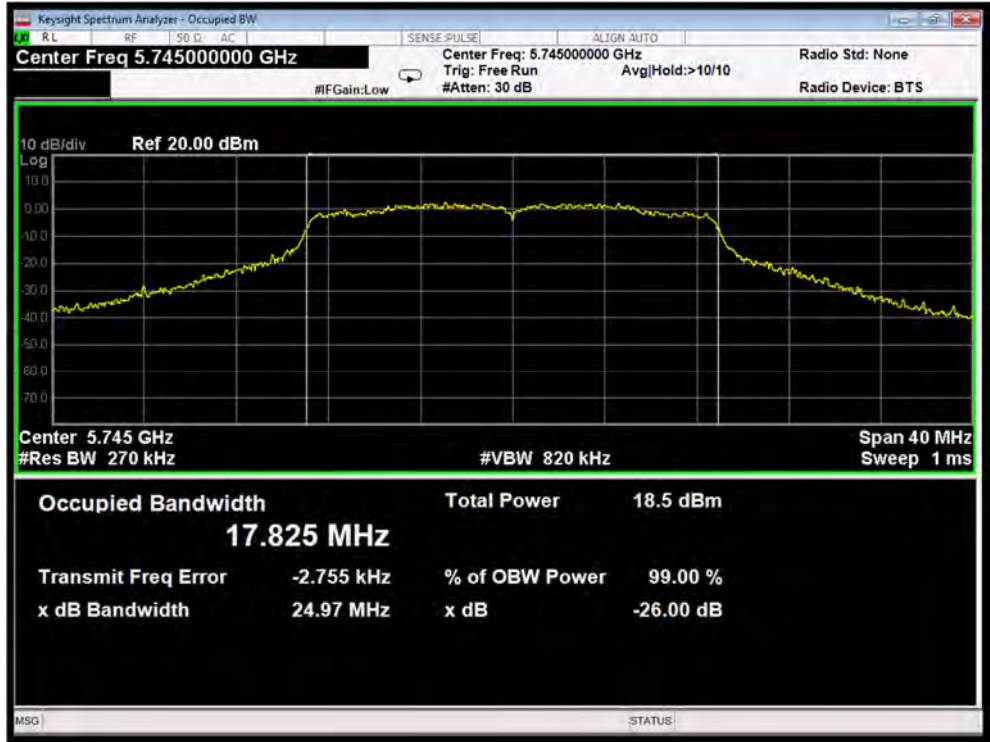

Test Mode: 802.11n20---Low

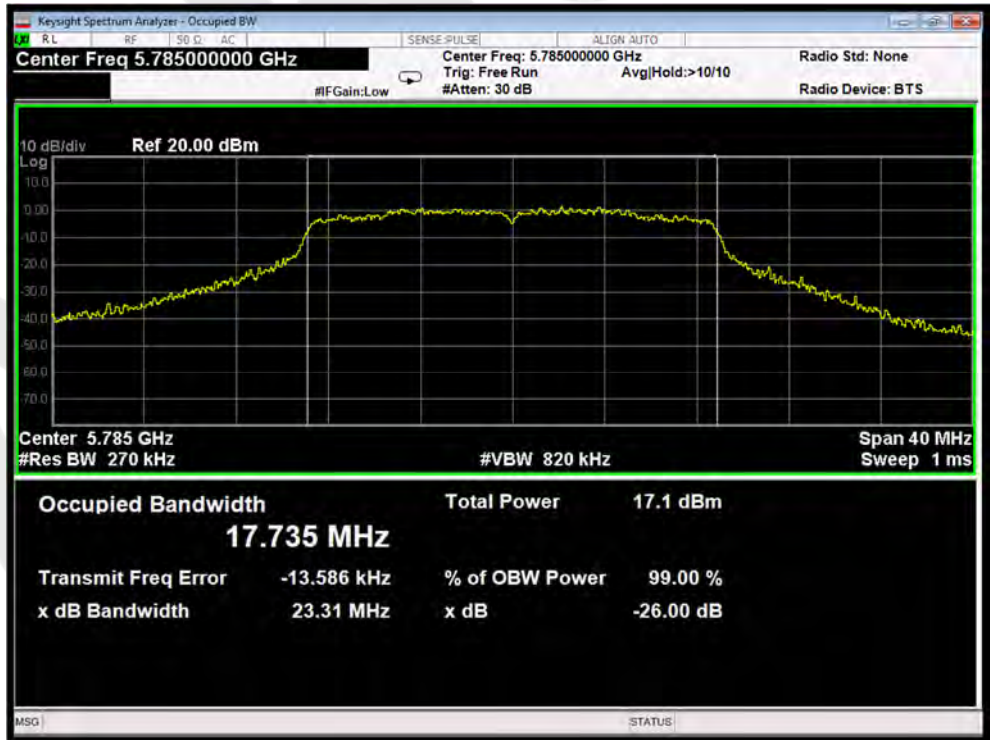

Test Mode: 802.11n20---Middle

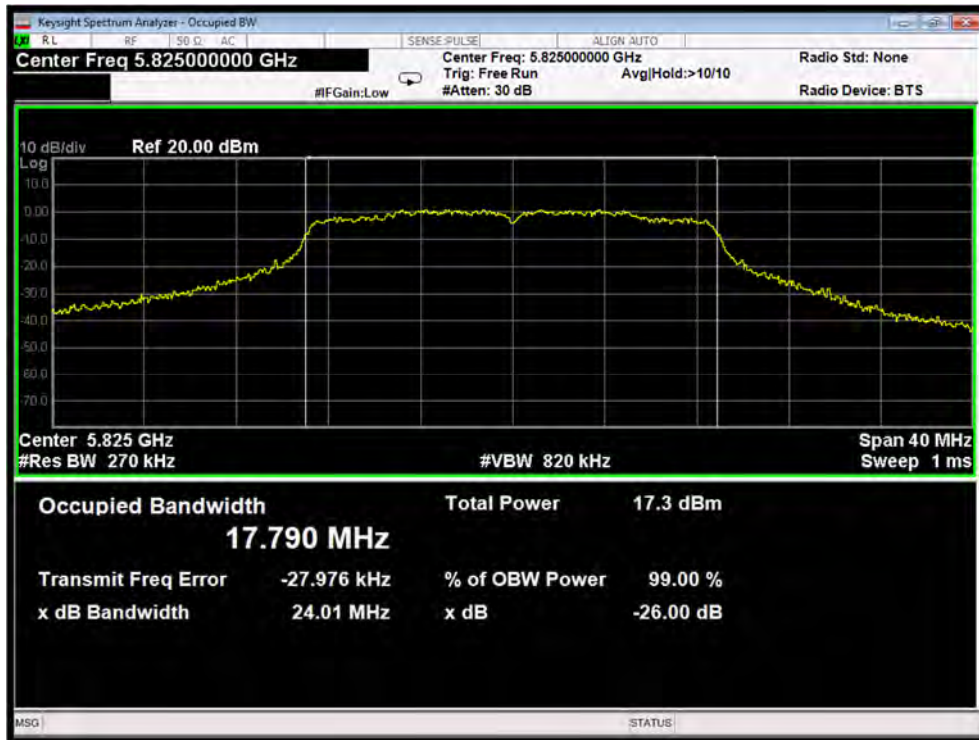

Test Mode: 802.11n20---High

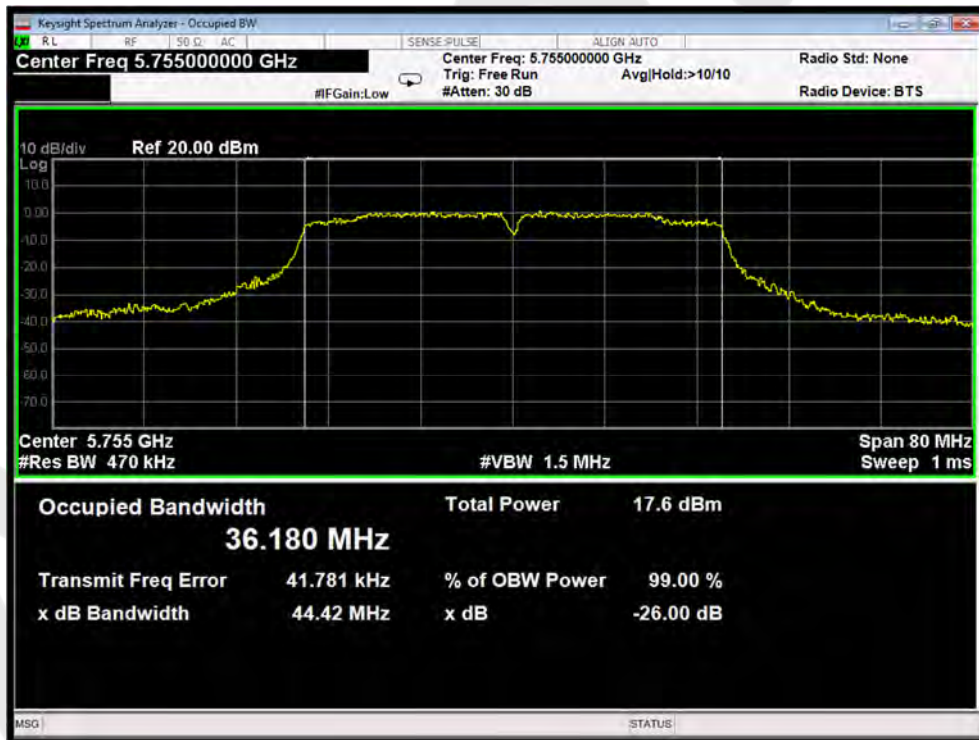

Test Mode: 802.11n40---Low

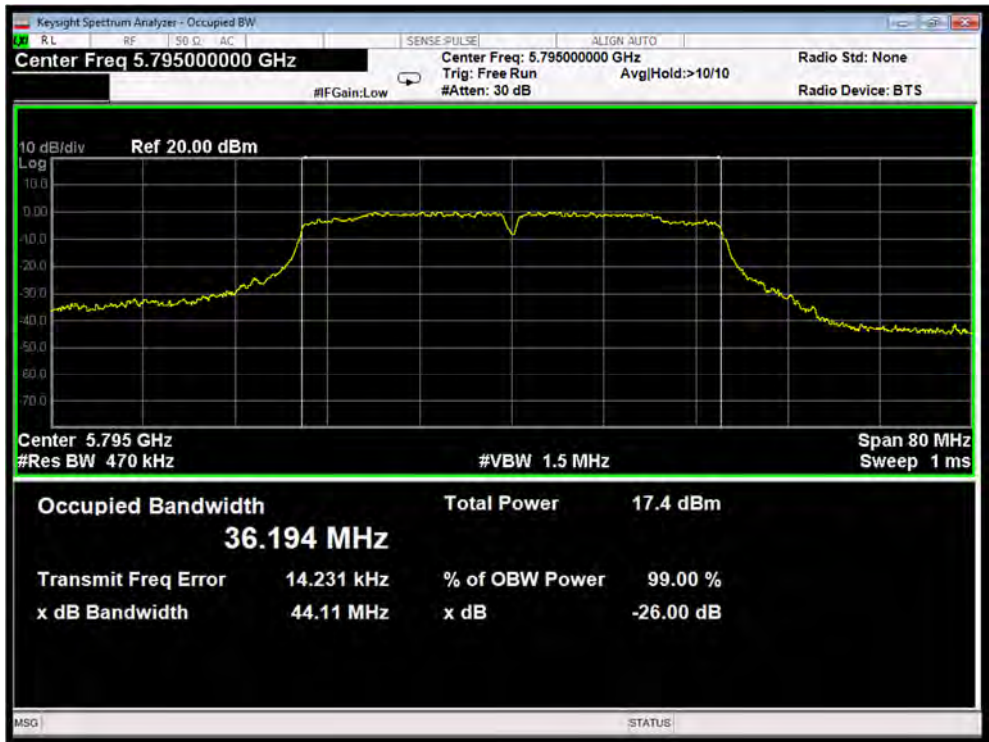

Test Mode: 802.11n40---High

6dB Bandwidth

ANT 2

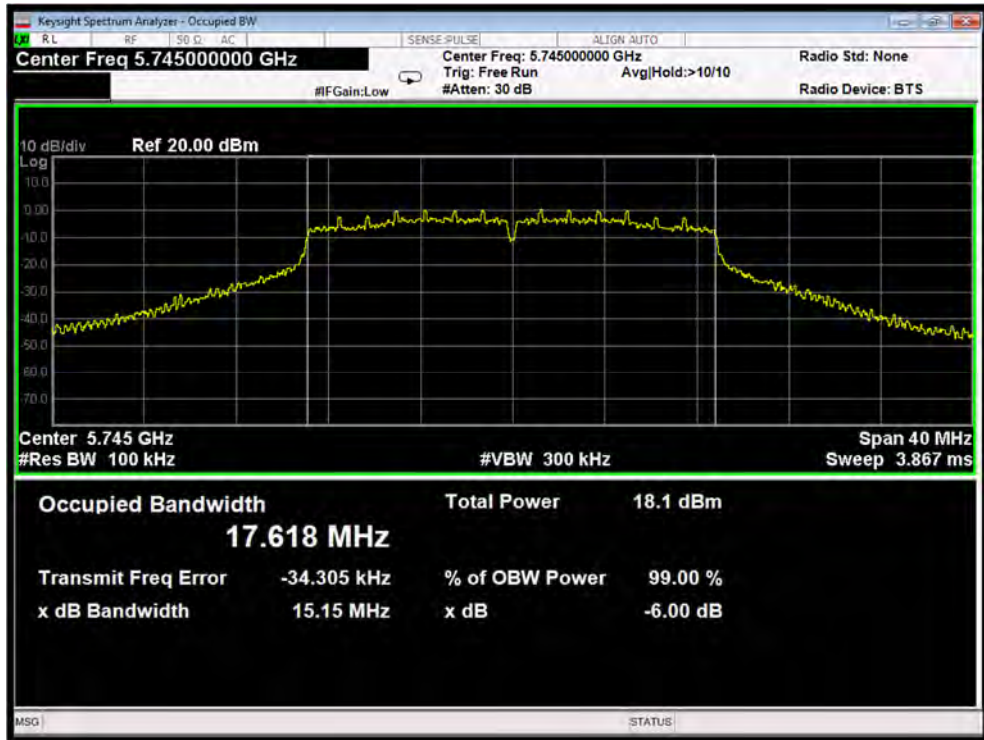

Test Mode: 802.11n20---Low

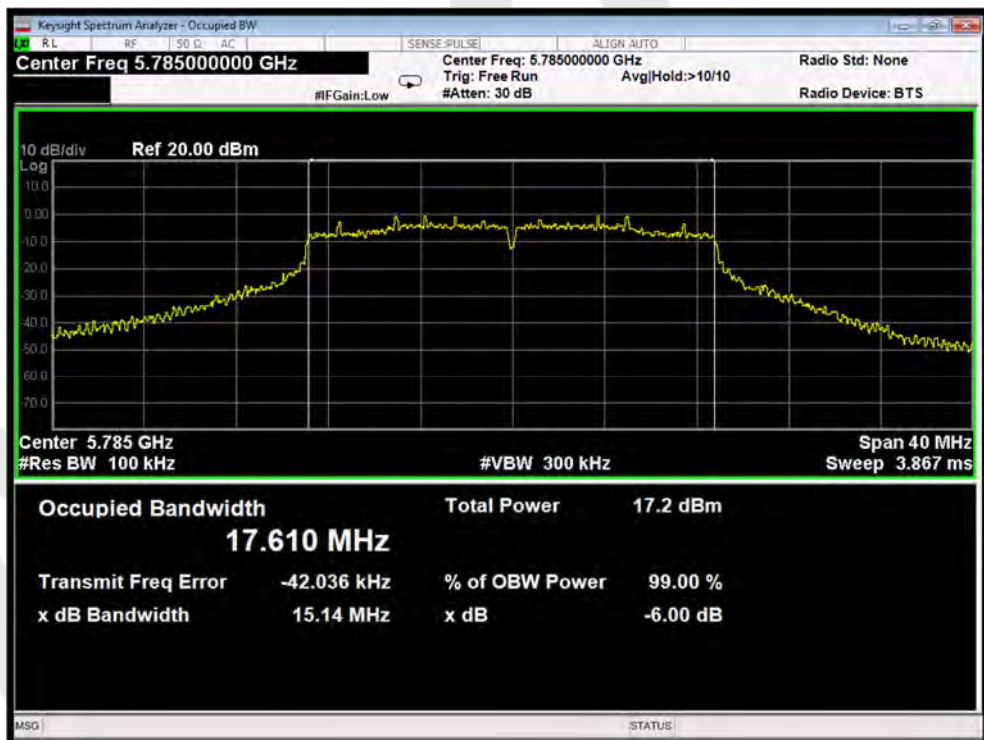

Test Mode: 802.11n20---Middle



Test Mode: 802.11n20---High

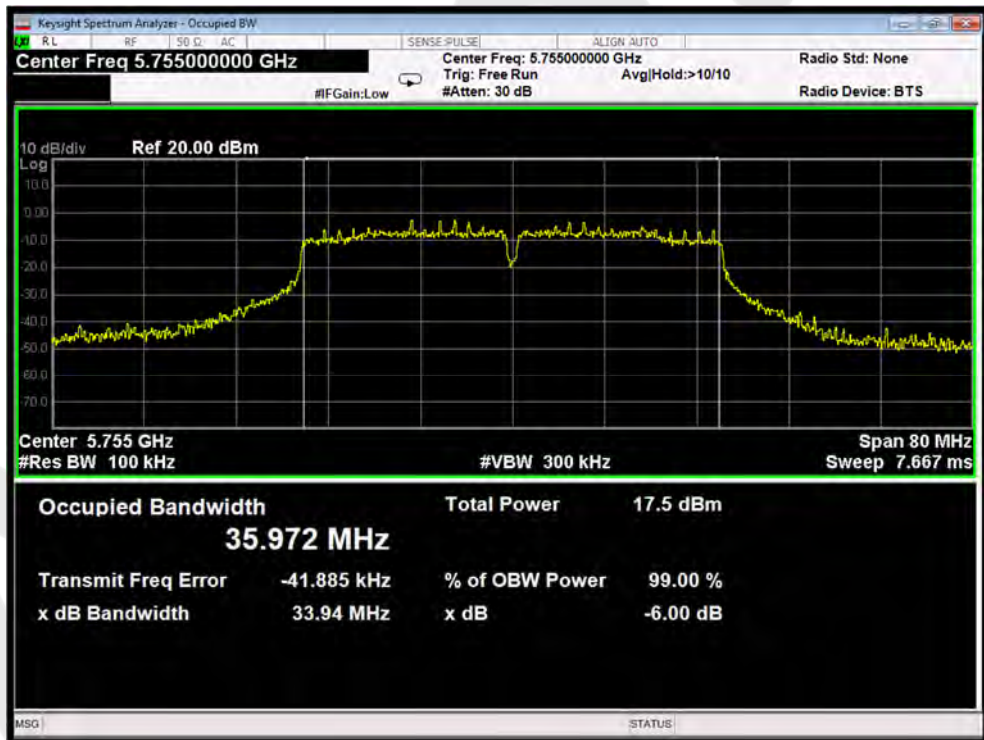

Test Mode: 802.11n40---Low



Test Mode: 802.11n40---High

26dB & 99% Bandwidth



Test Mode: 802.11n20---Low

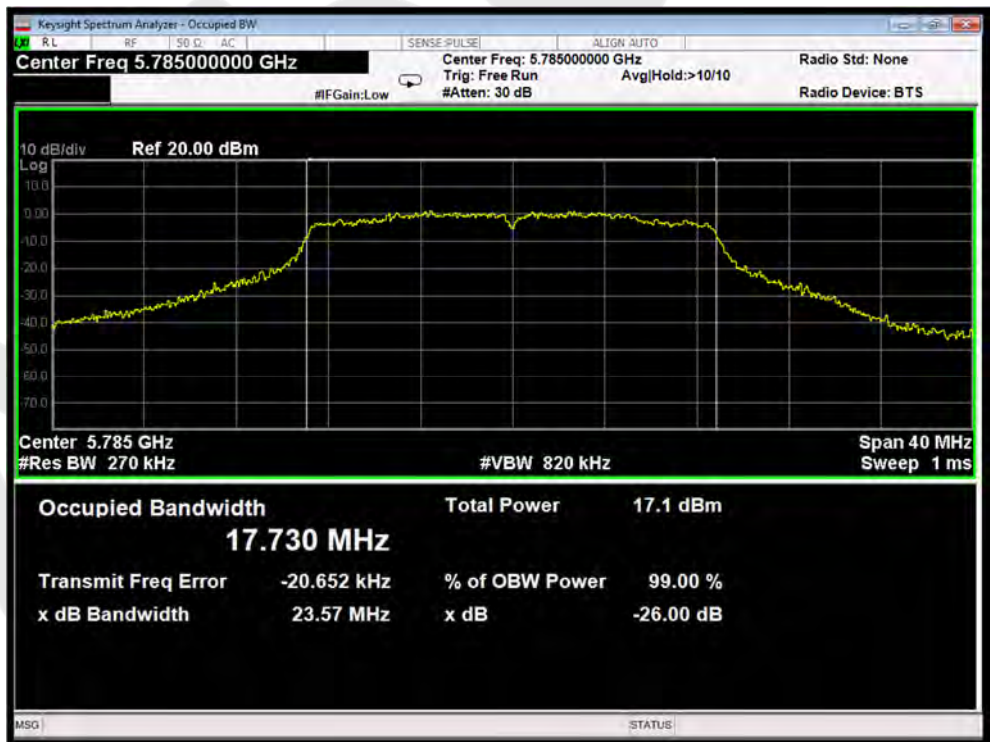

Test Mode: 802.11n20---Middle

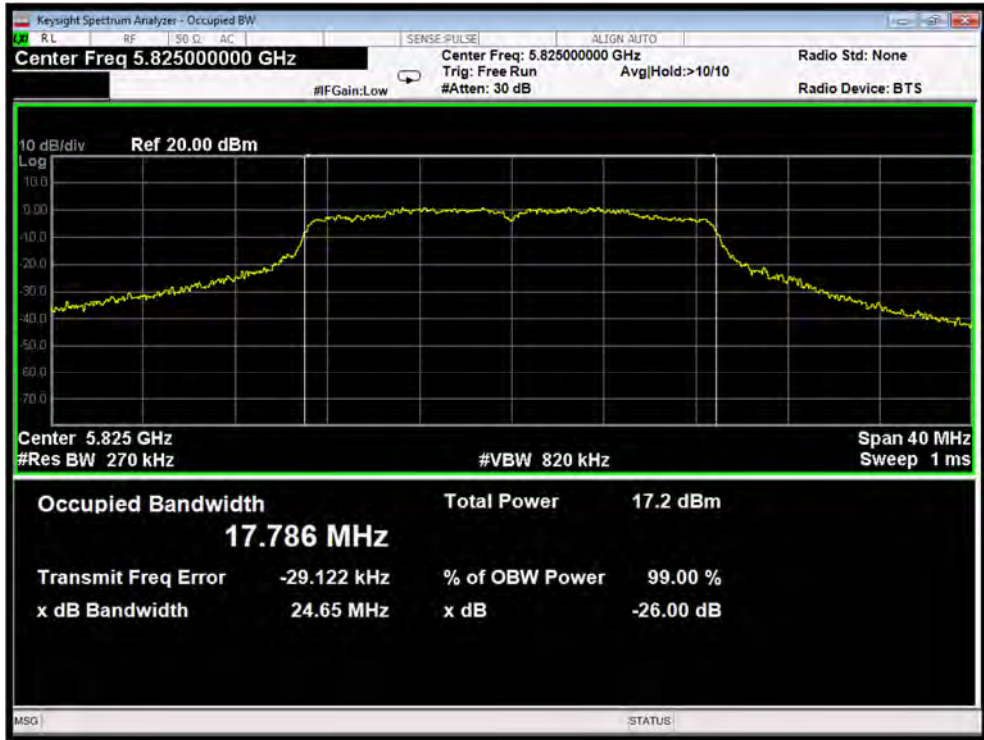

Test Mode: 802.11n20---High

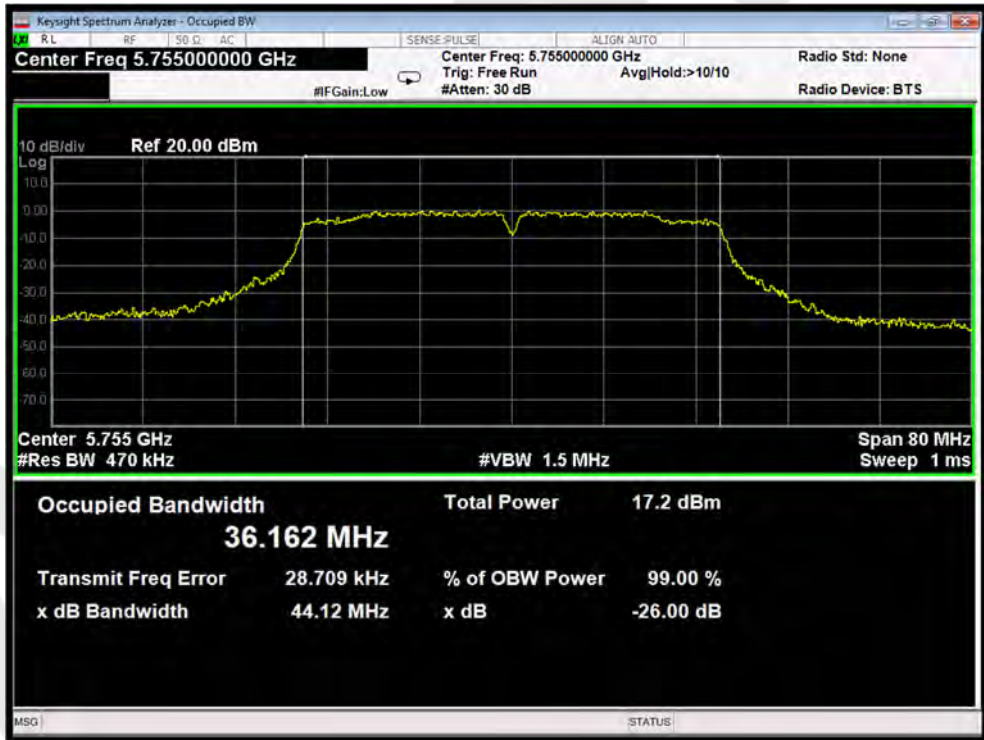

Test Mode: 802.11n40---Low

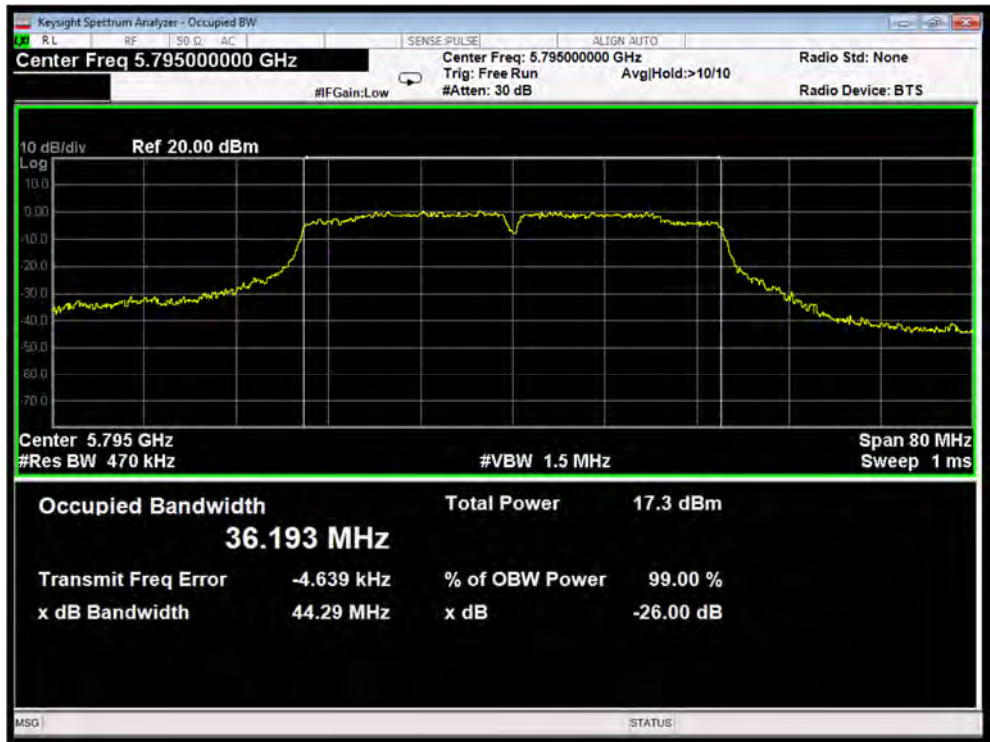

Test Mode: 802.11n40---High

7. Power Spectral Density Test

7.1. Test Standard and Limit

Test Standard	FCC Part15 C Section 15.407 (a) (3)
Test Limit	not exceed 30dBm/500kHz

7.2. Test Setup

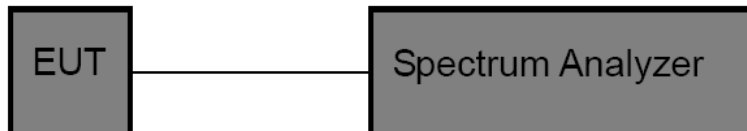

7.3. Test Procedure

For devices operating in the bands 5.15-5.25 GHz, 5.25-5.35 GHz, and 5.47-5.725 GHz, the above procedures make use of 1 MHz RBW to satisfy directly the 1 MHz reference bandwidth specified in § 15.407(a)(5). For devices operating in the band 5.725-5.85 GHz, the rules specify a measurement bandwidth of 500 kHz. Many spectrum analyzers do not have 500 kHz RBW, thus a narrower RBW may need to be used. The rules permit the use of a RBWs less than 1 MHz, or 500 kHz, “provided that the measured power is integrated over the full reference bandwidth” to show the total power over the specified measurement bandwidth (i.e., 1 MHz, or 500 kHz).

1. The EUT is directly connected to the spectrum analyzer;
2. Set RBW =510KHz;
3. Set VBW \geq 3 RBW;
3. Set the span to encompass the entire emissions bandwidth (EBW) of the signal;
5. Detector=RMS;
6. Sweep time= auto couple;
7. Trace mode=max. hold;

7.4. Test Data

Test Item	: Power Spectral Density	Test Mode	: CH Low ~ CH High
Test Voltage	: AC 120V/60HZ	Temperature	: 24°C
Test Result	: PASS	Humidity	: 55%RH

Test Mode	Channel Frequency (MHz)	Final Power Spectral Density (dBm)			Correctional Limit	Results
		ANT1	ANT2	SUM		
802.11n20	5745	5.426	5.544	8.50	25.9dBm/ 500KHz	PASS
	5785	4.496	5.859	8.24		PASS
	5825	3.777	5.108	7.50		PASS
802.11n40	5755	1.165	1.161	4.17		PASS
	5795	1.170	1.546	3.01		PASS

Note:

Directional gain=GANT +10log(N)dB_i =7+10log2=10.1dB_i

PSD limit Reduction=10.1-6=4.1dB_i

Correctional limit=30-4.1=25.9dB_i

ANT 1

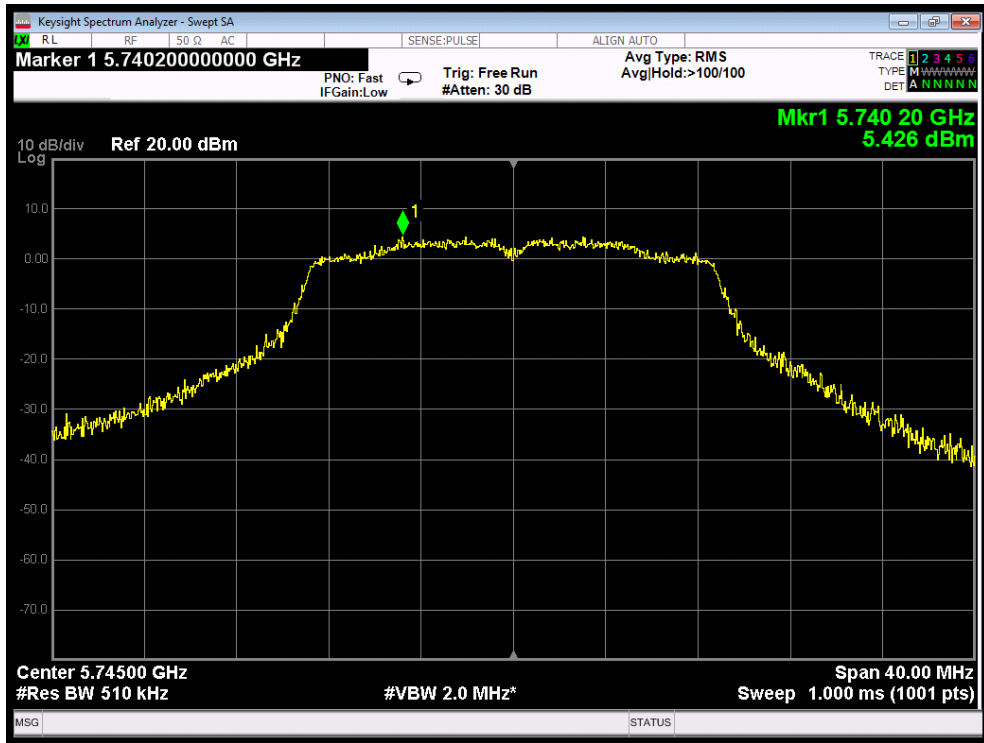

Test Mode: 802.11n20---Low

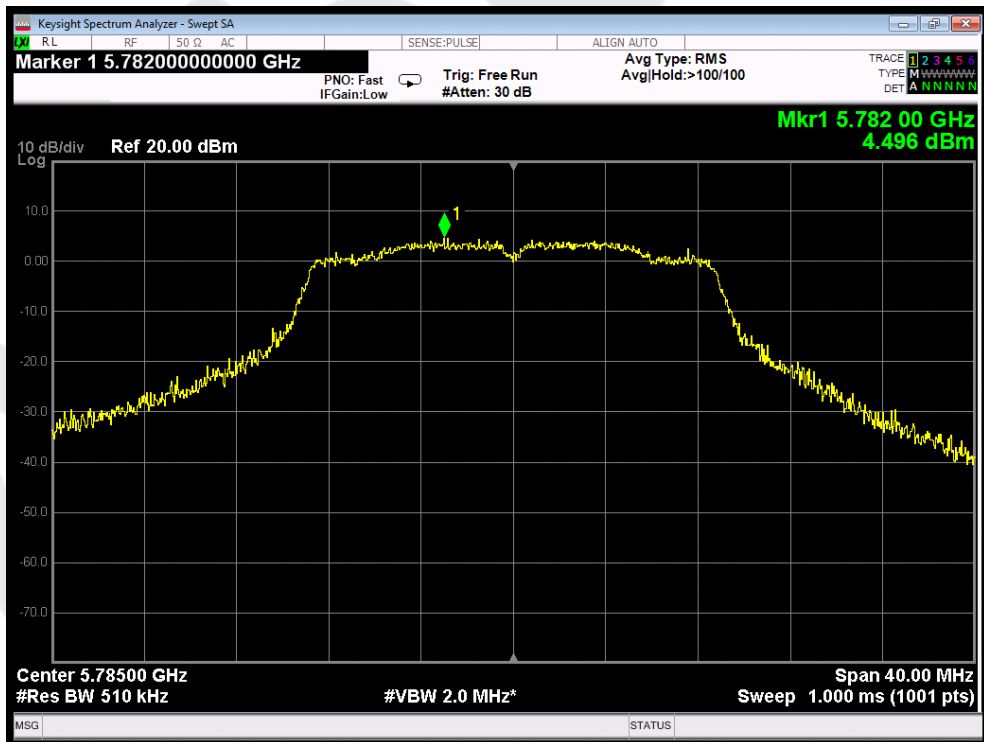

Test Mode: 802.11n20---Middle

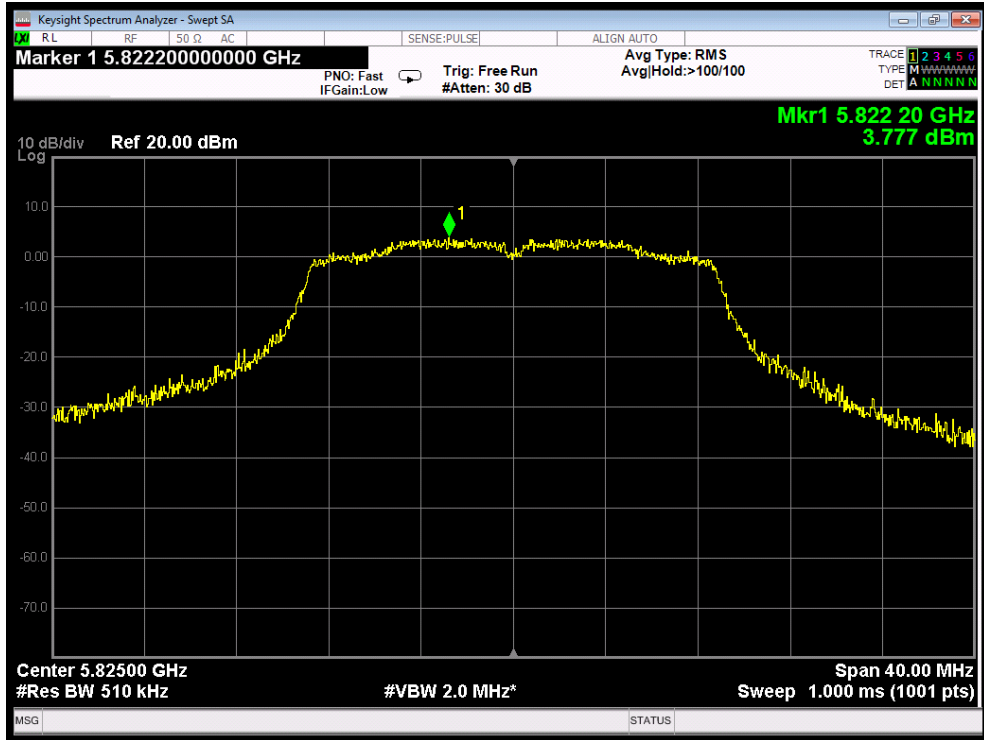

Test Mode: 802.11n20---High

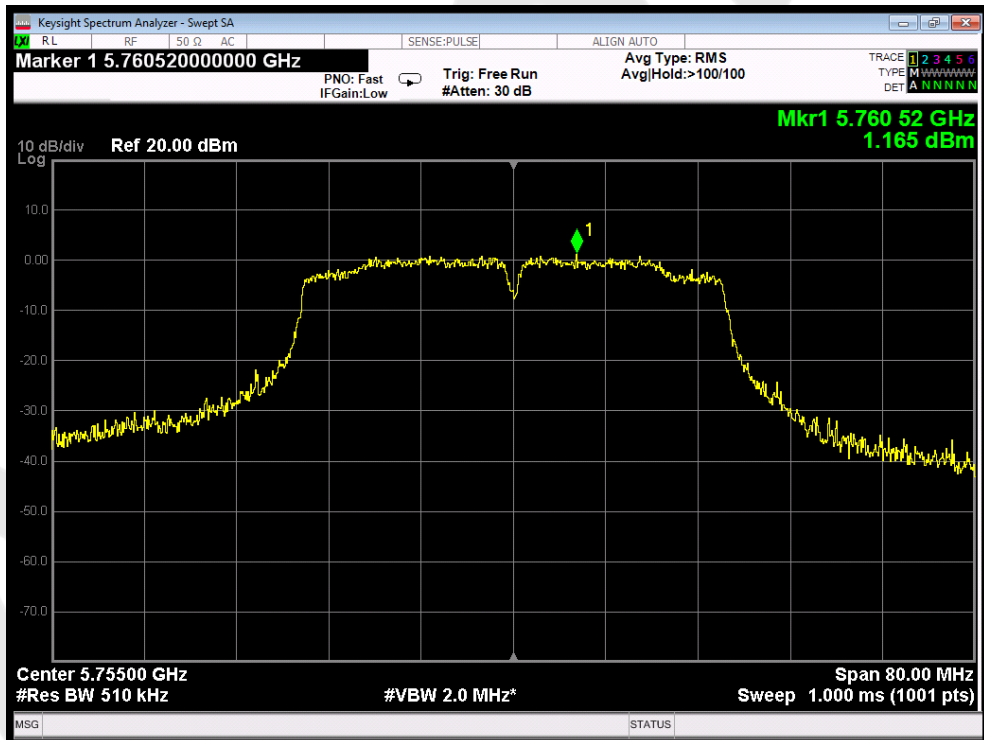

Test Mode: 802.11n40---Low

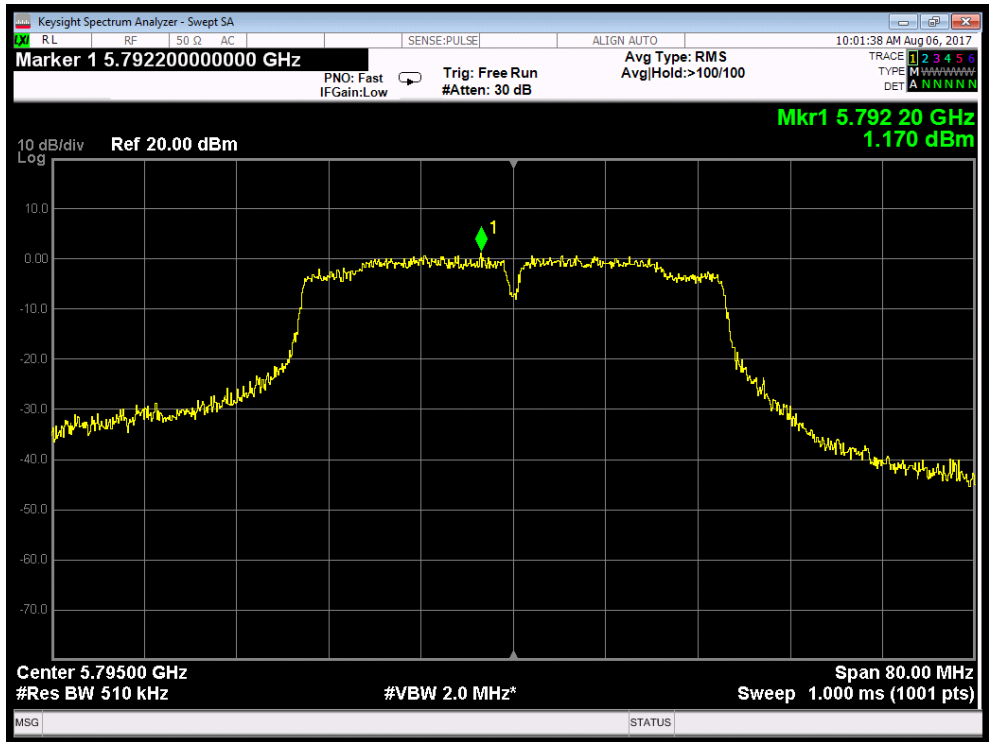

Test Mode: 802.11n40---High

ANT 2

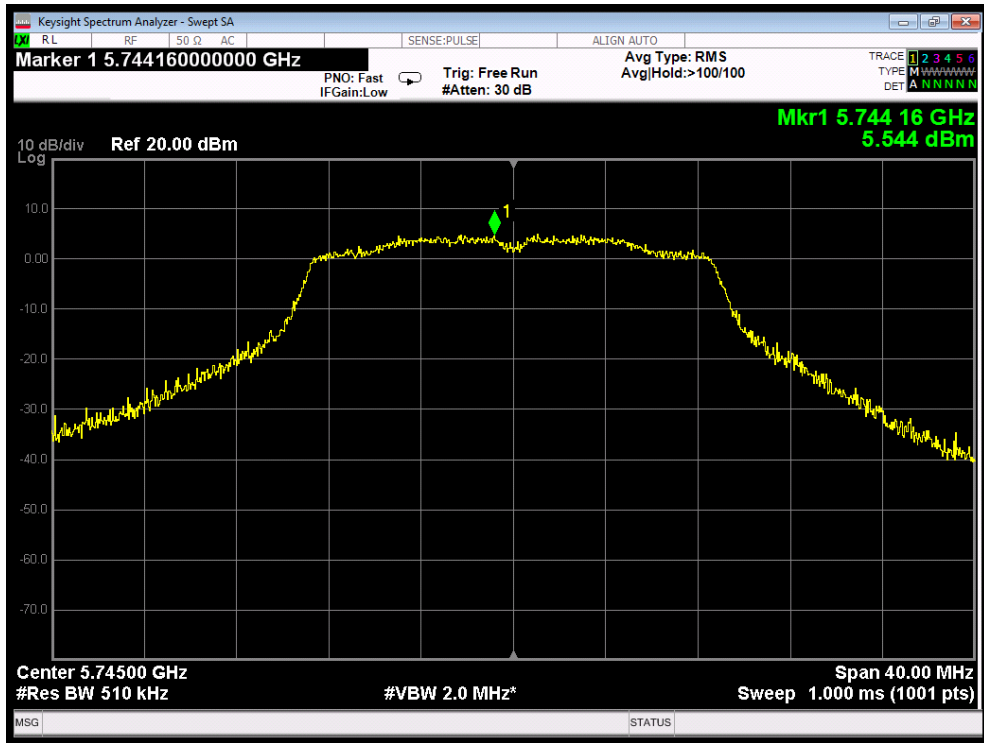

Test Mode: 802.11n20---Low

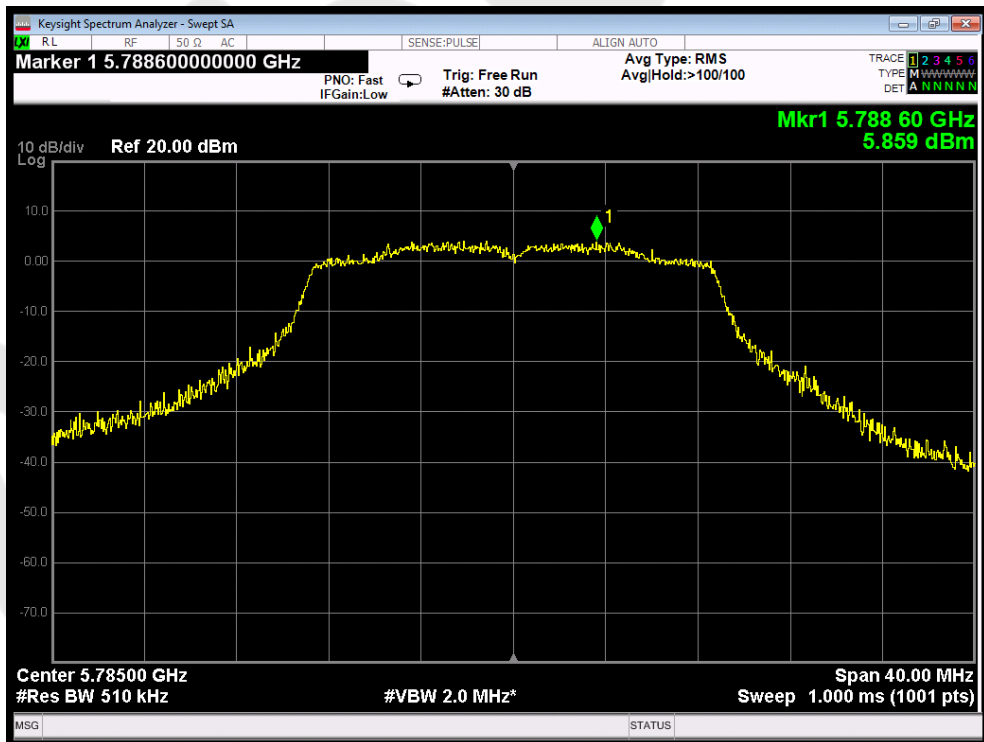

Test Mode: 802.11n20---Middle

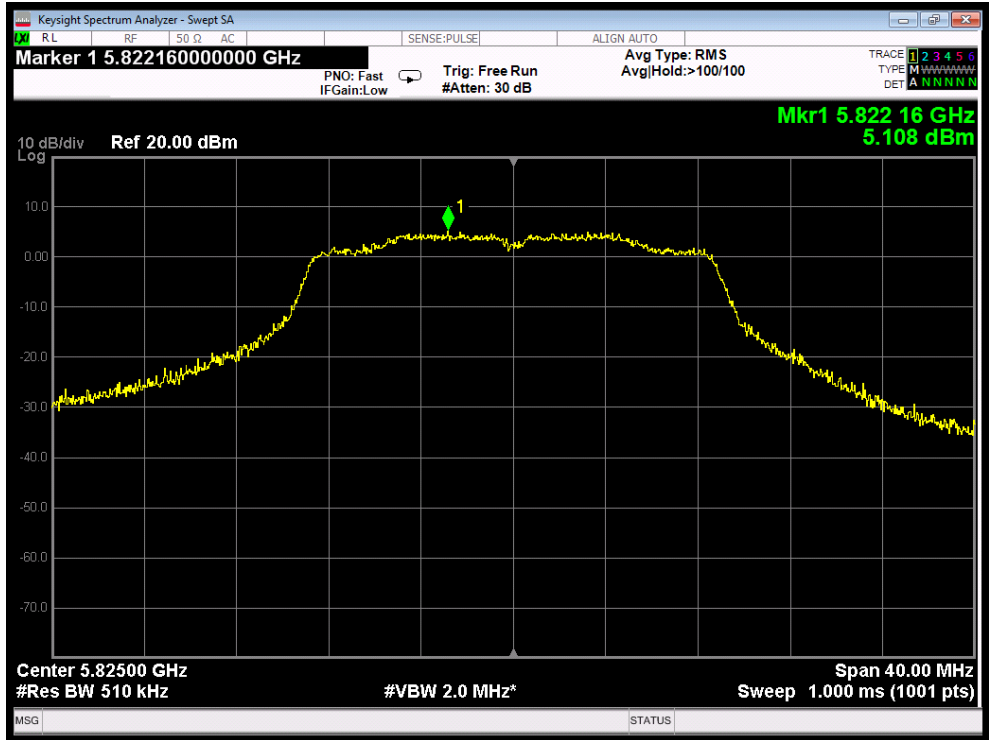

Test Mode: 802.11n20---High

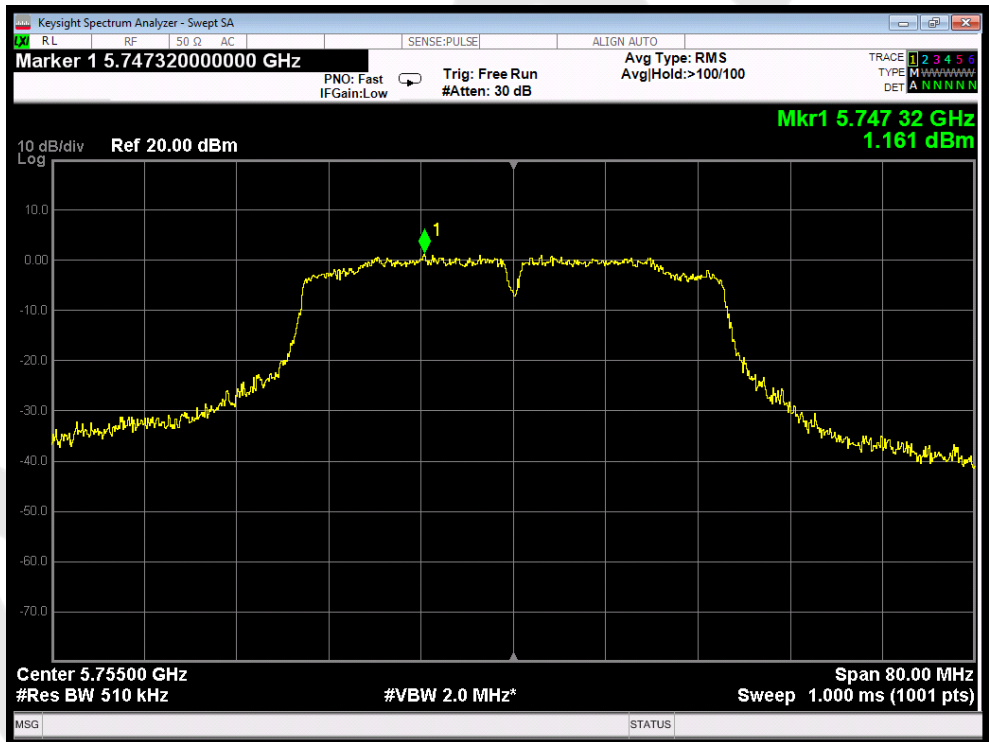

Test Mode: 802.11n40---Low

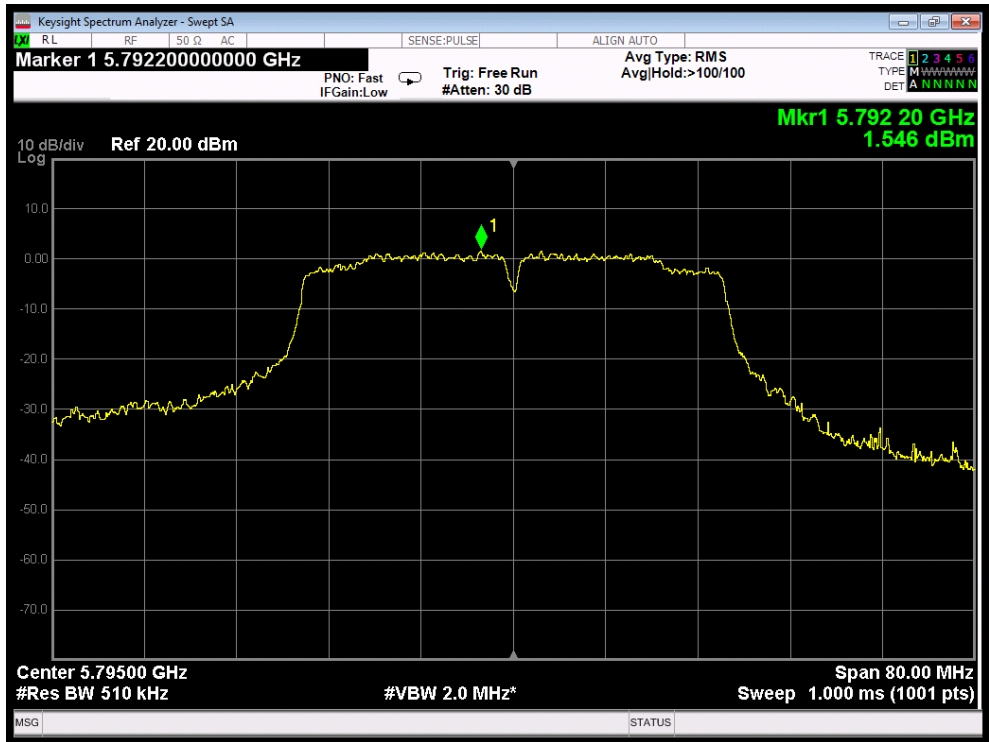

Test Mode: 802.11n40---High

8. Antenna Requirement

8.1. Test Standard and Requirement

Test Standard	FCC Part15 Section 15.203 /15.407
Requirement	<p>1) 15.203 requirement: An intentional radiator shall be designed to ensure that no antenna other than that furnished by the responsible party shall be used with the device. The use of a permanently attached antenna or of an antenna that uses a unique coupling to the intentional radiator, the manufacturer may design the unit so that a broken antenna can be replaced by the user, but the use of a standard antenna jack or electrical connector is prohibited.</p> <p>2) 15.407 requirement: An intentional radiator shall be designed to ensure that no antenna other than that furnished by the responsible party shall be used with the device. The use of a permanently attached antenna or of an antenna that uses a unique coupling to the intentional radiator shall be considered sufficient to comply with the provisions of this section. The manufacturer may design the unit so that a broken antenna can be replaced by the user, but the use of a standard antenna jack or electrical connector is prohibited. This requirement does not apply to carrier current devices or to devices operated under the provisions of §15.211, §15.213, §15.217, §15.219, or §15.221. Further, this requirement does not apply to intentional radiators that must be professionally installed, such as perimeter protection systems and some field disturbance sensors, or to other intentional radiators which, in accordance with §15.31(d), must be measured at the installation site. However, the installer shall be responsible for ensuring that the proper antenna is employed so that the limits in this part are not exceeded.</p>

8.2. Antenna Connected Construction

The WIFI antenna is a Columnar Antenna which permanently attached, and the best case gain of the antenna is 7 dBi each antenna(It is reduced power treatment). It complies with the standard requirement.

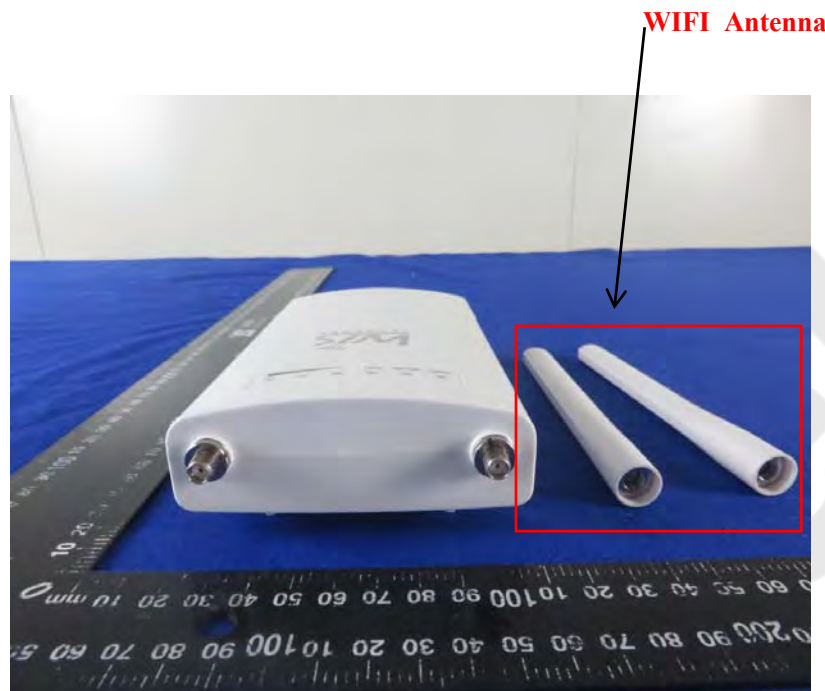

APPENDIX I -- TEST SETUP PHOTOGRAPH

Photo of Conducted Emission Measurement



Photo of Radiation Emission Test

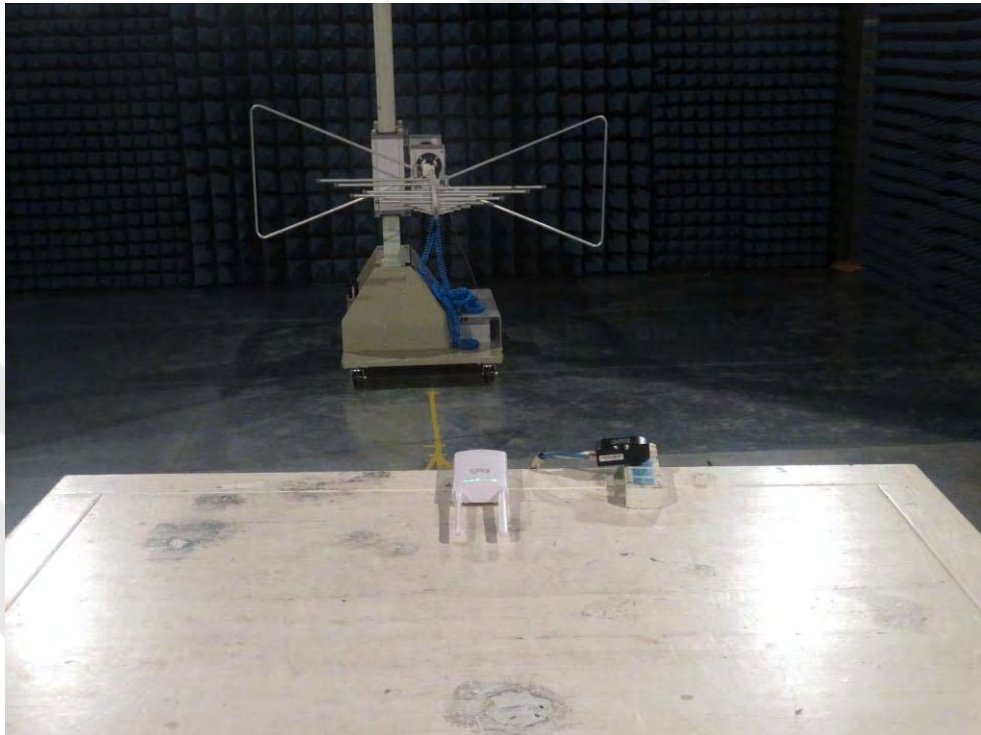

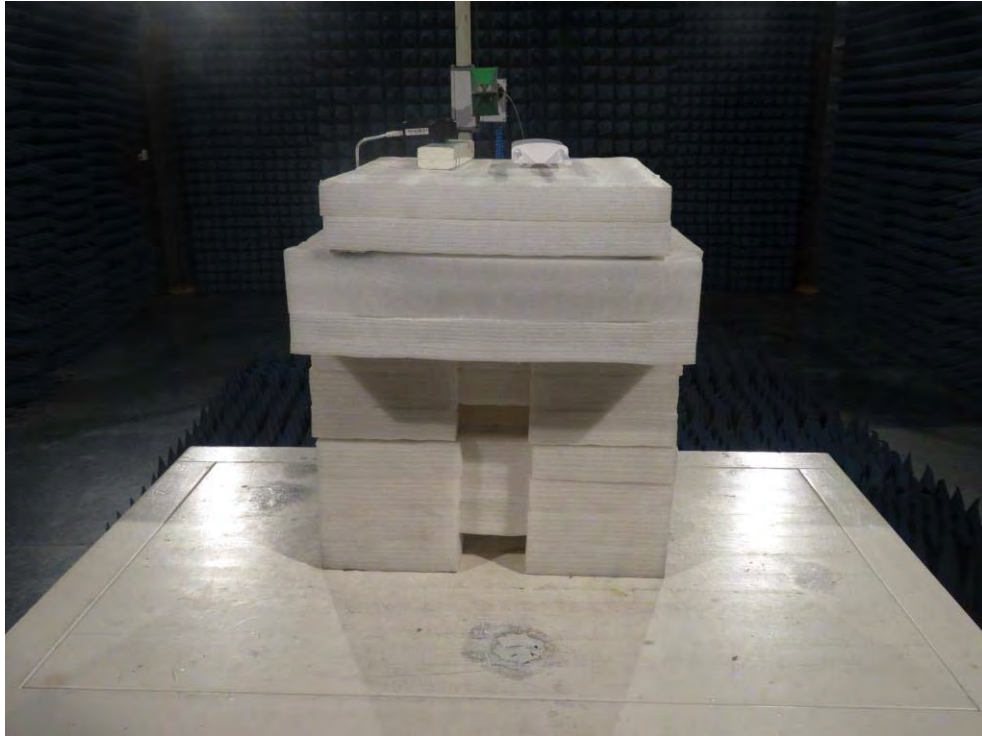

APPENDIX II -- EXTERNAL PHOTOGRAPH





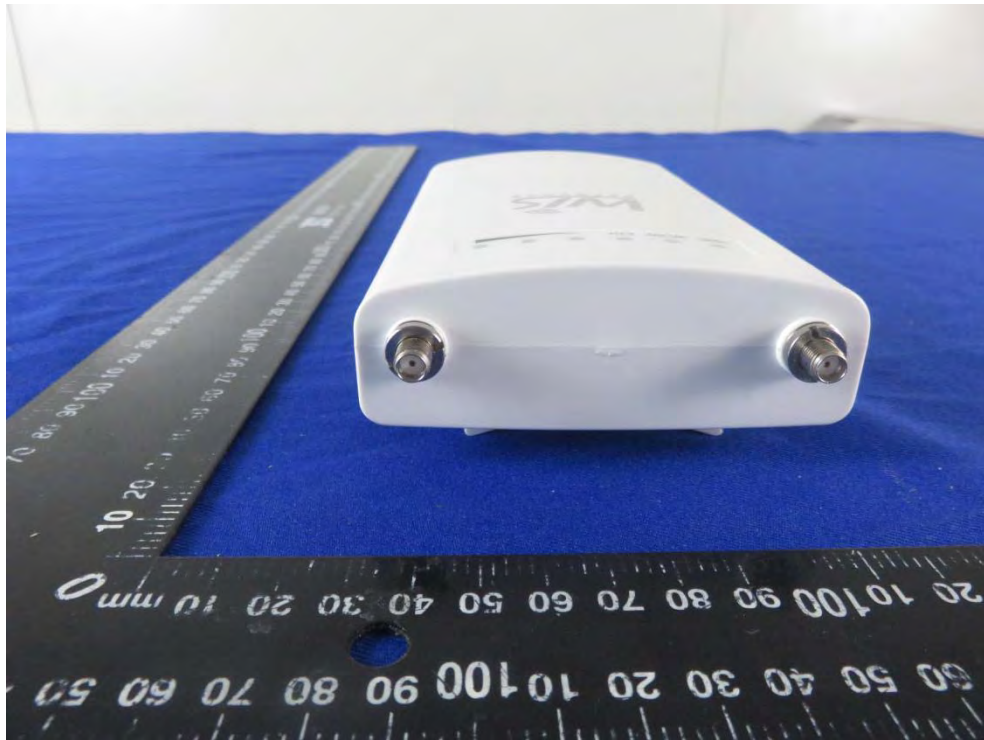



APPENDIX III -- INTERNAL PHOTOGRAPH



