

# FCC TEST REPORT

For

WISNETWORKS Technology Co., Ltd

Smart Wireless Router

Model No.: AirMesh

Prepared For : WISNETWORKS Technology Co., Ltd  
Address : No.77, FuTe West 3 Road, Pilot Free Trade Zone, Shanghai, China

Prepared By : Shenzhen Anbotek Compliance Laboratory Limited  
Address : 1/F., Building 1, SEC Industrial Park, No.0409 Qianhai Road, Nanshan District, Shenzhen, Guangdong, China  
Tel: (86) 755-26066544 Fax: (86) 755-26014772

Report Number : R0217060259W2  
Date of Test : Jun. 08~Jul. 10, 2017  
Date of Report : Jul. 10, 2017

# Contents

1. General Information.....	4
1.1. Client Information.....	4
1.2. Description of Device (EUT).....	4
1.3. Auxiliary Equipment Used During Test.....	5
1.4. Description of Test Modes.....	6
1.5. List of channels.....	7
1.6. Description Of Test Setup.....	8
1.7. Test Equipment List.....	9
1.8. Measurement Uncertainty.....	10
1.9. Description of Test Facility.....	10
2. Summary of Test Results.....	11
3. Conducted Emission Test.....	12
3.1. Test Standard and Limit.....	12
3.2. Test Setup.....	12
3.3. Test Procedure.....	12
3.4. Test Data.....	12
4. Radiation Spurious Emission and Band Edge.....	17
4.1. Test Standard and Limit.....	17
4.2. Test Setup.....	18
4.3. Test Procedure.....	19
4.4. Test Data.....	19
5. Maximum Peak Output Power Test.....	47
5.1. Test Standard and Limit.....	47
5.2. Test Setup.....	47
5.3. Test Procedure.....	47
5.4. Test Data.....	47
6. Occupy Bandwidth Test.....	49
6.1. Test Standard.....	49
6.2. Test Setup.....	49
6.3. Test Procedure.....	49
6.4. Test Data.....	49
7. Power Spectral Density Test.....	80
7.1. Test Standard and Limit.....	80
7.2. Test Setup.....	80
7.3. Test Procedure.....	80
7.4. Test Data.....	80
8. Antenna Requirement.....	97
8.1. Test Standard and Requirement.....	97
8.2. Antenna Connected Construction.....	98
APPENDIX I -- TEST SETUP PHOTOGRAPH.....	99
APPENDIX II -- EXTERNAL PHOTOGRAPH.....	101
APPENDIX III -- INTERNAL PHOTOGRAPH.....	105

# TEST REPORT

Applicant : WISNETWORKS Technology Co., Ltd  
Manufacturer : WISNETWORKS Technology Co., Ltd  
Product Name : Smart Wireless Router  
Model No. : AirMesh  
Trade Mark : N.A.  
Rating(s) : Input DC 12V 1A (Via adapter AC 100-240V, 50/60HZ, 0.5A)

**Test Standard(s) : FCC Part15 Subpart E 2016, Paragraph 15.407**  
**ANSI C63.10: 2013**  
**Test Method(s) : KDB 789033 D02 General UNII Test Procedures New Rules v01r04**

The device described above is tested by Shenzhen Anbotek Compliance Laboratory Limited to determine the maximum emission levels emanating from the device and the severe levels of the device can endure and its performance criterion. The measurement results are contained in this test report and Shenzhen Anbotek Compliance Laboratory Limited is assumed full of responsibility for the accuracy and completeness of these measurements. Also, this report shows that the EUT (Equipment Under Test) is technically compliant with the FCC Part 15 Subpart E requirements.

This report applies to above tested sample only and shall not be reproduced in part without written approval of Shenzhen Anbotek Compliance Laboratory Limited.

Date of Test : Jun. 08~Jul. 10, 2017

Prepared by :



*Winkey Wang*

(Tested Engineer / Winkey Wang)

Reviewer :

*Tangcy. T.*

(Project Manager / Tangcy. T)

Approved & Authorized Signer :

*Tom Chen*

(Manager / Tom Chen)

# 1. General Information

## 1.1. Client Information

Applicant	:	WISNETWORKS Technology Co., Ltd
Address	:	No.77, FuTe West 3 Road, Pilot Free Trade Zone, Shanghai, China
Manufacturer	:	WISNETWORKS Technology Co., Ltd
Address	:	No.77, FuTe West 3 Road, Pilot Free Trade Zone, Shanghai, China

## 1.2. Description of Device (EUT)

Product Name	:	Smart Wireless Router	
Model No.	:	AirMesh	
Trade Mark	:	N.A	
Test Power Supply	:	AC 120V, 60Hz for adapter/AC 240V, 60Hz for adapter	
Product Description	:	Operation Frequency:	WIFI 5G: 5745MHz~5825MHz / 5755MHz~5795MHz/ 5775MHz
		Number of Channel:	WIFI 5G: 5 Channels for 802.11a 5 Channels for 802.11n(HT20) 5 Channels for 802.11ac(HT20) 2 Channels for 802.11n(HT40) 2 Channels for 802.11ac(HT40) 1 Channels for 802.11ac(HT80)
		Modulation Type:	OFDM with BPSK/QPSK/16QAM/64QAM for 802.11a/b/g/n; OFDM with BPSK/QPSK/16QAM/64QAM/ 256QAM for 802.11ac
		Antenna Type:	Internal antenna 2X2 MIMO
		Antenna Gain(Peak):	5G WIFI ANT 1: 7dBi 5G WIFI ANT 2: 7dBi

**Remark:** 1) For a more detailed features description, please refer to the manufacturer's specifications or the User's Manual.  
 2) This report is for WIFI 5G  
 3) For 802.11 802.11 n/802.11ac mode, directional gain=GANT +10log(N)dBi =10.1dBi

### 1.3. Auxiliary Equipment Used During Test

Adapter	:	M/N: HS36-1201000CH Input: 100-240V~50/60Hz 0.5A Max Output: DC 12V, 1A Remark: The adapter was provided by customer.
PC	:	Manufacturer: DELL
		M/N: Optiplex 3020 MT S/N: CN-079V51-70163-4AD-089K-A00 Input Rating: AC 100-240V, 50-60Hz 5.4A CE , FCC DOC, CCC
MONITOR	:	Manufacturer: DELL
		M/N: UZ2215Hf S/N: CN-035VN6-72872-45A-A3AB Input Rating: AC 100-240V, 50-60Hz, 1.5A Output Rating: DC 19.5V, 4.62A TUV-GS FCC CE KCC VCCI
KEYBOARD	:	Manufacturer: DELL
		M/N: SK-8120 S/N: CN-0DJ365-71616-49J-0MVR-A00 Input Rating: DC 5V,0.05A CE FCC VCCI KCC TUV-GS Cable: 1.8m, unshielded
MOUSE	:	Manufacturer: DELL
		M/N: MS111-T S/N: CN-0KW2YH-71616-488-1CBJ Input Rating: DC 5V,0.1A Cable: 1.8m, unshielded CE FCC VCCI KCC TUV-GS

#### 1.4. Description of Test Modes

To investigate the maximum EMI emission characteristics generates from EUT, the test system was pre-scanning tested base on the consideration of following EUT operation mode or test configuration mode which possible have effect on EMI emission level. Each of these EUT operation mode(s) or test configuration mode(s) mentioned above was evaluated respectively.

Mode	Test channel	Frequency (MHz)
OFDM(802.11a/n20/ac20)	CH 149	5745MHz
	CH 157	5785MHz
	CH 165	5825MHz
OFDM(802.11n40/ac40)	CH 151	5755MHz
	CH159	5795MHz
OFDM(802.11ac80)	CH 155	5775MHz

Note:

1. The measurements are performed at the highest, middle, lowest available channels.
2. The EUT has been tested as an independent unit. And Continual Transmitting in maximum power.
3. For the relevant Conducted Measurement, the temporary antenna connector is used during the measurement. Antenna Connector Impedance: 50  $\Omega$ , Cable Loss: 1.0 dB
4. The EUT was programmed to be in continuously transmitting mode and the transmit duty cycle is more than 98%

### 1.5. List of channels

#### 802.11a/n20/ac20

Channel	Freq. (MHz)	Channel	Freq. (MHz)
149	5745	153	5765
157	5785	161	5805
165	5825		

#### 802.11n40/ac40

Channel	Freq. (MHz)	Channel	Freq. (MHz)
151	5755	159	5795

#### 802.11ac80

Channel	Freq. (MHz)
155	5775

### 1.6. Description Of Test Setup

CE

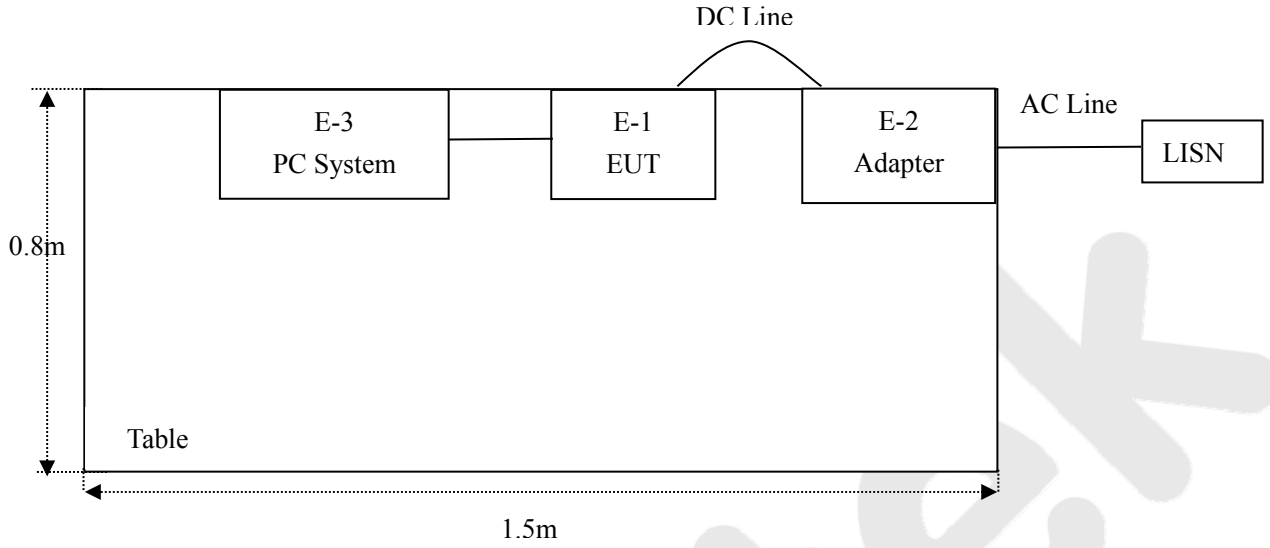

RE

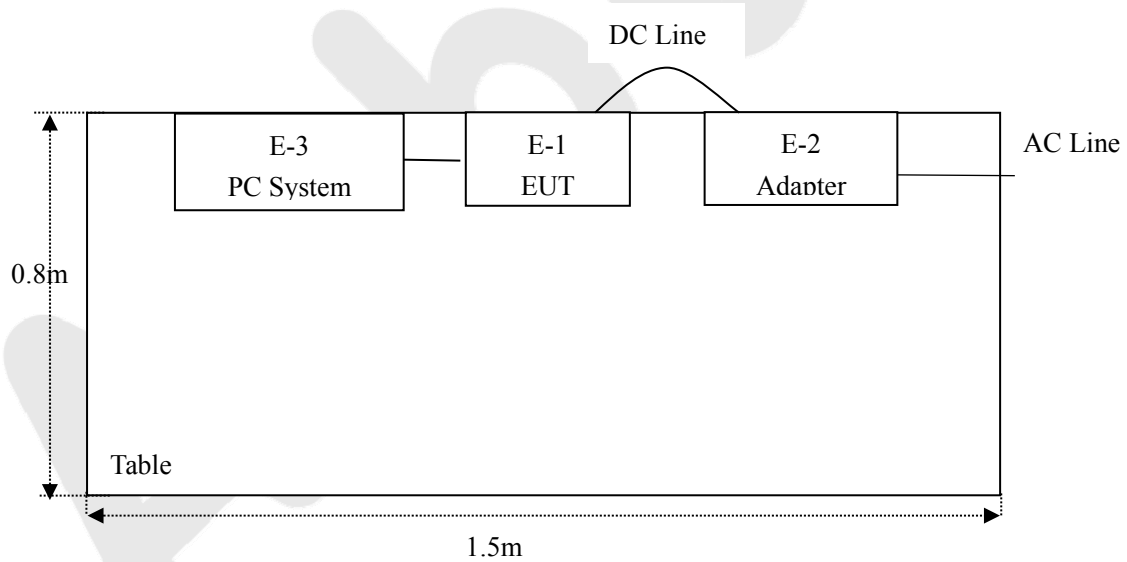



### 1.7. Test Equipment List

Item	Equipment	Manufacturer	Model No.	Serial No.	Last Cal.	Cal. Interval
1.	L.I.S.N. Artificial Mains Network	Rohde & Schwarz	ENV216	100055	May 27, 2017	1 Year
2.	EMI Test Receiver	Rohde & Schwarz	ESCI	100627	May 27, 2017	1 Year
3.	RF Switching Unit	Compliance Direction	RSU-M2	38303	May 27, 2017	1 Year
4.	Spectrum Analysis	Agilent	E4407B	US39390582	May 27, 2017	1 Year
5.	Preamplifier	SKET Electronic	BK1G18G30 D	KD17503	May 27, 2017	1 Year
6.	EMI Test Receiver	Rohde & Schwarz	ESPI	101604	May 27, 2017	1 Year
7.	Double Ridged Horn Antenna	Instruments corporation	GTH-0118	351600	May 31, 2017	1 Year
8.	Bilog Broadband Antenna	Schwarzbeck	VULB9163	VULB 9163-289	May 31, 2017	1 Year
9.	Loop Antenna	Schwarzbeck	HFH2-Z2	100047	Apr. 03, 2017	1 Year
10.	Pre-amplifier	SONOMA	310N	186860	May 27, 2017	1 Year
11.	EMI Test Software EZ-EMC	SHURPLE	N/A	N/A	N/A	N/A
12.	Power Sensor	DAER	RPR3006W	15100041SN045	May 27, 2017	1 Year
13.	Power Sensor	DAER	RPR3006W	15100041SN046	May 27, 2017	1 Year
14.	Power Meter	Agilent	N1914A	MY50001102	May 27, 2017	1 Year
15.	Power Sensor	Agilent	N8481H	MY51240001	May 27, 2017	1 Year
16.	MXA Spectrum Analysis	Agilent	N9020A	MY51170037	May 27, 2017	1 Year
17.	MXG RF Vector Signal Generator	Agilent	N5182A	MY48180656	May 27, 2017	1 Year
18.	Signal Generator	Agilent	E4421B	MY41000743	May 27, 2017	1 Year
19.	DC Power supply	IVYTECH	IV6003	1601D6030007	May 26, 2017	1 Year
20.	TEMP&HUMI PROGRAMMABLE CHAMBER	Sertep	ZJ-HWHS80 B	ZJ-17042804	Mar. 03, 2017	1 Year

### 1.8. Measurement Uncertainty

Radiation Uncertainty	:	Ur = 4.1 dB (Horizontal)
		Ur = 4.3 dB (Vertical)
Conduction Uncertainty	:	Uc = 3.4dB

### 1.9. Description of Test Facility

The test facility is recognized, certified, or accredited by the following organizations:

#### FCC-Designation No.: CN5023

Shenzhen Anbotek Compliance Laboratory Limited, EMC Laboratory has been registered and fully described in a report filed with the (FCC) Federal Communications Commission. The acceptance letter from the FCC is maintained in our files. Designation CN5023, July 31, 2017.

#### ISED-Registration No.: 8058A-1

Shenzhen Anbotek Compliance Laboratory Limited, EMC Laboratory has been registered and fully described in a report filed with the (ISED) Innovation, Science and Economic Development Canada. The acceptance letter from the ISED is maintained in our files. Registration 8058A-1, June 13, 2016.

#### Test Location

All Emissions tests were performed at  
Shenzhen Anbotek Compliance Laboratory Limited. at 1/F., Building 1, SEC Industrial Park, No.0409 Qianhai Road, Nanshan District, Shenzhen, Guangdong, China

## 2. Summary of Test Results

Standard	Test Type	Result
15.207 & 15.407	Conducted Emission	PASS
15.205/15.209	Spurious Emission	PASS
15.407(b)	Band Edge	PASS
15.407(a)(5)	Occupy Bandwidth	PASS
15.407(a)(1)(3)	Maximum Conducted Output Power	PASS
15.407(a)(1)(3)	Peak Power Spectral Density	PASS
15.203/15.407g	Antenna Requirement	PASS

### 3. Conducted Emission Test

#### 3.1. Test Standard and Limit

Test Standard	FCC Part15 Section 15.207&15.407		
Test Limit	Frequency	Maximum RF Line Voltage (dBuV)	
		Quasi-peak Level	Average Level
	150kHz~500kHz	66 ~ 56 *	56 ~ 46 *
	500kHz~5MHz	56	46
5MHz~30MHz	60	50	

**Remark:** (1) \*Decreasing linearly with logarithm of the frequency.  
(2) The lower limit shall apply at the transition frequency.

#### 3.2. Test Setup

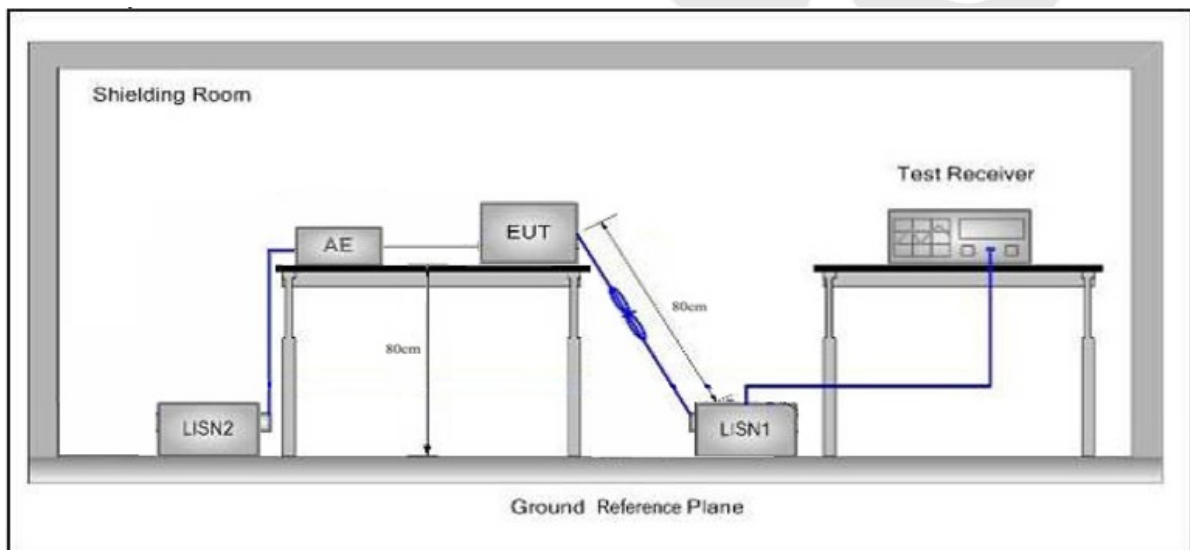

#### 3.3. Test Procedure

The EUT system is connected to the power mains through a line impedance stabilization network (L.I.S.N.). This provides a 50ohm coupling impedance for the EUT system. Please refer the block diagram of the test setup and photographs. Both sides of AC line are checked to find out the maximum conducted emission. In order to find the maximum emission levels, the relative positions of equipment and all of the interface cables shall be changed according to FCC ANSI C63.10-2013 on Conducted Emission Measurement.

The bandwidth of test receiver (ESCI) set at 9kHz.

The frequency range from 150kHz to 30MHz is checked.

#### 3.4. Test Data

Please to see the following pages

**Conducted Emission Test Data**

Test Site: 1# Shielded Room  
 Operating Condition: Keeping TX mode  
 Test Specification: AC 120V, 60Hz for adapter  
 Comment: Live Line  
 Tem.:25°C Hum.:50%

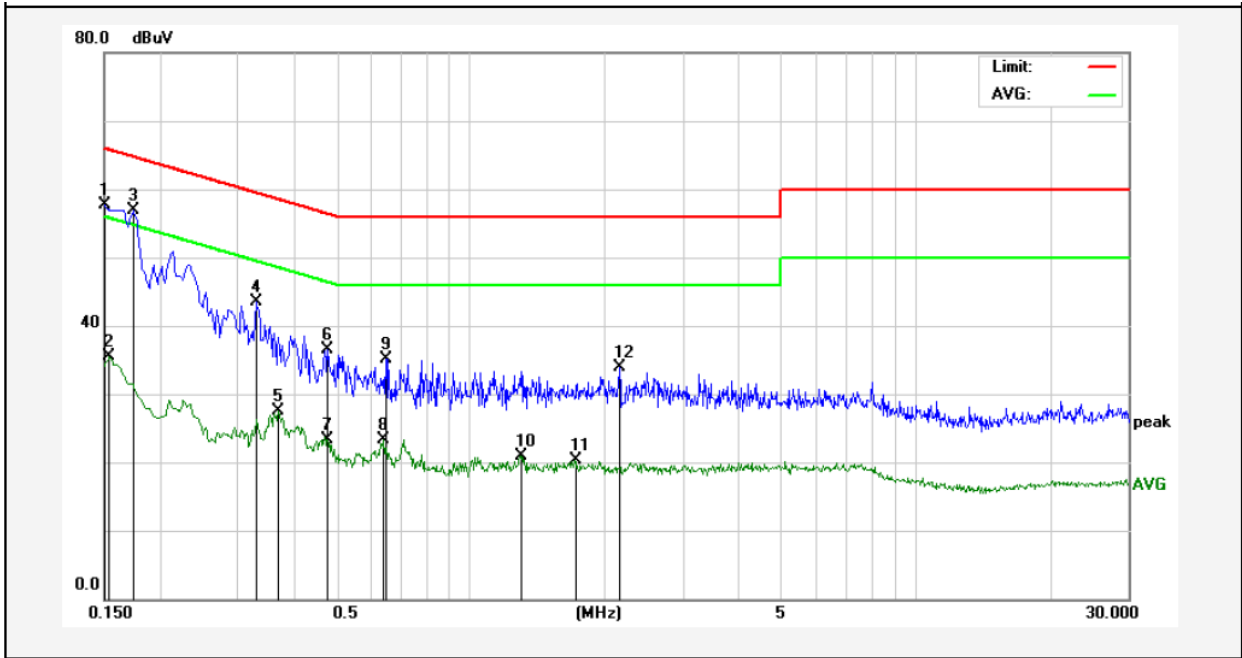

No.	Freq. (MHz)	Reading (dBuV)	Factor (dB)	Result (dBuV)	Limit dBuV	Over Limit (dB)	Detector	Remark
1	0.1499	37.77	19.90	57.67	66.00	-8.33	QP	
2	0.1539	15.57	19.90	35.47	55.78	-20.31	AVG	
3	0.1740	36.94	19.90	56.84	64.76	-7.92	QP	
4	0.3300	23.57	19.90	43.47	59.45	-15.98	QP	
5	0.3700	7.57	19.92	27.49	48.50	-21.01	AVG	
6	0.4780	16.56	19.97	36.53	56.37	-19.84	QP	
7	0.4780	3.24	19.97	23.21	46.37	-23.16	AVG	
8	0.6380	3.30	20.02	23.32	46.00	-22.68	AVG	
9	0.6460	15.15	20.02	35.17	56.00	-20.83	QP	
10	1.3020	0.85	20.13	20.98	46.00	-25.02	AVG	
11	1.7100	0.14	20.13	20.27	46.00	-25.73	AVG	
12	2.1619	13.81	20.14	33.95	56.00	-22.05	QP	

**Conducted Emission Test Data**

Test Site: 1# Shielded Room  
 Operating Condition: Keeping TX mode  
 Test Specification: AC 120V, 60Hz for adapter  
 Comment: Neutral Line  
 Tem.:25°C Hum.:50%

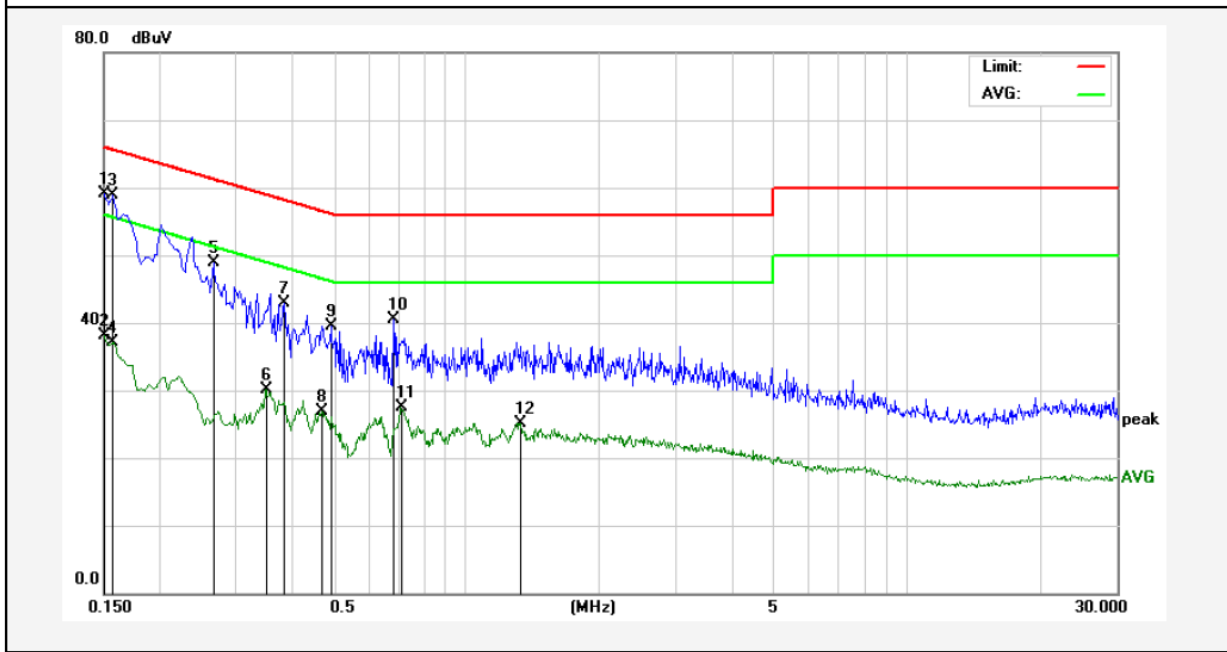

No.	Freq. (MHz)	Reading (dBuV)	Factor (dB)	Result (dBuV)	Limit dBuV	Over Limit (dB)	Detector	Remark
1	0.1499	39.15	19.90	59.05	66.00	-6.95	QP	
2	0.1499	18.15	19.90	38.05	56.00	-17.95	AVG	
3	0.1580	38.96	19.90	58.86	65.56	-6.70	QP	
4	0.1580	17.26	19.90	37.16	55.56	-18.40	AVG	
5	0.2660	28.96	19.89	48.85	61.24	-12.39	QP	
6	0.3500	10.16	19.91	30.07	48.96	-18.89	AVG	
7	0.3860	22.97	19.93	42.90	58.15	-15.25	QP	
8	0.4700	6.85	19.97	26.82	46.51	-19.69	AVG	
9	0.4939	19.43	19.98	39.41	56.10	-16.69	QP	
10	0.6860	20.48	20.04	40.52	56.00	-15.48	QP	
11	0.7100	7.54	20.04	27.58	46.00	-18.42	AVG	
12	1.3260	4.96	20.13	25.09	46.00	-20.91	AVG	

**Conducted Emission Test Data**

Test Site: 1# Shielded Room  
 Operating Condition: Keeping TX mode  
 Test Specification: AC 240V, 60Hz for adapter  
 Comment: Live Line  
 Tem.:25°C Hum.:50%

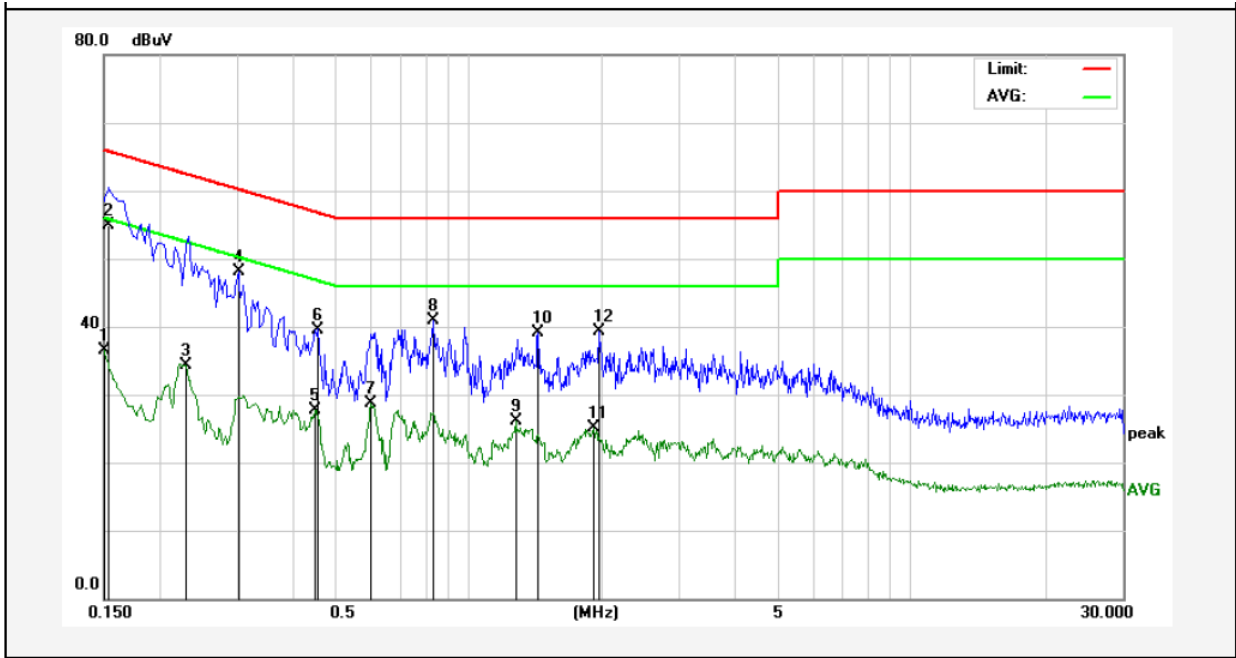

No.	Freq. (MHz)	Reading (dBuV)	Factor (dB)	Result (dBuV)	Limit dBuV	Over Limit (dB)	Detector	Remark
1	0.1500	16.58	19.90	36.48	55.99	-19.51	AVG	
2	0.1539	34.93	19.90	54.83	65.78	-10.95	QP	
3	0.2300	14.50	19.89	34.39	52.45	-18.06	AVG	
4	0.3020	28.21	19.89	48.10	60.19	-12.09	QP	
5	0.4500	7.75	19.96	27.71	46.87	-19.16	AVG	
6	0.4580	19.64	19.96	39.60	56.73	-17.13	QP	
7	0.6020	8.75	20.01	28.76	46.00	-17.24	AVG	
8	0.8340	20.84	20.08	40.92	56.00	-15.08	QP	
9	1.2820	5.89	20.13	26.02	46.00	-19.98	AVG	
10	1.4340	18.91	20.13	39.04	56.00	-16.96	QP	
11	1.9260	5.00	20.14	25.14	46.00	-20.86	AVG	
12	1.9780	19.15	20.14	39.29	56.00	-16.71	QP	

**Conducted Emission Test Data**

Test Site: 1# Shielded Room  
 Operating Condition: Keeping TX mode  
 Test Specification: AC 240V, 60Hz for adapter  
 Comment: Neutral Line  
 Tem.:25°C Hum.:50%

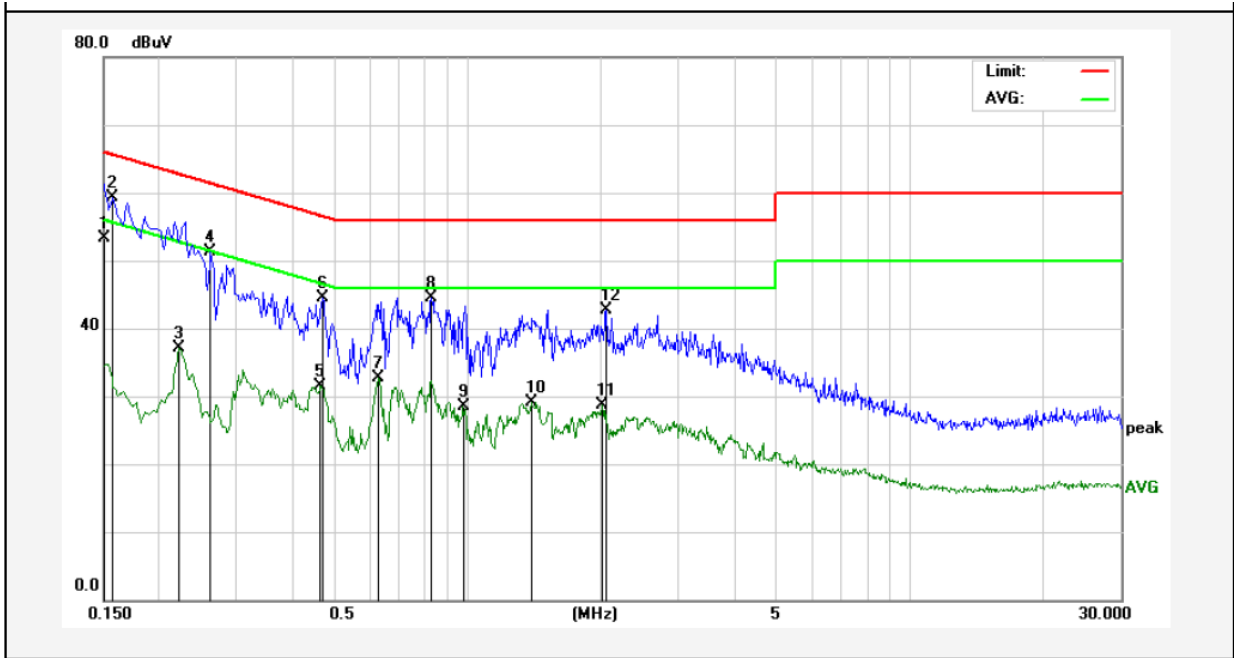

No.	Freq. (MHz)	Reading (dBuV)	Factor (dB)	Result (dBuV)	Limit dBuV	Over Limit (dB)	Detector	Remark
1	0.1499	33.46	19.90	53.36	66.00	-12.64	QP	
2	0.1580	39.37	19.90	59.27	65.56	-6.29	QP	
3	0.2220	17.16	19.89	37.05	52.74	-15.69	AVG	
4	0.2620	31.38	19.89	51.27	61.36	-10.09	QP	
5	0.4660	11.61	19.96	31.57	46.58	-15.01	AVG	
6	0.4700	24.49	19.97	44.46	56.51	-12.05	QP	
7	0.6300	12.74	20.02	32.76	46.00	-13.24	AVG	
8	0.8300	24.47	20.07	44.54	56.00	-11.46	QP	
9	0.9780	8.31	20.11	28.42	46.00	-17.58	AVG	
10	1.3900	9.06	20.13	29.19	46.00	-16.81	AVG	
11	2.0220	8.52	20.14	28.66	46.00	-17.34	AVG	
12	2.0579	22.59	20.14	42.73	56.00	-13.27	QP	



## 4. Radiation Spurious Emission and Band Edge

### 4.1. Test Standard and Limit

Test Standard	FCC Part15 C Section 15.209, 15.205 and 15.407, KDB 789033 D02 General UNII Test Procedures New Rules v01r04
---------------	---

Unwanted spurious emissions fallen in restricted bands per FCC Part15.205 shall comply with the general field strength limits set forth in § 15.209 as below table,

Test Limit	Frequency (MHz)	Field strength (microvolt/meter)	Limit (dBuV/m)	Remark	Measurement distance (m)
	0.009MHz~0.490MHz	2400/F(kHz)	-	-	300
	0.490MHz-1.705MHz	24000/F(kHz)	-	-	30
	1.705MHz-30MHz	30	-	-	30
	30MHz~88MHz	100	40.0	Quasi-peak	3
	88MHz~216MHz	150	43.5	Quasi-peak	3
	216MHz~960MHz	200	46.0	Quasi-peak	3
	960MHz~1000MHz	500	54.0	Quasi-peak	3
	Above 1000MHz	500	54.0	Average	3

**Remark:**

- (1)The lower limit shall apply at the transition frequency.
- (2) 15.35(b), Unless otherwise specified, the limit on peak radio frequency emissions is 20dB above the maximum permitted average emission limit applicable to the equipment under test. This peak limit applies to the total peak emission level radiated by the device.
- (3) Above 1GHz limit:  $E[\text{dB}\mu\text{V}/\text{m}] = \text{EIRP}[\text{dBm}] + 95.2 = 68.2 \text{ dBuV}/\text{m}$ , for  $\text{EIPR}[\text{dBm}] = -27\text{dBm}$ .

For transmitters operating in the 5.725-5.85GHz band:

15.407(b)(4)(i) All emissions shall be limited to a level of -27dBm/MHz at 75MHz or more above or below the band edge increasing linearly to 10dBm/MHz at 25MHz above or below the band edge, and from 25MHz above or below the band edge increasing linearly to a level of 15.6dBm/MHz at 5MHz above or below the band edge, and from 5MHz above or below the band edge increasing linearly to a level of 27dBm/MHz at the band edge.

KDB789033 D02 v01r04 (G)(2)(c)

(i) Sections 15.407(b)(1) to (b)(3) specify the unwanted emission limits for the U-NII-1 and U-NII-2 bands. As specified, emissions above 1000 MHz that are outside of the restricted bands are subject to a peak emission limit of -27dBm/MHz.<sup>3</sup>

(ii) Section 15.407(b)(4) specifies the unwanted emission limit for the U-NII-3 band. A band emissions mask is specified in Section 15.407(b)(4)(i). The emission limits are in terms of a Peak detector. An alternative to the band emissions mask is specified in Section 15.407(b)(4)(ii). The alternative limits are based on the highest antenna gain specified in the filing. There are also marketing and importation restrictions for the devices using the alternative limit.<sup>4</sup>

Note 3: An out-of-band emission that complies with both the average and peak limits of Section 15.209 is not required to satisfy the -27 dBm/MHz peak emission limit.

Note 4: Only devices with antenna gains of 10 dBi or less may be approved using the emission limits specified in Section 15.247(d) till March 2, 2018; all other devices operating in this band must use the mask specified in Section 15.407(b)(4)(i).

#### 4.2. Test Setup

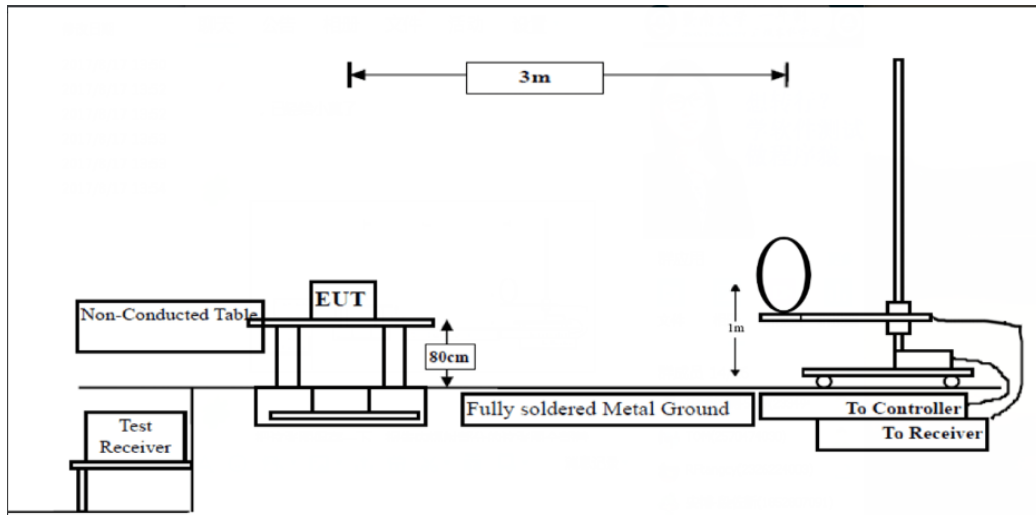

Figure 1. Below 30MHz

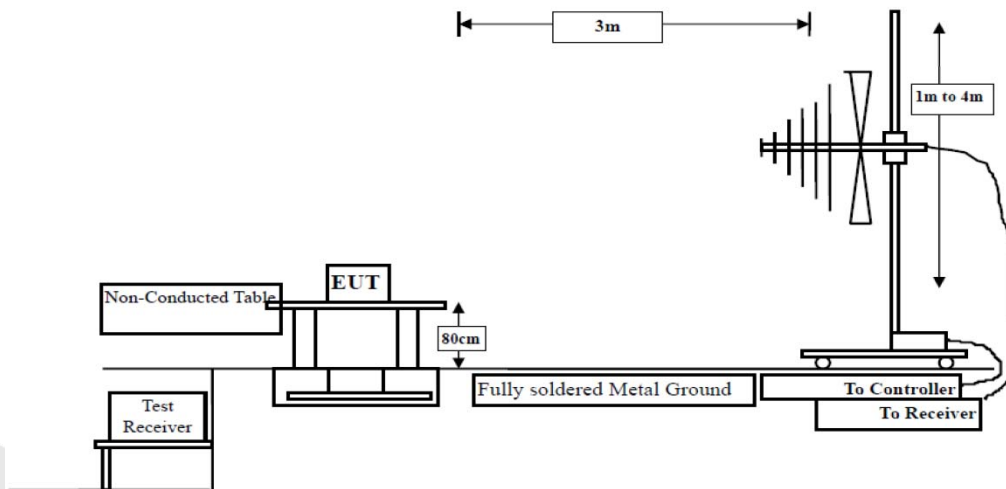

Figure 2. 30MHz to 1GHz

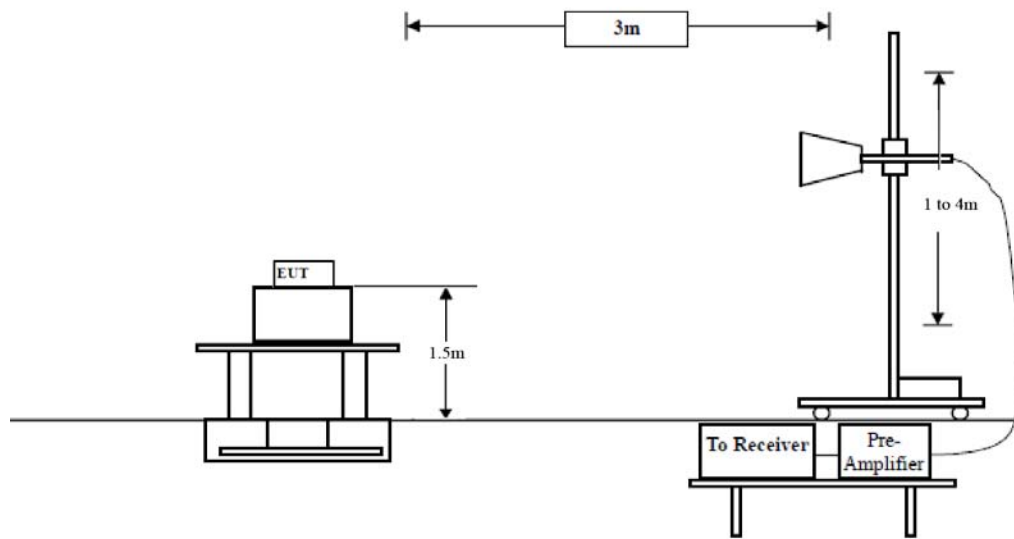

Figure 3. Above 1 GHz

### 4.3. Test Procedure

For below 1GHz: The EUT is placed on a turntable, which is 0.8m above the ground plane.

For above 1GHz: The EUT is placed on a turntable, which is 1.5m above the ground plane.

The turn table can rotate 360 degrees to determine the position of the maximum emission level. The EUT is set 3 meters away from the receiving antenna which is mounted on a antenna tower. The antenna can be moved up and down from 1 to 4 meters to find out the maximum emission level. Rotated the EUT through three orthogonal axes to determine the maximum emissions, both horizontal and vertical polarization of the antenna are set on test. The EUT is tested in 9\*6\*6 Chamber. The device is evaluated in xyz orientation.

For 9kHz to 150kHz, Set the spectrum analyzer as:

RBW = 200Hz, VBW =1kHz, Detector= Quasi-Peak, Trace mode= Max hold, Sweep- auto couple.

For 150kHz to 30MHz, Set the spectrum analyzer as:

RBW = 9KHz, VBW =30kHz, Detector= Quasi-Peak, Trace mode= Max hold, Sweep- auto couple.

For 30MHz to 1000MHz, Set the spectrum analyzer as:

RBW = 100kHz, VBW =300kHz, Detector= Quasi-Peak, Trace mode= Max hold, Sweep- auto couple.

For above 1GHz, Set the spectrum analyzer as:

RBW =1MHz, VBW =1MHz, Detector= Peak, Trace mode= Max hold, Sweep- auto couple.

RBW =1MHz, VBW =10Hz, Detector= Average, Trace mode= Max hold, Sweep- auto couple.

### 4.4. Test Data

#### PASS

The test results of 9kHz-30MHz and above 18000MHz are attenuated more than 20dB below the permissible limits, so the results don't record in the report.

**Test Results (30~1000MHz)**

Job No.: 0217060259W Temp.(°C)/Hum.(%RH): 24.3°C/55%RH  
 Standard: FCC PART 15C Power Source: AC 120V/60Hz  
 Test Mode: TX Mode Polarization: Horizontal

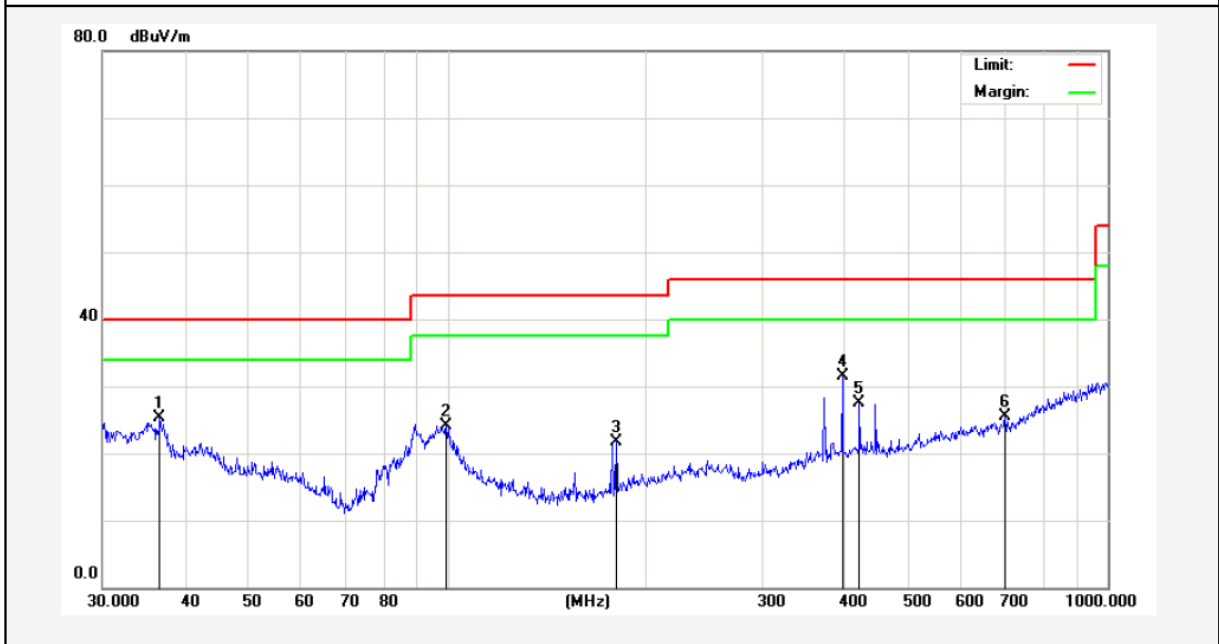

No.	Freq. (MHz)	Reading (dBuV/m)	Factor (dB/m)	Result (dBuV/m)	Limit (dBuV/)	Over Limit (dB)	Detector	Height (cm)	degree (deg)	Remark
1	36.6375	38.23	-13.01	25.22	40.00	-14.78	QP	300	60	
2	99.5281	44.97	-20.79	24.18	43.50	-19.32	QP	300	72	
3	180.0165	43.65	-21.85	21.80	43.50	-21.70	QP	300	89	
4	396.2415	44.38	-12.94	31.44	46.00	-14.56	QP	300	106	
5	420.5803	39.81	-12.38	27.43	46.00	-18.57	QP	300	123	
6	699.3046	34.03	-8.50	25.53	46.00	-20.47	QP	300	149	



**Test Results (30~1000MHz)**

Job No.: 0217060259W Temp.(°C)/Hum.(%RH): 24.3°C/55%RH  
 Standard: FCC PART 15C Power Source: AC 120V/60Hz  
 Test Mode: TX Mode Polarization: Vertical

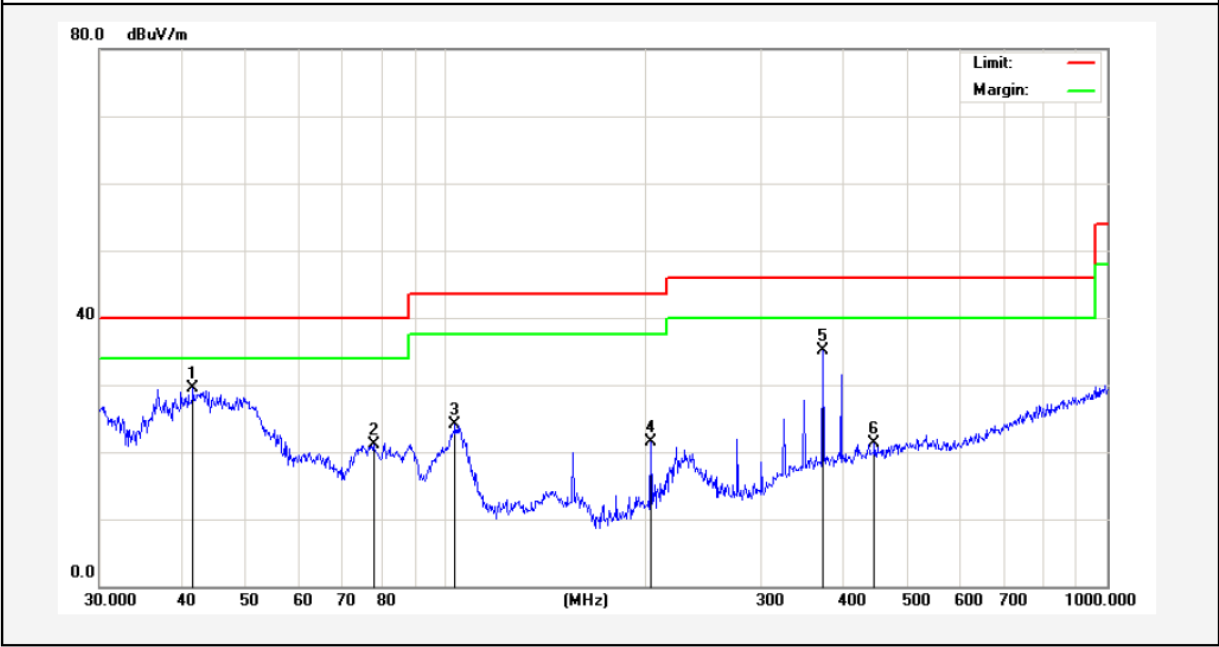

No.	Freq. (MHz)	Reading (dBuV/m)	Factor (dB/m)	Result (dBuV/m)	Limit (dBuV/)	Over Limit (dB)	Detector	Height (cm)	degree (deg)	Remark
1	41.5670	40.50	-10.99	29.51	40.00	-10.49	QP	300	50	
2	77.8654	41.28	-20.24	21.04	40.00	-18.96	QP	300	70	
3	103.4421	39.89	-15.71	24.18	43.50	-19.32	QP	300	82	
4	204.2377	37.22	-15.71	21.51	43.50	-21.99	QP	300	102	
5	372.0045	47.50	-12.43	35.07	46.00	-10.93	QP	300	110	
6	444.8514	32.79	-11.43	21.36	46.00	-24.64	QP	300	145	



**Test Results (Above 1000MHz)**

**ANT 1**

Test mode:	IEEE 802.11a	Test channel:	Low CH
------------	--------------	---------------	--------

Peak value:

Frequency (MHz)	Read Level (dBuV)	Antenna Factor (dB/m)	Cable Loss (dB)	Preamp Factor (dB)	Level (dBuV/m)	Limit Line (dBuV/m)	Over Limit (dB)	Pol.
11490.00	42.32	32.66	18.21	34.01	59.18	74.00	-14.82	V
17235.00	35.02	33.42	20.20	35.00	53.64	68.20	-14.56	V
11490.00	37.65	32.66	18.21	34.01	54.51	74.00	-19.49	H
17235.00	35.78	33.42	20.20	35.00	54.40	68.20	-13.80	H

Average value:

Frequency (MHz)	Read Level (dBuV)	Antenna Factor (dB/m)	Cable Loss (dB)	Preamp Factor (dB)	Level (dBuV/m)	Limit Line (dBuV/m)	Over Limit (dB)	Pol.
11490.00	31.32	32.66	18.21	34.01	48.18	54.00	-5.82	V
17235.00	28.35	33.42	20.20	35.00	46.97	54.00	-7.03	V
11490.00	28.31	32.66	18.21	34.01	45.17	54.00	-8.83	H
17235.00	27.36	33.42	20.20	35.00	45.98	54.00	-8.02	H

Test mode:	IEEE 802.11a	Test channel:	Mid CH
------------	--------------	---------------	--------

Peak value:

Frequency (MHz)	Read Level (dBuV)	Antenna Factor (dB/m)	Cable Loss (dB)	Preamp Factor (dB)	Level (dBuV/m)	Limit Line (dBuV/m)	Over Limit (dB)	Pol.
11570.00	40.06	32.67	18.24	34.02	56.95	74.00	-17.05	V
17355.00	36.45	33.44	20.22	35.01	55.10	68.20	-13.10	V
11570.00	38.53	32.67	18.24	34.02	55.42	74.00	-18.58	H
17355.00	35.96	33.44	20.22	35.01	54.61	68.20	-13.59	H

Average value:

Frequency (MHz)	Read Level (dBuV)	Antenna Factor (dB/m)	Cable Loss (dB)	Preamp Factor (dB)	Level (dBuV/m)	Limit Line (dBuV/m)	Over Limit (dB)	Pol.
11570.00	30.02	32.67	18.24	34.02	46.91	54.00	-7.09	V
17355.00	28.36	33.44	20.22	35.01	47.01	54.00	-6.99	V
11570.00	30.01	32.67	18.24	34.02	46.90	54.00	-7.10	H
17355.00	29.34	33.44	20.22	35.01	47.99	54.00	-6.01	H

Test mode:	IEEE 802.11a	Test channel:	High CH
------------	--------------	---------------	---------

Peak value:

Frequency (MHz)	Read Level (dBuV)	Antenna Factor (dB/m)	Cable Loss (dB)	Preamp Factor (dB)	Level (dBuV/m)	Limit Line (dBuV/m)	Over Limit (dB)	Pol.
11650.00	40.06	32.69	18.26	34.04	56.97	74.00	-17.03	V
17475.00	39.25	33.46	20.23	35.02	57.92	68.20	-10.28	V
11650.00	41.32	32.69	18.26	34.04	58.23	74.00	-15.77	H
17475.00	40.21	33.46	20.23	35.02	58.88	68.20	-9.32	H

Average value:

Frequency (MHz)	Read Level (dBuV)	Antenna Factor (dB/m)	Cable Loss (dB)	Preamp Factor (dB)	Level (dBuV/m)	Limit Line (dBuV/m)	Over Limit (dB)	Pol.
11650.00	30.21	32.69	18.26	34.04	47.12	54.00	-6.88	V
17475.00	30.11	33.46	20.23	35.02	48.78	54.00	-5.22	V
11650.00	29.65	32.69	18.26	34.04	46.56	54.00	-7.44	H
17475.00	29.35	33.46	20.23	35.02	48.02	54.00	-5.98	H

## ANT 2

Test mode:	IEEE 802.11a	Test channel:	Low CH
------------	--------------	---------------	--------

Peak value:

Frequency (MHz)	Read Level (dBuV)	Antenna Factor (dB/m)	Cable Loss (dB)	Preamp Factor (dB)	Level (dBuV/m)	Limit Line (dBuV/m)	Over Limit (dB)	Pol.
11490.00	41.78	32.66	18.21	34.01	58.64	74.00	-15.36	V
17235.00	34.89	33.42	20.20	35.00	53.51	68.20	-14.69	V
11490.00	37.41	32.66	18.21	34.01	54.27	74.00	-19.73	H
17235.00	35.32	33.42	20.20	35.00	53.94	68.20	-14.26	H

Average value:

Frequency (MHz)	Read Level (dBuV)	Antenna Factor (dB/m)	Cable Loss (dB)	Preamp Factor (dB)	Level (dBuV/m)	Limit Line (dBuV/m)	Over Limit (dB)	Pol.
11490.00	30.47	32.66	18.21	34.01	47.33	54.00	-6.67	V
17235.00	28.21	33.42	20.20	35.00	46.83	54.00	-7.17	V
11490.00	28.49	32.66	18.21	34.01	45.35	54.00	-8.65	H
17235.00	26.61	33.42	20.20	35.00	45.23	54.00	-8.77	H

Test mode:	IEEE 802.11a	Test channel:	Mid CH
------------	--------------	---------------	--------

Peak value:

Frequency (MHz)	Read Level (dBuV)	Antenna Factor (dB/m)	Cable Loss (dB)	Preamp Factor (dB)	Level (dBuV/m)	Limit Line (dBuV/m)	Over Limit (dB)	Pol.
11570.00	40.22	32.67	18.24	34.02	57.11	74.00	-16.89	V
17355.00	37.78	33.44	20.22	35.01	56.43	68.20	-11.77	V
11570.00	38.41	32.67	18.24	34.02	55.30	74.00	-18.70	H
17355.00	36.33	33.44	20.22	35.01	54.98	68.20	-13.22	H

Average value:

Frequency (MHz)	Read Level (dBuV)	Antenna Factor (dB/m)	Cable Loss (dB)	Preamp Factor (dB)	Level (dBuV/m)	Limit Line (dBuV/m)	Over Limit (dB)	Pol.
11570.00	31.32	32.67	18.24	34.02	48.21	54.00	-5.79	V
17355.00	27.59	33.44	20.22	35.01	46.24	54.00	-7.76	V
11570.00	31.17	32.67	18.24	34.02	48.06	54.00	-5.94	H
17355.00	29.61	33.44	20.22	35.01	48.26	54.00	-5.74	H

Test mode:	IEEE 802.11a	Test channel:	High CH
------------	--------------	---------------	---------

Peak value:

Frequency (MHz)	Read Level (dBuV)	Antenna Factor (dB/m)	Cable Loss (dB)	Preamp Factor (dB)	Level (dBuV/m)	Limit Line (dBuV/m)	Over Limit (dB)	Pol.
11650.00	40.17	32.69	18.26	34.04	57.08	74.00	-16.92	V
17475.00	39.35	33.46	20.23	35.02	58.02	68.20	-10.18	V
11650.00	41.38	32.69	18.26	34.04	58.29	74.00	-15.71	H
17475.00	40.31	33.46	20.23	35.02	58.98	68.20	-9.22	H

Average value:

Frequency (MHz)	Read Level (dBuV)	Antenna Factor (dB/m)	Cable Loss (dB)	Preamp Factor (dB)	Level (dBuV/m)	Limit Line (dBuV/m)	Over Limit (dB)	Pol.
11650.00	30.33	32.69	18.26	34.04	47.24	54.00	-6.76	V
17475.00	30.42	33.46	20.23	35.02	49.09	54.00	-4.91	V
11650.00	28.71	32.69	18.26	34.04	45.62	54.00	-8.38	H
17475.00	28.41	33.46	20.23	35.02	47.08	54.00	-6.92	H



**ANT 1+ANT 2**

Test mode:	IEEE 802.11n(HT20)	Test channel:	Low CH
------------	--------------------	---------------	--------

Peak value:

Frequency (MHz)	Read Level (dBuV)	Antenna Factor (dB/m)	Cable Loss (dB)	Preamp Factor (dB)	Level (dBuV/m)	Limit Line (dBuV/m)	Over Limit (dB)	Pol.
11490.00	39.81	32.66	18.21	34.01	56.67	74.00	-17.33	V
17235.00	36.21	33.42	20.20	35.00	54.83	68.20	-13.37	V
11490.00	37.15	32.66	18.21	34.01	54.01	74.00	-19.99	H
17235.00	36.25	33.42	20.20	35.00	54.87	68.20	-13.33	H

Average value:

Frequency (MHz)	Read Level (dBuV)	Antenna Factor (dB/m)	Cable Loss (dB)	Preamp Factor (dB)	Level (dBuV/m)	Limit Line (dBuV/m)	Over Limit (dB)	Pol.
11490.00	31.12	32.66	18.21	34.01	47.98	54.00	-6.02	V
17235.00	28.32	33.42	20.20	35.00	46.94	54.00	-7.06	V
11490.00	30.57	32.66	18.21	34.01	47.43	54.00	-6.57	H
17235.00	28.35	33.42	20.20	35.00	46.97	54.00	-7.03	H

Test mode:	IEEE 802.11n(HT20)	Test channel:	Mid CH
------------	--------------------	---------------	--------

Peak value:

Frequency (MHz)	Read Level (dBuV)	Antenna Factor (dB/m)	Cable Loss (dB)	Preamp Factor (dB)	Level (dBuV/m)	Limit Line (dBuV/m)	Over Limit (dB)	Pol.
11570.00	40.35	32.67	18.24	34.02	57.24	74.00	-16.76	V
17355.00	39.12	33.44	20.22	35.01	57.77	68.20	-10.43	V
11570.00	38.35	32.67	18.24	34.02	55.24	74.00	-18.76	H
17355.00	36.12	33.44	20.22	35.01	54.77	68.20	-13.43	H

Average value:

Frequency (MHz)	Read Level (dBuV)	Antenna Factor (dB/m)	Cable Loss (dB)	Preamp Factor (dB)	Level (dBuV/m)	Limit Line (dBuV/m)	Over Limit (dB)	Pol.
11570.00	29.13	32.67	18.24	34.02	46.02	54.00	-7.98	V
17355.00	27.32	33.44	20.22	35.01	45.97	54.00	-8.03	V
11570.00	29.03	32.67	18.24	34.02	45.92	54.00	-8.08	H
17355.00	28.36	33.44	20.22	35.01	47.01	54.00	-6.99	H

Test mode:	IEEE 802.11n(HT20)	Test channel:	High CH
------------	--------------------	---------------	---------

Peak value:

Frequency (MHz)	Read Level (dBuV)	Antenna Factor (dB/m)	Cable Loss (dB)	Preamp Factor (dB)	Level (dBuV/m)	Limit Line (dBuV/m)	Over Limit (dB)	Pol.
11650.00	41.21	32.69	18.26	34.04	58.12	74.00	-15.88	V
17475.00	38.35	33.46	20.23	35.02	57.02	68.20	-11.18	V
11650.00	36.23	32.69	18.26	34.04	53.14	74.00	-20.86	H
17475.00	38.13	33.46	20.23	35.02	56.80	68.20	-11.40	H

Average value:

Frequency (MHz)	Read Level (dBuV)	Antenna Factor (dB/m)	Cable Loss (dB)	Preamp Factor (dB)	Level (dBuV/m)	Limit Line (dBuV/m)	Over Limit (dB)	Pol.
11650.00	31.25	32.69	18.26	34.04	48.16	54.00	-5.84	V
17475.00	31.09	33.46	20.23	35.02	49.76	54.00	-4.24	V
11650.00	29.32	32.69	18.26	34.04	46.23	54.00	-7.77	H
17475.00	28.74	33.46	20.23	35.02	47.41	54.00	-6.59	H

**ANT 1+ANT2**

Test mode:	IEEE 802.11n(ac20)	Test channel:	Low CH
------------	--------------------	---------------	--------

Peak value:

Frequency (MHz)	Read Level (dBuV)	Antenna Factor (dB/m)	Cable Loss (dB)	Preamp Factor (dB)	Level (dBuV/m)	Limit Line (dBuV/m)	Over Limit (dB)	Pol.
11490.00	41.87	32.66	18.21	34.01	58.73	74.00	-15.27	V
17235.00	35.23	33.42	20.20	35.00	53.85	68.20	-14.35	V
11490.00	38.46	32.66	18.21	34.01	55.32	74.00	-18.68	H
17235.00	35.05	33.42	20.20	35.00	53.67	68.20	-14.53	H

Average value:

Frequency (MHz)	Read Level (dBuV)	Antenna Factor (dB/m)	Cable Loss (dB)	Preamp Factor (dB)	Level (dBuV/m)	Limit Line (dBuV/m)	Over Limit (dB)	Pol.
11490.00	32.16	32.66	18.21	34.01	49.02	54.00	-4.98	V
17235.00	29.34	33.42	20.20	35.00	47.96	54.00	-6.04	V
11490.00	30.25	32.66	18.21	34.01	47.11	54.00	-6.89	H
17235.00	27.22	33.42	20.20	35.00	45.84	54.00	-8.16	H

Test mode:	IEEE 802.11n(ac20)	Test channel:	Mid CH
------------	--------------------	---------------	--------

Peak value:

Frequency (MHz)	Read Level (dBuV)	Antenna Factor (dB/m)	Cable Loss (dB)	Preamp Factor (dB)	Level (dBuV/m)	Limit Line (dBuV/m)	Over Limit (dB)	Pol.
11570.00	40.73	32.67	18.24	34.02	57.62	74.00	-16.38	V
17355.00	37.41	33.44	20.22	35.01	56.06	68.20	-12.14	V
11570.00	39.22	32.67	18.24	34.02	56.11	74.00	-17.89	H
17355.00	36.10	33.44	20.22	35.01	54.75	68.20	-13.45	H

Average value:

Frequency (MHz)	Read Level (dBuV)	Antenna Factor (dB/m)	Cable Loss (dB)	Preamp Factor (dB)	Level (dBuV/m)	Limit Line (dBuV/m)	Over Limit (dB)	Pol.
11570.00	30.35	32.67	18.24	34.02	47.24	54.00	-6.76	V
17355.00	27.49	33.44	20.22	35.01	46.14	54.00	-7.86	V
11570.00	29.42	32.67	18.24	34.02	46.31	54.00	-7.69	H
17355.00	27.15	33.44	20.22	35.01	45.80	54.00	-8.20	H

Test mode:	IEEE 802.11n(ac20)	Test channel:	High CH
------------	--------------------	---------------	---------

Peak value:

Frequency (MHz)	Read Level (dBuV)	Antenna Factor (dB/m)	Cable Loss (dB)	Preamp Factor (dB)	Level (dBuV/m)	Limit Line (dBuV/m)	Over Limit (dB)	Pol.
11650.00	40.34	32.69	18.26	34.04	57.25	74.00	-16.75	V
17475.00	38.56	33.46	20.23	35.02	57.23	68.20	-10.97	V
11650.00	39.22	32.69	18.26	34.04	56.13	74.00	-17.87	H
17475.00	37.25	33.46	20.23	35.02	55.92	68.20	-12.28	H

Average value:

Frequency (MHz)	Read Level (dBuV)	Antenna Factor (dB/m)	Cable Loss (dB)	Preamp Factor (dB)	Level (dBuV/m)	Limit Line (dBuV/m)	Over Limit (dB)	Pol.
11650.00	30.17	32.69	18.26	34.04	47.08	54.00	-6.92	V
17475.00	28.14	33.46	20.23	35.02	46.81	54.00	-7.19	V
11650.00	28.85	32.69	18.26	34.04	45.76	54.00	-8.24	H
17475.00	27.42	33.46	20.23	35.02	46.09	54.00	-7.91	H

**ANT1+ANT2**

Test mode:	IEEE 802.11n(HT40)	Test channel:	Low CH
------------	--------------------	---------------	--------

Peak value:

Frequency (MHz)	Read Level (dBuV)	Antenna Factor (dB/m)	Cable Loss (dB)	Preamp Factor (dB)	Level (dBuV/m)	Limit Line (dBuV/m)	Over Limit (dB)	Pol.
11510.00	37.76	32.66	18.21	34.01	54.62	74.00	-19.38	V
17265.00	35.87	33.43	20.21	35.00	54.51	68.20	-13.69	V
11510.00	37.63	32.66	18.21	34.01	54.49	74.00	-19.51	H
17265.00	35.74	33.43	20.21	35.00	54.38	68.20	-13.82	H

Average value:

Frequency (MHz)	Read Level (dBuV)	Antenna Factor (dB/m)	Cable Loss (dB)	Preamp Factor (dB)	Level (dBuV/m)	Limit Line (dBuV/m)	Over Limit (dB)	Pol.
11510.00	30.11	32.66	18.21	34.01	46.97	54.00	-7.03	V
17265.00	28.83	33.43	20.21	35.00	47.47	54.00	-6.53	V
11510.00	30.11	32.66	18.21	34.01	46.97	54.00	-7.03	H
17265.00	27.34	33.43	20.21	35.00	45.98	54.00	-8.02	H

Test mode:	IEEE 802.11n(HT40)	Test channel:	High CH
------------	--------------------	---------------	---------

Peak value:

Frequency (MHz)	Read Level (dBuV)	Antenna Factor (dB/m)	Cable Loss (dB)	Preamp Factor (dB)	Level (dBuV/m)	Limit Line (dBuV/m)	Over Limit (dB)	Pol.
11590.00	42.25	32.68	18.24	34.03	59.14	74.00	-14.86	V
17385.00	39.12	33.45	20.22	35.02	57.77	68.20	-10.43	V
11590.00	37.41	32.68	18.24	34.03	54.30	74.00	-19.70	H
17385.00	38.53	33.45	20.22	35.02	57.18	68.20	-11.02	H

Average value:

Frequency (MHz)	Read Level (dBuV)	Antenna Factor (dB/m)	Cable Loss (dB)	Preamp Factor (dB)	Level (dBuV/m)	Limit Line (dBuV/m)	Over Limit (dB)	Pol.
11590.00	32.13	32.68	18.24	34.03	49.02	54.00	-4.98	V
17385.00	29.49	33.45	20.22	35.02	48.14	54.00	-5.86	V
11590.00	31.47	32.68	18.24	34.03	48.36	54.00	-5.64	H
17385.00	28.41	33.45	20.22	35.02	47.06	54.00	-6.94	H

**ANT1+ANT2**

Test mode:	IEEE 802.11ac(HT40)	Test channel:	Low CH
------------	---------------------	---------------	--------

Peak value:

Frequency (MHz)	Read Level (dBuV)	Antenna Factor (dB/m)	Cable Loss (dB)	Preamp Factor (dB)	Level (dBuV/m)	Limit Line (dBuV/m)	Over Limit (dB)	Pol.
11510.00	37.48	32.66	18.21	34.01	54.34	74.00	-19.66	V
17265.00	35.27	33.43	20.21	35.00	53.91	68.20	-14.29	V
11510.00	37.21	32.66	18.21	34.01	54.07	74.00	-19.93	H
17265.00	35.53	33.43	20.21	35.00	54.17	68.20	-14.03	H

Average value:

Frequency (MHz)	Read Level (dBuV)	Antenna Factor (dB/m)	Cable Loss (dB)	Preamp Factor (dB)	Level (dBuV/m)	Limit Line (dBuV/m)	Over Limit (dB)	Pol.
11510.00	31.24	32.66	18.21	34.01	48.10	54.00	-5.90	V
17265.00	28.35	33.43	20.21	35.00	46.99	54.00	-7.01	V
11510.00	30.34	32.66	18.21	34.01	47.20	54.00	-6.80	H
17265.00	27.69	33.43	20.21	35.00	46.33	54.00	-7.67	H

Test mode:	IEEE 802.11ac(HT40)	Test channel:	High CH
------------	---------------------	---------------	---------

Peak value:

Frequency (MHz)	Read Level (dBuV)	Antenna Factor (dB/m)	Cable Loss (dB)	Preamp Factor (dB)	Level (dBuV/m)	Limit Line (dBuV/m)	Over Limit (dB)	Pol.
11590.00	41.78	32.68	18.24	34.03	58.67	74.00	-15.33	V
17385.00	38.47	33.45	20.22	35.02	57.12	68.20	-11.08	V
11590.00	39.27	32.68	18.24	34.03	56.16	74.00	-17.84	H
17385.00	37.42	33.45	20.22	35.02	56.07	68.20	-12.13	H

Average value:

Frequency (MHz)	Read Level (dBuV)	Antenna Factor (dB/m)	Cable Loss (dB)	Preamp Factor (dB)	Level (dBuV/m)	Limit Line (dBuV/m)	Over Limit (dB)	Pol.
11590.00	31.78	32.68	18.24	34.03	48.67	54.00	-5.33	V
17385.00	28.89	33.45	20.22	35.02	47.54	54.00	-6.46	V
11590.00	30.27	32.68	18.24	34.03	47.16	54.00	-6.84	H
17385.00	28.35	33.45	20.22	35.02	47.00	54.00	-7.00	H

**ANT1+ANT2**

Test mode:	IEEE 802.11ac(HT80)	Test channel:	
------------	---------------------	---------------	--

Peak value:

Frequency (MHz)	Read Level (dBuV)	Antenna Factor (dB/m)	Cable Loss (dB)	Preamp Factor (dB)	Level (dBuV/m)	Limit Line (dBuV/m)	Over Limit (dB)	Pol.
11550.00	41.29	32.67	18.24	34.02	58.18	74.00	-15.82	V
17325.00	36.49	33.44	20.22	35.01	55.14	68.20	-13.06	V
11550.00	38.73	32.67	18.24	34.02	55.62	74.00	-18.38	H
17325.00	35.47	33.44	20.22	35.01	54.12	68.20	-14.08	H

Average value:

Frequency (MHz)	Read Level (dBuV)	Antenna Factor (dB/m)	Cable Loss (dB)	Preamp Factor (dB)	Level (dBuV/m)	Limit Line (dBuV/m)	Over Limit (dB)	Pol.
11550.00	30.19	32.67	18.24	34.02	47.08	54.00	-6.92	V
17325.00	28.25	33.44	20.22	35.01	46.90	54.00	-7.10	V
11550.00	30.04	32.67	18.24	34.02	46.93	54.00	-7.07	H
17325.00	27.93	33.44	20.22	35.01	46.58	54.00	-7.42	H

Note:

1. Final Level = Receiver Read level + Antenna Factor + Cable Loss - Preamplifier Factor

**Radiated Band Edge:**

**ANT 1**

Test Mode: 802.11a								
Peak Value								
Frequency (MHz)	Read Level (dBuV)	Antenna Factor (dB/m)	Cable Loss (dB)	Preamp Factor (dB)	Level (dBuV/m)	Limit (dBuV/m)	Over Limit (dB)	Pol.
5725.00	41.33	29.78	15.69	31.08	55.72	68.20	-12.48	H
5850.00	40.65	30.01	16.82	32.09	55.39	68.20	-12.81	H
5725.00	42.14	29.78	15.69	31.08	56.53	68.20	-11.67	V
5850.00	43.40	30.01	16.82	32.09	58.14	68.20	-10.06	V
Average Value								
Frequency (MHz)	Read Level (dBuV)	Antenna Factor (dB/m)	Cable Loss (dB)	Preamp Factor (dB)	Level (dBuV/m)	Limit (dBuV/m)	Over Limit (dB)	Pol.
5725.00	34.80	29.78	15.69	31.08	49.19	54.00	-4.81	H
5850.00	34.57	30.01	16.82	32.09	49.31	54.00	-4.69	H
5725.00	35.22	29.78	15.69	31.08	49.61	54.00	-4.39	V
5850.00	35.21	30.01	16.82	32.09	49.95	54.00	-4.05	V

**ANT 2**

Test Mode: 802.11a								
Peak Value								
Frequency (MHz)	Read Level (dBuV)	Antenna Factor (dB/m)	Cable Loss (dB)	Preamp Factor (dB)	Level (dBuV/m)	Limit (dBuV/m)	Over Limit (dB)	Pol.
5725.00	41.78	29.78	15.69	31.08	56.17	68.20	-12.03	H
5850.00	41.07	30.01	16.82	32.09	55.81	68.20	-12.39	H
5725.00	42.36	29.78	15.69	31.08	56.75	68.20	-11.45	V
5850.00	43.75	30.01	16.82	32.09	58.49	68.20	-9.71	V
Average Value								
Frequency (MHz)	Read Level (dBuV)	Antenna Factor (dB/m)	Cable Loss (dB)	Preamp Factor (dB)	Level (dBuV/m)	Limit (dBuV/m)	Over Limit (dB)	Pol.
5725.00	35.35	29.78	15.69	31.08	49.74	54.00	-4.26	H
5850.00	34.76	30.01	16.82	32.09	49.50	54.00	-4.50	H
5725.00	34.88	29.78	15.69	31.08	49.27	54.00	-4.73	V
5850.00	35.13	30.01	16.82	32.09	49.87	54.00	-4.13	V

**ANT 1+ANT 2**

Test Mode: 802.11n20								
Peak Value								
Frequency (MHz)	Read Level (dBuV)	Antenna Factor (dB/m)	Cable Loss (dB)	Preamp Factor (dB)	Level (dBuV/m)	Limit (dBuV/m)	Over Limit (dB)	Pol.
5725.00	40.85	29.78	15.69	31.08	55.24	68.20	-12.96	H
5850.00	41.69	30.01	16.82	32.09	56.43	68.20	-11.77	H
5725.00	42.01	29.78	15.69	31.08	56.40	68.20	-11.80	V
5850.00	43.00	30.01	16.82	32.09	57.74	68.20	-10.46	V
Average Value								
Frequency (MHz)	Read Level (dBuV)	Antenna Factor (dB/m)	Cable Loss (dB)	Preamp Factor (dB)	Level (dBuV/m)	Limit (dBuV/m)	Over Limit (dB)	Pol.
5725.00	33.96	29.78	15.69	31.08	48.35	54.00	-5.65	H
5850.00	34.87	30.01	16.82	32.09	49.61	54.00	-4.39	H
5725.00	34.96	29.78	15.69	31.08	49.35	54.00	-4.65	V
5850.00	35.22	30.01	16.82	32.09	49.96	54.00	-4.04	V

**ANT 1+ANT 2**

Test Mode: 802.11ac20								
Peak Value								
Frequency (MHz)	Read Level (dBuV)	Antenna Factor (dB/m)	Cable Loss (dB)	Preamp Factor (dB)	Level (dBuV/m)	Limit (dBuV/m)	Over Limit (dB)	Pol.
5725.00	40.96	29.78	15.69	31.08	55.35	68.20	-12.85	H
5850.00	41.63	30.01	16.82	32.09	56.37	68.20	-11.83	H
5725.00	42.99	29.78	15.69	31.08	57.38	68.20	-10.82	V
5850.00	42.10	30.01	16.82	32.09	56.84	68.20	-11.36	V
Average Value								
Frequency (MHz)	Read Level (dBuV)	Antenna Factor (dB/m)	Cable Loss (dB)	Preamp Factor (dB)	Level (dBuV/m)	Limit (dBuV/m)	Over Limit (dB)	Pol.
5725.00	33.99	29.78	15.69	31.08	48.38	54.00	-5.62	H
5850.00	33.84	30.01	16.82	32.09	48.58	54.00	-5.42	H
5725.00	33.62	29.78	15.69	31.08	48.01	54.00	-5.99	V
5850.00	34.50	30.01	16.82	32.09	49.24	54.00	-4.76	V

**ANT 2**



Test Mode: 802.11ac20								
Peak Value								
Frequency (MHz)	Read Level (dBuV)	Antenna Factor (dB/m)	Cable Loss (dB)	Preamp Factor (dB)	Level (dBuV/m)	Limit (dBuV/m)	Over Limit (dB)	Pol.
5725.00	41.45	29.78	15.69	31.08	55.84	68.20	-12.36	H
5850.00	40.33	30.01	16.82	32.09	55.07	68.20	-13.13	H
5725.00	41.23	29.78	15.69	31.08	55.62	68.20	-12.58	V
5850.00	42.17	30.01	16.82	32.09	56.91	68.20	-11.29	V
Average Value								
Frequency (MHz)	Read Level (dBuV)	Antenna Factor (dB/m)	Cable Loss (dB)	Preamp Factor (dB)	Level (dBuV/m)	Limit (dBuV/m)	Over Limit (dB)	Pol.
5725.00	32.42	29.78	15.69	31.08	46.81	54.00	-7.19	H
5850.00	33.38	30.01	16.82	32.09	48.12	54.00	-5.88	H
5725.00	33.78	29.78	15.69	31.08	48.17	54.00	-5.83	V
5850.00	34.49	30.01	16.82	32.09	49.23	54.00	-4.77	V

**ANT 1+ANT 2**

Test Mode: 802.11n40								
Peak Value								
Frequency (MHz)	Read Level (dBuV)	Antenna Factor (dB/m)	Cable Loss (dB)	Preamp Factor (dB)	Level (dBuV/m)	Limit (dBuV/m)	Over Limit (dB)	Pol.
5725.00	40.96	29.78	15.69	31.08	55.35	68.20	-12.85	H
5850.00	41.65	30.01	16.82	32.09	56.39	68.20	-11.81	H
5725.00	41.01	29.78	15.69	31.08	55.40	68.20	-12.80	V
5850.00	42.57	30.01	16.82	32.09	57.31	68.20	-10.89	V
Average Value								
Frequency (MHz)	Read Level (dBuV)	Antenna Factor (dB/m)	Cable Loss (dB)	Preamp Factor (dB)	Level (dBuV/m)	Limit (dBuV/m)	Over Limit (dB)	Pol.
5725.00	33.96	29.78	15.69	31.08	48.35	54.00	-5.65	H
5850.00	33.94	30.01	16.82	32.09	48.68	54.00	-5.32	H
5725.00	32.98	29.78	15.69	31.08	47.37	54.00	-6.63	V
5850.00	34.57	30.01	16.82	32.09	49.31	54.00	-4.69	V

**ANT 1+ANT 2**

Test Mode: 802.11ac40								
Peak Value								
Frequency (MHz)	Read Level (dBuV)	Antenna Factor (dB/m)	Cable Loss (dB)	Preamp Factor (dB)	Level (dBuV/m)	Limit (dBuV/m)	Over Limit (dB)	Pol.
5725.00	40.25	29.78	15.69	31.08	54.64	68.20	-13.56	H
5850.00	41.00	30.01	16.82	32.09	55.74	68.20	-12.46	H
5725.00	40.29	29.78	15.69	31.08	54.68	68.20	-13.52	V
5850.00	42.65	30.01	16.82	32.09	57.39	68.20	-10.81	V
Average Value								
Frequency (MHz)	Read Level (dBuV)	Antenna Factor (dB/m)	Cable Loss (dB)	Preamp Factor (dB)	Level (dBuV/m)	Limit (dBuV/m)	Over Limit (dB)	Pol.
5725.00	34.87	29.78	15.69	31.08	49.26	54.00	-4.74	H
5850.00	33.96	30.01	16.82	32.09	48.70	54.00	-5.30	H
5725.00	32.65	29.78	15.69	31.08	47.04	54.00	-6.96	V
5850.00	34.98	30.01	16.82	32.09	49.72	54.00	-4.28	V

**ANT 1+ANT 2**

Test Mode: 802.11ac80								
Peak Value								
Frequency (MHz)	Read Level (dBuV)	Antenna Factor (dB/m)	Cable Loss (dB)	Preamp Factor (dB)	Level (dBuV/m)	Limit (dBuV/m)	Over Limit (dB)	Pol.
5725.00	42.01	29.78	15.69	31.08	56.40	68.20	-11.80	H
5850.00	41.96	30.01	16.82	32.09	56.70	68.20	-11.50	H
5725.00	40.63	29.78	15.69	31.08	55.02	68.20	-13.18	V
5850.00	42.11	30.01	16.82	32.09	56.85	68.20	-11.35	V
Average Value								
Frequency (MHz)	Read Level (dBuV)	Antenna Factor (dB/m)	Cable Loss (dB)	Preamp Factor (dB)	Level (dBuV/m)	Limit (dBuV/m)	Over Limit (dB)	Pol.
5725.00	32.96	29.78	15.69	31.08	47.35	54.00	-6.65	H
5850.00	33.69	30.01	16.82	32.09	48.43	54.00	-5.57	H
5725.00	32.47	29.78	15.69	31.08	46.86	54.00	-7.14	V
5850.00	34.98	30.01	16.82	32.09	49.72	54.00	-4.28	V

For conducted test:  
ANT 1

802.11a: Band Edge, Left Side

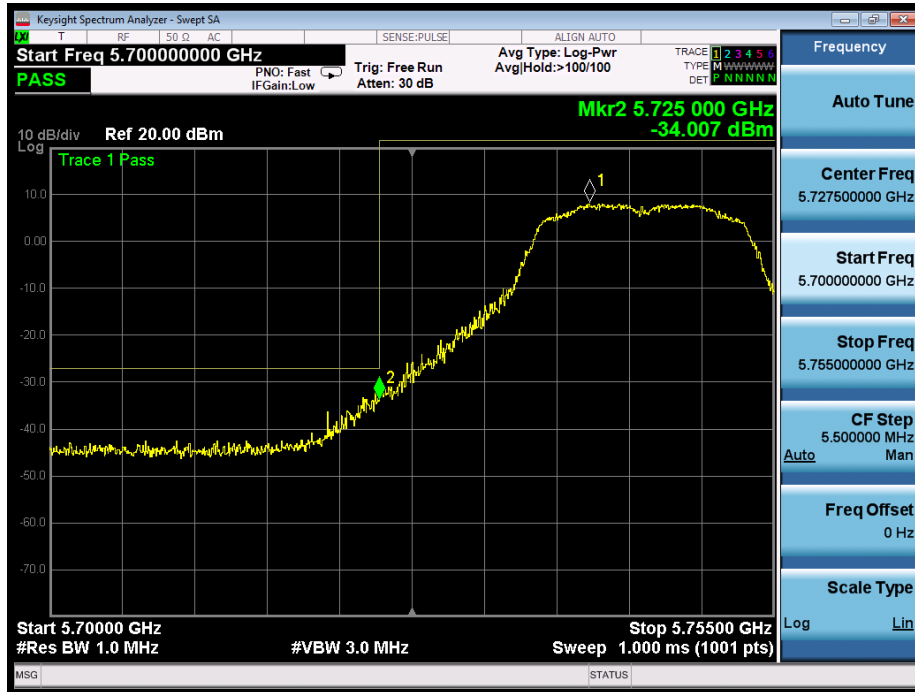

802.11a: Band Edge, Right Side



802.11n(20): Band Edge, Left Side

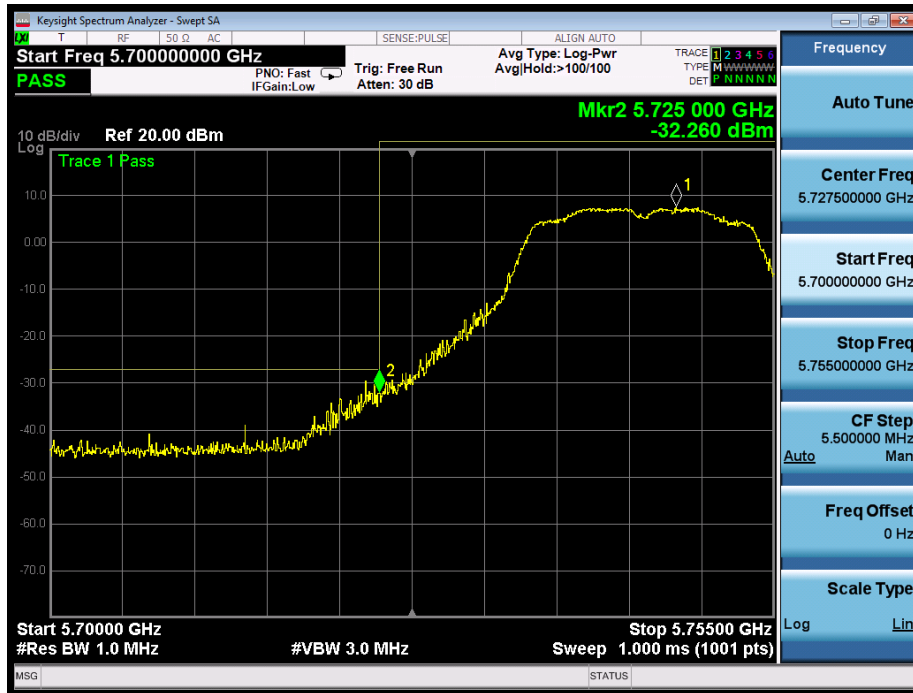

802.11n(20): Band Edge, Right Side



802.11ac(20): Band Edge, Left Side

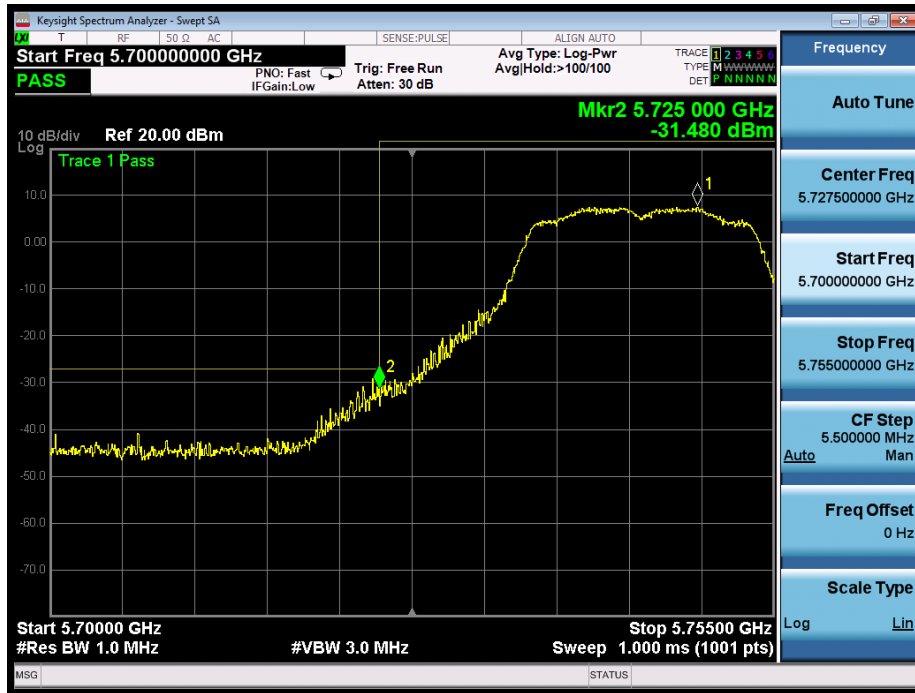

802.11ac(20): Band Edge, Right Side

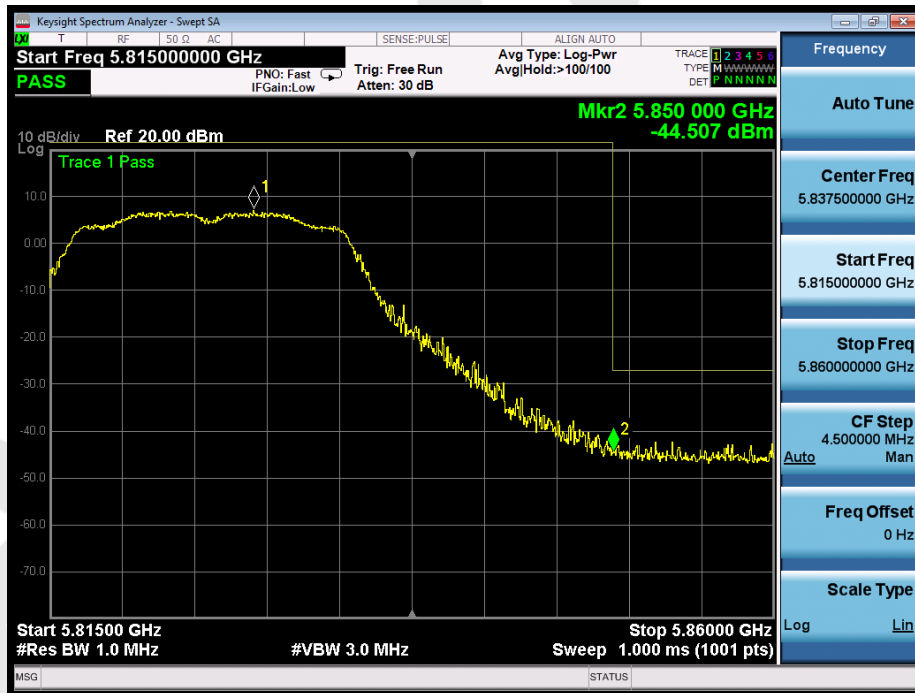

802.11n(40): Band Edge, Left Side



802.11n(40): Band Edge, Right Side



802.11ac(40): Band Edge, Left Side



802.11ac(40): Band Edge, Right Side



802.11ac(80): Band Edge, Left Side

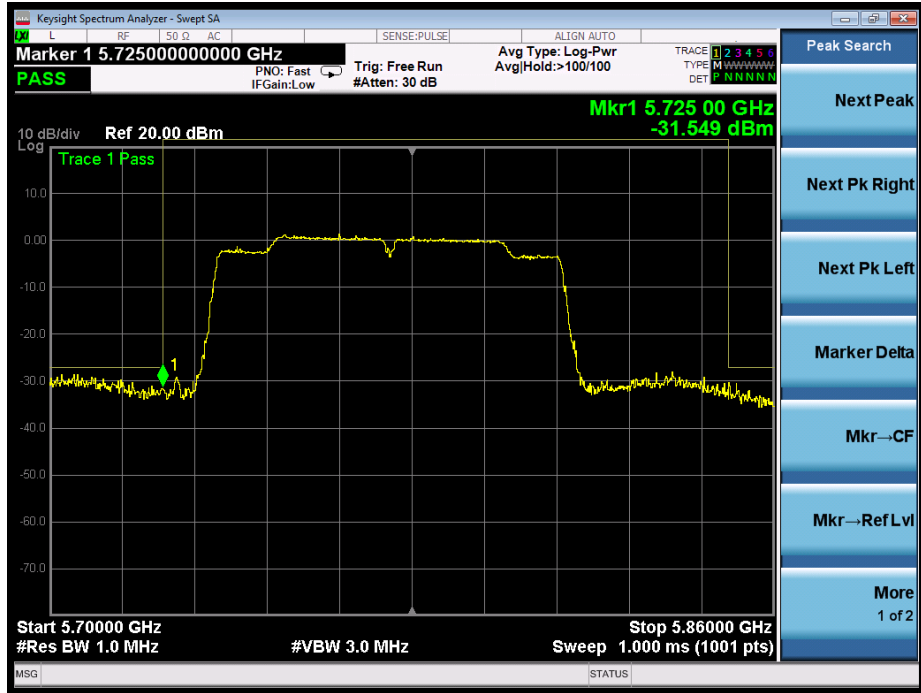

802.11ac(80): Band Edge, Right Side





ANT 2

802.11a: Band Edge, Left Side

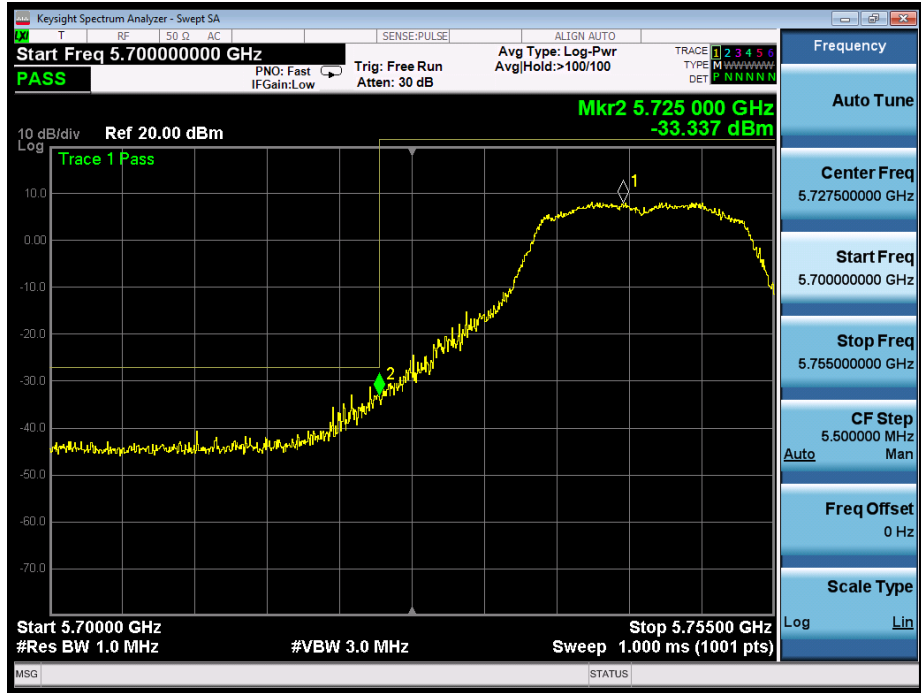

802.11a: Band Edge, Right Side



802.11n(20): Band Edge, Left Side

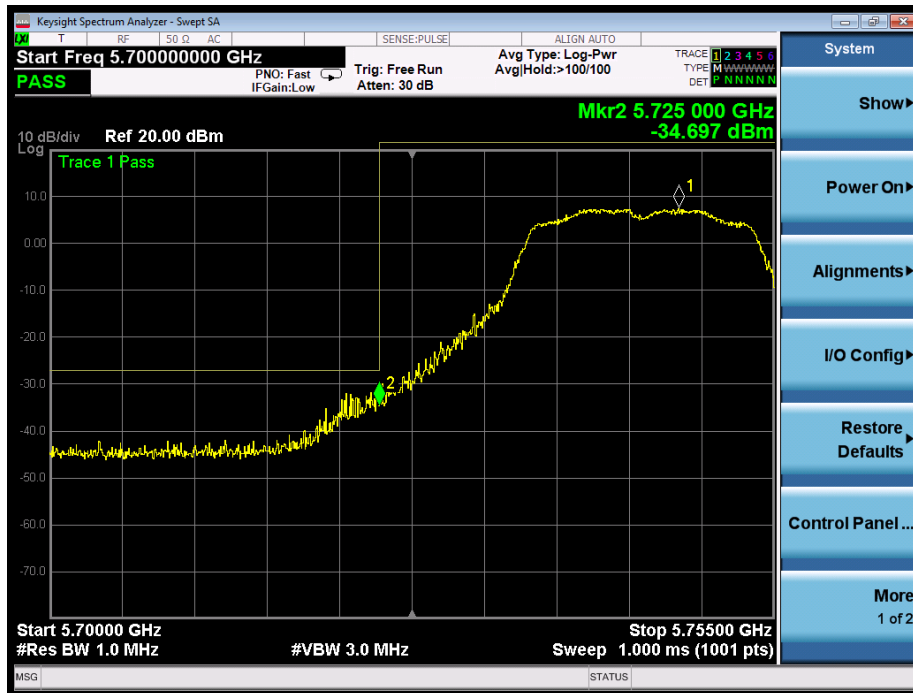

802.11n(20): Band Edge, Right Side

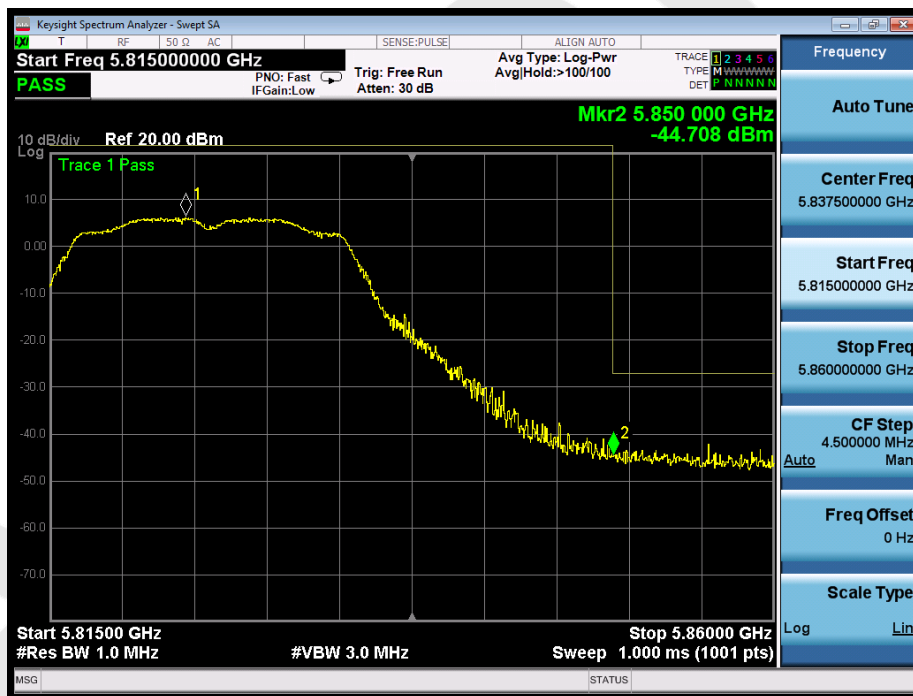

802.11ac(20): Band Edge, Left Side

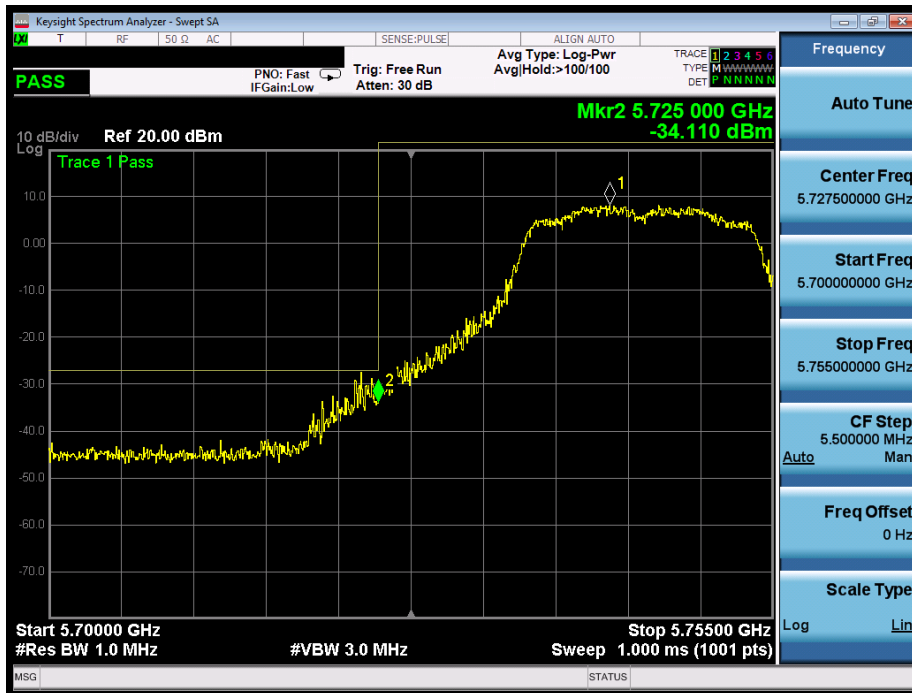

802.11ac(20): Band Edge, Right Side

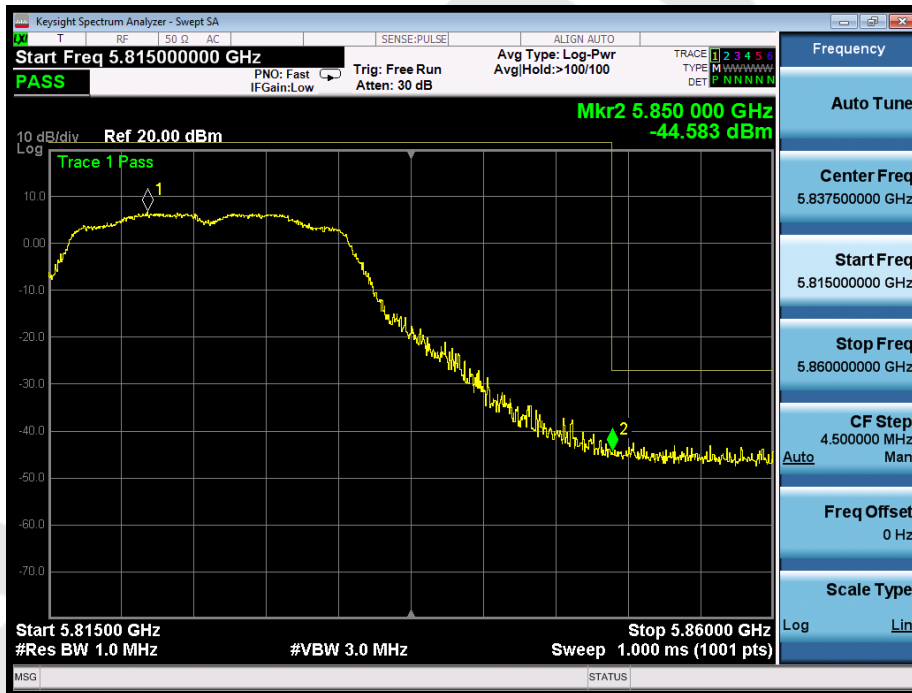

802.11n(40): Band Edge, Left Side

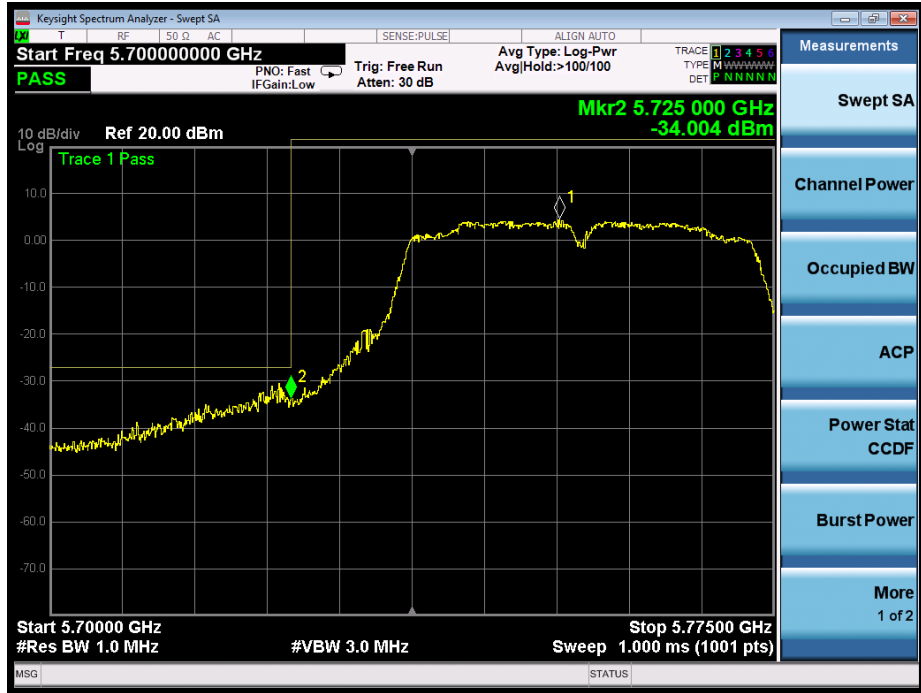

802.11n(40): Band Edge, Right Side



802.11ac(40): Band Edge, Left Side

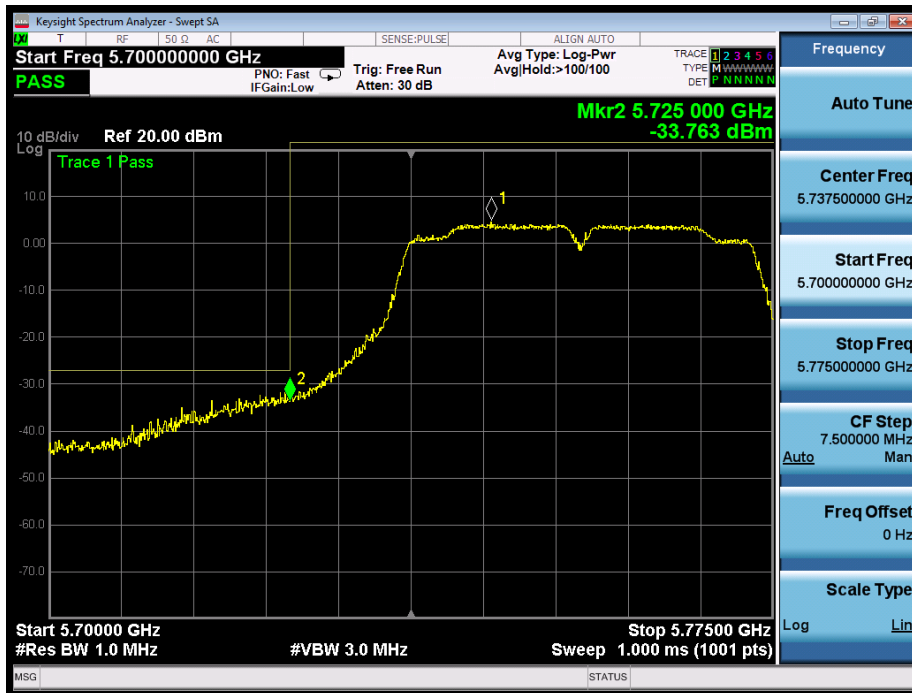

802.11ac(40): Band Edge, Right Side



802.11ac(80): Band Edge, Left Side



802.11ac(80): Band Edge, Right Side



## 5. Maximum Peak Output Power Test

### 5.1. Test Standard and Limit

Test Standard	FCC Part15 C Section 15.407 (a)(1) (3)
Test Limit	30dBm (1W)

### 5.2. Test Setup

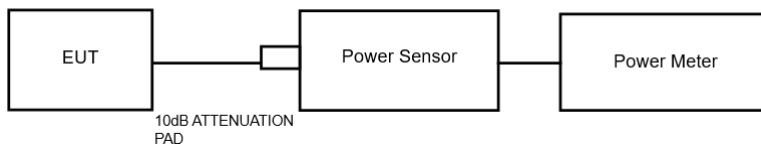

### 5.3. Test Procedure

1. The Transmitter output (antenna port) was connected to the power meter.
2. Turn on the EUT and power meter and then record the power value.
3. Repeat above procedures on all channels needed to be tested.

Note: The cable loss and attenuator loss were offset into measure device as an amplitude offset.

### 5.4. Test Data

Test Item	: Max. peak output power	Test Mode	: CH Low ~ CH High
Test Voltage	: AC 120V/60Hz	Temperature	: 24°C
Test Result	: PASS	Humidity	: 55%RH

Mode	Channel Frequency (MHz)	Peak Power output (dBm)			Correctional Limit (dBm)	Results
		ANT1	ANT2	SUM		
802.11a	5745	<b>19.03</b>	18.77		29.00	PASS
	5785	18.38	17.96		29.00	PASS
	5825	17.00	16.81		29.00	PASS
802.11n20	5745	18.07	18.03	21.06	25.90	PASS
	5785	17.33	17.74	20.55	25.90	PASS
	5825	16.74	16.69	19.73	25.90	PASS
802.11ac20	5745	18.45	18.34	<b>21.41</b>	25.90	PASS
	5785	17.53	17.07	20.32	25.90	PASS
	5825	16.67	16.44	19.57	25.90	PASS
802.11n40	5755	17.90	18.34	21.14	25.90	PASS
	5795	17.24	16.84	20.05	25.90	PASS
802.11ac40	5755	17.63	17.02	20.35	25.90	PASS
	5795	17.97	17.26	20.64	25.90	PASS
802.11ac80	5775	18.02	17.58	20.82	25.90	PASS

**Note:**

1) For power test the duty cycle is 100% in continuous transmitting mode. Please see the plot of next page.

2) For 802.11a/n20/ac20 mode,

Power limit Reduction=7-6=1dBi

Correctional limit=30-1=29dBm

For 802.11n20/n40 mode,

Directional gain=GANT +10log(N)dBi =7+10log2=10.1dBi

Power limit Reduction=10.1-6=4.1dBi

Correctional limit=30-4.1=25.9dBm



## 6. Occupy Bandwidth Test

### 6.1. Test Standard

Test Standard	FCC Part15 C Section 15.403(i), 15.407 (e)
---------------	--

### 6.2. Test Setup

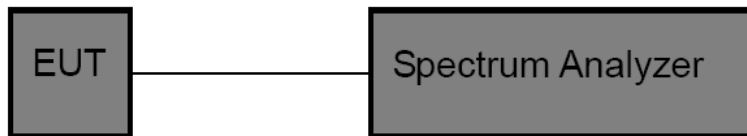

### 6.3. Test Procedure

1. Place the EUT on the table and set it in the transmitting mode.
2. Remove the antenna from the EUT and then connect a low loss RF cable from the antenna port to the spectrum analyzer.

3. Set the spectrum analyzer as:

#### 26 dB & 99% bandwidth

- RBW = approximately 1% of the emission bandwidth;
- Set the VBW > RBW;
- Detector = Peak
- Trace mode = Max hold.
- Sweep - auto couple.

#### 6 dB bandwidth

- RBW = 100kHz;
- Set the video bandwidth (VBW)  $\geq 3$  RBW;
- Detector = Peak
- Trace mode = Max hold.
- Sweep - auto couple.

4. Measure the maximum width of the emission that is 26dB /6dB down from the maximum of the emission. Compare this with the RBW setting of the analyzer.
5. Repeat until all the rest channels are investigated.

### 6.4. Test Data

**ANT 1**

Test Item : 6dB &26dB BW  
Test Voltage : AC 120V/60Hz  
Test Result : PASS

Test Mode : CH Low ~ CH High  
Temperature : 24°C  
Humidity : 55%RH

Mode	Channel Frequency (MHz)	6dB BW(MHz)	Limit	Results
802.11a	5745	15.14	>0.5MHz	PASS
	5785	15.05		PASS
	5825	15.17		PASS
802.11n20	5745	15.17		PASS
	5785	15.15		PASS
	5825	15.11		PASS
802.11ac20	5745	15.15		PASS
	5785	15.11		PASS
	5825	15.14		PASS
802.11n40	5755	35.20		PASS
	5795	35.19		PASS
802.11ac40	5755	35.20		PASS
	5795	35.20		PASS
802.11ac80	5775	75.31	PASS	

Mode	Channel Frequency (MHz)	26dB BW(MHz)	99% Bandwidth (MHz)
802.11a	5745	25.67	16.889
	5785	24.02	16.655
	5825	23.83	16.604
802.11n20	5745	24.82	17.884
	5785	24.87	17.829
	5825	23.16	17.694
802.11ac20	5745	25.51	17.849
	5785	25.26	17.816
	5825	25.23	17.826
802.11n40	5755	45.75	36.203
	5795	43.23	36.160
802.11ac40	5755	46.72	36.199
	5795	43.86	36.172
802.11ac80	5775	81.47	75.499

**ANT 2**

Test Item	: 6dB & 26dB BW	Test Mode	: CH Low ~ CH High
Test Voltage	: AC 120V/60Hz	Temperature	: 24°C
Test Result	: PASS	Humidity	: 55%RH

Mode	Channel Frequency (MHz)	6dB BW(MHz)	Limit	Results
802.11a	5745	15.16	>0.5MHz	PASS
	5785	13.18		PASS
	5825	13.85		PASS
802.11n20	5745	14.20		PASS
	5785	15.17		PASS
	5825	15.02		PASS
802.11ac20	5745	15.08		PASS
	5785	15.13		PASS
	5825	15.12		PASS
802.11n40	5755	35.14		PASS
	5795	35.18		PASS
802.11ac40	5755	35.19		PASS
	5795	29.19	PASS	
802.11ac80	5775	75.34	PASS	

Mode	Channel Frequency (MHz)	26dB BW(MHz)	99% Bandwidth (MHz)
802.11a	5745	25.66	16.869
	5785	24.00	16.156
	5825	23.03	16.640
802.11n20	5745	24.84	17.844
	5785	24.47	17.849
	5825	23.14	17.696
802.11ac20	5745	25.53	17.449
	5785	25.36	16.866
	5825	25.33	17.812
802.11n40	5755	45.54	36.263
	5795	43.43	36.061
802.11ac40	5755	46.32	36.191
	5795	43.36	36.171
802.11ac80	5775	81.57	75.999

### 6dB Bandwidth

ANT 1

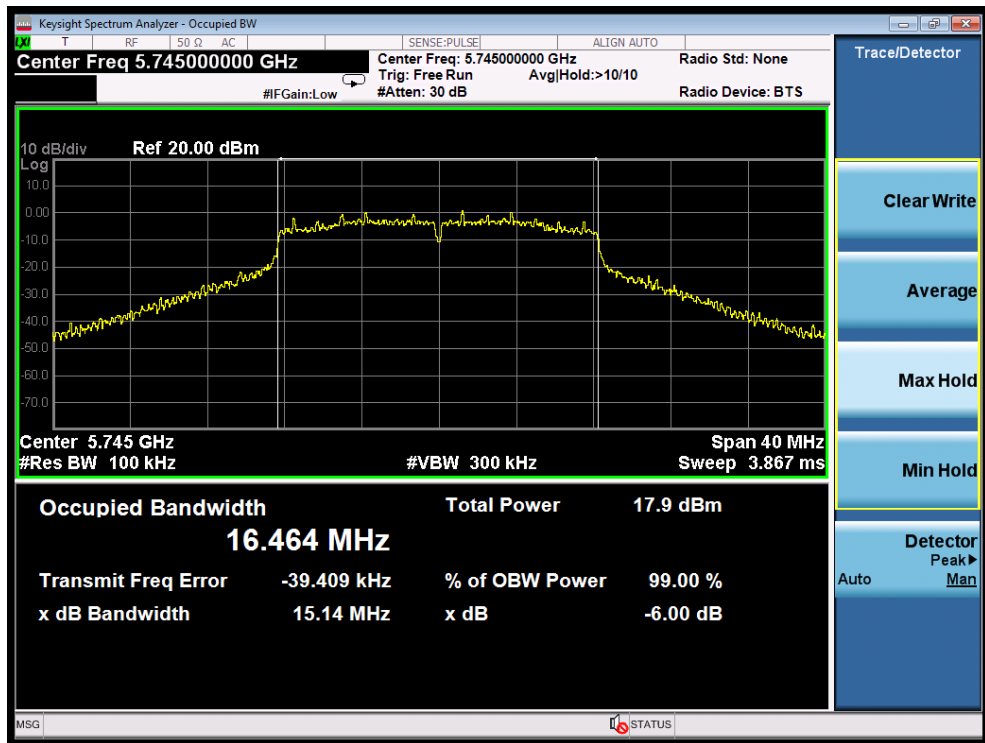

Test Mode: 802.11a--Low

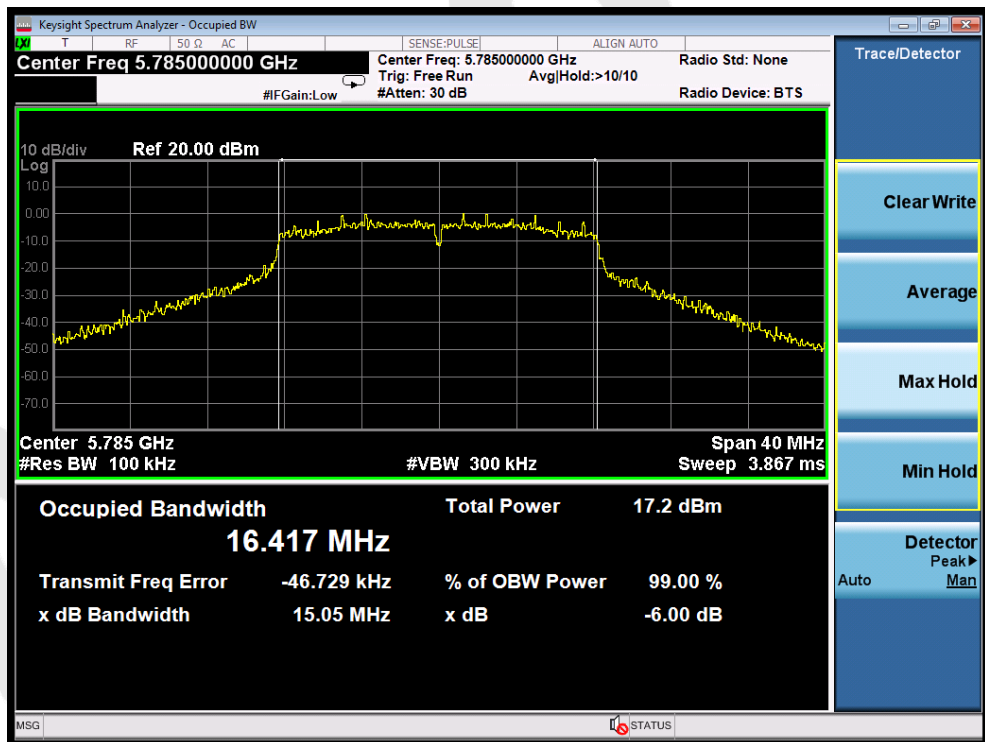

Test Mode: 802.11a---Middle



Test Mode: 802.11a---High

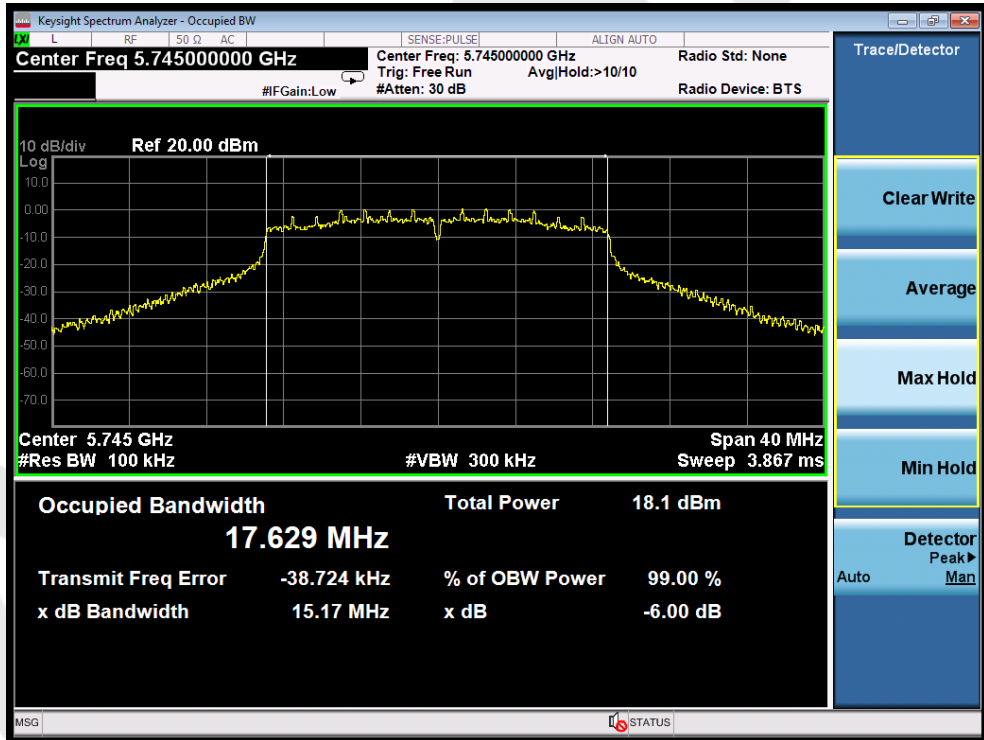

Test Mode: 802.11n20---Low



Test Mode: 802.11n20---Middle

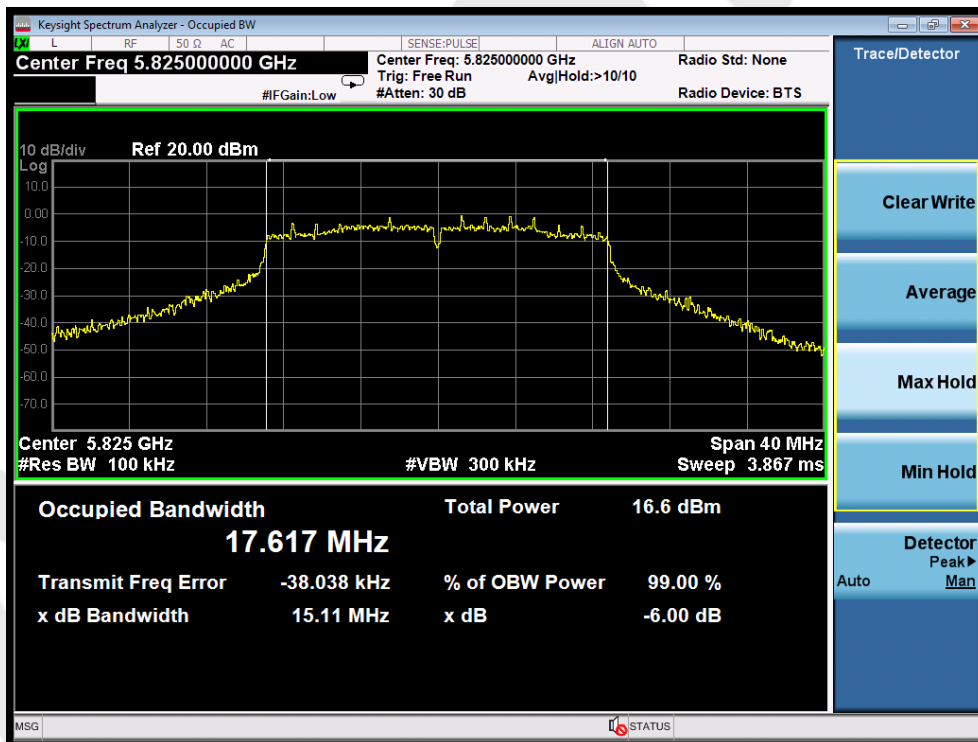

Test Mode: 802.11n20---High

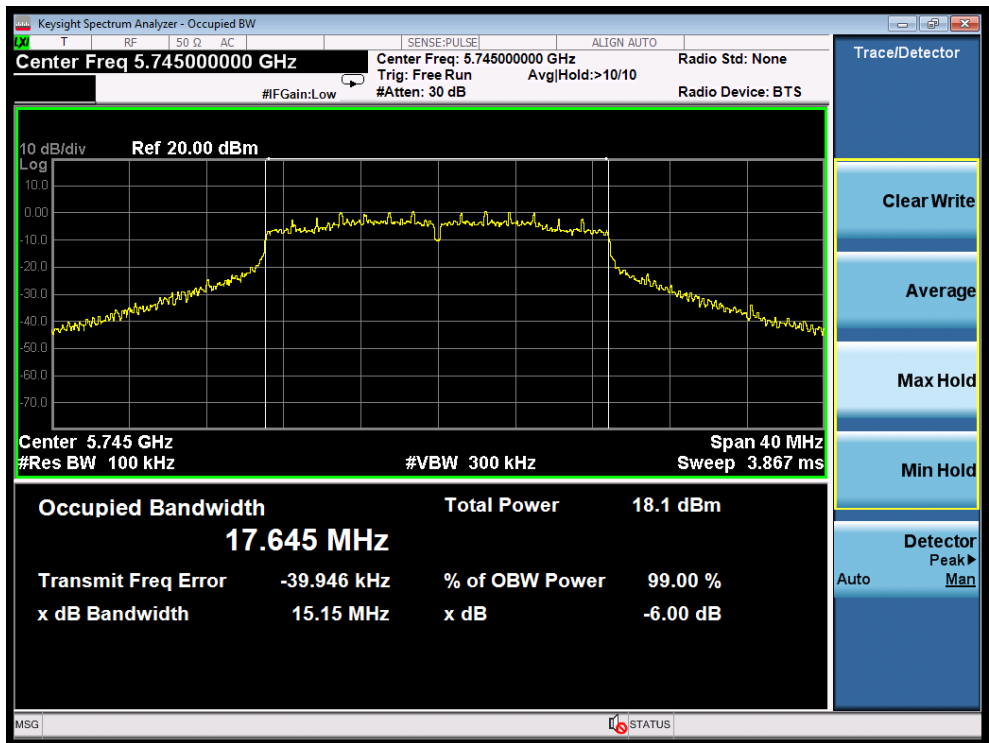

Test Mode: 802.11ac20--Low

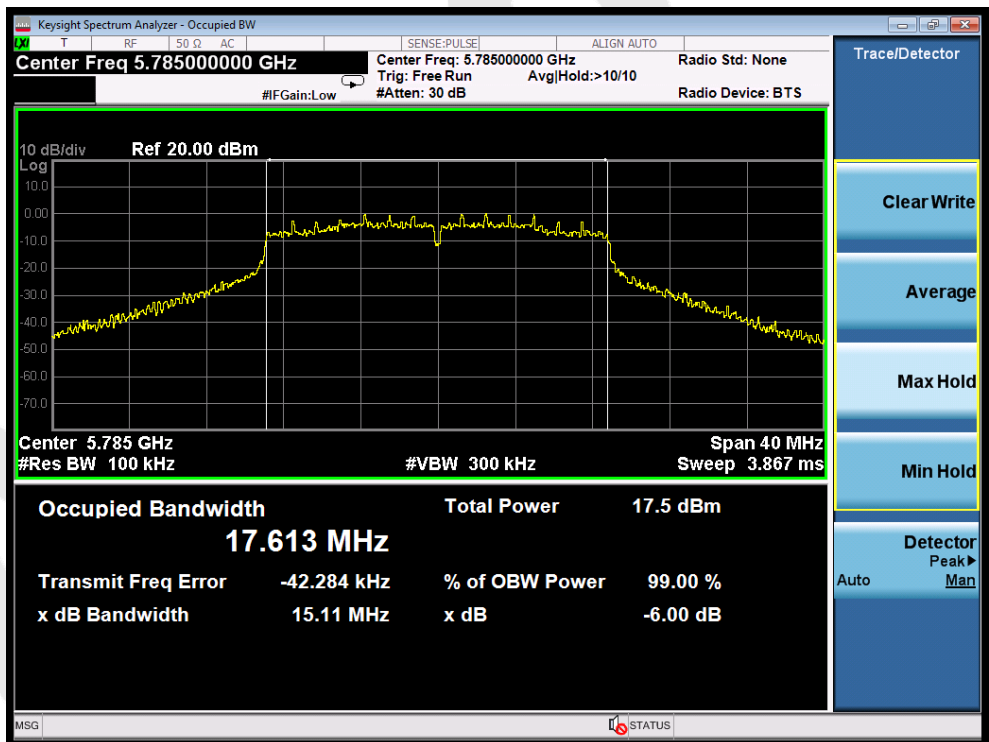

Test Mode: 802.11ac20--Middle

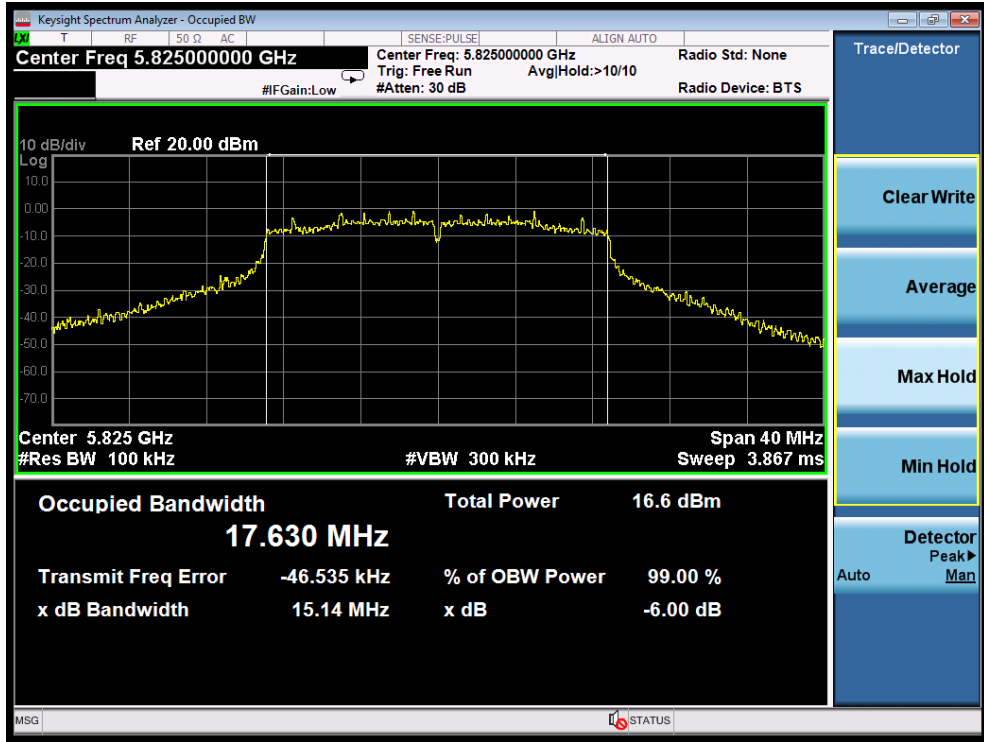

Test Mode: 802.11ac20---High

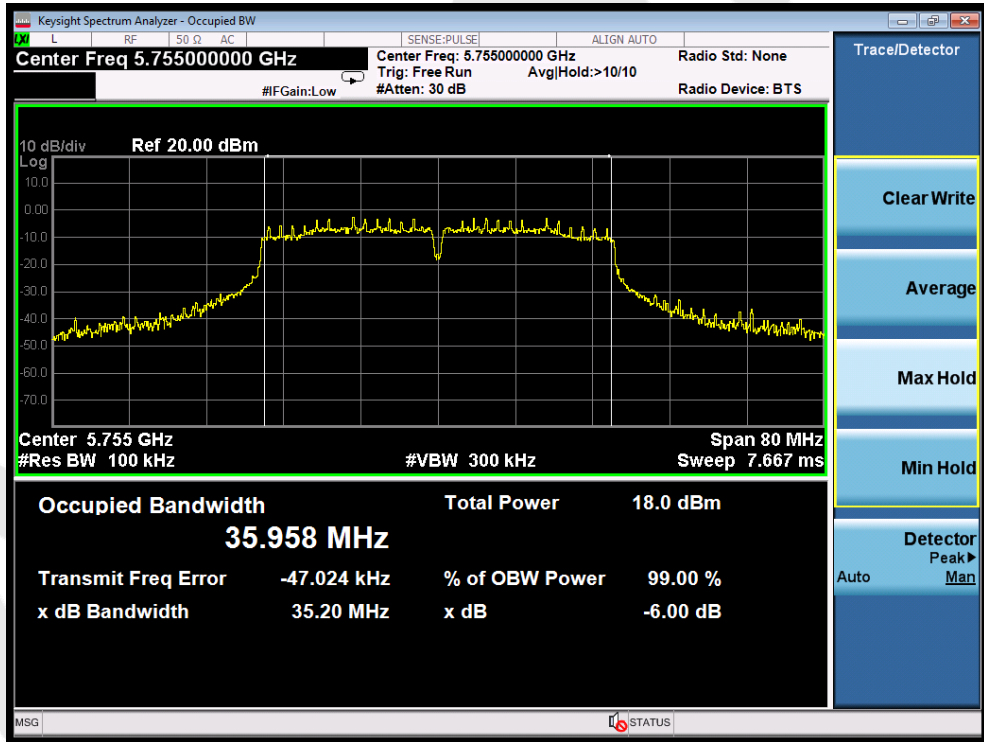

Test Mode: 802.11n40---Low



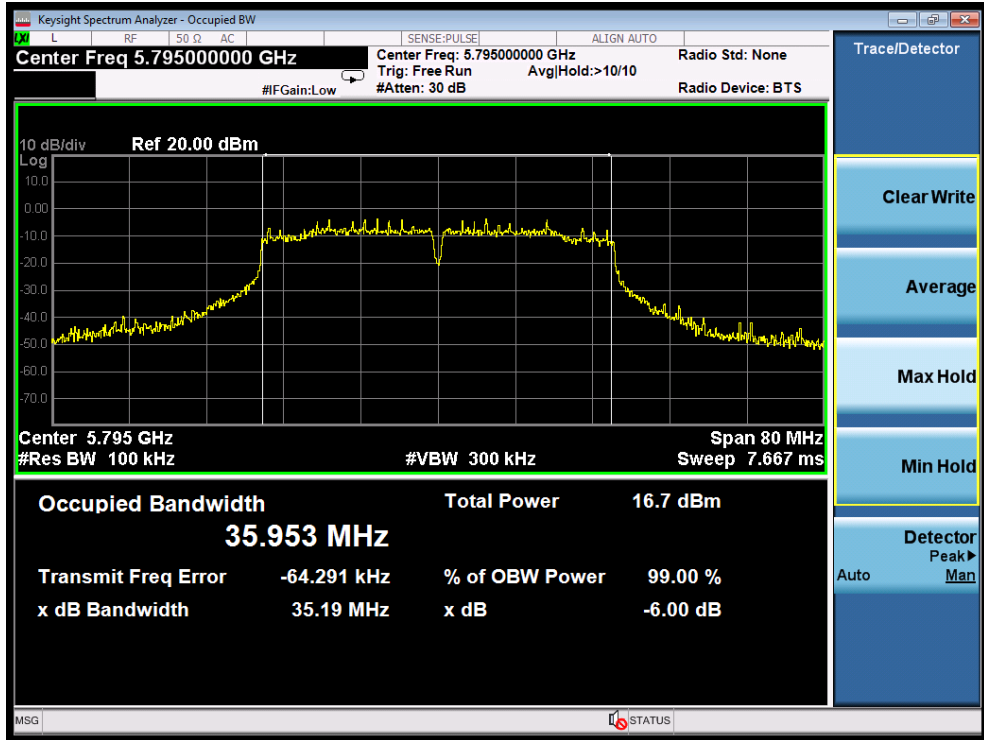

Test Mode: 802.11n40---High

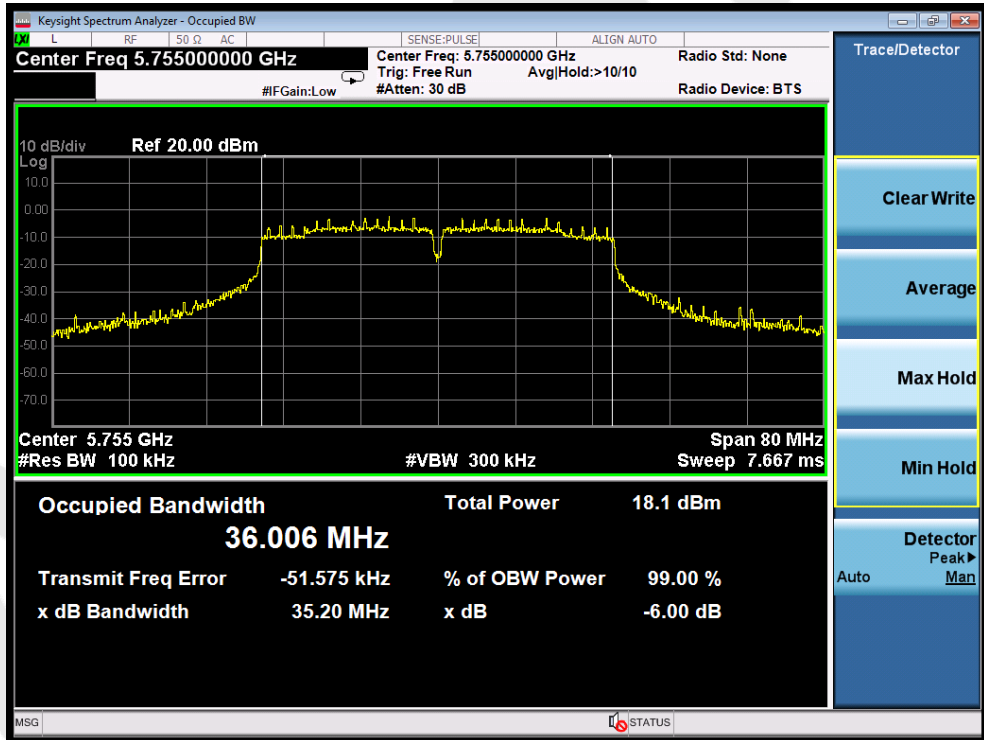

Test Mode: 802.11ac40---Low

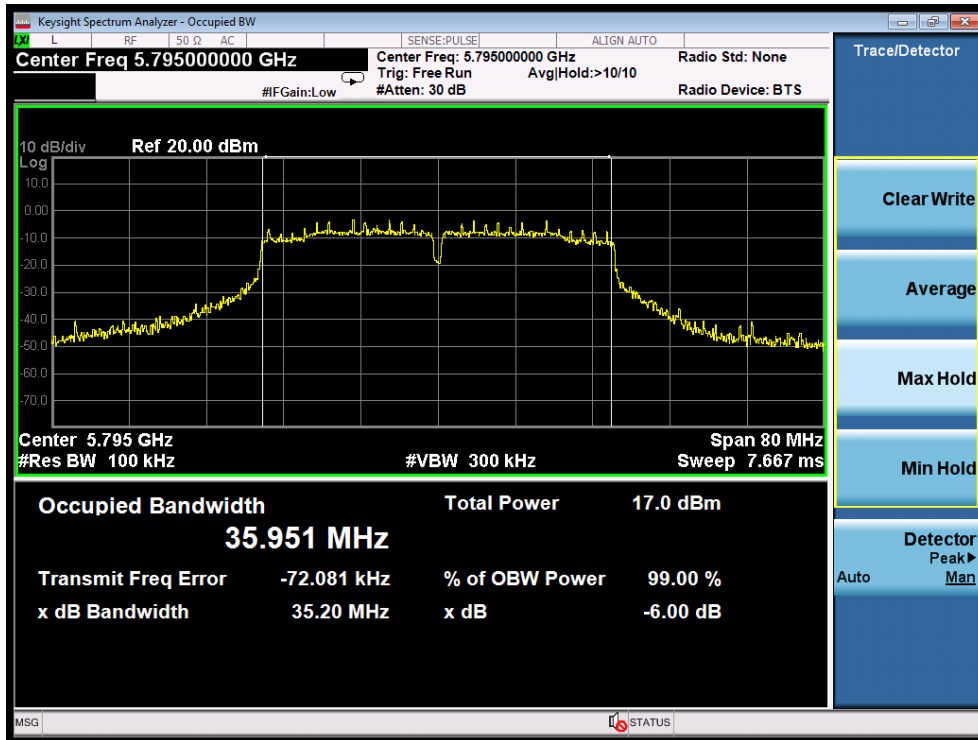

Test Mode: 802.11ac40---High

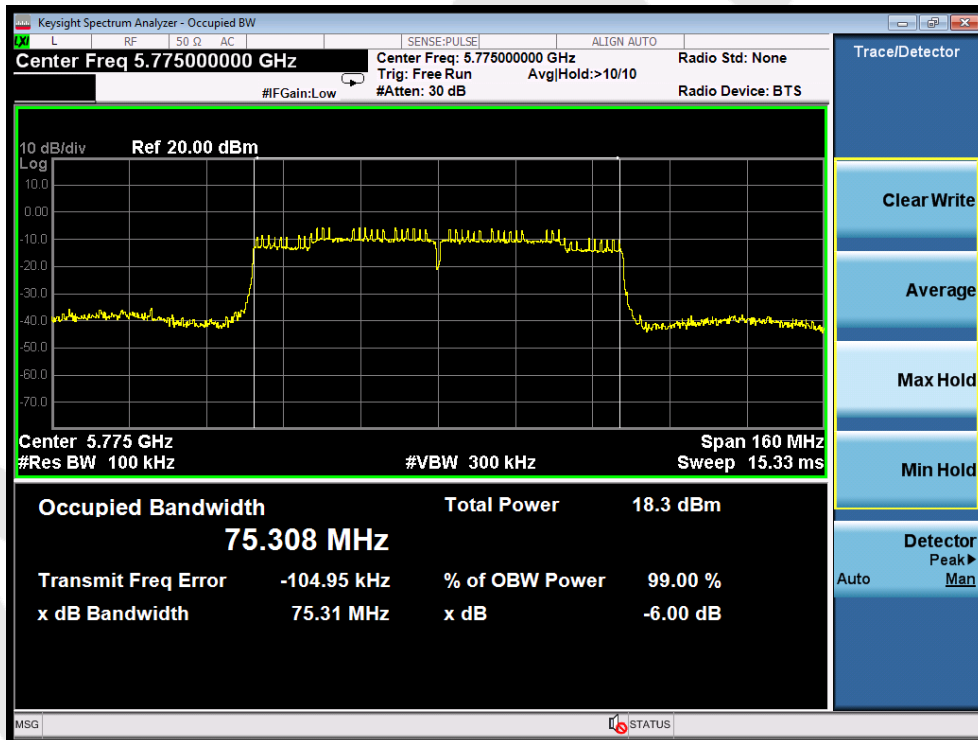

Test Mode: 802.11ac80

**26dB & 99% Bandwidth**

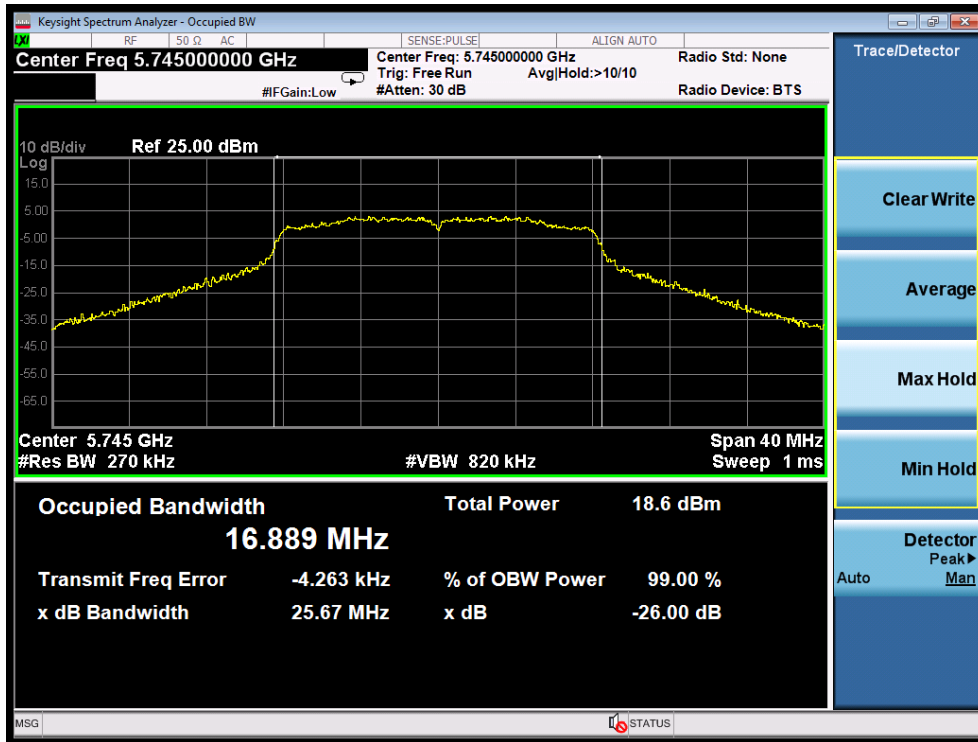

Test Mode: 802.11a--Low



Test Mode: 802.11a---Middle



Test Mode: 802.11a---High

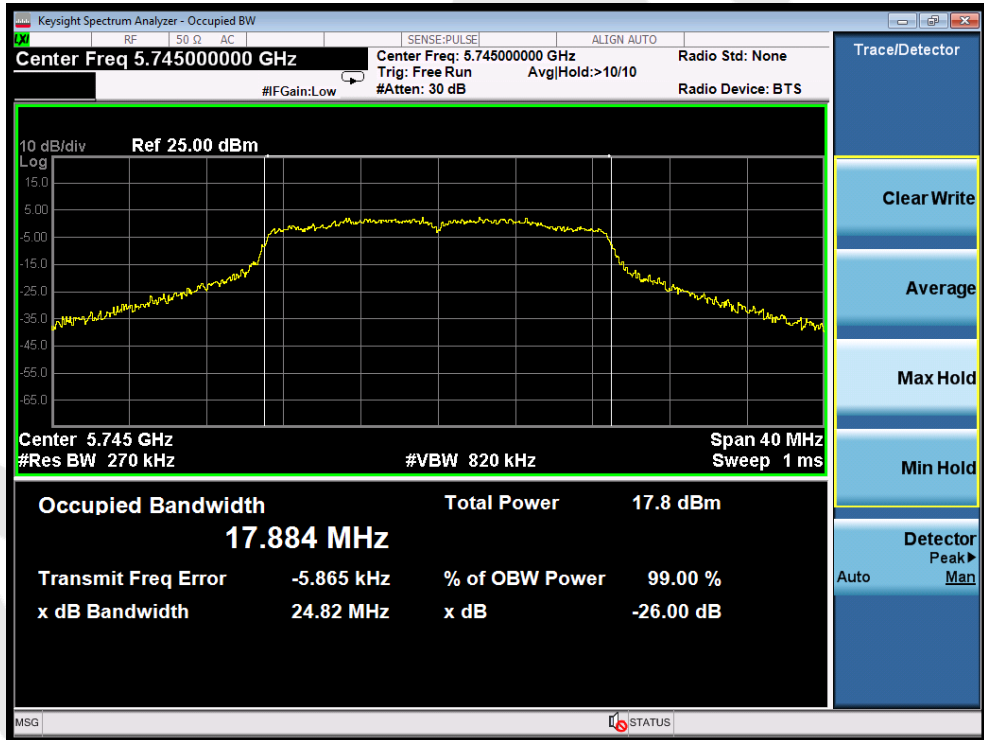

Test Mode: 802.11n20---Low



Test Mode: 802.11n20---Middle



Test Mode: 802.11n20---High

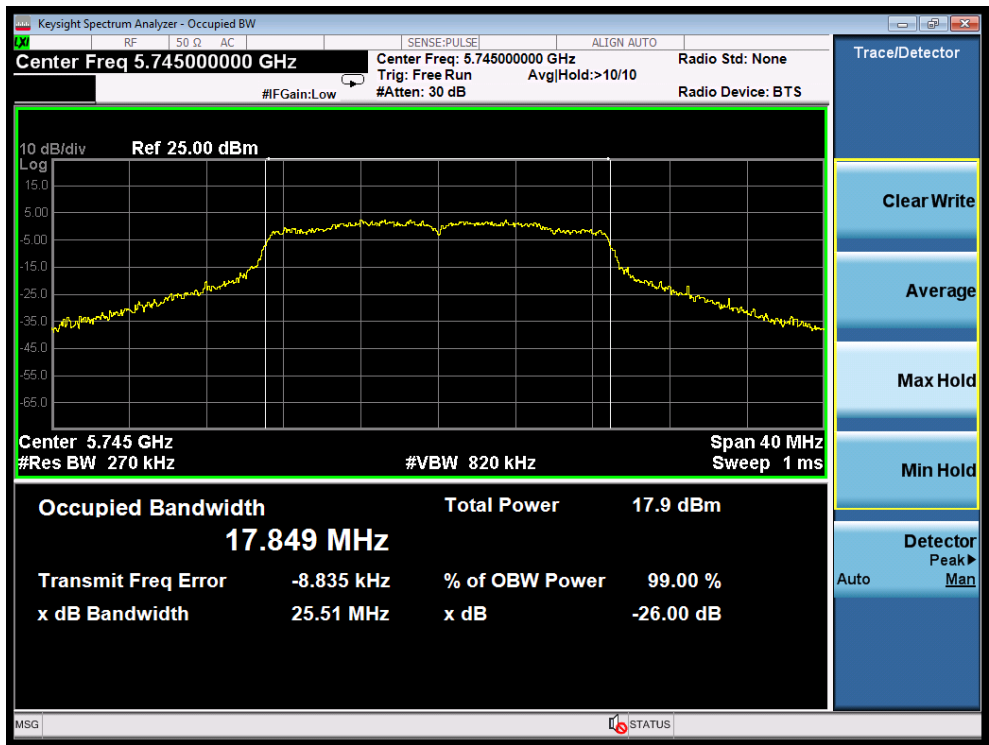

Test Mode: 802.11ac20--Low

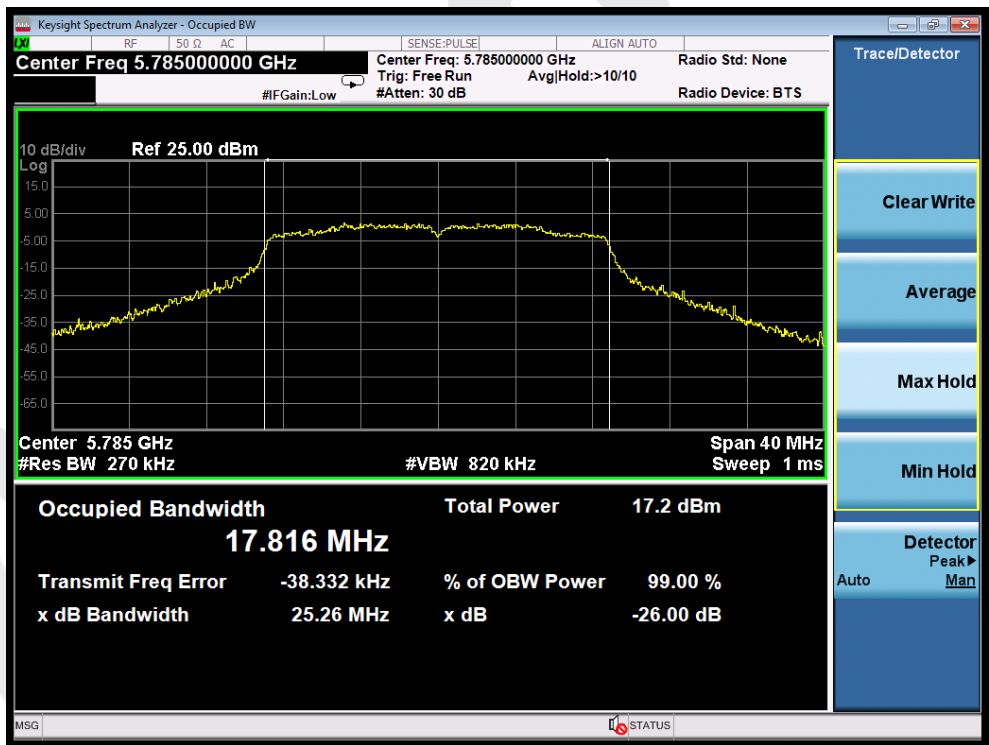

Test Mode: 802.11ac20--Middle

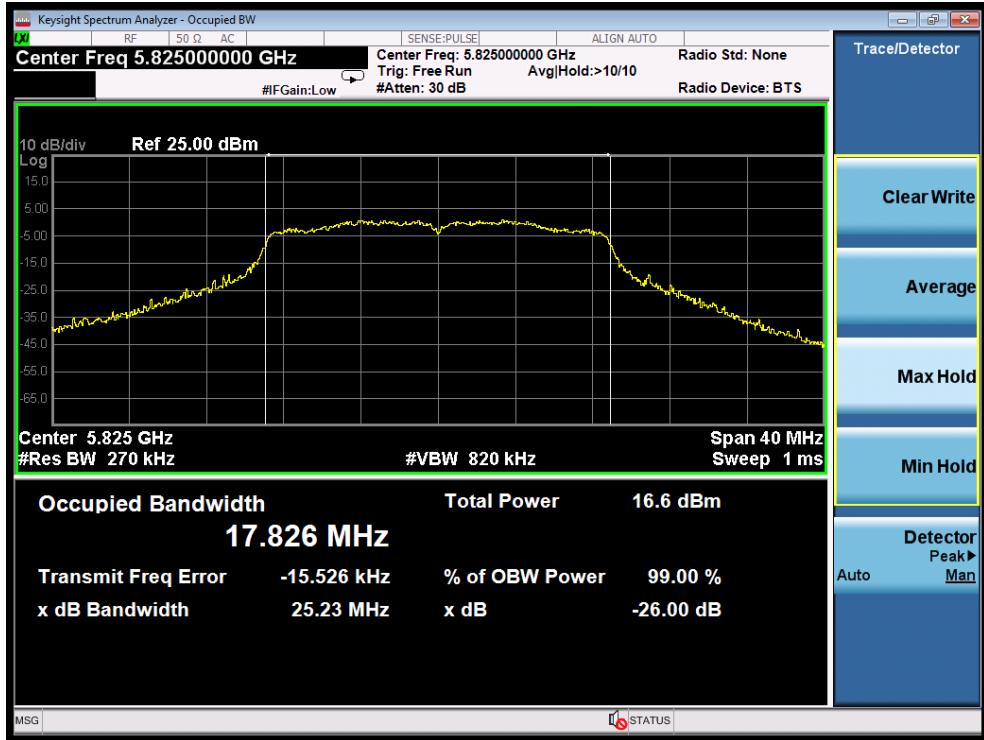

Test Mode: 802.11ac20---High

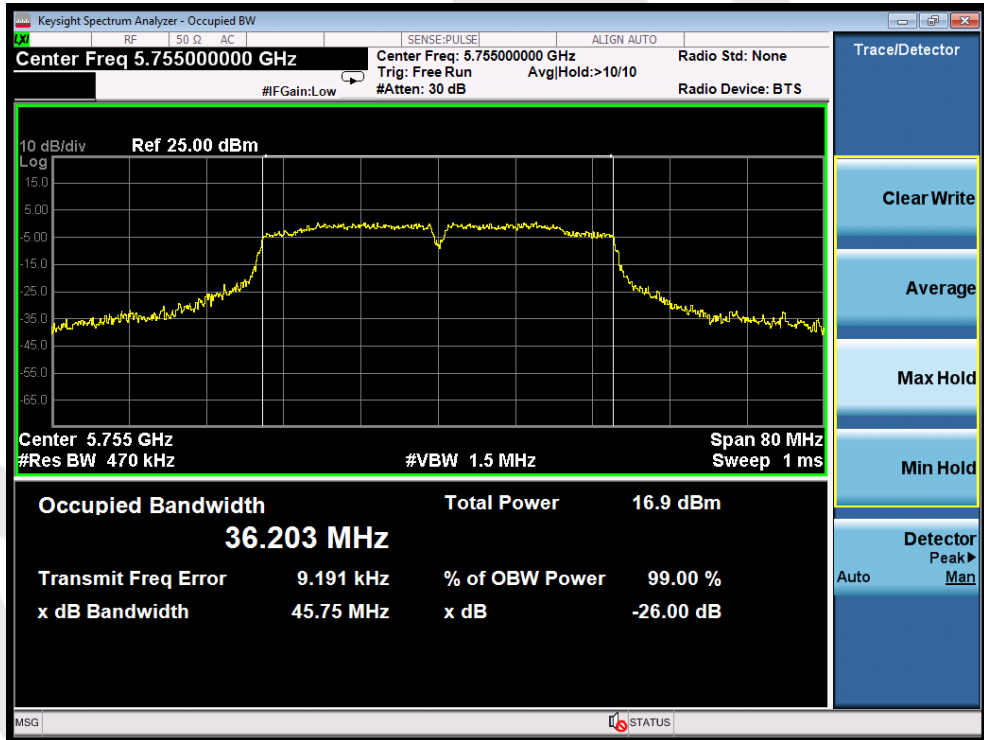

Test Mode: 802.11n40---Low





Test Mode: 802.11n40---High



Test Mode: 802.11ac40---Low



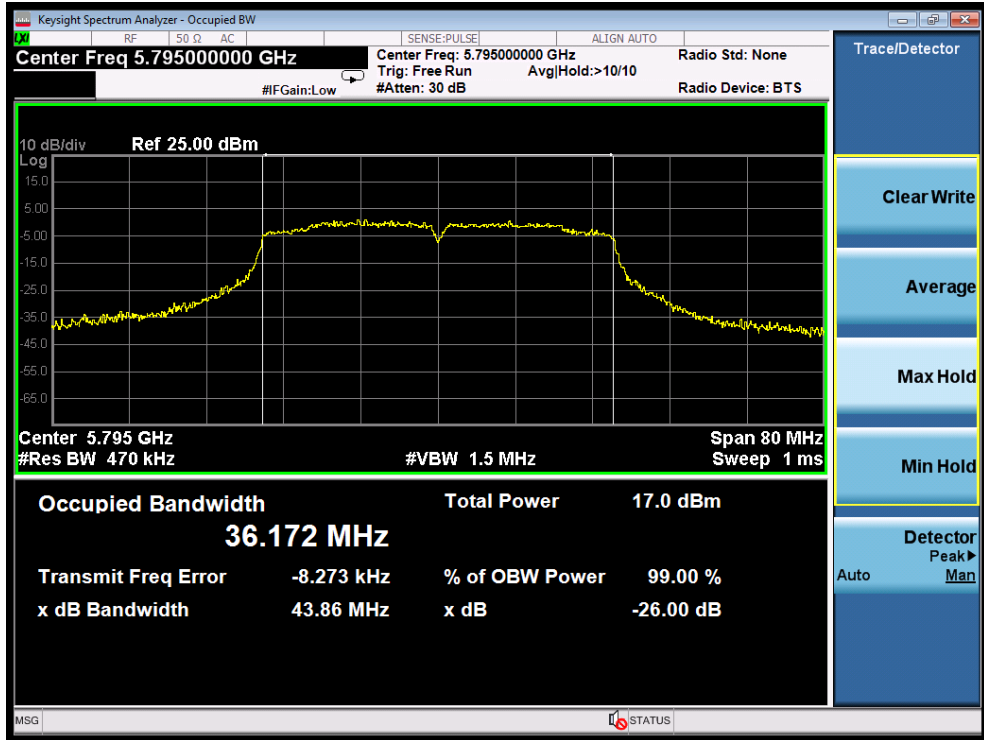

Test Mode: 802.11ac40---High

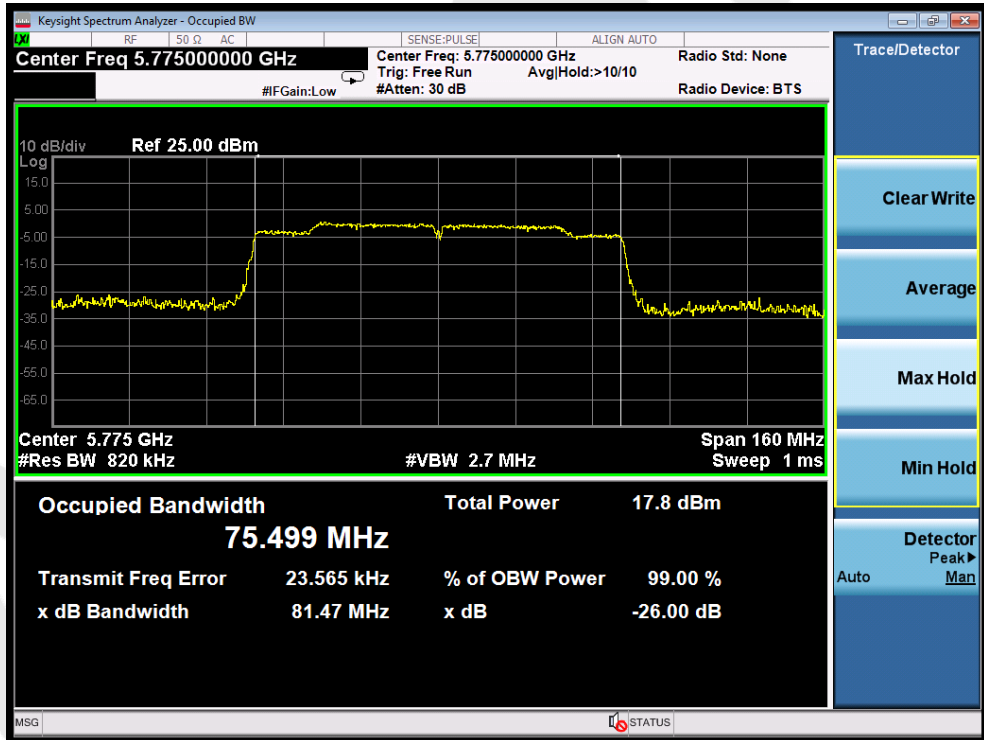

Test Mode: 802.11ac80

**6dB Bandwidth**

ANT 2



Test Mode: 802.11a--Low



Test Mode: 802.11a---Middle



Test Mode: 802.11a---High



Test Mode: 802.11n20---Low

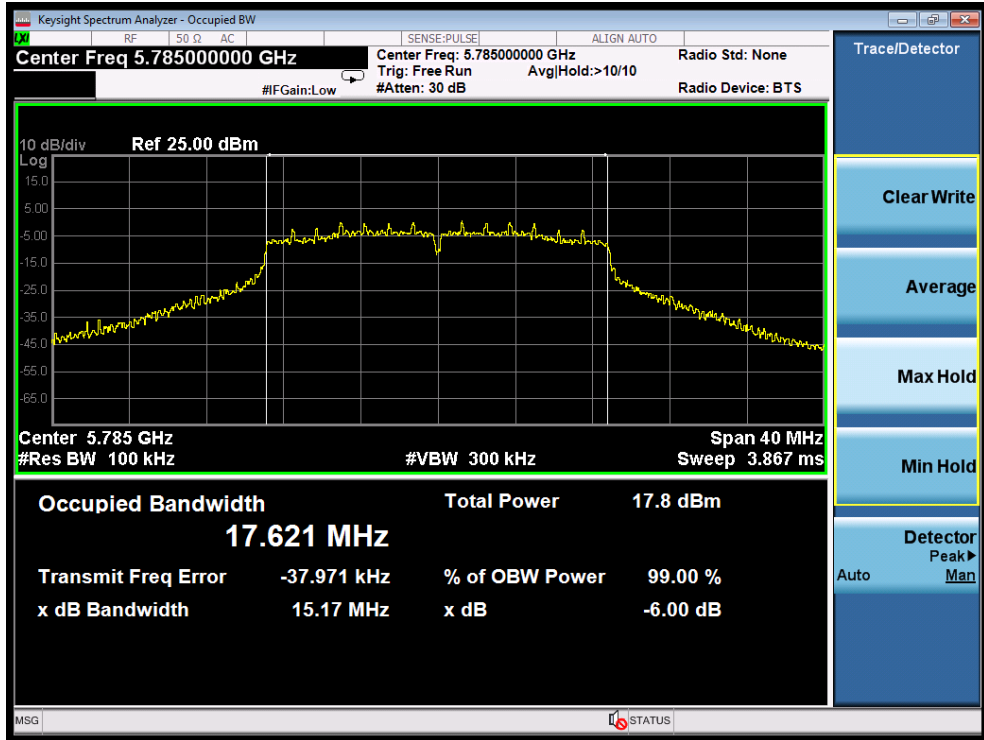

Test Mode: 802.11n20---Middle

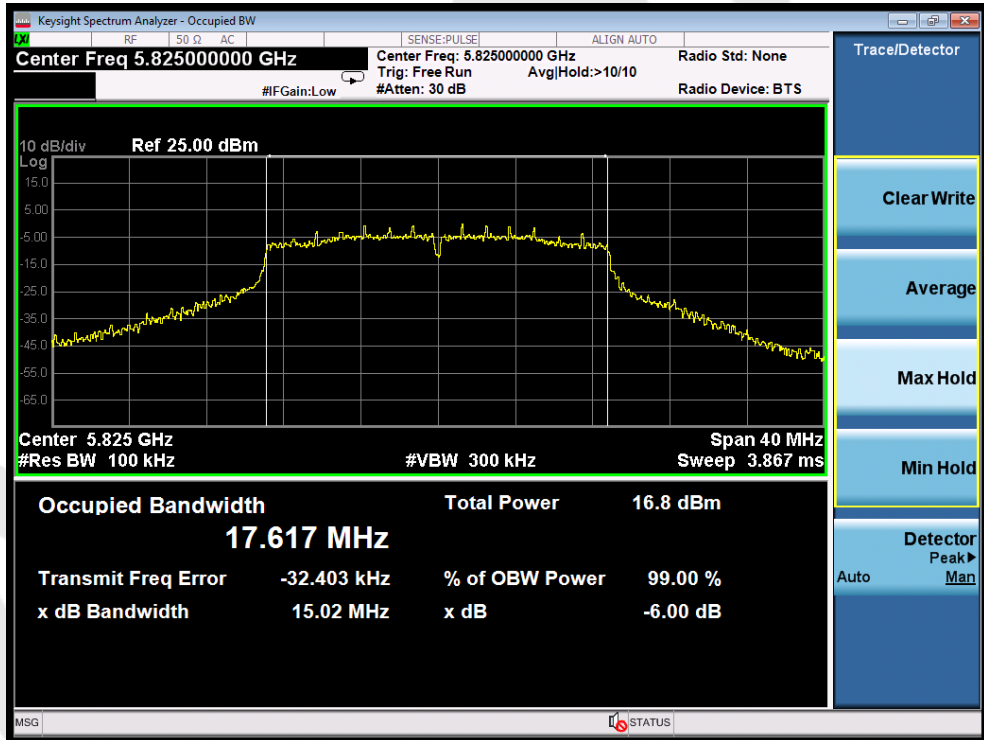

Test Mode: 802.11n20---High

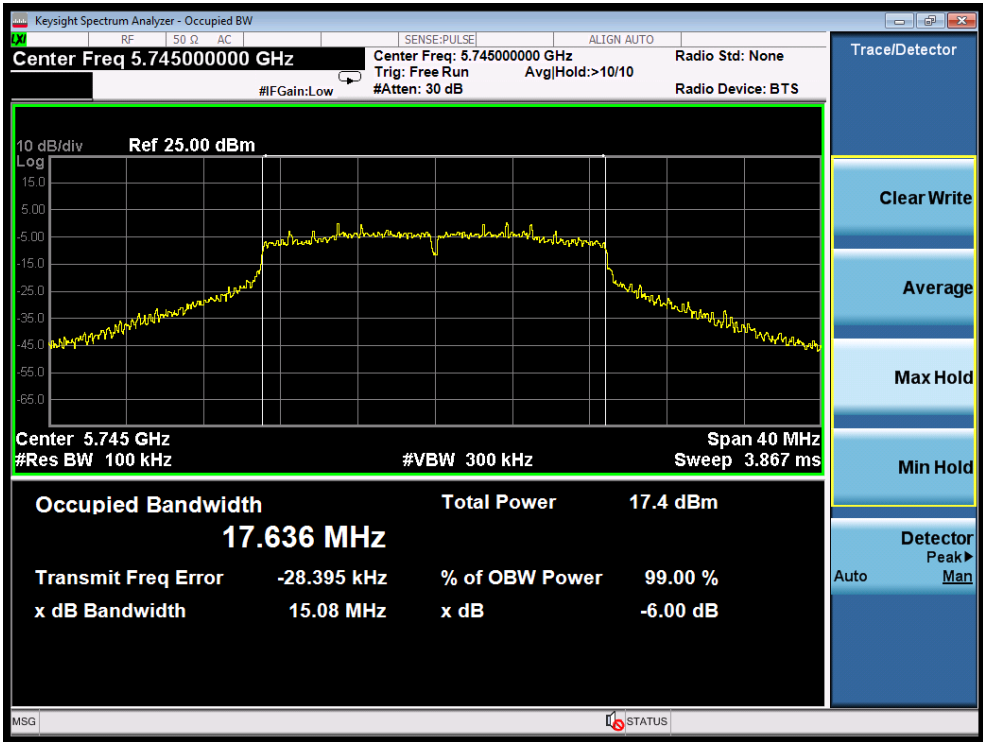

Test Mode: 802.11ac20--Low

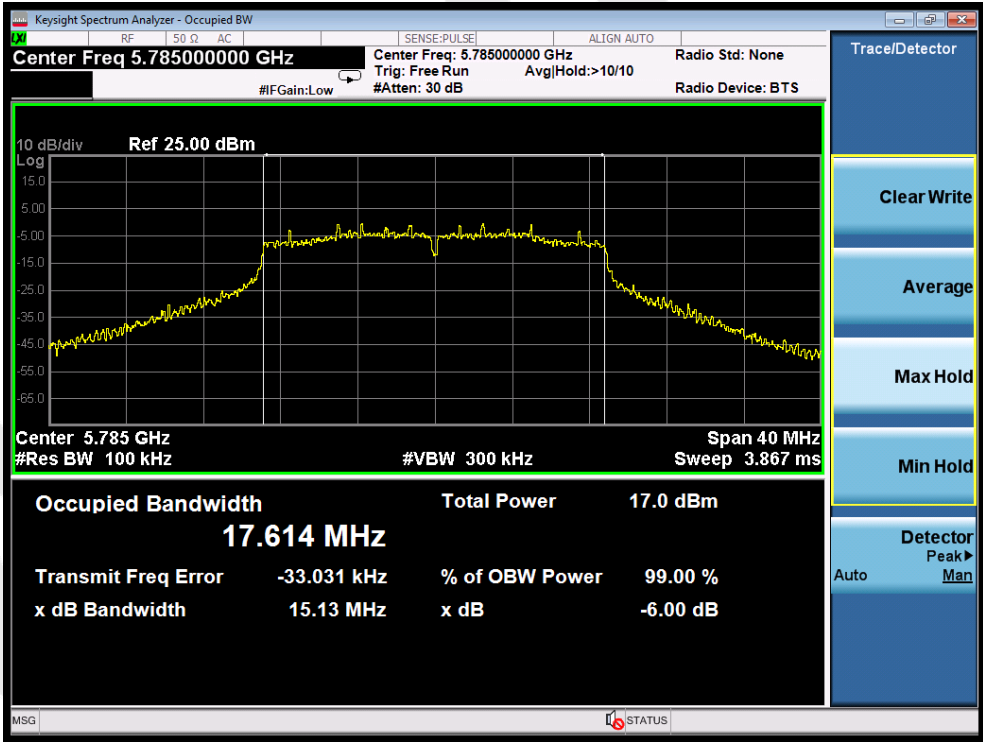

Test Mode: 802.11ac20--Middle

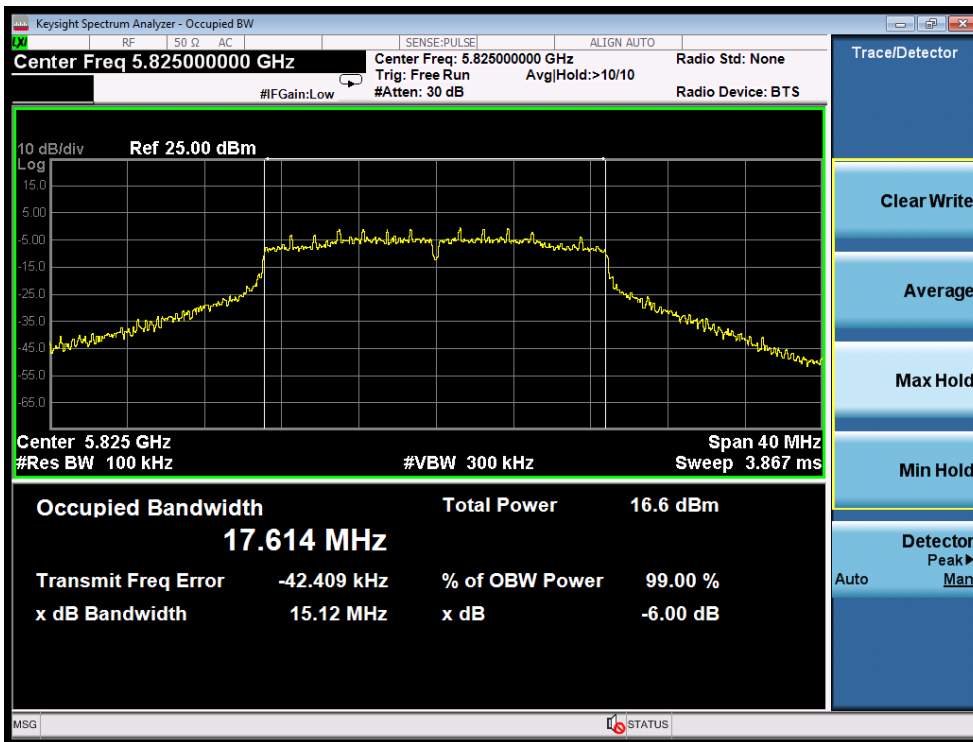

Test Mode: 802.11ac20---High

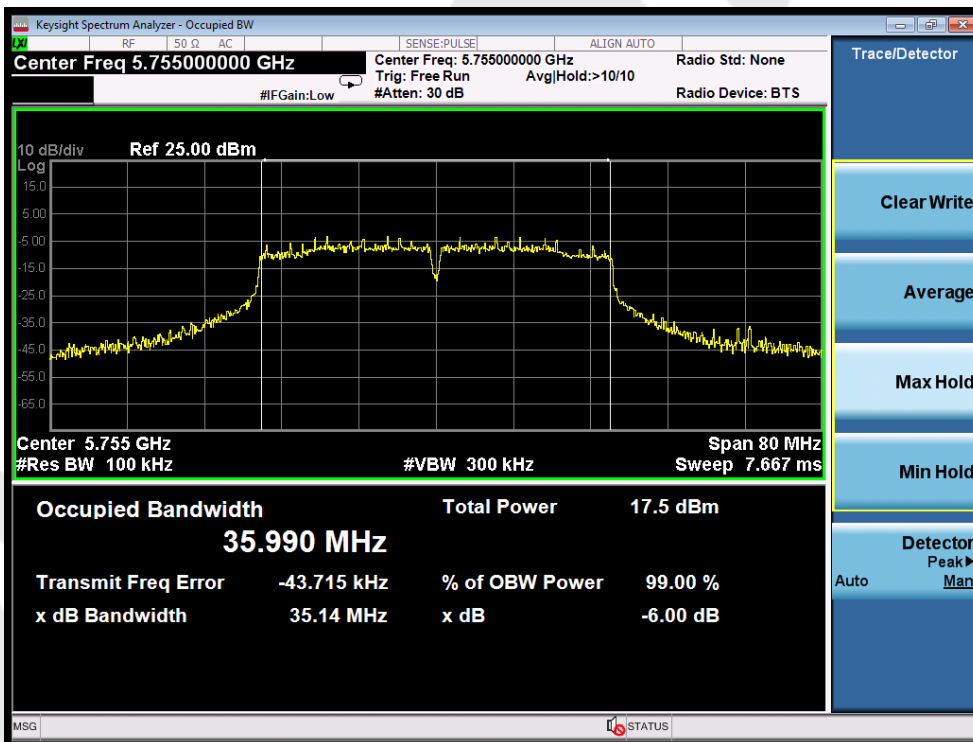

Test Mode: 802.11n40---Low

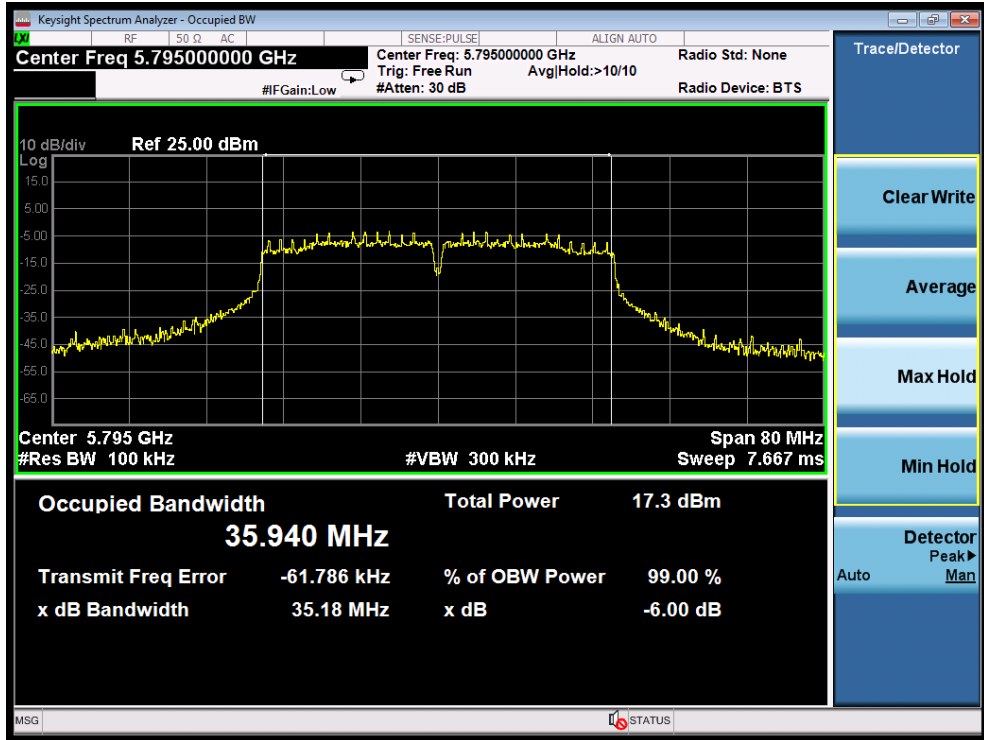

Test Mode: 802.11n40---High

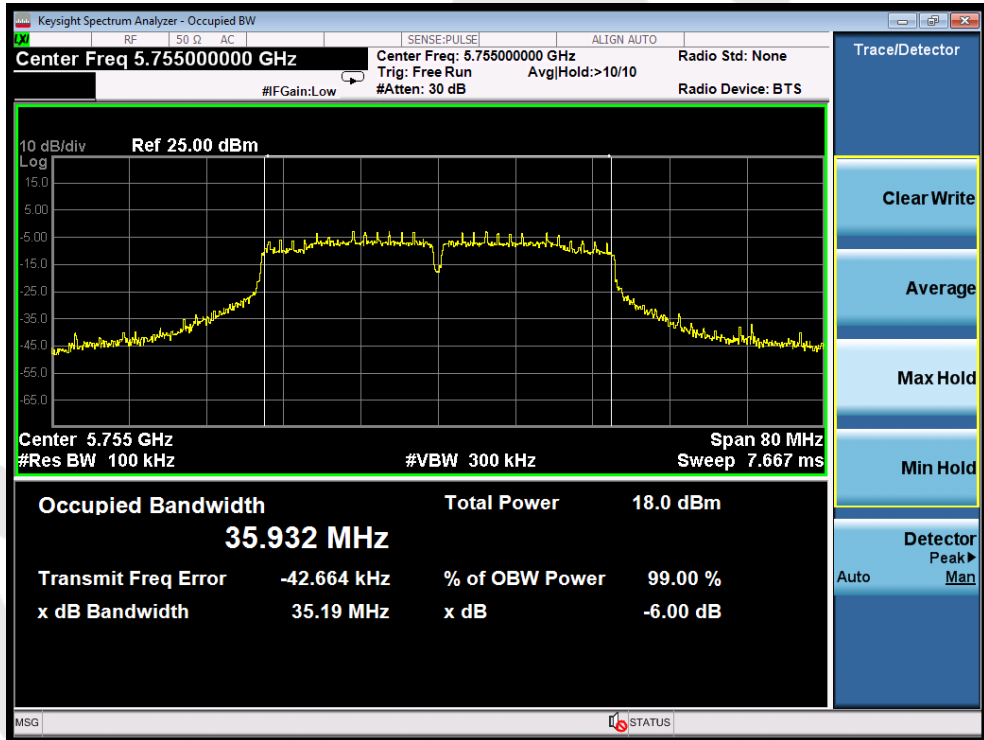

Test Mode: 802.11ac40---Low



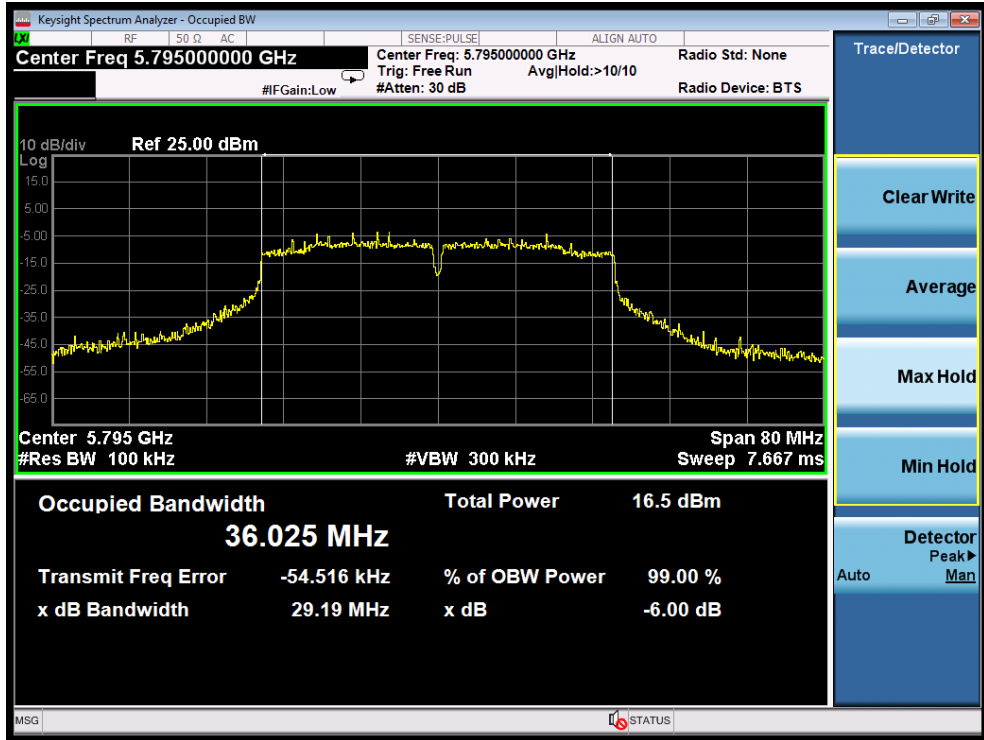

Test Mode: 802.11ac40---High

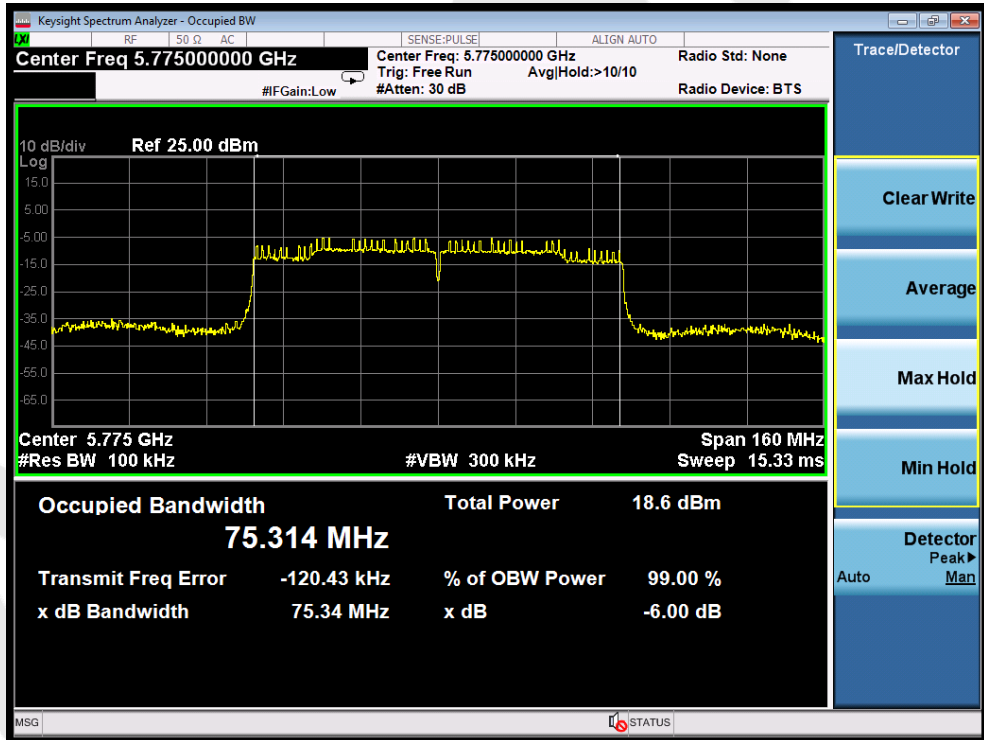

Test Mode: 802.11ac80



**26dB & 99% Bandwidth**

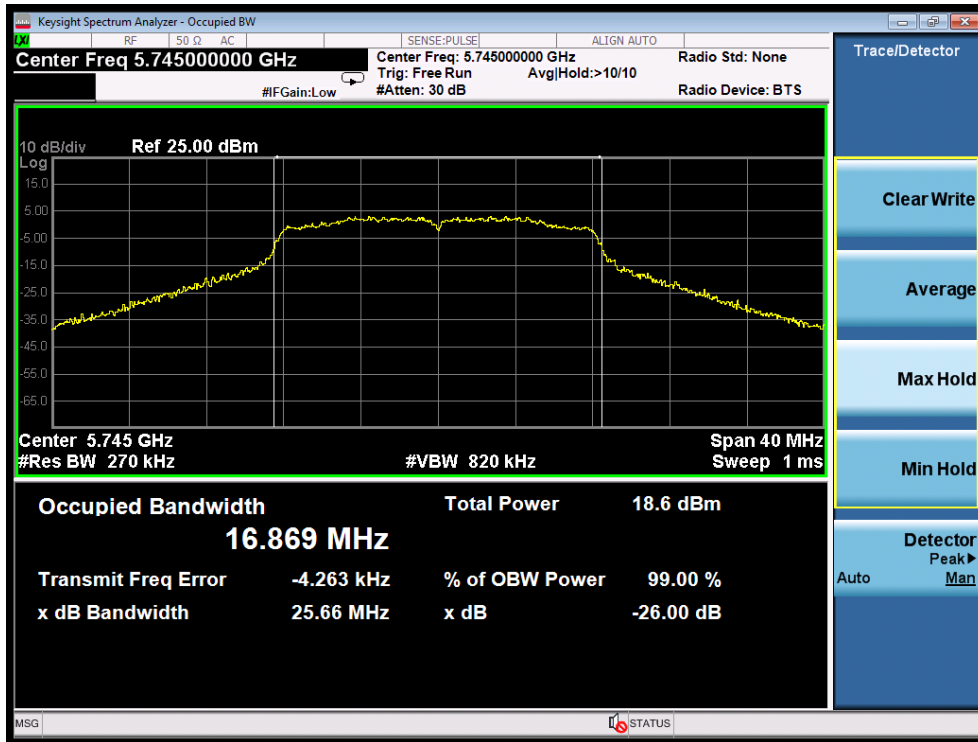

Test Mode: 802.11a--Low



Test Mode: 802.11a---Middle



Test Mode: 802.11a---High

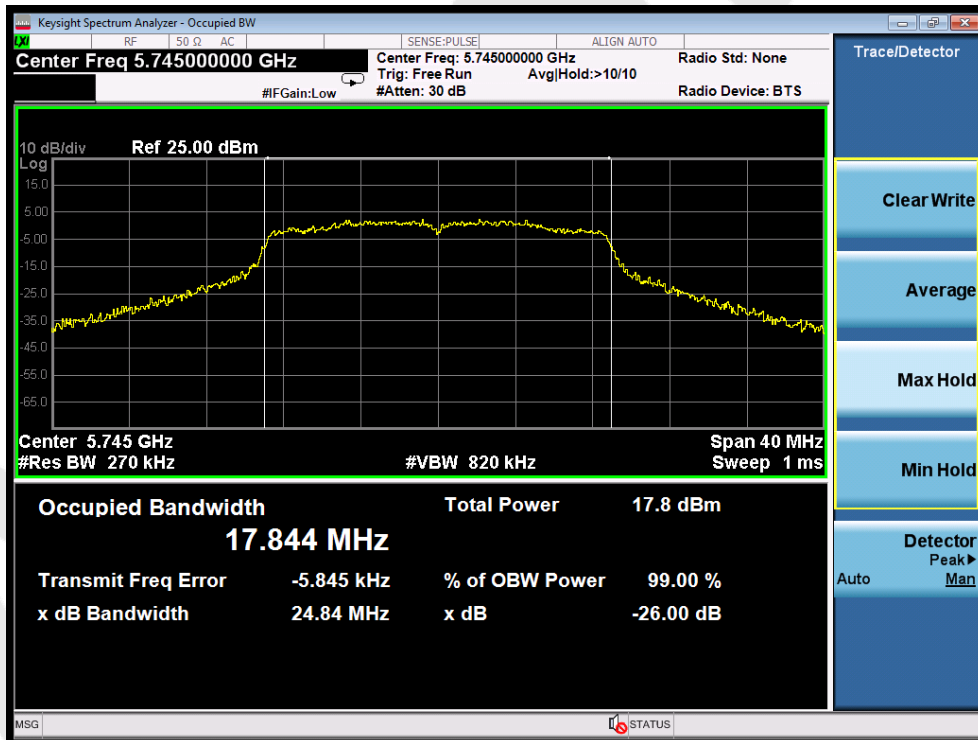

Test Mode: 802.11n20---Low

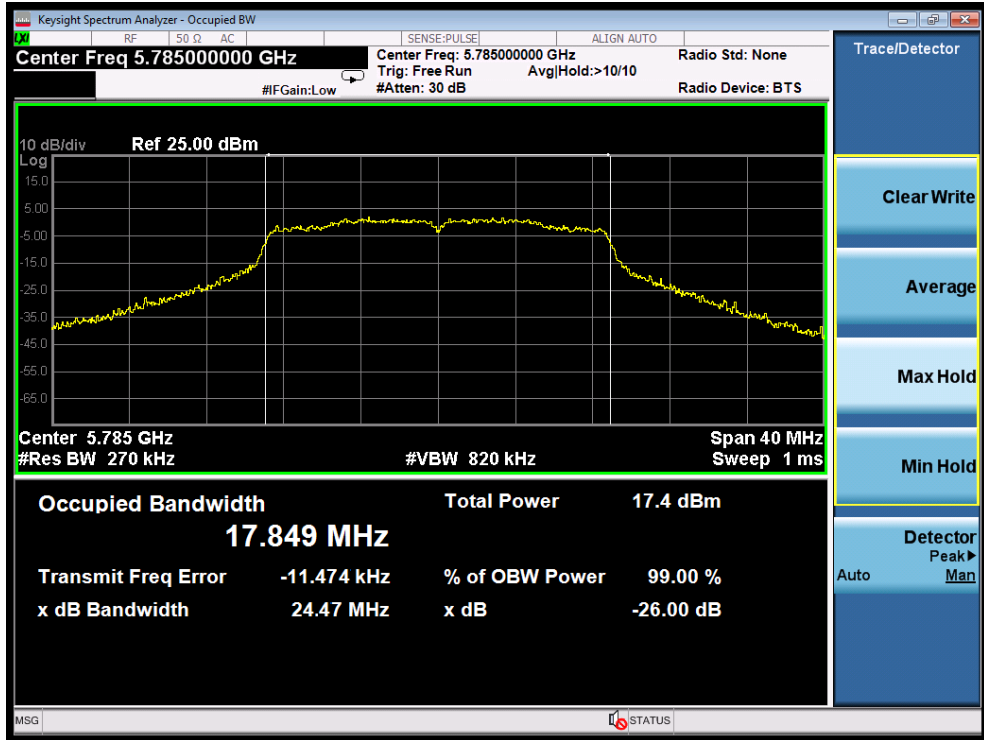

Test Mode: 802.11n20---Middle

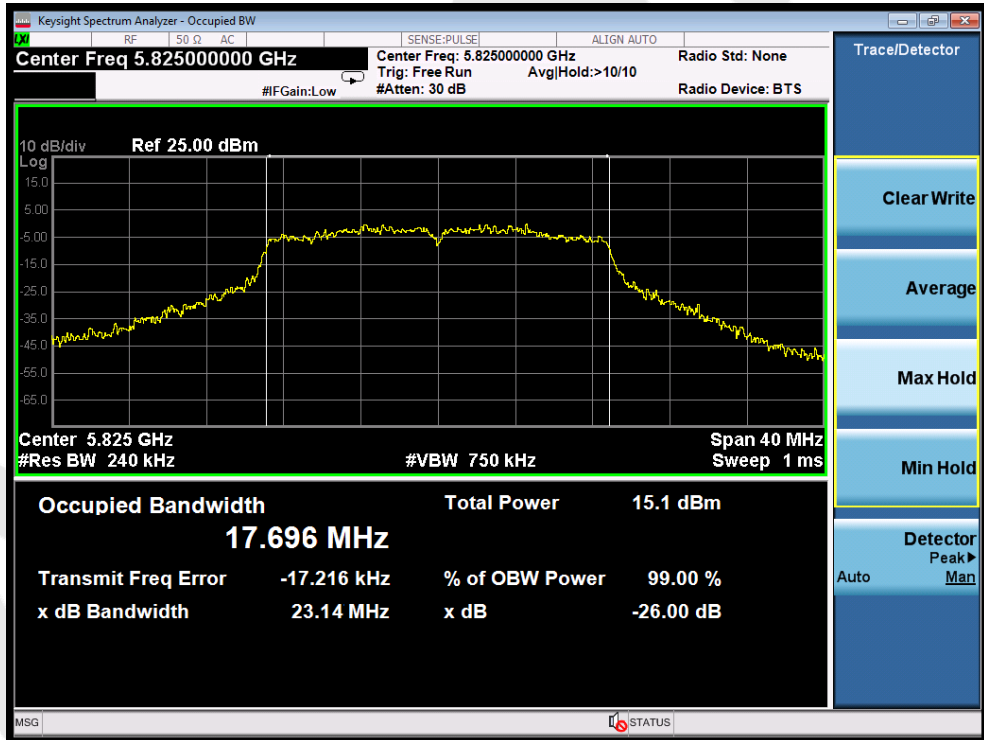

Test Mode: 802.11n20---High

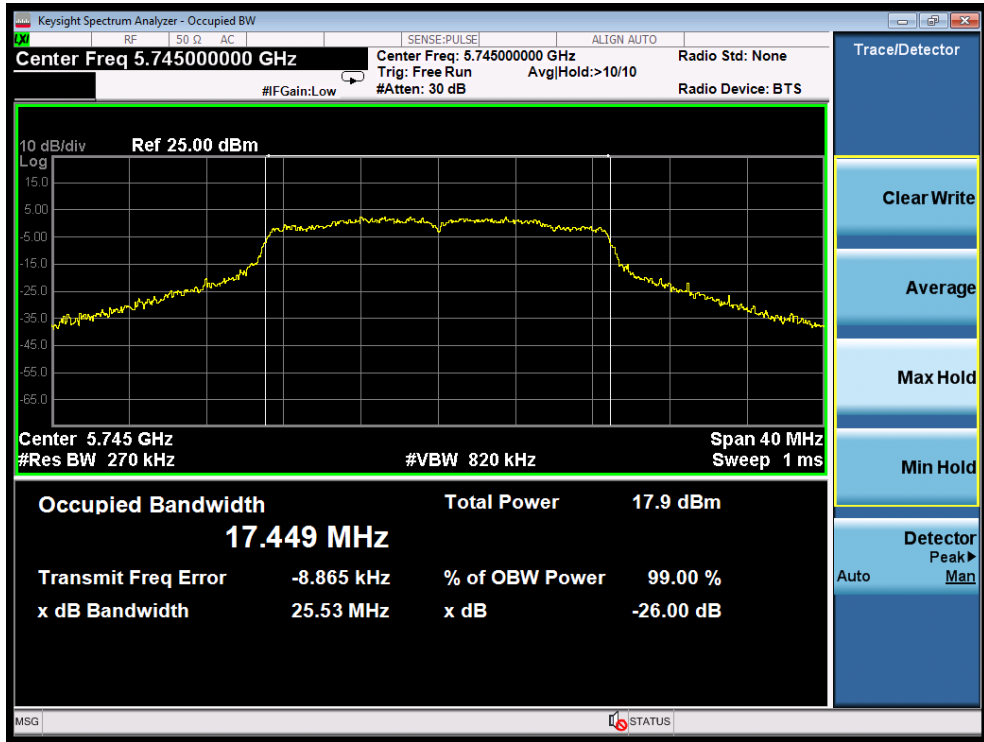

Test Mode: 802.11ac20--Low

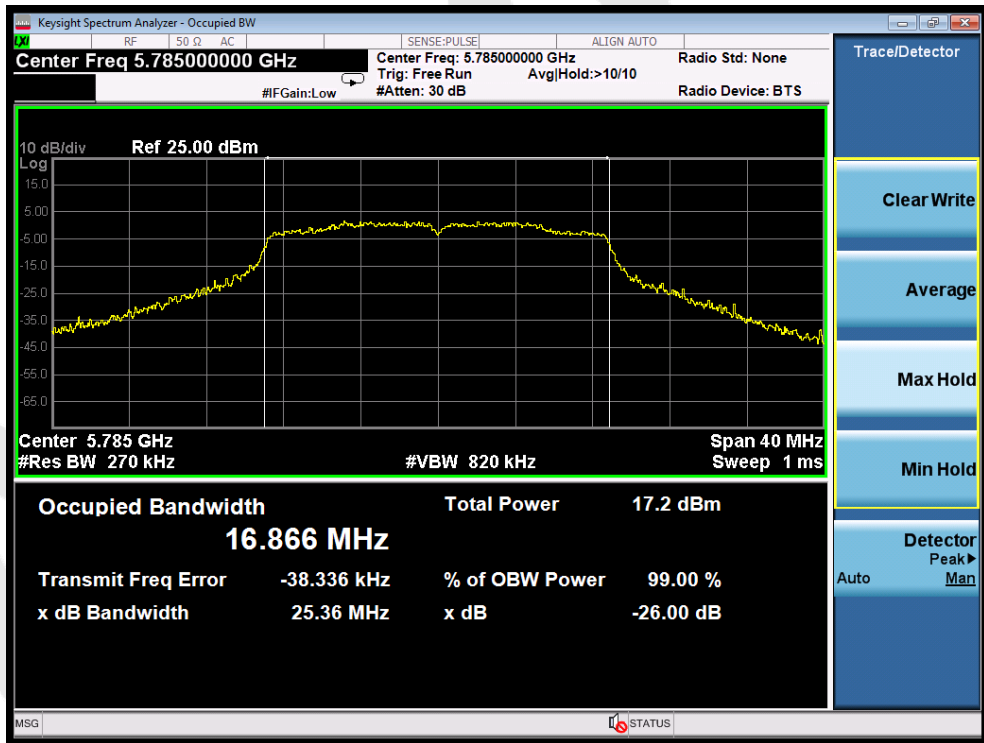

Test Mode: 802.11ac20--Middle



Test Mode: 802.11ac20---High



Test Mode: 802.11n40---Low



Test Mode: 802.11n40---High

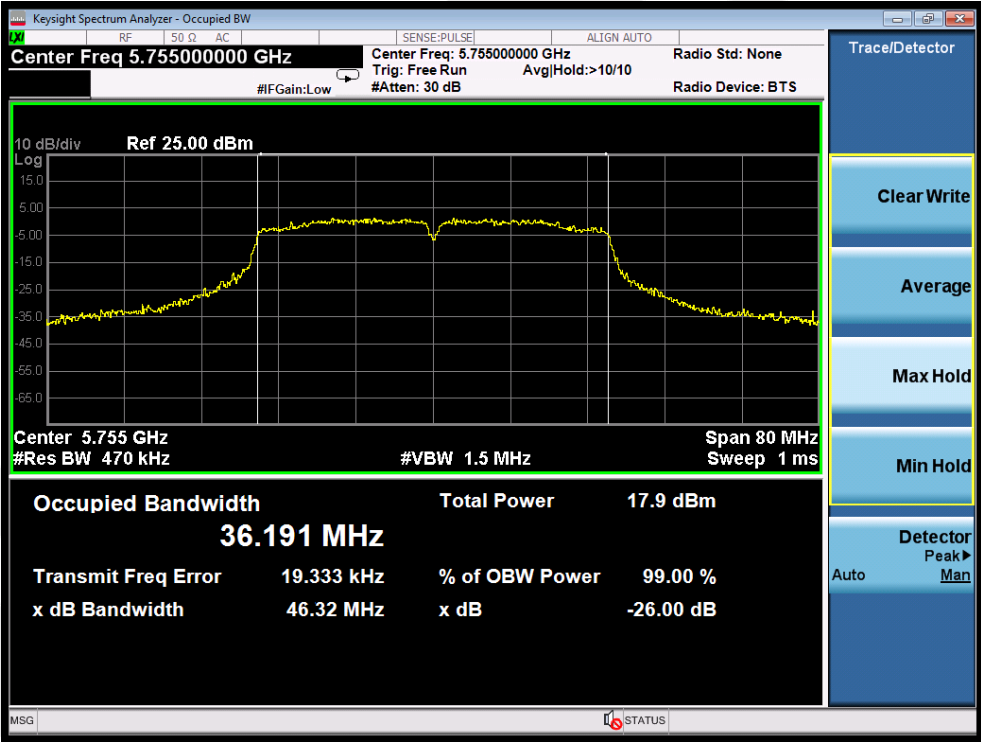

Test Mode: 802.11ac40---Low

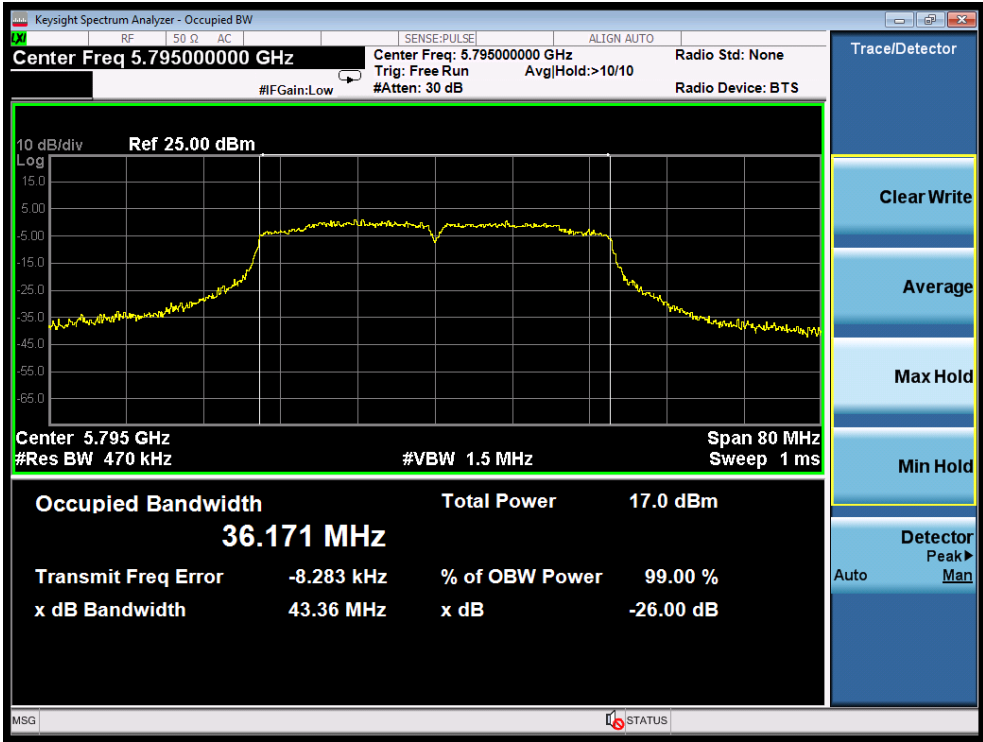

Test Mode: 802.11ac40---High

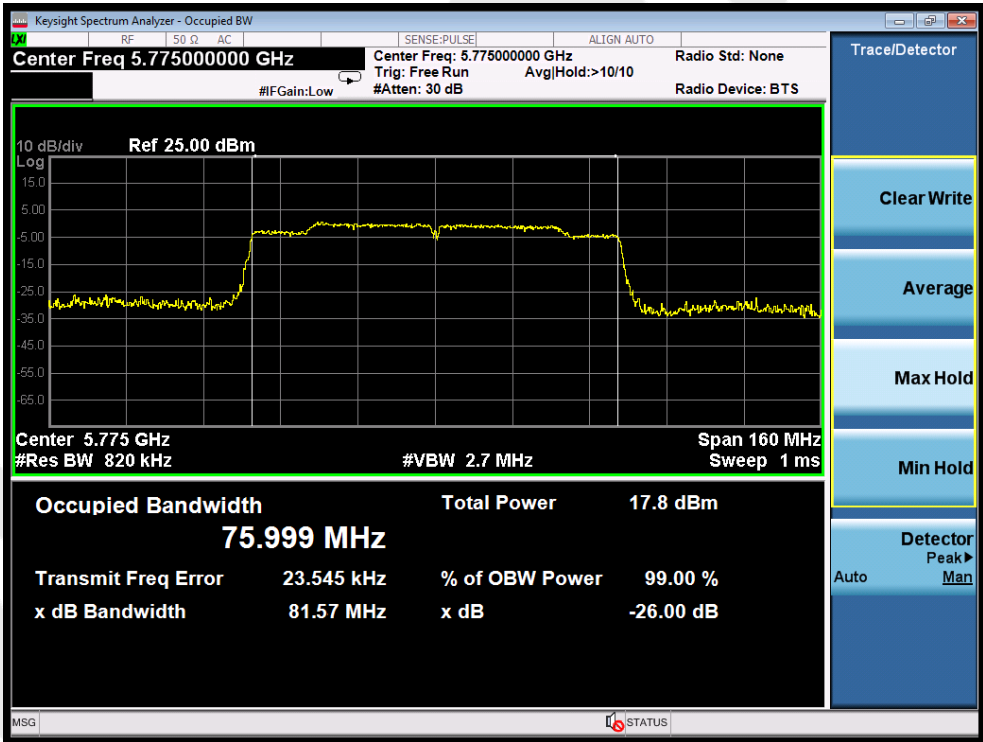

Test Mode: 802.11ac80



## 7. Power Spectral Density Test

### 7.1. Test Standard and Limit

Test Standard	FCC Part15 C Section 15.407 (a) (3)
Test Limit	not exceed 30dBm/500kHz

### 7.2. Test Setup

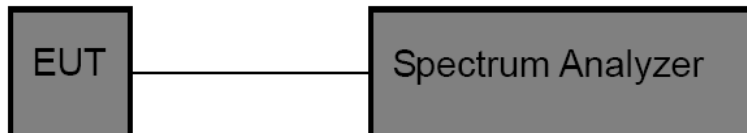

### 7.3. Test Procedure

For devices operating in the bands 5.15-5.25 GHz, 5.25-5.35 GHz, and 5.47-5.725 GHz, the above procedures make use of 1 MHz RBW to satisfy directly the 1 MHz reference bandwidth specified in § 15.407(a)(5). For devices operating in the band 5.725-5.85 GHz, the rules specify a measurement bandwidth of 500 kHz. Many spectrum analyzers do not have 500 kHz RBW, thus a narrower RBW may need to be used. The rules permit the use of a RBWs less than 1 MHz, or 500 kHz, “provided that the measured power is integrated over the full reference bandwidth” to show the total power over the specified measurement bandwidth (i.e., 1 MHz, or 500 kHz).

1. The EUT is directly connected to the spectrum analyzer;
2. Set RBW =510KHz;
3. Set VBW ≥ 3 RBW;
3. Set the span to encompass the entire emissions bandwidth (EBW) of the signal;
5. Detector=RMS;
6. Sweep time= auto couple;
7. Trace mode=max. hold;

### 7.4. Test Data



Test Item	: Power Spectral Density	Test Mode	: CH Low ~ CH High
Test Voltage	: AC 120V/60HZ	Temperature	: 24°C
Test Result	: PASS	Humidity	: 55%RH

Test Mode	Channel Frequency (MHz)	Final Power Spectral Density (dBm)			Correctional Limit (dBm)	Results
		ANT1	ANT2	SUM		
802.11a	5745	<b>6.030</b>	5.476		29.0	PASS
	5785	5.180	5.259		29.0	PASS
	5825	3.661	5.266		29.0	PASS
802.11n20	5745	5.375	5.979	8.00	25.9	PASS
	5785	4.972	5.014	7.74	25.9	PASS
	5825	4.350	5.078	8.77	25.9	PASS
802.11ac20	5745	5.963	5.543	8.04	25.9	PASS
	5785	4.798	5.248	7.23	25.9	PASS
	5825	4.725	3.647	5.42	25.9	PASS
802.11n40	5755	2.146	2.650	4.55	25.9	PASS
	5795	1.324	1.745	5.06	25.9	PASS
802.11ac40	5755	2.221	1.861	4.09	25.9	PASS
	5795	0.853	1.299	1.86	25.9	PASS
802.11ac80	5775	-1.130	-1.172	3.01	25.9	PASS

**Note:**

For 802.11a/n20/ac20 mode,  
Power limit Reduction=7-6=1dBi  
Correctional limit=30-1=29dBm

For 802.11n20/n40 mode,  
Directional gain=GANT +10log(N)dBi =7+10log2=10.1dBi  
PSD limit Reduction=10.1-6=4.1dBi  
Correctional limit=30-4.1=25.9dBm

ANT 1

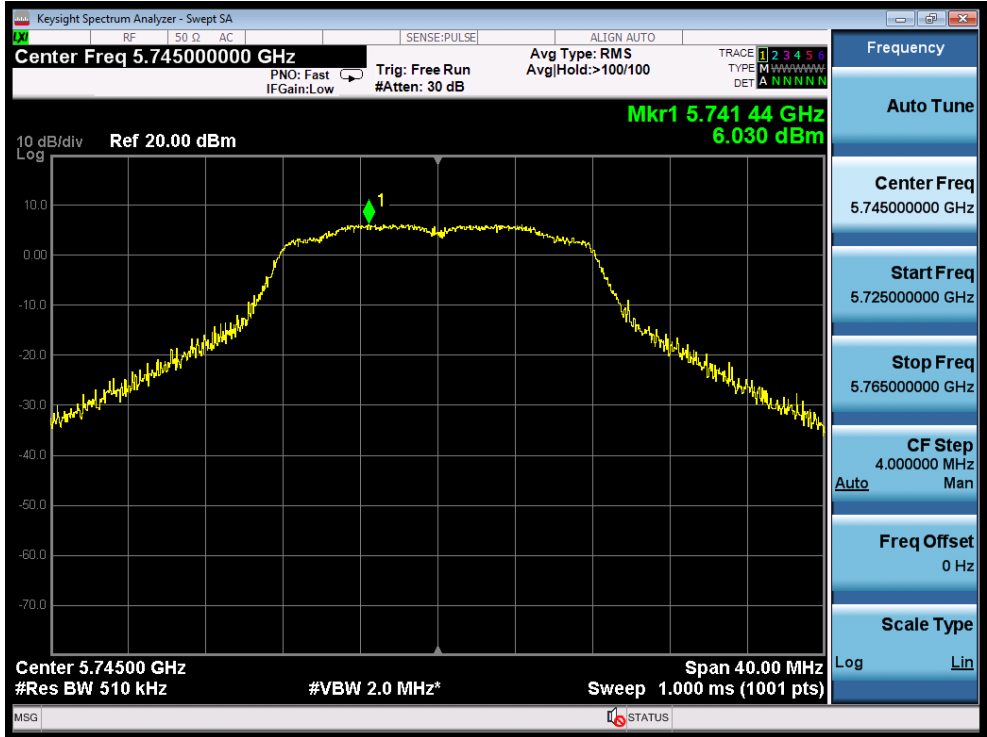

Test Mode: 802.11a--Low

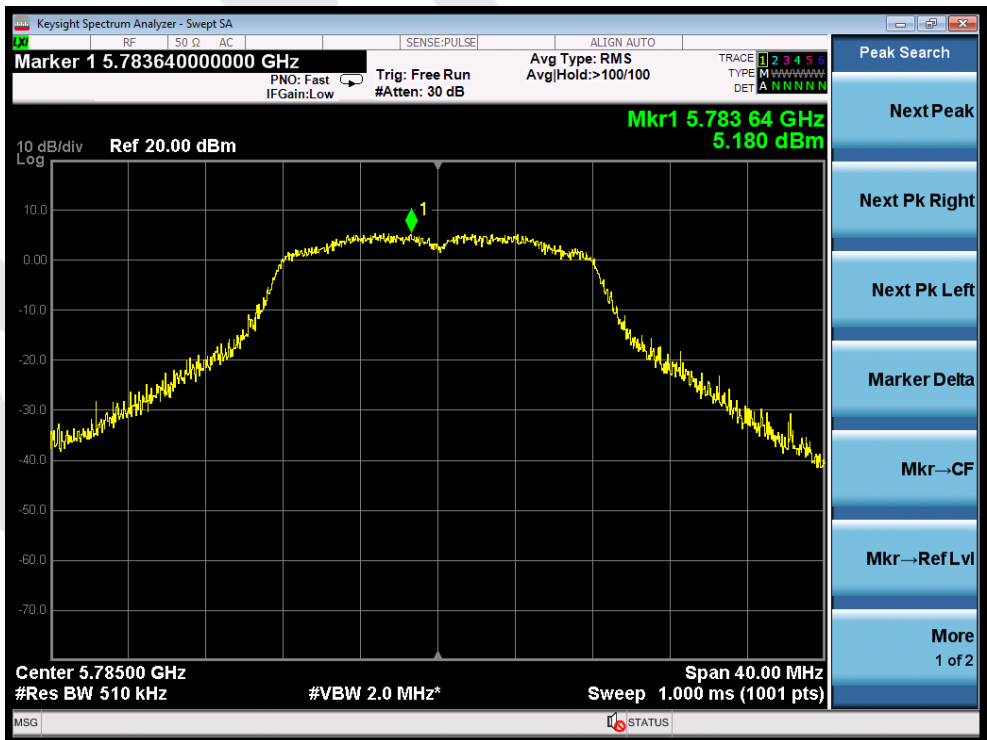

Test Mode: 802.11a---Middle

Anbotek

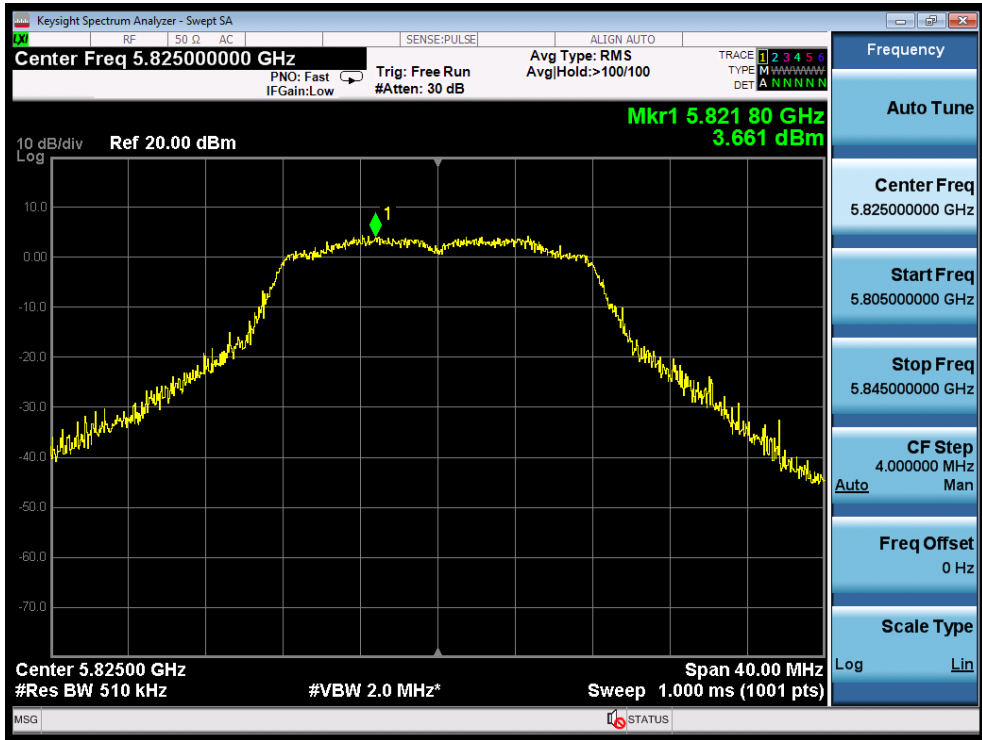

Test Mode: 802.11a---High

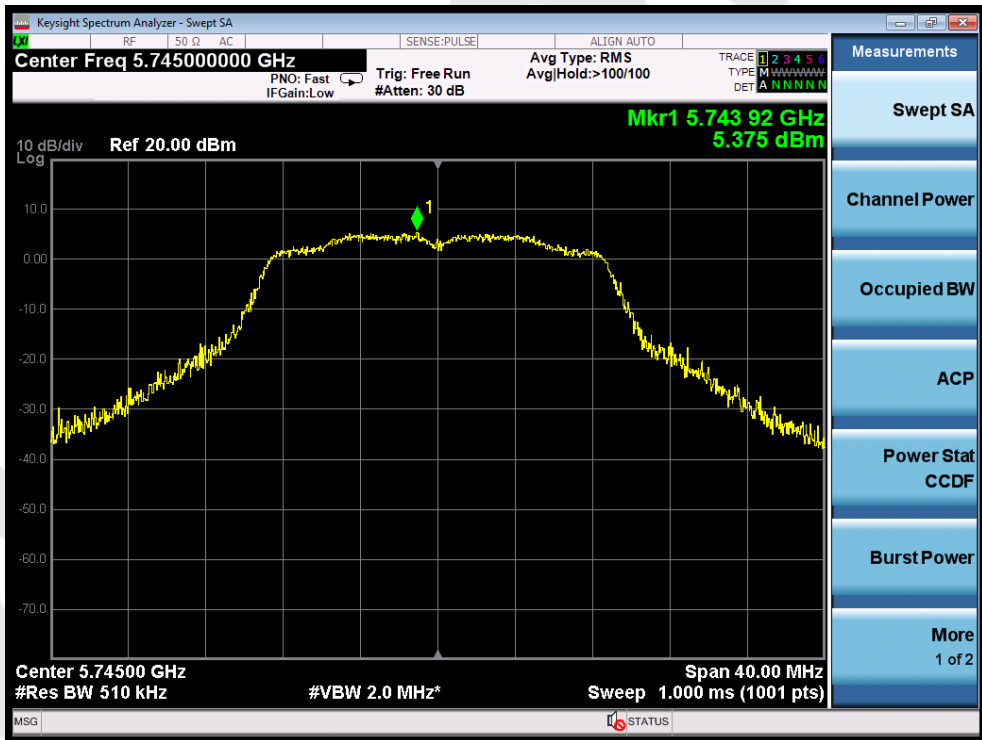

Test Mode: 802.11n20---Low

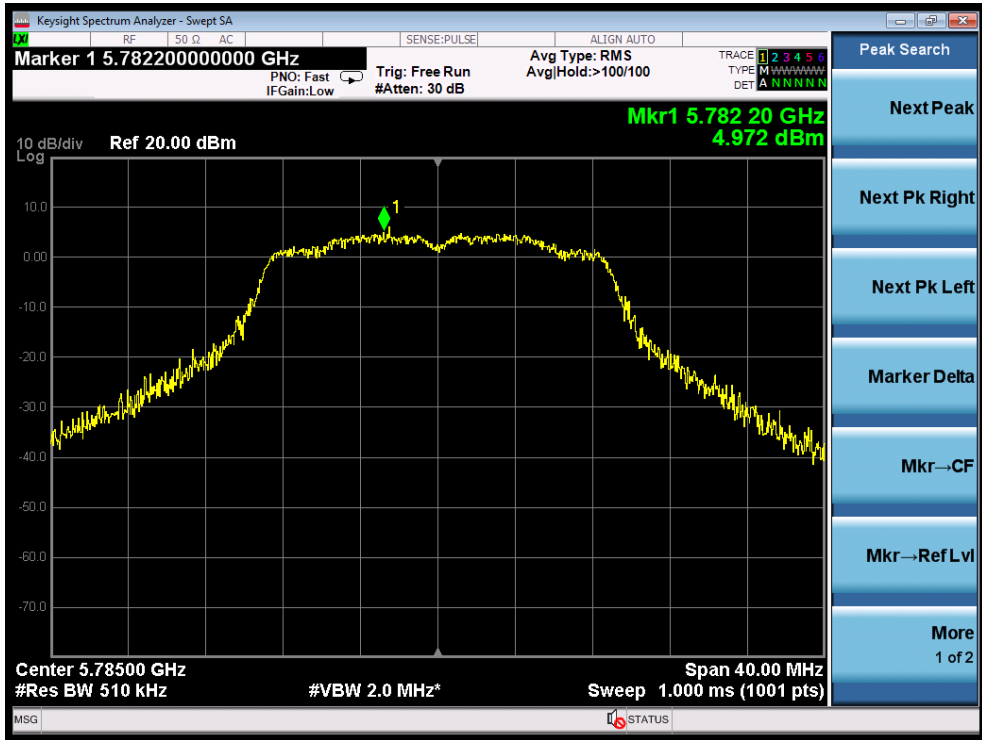

Test Mode: 802.11n20---Middle



Test Mode: 802.11n20---High

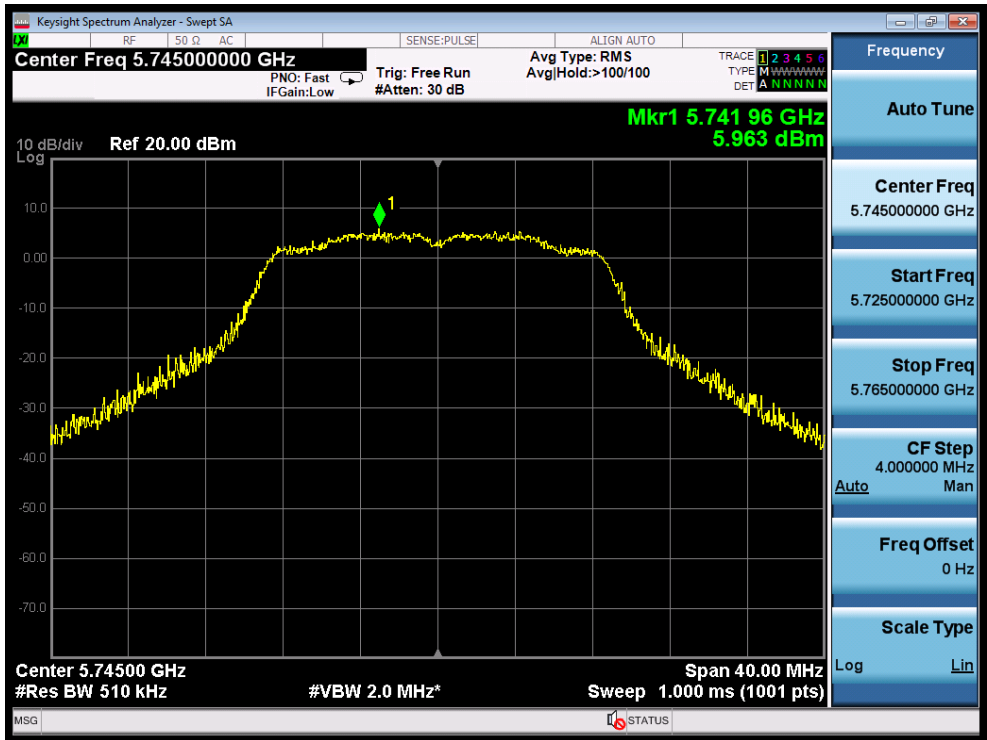

Test Mode: 802.11ac20--Low

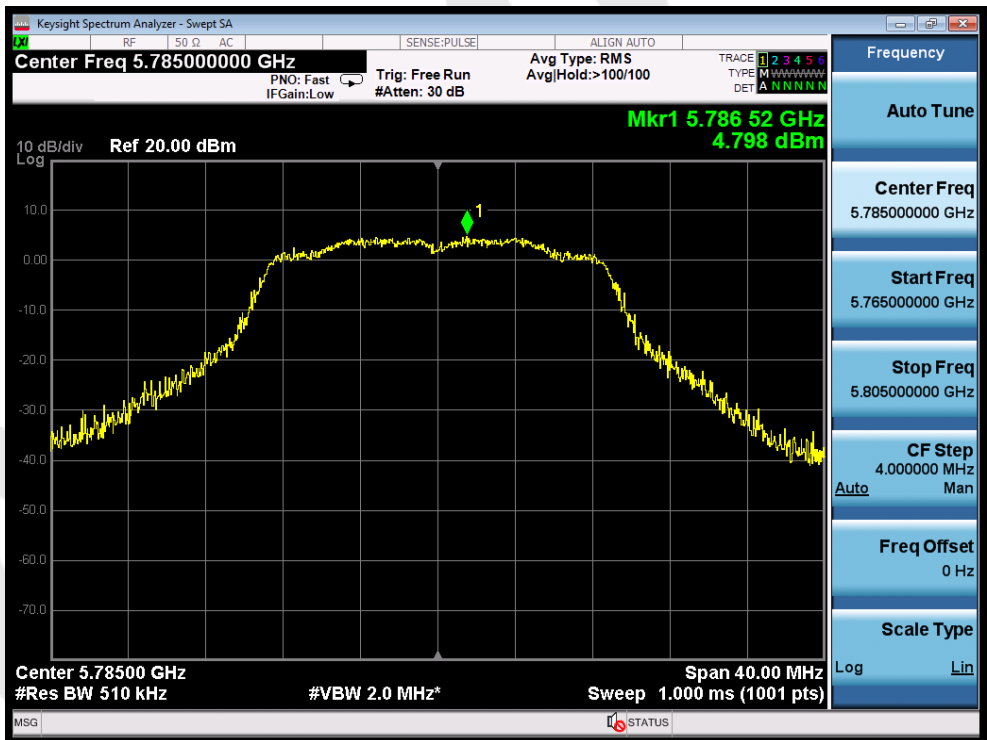

Test Mode: 802.11ac20---Middle

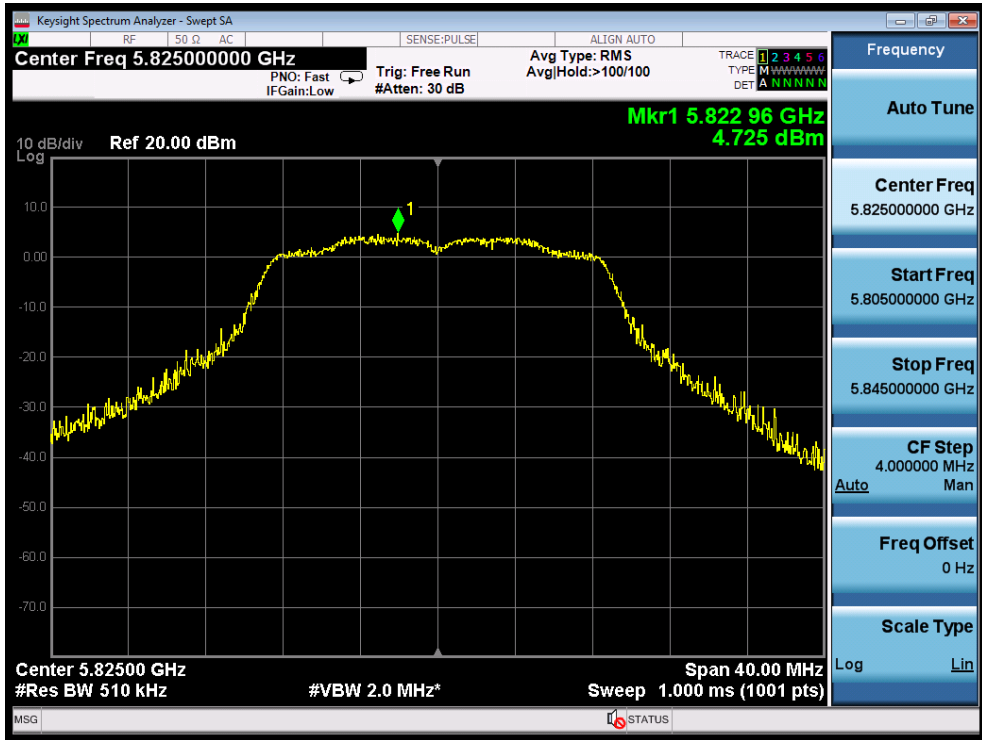

Test Mode: 802.11ac20---High

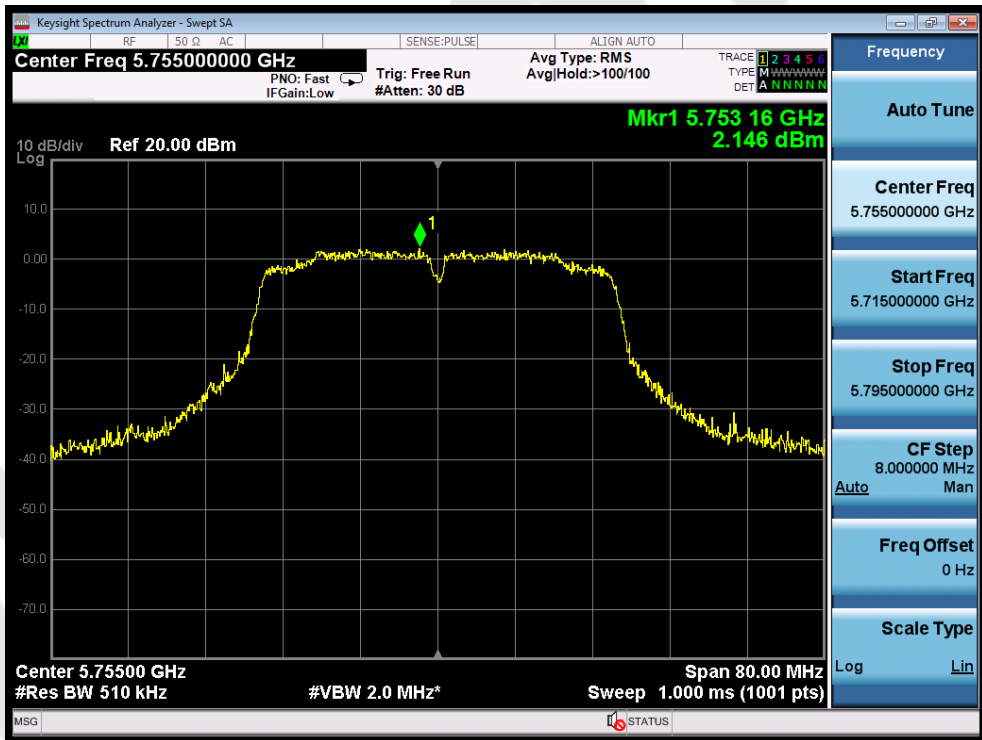

Test Mode: 802.11n40---Low

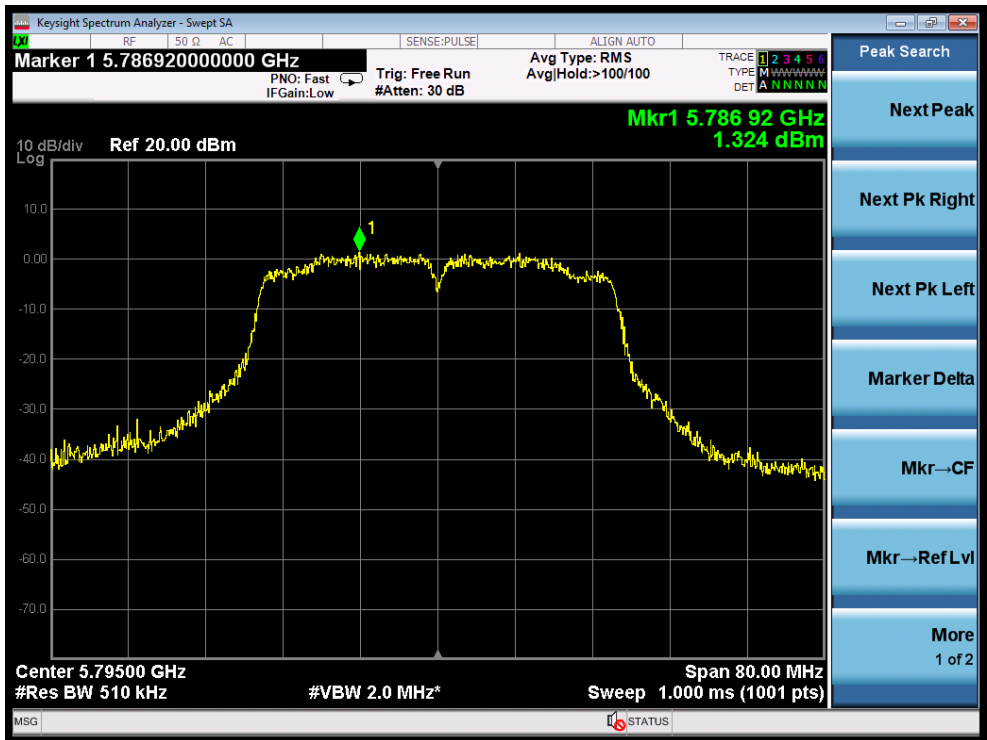

Test Mode: 802.11n40---High

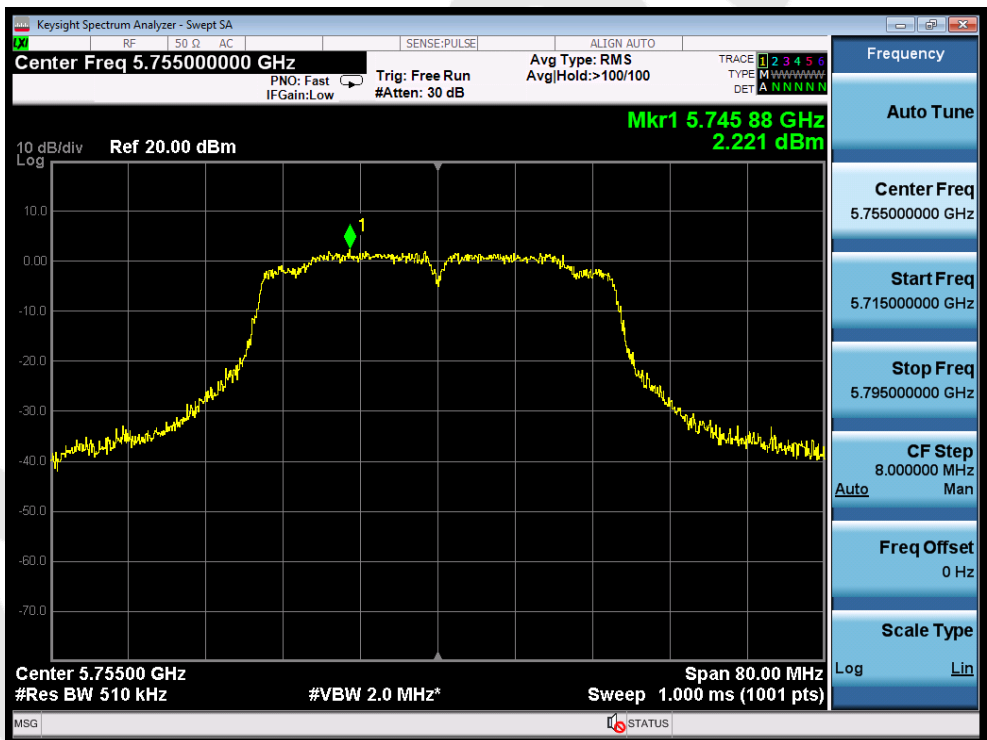

Test Mode: 802.11ac40---Low





Test Mode: 802.11ac40---High

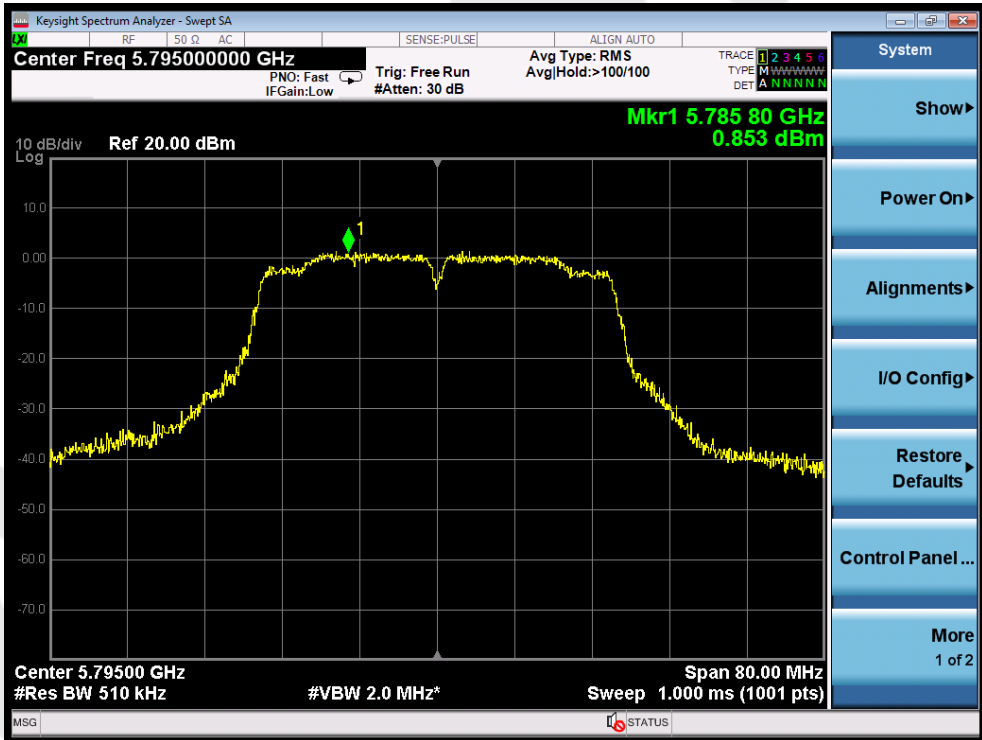

Test Mode: 802.11ac80

ANT 2

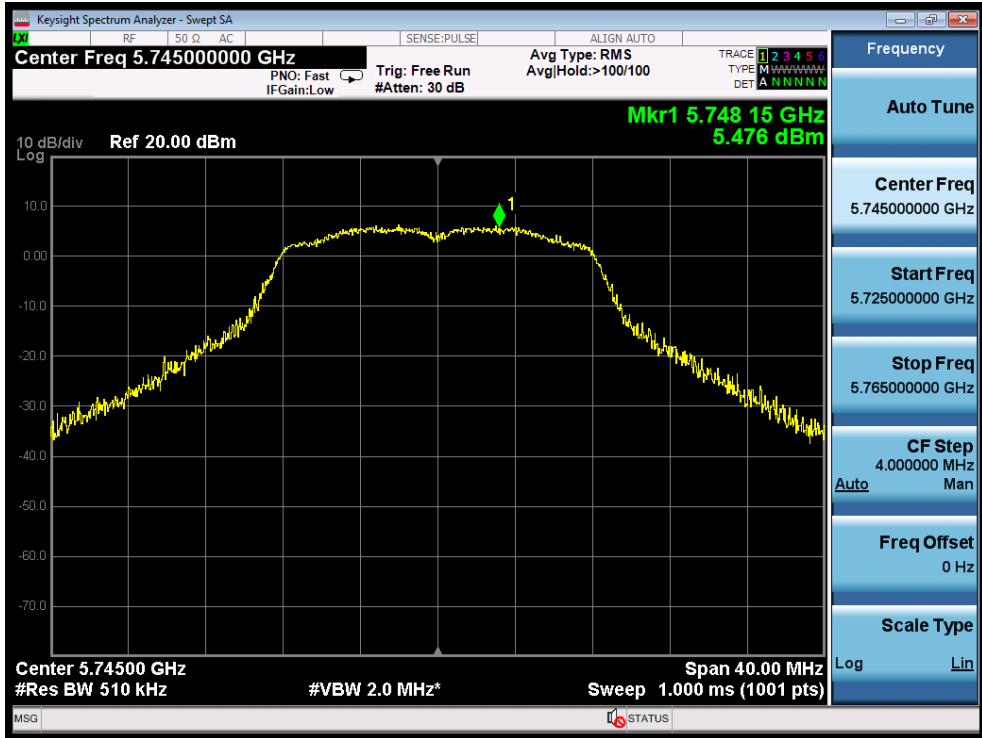

Test Mode: 802.11a--Low

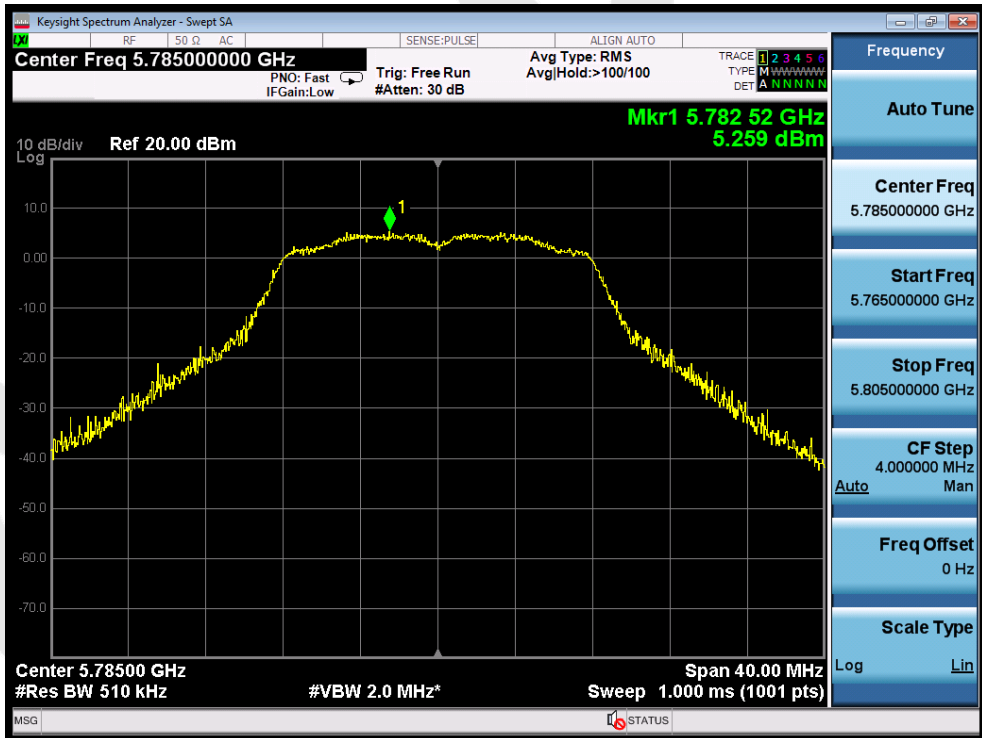

Test Mode: 802.11a---Middle