



# SPECIFICATION

Product Name: High Bay Sensor for Warehouse

Model No.: MC079D RC 3(daylight priority)

Issue Date: Mar. 13, 2020

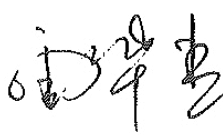
CUSTOMER APPROVED

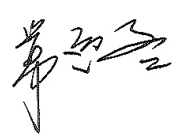
PRODUCT DIRECTOR APPROVED	SALES CHECKED	R&D CHECKED	PREPARED
			

Shenzhen Merrytek Technology Co.,Ltd

Add: 2<sup>nd</sup> and 3<sup>rd</sup> floor, NO.3 Building, 380 Xiangshan Avenue, Luotian, Yanluo, Baoan, Shenzhen, 518127,China  
Tel: +86 (0)755-2305 7253 Fax: +86 (0)755-2786 3012 Website: www.merrytek.com

## 1. Features



- 12/24V DC input, for DC systems or LED power supplies with 12/24V DC auxiliary power output
- 0-10V dimming port, 3 or 2 step dimming function
- Newly patent design sensor antenna with two detection mode: high sensitivity detection and interference immunity detection. (suitable for installation environments with many metal reflective surfaces)
- Plug-in design with IP65 water-proof design
- 15m maximum installation height, suitable for most warehouses
- Patented remote control, transmitting angle of the remote control is adjustable according to mounting height
- Dim+/Dim- to set occupancy light level
- Daylight priority function
- 5 years warranty

## 2. Parameter

<b>Input</b>	Operating Voltage Range	N/A
	DC Input Voltage	12/24V DC ±1V
	Rated Voltage	12/24V
	No-load Power	N/A
	Stand-by Power	<0.3W
	Surge Test	N/A
	Wiring	Screw terminals
<b>Output</b>	Working Mode	0-10V DC
	Type of Load	N/A
	Load Capacity	N/A
	Current of Load	N/A
	Wiring	Screw terminals
<b>Dim Interface</b>	0-10V Dimming	< 50mA (Non-constant source)
	Synchronous Control	N/A
	High Low-level	N/A
	PWM Control	N/A
<b>Sensor Parameters</b>	Operating Frequency	5.8 GHz ±75 MHz , ISM Band.
	Transmitting power	1mW Max.
	Hold time	5S/30S/1min/3min/5min/10min/20min/30min
	Stand-by DIM Level	10%(1.4-1.6V), 20%(1.9-2.1V), 30%(2.9-3.1V), 50% (4.9-5.1V)

Shenzhen Merrytek Technology Co.,Ltd

Add: 2<sup>nd</sup> and 3<sup>rd</sup> floor, NO.3 Building, 380 Xiangshan Avenue, Luotian, Yanluo, Baoan, Shenzhen, 518127, China

Tel: +86 (0)755-2305 7253

Fax: +86 (0)755-2786 3012

Website: www.merrytek.com

	Stand-by Period	0s/10S/1min/3min/5min/10min/30min/+∞
	Detection Area	25%/50%/75%/100%
	Daylight Sensor	Daylight threshold: 5lux/15Lux/30Lux/50Lux/100lux/150lux/Disable Daylight priority: ON/OFF value (5lux/15Lux/30Lux/50Lux)/150Lux 100Lux/200Lux 150Lux/300Lux
	Detecting Radius	See detection pattern
	Mounting Height	15m Max
	Detecting Angle	150°(wall mounting) 360°(ceiling mounting)
	<b>Wireless Module</b>	Operating Frequency
Transmitting power		N/A
Transmitting distance		N/A
Modulation mode		N/A
Number of coding		N/A
<b>Operating Environment</b>	Operating Temperature	-35°C...+70°C
	Storage Temperature	Temperature: -40°C...+80°C; Humidity: 10%-95% (non-condensing)
<b>Certificate Standards</b>	Safety standards	EN60669-2-1, EN60669-1
	EMC standards	EN55015, EN61000-3-2, EN61000-3-3, EN61547
	Environmental Requirement	Compliant to RoHS
	Certificate	NA
	IP Rating	IP65
	Protection Class	Class II
	Installation	External mounting,integrated mounting
	Dimension	See dimension
	Package	White paper box
	Net Weight	55g
	Lifetime	5 years warranty @Ta 230V full load
<p>Note</p> <p>1. "N/A" means not available.</p> <p>2. Detection area is effected on volume of motion object and motion speed. The detection area is tested by a 165cm height person and walking speed is 0.5m/s.</p>		

### 3.Function

#### 1) On/OFF Function (stand-by period be set to "0"s)

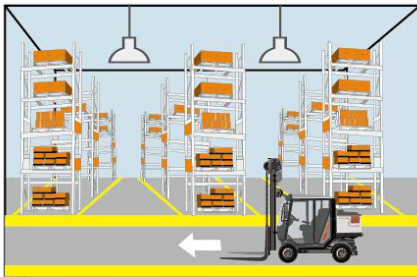

1 With sufficient ambient light, the light will not be switched on even if with motion signal.

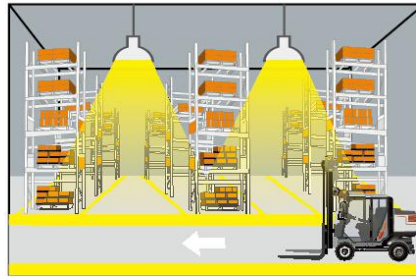

2 With insufficient ambient light, the sensor switches on the light when motion is detected.

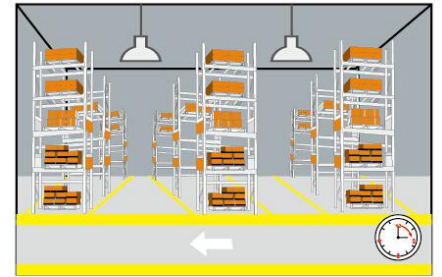

3 After elapse of hold time, the sensor switches off the light when no motion is detected.

#### 2) 2-step dimming function (stand-by period be set to "+∞")

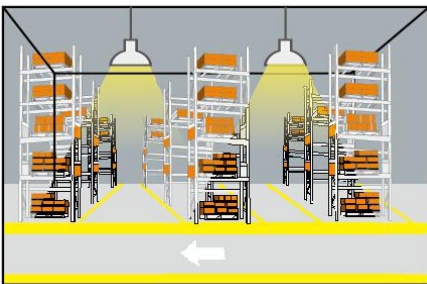

1 If there is no motion detected, the light will be remained at a low light level all the time.

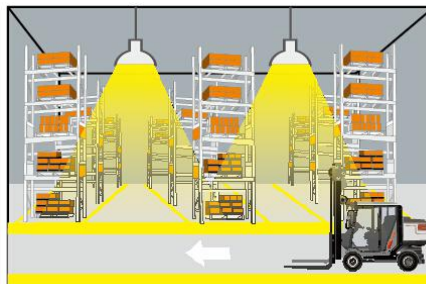

2 When motion is detected, the sensor will switch on the light to 100% brightness

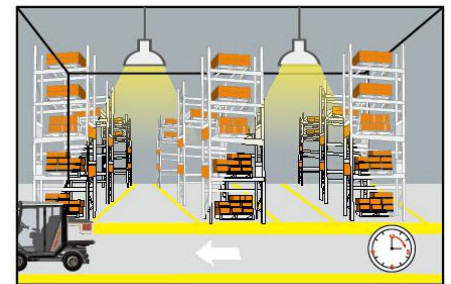

3 After elapse of hold time, the sensor dims the light at the present low light level if no motion is detected.

#### 3) 3-step dimming function (stand-by period be set to "10S/1min/3min/5min/10min/30min")

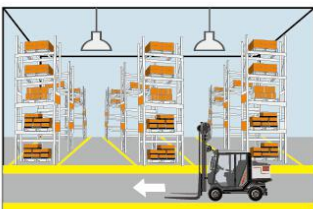

1 With sufficient ambient light, the light will not be switched on even if with motion signal.

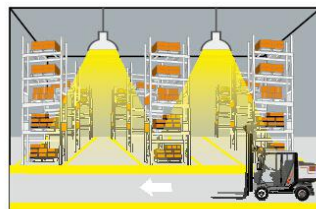

2 With insufficient ambient light, the sensor switches on the light when motion is detected.

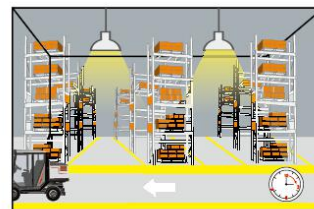

3 After elapse of hold time, the sensor dims the light at a low light level if no new motion is detected.

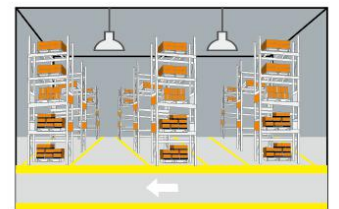

4 After elapse of standby period, the sensor switches off the light if no motion is detected in the detection zone.

4) Daylight priority (stand-by period set to  $+\infty$ )

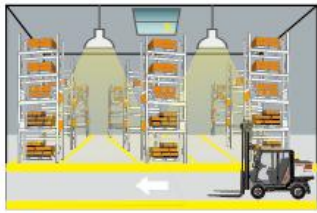

1 Lamp turns on at low light level 10% in the night.

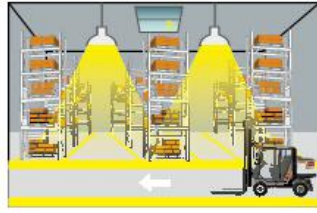

2 Motion detected, lamp automatically lights up to 100%.



3 After hold time, the lamp gradually dims to a low light level 10% if no movement detected.

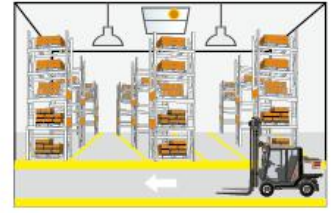

4 Lamp turns off after dawn.

4.Dimension (mm)

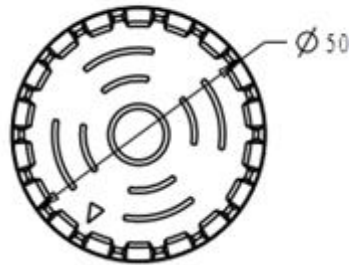
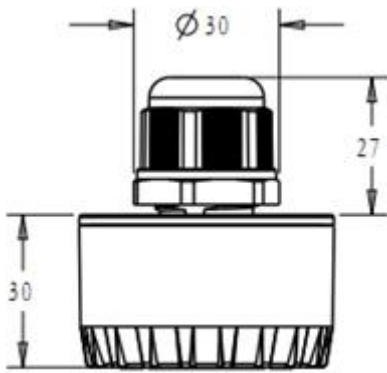

5.Wiring

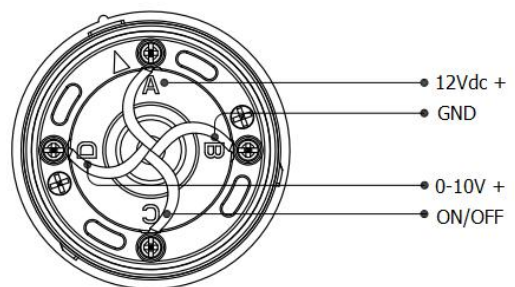
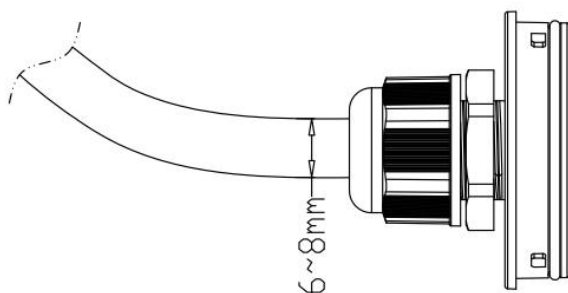

\*The sensor is designed for connect one load only. Connect more than one loads may damage the sensor.

## 6. Structure

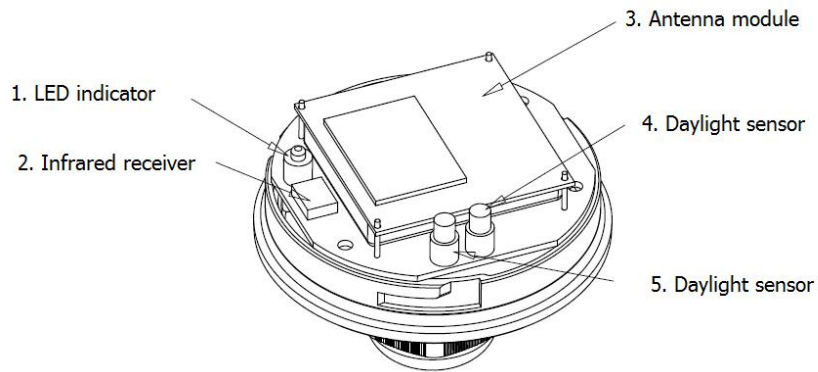

## 7. Installation

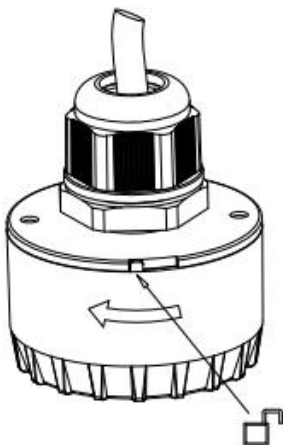
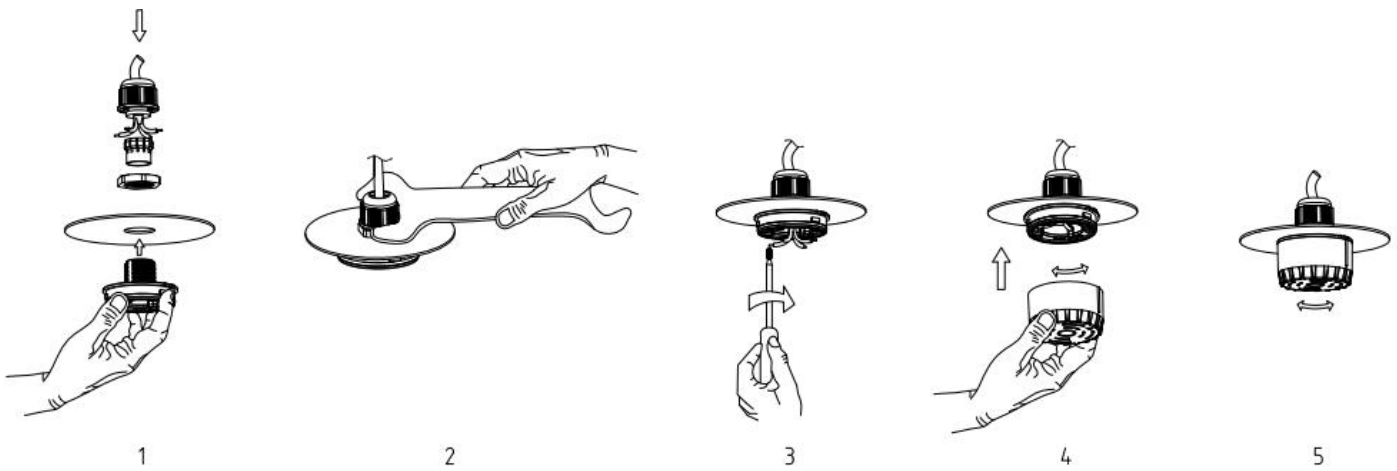

Turn left to open the cover

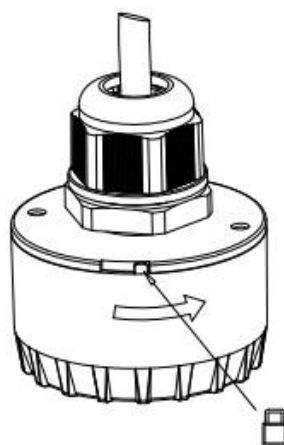

Turn right to lock the cover

## 8 .Radiation Pattern

### Ceiling mounting

Ceiling mounted height: 3m  
Sensitivity: 100%/75%/50%/25%

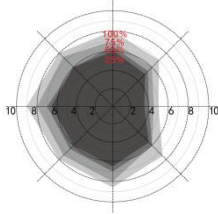

Normal moving (Speed:1m/s)

Ceiling mounted height: 12m  
Sensitivity: 100%/75%/50%/25%

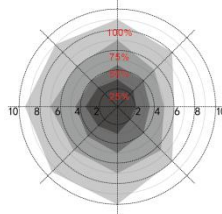

Normal moving (Speed:1m/s)

Ceiling mounted height: 15m (\*)  
Sensitivity: 100%/75%/50%

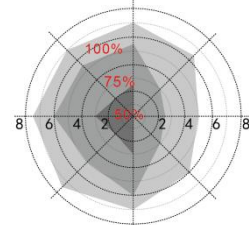

Normal moving (Speed:1m/s)

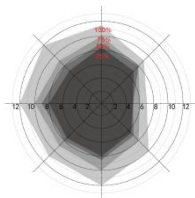

Slow moving (Speed 0.3m/s)

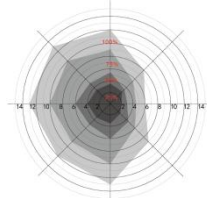

Slow moving (Speed 0.3m/s)

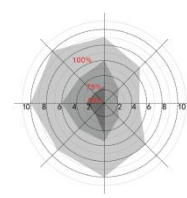

Slow moving (Speed 0.3m/s)

\*Only 100%/75%/50% detection sensitivity is workable when installed at 15m mounting height. 25% sensitivity is not able to detect motion signal.

### Wall mounting

Horizon mounted height: 2m  
Sensitivity: 100%/75%/50%/25%

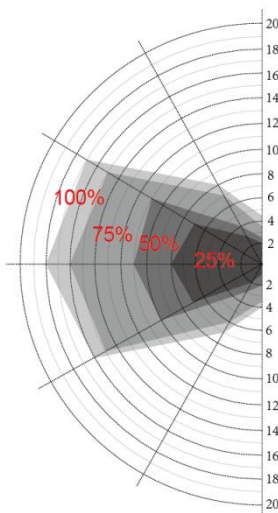

Normal moving (Speed: 1m/s)

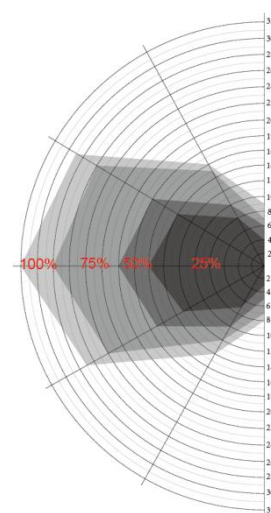

Slow moving (Speed 0.3m/s)

Shenzhen Merrytek Technology Co.,Ltd

Add: 2<sup>nd</sup> and 3<sup>rd</sup> floor, NO.3 Building, 380 Xiangshan Avenue, Luotian, Yanluo, Baoan, Shenzhen, 518127,China  
Tel: +86 (0)755-2305 7253 Fax: +86 (0)755-2786 3012 Website: www.merrytek.com

## 9 .Remote Control

Remote Control Setting	Button	Remarks																												
		Press the "ON/OFF" button, the light goes to constant on/off mode, sensor is disabled. Press "Reset" "Auto mode" button to quit from this mode and the sensor starts to work.																												
	Reset	Press "Reset" button, all parameters are same as setting of DIP switch or factory settings.																												
	Sensor motion	Press "Sensor motion" button, the light quits from the constant on/ off mode, and the sensor starts to work ( The latest setting stays in validity )																												
	DIM Test	Press "DIM Test" button, the 1-10 V dimming works to test whether the 1-10Vdc dimming ports are connected properly. After 2s, it returns to the latest setting automatically.																												
	Dvverride DH	Long press 3s, Daylight priority mode will be switched to daylight threshold mode, lux value will go back to previous one.																												
	DIM+ DIM-	Short press "DIM+/DIM-" button to Set the output lumen level, each press will will $\pm 2\%$ light level																												
	DH Mode	Long press >3s, sensor will be switched to daylight priority mode; if preset daylight value is Disable, press DH Mode can not start daylight priority mode.																												
	Q1 Q2 Q3	<table border="1"> <thead> <tr> <th>Scene Options</th> <th>Detection Area</th> <th>Hold Time</th> <th>Stand-by period</th> <th>Stand-by dim level</th> <th>Daylight Sensor</th> <th>Induction model</th> </tr> </thead> <tbody> <tr> <td>QS1</td> <td>100%</td> <td>5min</td> <td>10min</td> <td>10%</td> <td>30Lux</td> <td>Hs</td> </tr> <tr> <td>QS2</td> <td>100%</td> <td>10min</td> <td>30min</td> <td>10%</td> <td>Disable</td> <td>Hs</td> </tr> <tr> <td>QS3</td> <td>100%</td> <td>20min</td> <td>30min</td> <td>10%</td> <td>Disable</td> <td>Hs</td> </tr> </tbody> </table>	Scene Options	Detection Area	Hold Time	Stand-by period	Stand-by dim level	Daylight Sensor	Induction model	QS1	100%	5min	10min	10%	30Lux	Hs	QS2	100%	10min	30min	10%	Disable	Hs	QS3	100%	20min	30min	10%	Disable	Hs
	Scene Options	Detection Area	Hold Time	Stand-by period	Stand-by dim level	Daylight Sensor	Induction model																							
	QS1	100%	5min	10min	10%	30Lux	Hs																							
	QS2	100%	10min	30min	10%	Disable	Hs																							
	QS3	100%	20min	30min	10%	Disable	Hs																							
	TEST 2S	Press the "TEST 2S" button can enter the test mode any time. At the mode, the sensor parameters as below: Detection Area is 100%, Hold Time is 5s, Stand-by Dim Level is 10%, Stand-by Period is 0s, daylight sensor disable. This function only for testing. Quit the mode by pressing "RESET" or any other function buttons.																												
	HS LS	Press "HS" button to set the detection area to be high sensitive. Press "LS" button to set the detection area to be low sensitive. The adjustment bases on the "Detection Area" parameter you set.																												
		Daylight Sensor Set up daylight threshold: 5Lux/15Lux/30Lux/50Lux/100Lux/150Lux/ Disable.																												
	Stand-by period Set up stand-by time: 0S/10S/1min/3min/5min/10min/30min/+ $\infty$																													
	Hold time Set up hold time: 5S/30S/1min/3min/5min/10min/20min/30min																													
	Stand-by dim level Set up stand-by dim level: 10%/20%/30%/50%																													
	Detection Area Set up detection area: 25%/50%/75%/100%																													
	Remote Distance Toggle button can set the remote distance of remote control and sensor.																													

## 10. Initialization

1) On/Off function /3-step dimming function:

After power on, the sensor automatically turns on light at 100% brightness. After 10sec, it turns off the light. During the initialization, the sensor is not able to detect movement.

Shenzhen Merrytek Technology Co.,Ltd

Add: 2<sup>nd</sup> and 3<sup>rd</sup> floor, NO.3 Building, 380 Xiangshan Avenue, Luotian, Yanluo, Baoan, Shenzhen, 518127, China

Tel: +86 (0)755-2305 7253

Fax: +86 (0)755-2786 3012

Website: www.merrytek.com



2) 2-step dimming function:

After power on, the sensor automatically turns on light at 100% brightness. After 10sec, it dims the light to a low light level (set by stand-by dim level). During the initialization, the sensor is not able to detect movement.

## 11. Factory Setting

Detection area: 100%, Hold Time: 5S, Stand-by Period: 0s, Stand-by dim level: 10%, Daylight Sensor: Disable

## 12. Application Notice

- 1) The sensor should be installed by a professional electrician. Please turn off the power before installing, wiring, changing the setting of the DIP switch.
- 2) The sensor which installed in the plastic and glass lampshade will reduce the sensitivity. For every 3mm increase in thickness, the sensitivity will be reduced by 20%.
- 3) The dimming performance could be different from different 0-10v drivers.
- 4) The light sensitivity threshold is in a sunny environment, no shadow and ambient light diffuse reflection. Ambient lux level could be different in different environment, weather, climate, time-of-day and season.
- 5) The parameters of the sensor may need to be reconfigured in different installation environments. Please refer to the following instructions or contact the manufacturer.
- 6) This sensor is for indoor use only. It will affect the waterproof effect for outdoor use. Wind, rain, and moving objects around will cause false triggering.
- 7) The distance between any inductive sensors should be greater than 3m.
- 8) Do not place the sensor close to high-density objects such as metal, glass, concrete walls, etc, false triggering could happen. When the sensor is installed in a metal lamp, metal reflective surface, or a narrow enclosed environment, the microwave will be reflected repeatedly and cause false triggering. Please reduce the sensitivity or contact the manufacturer for technical support.
- 9) Please ensure that there are no moving signals around the sensor, such as fan, DC motor, sewer pipe, air outlet, etc., the sensor may generate false trigger.
- 10) You are advised to test 5 samples before mass application of sensor in a new lighting project.
- 11) Due to continuous improvement, the contents of this instruction could be changed without prior notice

#### FCC Warning

This device complies with part 15 of the FCC rules. Operation is subject to the following two conditions: (1) this device may not cause harmful interference, and (2) this device must accept any interference received, including interference that may cause undesired operation.

Changes or modifications not expressly approved by the party responsible for compliance could void the user's authority to operate the equipment.

NOTE: This equipment has been tested and found to comply with the limits for a Class B digital device, pursuant to part 15 of the FCC Rules. These limits are designed to provide reasonable protection against harmful interference in a residential installation. This equipment generates uses and can radiate radio frequency energy and, if not installed and used in accordance with the instructions, may cause harmful interference to radio communications. However, there is no guarantee that interference will not occur in a particular installation. If this equipment does cause harmful interference to radio or television reception, which can be determined by turning the equipment off and on, the user is encouraged to try to correct the interference by one or more of the following measures:

- Reorient or relocate the receiving antenna.
- Increase the separation between the equipment and receiver.
- Connect the equipment into an outlet on a circuit different from that to which the receiver is connected.
- Consult the dealer or an experienced radio/TV technician for help.

#### Radiation Exposure Statement

This equipment complies with FCC radiation exposure limits set forth for an uncontrolled environment. This equipment should be installed and operated with minimum distance 20cm between the radiator and your body.