

User manual

X5

Content

1. Specifications	3
2. Overview (Hardware)	4
2.1 Tray A	5
2.2 Tray B	6
2.3 Tray C	7
2.4 Mechanism	8
3. Using Your MAD Gaze Correctly	11
3.1 Using with Eyeglasses	11
3.2 Using Headbands	14
4. General Hardware Operation	16
4.1 General Hardware Operation	16
4.2 Operation – Touch Panel	17
5. Built-in Battery Precautions and Charging	20
6. Image Regulation	21
7. Sleep Mode	21
8. Keyboard Operation	22
8.1 By X5 In-built Keyboard	22
8.2 By MAD Gaze Connector – Remote Control	23
9. Home Screen	24

10. Control Centre	26
10.1 Notification	28
11. Basic Settings	29
11.1 Wi-Fi Connection	29
11.2 Location Services	30
11.3 Password Settings	32
11.4 Sound and Display	33
11.5 Date and Time	34
11.6 Restore Factory Defaults	35
12. Pre-Installed Applications of MAD Gaze X5	38
13. MAD Store	39
14. MAD Gaze Connector	40
15. Data Transmission	41
16. Warranty	42
17. Limited Warranty	43
18. Cautions	44
19. FCC statement	49
20. Frequently Asked Questions	49

1. Specifications

Operation System: Android 6.0

CPU: 1.3 GHz Quad-Core

RAM: 2GB

Capacity: 32 GB

Sensors: The 9-axis inertial motion sensor include: 3-axis gyroscope, 3-axis accelerometer, 3-axis magnetometer

Display: 800 x 480(WVGA), see-through display

Audio: 3.5mm Stereo Audio, Microphone, Speaker

Camera: 8M pixels

Video playback; 1080P

Wi-Fi: 802.11 b/g/n

Position: GPS

Battery: 600mAh

Connection: Micro USB USB2.0

Control: Voice Recognition, Multi-touch Panel, Gesture Control, Light Sensor, Key Buttons, Connector App

Language: English, Simplified Chinese, Traditional Chinese

2. Overview (Hardware)

The packaging box of MAD Gaze X5 mainly consists of 3 parts, including

Tray A (p.5)

Tray B (p.6)

Tray C (p.7)

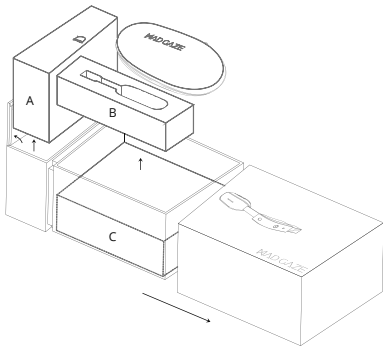

2.2 Tray B

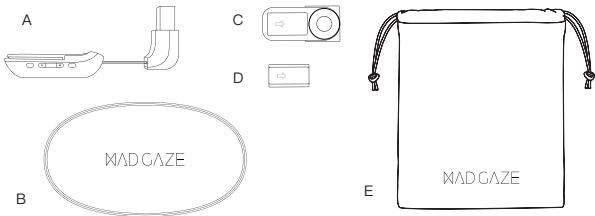

A MAD Gaze X5

B Glasses Case

C Glasses Clip (suitable for thick arm glasses)

D Glasses Clip (suitable for thin arm glasses)

E Headband and Glasses Bag

2.3 Tray C

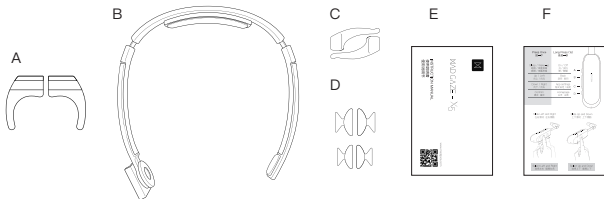

- A Slip-resistant Ear Grip for Headband
- B Headband
- C Slip-resistant Ear Grip
- D Nosepad
- E MAD Gaze X5 Instructions Manual
- F Quick Start Guide (4 sheets)

2.4 Mechanism

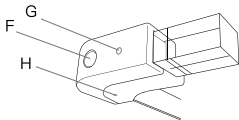
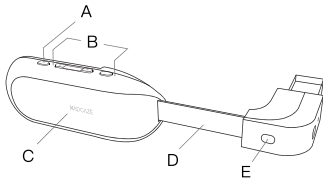

- A Power Button
- B Physical Buttons
- C Touch Panel
- D Adjustable Arm
- E Light Sensor & Proximity Detection
- F Front Camera

- G Camera Indicator
- H Microphone

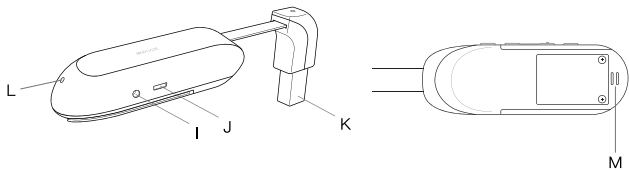

- I 3.5mm Earphone Jack
- J Micro USB Port
- K Transmissive Display
- L Power Indicator
- M Speaker

Best Sensing Area of the Panel

Please operate within the ambit of the Panel as shown. The edge of the device may have weaker sensitivity.

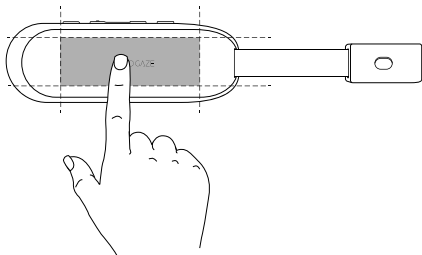

The best sensing area is shown in grey.

3. Using Your MAD Gaze Correctly

3.1 Using with Eyeglasses

MAD Gaze X5 can be equipped with your prescription glasses or glasses we provided

- The Glasses Clip is used to fix the position with your glasses.
- Please install the Glasses Clip on your glasses according to following figure.

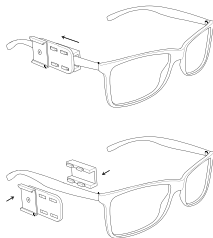
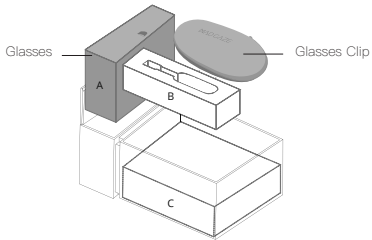

- Ensure the Glasses Clip is putting near eyeglasses temple properly and push clip forward to lock and fix the position.
- Tilt the Glasses Clip to adjust the angle of view.
- To utilize the user experience, we also provide Nosepad and Slip-resistant Ear Grip.

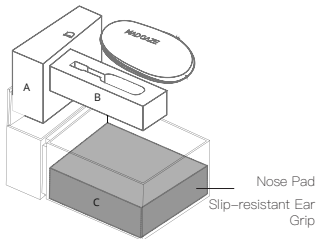
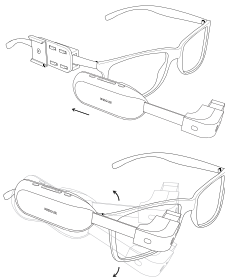

- Athletic Headband can provide better stability under strenuous movement with connecting the eyeglasses temples.
- Connect two ends of Athletic Headband to eyeglasses temples.
- Adjust the length of Athletic Headband to fix the eyeglasses position.

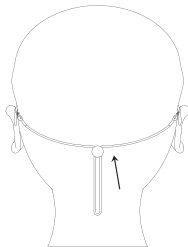
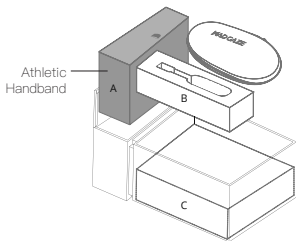

After putting on Athletic Headband (Back)

3.2 Using Headbands

MAD Gaze X5 can be equipped with your eyeglasses and compatible to various types of glasses.

- Install the Slip-resistant Ear Grip into Headband to fix the headband position.
- Turn the headband stabilizer perpendicular to the headband.

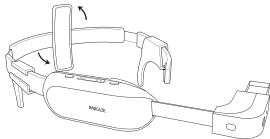
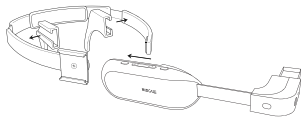
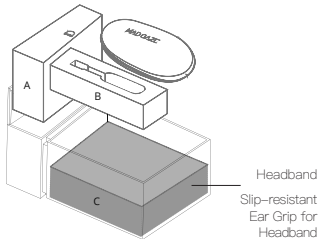

If you have equipped the Ear Grips and Headband properly, the Ear Grips and Headband stabilizer should be aligned as shown in the following figure. The screen should now align with your eyes at the same level.

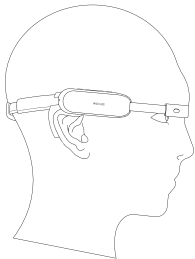

Wearing Headband (Sideview)

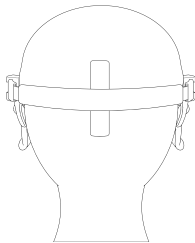

Wearing Headband (Backview)

4. General Hardware Operation

4.1 General Hardware Operation

The physical buttons for MAD Gaze X5 smartglass is located at the upper edge of the body. There are two different controlling commands – “tap” and “long press for 1 second”.

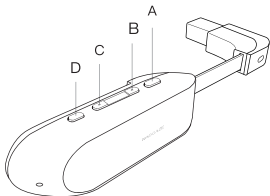

	Tap	Long Press (1s)
A	Enter	Home
B	Right/ Down	App Settings
C	Left/Up	Back
D	Sleep/ Awake	Power On/ Off

4.2 Operation – Touch Panel

Multi-touch Panel can sense the following two sliding forms of one finger.

- Tap & Swipe Forward/Backward
- Tap & Swipe Up/Down

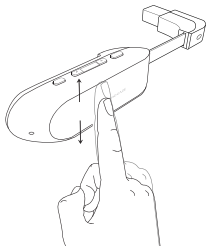
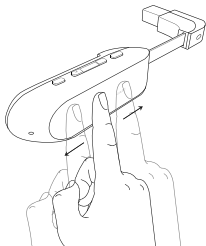

Multi-touch Panel can sense the following three forms of contact of one finger.

- Tap once with one finger to confirm or enter

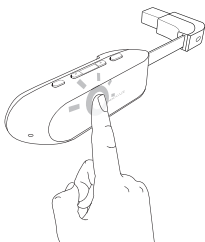

- Tap twice (on any page) with one finger to back

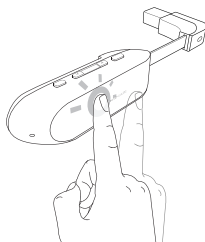

- Long press (on any page) with one finger to home

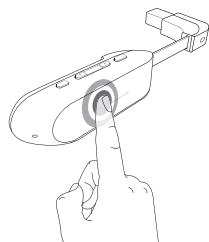

Multi-touch Panel can sense the following three forms of contact of two fingers.

- Tap twice with two fingers (when an app runs) to enter settings
- Long press (on any page) with two fingers to control centre

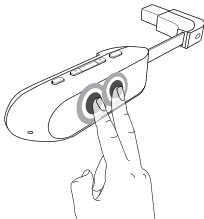
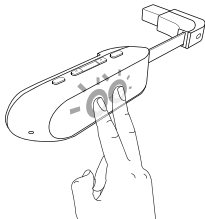

5. Built-in Battery Precautions and Charging

- This product is equipped with a built-in battery. Users should not replace it by themselves. Avoid charging in damp or overheat environment. Unauthorized replacement or attempt in forcing the product to open will void the product warranty and might lead to safety hazards. The device contains no user-serviceable parts.
- After unboxing MAD Gaze X5 smartglass, charge for at least 4 hours before use. Connect the Micro USB cable that comes with X5 to the Micro USB port on the device body; connect the other end of the Micro USB cable to the charger USB port. When power indicator is on, the smartglass is charging. The smartglass can be charged either when its power is on or off.
- Contact our Customer Services Department at support@madgaze.com for repairing services if necessary.

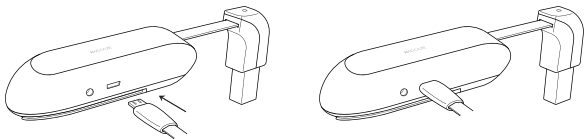

6. Image Regulation

The Adjustable Arm is designed for a better user experience. To maintain the HUD screen at eye level, you may pull the Arm closer in a zigzag way. The Arm can be bent to left or right for not more than 40 degrees.

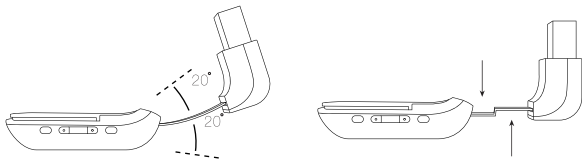

7. Sleep Mode

Sleep Mode can save battery, as well as prevent unknown conditions triggered by inadvertently touching the panel. MAD Gaze X5 will enter sleep mode under the following conditions:

- No operation within certain amount of time (the default idling limit is 60 seconds, it can be changed in the "Settings")
- Short press the power button; to wake up MAD Gaze, short press the power button again.

8. Keyboard Operation

8.1 By X5 In-built Keyboard

- Swipe up and down on the touch panel to select keyboard (Alphabets, Capital Alphabets, Numerics, Symbols and Control Pad), then swipe left and right on the touch panel to input content (e.g. 8). Select OK in the Control Pad to finish input.

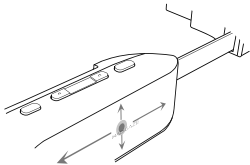

Select the keyboard type



Select and press the input



Select and press OK

- You may also use buttons to control keyboard operations (Details please refer to 4. General Hardware Operation)

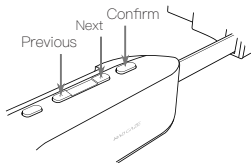

8.2 By MAD Gaze Connector – Remote Control

- To operate "MAD Gaze Connector" using mobile phone keyboard (Please refer to www.madgaze.com/support)

9. Home Screen

All apps are categorized according to their function. Apps in each category are sorted according to the alphabetical order of their names.

To select App:

- Single Finger Operation – Long press, to enter “Home” from any interface.
- Swipe up/down on the touch panel to select App Category (e.g. Recent Used), then swipe left/right on the touch panel to select app (e.g. Navigation). Tap to enter the app.
- You may perform the same operation by buttons. (Please refer to 4. General Hardware Operation)

Go To Home

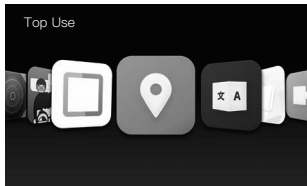
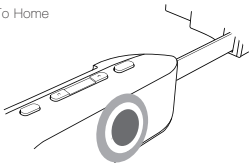

Control with Touch Panel

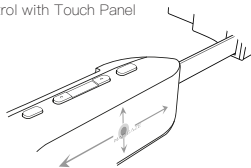

Control with physical button

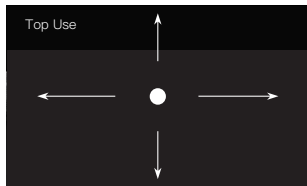
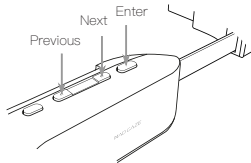

10. Control Centre

Control Centre provides shortcut for accessing basic functions, such as turning on/off Wi- Fi, Location services, or MAD Gaze Connector, etc. Notifications, application updates, media volume control, display brightness and font size adjustments are also available at the Control Centre.

- Long press on the touch panel by two fingers to enter the Control Centre from any interface.
- Swipe up/down on the touch panel, tap and select function.
- Physical buttons are also available for control and operation.

Go to Control Centre

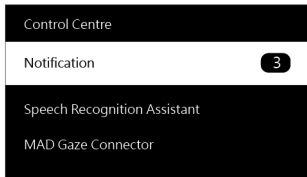
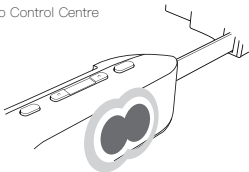

Control with touch panel

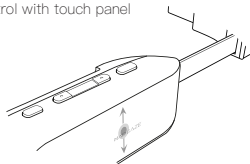

Control with physical button

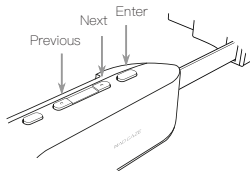

Setting	
Location Services	ON
Security	↓
Control Centre	
Font Size	↑ Medium
Media Volume	32%
Brightness	↓ 55%

10.1 Notification

Notifications such as news, alarm clock, application updates, etc. are available in Control Centre.

- Swipe with one finger from back to front to clear a notification.

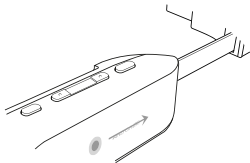

Notifications

🕒 Alarm 3:00 after the reminder

📍 You have arrived your destination

Delete all notifications

Notifications



📍 You have arrived your destination

Delete all notifications

11. Basic Settings

11.1 Wi-Fi Connection

Connect MAD Gaze X5 with Wi-Fi

Go to “Settings”-> “Wi-Fi”, turn on or off Wi-Fi. You may also set up in the Control Centre. The screen will list all previously connected network, choose a network and connect. Use keyboard to enter password if required. (Please refer to 8. Keyboard Operation)

If you wish to join a new Wi-Fi network which has never been connected before, pick “Scan Wi-Fi” at the bottom of the list.

- To join a closed Wi-Fi network, please use the mobile app, MAD Gaze Connector to do so. You will need the network name, security type and password.
- To forget a network, tap a previously joined network, select “Forget this network” in the network operation interface, connection record and relevant data will be removed.

Connect MAD Gaze Connector to Wi-Fi

You may also use MAD Gaze Connector to connect Wi-Fi

(Please go to www.madgaze.com/support for more information using the MAD Gaze Connector.)



Settings	
Wi-Fi	mad_AC
Location Services	ON

11.2 Location Services

Location Services allow location based apps, such as “Navigation” to gather and use data that indicates your location. Your approximate location is determined by available information from your mobile data, local Wi-Fi networks (if you have Wi-Fi turned on) and GPS (subject to certain areas).

- Go to “Settings” -> “Location Services”, either turn on or off.

Mode: You may switch to different levels of positioning accuracy, the system sets high accuracy (GPS and network) mode by default.

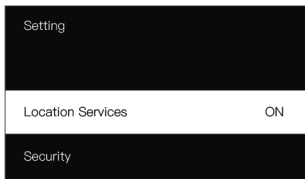

11.3 Password Settings

Password can be set to unlock and re-activate MAD Gaze X5 for a higher security level. It must be entered each time you turn on or wake up your device.

- To set a password, go to “Settings”> “Security”> “Screen Lock”, or “Control Centre”> “Settings”> “Security”> “Screen Lock”, then set password for screen locking according to instructions, using the touch panel.
- To change password, go to “Screen Lock”> “Change Password”
- Note: Physical buttons cannot be used for setting password.

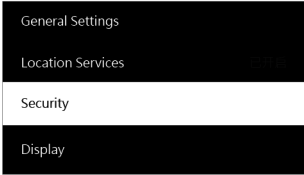

General Settings

Location Services

Security

Display



Security

Screen Lock

11.4 Sound and Display

To maintain the user experience level, the volume and screen brightness can be adjusted to an optimal level.

- To adjust the brightness, go to “Control Centre”> “Settings”> “Brightness”, or go to “Home” and look for “Settings”> “Brightness”, then swipe left and right on the touch panel to adjust, or adjust the brightness by physical buttons.
- To adjust the volume, go to “Control Centre”> “Settings”> “Volume”, or go to “Home” and look for “Settings”> “Volume”, then swipe left and right on the touch panel to adjust, or adjust the volume by physical buttons.

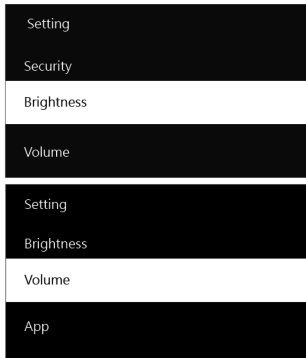

11.5 Date and Time

The system automatically determines the date and time when the device is connected to a network. To change the date and time, go to “Control Centre” > “Settings” > “Date and Time”, or go to “Home” and look for “Settings” > “Date and Time”, then turn off “Set Automatically”.

- Swipe left and right on the touch panel to switch from items (e.g. Month)
- Swipe up and down on the touch panel to adjust the value (e.g. 9)

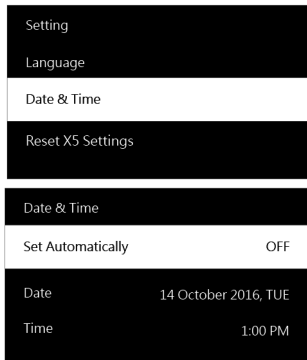

11.6 Restore Factory Defaults

Please note that all data and information will be erased. Reset Action is irreversible and unrecoverable.

- To reset the device, go to "Control Centre" > "Settings" > "Restore factory defaults", follow the instructions to complete resetting procedures.

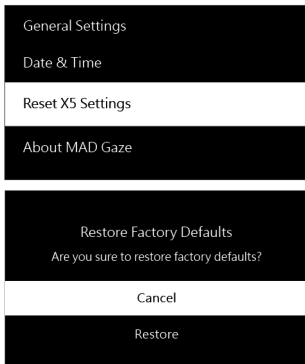

12. Pre-Installed Applications of MAD Gaze X5

- MAD Gaze X5 contains different sorts of original apps including voice assistant, which provides instant news, weather, and all kinds of information; and GPS navigation which will be your helpful partner; and also an effective translator that can analysis image and translate the text contained.
- For details and tutorial, please refer to www.madgaze.com/cases



13. MAD Store

Go to MAD Store and discover more applications.

- Login to MAD Store at <http://store.madgaze.com> with mobile phone or computer
- Login with your MAD ID
- Click on any application
- Select the device to install in the pop up screen
- Downloaded application will automatically install onto the smartglass after connecting to Wi-Fi
- Apps can be accessed via Home after installation (Please refer to: 9. Home Description and Operation)



14. MAD Gaze Connector

MAD Gaze Connector is required to finish the beginner's tutorial. If it is not downloaded yet, please go to Play Store or App Store and search for "MAD Gaze Connector"

- To enter MAD Gaze Connector via MAD Gaze X5, please go to "Home" > "MAD Gaze Connector" or "Control Centre" > "MAD Gaze Connector"

Download MAD Gaze Connector:



Enter MAD Gaze Connector with X5:



MAD Gaze Connector has 4 major functions to help with easier smartglass operation, including:

- MAD ID Configuration: Configure with MAD ID
- Wi-Fi Connection: Connect to wireless network (Wi-Fi)
- Account and Device: Check up information of MAD ID and paired smartglass (including maintenance period)

For operation guide and details of MAD Gaze Connector, please refer to: www.madgaze.com/support



16. Warranty

- We will provide an all-round Three Guarantees Service for your product according to “The Warranty Regulations of Three Guarantees” enacted by relevant authorities in the People’s Republic of China.
- Warranty period will be counted from the day the product is activated, for one year. The valid warranty period can be checked up on MAD Gaze Connector or “My Device” in MAD Store.
- Within 7 days after the product is activated, if the product is malfunctioned, you can either return or replace your product, or you may wish to have it repaired by an authorized maintenance service provider.
- From the 8th to 30th day after the product is activated, if the product is malfunctioned, you can either replace your product, or you may have it repaired by an authorized maintenance service provider.
- Within 1 year after the product is activated, if the product is malfunctioned, you can have it repaired by an authorized maintenance service provider.
- From the 30th day to 1 year after the product is activated if the product is malfunctioned, and is still malfunctioning after repairing for twice, you can exchange for another device with same model number and specification for free, by providing the maintenance records.
- MAD Gaze Warranty Centre located in mainland China, our company will not be liable for any costs incurred as a result of the warranty procedures (including, but not limited to: freight, taxes, customs fees, and all other other possible fees), all buyers must bear all relevant

- expenses.

*For details of activation steps, please refer to the tutorial in MAD Gaze Connector.

17. Limited Warranty

Your warranty services are valid under normal usage/application only, the following conditions are excluded from the Three Guarantees and there will be reasonable charge for the warranty service:

- The free maintenance period of the product has expired.
- Mechanical failure due to application of fittings not recognized by our company.
- Damage caused by disassembling the product by repairer who is unauthorized by our company.
- Damage caused by failing to operate the product according to the manual, or incorrect/improper handling of the product.
- Malfunction caused by improper use, maintenance or storage.
- Products natural wear and tear (including, but not limited to outer case, display, attachments).
- Damage caused by force majeure.
- All the losses and damage caused by environmental factors, such as rough handling, Temperature, and other factors which beyond our company's control.

- If user cracked the Android system, or illegally obtained the root privileges, causing malfunction of this product, we reserve the right to refuse providing warranty services.

18. Cautions

- Use only the supplied USB cable. Using other USB cable may cause overheating, fire, explosion, failure or leakage.
- Do not detach the power cable by coercive pulling.
- Do not allow metal objects, flammable materials or other objects insert or fall into the power connector, power port or speaker it may cause short circuit and trigger fire or electric shock.
- Some users might experience skin irritation or skin allergies with prolonged use of this product. If you notice any symptoms, please discontinue wearing or using the product. Continuous usage after symptoms subside might cause symptom reappearance. If the condition persist, please consult your doctor.
- This product contains electronic equipment, improper use might result in injury.
- To avoid exceeding the weight-bearing limit of this product, do not put this product inside bags directly or expose to any other heavy objects.
- This product has relatively low liquid ingress grade, avoid direct contact with water.
- Keep this product clean and dry regularly.
- Do not open the product outer case or disassemble it.

- Stop using the product immediately if any cracks were found.
- Substances contained in this product and its battery might jeopardize the environment or cause injury, please handle and dispose properly.
- Do not exert force, shake, or place this product in environment with excessive dust, or fluctuating temperature and humidity. Protect this product from vigorous shock or vibration.
- Do not place this product in any dishwashers, washing machines or dryers.
- Do not place this product under extreme temperatures.
- Do not place this product under long and direct sunlight exposure.
- Do not wipe this product with corrosive detergent.
- Do not allow this product to in contact with solvents, including, but not limited to alcohol, benzene or thinner, nor use damp cloth or solvents to clean this product. When the outer case of this product has cracked, it may induce short circuit, failure or fire.
- Do not disassemble or reassemble this product, it may cause injury or intoxication.
- Do not place this product in fire or heat up this product, nor place inflammable objects, including, but not limited to candles, near this product, otherwise it may cause fire or (battery) explosion.
- Do not wear this product while it is charging. 12.21 Do not charge this product when it is wet.
- Immediately stop wearing if you feel unusual heat emitted from this product.
- If there is any known condition that might affect normal use of this product, please consult your doctor in advance.

- Do not wear this product when handling hazardous tasks, it may cause accident or injury.
- Do not use this product in unsettling locations, including, but not limited to stairs or slope. Moreover, do not use this product in crowded or dim places, it may cause accident or injury.
- Please stay alert to the surroundings if using this product while walking. Too focusing on looking at the screen may cause accident or injury.
- Please be aware of the surroundings when using this product in compact area.
- Continuous or prolonged wearing of product may affect vision.
- Vision of children (especially pre-school children) is still under development, they should not use this product.
- Do not allow children or animals to chew or swallow the equipment.
- Do not use this product if lights will cause you allergy or nausea. Otherwise, the symptoms may exacerbate.
- Person who has chronic eye disease should not use this product, otherwise, symptoms, including, but not limited to strabismus, amblyopia or anisometropia, may exacerbate.
- Take regular breaks when using this product. Prolonged viewing image may cause eye fatigue or discomfort, stop using and take rest. Stop using immediately if fatigue or discomfort persists after resting.
- If problem or failure occurs, stop using this product immediately. Continue using this product may cause injury or induce nausea.
- If this product is to be taken to regions which prohibit the use of electromagnetic wave,

including, but not limited to planes, hospitals, the product should be turned off or having wireless LAN functions disabled, according to the regional instructions. Do not use wireless LAN functions near automatic control equipment, such as automatic doors or fire alarms. Disable the automatic power-on function before turning off this product. Electromagnetic wave may cause electromagnetic interference or failure to the medical equipment.

- Do not take this product into operating room, intensive care unit (ICU) or coronary care unit (CCU).
- Turn this product off in ward, or shut down the electromagnetic wave emission.
- Turn this product off or shut down the electromagnetic wave emission if there is electronic medical equipment nearby.
- Follow the medical regulations for prohibiting electromagnetic wave emitting equipment, these equipment is prohibited in special area.
- If you are implanted with a pacemaker or defibrillator, keep this product with your implanted device at least 22cm away when using. Make sure no one with a pacemaker is near before using this product, turn off the product if you are in a crowded place.
- Turn this product off or shut down the electromagnetic wave emission on planes.
- Eliminate static electricity from your body before using this product. To avoid electrostatic disturbance, make use of small metal piece (e.g. keys), cotton wipe, or other applicable objects, to touch the doors, door handles, faucets, etc., to eliminate static electricity, and then touching any of these objects with your bare hands.

- The production and manufacture of this product is subject to the national specification of sales territory. If you use this product outside the country of sales, please contact the support centre.
- To use this product for application in high degree of functional reliability/safety and precision, for example, transport-related equipment such as aviation, railways, shipping, vehicle, disaster prevention equipment, safety equipment, you should consider including failure insurance and redundancy into your application to maintain safety and reliability of the whole system, before using this product.
- This product is not designed for application that requires extremely high reliability/safety, such as aviation equipment, main communication equipment, nuclear power control or medical equipment directly related to medical use. User should access and judge for whether this product is suitable for application.
- Any unauthorized operating system updates may pose risk to your information.
- Do not duplicate the content in this guide for any use unless permitted by our company.

The MAD Gaze X5 Instructions Manual will be updated regularly, please visit www.madgaze.com/support from time to time to download the latest version of Quick User Guide. The online English version for the Guide shall prevail under all circumstances. Please scan the QR code below for demonstration and introduction of more MAD Gaze Ares preset applications.



19. FCC Statement

This device complies with Part 15 of the FCC rules. Operation is subject to the following two conditions: 1) this device may not cause harmful interference, and 2) this device must accept any interference received, including interference that may cause undesired operation.

Note: This equipment has been tested and found to comply with the limits for a Class B digital device, pursuant to part 15 of the FCC Rules. These limits are designed to provide reasonable protection against harmful interference in a residential installation. This equipment generates uses and can radiate radio frequency energy and, if not installed and used in accordance with the instructions, may cause harmful interference to radio communications. However, there is no guarantee that interference will not occur in particular installation. If this equipment does cause harmful interference to radio or television reception, which can be determined by turning the equipment off and on, the user is encouraged to try to correct the interference by one or more of the following measures:

- Reorient or relocate the receiving antenna.
- Increase the separation between the equipment and receiver.
- Connect the equipment into an outlet on a circuit different from that to which the receiver is connected.
- Consult the dealer or an experienced radio/TV technician for help.

Changes or modifications not expressly approved by the party responsible for compliance could void the user's authority to operate the equipment.

This equipment complies with FCC radiation exposure limits set forth for an uncontrolled environment. User should avoid un-intended operation of usage when it is collocated with other transmitters or antenna.

20. Frequently Asked Questions

Q: Why is the Navigation App not functioning?
A: When using the Navigation App, check if the network connection is normal, then go to Control Centre and turn on the "Location Services".

Q: What should I do if X5 does not response after long press of the power button?
A: Please try to charge X5, the power indicator will light up. If the device cannot power on after full charging, please contact Customer Service for maintenance.

Tutorial Video

Please visit www.madgaze.com/support

Update

The MAD Gaze X5 Instructions Manual will be updated regularly, please visit <http://www.madgaze.com/X5/support> from time to time to download the latest version of MAD Gaze X5 Instructions Manual. The online English version for the MAD Gaze X5 Instructions Manual shall prevail under all circumstances. Please scan the QR code below for demonstration and introduction of more MAD Gaze X5 preset applications.

