



**SGS-CSTC Standards Technical Services
(Shanghai) Co., Ltd.**

588 West Jindu Road, Xinqiao, Songjiang, 201612 Shanghai, China
 Telephone: +86 (0) 21 6191 5666
 Fax: +86 (0) 21 6191 5678
 ee.shanghai@sgs.com

Report No.: SHEM160600398402
 Page: 1 of 43

1 Cover Page

RF TEST REPORT

Application No.:	SHEM1606003984CR
Applicant:	Huangshan Goldenland Electronics Inc.
FCC ID:	2AI3URMAG7
Equipment Under Test (EUT): NOTE: The following sample(s) was/were submitted and identified by the client as	
Product Name:	Receiver
Model No.(EUT):	Mag7, Mag5, Mag3
Standards:	FCC PART 15 Subpart C: 2016
Date of Receipt:	2016-12-15
Date of Test:	2016-12-15 to 2017-2-7
Date of Issue:	2017-2-7
Test Result:	Pass*

* In the configuration tested, the EUT (Equipment under test) complied with the standards specified above.



The manufacturer should ensure that all products in series production are in conformity with the product sample detailed in this report. If the product in this report is used in any configuration other than that detailed in the report, the manufacturer must ensure the new system complies with all relevant standards.

The report must not be used by the client to claim product certification, approval, or endorsement by NVLAP, NIST, or any agency of the federal government. All test results in this report can be traceable to National or International Standards.

This document is issued by the Company subject to its General Conditions of Service printed overleaf, available on request or accessible at www.sgs.com/terms_and_conditions.htm and, for electronic format documents, subject to Terms and Conditions for Electronic Documents at www.sgs.com/terms_e-document.htm. Attention is drawn to the limitation of liability, indemnification and jurisdiction issues defined therein. Any holder of this document is advised that information contained hereon reflects the Company's findings at the time of its intervention only and within the limits of Client's instructions, if any. The Company's sole responsibility is to its Client and this document does not exonerate parties to a transaction from exercising all their rights and obligations under the transaction documents. This document cannot be reproduced except in full, without prior written approval of the Company. Any unauthorized alteration, forgery or falsification of the content or appearance of this document is unlawful and offenders may be prosecuted to the fullest extent of the law. Unless otherwise stated the results shown in this test report refer only to the sample(s) tested and such sample(s) are retained for 90 days only



2 Test Summary

Test Item	FCC Requirement	Test method	Result
Antenna Requirement	FCC Part 15, Subpart C Section 15.203/15.247 (c)	---	PASS
AC Power Line Conducted Emission	FCC Part 15, Subpart C Section 15.207	ANSI C63.10 (2013) Section 6.2	PASS
20dB Occupied Bandwidth	FCC Part 15, Subpart C Section 15.247 (a)(1)	ANSI C63.10 (2013) Section 6.9.2	PASS
Conducted Peak Output Power	FCC Part 15, Subpart C Section 15.247 (b)(2)	ANSI C63.10 (2013) Section 7.8.5	PASS
Carrier Frequencies Separation	FCC Part 15, Subpart C Section 15.247 (a)(1)	ANSI C63.10 (2013) Section 7.8.2	PASS
Hopping Channel Number	FCC Part 15, Subpart C Section 15.247 (a)(1)	ANSI C63.10 (2013) Section 7.8.3	PASS
Dwell Time	FCC Part 15, Subpart C Section 15.247 (a)(1)	ANSI C63.10 (2013) Section 7.8.4	PASS
Conducted Spurious Emissions and Band- edge	FCC Part 15, Subpart C Section 15.247(d)	ANSI C63.10 (2013) Section 7.8.6&7.8.8	PASS
Radiated Spurious Emissions and Band- edge	FCC Part 15, Subpart C Section 15.209&15.205	ANSI C63.10 (2013) Section 6.4&6.5&6.6&6.10	PASS

The models in report are all the same except the model name, only Mag7 was submitted for tests.



3 Contents

	Page
1 COVER PAGE	1
2 TEST SUMMARY	2
3 CONTENTS	3
4 GENERAL INFORMATION	4
4.1 CLIENT INFORMATION.....	4
4.2 GENERAL DESCRIPTION OF E.U.T.....	4
4.3 TECHNICAL SPECIFICATIONS.....	4
4.4 DESCRIPTION OF SUPPORT UNITS.....	4
4.5 TEST MODE.....	4
4.6 TEST LOCATION	5
4.7 TEST FACILITY	6
4.8 MEASUREMENT UNCERTAINTY	6
5 EQUIPMENTS USED DURING TEST	7
6 TEST RESULTS	9
6.1 E.U.T. TEST CONDITIONS	9
6.2 FREQUENCY HOPPING SYSTEM REQUIREMENT	9
6.3 ANTENNA REQUIREMENT.....	11
6.4 CONDUCTED EMISSIONS ON MAINS TERMINALS	13
6.5 20dB OCCUPIED BANDWIDTH.....	15
6.6 CONDUCTED PEAK OUTPUT POWER	18
6.7 CARRIER FREQUENCIES SEPARATED	21
6.8 HOPPING CHANNEL NUMBER.....	24
6.9 DWELL TIME	28
6.10 CONDUCTED SPURIOUS EMISSIONS AND BAND-EDGE	32
6.10.1 Conducted spurious emission.....	33
6.11 RADIATED SPURIOUS EMISSIONS AND BAND-EDGE.....	36
6.11.1 Radiated Spurious Emissions.....	39
6.11.2 Radiated Band edge	41
7 TEST SETUP PHOTOGRAPHS	43
8 EUT CONSTRUCTIONAL DETAILS	43

4 General Information

4.1 Client Information

Applicant:	Huangshan Goldenland Electronics Inc.
Address of Applicant:	North Industrial Park, Huizhou District, Huangshan, Anhui Province, P.R. China
Manufacturer:	Huangshan Goldenland Electronics Inc.
Address of Manufacturer:	North Industrial Park, Huizhou District, Huangshan, Anhui Province, P.R. China
Factory:	Huangshan Goldenland Electronics Inc.
Address of Factory:	North Industrial Park, Huizhou District, Huangshan, Anhui Province, P.R. China

4.2 General Description of E.U.T.

Product Description:	Mobile product with 915MHz transmitting function
Rated Input:	DC 11.1V by Li-on Rechargeable Battery Supply the EUT with full charged battery during the testing.

4.3 Technical Specifications

Operation Frequency:	902.5MHz-927.5MHz
Modulation Technique:	FHSS(GFSK)
Channel separation:	500kHz
Number of Channel:	At least 50
Antenna Type	internal antenna(AC-Q915M02)

4.4 Description of Support Units

The EUT has been tested with associated equipment below.

Description	Manufacturer	Model No.	Supplied by
/	/	/	/

4.5 Test Mode

Test Mode	Description of Test Mode
Hopping disabled mode	Using test software to control EUT working in continuous transmitting, and select channel and modulation type.
Hopping enabled mode	Using test software to control EUT working in continuous transmitting, and hopping on status.

The packet type used for the final test:

Test Item	Sequence			Test Frequency		
	0	4	9	Low 902.5MHz	Middle 915.2MHz	High 927.5MHz
CE	-	-	-	-	-	-
20dB OBW	-	-	-	√	√	√
Peak Power	-	-	-	√	√	-
CFS	√	√	√	-	-	-

This document is issued by the Company subject to its General Conditions of Service printed overleaf, available on request or accessible at www.sgs.com/terms_and_conditions.htm and, for electronic format documents, subject to Terms and Conditions for Electronic Documents at www.sgs.com/terms_e-document.htm. Attention is drawn to the limitation of liability, indemnification and jurisdiction issues defined therein. Any holder of this document is advised that information contained hereon reflects the Company's findings at the time of its intervention only and within the limits of Client's instructions, if any. The Company's sole responsibility is to its Client and this document does not exonerate parties to a transaction from exercising all their rights and obligations under the transaction documents. This document cannot be reproduced except in full, without prior written approval of the Company. Any unauthorized alteration, forgery or falsification of the content or appearance of this document is unlawful and offenders may be prosecuted to the fullest extent of the law. Unless otherwise stated the results shown in this test report refer only to the sample(s) tested and such sample(s) are retained for 90 days only



HCN	√	√	√	-	-	-
Dwell Time	√	√	√	-	-	-
CSE	-	-	-	√	√	√
Conducted Band-edge	-	-	-	√	√	√
RSE & Band-edge	-	-	-	√	√	√
99% OBW	-	-	-	√	√	√

4.6 Test Location

All tests were performed at:

SGS-CSTC Standards Technical Services (Shanghai) Co., Ltd.

588 West Jindu Road, Xinqiao, Songjiang, 201612 Shanghai, China

Tel: +86 21 6191 5666

Fax: +86 21 6191 5678

4.7 Test Facility

The test facility is recognized, certified, or accredited by the following organizations:

- **CNAS (No. CNAS L0599)**

CNAS has accredited SGS-CSTC Standards Technical Services (Shanghai) Co., Ltd. to ISO/IEC 17025:2005 General Requirements for the Competence of Testing and Calibration Laboratories (CNAS-CL01 Accreditation Criteria for the Competence of Testing and Calibration Laboratories) for the competence in the field of testing.

- **FCC – Registration No.: 402683**

SGS-CSTC Standards Technical Services (Shanghai) Co., Ltd. has been registered and fully described in a report filed with the Federal Communications Commission (FCC). The acceptance letter from the FCC is maintained in our files. Registration No.: 402683.

- **Industry Canada (IC) – IC Assigned Code: 8617A**

The 3m Semi-anechoic chamber of SGS-CSTC Standards Technical Services (Shanghai) Co., Ltd. has been registered by Certification and Engineering Bureau of Industry Canada for radio equipment testing with Registration No.: 8617A-1.

- **VCCI (Member No.: 3061)**

The 3m Semi-anechoic chamber and Shielded Room of SGS-CSTC Standards Technical Services (Shanghai) Co., Ltd. has been registered in accordance with the Regulations for Voluntary Control Measures with Registration No.: R-3868, C-4336, T-2221, G-830 respectively.

4.8 Measurement Uncertainty

No.	Parameter	Measurement Uncertainty
1	Radio Frequency	$< \pm 1 \times 10^{-5}$
2	Total RF power, conducted	$< \pm 1.5$ dB
3	RF power density, conducted	$< \pm 3$ dB
4	Spurious emissions, conducted	$< \pm 3$ dB
5	All emissions, radiated	$< \pm 6$ dB (Below 1GHz) $< \pm 6$ dB (Above 1GHz)
6	Temperature	$< \pm 1^{\circ}\text{C}$
7	Humidity	$< \pm 5$ %
8	DC and low frequency voltages	$< \pm 3$ %

5 Equipments Used during Test

No.	Equipment	Manufacturer	Model No.	Inventory No.	Cal. Date	Cal. Due date
1	Power Meter	R&S	NRP	SHEM057-1	2017-01-14	2018-01-13
2	Power Meter Sensor	R&S	NRP-Z22	SHEM136-1	2016-08-12	2017-08-11
3	Spectrum Analyzer	R&S	FSP-30	SHEM002-1	2017-01-14	2018-01-13
4	EMI Receiver	R&S	ESU40	SHEM051-1	2017-01-14	2018-01-13
5	EMI Receiver	R&S	ESR7	SHEM162-1	2017-01-14	2018-01-13
6	LISN	SCHWARZBECK	NSLK8127	SHEM061-1	2017-01-14	2018-01-13
7	LISN	EMCO	3816/2	SHEM019-1	2017-01-14	2018-01-13
8	Loop Antenna (9kHz to 30MHz)	R&S	FMZB1519	SHEM135-1	2017-01-14	2018-01-13
9	Broadband Antenna (25MHz to 2GHz)	SCHWARZBECK	VULB9168	SHEM048-1	2017-01-14	2018-01-13
10	Broadband Antenna (25MHz to 3GHz)	R&S	HL562	SHEM010-1	2017-01-14	2018-01-13
11	Horn Antenna (1GHz to 18GHz)	R&S	HF906	SHEM009-1	2017-01-14	2018-01-13
12	Horn Antenna (1GHz to 18GHz)	SCHWARZBECK	BBHA9120D	SHEM050-1	2017-01-14	2018-01-13
13	Horn Antenna (14GHz to 40GHz)	SCHWARZBECK	BBHA 9170	SHEM049-1	2017-01-14	2018-01-13
14	Pre-amplifier (9KHz – 2GHz)	TESEQ	LNA6900	SHEM074-1	2017-01-14	2018-01-13
15	Pre-amplifier (1GHz – 26.5GHz)	SCHWARZBECK	F0118-G40-BZ4	SHEM049-2	2017-01-14	2018-01-13
16	Pre-amplifie (14GHz – 40GHz)	SCHWARZBECK	F1840-G35-BZ3	SHEM050-2	2017-01-14	2018-01-13
17	Low Pass Filter	Mini-Circuits	VLF-2500	SHEM114-1		
18	High Pass Filter	LORCH	5BRX-2400	SHEM155-1	/	/
19	High-low Temperature Cabinet	Suzhou Zhihe	TL-40	SHEM087-1	2016-08-15	2017-08-14
20	AC Power Stabilizer	WOCEN	6100	SHEM045-1	2017-01-14	2018-01-13



**SGS-CSTC Standards Technical Services
(Shanghai) Co., Ltd.**

Report No.: SHEM160600398402

Page: 8 of 43

21	DC Power Supply	QJE	QJ30003SII	SHEM046-1	2017-01-14	2018-01-13
22	Signal Generator (Interferer)	R&S	SMR40	SHEM058-1	2016-08-12	2017-08-11
23	Signal Generator (Blocker)	R&S	SMJ100A	SHEM141-1	2017-01-14	2018-01-13
24	Splitter	ANRITSU CORP	MA1612A	SHEM159-1	/	/
25	Coupler	Mini-Circuits	803-S-1	SHEM113-1	/	/

This document is issued by the Company subject to its General Conditions of Service printed overleaf, available on request or accessible at www.sgs.com/terms_and_conditions.htm and, for electronic format documents, subject to Terms and Conditions for Electronic Documents at www.sgs.com/terms_e-document.htm. Attention is drawn to the limitation of liability, indemnification and jurisdiction issues defined therein. Any holder of this document is advised that information contained hereon reflects the Company's findings at the time of its intervention only and within the limits of Client's instructions, if any. The Company's sole responsibility is to its Client and this document does not exonerate parties to a transaction from exercising all their rights and obligations under the transaction documents. This document cannot be reproduced except in full, without prior written approval of the Company. Any unauthorized alteration, forgery or falsification of the content or appearance of this document is unlawful and offenders may be prosecuted to the fullest extent of the law. Unless otherwise stated the results shown in this test report refer only to the sample(s) tested and such sample(s) are retained for 90 days only

6 Test Results

6.1 E.U.T. test conditions

Requirements: 15.31(e) For intentional radiators, measurements of the variation of the input power or the radiated signal level of the fundamental frequency component of the emission, as appropriate, shall be performed with the supply voltage varied between 85% and 115% of the nominal rated supply voltage. For battery operated equipment, the equipment tests shall be performed using a new battery.

Operating Environment:	Temperature:	20.0 -25.0 °C
	Humidity:	35-75 % RH
	Atmospheric Pressure:	99.2 -102 kPa

Test frequencies: According to the 15.31(m) Measurements on intentional radiators or receivers, other than TV broadcast receivers, shall be performed and, if required, reported for each band in which the device can be operated with the device operating at the number of frequencies in each band specified in the following table:

Frequency range over which device operates	Number of frequencies	Location in the range of operation
1 MHz or less	1	Middle
1 to 10 MHz	2	1 near top and 1 near bottom
More than 10 MHz	3	1 near top, 1 near middle and 1 near bottom

Pursuant to Part 15.31(c) For swept frequency equipment, measurements shall be made with the frequency sweep stopped at those frequencies chosen for the measurements to be reported.

6.2 Frequency Hopping System Requirement

Test Requirement: Section 15.247 (a)(1), (g), (h) requirement:

The system shall hop to channel frequencies that are selected at the system hopping rate from a Pseudorandom ordered list of hopping frequencies. Each frequency must be used equally on the average by each transmitter. The system receivers shall have input bandwidths that match the hopping channel bandwidths of their corresponding transmitters and shall shift frequencies in synchronization with the transmitted signals.

Frequency hopping spread spectrum systems are not required to employ all available hopping channels during each transmission. However, the system, consisting of both the transmitter and the receiver, must be designed to comply with all of the regulations in this section should the transmitter be presented with a continuous data (or information) stream. In addition, a system employing short transmission bursts must comply with the definition of a frequency hopping system and must distribute its transmissions over the minimum number of hopping channels specified in this section.

The incorporation of intelligence within a frequency hopping spread spectrum system that permits the system to recognize other users within the spectrum band so that it individually and independently



chooses and adapts its hop sets to avoid hopping on occupied channels is permitted. The coordination of frequency hopping systems in any other manner for the express purpose of avoiding the simultaneous occupancy of individual hopping frequencies by multiple transmitters is not permitted.

Operational Description

There are 10 available hopping sequences:
 Hopping sequence 0 uses channels: 0, 10, 20, 30 ... 490.
 Hopping sequence 1 uses channels: 1, 11, 21, 31 ... 491.
 ...
 Hopping sequence 9 uses channels: 9, 19, 29, 39 ... 499.

For every hopping sequence the channels are organized in pseudorandom sequence in the internal table.

- 22, 5, 30, 20, 0, 4, 39, 2, 34, 7,
- 41, 48, 21, 47, 17, 27, 8, 24, 6, 1,
- 26, 31, 12, 23, 25, 19, 3, 9, 46, 29,
- 33, 32, 14, 37, 40, 10, 13, 36, 38, 44,
- 11, 35, 15, 18, 43, 42, 49, 45, 16, 28

These are frequency numbers inside the hopping sequence (row numbers), not the channel numbers.

For example, for the hopping sequence #2 the actual channel numbers used during transmission are:

- 222, 52, 302, 202, 02, 42, 392, 22, 342, 72,
- 412, 482, 212, 472, 172, 272, 82, 242, 62, 12,
- 262, 312, 122, 232, 252, 192, 32, 92, 462, 292,
- 332, 322, 142, 372, 402, 102, 132, 362, 382, 442,
- 112, 352, 152, 182, 432, 422, 492, 452, 162, 282

Not all 10 sequences may be available to the end user depending on the specific application.

User can select one of the available hopping sequences during system configuration. It is done manually by using keypad and user interface menu structure. It is referred to as "channel" in the user menu and documentation. The same hopping sequence has to be selected on both locator and display.

	Hopping sequence number									
	0	1	2	3	4	5	6	7	8	9
0	902.500	902.550	902.600	902.650	902.700	902.750	902.800	902.850	902.900	902.950
10	903.000	903.050	903.100	903.150	903.200	903.250	903.300	903.350	903.400	903.450
20	903.500	903.550	903.600	903.650	903.700	903.750	903.800	903.850	903.900	903.950
30	904.000	904.050	904.100	904.150	904.200	904.250	904.300	904.350	904.400	904.450
...										
240	914.500	914.550	914.600	914.650	914.700	914.750	914.800	914.850	914.900	914.950
250	915.000	915.050	915.100	915.150	915.200	915.250	915.300	915.350	915.400	915.450
260	915.500	915.550	915.600	915.650	915.700	915.750	915.800	915.850	915.900	915.950
...										
460	925.500	925.550	925.600	925.650	925.700	925.750	925.800	925.850	925.900	925.950
470	926.000	926.050	926.100	926.150	926.200	926.250	926.300	926.350	926.400	926.450
480	926.500	926.550	926.600	926.650	926.700	926.750	926.800	926.850	926.900	926.950
490	927.000	927.050	927.100	927.150	927.200	927.250	927.300	927.350	927.400	927.450
500	927.500									

This document is issued by the Company subject to its General Conditions of Service printed overleaf, available on request or accessible at www.sgs.com/terms_and_conditions.htm and, for electronic format documents, subject to Terms and Conditions for Electronic Documents at www.sgs.com/terms_e-document.htm. Attention is drawn to the limitation of liability, indemnification and jurisdiction issues defined therein. Any holder of this document is advised that information contained hereon reflects the Company's findings at the time of its intervention only and within the limits of Client's instructions, if any. The Company's sole responsibility is to its Client and this document does not exonerate parties to a transaction from exercising all their rights and obligations under the transaction documents. This document cannot be reproduced except in full, without prior written approval of the Company. Any unauthorized alteration, forgery or falsification of the content or appearance of this document is unlawful and offenders may be prosecuted to the fullest extent of the law. Unless otherwise stated the results shown in this test report refer only to the sample(s) tested and such sample(s) are retained for 90 days only

6.3 Antenna Requirement

Standard requirement:

15.203 requirement:

An intentional radiator shall be designed to ensure that no antenna other than that furnished by the responsible party shall be used with the device. The use of a permanently attached antenna or of an antenna that uses a unique coupling to the intentional radiator, the manufacturer may design the unit so that a broken antenna can be replaced by the user, but the use of a standard antenna jack or electrical connector is prohibited

15.247(b) (4) requirement:

The conducted output power limit specified in paragraph (b) of this section is based on the use of antennas with directional gains that do not exceed 6 dBi. Except as shown in paragraph (c) of this section, if transmitting antennas of directional gain greater than 6 dBi are used, the conducted output power from the intentional radiator shall be reduced below the stated values in paragraphs (b)(1), (b)(2), and (b)(3) of this section, as appropriate, by the amount in dB that the directional gain of the antenna exceeds 6 dBi.

EUT Antenna:

Internal antenna
AC-Q915M02
Gain:3dBi

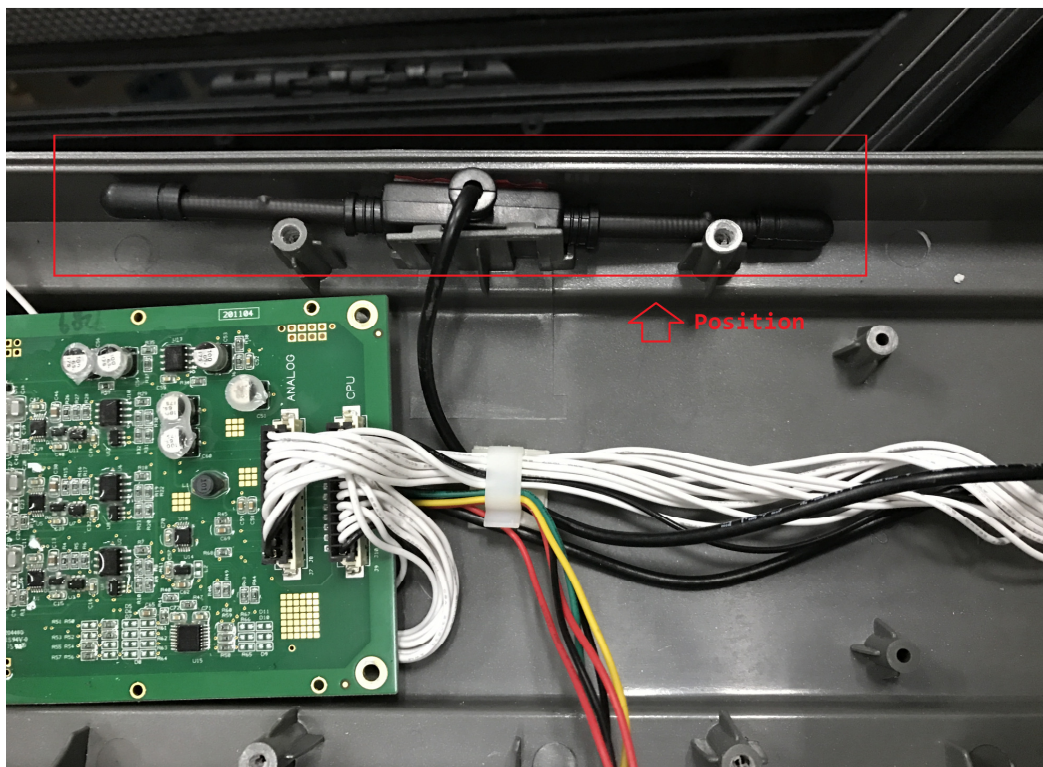

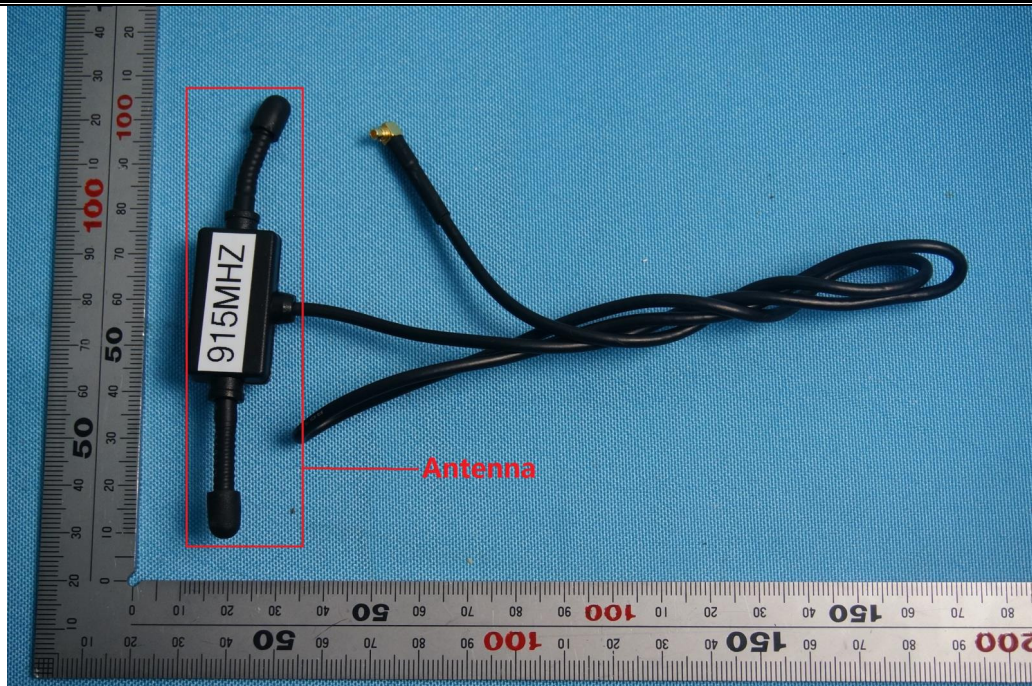

6.4 Conducted Emissions on Mains Terminals

Frequency Range: 150 KHz to 30 MHz

Limit:

Frequency range MHz	Class B Limits: dB (μ V)	
	Quasi-peak	Average
0.15 to 0.50	66 to 56	56 to 46
0.50 to 5	56	46
5 to 30	60	50

Note1: The limit decreases linearly with the logarithm of the frequency in the range 0.15 MHz to 0.50MHz.

Note2: The lower limit is applicable at the transition frequency.

Test Setup:

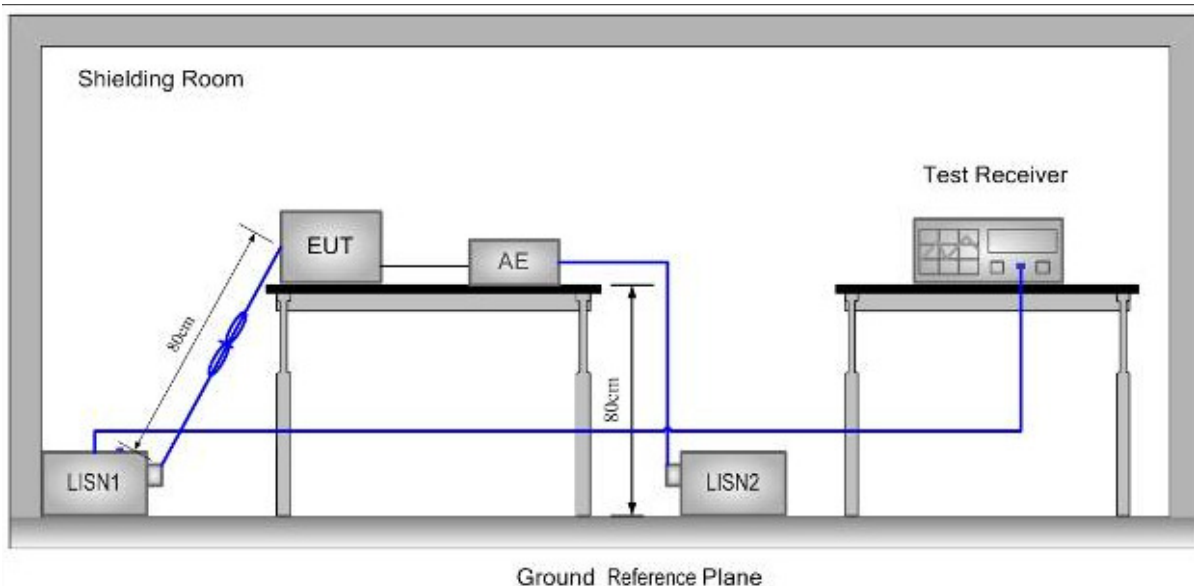

Test Procedure:

- 1) The mains terminal disturbance voltage was measured with the EUT in a shielded room.
- 2) The EUT was connected to AC power source through a LISN 1 (Line Impedance Stabilization Network) which provides $50\Omega/50\mu\text{H} + 5\Omega$ linear impedance. The power cables of all other units of the EUT were connected to a second LISN, which was bonded to the ground reference plane in the same way as the LISN for the unit being measured. A multiple socket outlet strip was used to connect multiple power cables to a single LISN provided the rating of the LISN was not exceeded.
- 3) The tabletop EUT was placed upon a non-metallic table 0.8m above the ground reference plane. And for floor-standing arrangement, the EUT was placed on the horizontal ground reference plane, but separated from metallic contact with the ground reference plane by 0.1m of insulation.
- 4) The test was performed with a vertical ground reference plane. The rear of the EUT shall be 0.4 m from the vertical ground reference plane. The vertical ground reference plane was bonded to the horizontal ground reference plane. The LISN was placed 0.8 m from the boundary of the unit under test and bonded to a ground reference plane for LISN mounted on top of the ground reference plane. This distance was between the closest points of the LISN and the EUT. The mains lead of EUT excess 0.8m was folded back and forth parallel to the lead so as to form a horizontal bundle with a length between 0.3m and 0.4m. All other units of the EUT and associated



equipment were at least 0.8 m from the LISN.

Remark: Pre-scan was performed with peak detected on all ports, Quasi-peak & average measurements were performed at the frequencies at which maximum peak emission level were detected. Pretest under all modes; choose the worst case mode (GFSK and Hopping enabled mode) record on the report. Please see the attached Quasi-peak and Average test results.

This EUT is powered by battery only; therefore the test on mains terminals is not applicable.

6.5 20dB Occupied Bandwidth

Test Configuration:

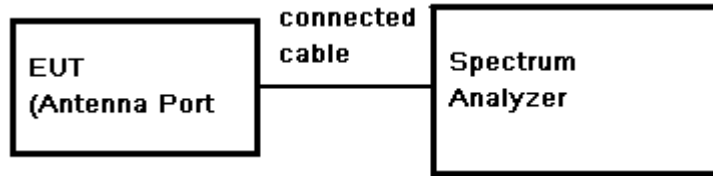

Test Procedure:

- 1) Remove the antenna from the EUT and then connect a low RF cable from the antenna port to the spectrum;
- 2) Set the spectrum analyzer: Span = approximately 2 to 5 times the OBW, centred on the hopping channel;
- 3) Set the spectrum analyzer: RBW \geq 1% to 5% of the OBW (set 10 kHz). VBW \geq RBW. Sweep = Auto; Detector = Peak. Trace = Max Hold.
- 4) Mark the peak frequency and -20dB points.

Test Date:

Test Frequency(MHz)	Bandwidth(kHz)
Low	75.6
Middle	76.0
High	75.6

Test plot as follows:

Test mode	channel: Low
-----------	--------------

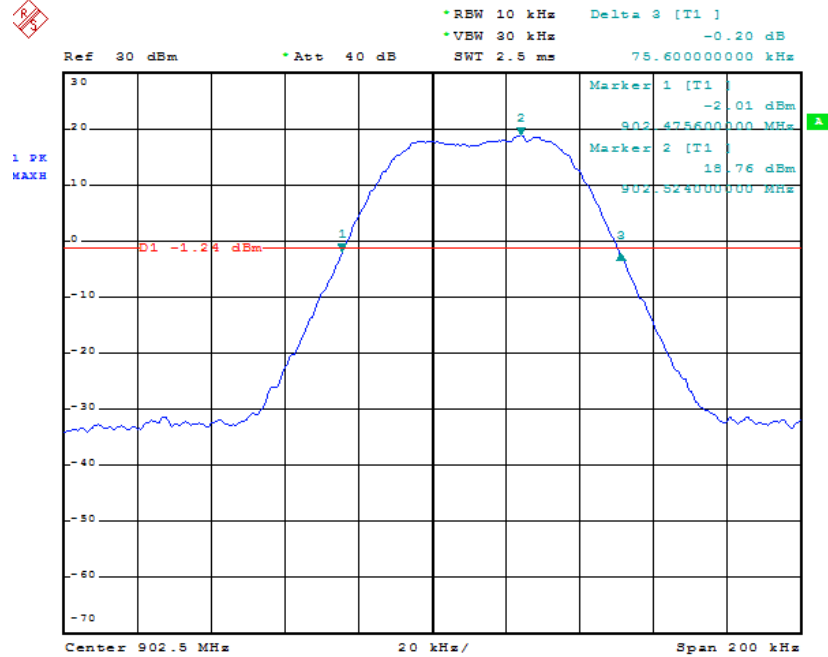

Test mode	channel: Middle
-----------	-----------------

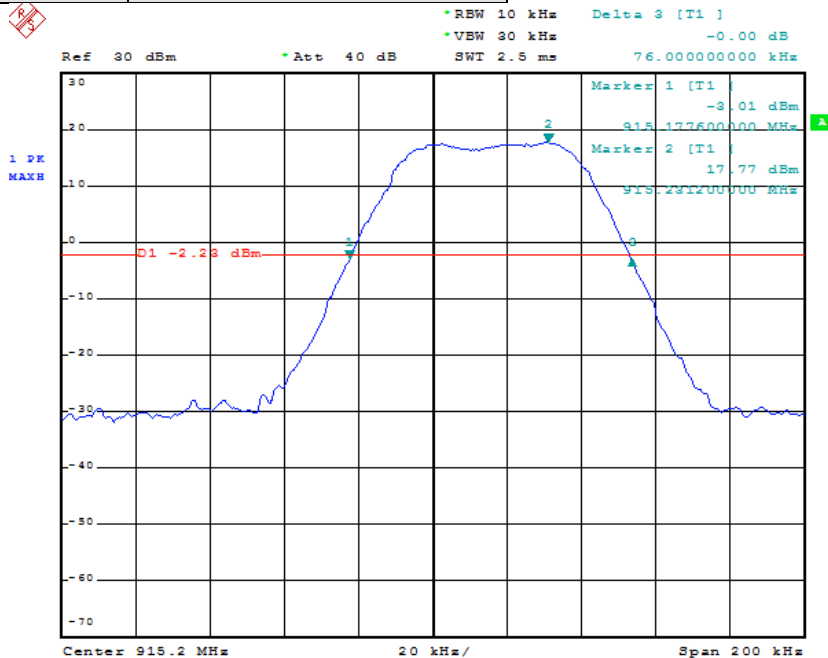



Test mode channel: High

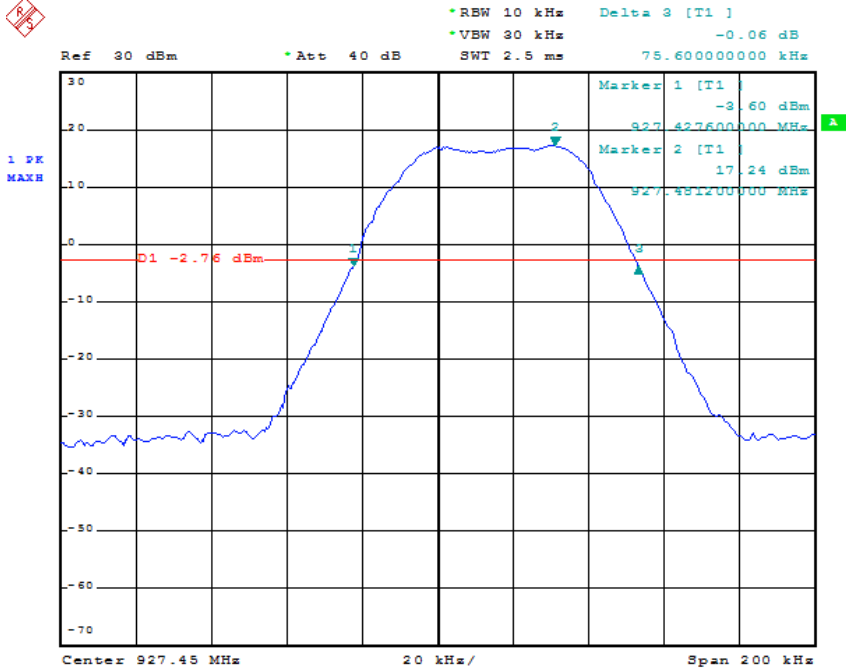

This document is issued by the Company subject to its General Conditions of Service printed overleaf, available on request or accessible at www.sgs.com/terms_and_conditions.htm and, for electronic format documents, subject to Terms and Conditions for Electronic Documents at www.sgs.com/terms_e-document.htm. Attention is drawn to the limitation of liability, indemnification and jurisdiction issues defined therein. Any holder of this document is advised that information contained hereon reflects the Company's findings at the time of its intervention only and within the limits of Client's instructions, if any. The Company's sole responsibility is to its Client and this document does not exonerate parties to a transaction from exercising all their rights and obligations under the transaction documents. This document cannot be reproduced except in full, without prior written approval of the Company. Any unauthorized alteration, forgery or falsification of the content or appearance of this document is unlawful and offenders may be prosecuted to the fullest extent of the law. Unless otherwise stated the results shown in this test report refer only to the sample(s) tested and such sample(s) are retained for 90 days only

6.6 Conducted Peak Output Power

Test Configuration:

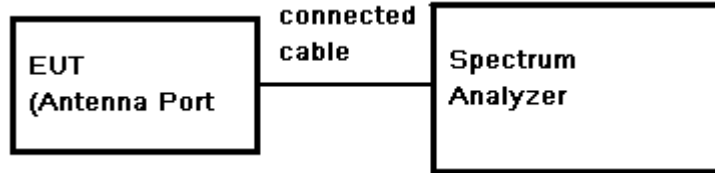

Test Procedure:

- 1) Remove the antenna from the EUT and then connect a low RF cable from the antenna port to the spectrum.
- 2) Set the spectrum analyzer: RBW = 3 MHz, VBW = 10 MHz, Sweep = auto; Detector Function = Peak.
- 3) Keep the EUT in transmitting at lowest, middle and highest channel individually. Record the max value.

Test Limit:

Regulation 15.247 (b)(2)

For frequency hopping systems operating in the 902–928 MHz band: 1 watt for systems employing at least 50 hopping channels; and 0.25 watts for systems employing less than 50 hopping channels, but at least 25 hopping channels, as permitted under paragraph (a)(1)(i) of this section.

Test Data:

Test Frequency (MHz)	Reading Power (dBm)	Cable Loss (dB)	Output Power (dBm)	Limit (dBm)	Test Result
Low	19.5	0.5	20.0	30	Pass
Middle	19.22		19.72		Pass
High	18.83		19.33		Pass

Remark: Output Power=Reading Power + Cable loss

Test plot as follows:

Test mode	channel: Low
-----------	--------------

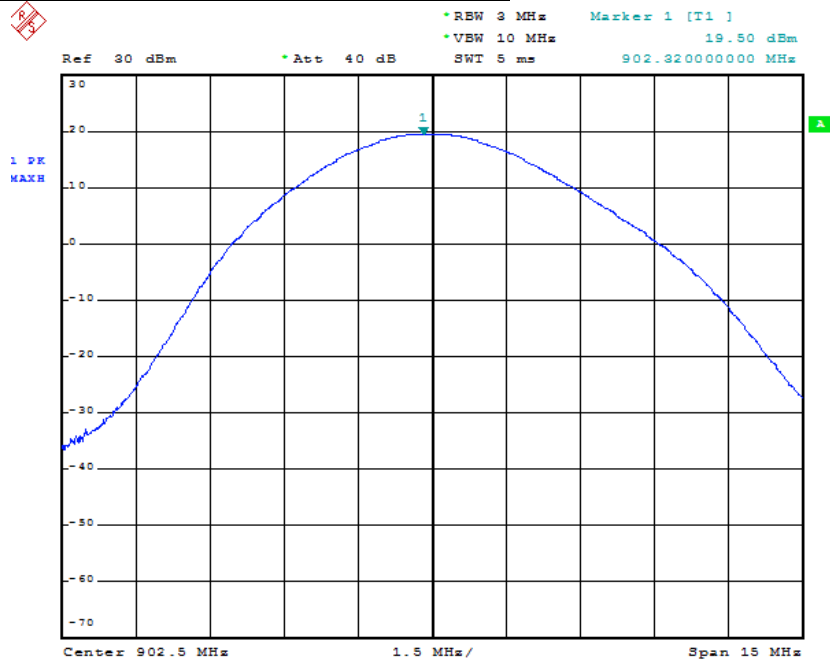

Test mode	channel: Middle
-----------	-----------------

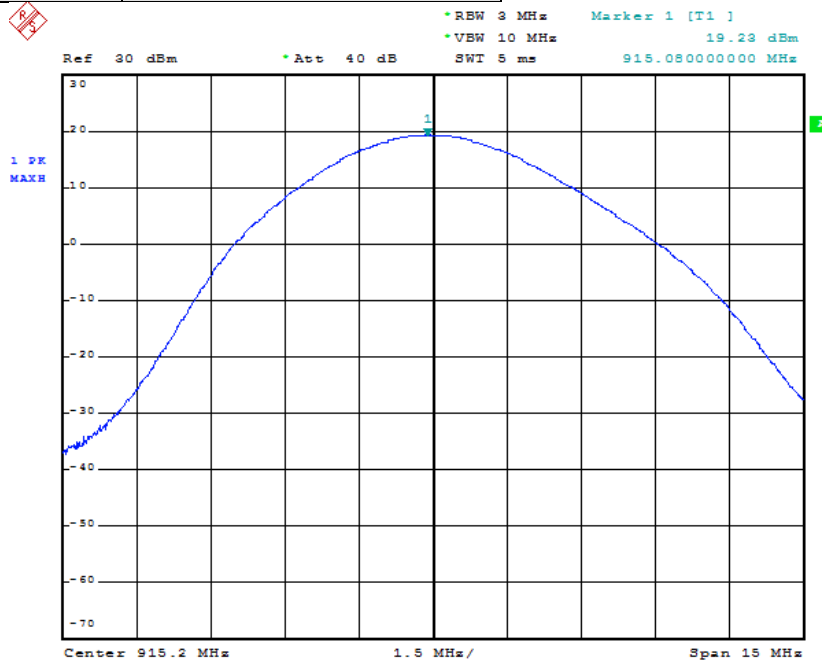

This document is issued by the Company subject to its General Conditions of Service printed overleaf, available on request or accessible at www.sgs.com/terms_and_conditions.htm and, for electronic format documents, subject to Terms and Conditions for Electronic Documents at www.sgs.com/terms_e-document.htm. Attention is drawn to the limitation of liability, indemnification and jurisdiction issues defined therein. Any holder of this document is advised that information contained hereon reflects the Company's findings at the time of its intervention only and within the limits of Client's instructions, if any. The Company's sole responsibility is to its Client and this document does not exonerate parties to a transaction from exercising all their rights and obligations under the transaction documents. This document cannot be reproduced except in full, without prior written approval of the Company. Any unauthorized alteration, forgery or falsification of the content or appearance of this document is unlawful and offenders may be prosecuted to the fullest extent of the law. Unless otherwise stated the results shown in this test report refer only to the sample(s) tested and such sample(s) are retained for 90 days only



Test mode channel: High



• RBW 3 MHz Marker 1 [T1]
• VBW 10 MHz 18.88 dBm
• Att 40 dB
• Ref 30 dBm
• SWI 5 ms 927.39000000 MHz

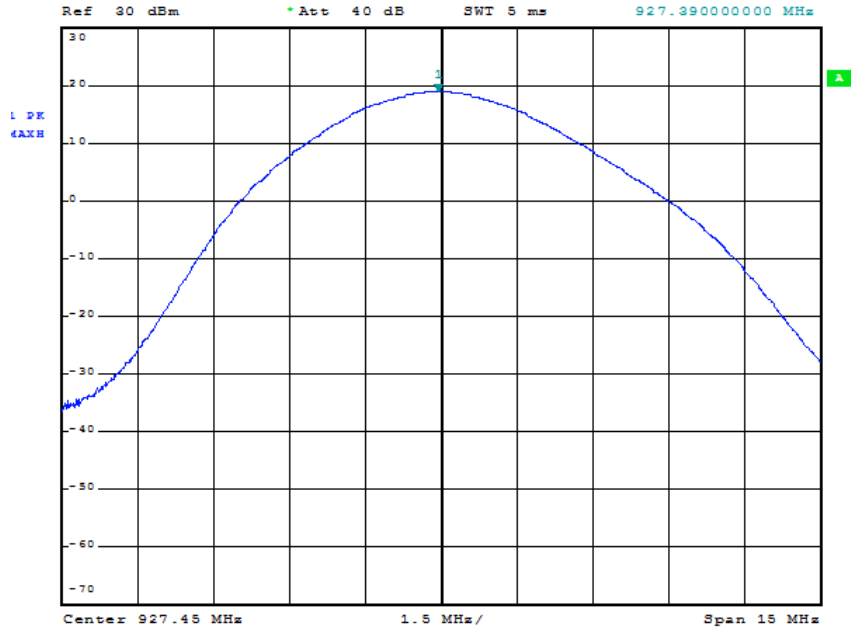

This document is issued by the Company subject to its General Conditions of Service printed overleaf, available on request or accessible at www.sgs.com/terms_and_conditions.htm and, for electronic format documents, subject to Terms and Conditions for Electronic Documents at www.sgs.com/terms_e-document.htm. Attention is drawn to the limitation of liability, indemnification and jurisdiction issues defined therein. Any holder of this document is advised that information contained hereon reflects the Company's findings at the time of its intervention only and within the limits of Client's instructions, if any. The Company's sole responsibility is to its Client and this document does not exonerate parties to a transaction from exercising all their rights and obligations under the transaction documents. This document cannot be reproduced except in full, without prior written approval of the Company. Any unauthorized alteration, forgery or falsification of the content or appearance of this document is unlawful and offenders may be prosecuted to the fullest extent of the law. Unless otherwise stated the results shown in this test report refer only to the sample(s) tested and such sample(s) are retained for 90 days only

6.7 Carrier Frequencies Separated

Test Configuration:

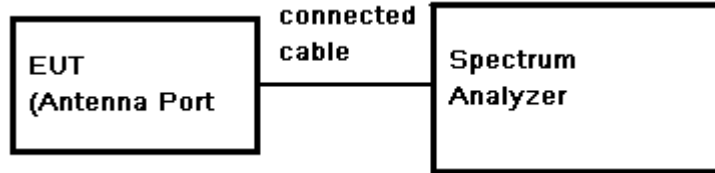

Test Procedure:

- 1) Remove the antenna from the EUT and then connect a low RF cable from the antenna port to the spectrum.
- 2) Set the spectrum analyzer: RBW \geq 1% of the span (set 30 kHz). VBW \geq RBW, Span = 3MHz. Sweep = auto; Detector Function = Peak. Trace = Maxhold.
- 3) Allow the trace to stabilize. Use the marker-delta function to determine the separation between the peaks of the adjacent channels. The limit is specified in one of the subparagraphs of this Section. Submit this plot.

Limit:

0.025MHz or 20dB bandwidth (whichever is greater)

Test data:

Test Sequence	Carrier Frequencies Separated (kHz)	Limit	Test Result
0	498	75.6	Pass
4	501	76.0	Pass
9	495	75.6	Pass

Remark: 20dB bandwidth reference Section 6.5

Test plot as follows:

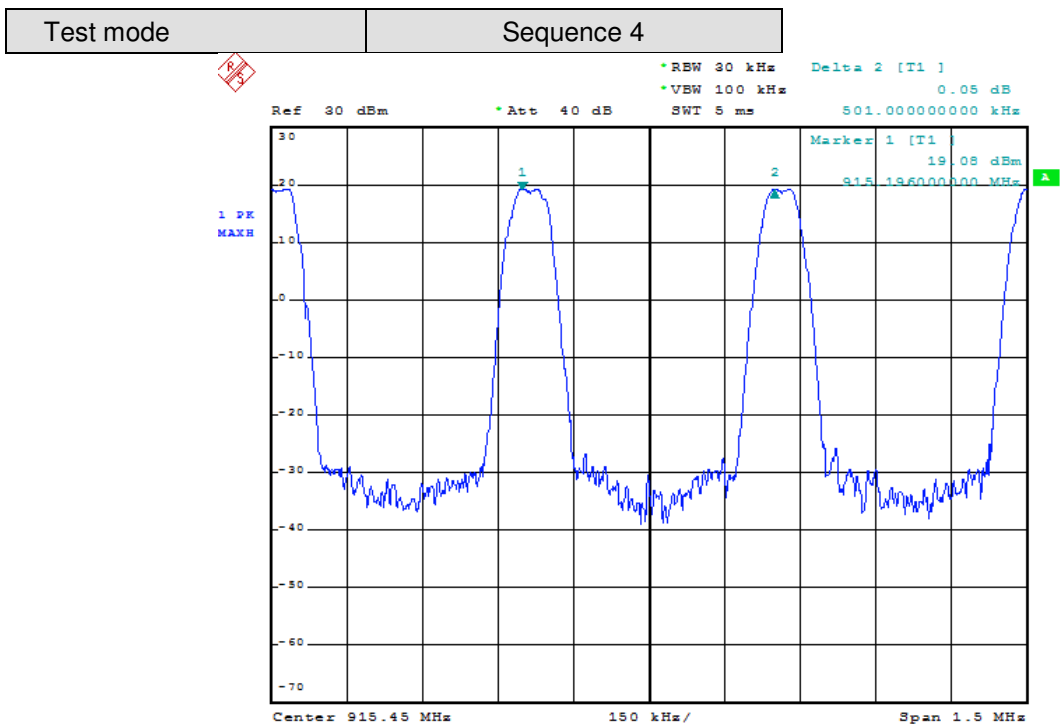
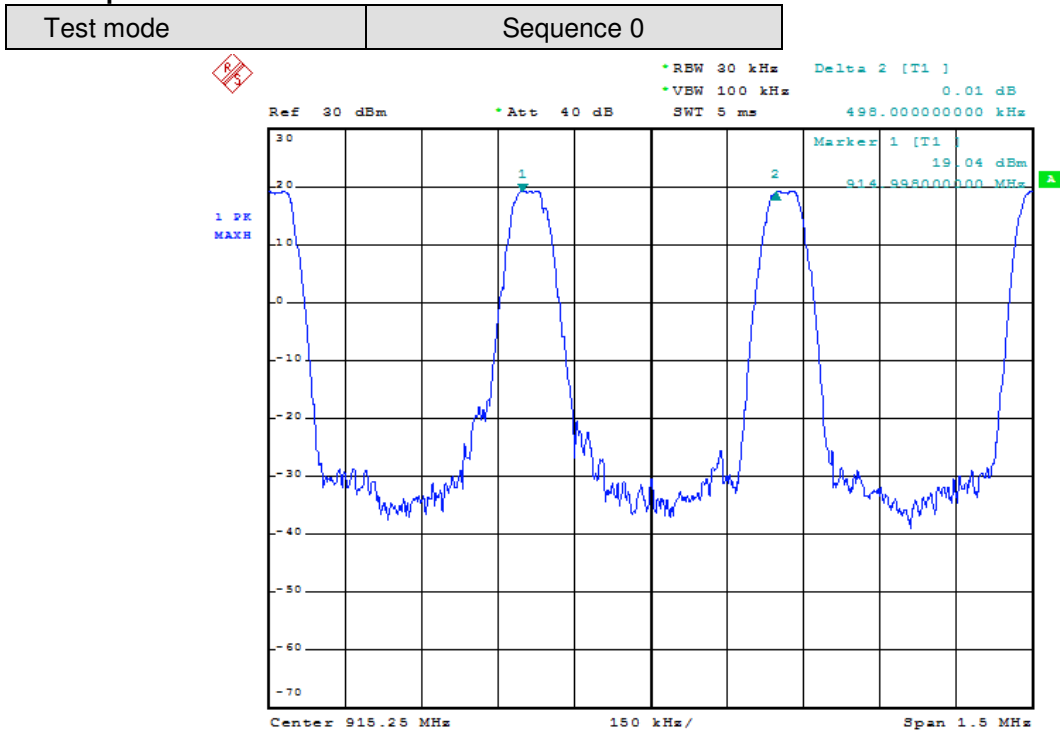

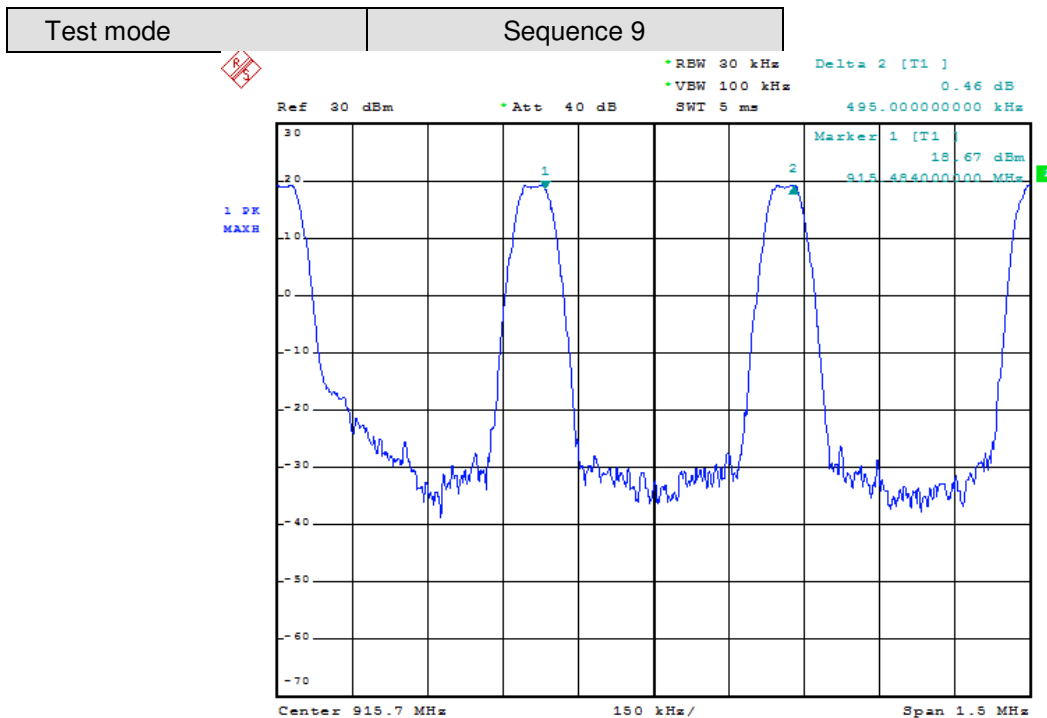

This document is issued by the Company subject to its General Conditions of Service printed overleaf, available on request or accessible at www.sgs.com/terms_and_conditions.htm and, for electronic format documents, subject to Terms and Conditions for Electronic Documents at www.sgs.com/terms_e-document.htm. Attention is drawn to the limitation of liability, indemnification and jurisdiction issues defined therein. Any holder of this document is advised that information contained hereon reflects the Company's findings at the time of its intervention only and within the limits of Client's instructions, if any. The Company's sole responsibility is to its Client and this document does not exonerate parties to a transaction from exercising all their rights and obligations under the transaction documents. This document cannot be reproduced except in full, without prior written approval of the Company. Any unauthorized alteration, forgery or falsification of the content or appearance of this document is unlawful and offenders may be prosecuted to the fullest extent of the law. Unless otherwise stated the results shown in this test report refer only to the sample(s) tested and such sample(s) are retained for 90 days only

6.8 Hopping Channel Number

Test Configuration:

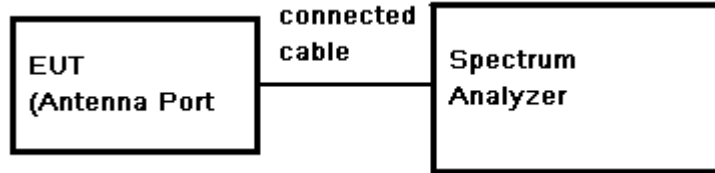

Test Procedure:

- 1) Remove the antenna from the EUT and then connect a low RF cable from the antenna port to the spectrum.
- 2) Set the spectrum analyzer: RBW = 300 kHz. VBW = 300 kHz. Sweep = auto; Detector Function = Peak. Trace = Max hold.
- 3) Allow the trace to stabilize. It may prove necessary to break the span up to sections. in order to clearly show all of the hopping frequencies. The limit is specified in one of the subparagraphs of this Section.
- 4) Set the spectrum analyzer: start frequency = 902MHz. stop frequency = 928MHz. Submit the test result graph.

Regulation 15.247(a)(1) (i) For frequency hopping systems operating in the 902–928 MHz band: if the 20 dB bandwidth of the hopping channel is less than 250 kHz, the system shall use at least 50 hopping frequencies and the average time of occupancy on any frequency shall not be greater than 0.4 seconds within a 20 second period; if the 20 dB bandwidth of the hopping channel is 250 kHz or greater, the system shall use at least 25 hopping frequencies and the average time of occupancy on any frequency shall not be greater than 0.4 seconds within a 10 second period. The maximum allowed 20 dB bandwidth of the hopping channel is 500 kHz.

Limit:

Test Data:

Hopping channel numbers	Limit	Test Result
50	≥50	Pass

**Test plot as follows:
Sequence 0**

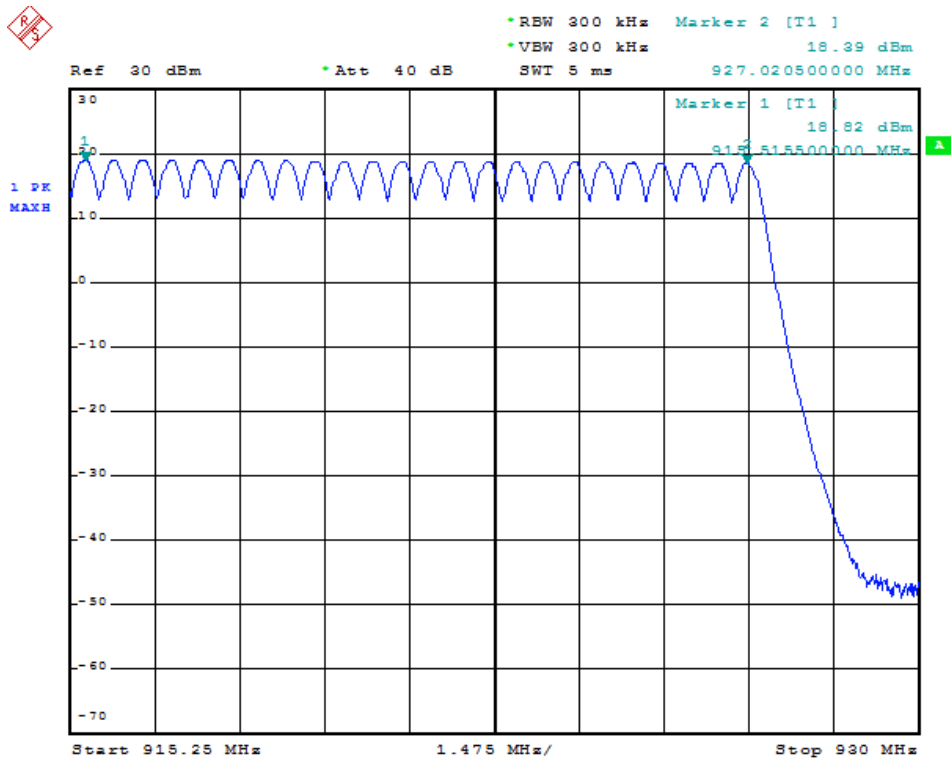
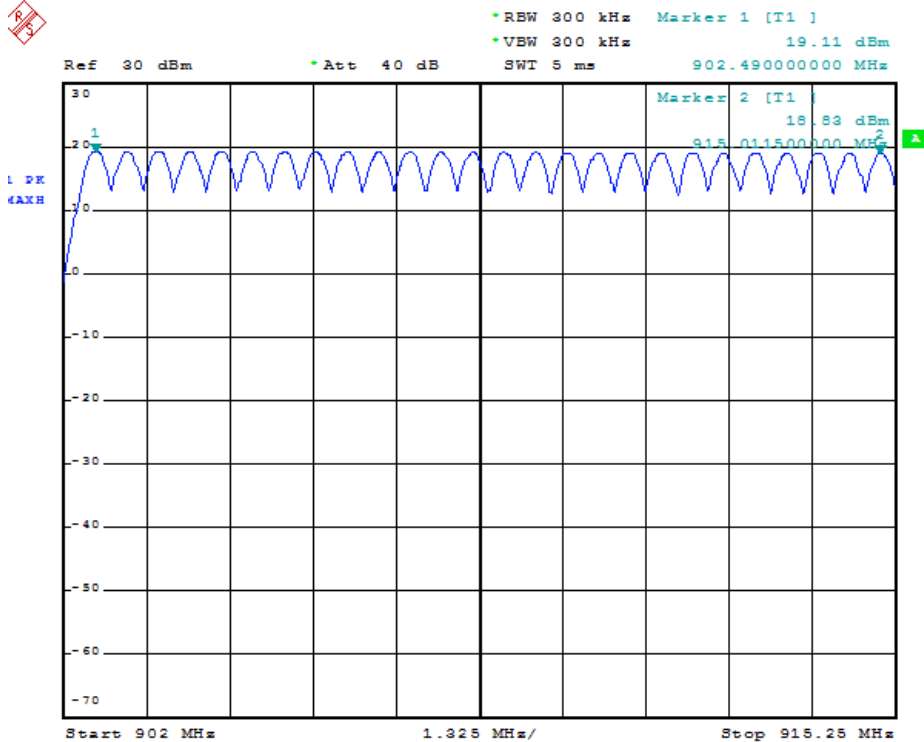

This document is issued by the Company subject to its General Conditions of Service printed overleaf, available on request or accessible at www.sgs.com/terms_and_conditions.htm and, for electronic format documents, subject to Terms and Conditions for Electronic Documents at www.sgs.com/terms_e-document.htm. Attention is drawn to the limitation of liability, indemnification and jurisdiction issues defined therein. Any holder of this document is advised that information contained hereon reflects the Company's findings at the time of its intervention only and within the limits of Client's instructions, if any. The Company's sole responsibility is to its Client and this document does not exonerate parties to a transaction from exercising all their rights and obligations under the transaction documents. This document cannot be reproduced except in full, without prior written approval of the Company. Any unauthorized alteration, forgery or falsification of the content or appearance of this document is unlawful and offenders may be prosecuted to the fullest extent of the law. Unless otherwise stated the results shown in this test report refer only to the sample(s) tested and such sample(s) are retained for 90 days only

Sequence 4

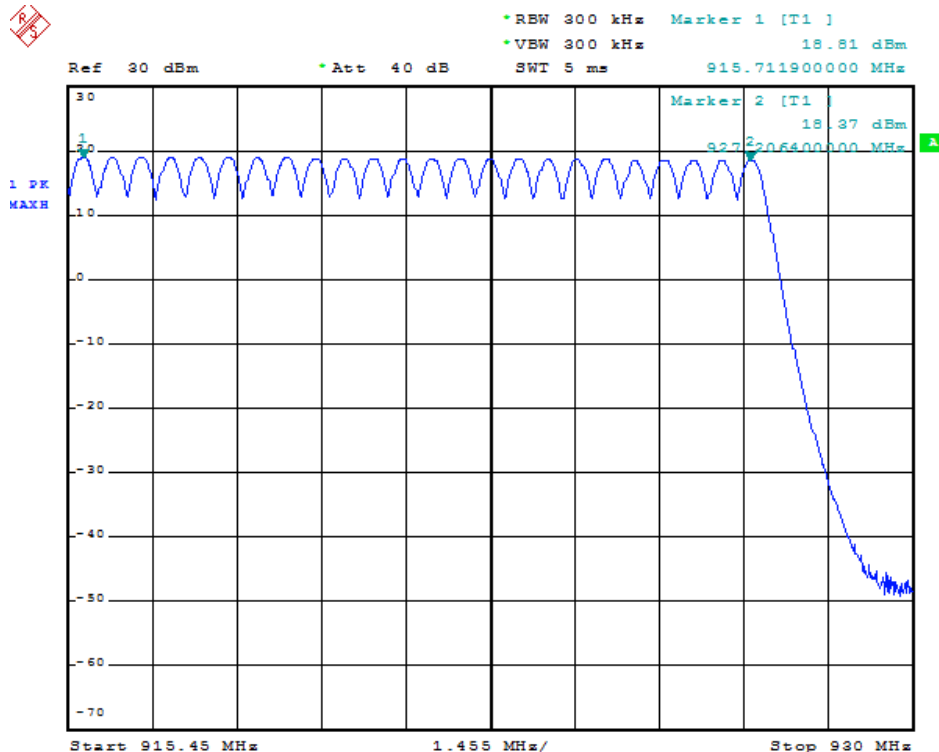
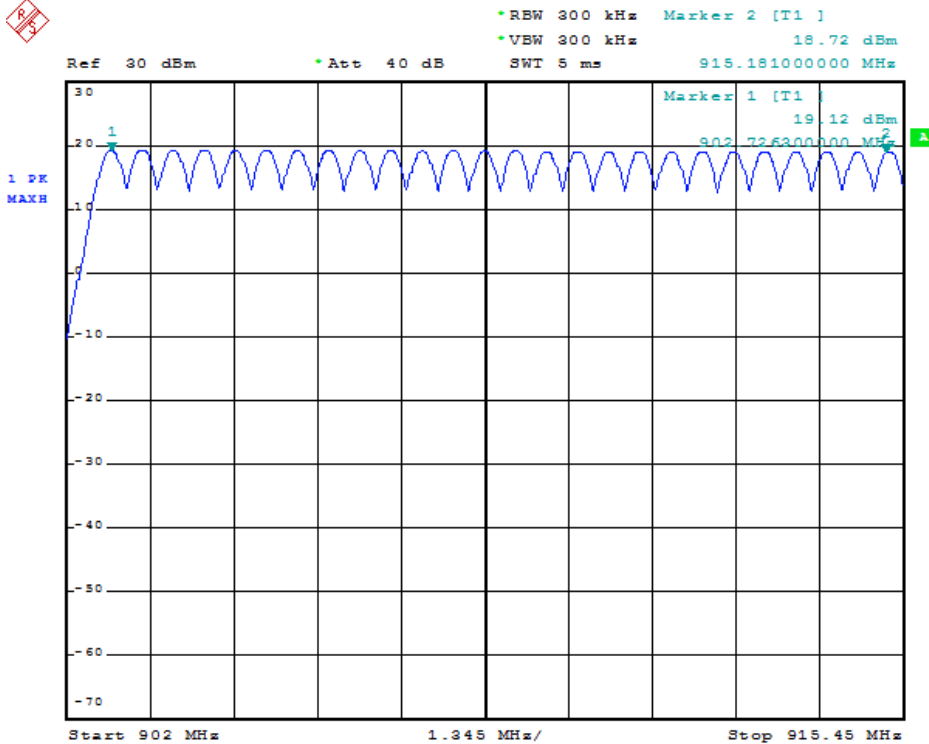

Sequence 9

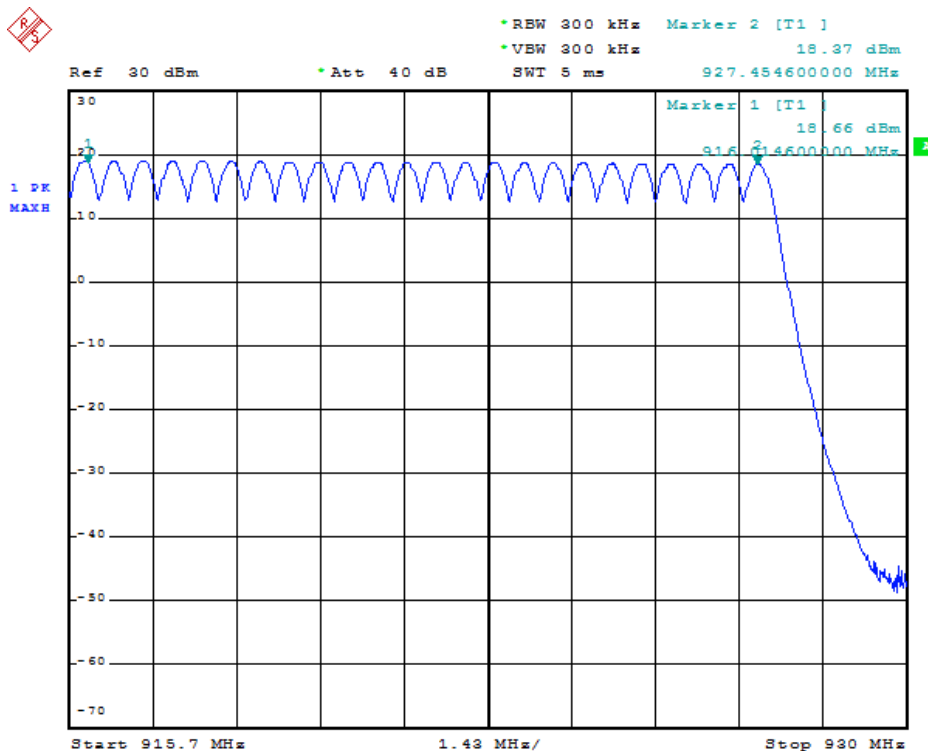
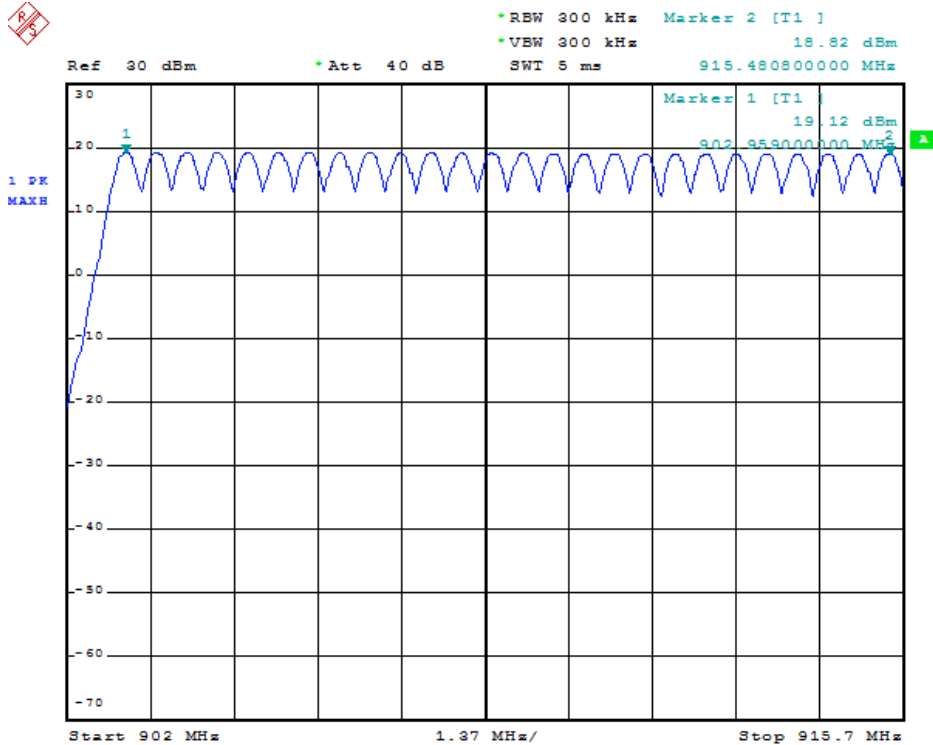

This document is issued by the Company subject to its General Conditions of Service printed overleaf, available on request or accessible at www.sgs.com/terms_and_conditions.htm and, for electronic format documents, subject to Terms and Conditions for Electronic Documents at www.sgs.com/terms_e-document.htm. Attention is drawn to the limitation of liability, indemnification and jurisdiction issues defined therein. Any holder of this document is advised that information contained hereon reflects the Company's findings at the time of its intervention only and within the limits of Client's instructions, if any. The Company's sole responsibility is to its Client and this document does not exonerate parties to a transaction from exercising all their rights and obligations under the transaction documents. This document cannot be reproduced except in full, without prior written approval of the Company. Any unauthorized alteration, forgery or falsification of the content or appearance of this document is unlawful and offenders may be prosecuted to the fullest extent of the law. Unless otherwise stated the results shown in this test report refer only to the sample(s) tested and such sample(s) are retained for 90 days only

6.9 Dwell Time

Test Configuration:

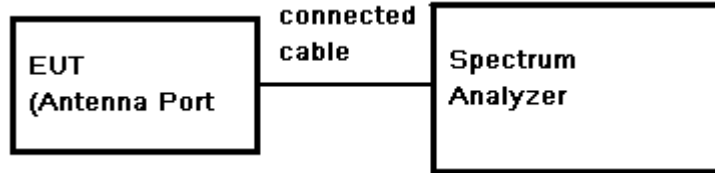

Test Procedure:

- 1) Remove the antenna from the EUT and then connect a low RF cable from the antenna port to the spectrum. Keep EUT in Hopping transmitting with all kind of modulation.
- 2) Set spectrum analyzer span = 0. centered on a hopping channel;
- 3) Use Emission width * No. of Hopping Channels in 31.6s to determine the dwell time.

Limit:

Regulation 15.247(a)(1) (i) For frequency hopping systems operating in the 902–928 MHz band: if the 20 dB bandwidth of the hopping channel is less than 250 kHz, the system shall use at least 50 hopping frequencies and the average time of occupancy on any frequency shall not be greater than 0.4 seconds within a 20 second period; if the 20 dB bandwidth of the hopping channel is 250 kHz or greater, the system shall use at least 25 hopping frequencies and the average time of occupancy on any frequency shall not be greater than 0.4 seconds within a 10 second period. The maximum allowed 20 dB bandwidth of the hopping channel is 500 kHz.

Test Data:

Sequence	Emission Width (ms)	Number of Hopping Channel in 20s	Average Occupancy Time (s)	Limit(s)	Test Result
0	113.4	2	0.2268	0.4	Pass
4	114.8	2	0.2296		Pass
9	114.8	2	0.2296		Pass



Test plot as follows:

Test mode	Sequence 0
-----------	------------

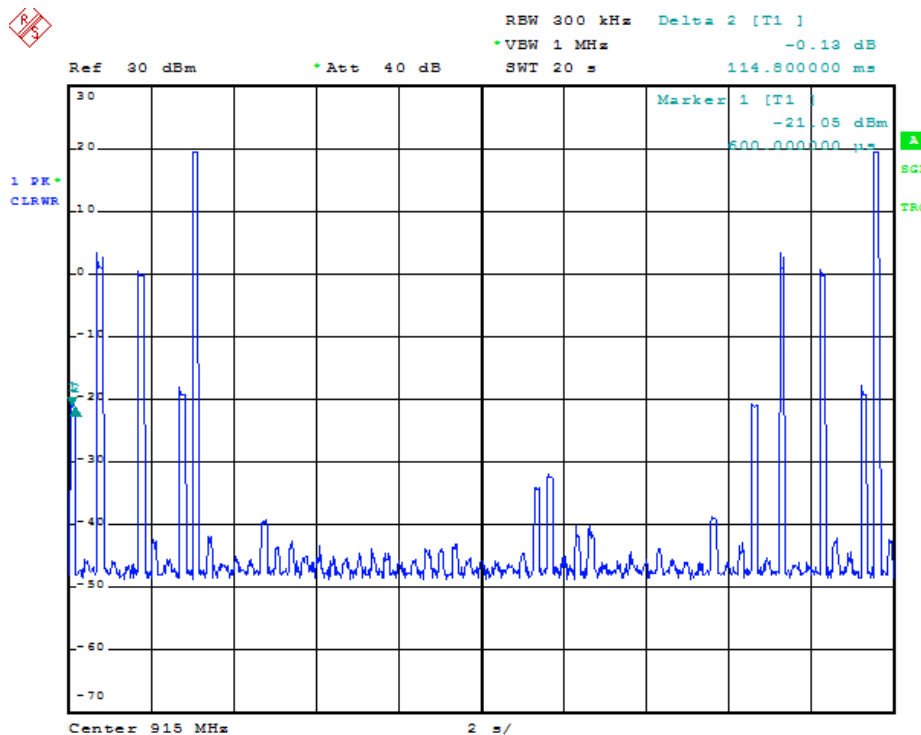
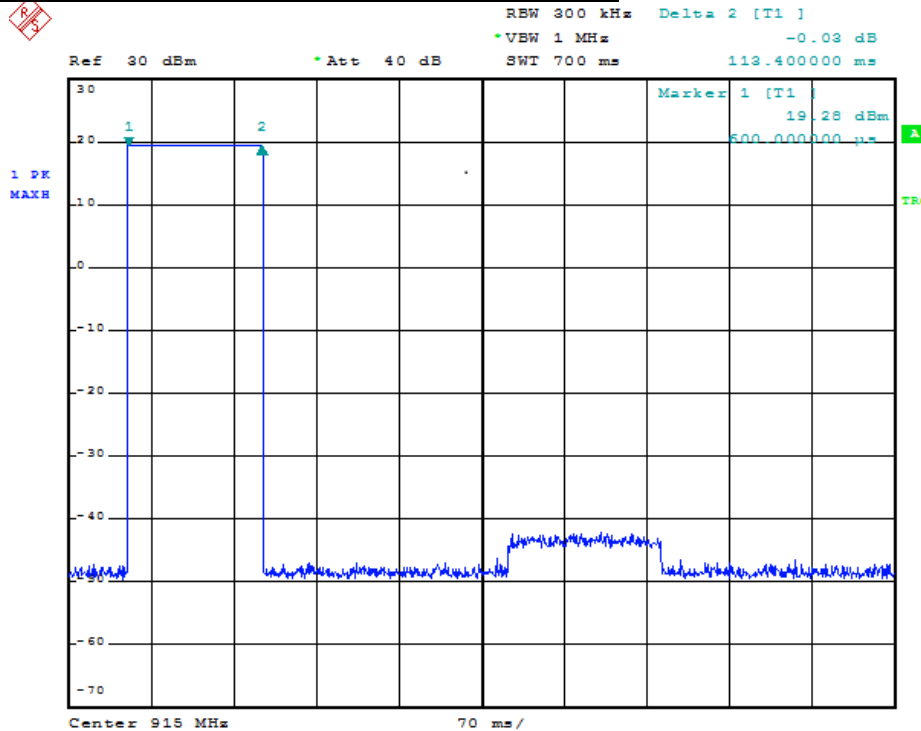

This document is issued by the Company subject to its General Conditions of Service printed overleaf, available on request or accessible at www.sgs.com/terms_and_conditions.htm and, for electronic format documents, subject to Terms and Conditions for Electronic Documents at www.sgs.com/terms_e-document.htm. Attention is drawn to the limitation of liability, indemnification and jurisdiction issues defined therein. Any holder of this document is advised that information contained herein reflects the Company's findings at the time of its intervention only and within the limits of Client's instructions, if any. The Company's sole responsibility is to its Client and this document does not exonerate parties to a transaction from exercising all their rights and obligations under the transaction documents. This document cannot be reproduced except in full, without prior written approval of the Company. Any unauthorized alteration, forgery or falsification of the content or appearance of this document is unlawful and offenders may be prosecuted to the fullest extent of the law. Unless otherwise stated the results shown in this test report refer only to the sample(s) tested and such sample(s) are retained for 90 days only

Test mode	Sequence 4
-----------	------------

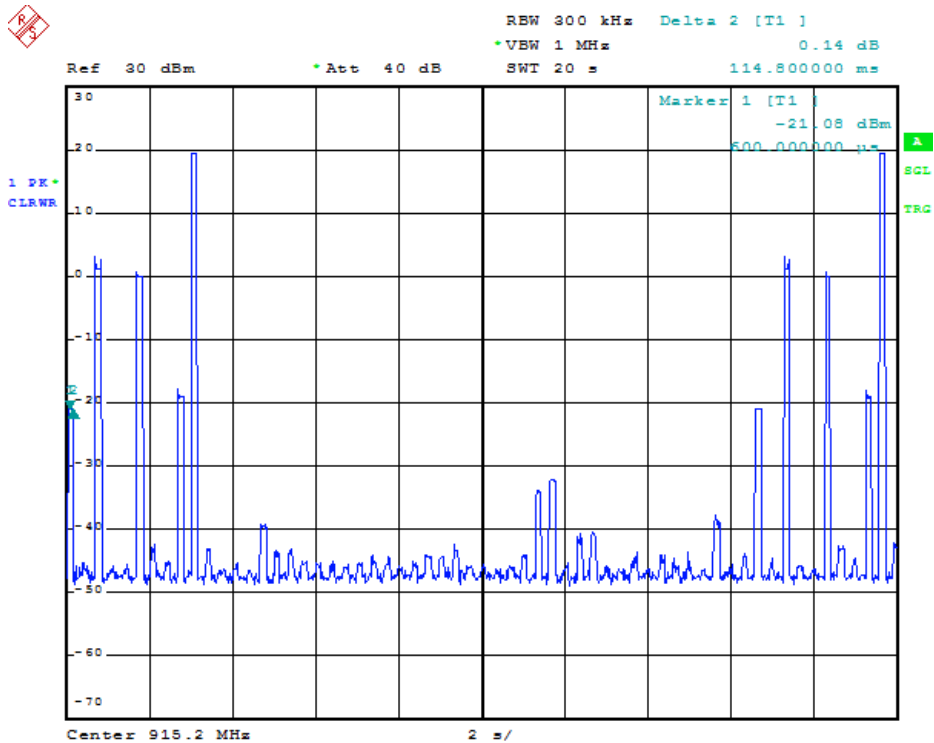
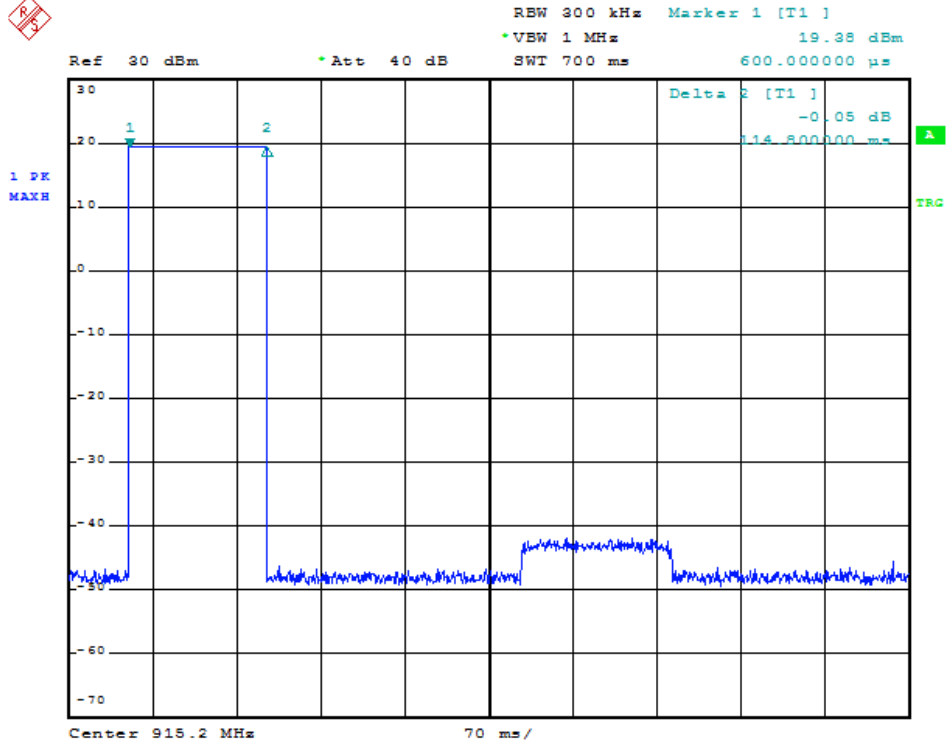

This document is issued by the Company subject to its General Conditions of Service printed overleaf, available on request or accessible at www.sgs.com/terms_and_conditions.htm and, for electronic format documents, subject to Terms and Conditions for Electronic Documents at www.sgs.com/terms_e-document.htm. Attention is drawn to the limitation of liability, indemnification and jurisdiction issues defined therein. Any holder of this document is advised that information contained herein reflects the Company's findings at the time of its intervention only and within the limits of Client's instructions, if any. The Company's sole responsibility is to its Client and this document does not exonerate parties to a transaction from exercising all their rights and obligations under the transaction documents. This document cannot be reproduced except in full, without prior written approval of the Company. Any unauthorized alteration, forgery or falsification of the content or appearance of this document is unlawful and offenders may be prosecuted to the fullest extent of the law. Unless otherwise stated the results shown in this test report refer only to the sample(s) tested and such sample(s) are retained for 90 days only

Test mode:DH5 Sequence 9

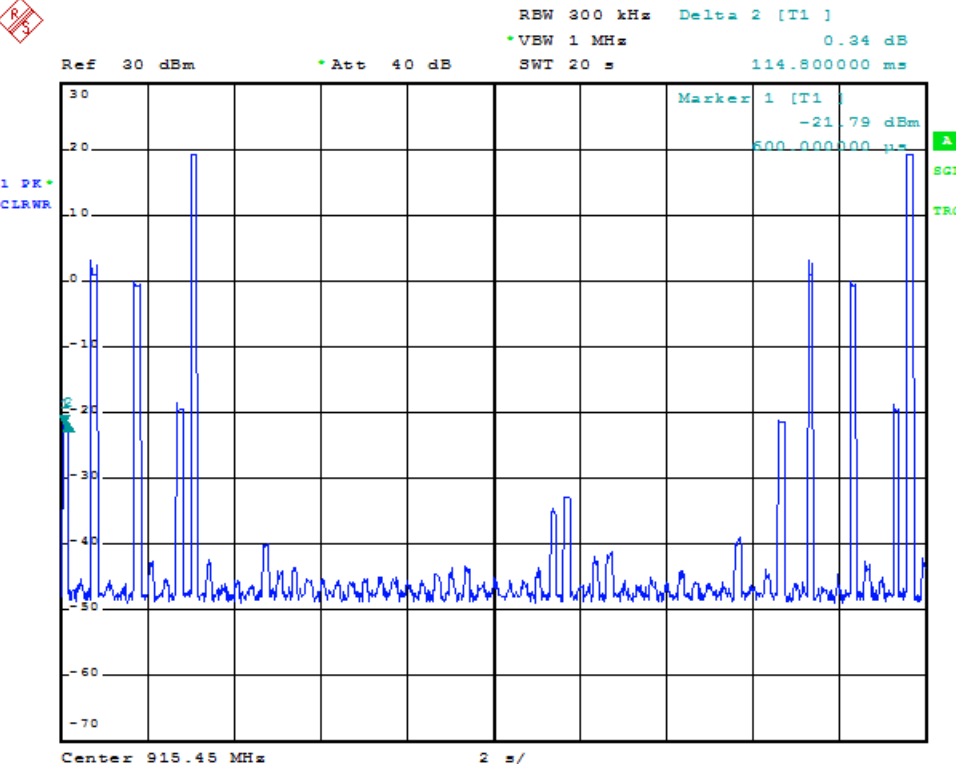
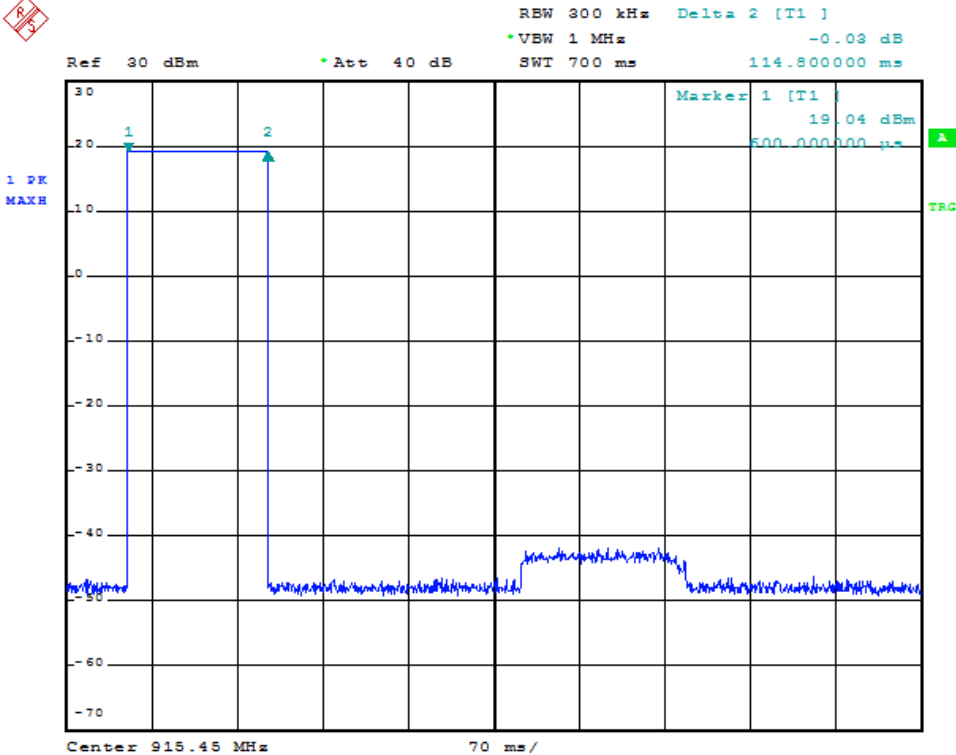

This document is issued by the Company subject to its General Conditions of Service printed overleaf, available on request or accessible at www.sgs.com/terms_and_conditions.htm and, for electronic format documents, subject to Terms and Conditions for Electronic Documents at www.sgs.com/terms_e-document.htm. Attention is drawn to the limitation of liability, indemnification and jurisdiction issues defined therein. Any holder of this document is advised that information contained hereon reflects the Company's findings at the time of its intervention only and within the limits of Client's instructions, if any. The Company's sole responsibility is to its Client and this document does not exonerate parties to a transaction from exercising all their rights and obligations under the transaction documents. This document cannot be reproduced except in full, without prior written approval of the Company. Any unauthorized alteration, forgery or falsification of the content or appearance of this document is unlawful and offenders may be prosecuted to the fullest extent of the law. Unless otherwise stated the results shown in this test report refer only to the sample(s) tested and such sample(s) are retained for 90 days only

6.10 Conducted Spurious Emissions and Band-edge

Test Configuration:

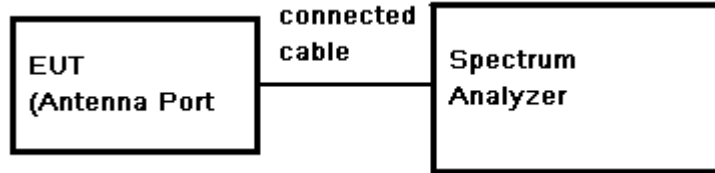

Test Procedure:

1. Remove the antenna from the EUT and then connect a low RF cable from the antenna port to the spectrum.
2. Set the spectrum analyzer: RBW = 100KHz. VBW >= RBW. Sweep = auto; Detector Function = Peak (Max. hold).

Limit:

(d) In any 100 kHz bandwidth outside the frequency band in which the spread spectrum or digitally modulated intentional radiator is operating. The radio frequency power that is produced by the intentional radiator shall be at least 20 dB below that in the 100 kHz bandwidth within the band that contains the highest level of the desired power. Based on either an RF conducted or a radiated measurement. Provided the transmitter demonstrates compliance with the peak conducted power limits.

Test Result:

Pass

6.10.1 Conducted spurious emission

Test plot as follows:

Test mode	Channel Low
-----------	-------------

30MHz-3GHz:

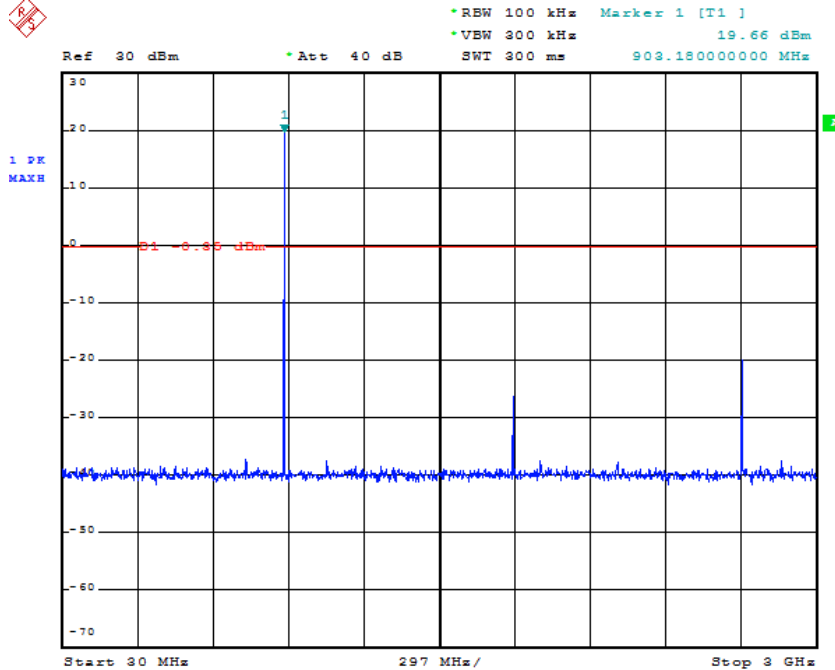

3GHz-25GHz:

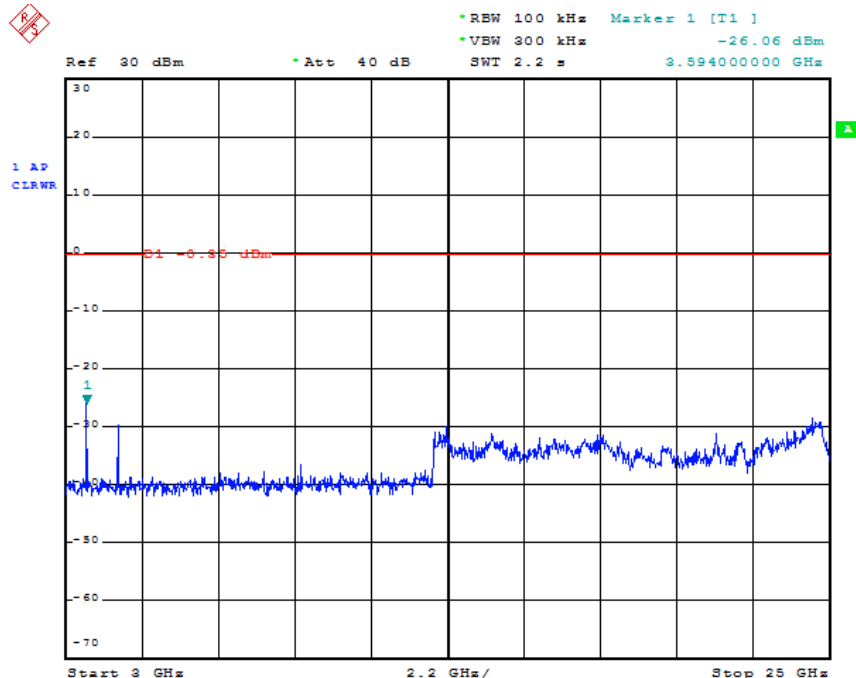

Test mode	Channel Middle
-----------	----------------

30MHz-3GHz:

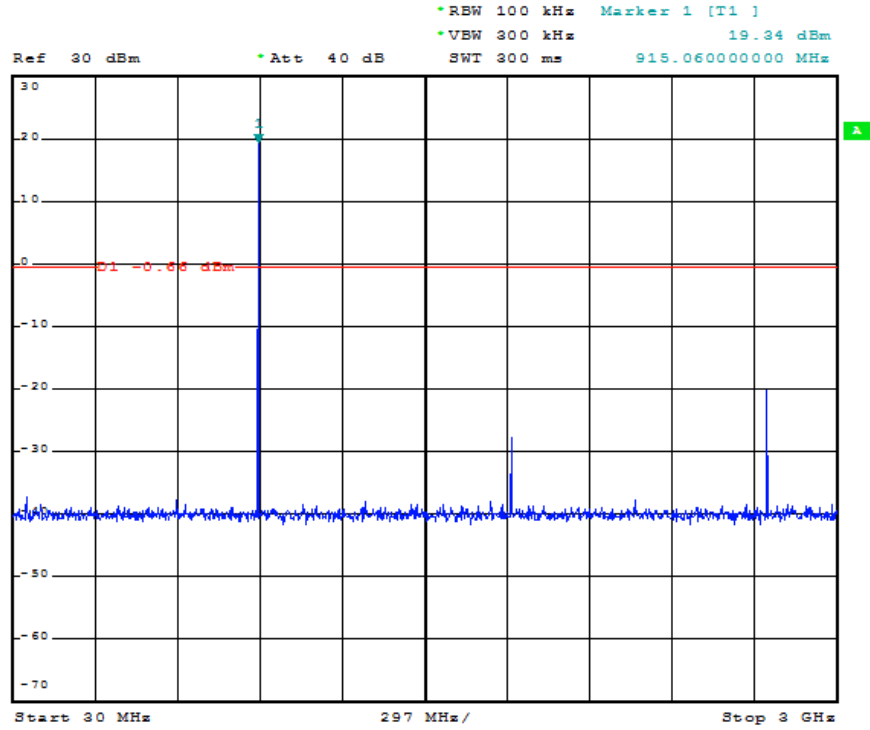

3GHz-25GHz:

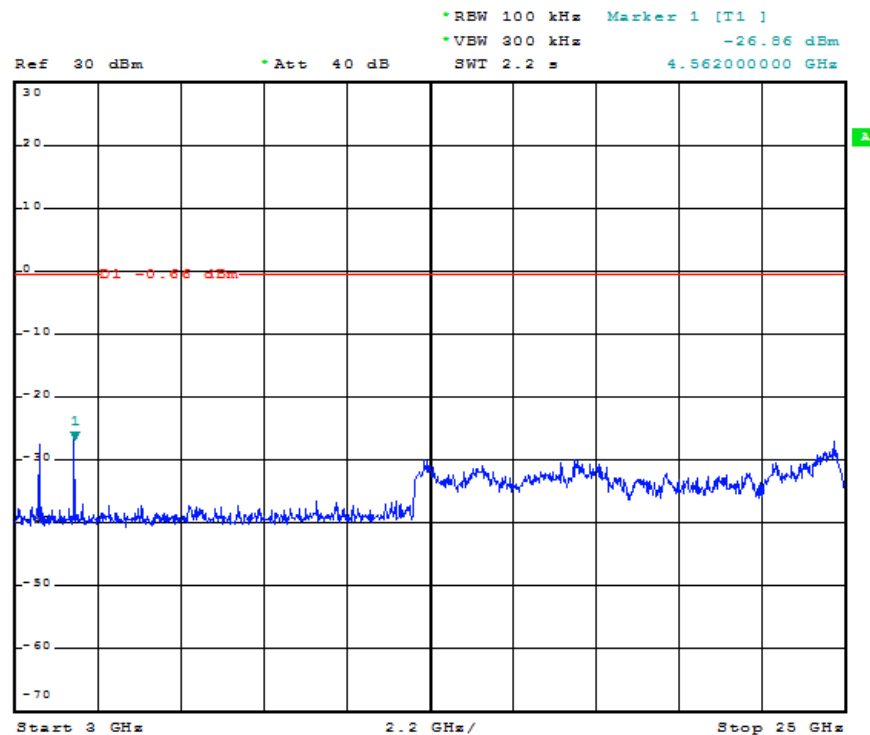

Test mode	Channel High
-----------	--------------

30MHz-3GHz:

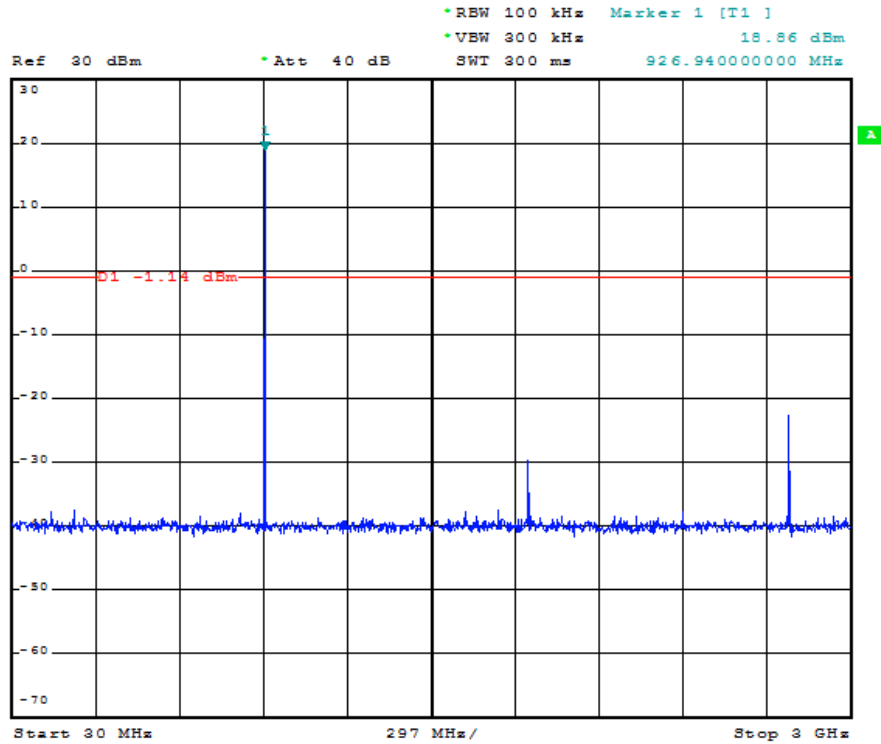

3GHz-25GHz:

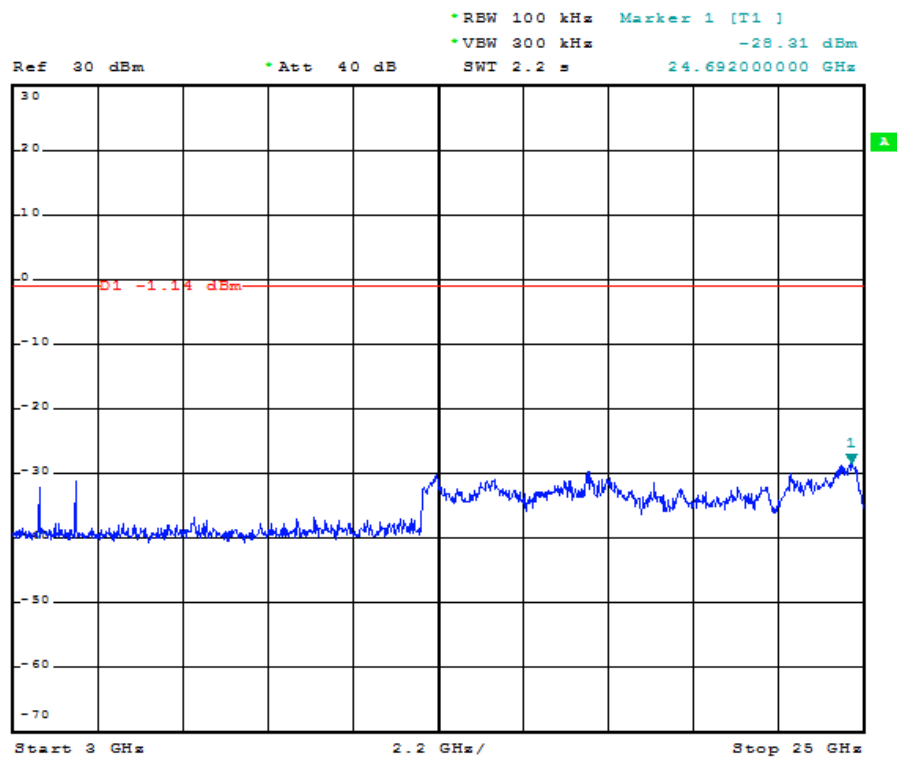

This document is issued by the Company subject to its General Conditions of Service printed overleaf, available on request or accessible at www.sgs.com/terms_and_conditions.htm and, for electronic format documents, subject to Terms and Conditions for Electronic Documents at www.sgs.com/terms_e-document.htm. Attention is drawn to the limitation of liability, indemnification and jurisdiction issues defined therein. Any holder of this document is advised that information contained hereon reflects the Company's findings at the time of its intervention only and within the limits of Client's instructions, if any. The Company's sole responsibility is to its Client and this document does not exonerate parties to a transaction from exercising all their rights and obligations under the transaction documents. This document cannot be reproduced except in full, without prior written approval of the Company. Any unauthorized alteration, forgery or falsification of the content or appearance of this document is unlawful and offenders may be prosecuted to the fullest extent of the law. Unless otherwise stated the results shown in this test report refer only to the sample(s) tested and such sample(s) are retained for 90 days only

6.11 Radiated Spurious Emissions and Band-edge

Frequency Range: 9KHz to 25GHz

Test site/setup: Measurement Distance: 3m (Semi-Anechoic Chamber)

Test instrumentation set-up:

Frequency Range	Detector	RBW	VBW
0.009MHz-0.090MHz	Peak	10kHz	30kHz
0.009MHz-0.090MHz	Average	10kHz	30kHz
0.090MHz-0.110MHz	Quasi-peak	10kHz	30kHz
0.110MHz-0.490MHz	Peak	10kHz	30kHz
0.110MHz-0.490MHz	Average	10kHz	30kHz
0.490MHz -30MHz	Quasi-peak	10kHz	30kHz
30MHz-1GHz	Quasi-peak	100kHz	300kHz
Above 1GHz	Peak	RBW=1MHz	VBW≥RBW
	Average		VBW=10Hz

Sweep=Auto

15.209 Limit:

Frequency	Limit (dBuV/m)
0.009MHz-0.490MHz	128.5 ~ 93.8
0.490MHz-1.705MHz	73.8 ~63.0
1.705MHz-30MHz	69.5
30MHz-88MHz	40.0
88MHz-216MHz	43.5
216MHz-960MHz	46.0
960MHz-1GHz	54.0
Above 1GHz	54.0

Note: 15.35(b), Unless otherwise specified, the limit on peak radio frequency emissions is 20dB above the maximum permitted average emission limit applicable to the equipment under test. This peak limit applies to the total peak emission level radiated by the device.

Test Configuration: Receive antenna scan height 1 m - 4 m. polarization Vertical / Horizontal

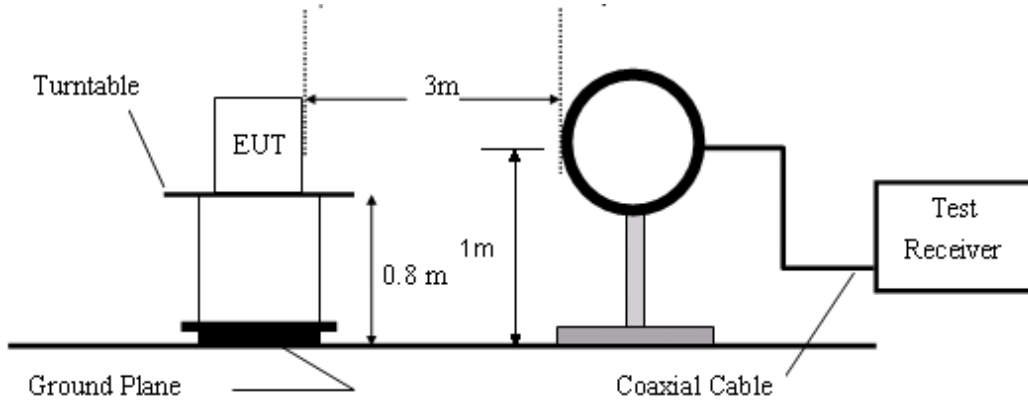

Figure1. Below 30MHz radiated emissions test configuration

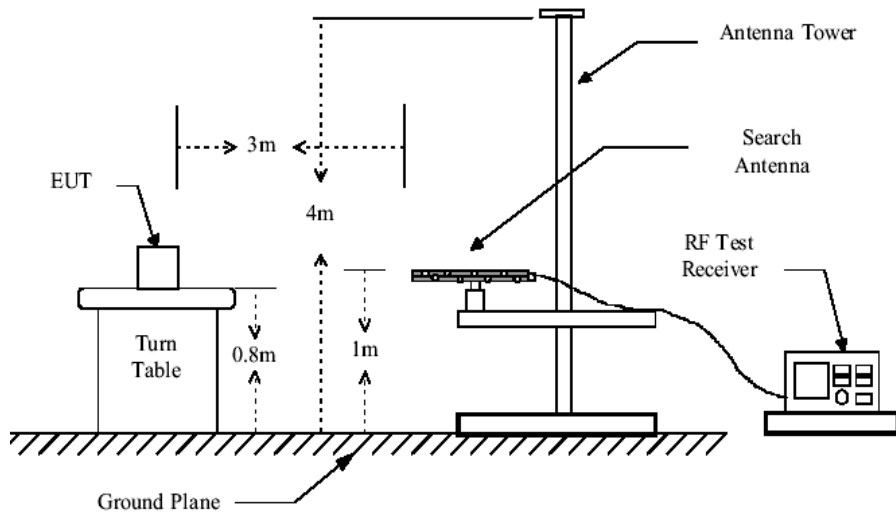

Figure2. 30MHz to 1GHz radiated emissions test configuration

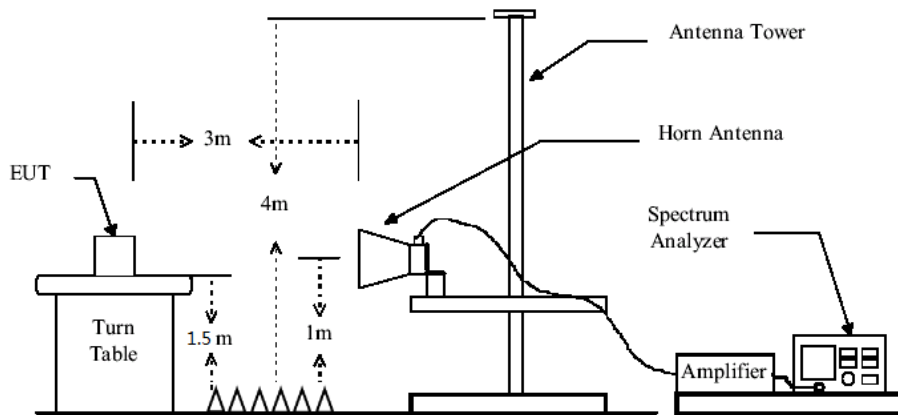

Figure3. Above 1GHz radiated emissions test configuration

Test Procedure:

- 1) The procedure used was ANSI Standard C63.10. The receiver was scanned from 9KHz to 25GHz. When an emission was found, the table was rotated to produce the maximum signal strength. An initial pre-scan was performed for in peak detection mode using the receiver. The EUT was measured for both the Horizontal and Vertical polarities and performed a pre-test three orthogonal planes. For intentional radiators, measurements of the variation of the input power or the radiated signal level of the fundamental frequency component of the emission, as appropriate, shall be performed with the supply voltage varied between 85% and 115% of the nominal rated supply voltage. The worst case emissions were reported.
- 2) Low noise amplifier was used below 1GHz, High pass Filter was used above 3GHz. Between 1G and 3GHz, we did not use any amplifier or filter.
- 3) Pre-test was performed on all modes, Compliance test was performed on worse case (GFSK mode).
 - a) Below 30 MHz, Test were performed for their spatial orthogonal(X, Y, Z), the worst test data (X orthogonal) was submitted.
 - b) For this intentional radiator operates below 25 GHz. the spectrum shall be investigated to the tenth harmonic of the highest fundamental frequency. And above the third harmonic of this intentional radiator, the disturbance is very low. So the test result only displays to 5rd harmonic.
 - c) As shown in Section, for frequencies above 1000MHz. the above field strength limits are based on average limits. However, the peak field strength of any emission shall not exceed the maximum permitted average limits specified above by more than 20 dB under any condition of modulation.
- 4) No spurious emissions were detected within 20dB of limit below 30MHz.

Test Result:

Pass

6.11.1 Radiated Spurious Emissions

30MHz-1GHz:

Channel Low

Item	Freq.	Read Level	Antenna Factor	Preamp Factor	Cable Loss	Result Level	Limit Line	Over Limit	Detector	Polarization
(Mark)	(MHz)	(dB μ V)	(dB/m)	(dB)	(dB)	(dB μ V/m)	(dB μ V/m)	(dB)		
1	107.89	56.41	10.54	28.60	1.31	39.66	43.50	-3.84	QP	VERTICAL
2	114.11	54.56	11.27	28.60	1.30	38.53	43.50	-4.97	QP	VERTICAL
3	845.09	45.01	23.60	29.04	3.93	43.50	46.00	-2.50	QP	VERTICAL
4*	903.31	117.26	22.96	28.94	4.12	115.40	46.00	69.40	QP	VERTICAL
1	642.86	45.88	20.33	29.27	3.38	40.32	46.00	-5.68	QP	HORIZONTAL
2	709.18	45.34	21.03	29.29	3.60	40.68	46.00	-5.32	QP	HORIZONTAL
3	787.85	45.37	23.32	29.13	3.83	43.39	46.00	-2.61	QP	HORIZONTAL
4*	903.31	103.57	22.96	28.94	4.12	101.71	46.00	55.71	QP	HORIZONTAL

Channel Middle

Item	Freq.	Read Level	Antenna Factor	Preamp Factor	Cable Loss	Result Level	Limit Line	Over Limit	Detector	Polarization
(Mark)	(MHz)	(dB μ V)	(dB/m)	(dB)	(dB)	(dB μ V/m)	(dB μ V/m)	(dB)		
1	107.89	56.84	10.54	28.60	1.31	40.09	43.50	-3.41	QP	VERTICAL
2	114.11	55.89	11.27	28.60	1.30	39.86	43.50	-3.64	QP	VERTICAL
3	857.03	44.47	23.44	29.02	3.96	42.85	46.00	-3.15	QP	VERTICAL
4*	916.07	115.26	23.31	28.92	4.13	113.78	46.00	67.78	QP	VERTICAL
1	605.66	45.26	20.20	29.25	3.29	39.50	46.00	-6.50	QP	HORIZONTAL
2	719.20	45.07	21.17	29.30	3.61	40.55	46.00	-5.45	QP	HORIZONTAL
3	796.18	45.15	23.45	29.11	3.83	43.32	46.00	-2.68	QP	HORIZONTAL
4*	903.31	103.58	22.96	28.94	4.12	101.72	46.00	55.72	QP	HORIZONTAL

Channel High

Item	Freq.	Read Level	Antenna Factor	Preamp Factor	Cable Loss	Result Level	Limit Line	Over Limit	Detector	Polarization
(Mark)	(MHz)	(dB μ V)	(dB/m)	(dB)	(dB)	(dB μ V/m)	(dB μ V/m)	(dB)		
1	107.89	56.74	10.54	28.60	1.31	39.99	43.50	-3.51	QP	VERTICAL
2	114.11	55.73	11.27	28.60	1.30	39.70	43.50	-3.80	QP	VERTICAL
3	830.40	44.39	23.80	29.06	3.92	43.05	46.00	-2.95	QP	VERTICAL

This document is issued by the Company subject to its General Conditions of Service printed overleaf, available on request or accessible at www.sgs.com/terms_and_conditions.htm and, for electronic format documents, subject to Terms and Conditions for Electronic Documents at www.sgs.com/terms_e-document.htm. Attention is drawn to the limitation of liability, indemnification and jurisdiction issues defined therein. Any holder of this document is advised that information contained hereon reflects the Company's findings at the time of its intervention only and within the limits of Client's instructions, if any. The Company's sole responsibility is to its Client and this document does not exonerate parties to a transaction from exercising all their rights and obligations under the transaction documents. This document cannot be reproduced except in full, without prior written approval of the Company. Any unauthorized alteration, forgery or falsification of the content or appearance of this document is unlawful and offenders may be prosecuted to the fullest extent of the law. Unless otherwise stated the results shown in this test report refer only to the sample(s) tested and such sample(s) are retained for 90 days only

4*	929.01	114.05	23.40	28.89	4.15	112.71	46.00	66.71	QP	VERTICAL
1	687.15	45.40	20.15	29.28	3.57	39.84	46.00	-6.16	QP	HORIZONTAL
2	793.40	44.82	23.41	29.12	3.83	42.94	46.00	-3.06	QP	HORIZONTAL
3	830.40	44.83	23.80	29.06	3.92	43.49	46.00	-2.51	QP	HORIZONTAL
4*	929.01	93.87	23.40	28.89	4.15	92.53	46.00	46.53	QP	HORIZONTAL

*: Operating frequency
Above 1GHz:

Lowest Channel

Mark	Frequency (MHz)	Reading (dBuV)	Factor (dB)	Emission (dBuV/m)	Limit (dBuV/m)	Over Limit (dB)	Detector	Polarization
1	1805	55.14	-4.51	50.63	54	-3.37	peak	Horizontal
2	2707.5	54.32	-1.96	52.36	54	-1.64	peak	Horizontal
3	3610	42.87	2.57	45.44	54	-8.56	peak	Horizontal
4	1805	54.12	-4.51	49.61	54	-4.39	peak	Vertical
5	2707.5	54.07	-1.96	52.11	54	-1.89	peak	Vertical
6	3610	48.66	2.57	51.23	54	-2.77	peak	Vertical

Middle Channel

Mark	Frequency (MHz)	Reading (dBuV)	Factor (dB)	Emission (dBuV/m)	Limit (dBuV/m)	Over Limit (dB)	Detector	Polarization
1	1830	53.47	-4.37	49.1	54	-4.9	peak	Horizontal
2	2745	53.81	-1.64	52.17	54	-1.83	peak	Horizontal
3	3660	42.65	2.59	45.24	54	-8.76	peak	Horizontal
4	1830	54.36	-4.37	49.99	54	-4.01	peak	Vertical
5	2745	54.83	-1.64	53.19	54	-0.81	peak	Vertical
6	3660	46.51	2.59	49.1	54	-4.9	peak	Vertical

Highest Channel

Mark	Frequency (MHz)	Reading (dBuV)	Factor (dB)	Emission (dBuV/m)	Limit (dBuV/m)	Over Limit (dB)	Detector	Polarization
1	1854	52.78	-4.24	48.54	54	-5.46	peak	Horizontal
2	2781	54.02	-1.33	52.69	54	-1.31	peak	Horizontal
3	3708	43.93	2.65	46.58	54	-7.42	peak	Horizontal
4	1854	54.87	-4.24	50.63	54	-3.37	peak	Vertical
5	2781	54.77	-1.33	53.44	54	-0.56	peak	Vertical
6	3708	46.18	2.65	48.83	54	-5.17	peak	Vertical

- Remark: 1) Emission = Receiver Reading + Factor
 2) Factor = Antenna Factor + Cable Loss + Pre-amplifier Factor.
 3) If the Peak value below the AV Limit, the AV test doesn't perform for this submission.

This document is issued by the Company subject to its General Conditions of Service printed overleaf, available on request or accessible at www.sgs.com/terms_and_conditions.htm and, for electronic format documents, subject to Terms and Conditions for Electronic Documents at www.sgs.com/terms_e-document.htm. Attention is drawn to the limitation of liability, indemnification and jurisdiction issues defined therein. Any holder of this document is advised that information contained hereon reflects the Company's findings at the time of its intervention only and within the limits of Client's instructions, if any. The Company's sole responsibility is to its Client and this document does not exonerate parties to a transaction from exercising all their rights and obligations under the transaction documents. This document cannot be reproduced except in full, without prior written approval of the Company. Any unauthorized alteration, forgery or falsification of the content or appearance of this document is unlawful and offenders may be prosecuted to the fullest extent of the law. Unless otherwise stated the results shown in this test report refer only to the sample(s) tested and such sample(s) are retained for 90 days only

6.11.2 Radiated Band edge Lowest Channel

Vertical:

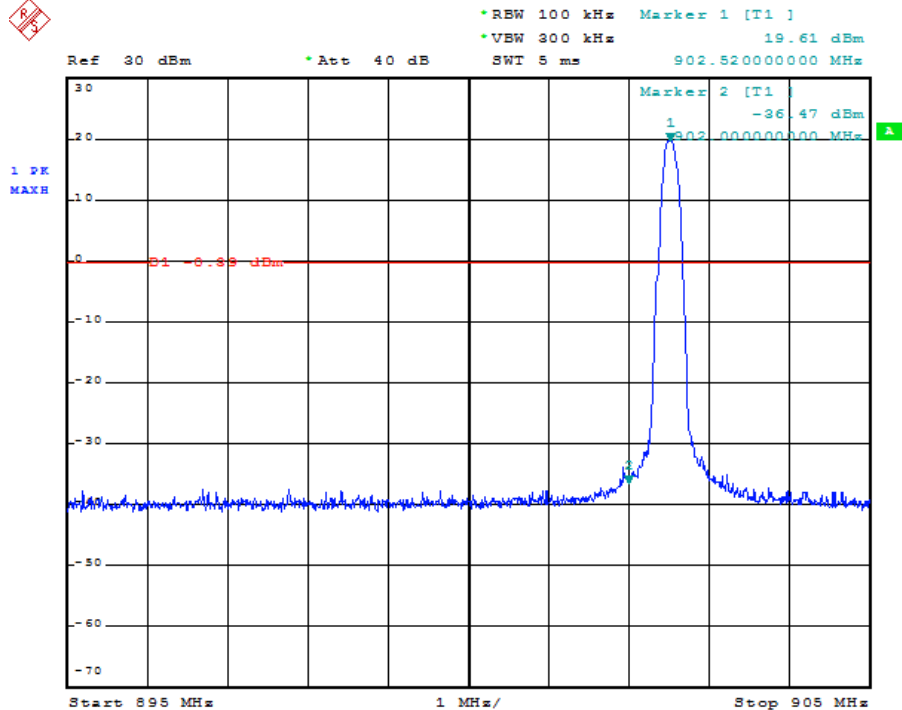

Horizontal:

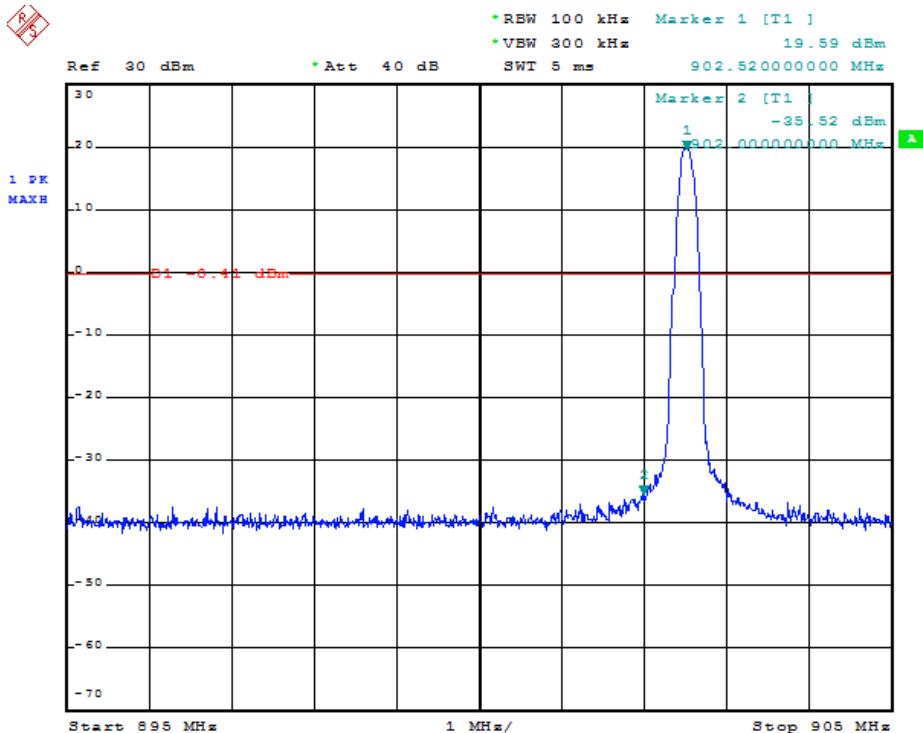

Highest Channel

Vertical:

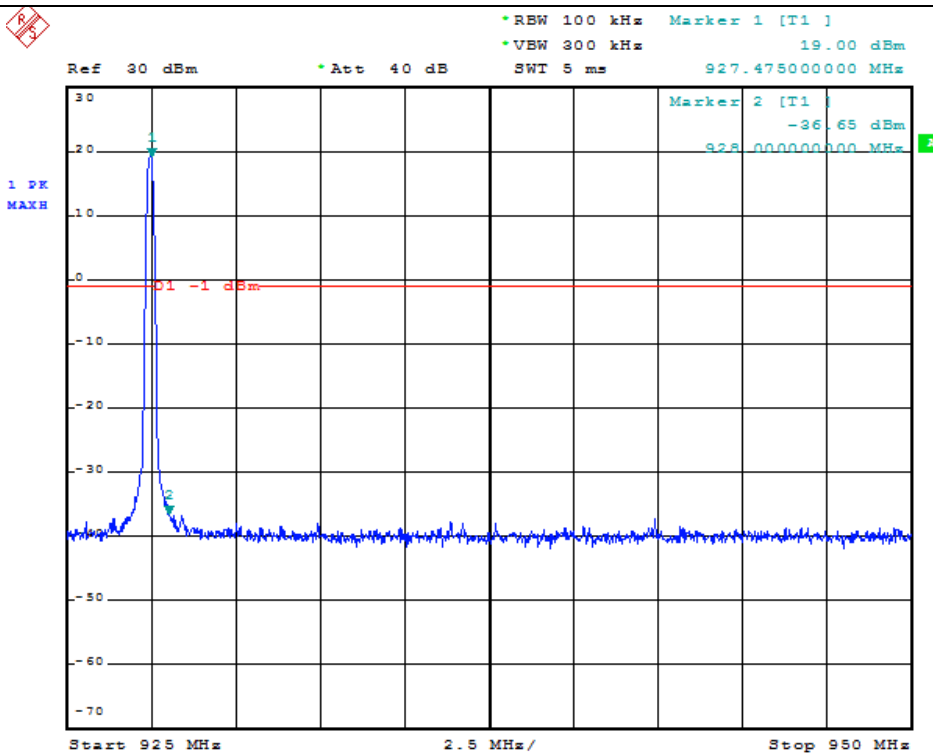

Horizontal:

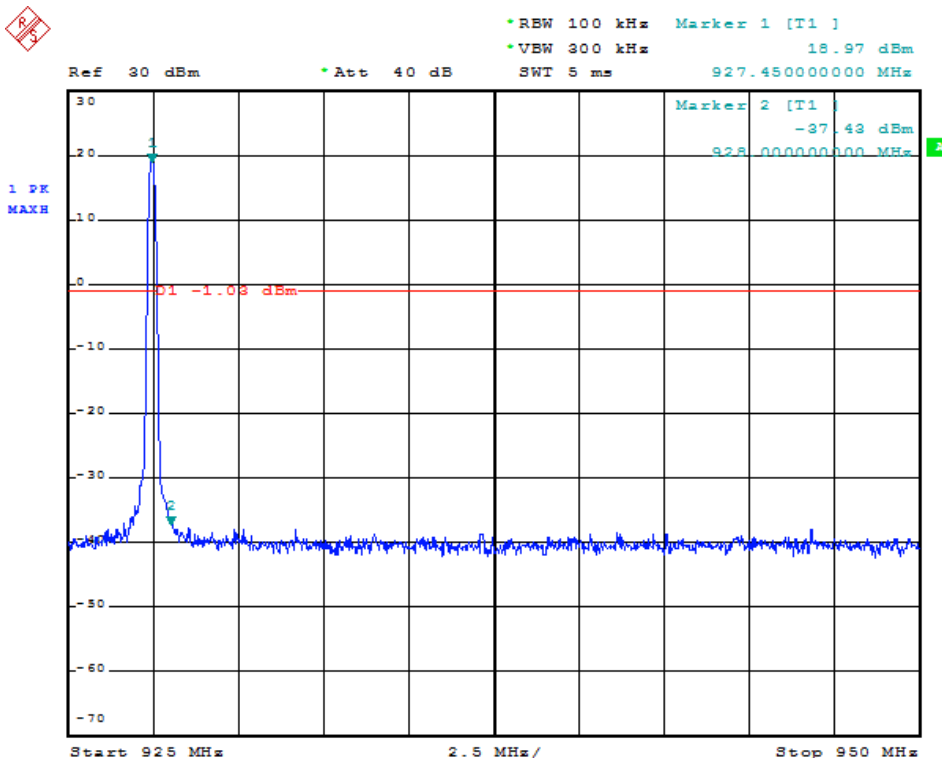



All frequencies within the “Restricted bands” have been evaluated to compliance. Except as shown in paragraph of this section, only spurious emissions are permitted in any of the frequency bands listed below:

a. FCC Part 15, Subpart C Section 15.205 Restricted bands of operation.

MHz	MHz	MHz	GHz
0.090 - 0.110	16.42 - 16.423	399.9 - 410	4.5 - 5.15
¹ 0.495 - 0.505	16.69475 - 16.69525	608 - 614	5.35 - 5.46
2.1735 - 2.1905	16.80425 - 16.80475	960 - 1240	7.25 - 7.75
4.125 - 4.128	25.5 - 25.67	1300 - 1427	8.025 - 8.5
4.17725 - 4.17775	37.5 - 38.25	1435 - 1626.5	9.0 - 9.2
4.20725 - 4.20775	73 - 74.6	1645.5 - 1646.5	9.3 - 9.5
6.215 - 6.218	74.8 - 75.2	1660 - 1710	10.5 - 12.7
6.26775 - 6.26825	108 - 121.94	1718.8 - 1722.2	13.25 - 13.4
6.31175 - 6.31225	123 - 138	2200 - 2300	14.47 - 14.5
8.291 - 8.294	149.9 - 150.05	2310 - 2390	15.35 - 16.2
8.362 - 8.366	156.52475 - 156.52525	2483.5 - 2500	17.7 - 21.4
8.37625 - 8.38675	156.7 - 156.9	2655 - 2900	22.01 - 23.12
8.41425 - 8.41475	162.0125 - 167.17	3260 - 3267	23.6 - 24.0
12.29 - 12.293	167.72 - 173.2	3332 - 3339	31.2 - 31.8
12.51975 - 12.52025	240 - 285	3345.8 - 3358	36.43 - 36.5
12.57675 - 12.57725	322 - 335.4	3600 - 4400	
13.36 - 13.41			

7 Test Setup Photographs

Refer to the < Mag7 _Test Setup photos-FCC>.

8 EUT Constructional Details

Refer to the < Mag7 _External Photos > & < Mag7 _Internal Photos>.

--End of the Report--