SAR Test Report

Report No.: AGC00594170602FH01

FCC ID : 2AI3K-CS24SA
APPLICATION PURPOSE : Original Equipment
PRODUCT DESIGNATION : Rugged Mobile Phone
BRAND NAME : Cyrus
MODEL NAME : CS24SA
CLIENT : Cyrus Technology GmbH
DATE OF ISSUE : July 12,2017
STANDARD(S) : IEEE Std. 1528:2013
: FCC 47CFR § 2.1093
: IEEE/ANSI C95.1:2005
REPORT VERSION : V1.0

Attestation of Global Compliance (Shenzhen) Co., Ltd.

CAUTION:

This report shall not be reproduced except in full without the written permission of the test laboratory and shall not be quoted out of context.



Report Revise Record

Report Version	Revise Time	Issued Date	Valid Version	Notes
V1.0	/	July 12,2017	Valid	Original Report

Test Report Certification

Applicant Name	Cyrus Technology GmbH
Applicant Address	Hergelsbendenstraße 49 D-52080 Aachen Germany
Manufacturer Name	Shenzhen Xin Kingbrand Enterprises Co., Ltd.
Manufacturer Address	KingBrand Industrial Zone, Nanpu Road, Shang Liao Lin Pikeng, Shajing Town, Baoan District, Shenzhen City, Guangdong Province, China
Product Designation	Rugged Mobile Phone
Brand Name	Cyrus
Model Name	CS24SA
Different Description	N/A
EUT Voltage	DC3.8V by battery
Applicable Standard	IEEE Std. 1528:2013 FCC 47CFR § 2.1093 IEEE/ANSI C95.1:2005
Test Date	June 28, 2017 to July 12,2017
Performed Location	Attestation of Global Compliance(Shenzhen) Co., Ltd. 2 F, Building 2, No.1-No.4, Chaxi Sanwei Technical Industrial Park, Gushu, Xixiang Street, Bao'an District, Shenzhen, China
Report Template	AGCRT-US-4G/SAR (2016-01-01)

Eric Zhou

Tested By _____

Eric Zhou(Zhou Yongkang) July 12,2017

Angela Li

Checked By _____

Angela Li(Li Jiao) July 12,2017

Forrest Lei

Authorized By _____

Forrest Lei(Lei Yonggang)
Authorized Officer July 12,2017

TABLE OF CONTENTS

1. SUMMARY OF MAXIMUM SAR VALUE	5
2. GENERAL INFORMATION.....	6
2.1. EUT DESCRIPTION.....	6
3. SAR MEASUREMENT SYSTEM.....	8
3.1. THE SATIMO SYSTEM USED FOR PERFORMING COMPLIANCE TESTS CONSISTS OF FOLLOWING ITEMS	8
3.2. COMOSAR E-FIELD PROBE	9
3.3. ROBOT.....	10
3.4. VIDEO POSITIONING SYSTEM	10
3.5. DEVICE HOLDER.....	11
3.6. SAM TWIN PHANTOM.....	11
4. SAR MEASUREMENT PROCEDURE.....	12
4.1. SPECIFIC ABSORPTION RATE (SAR).....	12
4.2. SAR MEASUREMENT PROCEDURE	13
4.3. RF EXPOSURE CONDITIONS	15
5. TISSUE SIMULATING LIQUID.....	17
5.1. THE COMPOSITION OF THE TISSUE SIMULATING LIQUID.....	17
5.2. TISSUE DIELECTRIC PARAMETERS FOR HEAD AND BODY PHANTOMS	18
5.3. TISSUE CALIBRATION RESULT	19
6. SAR SYSTEM CHECK PROCEDURE	22
6.1. SAR SYSTEM CHECK PROCEDURES	22
6.2. SAR SYSTEM CHECK.....	23
7. EUT TEST POSITION.....	25
7.1. DEFINE TWO IMAGINARY LINES ON THE HANDSET.....	25
7.2. CHEEK POSITION	26
7.3. TILT POSITION.....	26
7.4. BODY WORN POSITION	27
8. SAR EXPOSURE LIMITS	28
9. TEST EQUIPMENT LIST	29
10. MEASUREMENT UNCERTAINTY	30
11. CONDUCTED POWER MEASUREMENT.....	31
12. TEST RESULTS	55
12.1. SAR TEST RESULTS SUMMARY.....	55
APPENDIX A. SAR SYSTEM CHECK DATA	78
APPENDIX B. SAR MEASUREMENT DATA.....	102
APPENDIX C. TEST SETUP PHOTOGRAPHS.....	166
APPENDIX D. CALIBRATION DATA	173

1. SUMMARY OF MAXIMUM SAR VALUE

The maximum results of Specific Absorption Rate (SAR) found during testing for EUT are as follows:

Frequency Band	Highest Reported 1g-SAR(W/Kg)		SAR Test Limit (W/Kg)
	Head	Body-worn	
GSM 850	0.477	0.774	1.6
PCS 1900	0.677	1.043	
UMTS Band II	0.500	1.144	
UMTS Band IV	0.175	0.435	
UMTS Band V	0.254	0.513	
LTE Band 2	0.337	0.793	
LTE Band 4	0.209	0.499	
LTE Band 5	0.486	0.768	
LTE Band 7	0.404	0.799	
LTE Band 17	0.064	0.162	
WIFI 2.4G	0.655	0.421	
Simultaneous Reported SAR	1.565		
SAR Test Result	PASS		

This device is compliance with Specific Absorption Rate (SAR) for general population/uncontrolled exposure limits (1.6W/Kg) specified in IEEE Std. 1528:2013; FCC 47CFR § 2.1093; IEEE/ANSI C95.1:2005 and the following specific FCC Test Procedures:

- KDB 447498 D01 General RF Exposure Guidance v06
- KDB 648474 D04 Handset SAR v01r03
- KDB 865664 D01 SAR Measurement 100MHz to 6GHz v01r04
- KDB 941225 D01 3G SAR Procedures v03r01
- KDB 941225 D06 Hotspot Mode v02r01
- KDB 248227 D01 802 11 Wi-Fi SAR v02r02
- KDB 941225 D05 SAR for LTE Devices v02r05

2. GENERAL INFORMATION

2.1. EUT Description

General Information	
Product Designation	Rugged Mobile Phone
Test Model	CS24SA
Hardware Version	FQ5_02
Software Version	V18N_smartphone_20170608_V1.04
Device Category	Portable
RF Exposure Environment	Uncontrolled
Antenna Type	Internal
GSM and GPRS& EGPRS	
Support Band	<input checked="" type="checkbox"/> GSM 850 <input checked="" type="checkbox"/> PCS 1900 <input checked="" type="checkbox"/> GSM 900 <input checked="" type="checkbox"/> DCS 1800
GPRS & EGPRS Type	Class B
GPRS & EGPRS Class	Class 12(1Tx+4Rx, 2Tx+3Rx, 3Tx+2Rx, 4Tx+1Rx)
TX Frequency Range	GSM 850 : 820-850MHz; PCS 1900: 1850-1910MHz;
RX Frequency Range	GSM 850 : 869~894MHz; PCS 1900: 1930~1990MHz
Release Version	R99
Type of modulation	GMSK for GSM/GPRS; GMSK & 8-PSK for EGPRS
Antenna Gain	GSM850: -0.7dBi; PCS1900: -1.1dBi;
Max. Average Power	GSM850: 31.93dBm; PCS1900: 27.63dBm
WCDMA	
Support Band	<input checked="" type="checkbox"/> UMTS FDD Band II <input checked="" type="checkbox"/> UMTS FDD Band V <input checked="" type="checkbox"/> UMTS FDD Band IV <input type="checkbox"/> UMTS FDD Band I <input type="checkbox"/> UMTS FDD Band III <input type="checkbox"/> UMTS FDD Band VIII
HS Type	HSPA(HSUPA/HSDPA)
TX Frequency Range	FDD Band II: 1850-1910MHz; FDD Band V: 820-850MHz Band IV: 1712.4-1752.6MHz
RX Frequency Range	FDD Band II: 1930-1990MHz; FDD Band V: 869-894MHz Band IV: 2112.4-5152.6MHz
Release Version	Rel-6
Type of modulation	HSDPA:QPSK/16QAM; HSUPA:BPSK; WCDMA:QPSK
Antenna Gain	Band II: -1.1dBi; Band IV:-0.8 dBi ;Band V: -0.7dBi
Max. Average Power	Band II: 21.82dBm; Band IV: 20.77dBm; Band V: 20.74dBm

EUT Description(Continue)

LTE	
Support Band	<input checked="" type="checkbox"/> FDD Band 2 <input checked="" type="checkbox"/> FDD Band 4 <input checked="" type="checkbox"/> FDD Band 5 <input checked="" type="checkbox"/> FDD Band 7 <input type="checkbox"/> FDD Band 12 <input checked="" type="checkbox"/> FDD Band 17 <input type="checkbox"/> FDD Band 25 <input type="checkbox"/> FDD Band 26 <input checked="" type="checkbox"/> TDD Band 40 <input type="checkbox"/> TDD Band 41
TX Frequency Range	Band 2: 1850-1909.9MHz; Band 4: 1710 -1754.9MHz; Band 5 :824-849MHz; Band 7:2500-2570MHz; Band 17: 704-716 MHz;
RX Frequency Range	Band 2: 1930-1989.9 MHz; Band 4: 2110 -2154.9MHz; Band 5 :869-894MHz; Band 7:2620-2690MHz ;Band 17 734-746 MHz;
Release Version	Rel-8
Type of modulation	QPSK, 16QAM
Antenna gain:	-1.1dBi(LTE band 2),-0.8dBi(LTE band 4), -0.7dBi(LTE band 5), -0.2dBi(LTE band 7), -1.0dBi(LTE band 17)
Diversity Antenna Gain	-1.2dBi(LTE band 2),-1.0dBi(LTE band 4), -0.8dBi(LTE band 5), -0.4dBi(LTE band 7), -1.1dBi(LTE band 17)
Max. Average Power	Band 2: 22.92dBm; Band 4: 22.93dBm; Band 5: 22.92dBm Band 7: 22.94dBm; Band 17: 22.94dBm
Bluetooth	
Bluetooth Version	<input type="checkbox"/> V2.0 <input type="checkbox"/> V2.1 <input type="checkbox"/> V2.1+EDR <input checked="" type="checkbox"/> V3.0 <input type="checkbox"/> V3.0+HS <input checked="" type="checkbox"/> V4.0 <input type="checkbox"/> V4.1
Operation Frequency	2402~2480MHz
Type of modulation	<input checked="" type="checkbox"/> GFSK <input checked="" type="checkbox"/> II/4-DQPSK <input checked="" type="checkbox"/> 8-DPSK
Peak Power	1.133dBm
Antenna Gain	0.6dBi
WIFI	
WIFI Specification	<input type="checkbox"/> 802.11a <input checked="" type="checkbox"/> 802.11b <input checked="" type="checkbox"/> 802.11g <input checked="" type="checkbox"/> 802.11n(20) <input checked="" type="checkbox"/> 802.11n(40)
Operation Frequency	2412~2472MHz
Avg. Burst Power	11b: 12.59dBm,11g:10.62dBm,11n(20): 10.55dBm,11n(40): 10.32dBm
Antenna Gain	0.6dBi
Accessories	
Battery	Brand name: N/A Model No. : V18H Voltage and Capacitance: 3.8 V & 5000mAh
Adapter	Brand name: N/A Model No. : TPA – 10120125UU-MTK Input AC 100-240V 50/60HZ ,Output DC 5V 2A/7V 1.67A/9V 1.67A/12V 1.25A
Earphone	Brand name: N/A Model No. : N/A
Note:1.CMU200 can measure the average power and Peak power at the same time 2.The sample used for testing is end product.	
Product	Type <input checked="" type="checkbox"/> Production unit <input type="checkbox"/> Identical Prototype

3. SAR MEASUREMENT SYSTEM

3.1. The SATIMO system used for performing compliance tests consists of following items

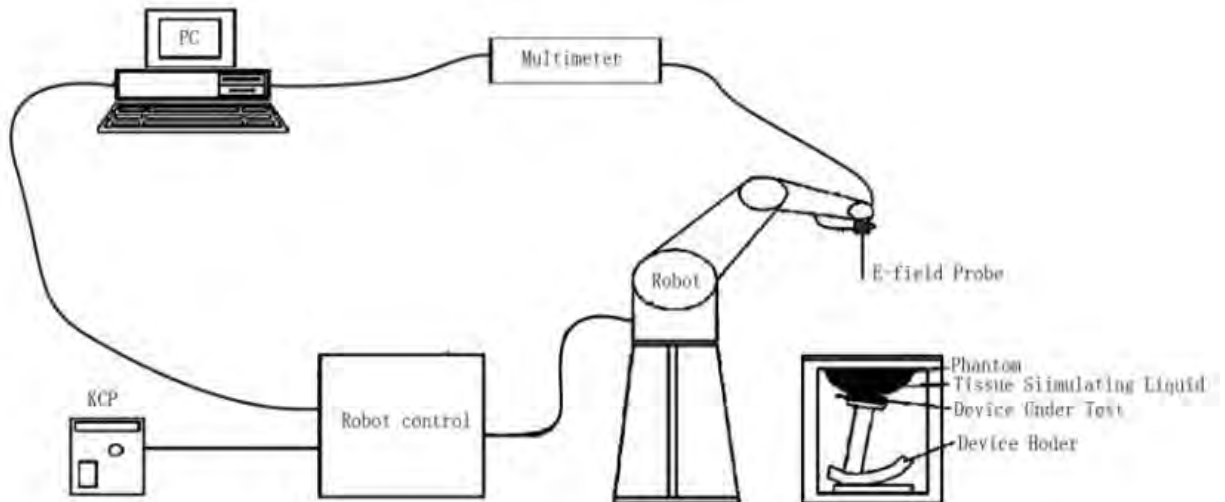

The COMOSAR system for performing compliance tests consists of the following items:

- The PC. It controls most of the bench devices and stores measurement data. A computer running WinXP and the Opensar software.
- The E-Field probe. The probe is a 3-axis system made of 3 distinct dipoles. Each dipole returns a voltage in function of the ambient electric field.
- The Keithley multimeter measures each probe dipole voltages.
- The SAM phantom simulates a human head. The measurement of the electric field is made inside the phantom.
- The liquids simulate the dielectric properties of the human head tissues.
- The network emulator controls the mobile phone under test.
- The validation dipoles are used to measure a reference SAR. They are used to periodically check the bench to make sure that there is no drift of the system characteristics over time.
- The phantom, the device holder and other accessories according to the targeted measurement.

3.2. COMOSAR E-Field Probe

The SAR measurement is conducted with the dosimetric probe manufactured by SATIMO. The probe is specially designed and calibrated for use in liquid with high permittivity. The dosimetric probe has special calibration in liquid at different frequency. SATIMO conducts the probe calibration in compliance with international and national standards (e.g. IEEE 1528 and relevant KDB files.) The calibration data are in Appendix D.

Isotropic E-Field Probe Specification

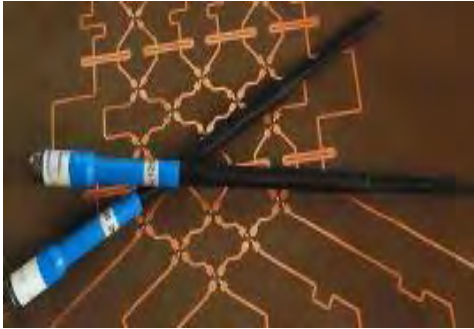
Model	SSE5	
Manufacture	MVG	
Identification No.	SN 14/16 EP308	
Frequency	0.3GHz-3.7GHz Linearity:±0.08dB(300MHz -3.7GHz)	
Dynamic Range	0.01W/Kg-100W/Kg Linearity:±0.08dB	
Dimensions	Overall length:330mm Length of individual dipoles:4.5mm Maximum external diameter:8mm Probe Tip external diameter:5mm Distance between dipoles/ probe extremity:2.7mm	
Application	High precision dosimetric measurements in any exposure scenario (e.g., very strong gradient fields). Only probe which enables compliance testing for frequencies up to 3 GHz with precision of better 30%.	

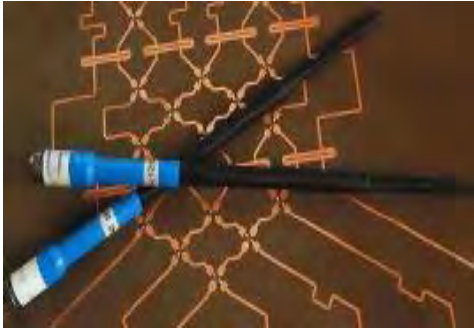
Model	SSE5	
Manufacture	MVG	
Identification No.	SN 14/16 EP307	
Frequency	0.7GHz-3GHz Linearity:±0.05dB(700MHz-3GHz)	
Dynamic Range	0.01W/Kg-100W/Kg Linearity:±0.05dB	
Dimensions	Overall length:330mm Length of individual dipoles:4.5mm Maximum external diameter:8mm Probe Tip external diameter:5mm Distance between dipoles/ probe extremity:2.7mm	
Application	High precision dosimetric measurements in any exposure scenario (e.g., very strong gradient fields). Only probe which enables compliance testing for frequencies up to 3 GHz with precision of better 30%.	

3.3. Robot

The COMOSAR system uses the KUKA robot from SATIMO SA (France). For the 6-axis controller COMOSAR system, the KUKA robot controller version from SATIMO is used.

The XL robot series have many features that are important for our application:

- High precision (repeatability 0.02 mm)
- High reliability (industrial design)
- Jerk-free straight movements
- Low ELF interference (the closed metallic construction shields against motor control fields)
- 6-axis controller



3.4. Video Positioning System

The video positioning system is used in OpenSAR to check the probe. Which is composed of a camera, LED, mirror and mechanical parts. The camera is piloted by the main computer with firewire link.

During the process, the actual position of the probe tip with respect to the robot arm is measured, as well as the probe length and the horizontal probe offset. The software then corrects all movements, such that the robot coordinates are valid for the probe tip.

The repeatability of this process is better than 0.1 mm. If a position has been taught with an aligned probe, the same position will be reached with another aligned probe within 0.1 mm, even if the other probe has different dimensions. During probe rotations, the probe tip will keep its actual position.

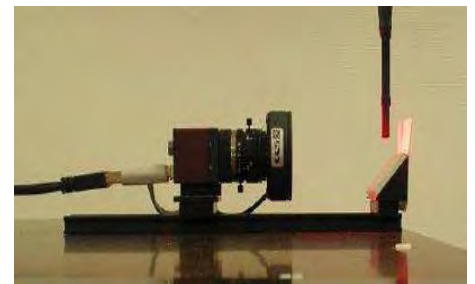

3.5. Device Holder

The COMOSAR device holder is designed to cope with different positions given in the standard. It has two scales for the device rotation (with respect to the body axis) and the device inclination (with respect to the line between the ear reference points). The rotation center for both scales is the ear reference point (EPR).

Thus the device needs no repositioning when changing the angles.

The COMOSAR device holder has been made out of low-loss POM material having the following dielectric parameters: relative permittivity

$\epsilon_r = 3$ and loss tangent $\delta = 0.02$. The amount of dielectric material has been reduced in the closest vicinity of the device, since measurements have suggested that the influence of the clamp on the test results could thus be lowered.

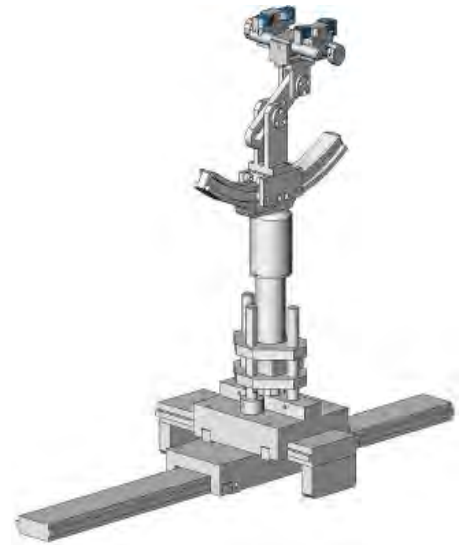

3.6. SAM Twin Phantom

The SAM twin phantom is a fiberglass shell phantom with 2mm shell thickness (except the ear region where shell thickness increases to 6mm). It has three measurement areas:

- Left head
- Right head
- Flat phantom



The bottom plate contains three pair of bolts for locking the device holder. The device holder positions are adjusted to the standard measurement positions in the three sections. A white cover is provided to tap the phantom during off-periods to prevent water evaporation and changes in the liquid parameters. On the phantom top, three reference markers are provided to identify the phantom position with respect to the robot.

4. SAR MEASUREMENT PROCEDURE

4.1. Specific Absorption Rate (SAR)

SAR is related to the rate at which energy is absorbed per unit mass in object exposed to a radio field. The SAR distribution in a biological body is complicated and is usually carried out by experimental techniques or numerical modeling. The standard recommends limits for two tiers of groups, occupational/controlled and occupational/uncontrolled, based on a person's awareness and ability to exercise control over his or her exposure. In general, occupational/controlled exposure limits are higher than the limits for general population/uncontrolled.

The SAR definition is the time derivative (rate) of the incremental energy (dW) absorbed by (dissipated in) an incremental mass (dm) contained in a volume element(dv) of given mass density (ρ). The equation description is as below:

$$SAR = \frac{d}{dt} \left(\frac{dW}{dm} \right) = \frac{d}{dt} \left(\frac{dW}{\rho dV} \right)$$

SAR is expressed in units of Watts per kilogram (W/Kg)

SAR can be obtained using either of the following equations:

$$SAR = \frac{\sigma E^2}{\rho}$$

$$SAR = c_h \left. \frac{dT}{dt} \right|_{t=0}$$

Where

SAR	is the specific absorption rate in watts per kilogram;
E	is the r.m.s. value of the electric field strength in the tissue in volts per meter;
ζ	is the conductivity of the tissue in siemens per metre;
ρ	is the density of the tissue in kilograms per cubic metre;
c _h	is the heat capacity of the tissue in joules per kilogram and Kelvin;

$\left. \frac{dT}{dt} \right|_{t=0}$ is the initial time derivative of temperature in the tissue in kelvins per second

4.2. SAR Measurement Procedure

Step 1: Power Reference Measurement

The Power Reference Measurement and Power Drift Measurement are for monitoring the power drift of the device under test in the batch process. The minimum distance of probe sensors to surface is 2.7mm This distance cannot be smaller than the distance os sensor calibration points to probe tip as `defined in the probe properties,

Step 2: Area Scan

The Area Scan is used as a fast scan in two dimensions to find the area of high field values, before doing a fine measurement around the hot spot. The sophisticated interpolation routines implemented in SATIMO software can find the maximum locations even in relatively coarse grids. When an Area Scan has measured all reachable points, it computes the field maximal found in the scanned area, within a range of the global maximum. The range (in db) is specified in the standards for compliance testing. For example, a 2db range is required in IEEE Standard 1528 and IEC62209 standards, whereby 3db is a requirement when compliance is assessed in accordance with the ARIB standard (Japan) If one Zoom Scan follows the Area Scan, then only the absolute maximum will be taken as reference. For cases where multiple maximum are detected, the number of Zoom Scan has to be increased accordingly.

Area Scan Parameters extracted from KDB 865664 D01 SAR Measurement 100MHz to 6GHz

	≤ 3 GHz	> 3 GHz
Maximum distance from closest measurement point (geometric center of probe sensors) to phantom surface	5 ± 1 mm	$\frac{1}{2} \cdot \delta \cdot \ln(2) \pm 0.5$ mm
Maximum probe angle from probe axis to phantom surface normal at the measurement location	30° ± 1°	20° ± 1°
Maximum area scan spatial resolution: Δx_{Area} , Δy_{Area}	≤ 2 GHz: ≤ 15 mm 2 – 3 GHz: ≤ 12 mm	3 – 4 GHz: ≤ 12 mm 4 – 6 GHz: ≤ 10 mm
	When the x or y dimension of the test device, in the measurement plane orientation, is smaller than the above, the measurement resolution must be ≤ the corresponding x or y dimension of the test device with at least one measurement point on the test device.	

Step 3: Zoom Scan

Zoom Scan are used to assess the peak spatial SAR value within a cubic average volume containing 1g abd 10g of simulated tissue. The Zoom Scan measures points(refer to table below) within a cube whose base faces are centered on the maxima found in a preceding area scan job within the same procedure. When the measurement is done, the Zoom Scan evaluates the averaged SAR for 1g and 10g and displays these values next to the job's label.

Zoom Scan Parameters extracted from KDB865664 d01 SAR Measurement 100MHz to 6GHz

Maximum zoom scan spatial resolution: Δx_{Zoom} , Δy_{Zoom}		≤ 2 GHz: ≤ 8 mm 2 – 3 GHz: ≤ 5 mm*	3 – 4 GHz: ≤ 5 mm* 4 – 6 GHz: ≤ 4 mm*
Maximum zoom scan spatial resolution, normal to phantom surface	uniform grid: $\Delta z_{Zoom}(n)$	≤ 5 mm	3 – 4 GHz: ≤ 4 mm 4 – 5 GHz: ≤ 3 mm 5 – 6 GHz: ≤ 2 mm
	graded grid	$\Delta z_{Zoom}(1)$: between 1 st two points closest to phantom surface	≤ 4 mm
		$\Delta z_{Zoom}(n>1)$: between subsequent points	$\leq 1.5 \cdot \Delta z_{Zoom}(n-1)$
Minimum zoom scan volume	x, y, z	≥ 30 mm	3 – 4 GHz: ≥ 28 mm 4 – 5 GHz: ≥ 25 mm 5 – 6 GHz: ≥ 22 mm
<p>Note: δ is the penetration depth of a plane-wave at normal incidence to the tissue medium; see draft standard IEEE P1528-2011 for details.</p> <p>* When zoom scan is required and the <i>reported</i> SAR from the <i>area scan based I-g SAR estimation</i> procedures of KDB 447498 is ≤ 1.4 W/kg, ≤ 8 mm, ≤ 7 mm and ≤ 5 mm zoom scan resolution may be applied, respectively, for 2 GHz to 3 GHz, 3 GHz to 4 GHz and 4 GHz to 6 GHz.</p>			

Step 4: Power Drift Measurement

The Power Drift Measurement measures the field at the same location as the most recent power reference measurement within the same procedure, and with the same settings. The Power Drift Measurement gives the field difference in dB from the reading conducted within the same settings. This allows a user to monitor the power drift of the device under test within a batch process. The measurement procedure is the same as Step 1.

4.3. RF Exposure Conditions

Test Configuration and setting:

The EUT is a model of GSM Portable Mobile Station (MS). It supports GSM/GPRS/EGPRS, WCDMA/HSPA, LTE, BT, WIFI, and support hot spot mode.

For WWAN SAR testing, the device was controlled by using a base station emulator. Communication between the device and the emulator were established by air link. The distance between the EUT and the antenna is larger than 50cm, and the output power radiated from the emulator antenna is at least 30db smaller than the output power of EUT.

For WLAN testing, the EUT is configured with the WLAN continuous TX tool through engineering command.

Antenna Location: (the back view)

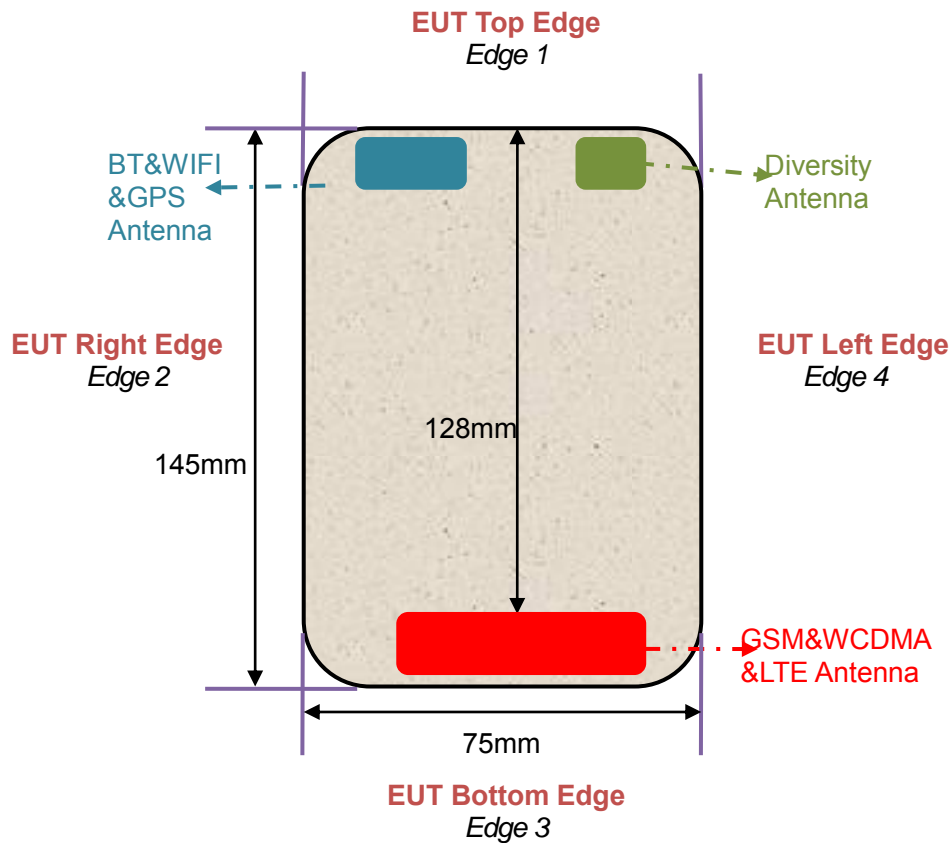

For WWAN mode:

Test Configurations	Antenna to edges/surface	SAR required	Note
Head			
Left Touch		Yes	--
Left Tilt		Yes	--
Right Touch		Yes	--
Right Tilt		Yes	--
Body			
Back	<25mm	Yes	--
Front	<25mm	Yes	--
Hotspot			
Back	<25mm	Yes	--
Front	<25mm	Yes	--
Edge 1 (Top)	128mm	No	SAR is not required for the distance between the antenna and the edge is >25mm as per KDB 941225 D06 Hotspot SAR
Edge 2 (Right)	25mm	No	SAR is not required for the distance between the antenna and the edge is >25mm as per KDB 941225 D06 Hotspot SAR
Edge 3 (Bottom)	2mm	Yes	--
Edge 4 (Left)	8mm	Yes	--

For WLAN mode:

Test Configurations	Antenna to edges/surface	SAR required	Note
Head			
Left Touch		Yes	--
Left Tilt		Yes	--
Right Touch		Yes	--
Right Tilt		Yes	--
Body			
Back	<25mm	Yes	--
Front	<25mm	Yes	--
Hotspot			
Back	<25mm	Yes	--
Front	<25mm	Yes	--
Edge 1 (Top)	5mm	Yes	--
Edge 2 (Right)	15mm	Yes	--
Edge 3 (Bottom)	125mm	No	SAR is not required for the distance between the antenna and the edge is >25mm as per KDB 941225 D06 Hotspot SAR
Edge 4 (Left)	32mm	No	SAR is not required for the distance between the antenna and the edge is >25mm as per KDB 941225 D06 Hotspot SAR

5. TISSUE SIMULATING LIQUID

For SAR measurement of the field distribution inside the phantom, the phantom must be filled with homogeneous tissue simulating liquid to a depth of at least 15cm. For head SAR testing the liquid height from the ear reference point (ERP) of the phantom to the liquid top surface is larger than 15cm For body SAR testing, the liquid height from the center of the flat phantom to the liquid top surface is larger than 15cm. The nominal dielectric values of the tissue simulating liquids in the phantom and the tolerance of 5% are listed in 5.2

5.1. The composition of the tissue simulating liquid

Ingredient (% Weight) Frequency (MHz)	Water	NaCl	Polysorbate 20	DGBE	1,2 Propanediol	Triton X-100
750 Head	35	2	0.0	0.0	63	0.0
750 Body	55	1	0.0	0.0	44	0.0
835 Head	50.36	1.25	48.39	0.0	0.0	0.0
835 Body	54.00	1	0.0	15	0.0	30
1750 Head	52.64	0.36	0.0	47	0.0	0.0
1750 Body	70	1	0.0	9	0.0	20
1900 Head	54.9	0.18	0.0	44.92	0.0	0.0
1900 Body	70	1	0.0	9	0.0	20
2450 Head	71.88	0.16	0.0	7.99	0.0	19.97
2450 Body	70	1	0.0	9	0.0	20
2600 Head	55.242	0.306	0.0	44.452	0.0	0.0
2600 Body	70	1	0.0	9	0.0	20

5.2. Tissue Dielectric Parameters for Head and Body Phantoms

The head tissue dielectric parameters recommended by the IEEE 1528 have been incorporated in the following table. These head parameters are derived from planar layer models simulating the highest expected SAR for the dielectric properties and tissue thickness variations in a human head. Other head and body tissue parameters that have not been specified in IEEE 1528 are derived from the tissue dielectric parameters computed from the 4-Cole-Cole equations described in Reference [12] and extrapolated according to the head parameters specified in IEEE 1528.

Target Frequency (MHz)	head		body	
	ϵ_r	σ (S/m)	ϵ_r	σ (S/m)
300	45.3	0.87	58.2	0.92
450	43.5	0.87	56.7	0.94
750	41.9	0.89	55.5	0.96
835	41.5	0.90	55.2	0.97
900	41.5	0.97	55.0	1.05
915	41.5	1.01	55.0	1.06
1450	40.5	1.20	54.0	1.30
1610	40.3	1.29	53.8	1.40
1750	40.1	1.37	53.4	1.49
1800 – 2000	40.0	1.40	53.3	1.52
2450	39.2	1.80	52.7	1.95
2600	39.00	1.96	52.51	2.16
3000	38.5	2.40	52.0	2.73

(ϵ_r = relative permittivity, ζ = conductivity and $\rho = 1000$ kg/m³)

5.3. Tissue Calibration Result

The dielectric parameters of the liquids were verified prior to the SAR evaluation using SATIMO Dielectric Probe Kit and R&S Network Analyzer ZVL6.

Tissue Stimulant Measurement for 750MHz					
	Fr. (MHz)	Dielectric Parameters ($\pm 5\%$)		Tissue Temp [°C]	Test time
		ϵ_r 41.9 (39.805-43.995)	δ [s/m] 0.89(0.8455-0.9345)		
Head	709	42.75	0.88	21.6	July 04,2017
	710	42.33	0.89		
	711	41.87	0.90		
	750	41.25	0.91		
	Fr. (MHz)	Dielectric Parameters ($\pm 5\%$)		Tissue Temp [°C]	Test time
		ϵ_r 55.5(52.725-58.275)	δ [s/m]0.96(0.912-1.008)		
Body	709	56.42	0.94	21.9	July 04,2017
	710	55.89	0.95		
	711	55.23	0.96		
	750	54.63	0.99		

Tissue Stimulant Measurement for 1750MHz					
	Fr. (MHz)	Dielectric Parameters ($\pm 5\%$)		Tissue Temp [°C]	Test time
		ϵ_r 40.1 (38.095-42.105)	δ [s/m]1.37(1.3015-1.439)		
Head	1712.5	41.89	1.32	21.3	July 02,2017
	1720	41.59	1.33		
	1732.5	41.03	1.35		
	1745	40.67	1.36		
	1750	40.11	1.38		
	1752.5	39.56	1.40		
		Fr. (MHz)	Dielectric Parameters ($\pm 5\%$)		
ϵ_r 53.4(50.73-56.07)			δ [s/m] 1.49(1.4155-1.5645)		
Body	1712.5	55.06	1.43	21.5	July 02,2017
	1720	54.59	1.44		
	1732.5	53.87	1.46		
	1745	53.16	1.47		
	1750	52.66	1.49		
	1752.5	51.09	1.51		

Tissue Stimulant Measurement for 835MHz					
	Fr. (MHz)	Dielectric Parameters ($\pm 5\%$)		Tissue Temp [°C]	Test time
		ϵ_r 41.5 (39.425-43.575)	δ [s/m] 0.90(0.855-0.945)		
Head	824.2	42.86	0.88	21.3	July 02,2017
	826.4	42.31	0.90		
	829	42.01	0.90		
	835	41.79	0.90		
	836.6	41.23	0.91		
	844	40.95	0.92		
	846.6	40.67	0.92		
	848.8	40.11	0.93		
	Fr. (MHz)	Dielectric Parameters ($\pm 5\%$)		Tissue Temp [°C]	Test time
		ϵ_r 55.20(52.44-57.96)	δ [s/m]0.97(0.9215-1.0185)		
Body	824.2	56.55	0.94	21.5	July 02,2017
	826.4	56.03	0.95		
	829	55.74	0.96		
	835	55.67	0.96		
	836.6	55.21	0.97		
	844	54.98	0.97		
	846.6	54.53	0.98		
	848.8	53.89	0.99		

Tissue Stimulant Measurement for 1900MHz					
	Fr. (MHz)	Dielectric Parameters ($\pm 5\%$)		Tissue Temp [°C]	Test time
		ϵ_r 40.00(38.00-42.00)	δ [s/m]1.40(1.33-1.47)		
Head	1850.2	41.10	1.34	21.3	June 28, 2017
	1852.4	40.59	1.36		
	1860	40.22	1.36		
	1880	40.03	1.37		
	1900	39.51	1.38		
	1907.6	39.00	1.40		
	1909.8	38.48	1.42		
		Fr. (MHz)	Dielectric Parameters ($\pm 5\%$)		
ϵ_r 53.30(50.635-55.965)			δ [s/m]1.52(1.444-1.596)		
Body	1850.2	55.15	1.45	21.5	June 28, 2017
	1852.4	54.67	1.47		
	1860	54.26	1.48		
	1880	54.02	1.49		
	1900	53.58	1.51		
	1907.6	52.97	1.52		
	1909.8	52.37	1.54		

Tissue Stimulant Measurement for 2450MHz					
	Fr. (MHz)	Dielectric Parameters ($\pm 5\%$)		Tissue Temp [°C]	Test time
		ϵ_r 39.2(37.24-41.16)	δ [s/m]1.80(1.71-1.89)		
Head	2412	40.29	1.75	21.6	July 12,2017
	2437	39.75	1.80		
	2450	38.59	1.84		
	2462	38.03	1.85		
	Fr. (MHz)	Dielectric Parameters ($\pm 5\%$)		Tissue Temp [°C]	Test time
		ϵ_r 52.7(50.065-55.335)	δ [s/m]1.95(1.8525-2.0475)		
Body	2412	54.63	1.87	21.7	July 12,2017
	2437	53.95	1.90		
	2450	53.12	1.93		
	2462	52.11	1.95		

Tissue Stimulant Measurement for 2600MHz					
	Fr. (MHz)	Dielectric Parameters ($\pm 5\%$)		Tissue Temp [°C]	Test time
		ϵ_r 39.0 (37.05-40.95)	δ [s/m]1.96 (1.86-2.06)		
Head	2510	39.51	1.88	21.1	July 03,2017
	2535	38.95	1.90		
	2560	38.37	1.91		
	2600	37.68	1.92		
	Fr. (MHz)	Dielectric Parameters ($\pm 5\%$)		Tissue Temp [°C]	Test time
		ϵ_r 52.51 (49.88-55.14)	δ [s/m] 2.16 (2.05-2.27)		
Body	2510	54.23	2.10	21.3	July 03,2017
	2535	53.57	2.12		
	2560	52.79	2.14		
	2600	52.00	2.16		

6. SAR SYSTEM CHECK PROCEDURE

6.1. SAR System Check Procedures

SAR system check is required to confirm measurement accuracy, according to the tissue dielectric media, probe calibration points and other system operating parameters required for measuring the SAR of a test device. The system verification must be performed for each frequency band and within the valid range of each probe calibration point required for testing the device. The same SAR probe(s) and tissue-equivalent media combinations used with each specific SAR system for system verification must be used for device testing. When multiple probe calibration points are required to cover substantially large transmission bands, independent system verifications are required for each probe calibration point. A system verification must be performed before each series of SAR measurements using the same probe calibration point and tissue-equivalent medium. Additional system verification should be considered according to the conditions of the tissue-equivalent medium and measured tissue dielectric parameters, typically every three to four days when the liquid parameters are remeasured or sooner when marginal liquid parameters are used at the beginning of a series of measurements.

Each SATIMO system is equipped with one or more system check kits. These units, together with the predefined measurement procedures within the SATIMO software, enable the user to conduct the system check and system validation. System kit includes a dipole, and dipole device holder.

The system check verifies that the system operates within its specifications. It's performed daily or before every SAR measurement. The system check uses normal SAR measurement in the flat section of the phantom with a matched dipole at a specified distance. The system check setup is shown as below.

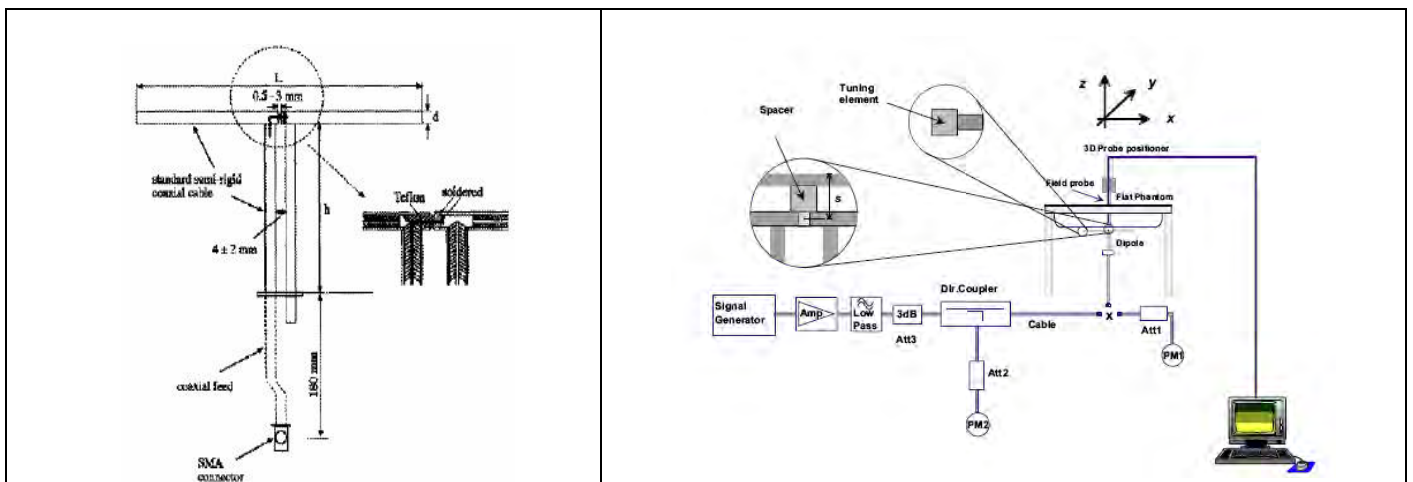

6.2. SAR System Check

6.2.1. Dipoles

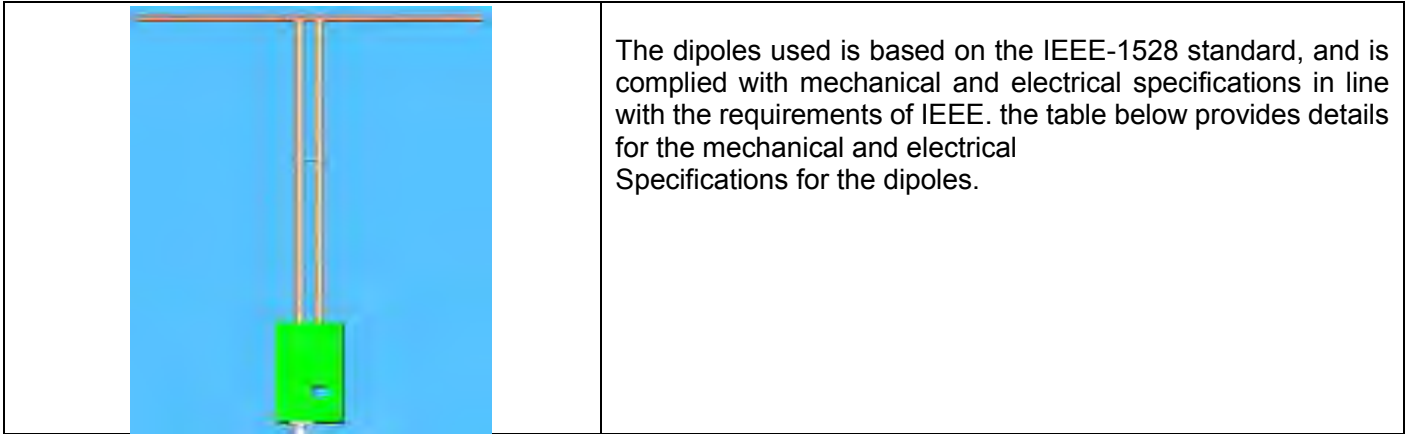

Frequency	L (mm)	h (mm)	d (mm)
750MHz	176	100	6.35
835MHz	161.0	89.8	3.6
1800MHz	71.6	41.7	3.6
1900MHz	68	39.5	3.6
2450MHz	51.5	30.4	3.6
2600MHz	48.5	28.8	3.6

6.2.2. System Check Result

System Performance Check at 750MHz&835MHz &1800MHz &1900MHz &2450MHz & 2600MHz for Head								
Validation Kit: SN47/14 DIP 0G750-340& SN29/15 DIP 0G835-383& SN29/15 DIP 1G800-387&SN 29/15 DIP 1G900-389& SN 29/15DIP 2G450-393 & SN 47/14 DIP 2G600-342								
Frequency [MHz]	Target Value(W/Kg)		Reference Result ($\pm 10\%$)		Tested Value(W/Kg)		Tissue Temp. [°C]	Test time
	1g	10g	1g	10g	1g	10g		
750	8.55	5.62	7.695-9.405	5.058-6.182	9.13	6.05	21.6	July 04,2017
835	10.04	6.43	9.036-11.044	5.787 -7.073	10.12	6.19	21.3	July 02,2017
1800	37.43	19.88	33.687-41.173	17.892-21.868	37.56	20.10	21.3	July 02,2017
1900	41.44	21.33	37.296-45.584	19.197-23.463	40.27	21.16	21.3	June 28, 2017
2450	54.53	24.30	49.077-59.983	21.87-26.730	55.05	24.82	21.6	July 12,2017
2600	55.48	24.49	49.932-61.028	22.041-26.939	55.60	24.98	21.1	July 03,2017
System Performance Check at 750MHz & 835MHz &1800MHz &1900MHz &2450MHz& 2600MHz for Body								
Frequency [MHz]	Target Value(W/Kg)		Reference Result ($\pm 10\%$)		Tested Value(W/Kg)		Tissue Temp. [°C]	Test time
	1g	10g	1g	10g	1g	10g		
750	8.78	5.86	7.902-9.658	5.274-6.446	9.48	5.79	21.9	July 04,2017
835	9.85	6.45	8.865-10.835	5.805-7.095	9.66	5.93	21.5	July 02,2017
1800	36.53	19.80	32.877-40.183	17.82-21.780	35.85	19.18	21.5	July 02,2017
1900	39.38	20.86	35.442-43.318	18.774-22.946	38.30	20.12	21.5	June 28, 2017
2450	49.92	23.16	44.928-54.912	20.844-25.476	51.40	23.14	21.7	July 12,2017
2600	52.19	23.58	46.971-57.409	21.222-25.938	53.72	24.09	21.3	July 03,2017

Note:

(1) We use a CW signal of 18dBm for system check, and then all SAR value are normalized to 1W forward power. The result must be within $\pm 10\%$ of target value.

7. EUT TEST POSITION

This EUT was tested in **Right Cheek, Right Tilted, Left Cheek, Left Tilted, Body back, Body front and 4 edges.**

7.1. Define Two Imaginary Lines on the Handset

- (1) The vertical centerline passes through two points on the front side of the handset: the midpoint of the width w_t of the handset at the level of the acoustic output, and the midpoint of the width w_b of the handset.
- (2) The horizontal line is perpendicular to the vertical centerline and passes through the center of the acoustic output. The horizontal line is also tangential to the face of the handset at point A.
- (3) The two lines intersect at point A. Note that for many handsets, point A coincides with the center of the acoustic output; however, the acoustic output may be located elsewhere on the horizontal line. Also note that the vertical centerline is not necessarily to the front face of the handset, especially for clamshell handsets, handsets with flip covers, and other irregularly shaped handsets.

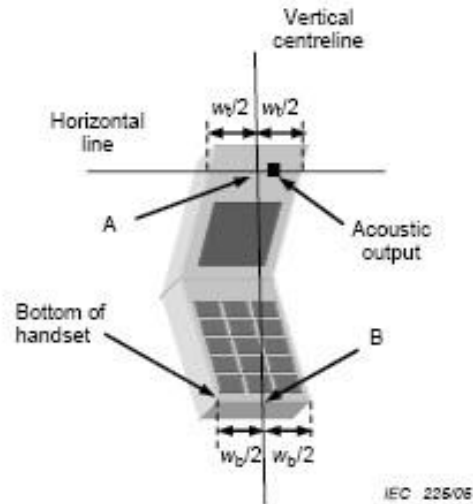
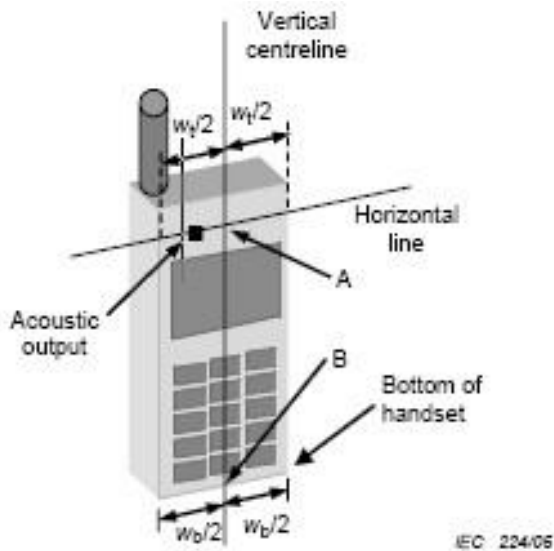

7.2. Cheek Position

- (1) To position the device with the vertical center line of the body of the device and the horizontal line crossing the center piece in a plane parallel to the sagittal plane of the phantom. While maintaining the device in this plane, align the vertical center line with the reference plane containing the ear and mouth reference point (M: Mouth, RE: Right Ear, and LE: Left Ear) and align the center of the ear piece with the line RE-LE.
- (2) To move the device towards the phantom with the ear piece aligned with the the line LE-RE until the phone touched the ear. While maintaining the device in the reference plane and maintaining the phone contact with ear, move the bottom of the phone until any point on the front side is in contact with the cheek of the phantom or until contact with the ear is lost



7.3. Tilt Position

- (1) To position the device in the "cheek" position described above.
- (2) While maintaining the device in the reference plane described above and pivoting against the ear, moves it outward away from the mouth by an angle of 15 degrees or until with the ear is lost.



7.4. Body Worn Position

- (1) To position the EUT parallel to the phantom surface.
- (2) To adjust the EUT parallel to the flat phantom.
- (3) To adjust the distance between the EUT surface and the flat phantom to **5mm**.

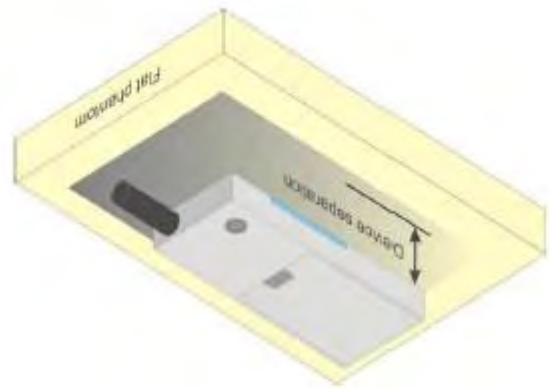
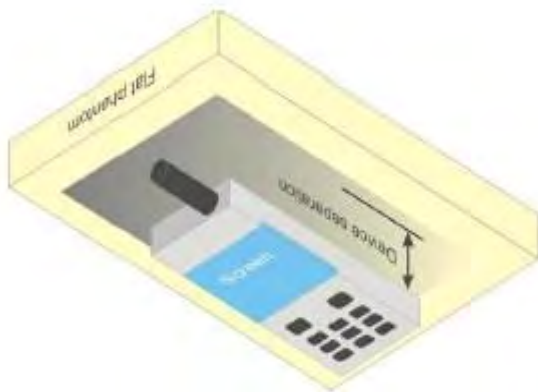

8. SAR EXPOSURE LIMITS

Limits for General Population/Uncontrolled Exposure (W/kg)

Type Exposure	Uncontrolled Environment Limit (W/kg)
Spatial Peak SAR (1g cube tissue for brain or body)	1.60
Spatial Average SAR (Whole body)	0.08
Spatial Peak SAR (Limbs)	4.0

9. TEST EQUIPMENT LIST

Equipment description	Manufacturer/ Model	Identification No.	Current calibration date	Next calibration date
SAR Probe	MVG	SN 14/16 EP308	12/05/2016	12/04/2017
SAR Probe	MVG	SN 14/16 EP307	07/05/2016	07/04/2017
Phantom	SATIMO	SN_4511_SAM90	Validated. No cal required.	Validated. No cal required.
Liquid	SATIMO	-	Validated. No cal required.	Validated. No cal required.
Comm Tester	Agilent-8960	GB46310822	03/02/2017	03/01/2018
Comm Tester	R&S- CMW500	S/N121209	07/18/2016	07/17/2017
Multimeter	Keithley 2000	1188656	03/02/2017	03/01/2018
Dipole	SATIMO SID750	SN47/14 DIP 0G750-340	12/03/2014	12/02/2017
Dipole	SATIMO SID835	SN29/15 DIP 0G835-383	07/05/2016	07/04/2019
Dipole	SATIMO SID1800	SN29/15 DIP 1G800-387	07/05/2016	07/04/2019
Dipole	SATIMO SID1900	SN 29/15 DIP 1G900-389	07/05/2016	07/04/2019
Dipole	SATIMO SID2450	SN29/15 DIP 2G450-393	07/05/2016	07/04/2019
Dipole	SATIMO SID2600	SN47/14 DIP 2G600-342	12/03/2014	12/02/2017
Signal Generator	Agilent-E4438C	US41461365	03/02/2017	03/01/2018
Vector Analyzer	Agilent / E4440A	US41421290	03/02/2017	03/01/2018
Network Analyzer	Rhode & Schwarz ZVL6	SN100132	03/02/2017	03/01/2018
Attenuator	Warison /WATT-6SR1211	N/A	N/A	N/A
Attenuator	Mini-circuits / VAT-10+	N/A	N/A	N/A
Amplifier	EM30180	SN060552	03/02/2017	03/01/2018
Directional Couple	Werlatone/ C5571-10	SN99463	06/20/2017	06/19/2018
Directional Couple	Werlatone/ C6026-10	SN99482	06/20/2017	06/19/2018
Power Sensor	NRP-Z21	1137.6000.02	10/10/2016	10/09/2017
Power Sensor	NRP-Z23	US38261498	03/02/2017	03/01/2018
Power Viewer	R&S	V2.3.1.0	N/A	N/A

Note: Per KDB 865664 Dipole SAR Validation, AGC Lab has adopted 3 years calibration intervals. On annual basis, every measurement dipole has been evaluated and is in compliance with the following criteria:

1. There is no physical damage on the dipole;
2. System validation with specific dipole is within 10% of calibrated value;
3. Return-loss is within 20% of calibrated measurement;
4. Impedance is within 5Ω of calibrated measurement.

10. MEASUREMENT UNCERTAINTY

Per KDB 865664 D01 SAR Measurement 100 MHz to 6 GHz, when the highest measured 1-g SAR within a frequency band is < 1.5 W/Kg, the extensive SAR measurement uncertainty analysis described in IEEE 1528-2013 is not required in SAR reports submitted for equipment approval.

11. CONDUCTED POWER MEASUREMENT GSM BAND

Mode	Frequency(MHz)	Avg. Burst Power(dBm)	Duty cycle Factor(dBm)	Frame Power(dBm)
Maximum Power <1>				
GSM 850	824.2	31.93	-9	22.93
	836.6	31.88	-9	22.88
	848.8	31.69	-9	22.69
GPRS 850 (1 Slot)	824.2	31.56	-9	22.56
	836.6	31.67	-9	22.67
	848.8	31.36	-9	22.36
GPRS 850 (2 Slot)	824.2	28.95	-6	22.95
	836.6	28.69	-6	22.69
	848.8	28.75	-6	22.75
GPRS 850 (3 Slot)	824.2	26.81	-4.26	22.55
	836.6	26.75	-4.26	22.49
	848.8	26.77	-4.26	22.51
GPRS 850 (4 Slot)	824.2	25.58	-3	22.58
	836.6	25.77	-3	22.77
	848.8	25.65	-3	22.65
EGPRS 850 (1 Slot)	824.2	24.78	-9	15.78
	836.6	24.66	-9	15.66
	848.8	24.82	-9	15.82
EGPRS 850 (2 Slot)	824.2	21.70	-6	15.70
	836.6	21.51	-6	15.51
	848.8	21.65	-6	15.65
EGPRS 850 (3 Slot)	824.2	20.46	-4.26	16.20
	836.6	20.41	-4.26	16.15
	848.8	20.36	-4.26	16.10
EGPRS 850 (4 Slot)	824.2	19.09	-3	16.09
	836.6	19.06	-3	16.06
	848.8	19.04	-3	16.04

Mode	Frequency(MHz)	Avg. Burst Power(dBm)	Duty cycle Factor(dBm)	Frame Power(dBm)
Maximum Power <2>				
GSM 850	824.2	31.85	-9	22.85
	836.6	31.33	-9	22.33
	848.8	31.02	-9	22.02
GPRS 850 (1 Slot)	824.2	31.25	-9	22.25
	836.6	31.32	-9	22.32
	848.8	31.21	-9	22.21
GPRS 850 (2 Slot)	824.2	28.12	-6	22.12
	836.6	28.67	-6	22.67
	848.8	28.45	-6	22.45
GPRS 850 (3 Slot)	824.2	26.41	-4.26	22.15
	836.6	26.25	-4.26	21.99
	848.8	26.12	-4.26	21.86
GPRS 850 (4 Slot)	824.2	25.32	-3	22.32
	836.6	25.25	-3	22.25
	848.8	25.12	-3	22.12

GSM BAND CONTINUE

Mode	Frequency(MHz)	Avg. Burst Power(dBm)	Duty cycle Factor(dBm)	Frame Power(dBm)
Maximum Power <1>				
PCS1900	1850.2	27.48	-9	18.48
	1880	27.35	-9	18.35
	1909.8	27.63	-9	18.63
GPRS1900 (1 Slot)	1850.2	27.43	-9	18.43
	1880	27.26	-9	18.26
	1909.8	27.48	-9	18.48
GPRS1900 (2 Slot)	1850.2	24.81	-6	18.81
	1880	24.55	-6	18.55
	1909.8	24.67	-6	18.67
GPRS1900 (3 Slot)	1850.2	22.26	-4.26	18.00
	1880	22.42	-4.26	18.16
	1909.8	22.45	-4.26	18.19
GPRS1900 (4 Slot)	1850.2	21.44	-3	18.44
	1880	21.39	-3	18.39
	1909.8	21.11	-3	18.11
EGPRS1900 (1 Slot)	1850.2	24.52	-9	15.52
	1880	24.84	-9	15.84
	1909.8	25.13	-9	16.13
EGPRS1900 (2 Slot)	1850.2	21.58	-6	15.58
	1880	21.91	-6	15.91
	1909.8	22.01	-6	16.01
EGPRS1900 (3 Slot)	1850.2	21.58	-4.26	17.32
	1880	21.62	-4.26	17.36
	1909.8	21.75	-4.26	17.49
EGPRS1900 (4 Slot)	1850.2	21.09	-3	18.09
	1880	20.93	-3	17.93
	1909.8	21.15	-3	18.15

Mode	Frequency(MHz)	Avg. Burst Power(dBm)	Duty cycle Factor(dBm)	Frame Power(dBm)
Maximum Power <2>				
PCS1900	1850.2	27.02	-9	18.02
	1880	27.11	-9	18.11
	1909.8	27.55	-9	18.55
GPRS1900 (1 Slot)	1850.2	27.25	-9	18.25
	1880	27.05	-9	18.05
	1909.8	27.33	-9	18.33
GPRS1900 (2 Slot)	1850.2	24.80	-6	18.80
	1880	24.51	-6	18.51
	1909.8	24.43	-6	18.43
GPRS1900 (3 Slot)	1850.2	22.12	-4.26	17.86
	1880	22.36	-4.26	18.10
	1909.8	22.31	-4.26	18.05
GPRS1900 (4 Slot)	1850.2	21.25	-3	18.25
	1880	21.29	-3	18.29
	1909.8	21.02	-3	18.02

Note 1:

The Frame Power (Source-based time-averaged Power) is scaled the maximum burst average power based on time slots. The calculated methods are show as following:

Frame Power = Max burst power (1 Up Slot) – 9 dB

Frame Power = Max burst power (2 Up Slot) – 6 dB

Frame Power = Max burst power (3 Up Slot) – 4.26 dB

Frame Power = Max burst power (4 Up Slot) – 3 dB

Note 2:

SAR is not required for GPRS (1 Slot) Mode because its output power is less than of Voice Mode

UMTS BAND

HSDPA Setup Configuration:

- The EUT was connected to Base Station Agilent E5515C referred to the Setup Configuration.
- The RF path losses were compensated into the measurements.
- A call was established between EUT and Based Station with following setting:
 - (1) Set Gain Factors(β_c and β_d) parameters set according to each
 - (2) Set RMC 12.2Kbps+HSDPA mode.
 - (3) Set Cell Power=-86dBm
 - (4) Set HS-DSCH Configuration Type to FRC (H-set 1, QPSK)
 - (5) Select HSDPA Uplink Parameters
 - (6) Set Delta ACK, Delta NACK and Delta CQI=8
 - (7) Set Ack - Nack Repetition Factor to 3
 - (8) Set CQI Feedback Cycle (k) to 4ms
 - (9) Set CQI Repetition Factor to 2
 - (10) Power Ctrl Mode=All Up bits
- The transmitted maximum output power was recorded.

Table C.10.2.4: β values for transmitter characteristics tests with HS-DPCCH

Sub-test	β_c (Note5)	β_d	β_d (SF)	β_c/β_d	β_{HS} (Note1, Note 2)	CM (dB) (Note 3)	MPR (dB) (Note 3)
1	2/15	15/15	64	2/15	4/15	0.0	0.0
2	12/15(Note 4)	15/15(Note 4)	64	12/15(Note 4)	24/15	1.0	0.0
3	15/15	8/15	64	15/8	30/15	1.5	0.5
4	15/15	4/15	64	15/4	30/15	1.5	0.5

Note 1: $\Delta ACK, \Delta NACK$ and $\Delta CQI = 30/15$ with $\beta_{hs} = 30/15 * \beta_c$.

Note 2: For the HS-DPCCH power mask requirement test in clause 5.2C, 5.7A, and the Error Vector Magnitude (EVM) with HS-DPCCH test in clause 5.13.1A, and HSDPA EVM with phase discontinuity in clause 5.13.1AA, ΔACK and $\Delta NACK = 30/15$ with $\beta_{hs} = 30/15 * \beta_c$, and $\Delta CQI = 24/15$ with $\beta_{hs} = 24/15 * \beta_c$.

Note 3: CM = 1 for $\beta_c/\beta_d = 12/15$, $\square_{hs}/\square_c = 24/15$. For all other combinations of DPDCH, DPCCH and HS-DPCCH the MPR is based on the relative CM difference. This is applicable for only UEs that support HSDPA in release 6 and later releases.

Note 4: For subtest 2 the \square_c/\square_d ratio of 12/15 for the TFC during the measurement period (TF1, TF0) is achieved by setting the signalled gain factors for the reference TFC (TF1, TF1) to $\square_c = 11/15$ and $\square_d = 15/15$.

HSUPA Setup Configuration:

- The EUT was connected to Base Station Agilent E5515C referred to the Setup Configuration.
- The RF path losses were compensated into the measurements.
- A call was established between EUT and Base Station with following setting * :
 - (1) Call Configs = 5.2B, 5.9B, 5.10B, and 5.13.2B with QPSK
 - (2) Set the Gain Factors (β_c and β_d) and parameters (AG Index) were set according to each specific sub-test in the following table, C11.1.3, quoted from the TS 34.121
 - (3) Set Cell Power = -86 dBm
 - (4) Set Channel Type = 12.2k + HSPA
 - (5) Set UE Target Power
 - (6) Power Ctrl Mode= Alternating bits
 - (7) Set and observe the E-TFCI
 - (8) Confirm that E-TFCI is equal to the target E-TFCI of 75 for sub-test 1, and other subtest's E-TFCI
- The transmitted maximum output power was recorded.

Table C.11.1.3: β values for transmitter characteristics tests with HS-DPCCH and E-DCH

Sub-test	β_c	β_d	β_d (SF)	β_c/β_d	β_{HS} (Note 1)	β_{ec}	β_{ed} (Note 4) (Note 5)	β_{ed} (SF)	β_{ed} (Code s)	CM (dB) (Note 2)	MPR (dB) (Note 2) (Note 6)	AG Index (Note 5)	E-TF CI
1	11/15 (Note 3)	15/15 (Note 3)	64	11/15 (Note 3)	22/15	209/225	1309/225	4	1	1.0	0.0	20	75
2	6/15	15/15	64	6/15	12/15	12/15	94/75	4	1	3.0	2.0	12	67
3	15/15	9/15	64	15/9	30/15	30/15	β_{ed1} : 47/15 β_{ed2} : 47/15	4 4	2	2.0	1.0	15	92
4	2/15	15/15	64	2/15	4/15	2/15	56/75	4	1	3.0	2.0	17	71
5	15/15	0	-	-	5/15	5/15	47/15	4	1	1.0	0.0	12	67

Note 1: For sub-test 1 to 4, ΔACK , $\Delta NACK$ and $\Delta CQI = 30/15$ with $\beta_{hs} = 30/15 * \beta_c$. For sub-test 5, ΔACK , $\Delta NACK$ and $\Delta CQI = 5/15$ with $\beta_{hs} = 5/15 * \beta_c$.

Note 2: CM = 1 for $\beta_c/\beta_d = 12/15$, $\square_{hs}/\square_c = 24/15$. For all other combinations of DPDCH, DPCCH, HS DPCCH, E-DPDCH and E-DPCCH the MPR is based on the relative CM difference.

Note 3: For subtest 1 the \square_c/\square_d ratio of 11/15 for the TFC during the measurement period (TF1, TF0) is achieved by setting the signalled gain factors for the reference TFC (TF1, TF1) to $\square_c = 10/15$ and $\square_d = 15/15$.

Note 4: In case of testing by UE using E-DPDCH Physical Layer category 1, Sub-test 3 is omitted according to TS25.306 Table 5.1g.

Note 5: β_{ed} cannot be set directly; it is set by Absolute Grant Value.

Note 6: For subtests 2, 3 and 4, UE may perform E-DPDCH power scaling at max power which could results in slightly smaller MPR values.

UMTS BAND II

Mode	Frequency (MHz)	Avg. Burst Power (dBm)
WCDMA 1900 RMC	1852.4	21.82
	1880	21.65
	1907.6	21.53
WCDMA 1900 AMR	1852.4	20.68
	1880	20.51
	1907.6	20.71
HSDPA Subtest 1	1852.4	20.44
	1880	20.80
	1907.6	20.38
HSDPA Subtest 2	1852.4	21.22
	1880	20.87
	1907.6	20.84
HSDPA Subtest 3	1852.4	20.32
	1880	20.47
	1907.6	20.84
HSDPA Subtest 4	1852.4	20.61
	1880	20.27
	1907.6	20.58
HSUPA Subtest 1	1852.4	20.59
	1880	20.20
	1907.6	20.61
HSUPA Subtest 2	1852.4	20.88
	1880	20.41
	1907.6	20.73
HSUPA Subtest 3	1852.4	20.63
	1880	20.29
	1907.6	20.93
HSUPA Subtest 4	1852.4	20.58
	1880	20.47
	1907.6	20.76
HSUPA Subtest 5	1852.4	20.34
	1880	20.61
	1907.6	20.65

UMTS BAND IV

Mode	Frequency (MHz)	Avg. Burst Power (dBm)
WCDMA 1700 RMC	1712.5	20.49
	1732.5	20.62
	1752.5	20.77
WCDMA 1700 AMR	1712.5	20.50
	1732.5	20.35
	1752.5	20.66
HSDPA Subtest 1	1712.5	20.64
	1732.5	20.56
	1752.5	20.55
HSDPA Subtest 2	1712.5	20.26
	1732.5	20.61
	1752.5	20.57
HSDPA Subtest 3	1712.5	20.33
	1732.5	20.42
	1752.5	20.41
HSDPA Subtest 4	1712.5	20.41
	1732.5	20.37
	1752.5	20.27
HSUPA Subtest 1	1712.5	20.61
	1732.5	20.57
	1752.5	20.49
HSUPA Subtest 2	1712.5	20.59
	1732.5	20.63
	1752.5	20.22
HSUPA Subtest 3	1712.5	20.45
	1732.5	20.30
	1752.5	20.58
HSUPA Subtest 4	1712.5	20.55
	1732.5	20.31
	1752.5	20.32
HSUPA Subtest 5	1712.5	20.69
	1732.5	20.36
	1752.5	20.46

UMTS BAND V

Mode	Frequency (MHz)	Avg. Burst Power (dBm)
WCDMA 850 RMC	826.4	20.65
	836.6	20.39
	846.6	20.74
WCDMA 850 AMR	826.4	20.70
	836.6	20.52
	846.6	20.67
HSDPA Subtest 1	826.4	20.25
	836.6	20.33
	846.6	20.40
HSDPA Subtest 2	826.4	20.35
	836.6	20.34
	846.6	20.58
HSDPA Subtest 3	826.4	20.20
	836.6	20.11
	846.6	20.40
HSDPA Subtest 4	826.4	20.08
	836.6	20.02
	846.6	20.16
HSUPA Subtest 1	826.4	20.50
	836.6	20.43
	846.6	20.40
HSUPA Subtest 2	826.4	20.48
	836.6	20.26
	846.6	20.47
HSUPA Subtest 3	826.4	20.43
	836.6	20.36
	846.6	20.33
HSUPA Subtest 4	826.4	20.42
	836.6	20.30
	846.6	20.36
HSUPA Subtest 5	826.4	20.09
	836.6	20.44
	846.6	20.21

According to 3GPP 25.101 sub-clause 6.2.2 , the maximum output power is allowed to be reduced by following the table.

Table 6.1aA: UE maximum output power with HS-DPCCH and E-DCH

UE Transmit Channel Configuration	CM(db)	MPR(db)
For all combinations of ,DPDCH,DPCCH HS-DPDCH,E-DPDCH and E-DPCCH	$0 \leq CM \leq 3.5$	$MAX(CM-1,0)$
Note: CM=1 for $\beta_c/\beta_d=12/15$, $\beta_{hs}/\beta_c=24/15$.For all other combinations of DPDCH, DPCCH, HS-DPCCH, E-DPDCH and E-DPCCH the MPR is based on the relative CM difference.		

The device supports MPR to solve linearity issues (ACLR or SEM) due to the higher peak-to average ratios (PAR) of the HSUPA signal. This prevents saturating the full range of the TX DAC inside of device and provides a reduced power output to the RF transceiver chip according to the Cubic Metric (a function of the combinations of DPDCH, DPCCH, HS-DPCCH, E-DPDCH and E-DPCCH).

When E-DPDCH channels are present the beta gains on those channels are reduced firsts to try to get the power under the allowed limit. If the beta gains are lowered as far as possible, then a hard limiting is applied at the maximum allowed level.

The SW currently recalculates the cubic metric every time the beta gains on the E-DPDCH are reduced. The cubic metric will likely get lower each time this is done .However, there is no reported reduction of maximum output power in the HSUPA mode since the device also provides a compensation for the power back-off by increasing the gain of TX_AGC in the transceiver (PA) device.

The end effect is that the DUT output power is identical to the case where there is no MPR in the device.

LTE Band

Conducted Power of LTE Band II(dBm)							
Bandwidth	Modulation	RB size	RB offset	Target MPR	Channel	Channel	Channel
					18607	18900	19193
1.4MHz	QPSK	1	0	0	21.95	21.56	21.60
			3	0	22.00	20.94	21.59
			5	0	21.88	21.99	21.30
		3	0	0	21.63	22.08	22.40
			2	0	21.26	22.67	21.12
			3	0	21.19	22.22	21.41
	6	0	1	21.64	21.62	20.81	
	16QAM	1	0	1	21.48	22.07	21.58
			3	1	21.96	21.44	21.53
			5	1	22.29	21.35	21.00
		3	0	1	21.89	22.57	21.37
			2	1	21.65	21.21	21.92
			3	1	22.46	21.21	21.68
	6	0	2	22.18	22.10	21.74	
Bandwidth	Modulation	RB size	RB offset	Target MPR	Channel	Channel	Channel
					18615	18900	19185
3MHz	QPSK	1	0	0	21.96	22.68	22.48
			7	0	21.63	22.26	22.79
			14	0	21.98	21.22	21.06
		8	0	1	21.58	21.44	21.26
			4	1	21.28	21.91	21.73
			7	1	20.71	21.47	21.26
	15	0	1	21.87	21.27	21.62	
	16QAM	1	0	1	21.93	21.37	22.50
			7	1	22.40	21.95	22.18
			14	1	22.07	21.67	22.17
		8	0	2	21.34	21.46	20.95
			4	2	22.42	22.08	21.04
			7	2	22.32	21.65	21.80
	15	0	2	22.19	21.74	21.49	

Conducted Power of LTE Band II(dBm)									
Bandwidth	Modulation	RB size	RB offset	Target MPR	Channel	Channel	Channel		
					18625	18900	19175		
5MHz	QPSK	1	0	0	21.44	21.38	21.16		
			13	0	21.88	20.91	22.04		
			24	0	20.94	21.66	21.90		
		12	0	1	20.90	21.96	21.34		
			6	1	21.36	21.64	21.97		
			13	1	21.30	21.42	22.97		
		25	0	1	20.98	22.03	22.43		
		16QAM	1	0	1	21.03	21.57	22.01	
				13	1	21.18	21.30	22.00	
	24			1	22.19	21.05	21.91		
	12		0	2	21.61	22.19	22.15		
			6	2	21.67	20.47	22.71		
			13	2	22.57	21.20	22.05		
	25		0	2	21.46	22.53	21.74		
	Bandwidth		Modulation	RB size	RB offset	Target MPR	Channel	Channel	Channel
							18650	18900	19150
	10MHz	QPSK	1	0	0	22.51	22.33	22.32	
				25	0	20.75	20.96	21.15	
49				0	21.58	22.70	22.15		
25			0	1	20.97	21.76	21.40		
			13	1	21.92	22.42	21.05		
			25	1	22.11	20.95	22.92		
50			0	1	21.08	22.03	22.35		
16QAM			1	0	1	21.09	22.50	21.39	
				25	1	22.00	21.51	21.65	
		49		1	21.01	22.02	22.20		
		25	0	2	21.49	21.47	22.36		
			13	2	22.37	21.82	22.10		
			25	2	21.25	21.12	21.23		
		50	0	2	20.67	21.10	21.11		

Conducted Power of LTE Band II(dBm)								
Bandwidth	Modulation	RB size	RB offset	Target MPR	Channel	Channel	Channel	
					18675	18900	19125	
15MHz	QPSK	1	0	0	21.48	21.43	21.38	
			38	0	21.34	21.29	20.95	
			74	0	21.98	22.10	20.98	
		36	0	1	20.94	22.57	21.49	
			18	1	22.47	21.53	21.15	
			39	1	22.08	22.01	21.24	
	75	0	1	20.99	21.72	21.32		
	16QAM	1	0	1	20.72	20.84	21.43	
			38	1	21.55	22.21	22.51	
			74	1	22.12	21.77	21.62	
		36	0	2	21.05	21.41	22.33	
			18	2	22.09	22.18	21.76	
			39	2	21.01	20.99	22.16	
		75	0	2	22.89	21.42	21.23	
		Bandwidth	Modulation	RB size	RB offset	Target MPR	Channel	Channel
						18700	18900	19100
20MHz	QPSK	1	0	0	22.31	21.19	22.50	
			50	0	22.39	22.10	22.75	
			99	0	21.05	20.99	21.65	
		50	0	1	22.20	21.12	21.58	
			25	1	21.69	21.89	21.57	
			50	1	21.70	22.42	22.05	
	100	0	1	21.88	21.91	22.21		
	16QAM	1	0	1	20.96	21.39	22.07	
			50	1	22.69	22.90	21.37	
			99	1	21.28	21.90	21.60	
		50	0	2	20.88	21.00	22.15	
			25	2	21.66	21.69	22.47	
			50	2	21.06	22.35	22.14	
		100	0	2	21.41	22.28	22.70	

Conducted Power of LTE Band IV(dBm)								
Bandwidth	Modulation	RB size	RB offset	Target MPR	Channel	Channel	Channel	
					19957	20175	20393	
1.4MHz	QPSK	1	0	0	21.51	21.26	20.65	
			3	0	21.30	22.20	22.01	
			5	0	22.64	21.08	21.39	
		3	0	0	21.44	21.96	21.72	
			2	0	21.76	22.54	21.28	
			3	0	22.01	21.85	20.45	
		6	0	1	22.20	21.35	21.79	
		16QAM	1	0	1	22.27	22.04	21.60
				3	1	21.36	21.67	21.94
	5			1	21.72	21.86	22.00	
	3		0	1	21.62	22.06	22.48	
			2	1	21.14	21.22	22.23	
			3	1	21.00	21.44	20.79	
	6	0	2	21.67	21.47	20.75		
	Bandwidth	Modulation	RB size	RB offset	Target MPR	Channel	Channel	Channel
					19965	20175	20385	
3MHz	QPSK	1	0	0	21.98	22.34	21.52	
			7	0	22.22	21.25	21.41	
			14	0	22.23	22.14	21.76	
		8	0	1	20.87	21.02	20.74	
			4	1	22.22	22.57	22.55	
			7	1	21.26	22.53	21.28	
		15	0	1	20.88	21.78	20.81	
		16QAM	1	0	1	22.50	22.08	21.51
				7	1	22.03	21.30	21.24
	14			1	22.04	21.22	22.01	
	8		0	2	21.01	21.59	21.87	
			4	2	21.77	21.48	21.69	
			7	2	21.31	22.13	21.63	
	15	0	2	21.20	21.19	22.15		

Conducted Power of LTE Band IV(dBm)								
Bandwidth	Modulation	RB size	RB offset	Target MPR	Channel	Channel	Channel	
					19975	20175	20375	
5MHz	QPSK	1	0	0	21.47	22.50	22.16	
			13	0	21.19	22.08	21.18	
			24	0	22.74	21.64	20.90	
		12	0	1	21.13	21.57	22.03	
			6	1	21.67	21.41	21.19	
			13	1	21.66	21.56	21.53	
		25	0	1	20.86	21.02	21.83	
		16QAM	1	0	1	21.00	21.40	21.45
				13	1	21.29	21.52	20.92
	24			1	21.64	21.88	21.04	
	12		0	2	22.68	21.46	21.77	
			6	2	21.78	22.13	21.50	
			13	2	21.83	21.49	22.18	
	25	0	2	21.35	21.47	21.85		
	Bandwidth	Modulation	RB size	RB offset	Target MPR	Channel	Channel	Channel
					20000	20175	20350	
10MHz	QPSK	1	0	0	21.22	22.53	22.11	
			25	0	21.95	22.72	21.38	
			49	0	22.47	22.14	22.00	
		25	0	1	22.28	21.05	21.58	
			13	1	21.84	21.12	21.55	
			25	1	22.27	22.18	21.49	
		50	0	1	21.82	21.23	21.10	
		16QAM	1	0	1	21.53	21.03	21.22
				25	1	20.76	21.51	21.67
	49			1	21.86	22.42	21.47	
	25		0	2	21.15	22.23	21.70	
			13	2	21.57	21.17	22.23	
			25	2	21.71	21.89	22.38	
	50	0	2	21.65	22.25	21.84		

Conducted Power of LTE Band IV(dBm)							
Bandwidth	Modulation	RB size	RB offset	Target MPR	Channel	Channel	Channel
					20025	20175	20325
15MHz	QPSK	1	0	0	21.81	22.78	22.11
			38	0	21.10	22.77	20.77
			74	0	21.45	21.13	21.65
		36	0	1	21.59	22.48	22.14
			18	1	21.85	22.28	21.14
			39	1	21.17	21.96	21.31
	75	0	1	21.92	21.51	21.52	
	16QAM	1	0	1	22.04	21.80	21.34
			38	1	21.52	21.95	21.49
			74	1	22.62	22.27	21.46
		36	0	2	20.98	22.32	22.93
			18	2	21.15	21.29	21.65
			39	2	21.92	22.24	21.88
	75	0	2	21.66	21.87	21.35	
Bandwidth	Modulation	RB size	RB offset	Target MPR	Channel	Channel	Channel
					20050	20175	20300
20MHz	QPSK	1	0	0	20.77	22.73	21.45
			50	0	20.98	20.98	21.18
			99	0	21.62	21.84	21.42
		50	0	1	21.33	22.11	21.22
			25	1	22.01	21.75	21.07
			50	1	21.89	22.89	21.58
	100	0	1	22.07	21.11	21.91	
	16QAM	1	0	1	21.10	21.33	21.00
			50	1	22.40	21.78	21.76
			99	1	21.90	22.13	22.30
		50	0	2	21.22	21.46	22.46
			25	2	22.08	21.92	21.29
			50	2	22.28	21.54	22.20
	100	0	2	22.05	21.82	21.34	

Conducted Power of LTE Band V(dBm)							
Bandwidth	Modulation	RB size	RB offset	Target MPR	Channel	Channel	Channel
					20407	20525	20643
1.4MHz	QPSK	1	0	0	21.45	21.37	22.33
			3	0	21.48	21.86	21.44
			5	0	21.40	21.37	22.44
		3	0	0	21.26	21.46	22.17
			2	0	22.35	22.16	21.37
			3	0	21.66	21.03	20.85
	6	0	1	22.02	21.91	21.81	
	16QAM	1	0	1	21.62	22.34	21.07
			3	1	22.04	21.34	21.60
			5	1	22.72	22.46	20.85
		3	0	1	22.75	21.53	21.85
			2	1	21.13	21.46	21.58
			3	1	21.94	22.08	21.28
	6	0	2	21.83	22.20	20.84	
	Bandwidth	Modulation	RB size	RB offset	Target MPR	Channel	Channel
20415						20525	20635
3MHz	QPSK	1	0	0	22.68	20.86	21.64
			7	0	21.30	21.32	21.77
			14	0	21.38	21.80	21.51
		8	0	1	21.27	22.15	22.71
			4	1	21.97	21.33	21.67
			7	1	21.38	22.22	20.93
	15	0	1	20.81	21.29	21.12	
	16QAM	1	0	1	21.85	21.25	21.30
			7	1	21.17	21.65	21.99
			14	1	21.67	21.57	21.16
		8	0	2	21.47	21.42	22.77
			4	2	21.96	22.35	22.00
			7	2	21.67	20.81	22.68
	15	0	2	22.10	21.37	22.72	

Conducted Power of LTE Band V(dBm)							
Bandwidth	Modulation	RB size	RB offset	Target MPR	Channel	Channel	Channel
					20425	20525	20625
5MHz	QPSK	1	0	0	21.47	21.62	21.69
			13	0	22.21	21.76	21.44
			24	0	21.74	21.56	21.45
		12	0	1	22.33	22.20	21.67
			6	1	21.01	22.06	22.26
			13	1	22.43	21.31	21.25
	25	0	1	22.28	21.30	22.40	
	16QAM	1	0	1	22.49	22.15	20.94
			13	1	21.50	21.53	21.59
			24	1	21.77	21.67	21.49
		12	0	2	22.14	22.19	21.66
			6	2	22.21	21.56	21.72
			13	2	20.96	22.29	20.93
		25	0	2	20.95	21.20	21.51
Bandwidth		Modulation	RB size	RB offset	Target MPR	Channel	Channel
					20450	20525	20600
10MHz	QPSK	1	0	0	21.05	22.07	22.21
			25	0	20.92	20.95	20.93
			49	0	21.84	21.52	22.06
		25	0	1	21.93	22.23	21.15
			13	1	22.11	21.17	22.35
			25	1	22.49	21.97	21.62
	50	0	1	21.58	21.39	21.66	
	16QAM	1	0	1	20.96	22.10	21.01
			25	1	20.96	21.68	21.42
			49	1	20.89	21.88	21.82
		25	0	2	21.38	21.65	22.79
			13	2	22.32	22.92	21.65
			25	2	21.10	21.11	22.76
		50	0	2	21.75	21.55	21.72

Conducted Power of LTE Band VII (dBm)							
Bandwidth	Modulation	RB size	RB offset	Target MPR	Channel	Channel	Channel
					20775	21100	21425
5MHz	QPSK	1	0	0	21.31	22.28	21.66
			12	0	21.79	22.02	21.92
			24	0	22.34	21.48	22.04
		12	0	1	22.29	21.75	22.44
			6	1	21.38	22.35	22.32
			13	1	20.95	22.28	21.31
	25	1	22.53	22.28	21.79		
	16QAM	1	0	1	22.16	21.48	22.34
			12	1	21.62	22.94	22.29
			24	1	22.07	21.63	21.38
		12	0	2	21.97	21.82	20.95
			6	2	21.66	21.17	22.53
			13	2	21.99	21.64	22.16
		25	2	21.75	21.80	21.62	
Bandwidth		Modulation	RB size	RB offset	Target MPR	Channel	Channel
	20800					21100	21400
10MHz	QPSK	1	0	0	21.92	22.66	21.65
			24	0	21.74	21.75	21.28
			49	0	22.52	22.00	21.62
		25	0	1	22.30	22.43	22.23
			12	1	22.52	21.79	21.86
			25	1	21.33	22.32	21.92
	50	1	22.48	21.91	21.74		
	16QAM	1	0	1	22.40	21.70	22.52
			24	1	21.38	21.93	22.30
			49	1	21.29	21.56	22.52
		25	0	2	22.83	21.72	21.33
			12	2	22.02	21.82	22.48
			25	2	22.07	22.13	22.40
		50	2	21.23	22.23	21.38	

Conducted Power of LTE Band VII (dBm)							
Bandwidth	Modulation	RB size	RB offset	Target MPR	Channel	Channel	Channel
					20825	21100	21375
15MHz	QPSK	1	0	0	21.43	22.54	21.51
			37	0	22.34	21.32	22.35
			74	0	21.61	22.61	21.85
		37	0	1	22.48	22.01	21.69
			19	1	22.12	21.96	22.34
			38	1	22.01	22.15	21.43
	75	0	1	22.54	22.00	22.34	
	16QAM	1	0	1	22.49	21.75	21.61
			37	1	21.67	21.64	22.48
			74	1	21.11	21.86	22.12
		37	0	2	21.80	21.88	22.01
			19	2	22.41	22.25	22.54
			38	2	21.80	22.60	22.49
	75	0	2	21.99	21.76	21.67	
Bandwidth	Modulation	RB size	RB offset	Target MPR	Channel	Channel	Channel
					20850	21100	21350
20MHz	QPSK	1	0	0	21.30	22.34	21.86
			49	0	21.41	21.96	22.41
			99	0	22.27	22.29	21.94
		50	0	1	22.19	21.89	22.55
			25	1	21.70	22.65	21.90
			50	1	22.19	22.24	21.30
	100	0	1	22.28	20.94	21.41	
	16QAM	1	0	1	22.57	22.00	22.27
			49	1	21.75	22.03	22.19
			99	1	21.56	21.78	21.70
		50	0	2	22.32	21.65	22.19
			25	2	21.85	22.06	22.28
			50	2	22.48	21.76	22.57
	100	0	2	20.94	22.01	21.75	

Conducted Power of LTE Band XVII(dBm)							
Bandwidth	Modulation	RB size	RB offset	Target MPR	Channel	Channel	Channel
					23755	23790	23825
5MHz	QPSK	1	0	0	21.37	20.95	22.31
			13	0	21.30	21.01	22.14
			24	0	21.01	22.84	22.13
		12	0	1	22.62	22.49	20.72
			6	1	20.91	22.27	21.68
			13	1	22.45	21.72	22.17
	25	0	1	22.16	21.30	21.70	
	16QAM	1	0	1	22.07	22.14	21.96
			13	1	22.24	21.95	21.68
			24	1	21.60	22.23	22.60
		12	0	2	21.55	21.70	22.27
			6	2	21.40	21.18	22.36
			13	2	21.41	22.21	21.30
		25	0	2	21.65	21.75	21.02
Bandwidth		Modulation	RB size	RB offset	Target MPR	Channel	Channel
					23780	23790	23800
10MHz	QPSK	1	0	0	21.74	22.55	22.32
			25	0	21.39	21.92	20.98
			49	0	21.54	22.19	21.76
		25	0	1	21.94	21.21	20.85
			13	1	22.19	22.94	20.79
			25	1	22.03	22.51	21.35
	50	0	1	22.66	21.73	22.44	
	16QAM	1	0	1	21.38	21.65	22.41
			25	1	22.31	21.55	22.17
			49	1	21.12	21.70	22.18
		25	0	2	21.71	21.90	21.69
			13	2	20.70	22.41	22.32
			25	2	22.01	21.57	21.22
		50	0	2	22.44	21.93	21.91

The following tests were conducted according to the test requirements outlined in section 6.2 of the 3GPP TS36.101 specification.

UE Power Class: 3 (23 +/- 2dBm). The allowed Maximum Power Reduction (MPR) for the maximum output power due to higher order modulation and transmit bandwidth configuration (resource blocks) is specified in Table 6.2.3.3-1 of the 3GPP TS36.101.

Table 6.2.3.3-1 Maximum Power Reduction (MPR) for Power class3

Modulation	Maximum Power Reduction (MPR) for Power[RB]						MPR(dB)
	1.4MHz	3MHz	5MHz	10MHz	15MHz	20MHz	
QPSK	>5	>4	>8	>12	>16	>18	≤1
16QAM	≤5	≤4	≤8	≤12	≤16	≤18	≤1
16QAM	>5	>4	>8	>12	>16	>18	≤2

The allowed A-MPR values specified below in Table 6.2.4.3-1 of 3GPP TS36.101 are in addition to the allowed MPR requirements. All the measurements below were performed with A-MPR disabled, by using Network Signaling Value of "NS_01".3

Table 6.2.4.3-1: Additional Maximum Power Reduction (A-MPR) / Spectrum Emission requirements

Network Signaling value	Requirements (sub-clause)	E-UTRA Band	Channel bandwidth (MHz)	Resources Blocks (N_{RB})	A-MPR (dB)
NS_01	6.6.2.1.1	Table 5.2-1	1.4,3,5,10,15,20	Table 5.4.2-1	N/A
NS_03	6.6.2.2.3.1	2,4,10, 23, 25,35,36	3	>5	≤ 1
			5	>6	≤ 1
			10	>6	≤ 1
			15	>8	≤ 1
			20	>10	≤ 1
NS_04	6.6.2.2.3.2	41	5	>6	≤ 1
			10, 15, 20	Table 6.2.4.3-4	
NS_05	6.6.3.3.3.1	1	10,15,20	≥ 50	≤ 1
NS_06	6.6.2.2.3.3	12, 13, 14, 17	1.4, 3, 5, 10	Table 5.4.2-1	N/A
NS_07	6.6.2.2.3.3 6.6.3.3.3.2	13	10	Table 6.2.4.3-2	Table 6.2.4.3-2
NS_08	6.6.3.3.3.3	19	10, 15	> 44	≤ 3
NS_09	6.6.3.3.3.4	21	10, 15	> 40	≤ 1
				> 55	≤ 2
				Table 6.2.4.3-3	
NS_10		20	15, 20	Table 6.2.4.3-3	Table 6.2.4.3-3
NS_11	6.6.2.2.1 6.6.3.3.13	231	1.4, 3, 5, 10,15,20	Table 6.2.4.3-5	Table 6.2.4.3-5
NS_12	6.6.3.3.5	26	1.4, 3, 5	Table 6.2.4.3-6	Table 6.2.4.3-6
NS_13	6.6.3.3.6	26	5	Table 6.2.4.3-7	Table 6.2.4.3-7
NS_14	6.6.3.3.7	26	10, 15	Table 6.2.4.3-8	Table 6.2.4.3-8
NS_15	6.6.3.3.8	26	1.4, 3, 5, 10, 15	Table 6.2.4.3-9 Table 6.2.4.3-10	Table 6.2.4.3-9, Table 6.2.4.3-10
NS_16	6.6.3.3.9	27	3, 5, 10	Table 6.2.4.3-11, Table 6.2.4.3-12, Table 6.2.4.3-13	
NS_17	6.6.3.3.10 6.6.3.3.11	28 28	5, 10	Table 5.4.2-1	N/A
			5	≥ 2	≤ 1
NS_18			10, 15, 20	≥ 1	≤ 4
NS_19			10, 15, 20	Table 6.2.4.3-15	Table 6.2.4.3-15
NS_20			5, 10, 15, 20	Table 6.2.4.3-14	Table 6.2.4.3-14
...					
NS_20	-	-	-	-	-

WIFI

Mode	Data Rate (Mbps)	Channel	Frequency(MHz)	Avg. Burst Power(dBm)
802.11b	1	01	2412	10.11
		06	2437	12.59
		11	2462	11.67
802.11g	6	01	2412	6.82
		06	2437	10.62
		11	2462	9.76
802.11n(20)	6.5	01	2412	6.85
		06	2437	10.55
		11	2462	9.80
802.11n(40)	13.5	03	2422	10.30
		06	2437	10.32
		09	2452	8.85

Bluetooth_V3.0

Modulation	Channel	Frequency(MHz)	Peak Power (dBm)
GFSK	0	2402	-1.344
	39	2441	0.119
	78	2480	1.133
$\pi/4$ -DQPSK	0	2402	-2.536
	39	2441	-0.838
	78	2480	0.230
8-DPSK	0	2402	-2.617
	39	2441	-1.045
	78	2480	-0.117

Bluetooth_V4.0

Modulation	Channel	Frequency(MHz)	Peak Power (dBm)
GFSK	0	2402	-1.250
	19	2440	1.153
	39	2480	1.483

12. TEST RESULTS

12.1. SAR Test Results Summary

12.1.1. Test position and configuration

Head SAR was performed with the device configured in the positions according to IEEE 1528-2013, Body-worn SAR was performed with the device 5mm from the phantom, and 4 Edges SAR was performed with the device 10mm from the phantom.

12.1.2. Operation Mode

1. Per KDB 447498 D01 v06 ,for each exposure position, if the highest 1-g SAR is ≤ 0.8 W/kg, testing for low and high channel is optional.
2. Per KDB 865664 D01 v01r04,for each frequency band, if the measured SAR is ≥ 0.8 W/Kg, testing for repeated SAR measurement is required , that the highest measured SAR is only to be tested. When the SAR results are near the limit, the following procedures are required for each device to verify these types of SAR measurement related variation concerns by repeating the highest measured SAR configuration in each frequency band.
 - (1) When the original highest measured SAR is ≥ 0.8 W/Kg, repeat that measurement once.
 - (2) Perform a second repeated measurement only if the ratio of largest to smallest SAR for the original and first repeated measurements is >1.20 or when the original or repeated measurement is ≥ 1.45 W/Kg.
 - (3) Perform a third repeated measurement only if the original, first and second repeated measurement is ≥ 1.5 W/Kg and ratio of largest to smallest SAR for the original, first and second measurement is ≥ 1.20 .
3. Body-worn exposure conditions are intended to voice call operations, therefore GSM voice call mode is selected to be test.
4. Per KDB 648474 D04 v01r03,when the reported SAR for a body-worn accessory measured without a headset connected to the handset is ≤ 1.2 W/Kg, SAR testing with a headset connected is not required.
5. Per KDB 248227 D01v02r02,for 2.4GHz 802.11g/n SAR testing is not required when the highest reported SAR for DSSS is adjusted by the ratio of OFDM to DSSS specified maximum output power and the adjusted SAR is ≤ 1.2 W/kg.
6. Per KDB 941225 D06 V02r01, When the same wireless mode transmission configurations for voice and data are required for SAR measurements, the more conservative configuration with a smaller separation distance should be tested for the overlapping SAR configurations.
7. Maximum Scaling SAR in order to calculate the Maximum SAR values to test under the standard Peak Power, Calculation method is as follows:
Maximum Scaling SAR =tested SAR (Max.) \times [maximum turn-up power (mw)/ maximum measurement output power(mw)]
8. Proximity sensor, just for avoiding the wrong operation in the phone screen when call, and has no influence on output power or SAR result
8. Per KDB 941225 D05v02r03, start with the largest channel bandwidth and measure SAR for QPSK with 1RB allocation using the RB offset and required test channel combination with highest maximum output power for RB offsets at the upper edge, middle and lower edge of each required test channel.
9. Per KDB 941125 D05v02r03, 50% RB allocation for QPSK SAR testing follows 1RB QPSK allocation procedure.
10. Per KDB 941125 D05v02r03. For QPSK with 100% RB allocation. SAR is not required when the highest maximum output power for 100% RB allocation is less than the highest maximum output power in 50% and

1RB allocation and the highest reported SAR is >1.45 W/Kg, the remaining required test channels must also be tested.

11. Per KDB 941125 D05v02r03. 16QAM output power for each RB allocation configuration is not 1/2 dB higher than the same configuration in QPSK and the reported SAR for the QPSK configuration is ≤ 1.45 W/Kg, Per KDB 941225 D05v02r02, 16QAM SAR testing is not required.
12. Per KDB 941125 D05v02r03. Smaller bandwidth output power for each RB allocation configuration is $>$ not 1/2 dB higher than the same configuration in the largest supported bandwidth, and the reported SAR for the largest supported bandwidth is ≤ 1.45 W/Kg. Per KDB 941125 D05v02r03, smaller bandwidth SAR testing is not required.

12.1.3. Test Result

SAR MEASUREMENT									
Depth of Liquid (cm):>15					Relative Humidity (%): 50.8				
Product: Rugged Mobile Phone									
Test Mode: GSM850 with GMSK modulation									
Position	Mode	Ch.	Fr. (MHz)	Power Drift (<±5%)	SAR (1g) (W/kg)	Max. Tune-up Power (dBm)	Meas. output Power (dBm)	Scaled SAR (W/Kg)	Limit (W/kg)
SIM 1 Card									
Left Cheek	voice	190	836.6	-0.23	0.245	32.00	31.88	0.252	1.6
Left Tilt	voice	190	836.6	1.33	0.154	32.00	31.88	0.158	1.6
Right Cheek	voice	190	836.6	0.02	0.277	32.00	31.88	0.285	1.6
Right Tilt	voice	190	836.6	-0.23	0.177	32.00	31.88	0.182	1.6
Body back	voice	190	836.6	1.33	0.459	32.00	31.88	0.472	1.6
Body front	voice	190	836.6	0.02	0.364	32.00	31.88	0.374	1.6
SIM 2Card									
Left Cheek	GPRS-2 slot	190	836.6	-0.23	0.374	28.95	28.69	0.397	1.6
Left Tilt	GPRS-2 slot	190	836.6	0.02	0.265	28.95	28.69	0.281	1.6
Right Cheek	GPRS-2 slot	190	836.6	1.33	0.449	28.95	28.69	0.477	1.6
Right Tilt	GPRS-2 slot	190	836.6	-0.02	0.272	28.95	28.69	0.289	1.6
Body back	GPRS-2 slot	190	836.6	-0.23	0.729	28.95	28.69	0.774	1.6
Body front	GPRS-2 slot	190	836.6	-1.33	0.578	28.95	28.69	0.614	1.6
Edge 1 (Top)	GPRS-2 slot	190	836.6	0.02	0.028	28.95	28.69	0.030	1.6
Edge 2(Right)	GPRS-2 slot	190	836.6	0.23	0.319	28.95	28.69	0.339	1.6
Edge 3(Bottom)	GPRS-2 slot	190	836.6	-1.33	0.160	28.95	28.69	0.170	1.6
Edge 4(Left)	GPRS-2 slot	190	836.6	0.02	0.251	28.95	28.69	0.266	1.6
SIM 2Card									
Right Cheek	GPRS-2 slot	190	836.6	-0.23	0.442	28.95	28.67	0.471	1.6
Body back	GPRS-2 slot	190	836.6	-1.32	0.714	28.95	28.67	0.762	1.6

Note:

- When the 1-g Reported SAR is ≤ 0.8 W/kg, testing for low and high channel is optional. Refer to KDB 447498.
- The test separation for body back and body front is 5mm of all above table.
- The test separation for 4 Edges is 10mm of all above table.

SAR MEASUREMENT									
Depth of Liquid (cm):>15					Relative Humidity (%): 55.4				
Product: Rugged Mobile Phone									
Test Mode: PCS1900 with GMSK modulation									
Position	Mode	Ch.	Fr. (MHz)	Power Drift (<±5%)	SAR (1g) (W/kg)	Max. Tune-up Power (dBm)	Meas. output Power (dBm)	Scaled SAR (W/Kg)	Limit (W/kg)
SIM 1 Card									
Left Cheek	voice	661	1880.0	-0.23	0.413	27.63	27.35	0.441	1.6
Left Tilt	voice	661	1880.0	1.66	0.079	27.63	27.35	0.084	1.6
Right Cheek	voice	661	1880.0	0.23	0.270	27.63	27.35	0.288	1.6
Right Tilt	voice	661	1880.0	-0.12	0.082	27.63	27.35	0.087	1.6
Body back	voice	512	1850.2	0.59	0.704	27.63	27.48	0.729	1.6
Body back	voice	661	1880.0	0.96	0.769	27.63	27.35	0.820	1.6
Body back	voice	810	1909.8	-0.23	0.694	27.63	27.63	0.694	1.6
Body front	voice	661	1880.0	0.63	0.683	27.63	27.35	0.728	1.6
SIM 2 Card									
Left Cheek	GPRS-2 slot	661	1880.0	-0.63	0.638	24.81	24.55	0.677	1.6
Left Tilt	GPRS-2 slot	661	1880.0	1.26	0.111	24.81	24.55	0.118	1.6
Right Cheek	GPRS-2 slot	661	1880.0	-0.33	0.355	24.81	24.55	0.377	1.6
Right Tilt	GPRS-2 slot	661	1880.0	-1.65	0.120	24.81	24.55	0.127	1.6
Body back	GPRS-2 slot	512	1850.2	0.31	0.970	24.81	24.81	0.970	1.6
Body back	GPRS-2 slot	661	1880.0	0.06	0.982	24.81	24.55	1.043	1.6
Body back	GPRS-2 slot	810	1909.8	-0.25	0.953	24.81	24.67	0.984	1.6
Body front	GPRS-2 slot	512	1850.2	0.62	1.026	24.81	24.81	1.026	1.6
Body front	GPRS-2 slot	661	1880.0	0.33	0.977	24.81	24.55	1.037	1.6
Body front	GPRS-2 slot	810	1909.8	0.66	0.888	24.81	24.67	0.917	1.6
Edge 1 (Top)	GPRS-2 slot	661	1880.0	-0.95	0.064	24.81	24.55	0.068	1.6
Edge 2(Right)	GPRS-2 slot	661	1880.0	0.33	0.126	24.81	24.55	0.134	1.6
Edge 3(Bottom)	GPRS-2 slot	512	1850.2	0.66	0.797	24.81	24.81	0.797	1.6
Edge 3(Bottom)	GPRS-2 slot	661	1880.0	-0.36	0.792	24.81	24.55	0.841	1.6
Edge 3(Bottom)	GPRS-2 slot	810	1909.8	-0.61	0.758	24.81	24.67	0.783	1.6
Edge 4(Left)	GPRS-2 slot	661	1880.0	0.32	0.217	24.81	24.55	0.230	1.6
SIM 2 Card									
Left Cheek	GPRS-2 slot	661	1880.0	0.63	0.571	24.81	24.51	0.612	1.6
Body front	GPRS-2 slot	512	1850.2	-0.13	1.018	24.81	24.80	1.020	1.6

Note:

- When the 1-g Reported SAR is ≤ 0.8 W/kg, testing for low and high channel is optional. Refer to KDB 447498.
- The test separation for body back and body front is 5mm of all above table.
- The test separation for 4 Edges is 10mm of all above table.

SAR MEASUREMENT									
Depth of Liquid (cm):>15					Relative Humidity (%): 55.4				
Product: Rugged Mobile Phone									
Test Mode: WCDMA Band II with QPSK modulation									
Position	Mode	Ch.	Fr. (MHz)	Power Drift (<±5%)	SAR (1g) (W/kg)	Max. Tune-up Power (dBm)	Meas. output Power (dBm)	Scaled SAR (W/Kg)	Limit (W/kg)
Left Cheek	RMC 12.2kbps	9400	1880	0.73	0.481	21.82	21.65	0.500	1.6
Left Tilt	RMC 12.2kbps	9400	1880	-1.80	0.073	21.82	21.65	0.076	1.6
Right Cheek	RMC 12.2kbps	9400	1880	0.53	0.111	21.82	21.65	0.115	1.6
Right Tilt	RMC 12.2kbps	9400	1880	-1.23	0.065	21.82	21.65	0.068	1.6
Body back	RMC 12.2kbps	9262	1852.4	-0.62	1.075	21.82	21.82	1.075	1.6
Body back	RMC 12.2kbps	9400	1880	-1.33	1.035	21.82	21.65	1.076	1.6
Body back	RMC 12.2kbps	9538	1907.6	0.92	0.864	21.82	21.53	0.924	1.6
Body front	RMC 12.2kbps	9262	1852.4	0.63	1.144	21.82	21.82	1.144	1.6
Body front	RMC 12.2kbps	9400	1880	-1.33	0.885	21.82	21.65	0.920	1.6
Body front	RMC 12.2kbps	9538	1907.6	-0.63	0.758	21.82	21.53	0.810	1.6
Edge 1 (Top)	RMC 12.2kbps	9400	1880	-1.35	0.085	21.82	21.65	0.088	1.6
Edge 2(Right)	RMC 12.2kbps	9400	1880	-0.63	0.068	21.82	21.65	0.071	1.6
Edge 3(Bottom)	RMC 12.2kbps	9400	1880	1.36	0.615	21.82	21.65	0.640	1.6
Edge 4(Left)	RMC 12.2kbps	9400	1880	-0.13	0.162	21.82	21.65	0.168	1.6

Note:

- When the 1-g Reported SAR is ≤ 0.8 W/kg, testing for low and high channel is optional. Refer to KDB 447498.
- The test separation for body back and body front is 5mm of all above table.
- The test separation for 4 Edges is 10mm of all above table.

SAR MEASUREMENT									
Depth of Liquid (cm):>15					Relative Humidity (%):				
Product: Rugged Mobile Phone									
Test Mode: WCDMA Band IV with QPSK modulation									
Position	Mode	Ch.	Fr. (MHz)	Power Drift ($\pm 5\%$)	SAR (1g) (W/kg)	Max. Tune-up Power (dBm)	Meas. output Power (dBm)	Scaled SAR (W/Kg)	Limit (W/kg)
Left Cheek	RMC 12.2kbps	8662	1732.5	0.53	0.169	20.77	20.62	0.175	1.6
Left Tilt	RMC 12.2kbps	8662	1732.5	1.23	0.029	20.77	20.62	0.030	1.6
Right Cheek	RMC 12.2kbps	8662	1732.5	0.62	0.080	20.77	20.62	0.083	1.6
Right Tilt	RMC 12.2kbps	8662	1732.5	1.35	0.030	20.77	20.62	0.031	1.6
Body back	RMC 12.2kbps	8662	1732.5	0.62	0.420	20.77	20.62	0.435	1.6
Body front	RMC 12.2kbps	8662	1732.5	0.36	0.323	20.77	20.62	0.334	1.6
Edge 1 (Top)	RMC 12.2kbps	8662	1732.5	0.12	0.016	20.77	20.62	0.017	1.6
Edge 2(Right)	RMC 12.2kbps	8662	1732.5	1.56	0.035	20.77	20.62	0.036	1.6
Edge 3(Bottom)	RMC 12.2kbps	8662	1732.5	0.03	0.292	20.77	20.62	0.302	1.6
Edge 4(Left)	RMC 12.2kbps	8662	1732.5	1.24	0.076	20.77	20.62	0.079	1.6

Note:

- When the 1-g Reported SAR is ≤ 0.8 W/kg, testing for low and high channel is optional. Refer to KDB 447498.
- The test separation for body back and body front is 5mm of all above table.
- The test separation for 4 Edges is 10mm of all above table.

SAR MEASUREMENT									
Depth of Liquid (cm):>15					Relative Humidity (%): 50.8				
Product: Rugged Mobile Phone									
Test Mode: WCDMA Band V with QPSK modulation									
Position	Mode	Ch.	Fr. (MHz)	Power Drift ($\pm 5\%$)	SAR (1g) (W/kg)	Max. Tune-up Power (dBm)	Meas. output Power (dBm)	Scaled SAR (W/Kg)	Limit (W/kg)
Left Cheek	RMC 12.2kbps	4183	836.6	-0.36	0.226	20.74	20.39	0.245	1.6
Left Tilt	RMC 12.2kbps	4183	836.6	0.95	0.163	20.74	20.39	0.177	1.6
Right Cheek	RMC 12.2kbps	4183	836.6	1.74	0.234	20.74	20.39	0.254	1.6
Right Tilt	RMC 12.2kbps	4183	836.6	-0.26	0.166	20.74	20.39	0.180	1.6
Body back	RMC 12.2kbps	4183	836.6	0.35	0.473	20.74	20.39	0.513	1.6
Body front	RMC 12.2kbps	4183	836.6	0.63	0.328	20.74	20.39	0.356	1.6
Edge 1 (Top)	RMC 12.2kbps	4183	836.6	-0.01	0.004	20.74	20.39	0.004	1.6
Edge 2(Right)	RMC 12.2kbps	4183	836.6	0.23	0.177	20.74	20.39	0.192	1.6
Edge 3(Bottom)	RMC 12.2kbps	4183	836.6	0.53	0.011	20.74	20.39	0.012	1.6
Edge 4(Left)	RMC 12.2kbps	4183	836.6	-0.20	0.116	20.74	20.39	0.126	1.6

Note:

- When the 1-g Reported SAR is ≤ 0.8 W/kg, testing for low and high channel is optional. Refer to KDB 447498.
- The test separation for body back and body front is 5mm of all above table.
- The test separation for 4 Edges is 10mm of all above table.

SAR MEASUREMENT												
Depth of Liquid (cm):>15						Relative Humidity (%): 55.4						
Product: Rugged Mobile Phone												
Test Mode: LTE Band II												
BW MHz	MOD	Position	Test Mode		Ch.	Freq. (MHz)	Power Drift (<±5%)	SAR (1g) (W/kg)	Max. Tune up Power (dBm)	Meas. output Power (dBm)	Scaled SAR (W/Kg)	Limit (W/kg)
			UL RB Allocation	UL RB START								
20	QPSK	Left Cheek	1	50	19100	1900	-0.23	0.318	23.00	22.75	0.337	1.6
		Left Tilt	1	50	19100	1900	1.66	0.087	23.00	22.75	0.092	1.6
		Right Cheek	1	50	19100	1900	-0.32	0.248	23.00	22.75	0.263	1.6
		Right Tilt	1	50	19100	1900	0.54	0.084	23.00	22.75	0.089	1.6
		Body back	1	50	19100	1900	0.23	0.749	23.00	22.75	0.793	1.6
		Body front	1	50	19100	1900	1.33	0.521	23.00	22.75	0.552	1.6
		Edge 1 (Top)	1	50	19100	1900	0.02	0.052	23.00	22.75	0.055	1.6
		Edge 2(Right)	1	50	19100	1900	-0.21	0.092	23.00	22.75	0.097	1.6
		Edge 3(Bottom)	1	50	19100	1900	0.23	0.388	23.00	22.75	0.411	1.6
		Edge 4(Left)	1	50	19100	1900	-1.33	0.175	23.00	22.75	0.185	1.6

Note:

- When the 1-g Reported SAR is ≤ 0.8 W/kg, testing for low and high channel is optional. Refer to KDB 447498.
- The test separation for body back and body front is 5mm of all above table.
- The test separation for 4 Edges is 10mm of all above table.

SAR MEASUREMENT												
Depth of Liquid (cm):>15						Relative Humidity (%): 52.9						
Product: Rugged Mobile Phone												
Test Mode: LTE Band IV												
BM MHz	MOD	Position	Test Mode		Ch.	Freq. (MHz)	Power Drift (<±5%)	SAR (1g) (W/kg)	Max. Tuneup Power (dBm)	Meas. output Power (dBm)	Scaled SAR (W/Kg)	Limit (W/kg)
			UL RB Allocation	UL RB START								
20	QPSK	Left Cheek	1	0	20175	1732.5	-0.23	0.196	23.00	22.73	0.209	1.6
		Left Tilt	1	0	20175	1732.5	1.55	0.039	23.00	22.73	0.042	1.6
		Right Cheek	1	0	20175	1732.5	0.02	0.140	23.00	22.73	0.149	1.6
		Right Tilt	1	0	20175	1732.5	-0.23	0.040	23.00	22.73	0.043	1.6
		Body back	1	0	20175	1732.5	0.63	0.469	23.00	22.73	0.499	1.6
		Body front	1	0	20175	1732.5	0.23	0.464	23.00	22.73	0.494	1.6
		Edge 1 (Top)	1	0	20175	1732.5	-1.33	0.007	23.00	22.73	0.007	1.6
		Edge 2(Right)	1	0	20175	1732.5	0.02	0.004	23.00	22.73	0.004	1.6
		Edge 3(Bottom)	1	0	20175	1732.5	0.23	0.386	23.00	22.73	0.411	1.6
		Edge 4(Left)	1	0	20175	1732.5	-1.02	0.097	23.00	22.73	0.103	1.6

Note:

- When the 1-g Reported SAR is ≤ 0.8 W/kg, testing for low and high channel is optional. Refer to KDB 447498.
- The test separation for body back and body front is 5mm of all above table.
- The test separation for 4 Edges is 10mm of all above table.

SAR MEASUREMENT												
Depth of Liquid (cm):>15						Relative Humidity (%):50.8						
Product: Rugged Mobile Phone												
Test Mode: LTE Band V												
BM MHz	MOD	Position	Test Mode		Ch.	Freq. (MHz)	Power Drift (<±5%)	SAR (1g) (W/kg)	Max. Tuneup Power (dBm)	Meas. output Power (dBm)	Scaled SAR (W/Kg)	Limit (W/kg)
			UL RB Allocation	UL RB START								
10	QPSK	Left Cheek	1	0	20525	836.5	0.23	0.352	23.00	22.07	0.436	1.6
		Left Tilt	1	0	20525	836.5	-1.33	0.227	23.00	22.07	0.281	1.6
		Right Cheek	1	0	20525	836.5	0.30	0.392	23.00	22.07	0.486	1.6
		Right Tilt	1	0	20525	836.5	0.63	0.289	23.00	22.07	0.358	1.6
		Body back	1	0	20525	836.5	-1.03	0.620	23.00	22.07	0.768	1.6
		Body front	1	0	20525	836.5	0.22	0.441	23.00	22.07	0.546	1.6
		Edge 1 (Top)	1	0	20525	836.5	0.13	0.027	23.00	22.07	0.033	1.6
		Edge 2(Right)	1	0	20525	836.5	-1.22	0.275	23.00	22.07	0.341	1.6
		Edge 3(Bottom)	1	0	20525	836.5	0.02	0.120	23.00	22.07	0.149	1.6
		Edge 4(Left)	1	0	20525	836.5	-0.23	0.220	23.00	22.07	0.273	1.6

Note:

- When the 1-g Reported SAR is ≤ 0.8 W/kg, testing for low and high channel is optional. Refer to KDB 447498.
- The test separation for body back and body front is 5mm of all above table.
- The test separation for 4 Edges is 10mm of all above table.

SAR MEASUREMENT												
Depth of Liquid (cm):>15						Relative Humidity (%): 51.3						
Product: Rugged Mobile Phone												
Test Mode: LTE Band VII												
BM MHz	MOD	Position	Test Mode		Ch.	Freq. (MHz)	Power Drift (<±5%)	SAR (1g) (W/kg)	Max. Tuneup Power (dBm)	Meas. output Power (dBm)	Scaled SAR (W/Kg)	Limit (W/kg)
			UL RB Allocation	UL RB START								
20	QPSK	Left Cheek	1	0	21100	2535	-0.23	0.352	22.94	22.34	0.404	1.6
		Left Tilt	1	0	21100	2535	1.33	0.062	22.94	22.34	0.071	1.6
		Right Cheek	1	0	21100	2535	0.02	0.231	22.94	22.34	0.265	1.6
		Right Tilt	1	0	21100	2535	-0.35	0.053	22.94	22.34	0.061	1.6
		Body back	1	0	21100	2535	0.25	0.696	22.94	22.34	0.799	1.6
		Body front	1	0	21100	2535	0.23	0.694	22.94	22.34	0.797	1.6
		Edge 1 (Top)	1	0	21100	2535	-1.33	0.034	22.94	22.34	0.039	1.6
		Edge 2(Right)	1	0	21100	2535	0.02	0.095	22.94	22.34	0.109	1.6
		Edge 3(Bottom)	1	0	21100	2535	-1.33	0.397	22.94	22.34	0.456	1.6
		Edge 4(Left)	1	0	21100	2535	0.21	0.152	22.94	22.34	0.175	1.6

Note:

- When the 1-g Reported SAR is ≤ 0.8 W/kg, testing for low and high channel is optional. Refer to KDB 447498.
- The test separation for body back and body front is 5mm of all above table.
- The test separation for 4 Edges is 10mm of all above table.

SAR MEASUREMENT												
Depth of Liquid (cm):>15						Relative Humidity (%): 54.6						
Product: Rugged Mobile Phone												
Test Mode: LTE Band XVII												
BM MHz	MOD	Position	Test Mode		Ch.	Freq. (MHz)	Power Drift (<±5%)	SAR (1g) (W/kg)	Max. Tuneup Power (dBm)	Meas. output Power (dBm)	Scaled SAR (W/Kg)	Limit (W/kg)
			UL RB Allocation	UL RB START								
10	QPSK	Left Cheek	1	0	23790	710	-0.23	0.051	23.00	22.55	0.057	1.6
		Left Tilt	1	0	23790	710	1.33	0.040	23.00	22.55	0.044	1.6
		Right Cheek	1	0	23790	710	-0.02	0.058	23.00	22.55	0.064	1.6
		Right Tilt	1	0	23790	710	0.23	0.050	23.00	22.55	0.055	1.6
		Body back	1	0	23790	710	1.55	0.146	23.00	22.55	0.162	1.6
		Body front	1	0	23790	710	0.32	0.068	23.00	22.55	0.075	1.6
		Edge 1 (Top)	1	0	23790	710	-0.53	0.005	23.00	22.55	0.006	1.6
		Edge 2(Right)	1	0	23790	710	0.23	0.031	23.00	22.55	0.034	1.6
		Edge 3(Bottom)	1	0	23790	710	1.23	0.013	23.00	22.55	0.014	1.6
		Edge 4(Left)	1	0	23790	710	-0.21	0.038	23.00	22.55	0.042	1.6

Note:

- When the 1-g Reported SAR is ≤ 0.8 W/kg, testing for low and high channel is optional. Refer to KDB 447498.
- The test separation for body back and body front is 5mm of all above table.
- The test separation for 4 Edges is 10mm of all above table.

SAR MEASUREMENT									
Depth of Liquid (cm):>15				Relative Humidity (%): 53.6					
Product: Rugged Mobile Phone									
Test Mode:802.11b									
Position	Mode	Ch.	Fr. (MHz)	Power Drift (<±5%)	SAR (1g) (W/kg)	Max. Tune-up Power (dBm)	Meas. output Power (dBm)	Scaled SAR (W/Kg)	Limit (W/kg)
Left Cheek	DTS	6	2437	-0.23	0.655	12.59	12.59	0.655	1.6
Left Tilt	DTS	6	2437	1.33	0.617	12.59	12.59	0.617	1.6
Right Cheek	DTS	6	2437	0.24	0.357	12.59	12.59	0.357	1.6
Right Tilt	DTS	6	2437	-0.23	0.327	12.59	12.59	0.327	1.6
Body back	DTS	6	2437	1.33	0.389	12.59	12.59	0.389	1.6
Body front	DTS	6	2437	-0.52	0.421	12.59	12.59	0.421	1.6
Edge 1 (Top)	DTS	6	2437	0.23	0.084	12.59	12.59	0.084	1.6
Edge 2(Right)	DTS	6	2437	1.66	0.072	12.59	12.59	0.072	1.6
Edge 3(Bottom)	DTS	6	2437	-0.23	0.014	12.59	12.59	0.014	1.6
Edge 4(Left)	DTS	6	2437	-1.35	0.027	12.59	12.59	0.027	1.6

Note:

- According to KDB248227, SAR is not required for 802.11n HT20/HT40 channels when the maximum average output power is less than 1/4 dB higher than that measured on the corresponding 802.11a/b channels.
- All of above "DTS" means data transmitters.
- The test separation for body back and body front is 5mm of all above table.
- The test separation for 4 Edges is 10mm of all above table.

Repeated SAR										
Product: Rugged Mobile Phone										
Test Mode: PCS1900& WCDMA Band II										
Position	Mode	Ch.	Fr. (MHz)	Power Drift (<±5%)	Once SAR (1g) (W/kg)	Power Drift (<±5%)	Twice SAR (1g) (W/kg)	Power Drift (<±5%)	Third SAR (1g) (W/kg)	Limit W/kg
Body front	GPRS-2 slot	512	1850.2	0.02	1.021	--	--	--	--	1.6
Body front	RMC 12.2kbps	9262	1852.4	1.33	1.089	--	--	--	--	1.6

Simultaneous Multi-band Transmission Evaluation:
Application Simultaneous Transmission information:

NO	Simultaneous state	Portable Handset		
		Head	Body-worn	Hotspot
1	GSM(voice)+WLAN 2.4GHz (data)	Yes	Yes	-
2	WCDMA(voice)+WLAN 2.4GHz (data)	Yes	Yes	-
3	GSM(voice)+Bluetooth(data)	-	Yes	-
4	WCDMA(voice)+Bluetooth(data)	-	Yes	-
5	GSM (Data) + Bluetooth(data)	-	Yes	
6	GSM (Data) + WLAN 2.4GHz (data)	Yes	Yes	Yes
7	WCDMA (Data) + Bluetooth(data)	--	Yes	
8	WCDMA (Data) + WLAN 2.4GHz (data)	Yes	Yes	Yes
9	LTE + Bluetooth(data)	--	Yes	
10	LTE + WLAN 2.4GHz (data)	Yes	Yes	Yes

NOTE:

1. WIFI and BT share the same antenna, and cannot transmit simultaneously.
2. Simultaneous with every transmitter must be the same test position.
3. KDB 447498 D01, BT SAR is excluded as below table.
4. KDB 447498 D01, for handsets the test separation distance is determined by the smallest distance between the outer surface of the device and the user; which is 0mm for head SAR and 5mm for body-worn SAR.
5. According to KDB 447498 D01 4.3.1, Standalone SAR test exclusion is as follow:
For 100 MHz to 6 GHz and test separation distances ≤ 50 mm, the 1-g and 10-g SAR test exclusion thresholds are determined by the following:

$$[(\text{max. power of channel, including tune-up tolerance, mW}) / (\text{min. test separation distance, mm})] \cdot [\sqrt{f(\text{GHz})}] \leq 3.0$$
 for 1-g SAR, and ≤ 7.5 for 10-g extremity SAR³⁰, where
 - f(GHz) is the RF channel transmit frequency in GHz
 - Power and distance are rounded to the nearest mW and mm before calculation³¹
 - The result is rounded to one decimal place for comparison
 - The values 3.0 and 7.5 are referred to as numeric thresholds in step b) below
 The test exclusions are applicable only when the minimum test separation distance is ≤ 50 mm, and for transmission frequencies between 100 MHz and 6 GHz. When the minimum test separation distance is < 5 mm, a distance of 5 mm according to 4.1 f) is applied to determine SAR test exclusion.
6. If the test separation distance is < 5 mm, 5mm is used for excluded SAR calculation.
7. According to KDB 447498 D01 4.3.2, simultaneous transmission SAR test exclusion is as follow:
 - (1) Simultaneous transmission SAR test exclusion is determined for each operating configuration and exposure condition according to the reported standalone SAR of each applicable simultaneous transmitting antenna.
 - (2) Any transmitters and antennas should be considered when calculating simultaneous mode.
 - (3) For mobile phone and PC, it's the sum of all transmitters and antennas at the same mode with same position in each applicable exposure condition
 - (4) When the standalone SAR test exclusion of section 4.3.2 is applied to an antenna that transmits simultaneously with other antennas, the standalone SAR must be estimated according to the following to det

$$(\text{max. power of channel, including tune-up tolerance, mW}) / (\text{min. test separation distance, mm}) \cdot [\sqrt{f(\text{GHz})} / x] \text{ W/kg}$$
 for test separation distances ≤ 50 mm;
 where $x = 7.5$ for 1-g SAR, and $x = 18.75$ for 10-g SAR.

8. When the sum of SAR is larger than the limit, SAR test exclusion is determined by the SAR to peak location separation ratio. The simultaneous transmitting antennas in each operating mode and exposure condition combination must be considered one pair at a time to determine the SAR to peak location separation ratio to qualify for test exclusion. The ratio is determined by $(SAR1 + SAR2)1.5/R_i$, rounded to two decimal digits, and must be ≤ 0.04 for all antenna pairs in the configuration to qualify for 1-g SAR test exclusion.

Estimated SAR		Max Power including Tune-up Tolerance		Separation Distance (mm)	Estimated SAR (W/kg)
		dBm	mW		
BT	Head	2	1.585	0	0.067
	Body	2	1.585	5	0.067
				10	0.033

Sum of the SAR for GSM 850 & Wi-Fi & BT:

RF Exposure Conditions	Test Position	Simultaneous Transmission Scenario			Σ1-g SAR (W/Kg)	SPLSR (Yes/No)
		GSM 850	Wi-Fi DTS Band	Bluetooth		
Head (voice)	Left Touch	0.252	0.655		0.907	No
	Left Tilt	0.158	0.617		0.775	No
	Right Touch	0.285	0.357		0.642	No
	Right Tilt	0.182	0.327		0.509	No
Body-worn (voice)	Rear	0.472	0.389		0.861	No
		0.472		0.067	0.539	No
	Front	0.374	0.421		0.795	No
		0.374		0.067	0.441	No
Head (Data)	Left Touch	0.397	0.084		0.481	No
	Left Tilt	0.281	0.072		0.353	No
	Right Touch	0.477	0.014		0.491	No
	Right Tilt	0.289	0.027		0.316	No
Body-worn (Data)	Rear	0.774		0.067	0.841	No
		0.774	0.389		1.163	No
	Front	0.614		0.067	0.681	No
		0.614	0.421		1.035	No
Body-worn (Hotspot)	Edge 1	0.030	0.084		0.114	No
	Edge 2	0.339	0.072		0.411	No
	Edge 3	0.170	0.014		0.184	No
	Edge 4	0.266	0.027		0.293	No
	Edge 1	0.030		0.033	0.063	No
	Edge 2	0.339		0.033	0.372	No
	Edge 3	0.170		0.033	0.203	No
	Edge 4	0.266		0.033	0.299	No

Note:

·According to KDB 447498 D01 General RF Exposure Guidance, when the simultaneous transmission SAR is less than 1.6 W/Kg, SPLSR assessment is not required.

·SPLSR mean is “The SAR to Peak Location Separation Ratio “

Sum of the SAR for GSM 1900 & Wi-Fi & BT:

RF Exposure Conditions	Test Position	Simultaneous Transmission Scenario			Σ1-g SAR (W/Kg)	SPLSR (Yes/No)
		PCS 1900	Wi-Fi DTS Band	Bluetooth		
Head (voice)	Left Touch	0.441	0.655		1.096	No
	Left Tilt	0.084	0.617		0.701	No
	Right Touch	0.288	0.357		0.645	No
	Right Tilt	0.087	0.327		0.414	No
Body-worn (voice)	Rear	0.820	0.389		1.209	No
		0.820		0.067	0.887	No
	Front	0.728	0.421		1.149	No
		0.728		0.067	0.795	No
Head (Data)	Left Touch	0.677	0.084		0.761	No
	Left Tilt	0.118	0.072		0.190	No
	Right Touch	0.377	0.014		0.391	No
	Right Tilt	0.127	0.027		0.154	No
Body-worn (Data)	Rear	1.043		0.067	1.110	No
		1.043	0.389		1.432	No
	Front	1.037		0.067	1.104	No
		1.037	0.421		1.458	No
Body-worn (Hotspot)	Edge 1	0.068	0.084		0.152	No
	Edge 2	0.134	0.072		0.206	No
	Edge 3	0.841	0.014		0.855	No
	Edge 4	0.230	0.027		0.257	No
	Edge 1	0.068		0.033	0.101	No
	Edge 2	0.134		0.033	0.167	No
	Edge 3	0.841		0.033	0.874	No
	Edge 4	0.230		0.033	0.263	No

Note:

- According to KDB 447498 D01 General RF Exposure Guidance, when the simultaneous transmission SAR is less than 1.6 W/Kg, SPLSR assessment is not required.
- SPLSR mean is “The SAR to Peak Location Separation Ratio “

Sum of the SAR for WCDMA Band II & Wi-Fi & BT:

RF Exposure Conditions	Test Position	Simultaneous Transmission Scenario			Σ 1-g SAR (W/Kg)	SPLSR (Yes/No)
		WCDMA Band II	Wi-Fi DTS Band	Bluetooth		
Head	Left Touch	0.500	0.655		1.155	No
	Left Tilt	0.076	0.617		0.693	No
	Right Touch	0.115	0.357		0.472	No
	Right Tilt	0.068	0.327		0.395	No
Body-worn	Rear	1.076	0.389		1.465	No
	Front	1.144	0.421		1.565	No
	Edge 1	0.088	0.084		0.172	No
	Edge 2	0.071	0.072		0.143	No
	Edge 3	0.640	0.014		0.654	No
	Edge 4	0.168	0.027		0.195	No
	Rear	1.076		0.067	1.143	No
	Front	1.144		0.067	1.211	No
	Edge 1	0.088		0.033	0.121	No
	Edge 2	0.071		0.033	0.104	No
	Edge 3	0.640		0.033	0.673	No
	Edge 4	0.168		0.033	0.201	No

Note:

- According to KDB 447498 D01 General RF Exposure Guidance, when the simultaneous transmission SAR is less than 1.6 W/Kg, SPLSR assessment is not required.
- SPLSR mean is “The SAR to Peak Location Separation Ratio “

Sum of the SAR for WCDMA Band IV & Wi-Fi & BT:

RF Exposure Conditions	Test Position	Simultaneous Transmission Scenario			Σ1-g SAR (W/Kg)	SPLSR (Yes/No)
		WCDMA Band IV	Wi-Fi DTS Band	Bluetooth		
Head	Left Touch	0.175	0.655		0.830	No
	Left Tilt	0.030	0.617		0.647	No
	Right Touch	0.083	0.357		0.440	No
	Right Tilt	0.031	0.327		0.358	No
Body-worn	Rear	0.435	0.389		0.824	No
	Front	0.334	0.421		0.755	No
	Edge 1	0.017	0.084		0.101	No
	Edge 2	0.036	0.072		0.108	No
	Edge 3	0.302	0.014		0.316	No
	Edge 4	0.079	0.027		0.106	No
	Rear	0.435		0.067	0.502	No
	Front	0.334		0.067	0.401	No
	Edge 1	0.017		0.033	0.050	No
	Edge 2	0.036		0.033	0.069	No
	Edge 3	0.302		0.033	0.335	No
	Edge 4	0.079		0.033	0.112	No

Note:

- According to KDB 447498 D01 General RF Exposure Guidance, when the simultaneous transmission SAR is less than 1.6 W/Kg, SPLSR assessment is not required.
- SPLSR mean is “The SAR to Peak Location Separation Ratio “

Sum of the SAR for WCDMA Band V & Wi-Fi & BT:

RF Exposure Conditions	Test Position	Simultaneous Transmission Scenario			Σ 1-g SAR (W/Kg)	SPLSR (Yes/No)
		WCDMA Band V	Wi-Fi DTS Band	Bluetooth		
Head	Left Touch	0.245	0.655		0.900	No
	Left Tilt	0.177	0.617		0.794	No
	Right Touch	0.254	0.357		0.611	No
	Right Tilt	0.180	0.327		0.507	No
Body-worn	Rear	0.513	0.389		0.902	No
	Front	0.356	0.421		0.777	No
	Edge 1	0.004	0.084		0.088	No
	Edge 2	0.192	0.072		0.264	No
	Edge 3	0.012	0.014		0.026	No
	Edge 4	0.126	0.027		0.153	No
	Rear	0.513		0.067	0.580	No
	Front	0.356		0.067	0.423	No
	Edge 1	0.004		0.033	0.037	No
	Edge 2	0.192		0.033	0.225	No
	Edge 3	0.012		0.033	0.045	No
	Edge 4	0.126		0.033	0.159	No

Note:

- According to KDB 447498 D01 General RF Exposure Guidance, when the simultaneous transmission SAR is less than 1.6 W/Kg, SPLSR assessment is not required.
- SPLSR mean is "The SAR to Peak Location Separation Ratio "

Sum of the SAR for LTE Band II &Wi-Fi & BT:

RF Exposure Conditions	Test Position	Simultaneous Transmission Scenario			Σ1-g SAR (W/Kg)	SPLSR (Yes/No)
		LTE Band II	Wi-Fi DTS Band	Bluetooth		
Head	Left Touch	0.337	0.655		0.992	No
	Left Tilt	0.092	0.617		0.709	No
	Right Touch	0.263	0.357		0.620	No
	Right Tilt	0.089	0.327		0.416	No
Body-worn	Rear	0.793	0.389		1.182	No
	Front	0.552	0.421		0.973	No
	Edge 1	0.055	0.084		0.139	No
	Edge 2	0.097	0.072		0.169	No
	Edge 3	0.411	0.014		0.425	No
	Edge 4	0.185	0.027		0.212	No
	Rear	0.793		0.067	0.860	No
	Front	0.552		0.067	0.619	No
	Edge 1	0.055		0.033	0.088	No
	Edge 2	0.097		0.033	0.130	No
	Edge 3	0.411		0.033	0.444	No
	Edge 4	0.185		0.033	0.218	No

Sum of the SAR for LTE Band IV &Wi-Fi & BT:

RF Exposure Conditions	Test Position	Simultaneous Transmission Scenario			Σ1-g SAR (W/Kg)	SPLSR (Yes/No)
		LTE Band IV	Wi-Fi DTS Band	Bluetooth		
Head	Left Touch	0.209	0.655		0.864	No
	Left Tilt	0.042	0.617		0.659	No
	Right Touch	0.149	0.357		0.506	No
	Right Tilt	0.043	0.327		0.370	No
Body-worn	Rear	0.499	0.389		0.888	No
	Front	0.494	0.421		0.915	No
	Edge 1	0.007	0.084		0.091	No
	Edge 2	0.004	0.072		0.076	No
	Edge 3	0.411	0.014		0.425	No
	Edge 4	0.103	0.027		0.130	No
	Rear	0.499		0.067	0.566	No
	Front	0.494		0.067	0.561	No
	Edge 1	0.007		0.033	0.040	No
	Edge 2	0.004		0.033	0.037	No
	Edge 3	0.411		0.033	0.444	No
	Edge 4	0.103		0.033	0.136	No

Note:

- According to KDB 447498 D01 General RF Exposure Guidance, when the simultaneous transmission SAR is less than 1.6 W/Kg, SPLSR assessment is not required.
- SPLSR mean is “The SAR to Peak Location Separation Ratio “

Sum of the SAR for LTE Band V & Wi-Fi & BT:

RF Exposure Conditions	Test Position	Simultaneous Transmission Scenario			Σ1-g SAR (W/Kg)	SPLSR (Yes/No)
		LTE Band V	Wi-Fi DTS Band	Bluetooth		
Head	Left Touch	0.436	0.655		1.091	No
	Left Tilt	0.281	0.617		0.898	No
	Right Touch	0.486	0.357		0.843	No
	Right Tilt	0.358	0.327		0.685	No
Body-worn	Rear	0.768	0.389		1.157	No
	Front	0.546	0.421		0.967	No
	Edge 1	0.033	0.084		0.117	No
	Edge 2	0.341	0.072		0.413	No
	Edge 3	0.149	0.014		0.163	No
	Edge 4	0.273	0.027		0.300	No
	Rear	0.768		0.067	0.835	No
	Front	0.546		0.067	0.613	No
	Edge 1	0.033		0.033	0.066	No
	Edge 2	0.341		0.033	0.374	No
	Edge 3	0.149		0.033	0.182	No
	Edge 4	0.273		0.033	0.306	No

Sum of the SAR for LTE Band VII & Wi-Fi & BT:

RF Exposure Conditions	Test Position	Simultaneous Transmission Scenario			Σ1-g SAR (W/Kg)	SPLSR (Yes/No)
		LTE Band VII	Wi-Fi DTS Band	Bluetooth		
Head	Left Touch	0.404	0.655		1.059	No
	Left Tilt	0.071	0.617		0.688	No
	Right Touch	0.265	0.357		0.622	No
	Right Tilt	0.061	0.327		0.388	No
Body-worn	Rear	0.799	0.389		1.188	No
	Front	0.797	0.421		1.218	No
	Edge 1	0.039	0.084		0.123	No
	Edge 2	0.109	0.072		0.181	No
	Edge 3	0.456	0.014		0.470	No
	Edge 4	0.175	0.027		0.202	No
	Rear	0.799		0.067	0.866	No
	Front	0.797		0.067	0.864	No
	Edge 1	0.039		0.033	0.072	No
	Edge 2	0.109		0.033	0.142	No
	Edge 3	0.456		0.033	0.489	No
	Edge 4	0.175		0.033	0.208	No

Note:

- According to KDB 447498 D01 General RF Exposure Guidance, when the simultaneous transmission SAR is less than 1.6 W/Kg, SPLSR assessment is not required.
- SPLSR mean is "The SAR to Peak Location Separation Ratio "

Sum of the SAR for LTE Band XVII & Wi-Fi & BT:

RF Exposure Conditions	Test Position	Simultaneous Transmission Scenario			Σ1-g SAR (W/Kg)	SPLSR (Yes/No)
		LTE Band XVII	Wi-Fi DTS Band	Bluetooth		
Head	Left Touch	0.057	0.655		0.712	No
	Left Tilt	0.044	0.617		0.661	No
	Right Touch	0.064	0.357		0.421	No
	Right Tilt	0.055	0.327		0.382	No
Body-worn	Rear	0.162	0.389		0.551	No
	Front	0.075	0.421		0.496	No
	Edge 1	0.006	0.084		0.090	No
	Edge 2	0.034	0.072		0.106	No
	Edge 3	0.014	0.014		0.028	No
	Edge 4	0.042	0.027		0.069	No
	Rear	0.162		0.067	0.229	No
	Front	0.075		0.067	0.142	No
	Edge 1	0.006		0.033	0.039	No
	Edge 2	0.034		0.033	0.067	No
	Edge 3	0.014		0.033	0.047	No
	Edge 4	0.042		0.033	0.075	No

Note:

- According to KDB 447498 D01 General RF Exposure Guidance, when the simultaneous transmission SAR is less than 1.6 W/Kg, SPLSR assessment is not required.
- SPLSR mean is “The SAR to Peak Location Separation Ratio “

APPENDIX A. SAR SYSTEM CHECK DATA

Test Laboratory: AGC Lab

Date: July 04,2017

System Check Head 750 MHz

DUT: Dipole 750 MHz Type: SID 750

Communication System CW; Communication System Band: D750 (750.0 MHz); Duty Cycle: 1:1; Conv.F=5.11

Frequency: 750 MHz; Medium parameters used: $f = 750$ MHz; $\zeta = 0.91$ mho/m; $\epsilon_r = 41.25$; $\rho = 1000$ kg/m³ ;

Phantom section: Flat Section; Input Power=18dBm

Ambient temperature (°C):22.3, Liquid temperature (°C): 21.6

SATIMO Configuration:

- Probe: SSE5; Calibrated: 12/05/2016; Serial No.: SN 14/16 EP308
- Sensor-Surface: 4mm (Mechanical Surface Detection)
- Phantom: SAM twin phantom
- Measurement SW: OpenSAR V4_02_32

Configuration/System Check 750MHz Head/Area Scan: Measurement grid: dx=8mm, dy=8mm

Configuration/System Check 750MHz Head/Zoom Scan: Measurement grid: dx=8mm,dy=8mm, dz=5mm

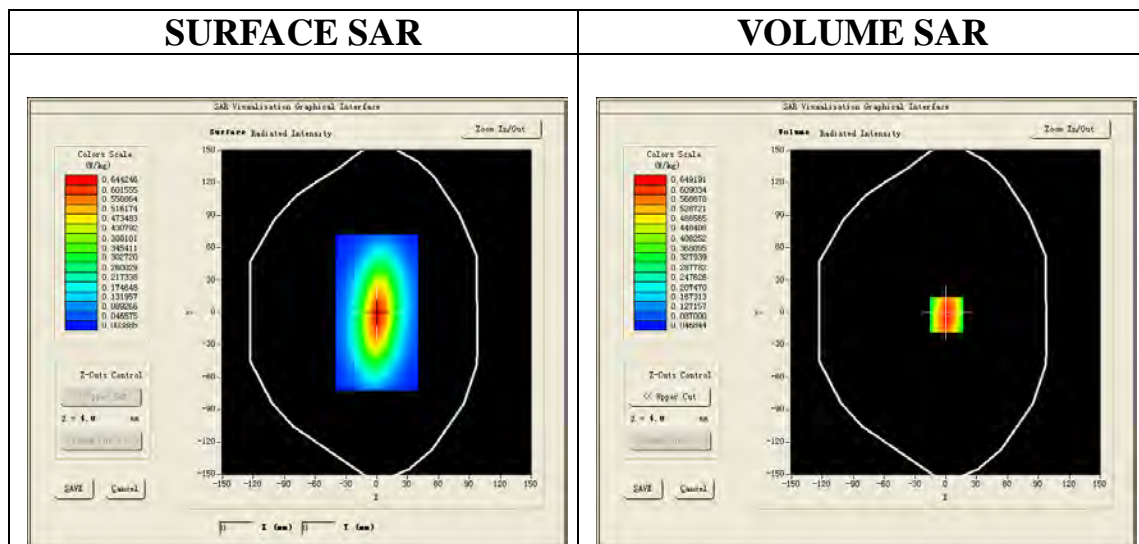

Maximum location: X=1.00, Y=-2.00

SAR Peak: 0.94 W/kg

SAR 10g (W/Kg)	0.381529
SAR 1g (W/Kg)	0.575762

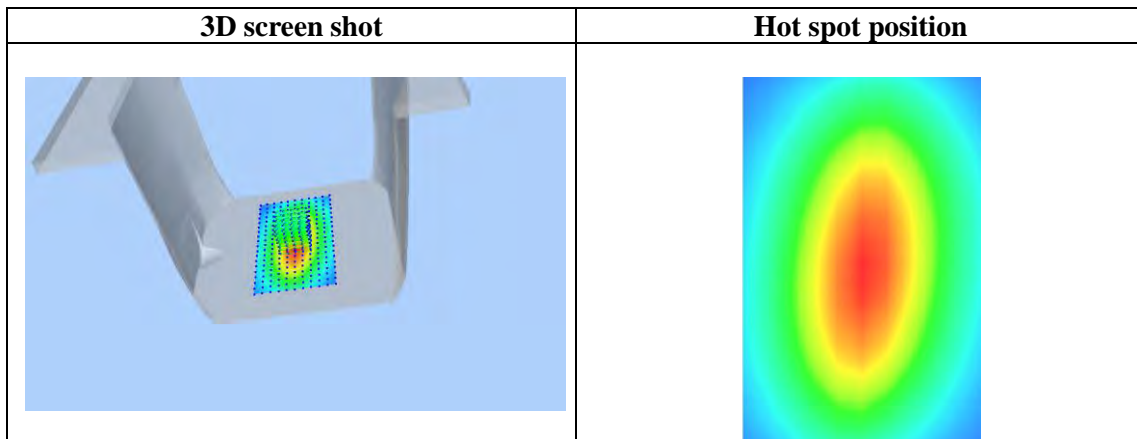
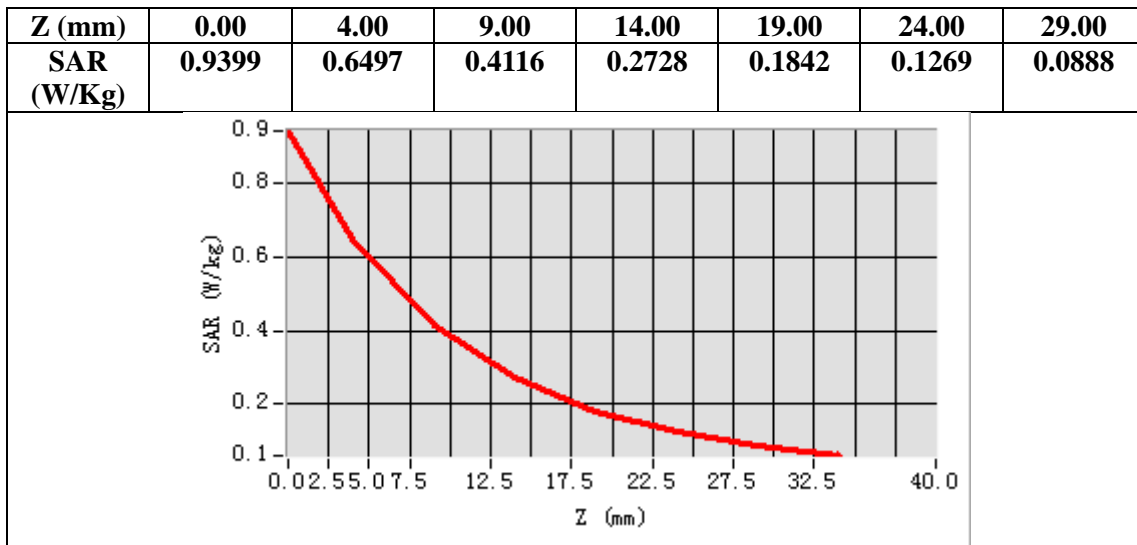

Test Laboratory: AGC Lab
System Check Body 750 MHz

Date: July 04,2017

DUT: Dipole 750 MHz Type: SID 750

Communication System CW; Communication System Band: D750 (750.0 MHz); Duty Cycle: 1:1; Conv.F=5.30
Frequency: 750 MHz; Medium parameters used: $f = 750$ MHz; $\zeta = 0.99$ mho/m; $\epsilon_r = 54.63$; $\rho = 1000$ kg/m³ ;
Phantom section: Flat Section; Input Power=18dBm
Ambient temperature (°C):22.3, Liquid temperature (°C): 21.9

SATIMO Configuration:

- Probe: SSE5; Calibrated: 12/05/2016; Serial No.: SN 14/16 EP308
- Sensor-Surface: 4mm (Mechanical Surface Detection)
- Phantom: SAM twin phantom
- Measurement SW: OpenSAR V4_02_32

Configuration/System Check 750MHz Body/Area Scan: Measurement grid: dx=8mm, dy=8mm

Configuration/System Check 750MHz Body/Zoom Scan: Measurement grid: dx=8mm,dy=8mm, dz=5mm

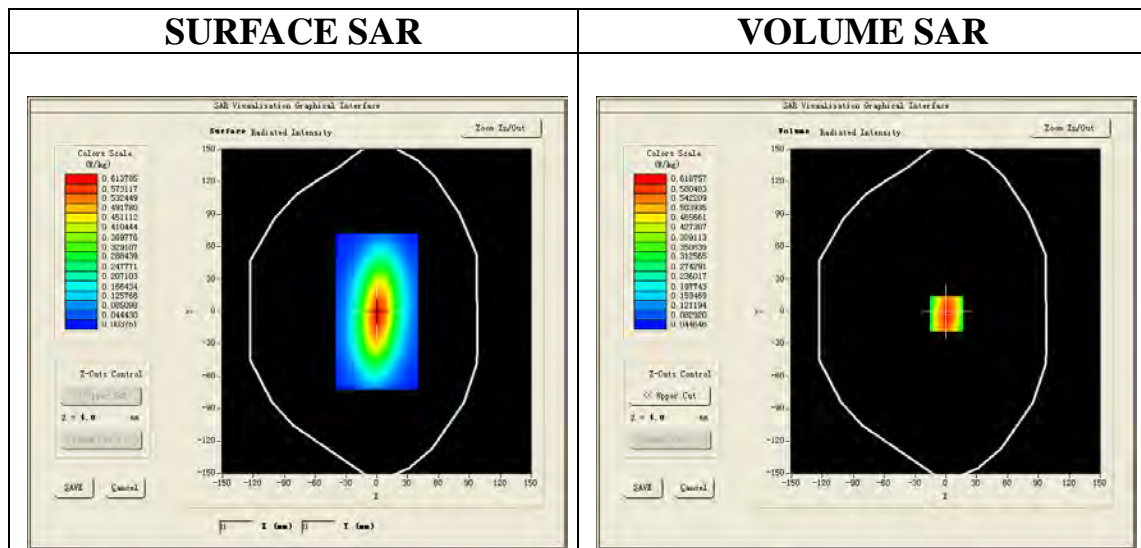

Maximum location: X=1.00, Y=-2.00
SAR Peak: 0.90 W/kg

SAR 10g (W/Kg)	0.365132
SAR 1g (W/Kg)	0.597896

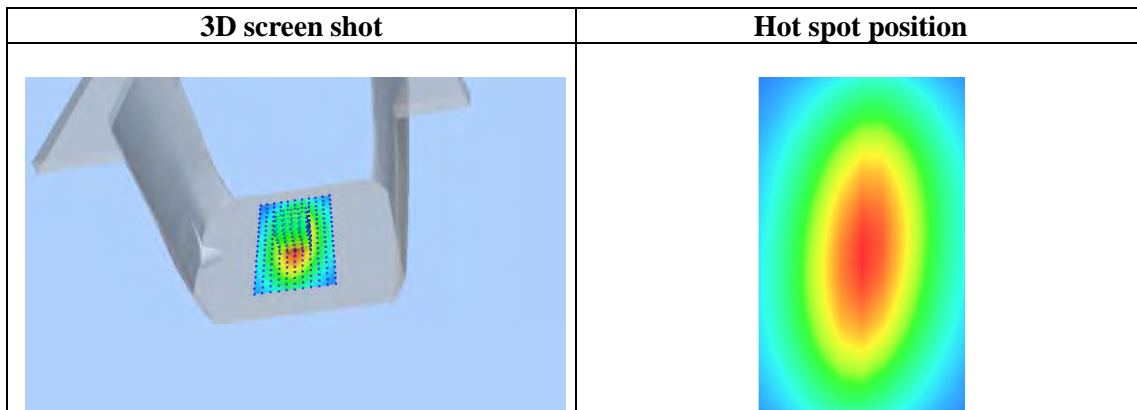
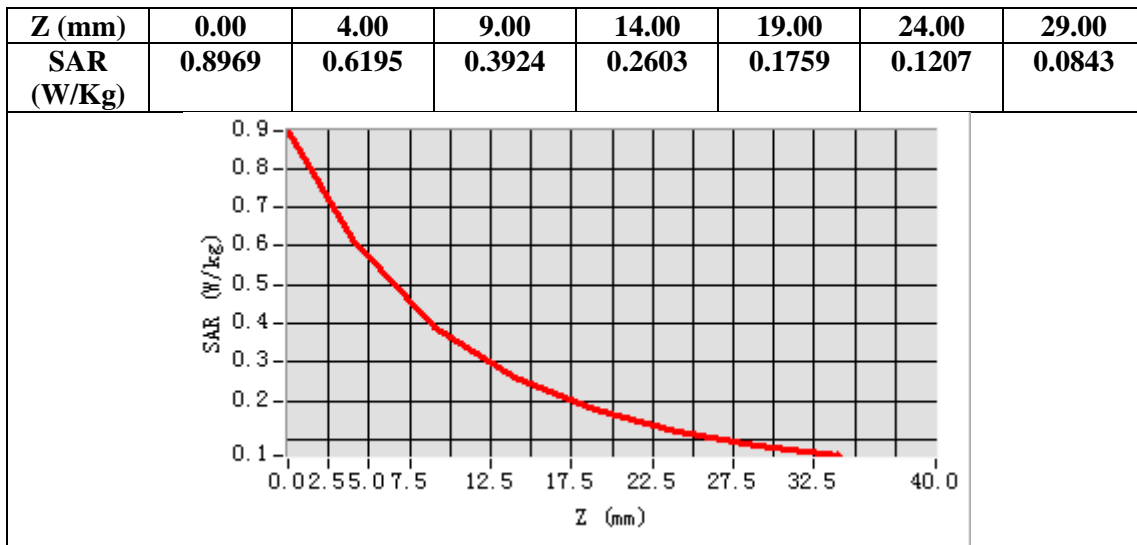

Test Laboratory: AGC Lab
System Check Head 835 MHz

Date: July 02,2017

DUT: Dipole 835 MHz Type: SID 835

Communication System CW; Communication System Band: D835 (835.0 MHz); Duty Cycle: 1:1; Conv.F=5.72
Frequency: 835 MHz; Medium parameters used: $f = 835$ MHz; $\zeta = 0.90$ mho/m; $\epsilon_r = 41.79$; $\rho = 1000$ kg/m³ ;
Phantom section: Flat Section; Input Power=18dBm
Ambient temperature (°C):21.9, Liquid temperature (°C): 21.3

SATIMO Configuration:

- Probe: SSE5; Calibrated: 12/05/2016; Serial No.: SN 14/16 EP308
- Sensor-Surface: 4mm (Mechanical Surface Detection)
- Phantom: SAM twin phantom
- Measurement SW: OpenSAR V4_02_32

Configuration/System Check 835MHz Head/Area Scan: Measurement grid: dx=8mm, dy=8mm

Configuration/System Check 835MHz Head/Zoom Scan: Measurement grid: dx=8mm,dy=8mm, dz=5mm

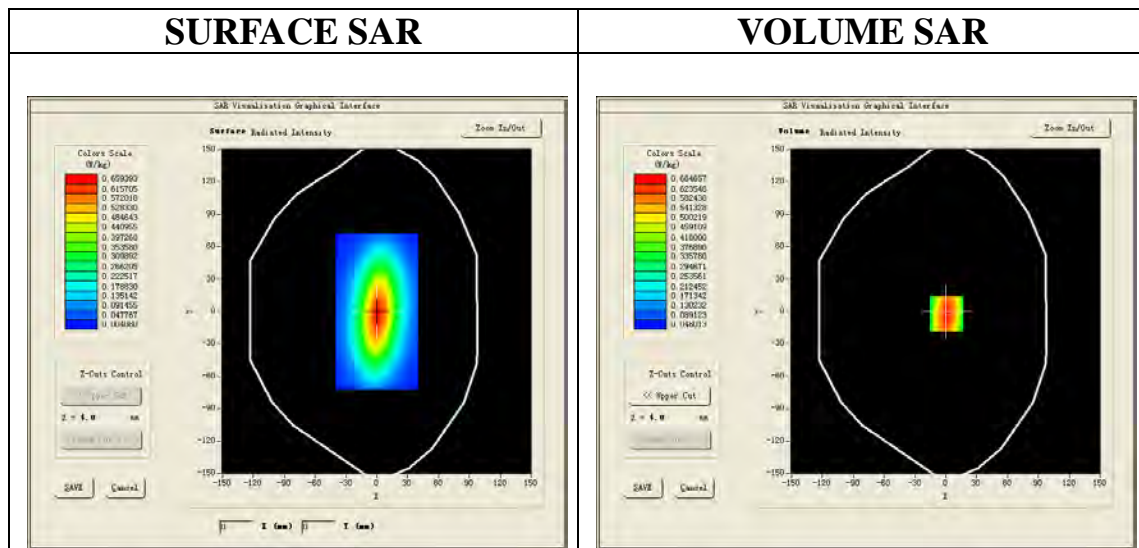

Maximum location: X=1.00, Y=-2.00
SAR Peak: 0.97 W/kg

SAR 10g (W/Kg)	0.390532
SAR 1g (W/Kg)	0.638571

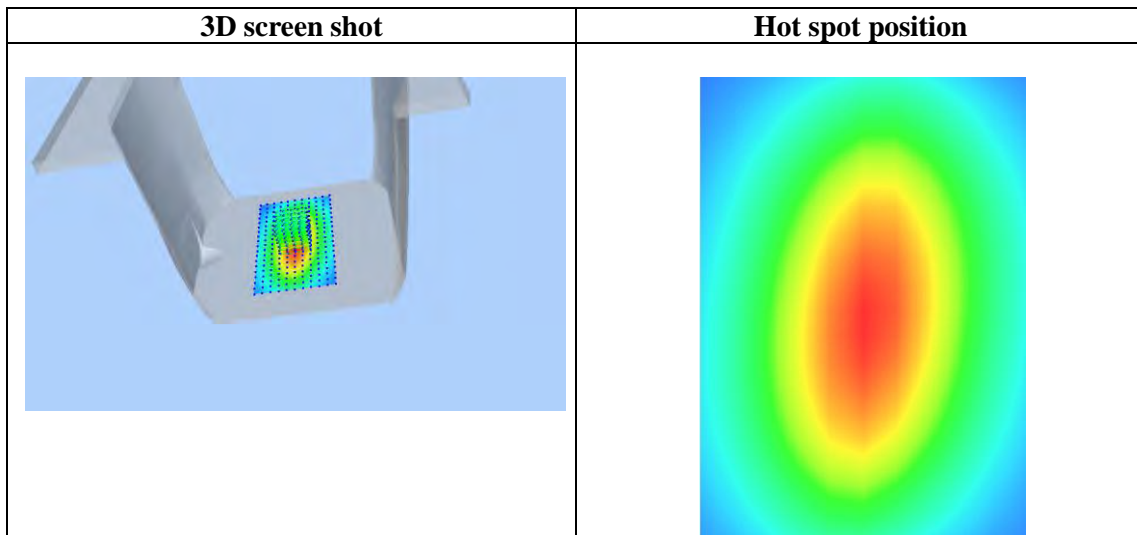
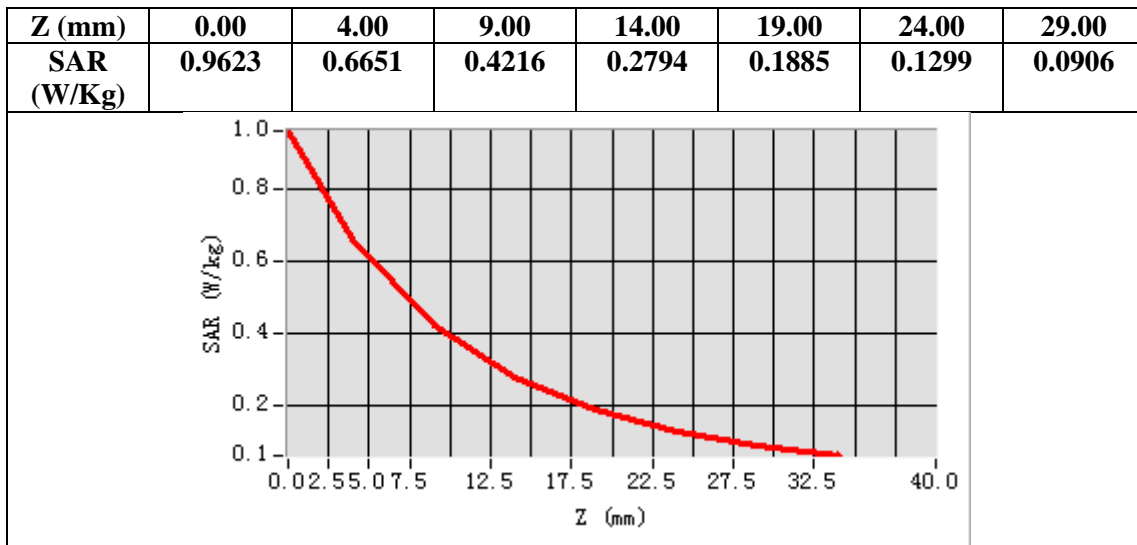

Test Laboratory: AGC Lab
System Check Body 835 MHz
DUT: Dipole 835 MHz Type: SID 835

Date: July 02,2017

Communication System CW; Communication System Band: D835 (835.0 MHz); Duty Cycle: 1:1; Conv.F=5.94
Frequency: 835 MHz; Medium parameters used: $f = 835 \text{ MHz}$; $\zeta = 0.96 \text{ mho/m}$; $\epsilon_r = 55.67$; $\rho = 1000 \text{ kg/m}^3$;
Phantom section: Flat Section; Input Power=18dBm
Ambient temperature ($^{\circ}\text{C}$):21.9, Liquid temperature ($^{\circ}\text{C}$): 21.5

SATIMO Configuration:

- Probe: SSE5; Calibrated: 12/05/2016; Serial No.: SN 14/16 EP308
- Sensor-Surface: 4mm (Mechanical Surface Detection)
- Phantom: SAM twin phantom
- Measurement SW: OpenSAR V4_02_32

Configuration/System Check 835MHz Body/Area Scan: Measurement grid: dx=8mm, dy=8mm

Configuration/System Check 835MHz Body/Zoom Scan: Measurement grid: dx=8mm,dy=8mm, dz=5mm

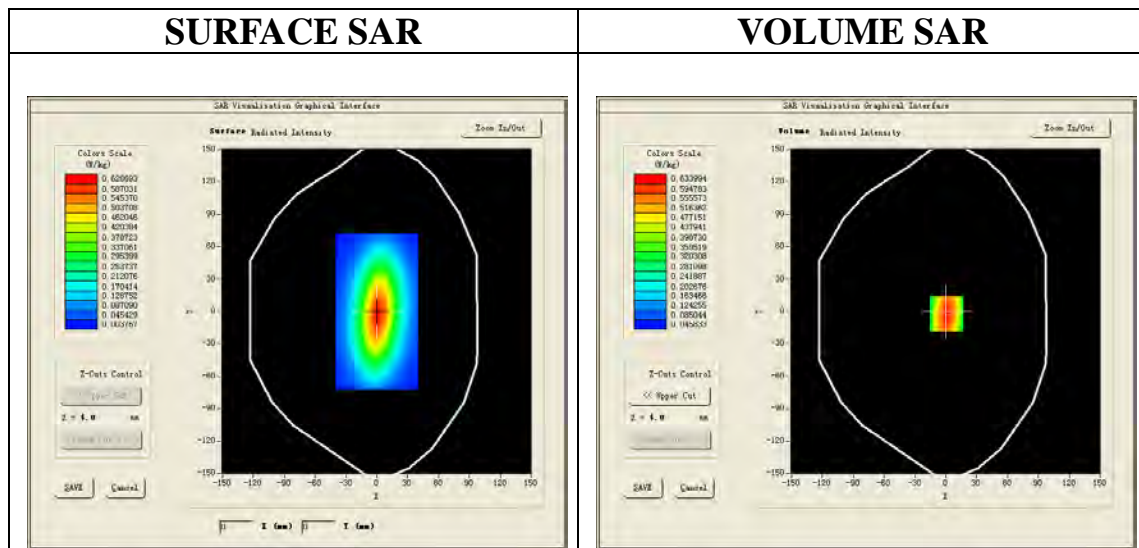

Maximum location: X=1.00, Y=-2.00
SAR Peak: 0.92 W/kg

SAR 10g (W/Kg)	0.374120
SAR 1g (W/Kg)	0.609572

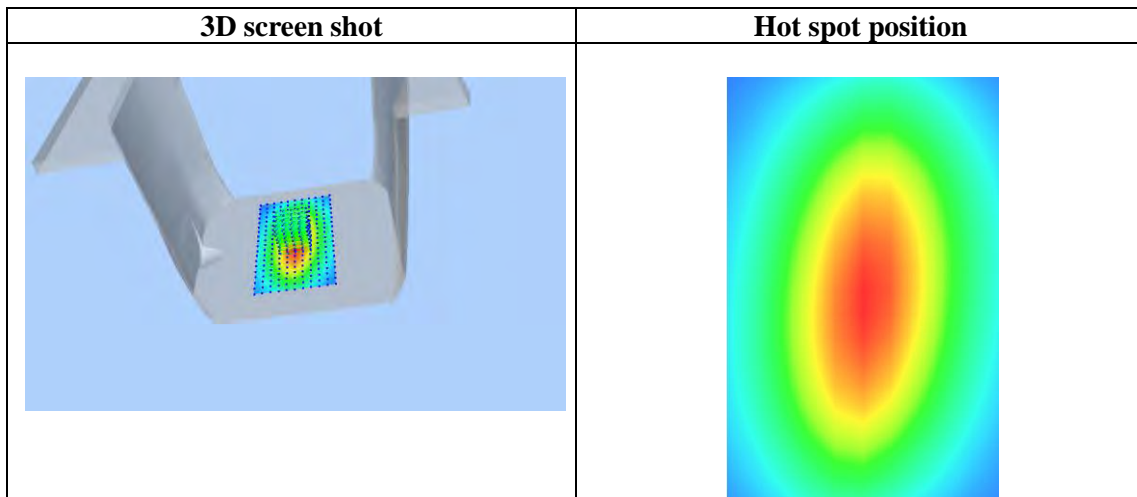
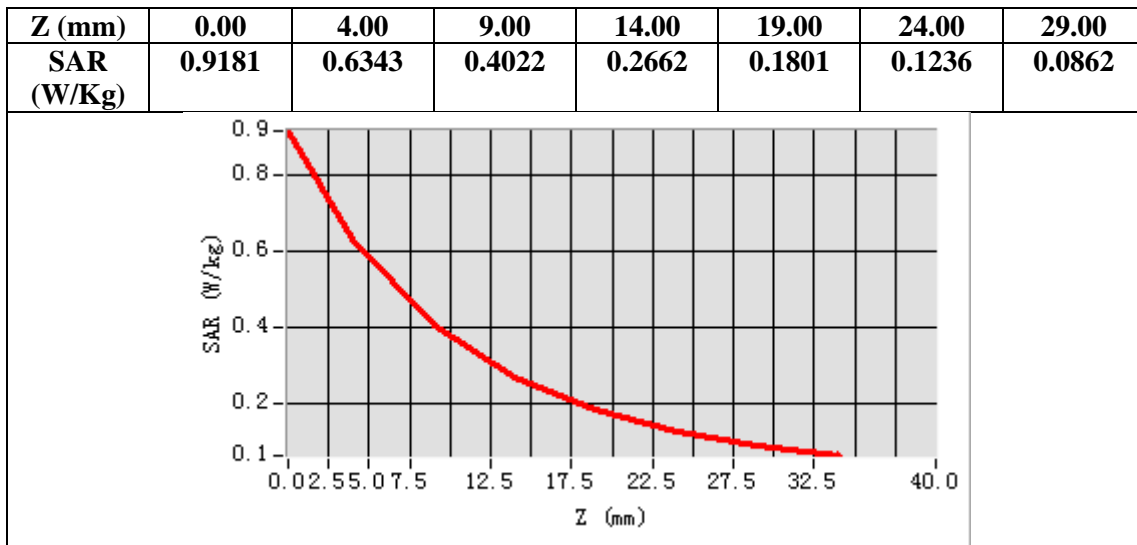

Test Laboratory: AGC Lab
System Check Head 1750MHz

Date: July 02,2017

DUT: Dipole 1800 MHz; Type: SID 1800

Communication System: CW; Communication System Band: D1700 (1750.0 MHz); Duty Cycle:1:1; Conv.F=4.92
Frequency: 1750 MHz; Medium parameters used: $f = 1750\text{MHz}$; $\zeta = 1.38\text{mho/m}$; $\epsilon_r = 40.11$; $\rho = 1000 \text{ kg/m}^3$;
Phantom section: Flat Section; Input Power=18dBm
Ambient temperature ($^{\circ}\text{C}$): 22.1, Liquid temperature ($^{\circ}\text{C}$): 21.3

SATIMO Configuration:

Probe: SSE5; Calibrated: 07/05/2016; Serial No.: SN 14/16 EP307

- Sensor-Surface: 4mm (Mechanical Surface Detection)
- Phantom: SAM twin phantom
- Measurement SW: OpenSAR V4_02_35

Configuration/System Check 1750MHz Head/Area Scan: Measurement grid: dx=8mm,dy=8mm

Configuration/System Check 1750MHz Head/Zoom Scan: Measurement grid: dx=8mm,dy=8mm, dz=5mm

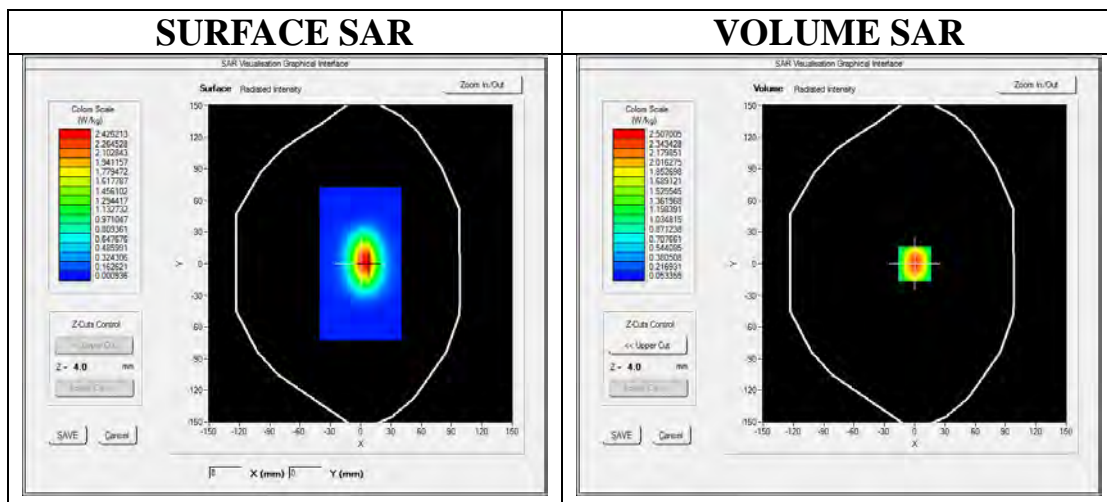

Maximum location: X=0.00, Y=0.00

SAR Peak: 3.95 W/kg

SAR 10g (W/Kg)	1.268513
SAR 1g (W/Kg)	2.370125

Z (mm)	0.00	4.00	9.00	14.00	19.00	24.00	29.00
SAR (W/Kg)	3.9655	2.5074	1.3827	0.7926	0.4607	0.2735	0.1619

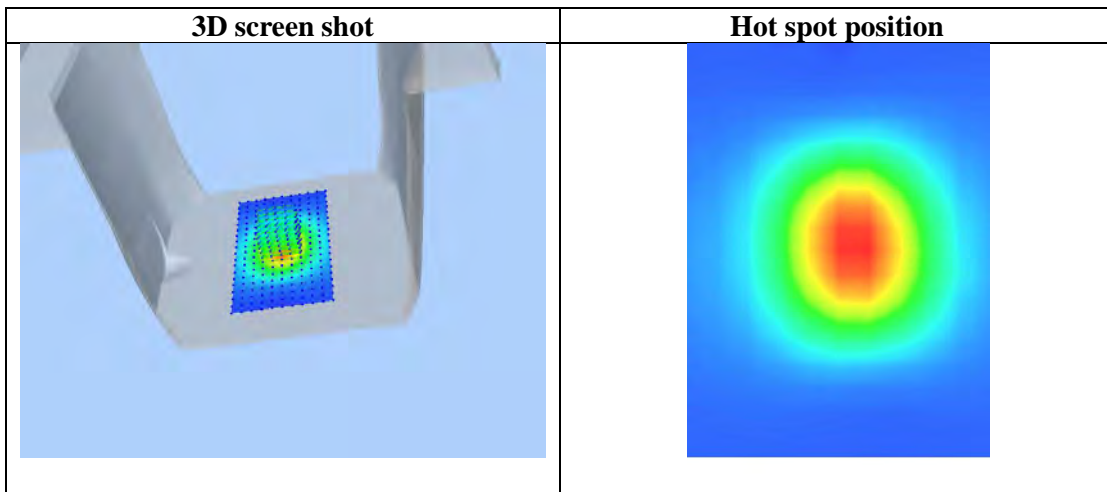
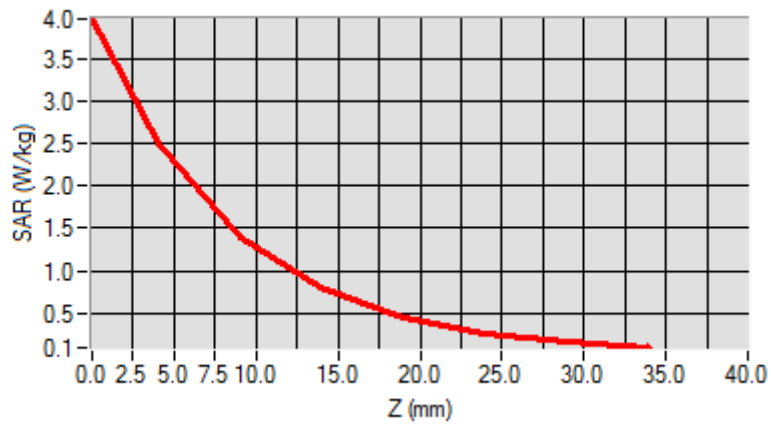

Test Laboratory: AGC Lab
System Check Body 1750MHz
DUT: Dipole 1800 MHz; Type: SID 1800

Date: July 02,2017

Communication System: CW; Communication System Band: D1700 (1750.0 MHz); Duty Cycle:1:1; Conv.F=5.06
Frequency: 1750MHz; Medium parameters used: $f = 1750\text{MHz}$; $\zeta = 1.49 \text{ mho/m}$; $\epsilon_r = 52.66$; $\rho = 1000 \text{ kg/m}^3$;
Phantom section: Flat Section; Input Power=18dBm
Ambient temperature ($^{\circ}\text{C}$): 22.1, Liquid temperature ($^{\circ}\text{C}$): 21.5

SATIMO Configuration:

Probe: SSE5; Calibrated: 07/05/2016; Serial No.: SN 14/16 EP307

- Sensor-Surface: 4mm (Mechanical Surface Detection)
- Phantom: SAM twin phantom
- Measurement SW: OpenSAR V4_02_35

Configuration/System Check 1750MHz Body/Area Scan: Measurement grid: dx=8mm,dy=8mm

Configuration/System Check 1750MHz Body/Zoom Scan: Measurement grid: dx=8mm,dy=8mm, dz=5mm

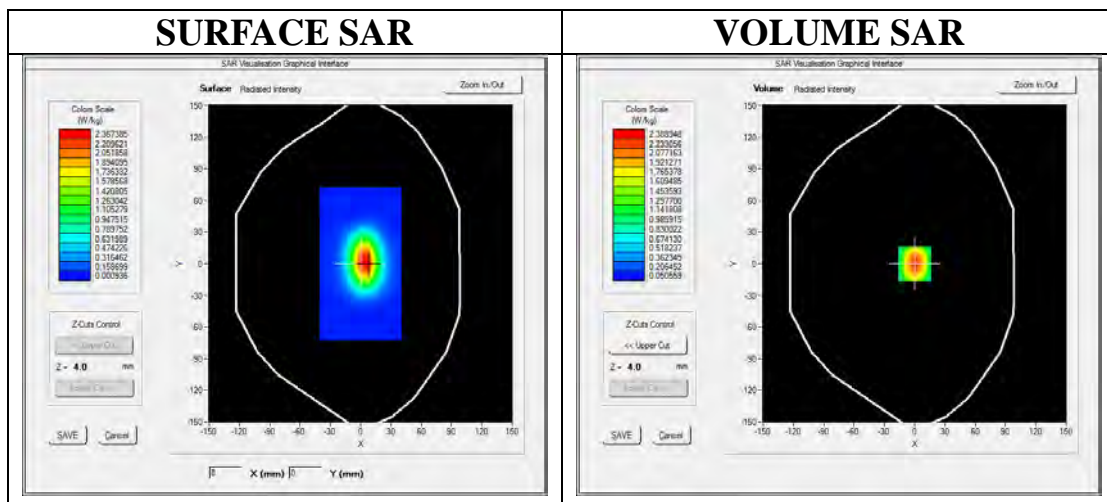

Maximum location: X=0.00, Y=0.00

SAR Peak: 3.78 W/kg

SAR 10g (W/Kg)	1.210254
SAR 1g (W/Kg)	2.261745

Z (mm)	0.00	4.00	9.00	14.00	19.00	24.00	29.00
SAR (W/Kg)	3.7801	2.3893	1.3181	0.7545	0.4392	0.2594	0.1537

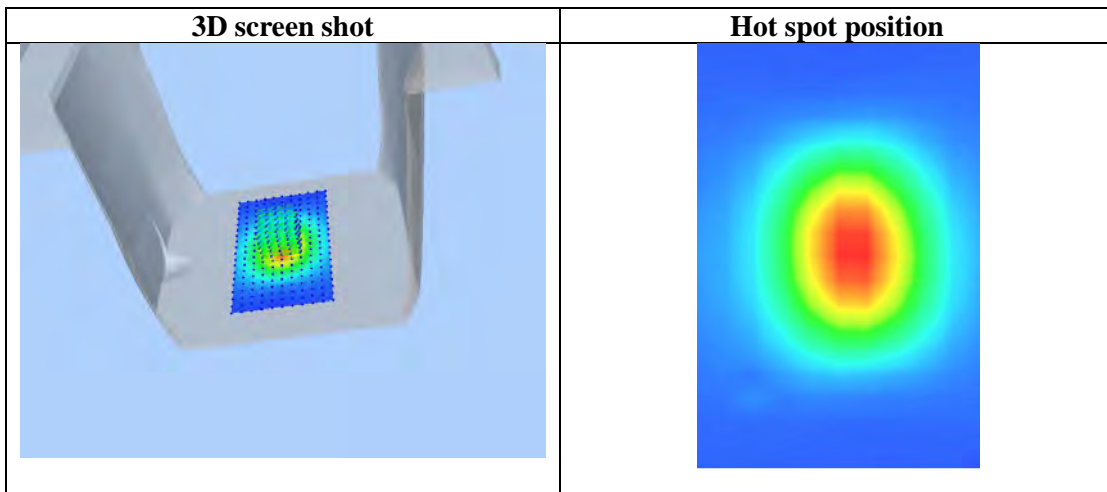
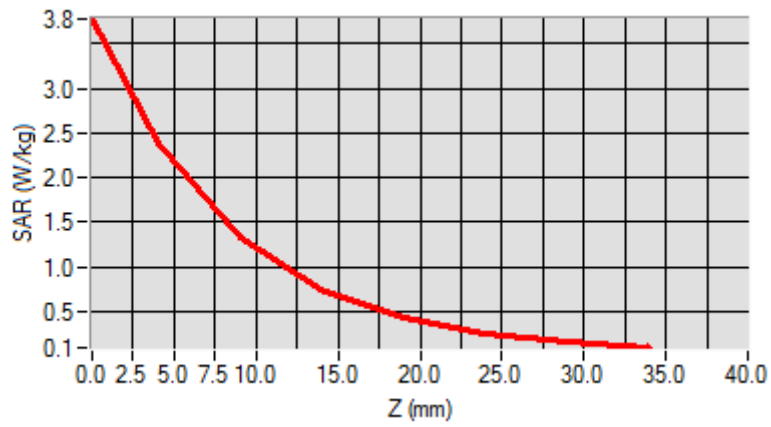

Test Laboratory: AGC Lab
System Check Head 1900MHz

Date: June 28, 2017

DUT: Dipole 1900 MHz; Type: SID 1900

Communication System: CW; Communication System Band: D1900 (1900.0 MHz); Duty Cycle:1:1; Conv.F=5.14
Frequency: 1900 MHz; Medium parameters used: $f = 1900$ MHz; $\zeta = 1.38$ mho/m; $\epsilon_r = 39.51$; $\rho = 1000$ kg/m³ ;
Phantom section: Flat Section; Input Power=18dBm
Ambient temperature (°C):22.1, Liquid temperature (°C): 21.3

SATIMO Configuration:

Probe: SSE5; Calibrated: 07/05/2016; Serial No.: SN 14/16 EP307

- Sensor-Surface: 4mm (Mechanical Surface Detection)
- Phantom: SAM twin phantom
- Measurement SW: OpenSAR V4_02_35

Configuration/System Check 1900MHz Head/Area Scan: Measurement grid: dx=8mm, dy=8mm

Configuration/System Check 1900MHz Head/Zoom Scan: Measurement grid: dx=8mm,dy=8mm, dz=5mm

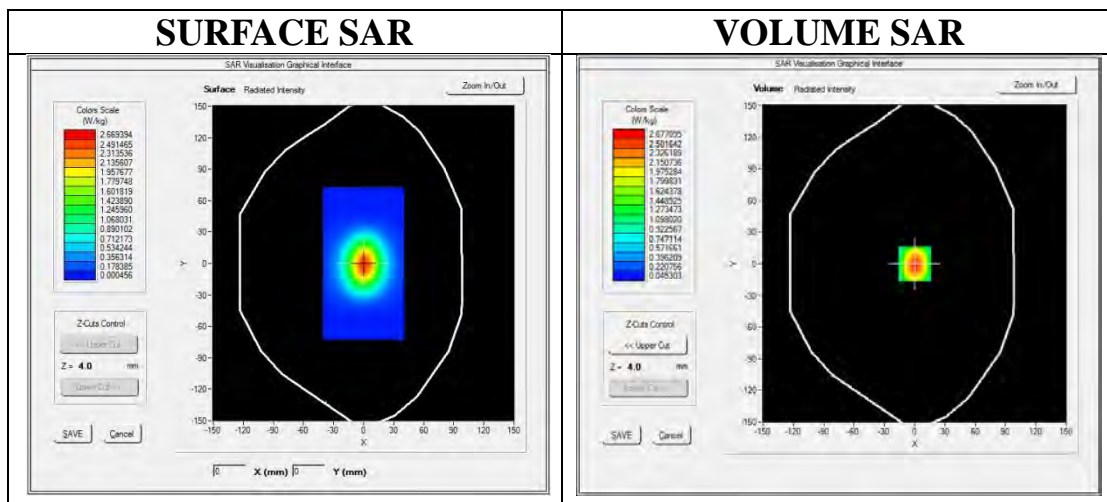

Maximum location: X=0.00, Y=0.00

SAR Peak: 4.24 W/kg

SAR 10g (W/Kg)	1.335305
SAR 1g (W/Kg)	2.540856

Z (mm)	0.00	4.00	9.00	14.00	19.00	24.00	29.00
SAR (W/Kg)	4.2715	2.6771	1.4533	0.8200	0.4657	0.2699	0.1562

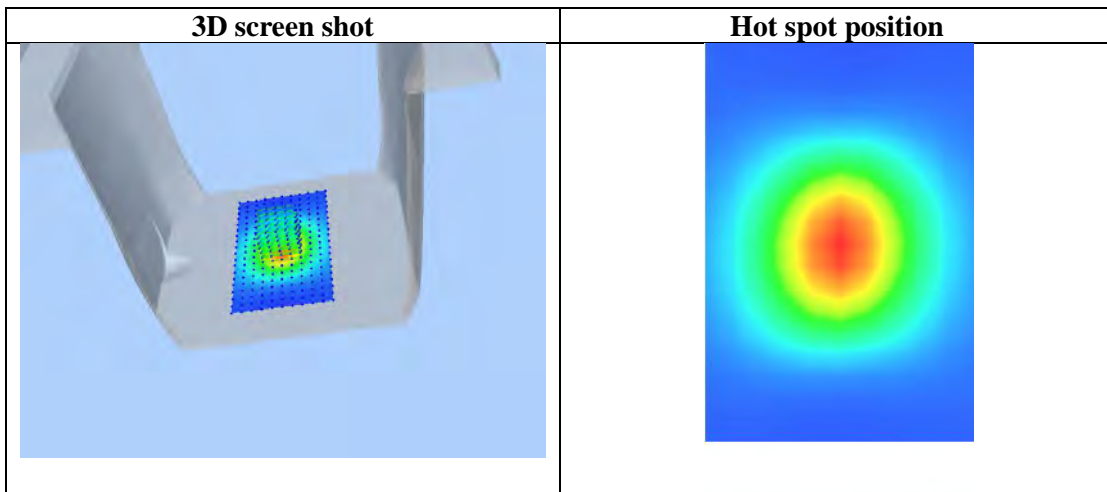
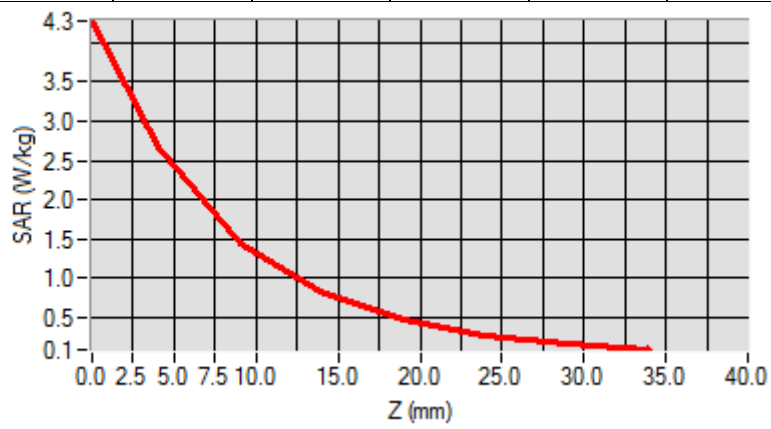

Test Laboratory: AGC Lab
System Check Body 1900MHz
DUT: Dipole 1900 MHz; Type: SID 1900

Date: June 28, 2017

Communication System: CW; Communication System Band: D1900 (1900.0 MHz); Duty Cycle:1:1; Conv.F=5.34
Frequency: 1900 MHz; Medium parameters used: $f = 1900$ MHz; $\zeta = 1.51$ mho/m; $\epsilon_r = 53.58$; $\rho = 1000$ kg/m³ ;
Phantom section: Flat Section; Input Power=18dBm
Ambient temperature (°C):22.1, Liquid temperature (°C): 21.5

SATIMO Configuration:

Probe: SSE5; Calibrated: 07/05/2016; Serial No.: SN 14/16 EP307

- Sensor-Surface: 4mm (Mechanical Surface Detection)
- Phantom: SAM twin phantom
- Measurement SW: OpenSAR V4_02_35

Configuration/System Check 1900MHz Body/Area Scan: Measurement grid: dx=8mm, dy=8mm

Configuration/System Check 1900MHz Body/Zoom Scan: Measurement grid: dx=8mm,dy=8mm, dz=5mm

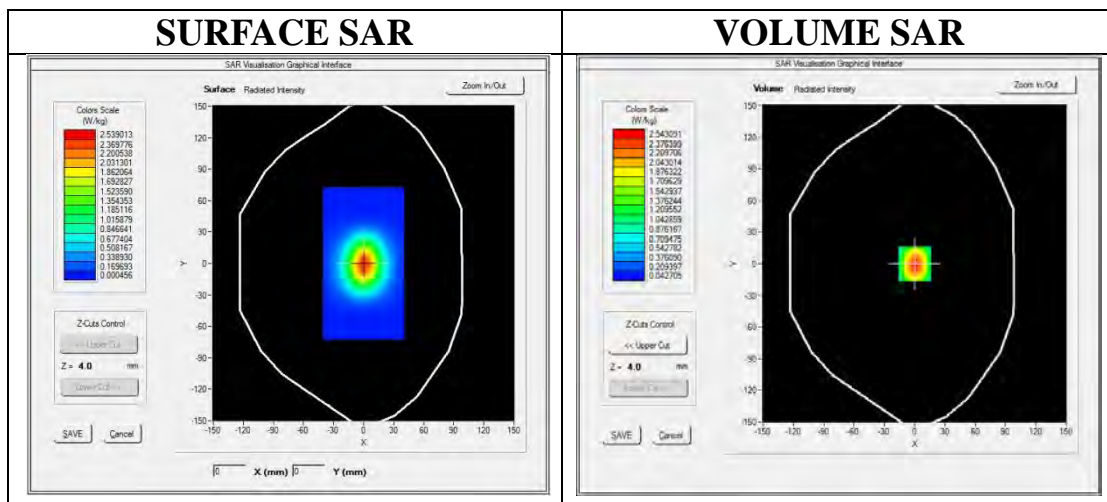

Maximum location: X=0.00, Y=0.00

SAR Peak: 4.05 W/kg

SAR 10g (W/Kg)	1.269532
SAR 1g (W/Kg)	2.416594

Z (mm)	0.00	4.00	9.00	14.00	19.00	24.00	29.00
SAR (W/Kg)	4.0561	2.5438	1.3829	0.7777	0.4434	0.2569	0.1489

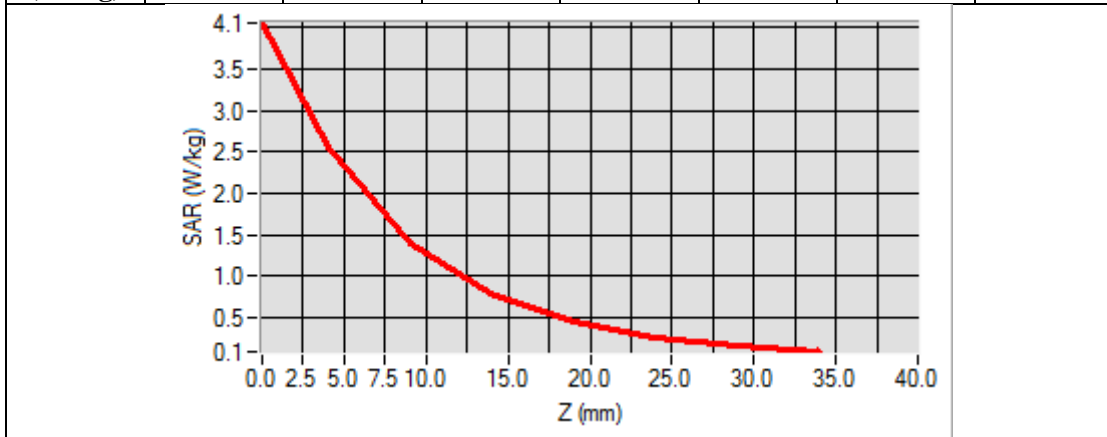

3D screen shot	Hot spot position
<p>A 3D perspective view of a grey, L-shaped device. A small rectangular area on the inner surface of the 'L' is highlighted with a color-coded heatmap, showing a central red/orange area (highest SAR) transitioning to yellow, green, and blue (lower SAR) towards the edges.</p>	<p>A 2D top-down view of the hot spot. It shows a central red/orange circular region, surrounded by concentric rings of yellow, green, and blue, indicating the spatial distribution of SAR intensity.</p>

Test Laboratory: AGC Lab
System Check Head 2450 MHz

Date: July 12,2017

DUT: Dipole 2450 MHz Type: SID 2450

Communication System CW; Communication System Band: D2450 (2450.0 MHz); Duty Cycle: 1:1; Conv.F=5.19
Frequency: 2450 MHz; Medium parameters used: $f = 2450$ MHz; $\zeta = 1.84$ mho/m; $\epsilon_r = 38.59$; $\rho = 1000$ kg/m³ ;
Phantom section: Flat Section; Input Power=18dBm
Ambient temperature (°C):22.1, Liquid temperature (°C): 21.6

SATIMO Configuration

- Probe: SSE5; Calibrated: 12/05/2016; Serial No.: SN 14/16 EP308
- Sensor-Surface: 4mm (Mechanical Surface Detection)
- Phantom: SAM twin phantom
- Measurement SW: OpenSAR V4_02_32

Configuration/System Check 2450MHz Head/Area Scan: Measurement grid: dx=8mm, dy=8mm

Configuration/System Check 2450MHz Head/Zoom Scan: Measurement grid: dx=5mm,dy=5mm, dz=5mm

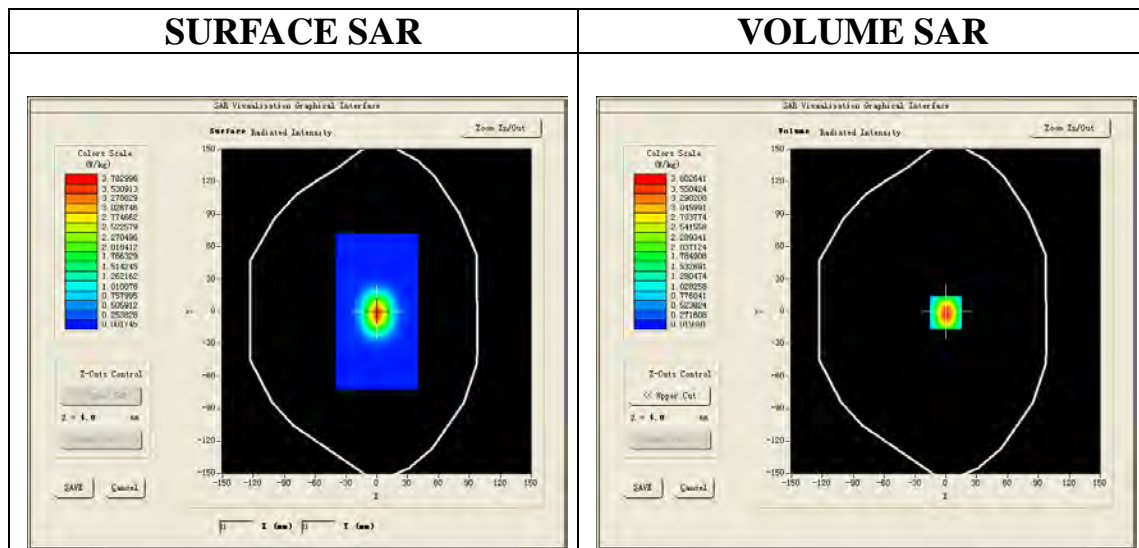

Maximum location: X=0.00, Y=-1.00
SAR Peak: 6.50 W/kg

SAR 10g (W/Kg)	1.566009
SAR 1g (W/Kg)	3.473732

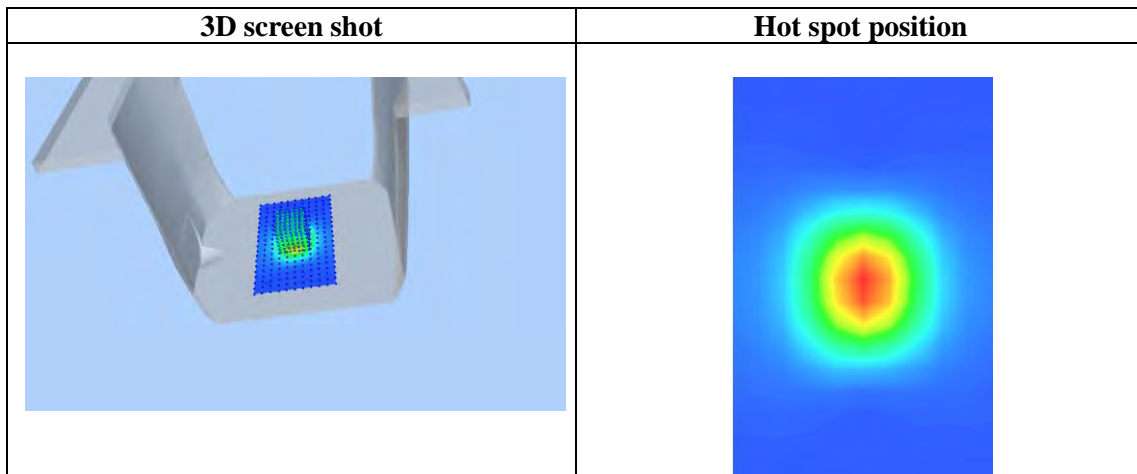
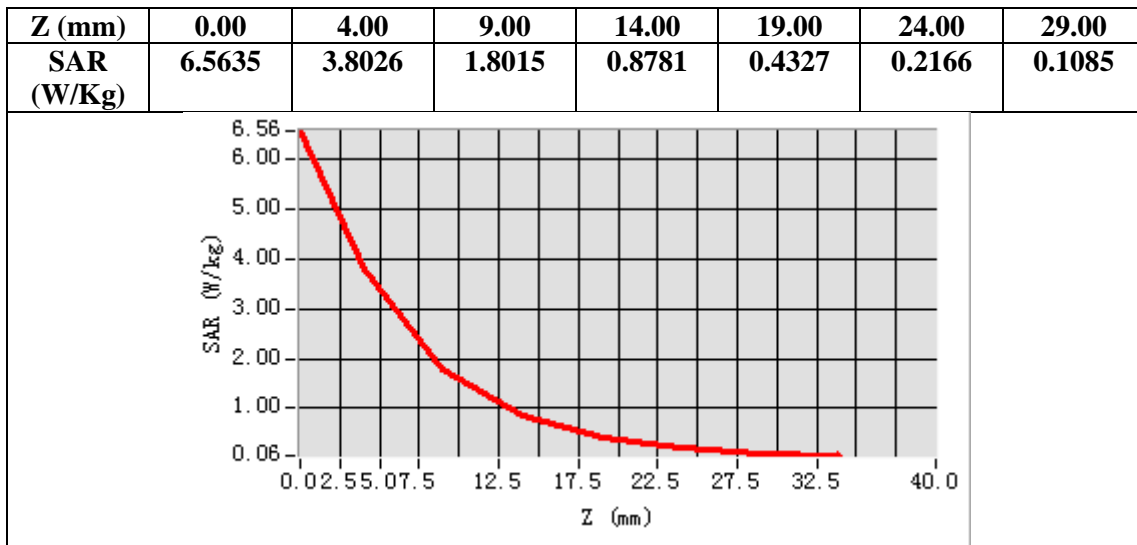

Test Laboratory: AGC Lab
System Check Body 2450 MHz

Date: July 12,2017

DUT: Dipole 2450 MHz Type: SID 2450

Communication System CW; Communication System Band: D2450 (2450.0 MHz); Duty Cycle: 1:1; Conv.F=5.33
Frequency: 2450 MHz; Medium parameters used: $f = 2450$ MHz; $\zeta = 1.93$ mho/m; $\epsilon_r = 53.12$; $\rho = 1000$ kg/m³ ;
Phantom section: Flat Section; Input Power=18dBm
Ambient temperature (°C):22.1, Liquid temperature (°C): 21.7

SATIMO Configuration

- Probe: SSE5; Calibrated: 12/05/2016; Serial No.: SN 14/16 EP308
- Sensor-Surface: 4mm (Mechanical Surface Detection)
- Phantom: SAM twin phantom
- Measurement SW: OpenSAR V4_02_32

Configuration/System Check 2450MHz Body/Area Scan: Measurement grid: dx=8mm, dy=8mm

Configuration/System Check 2450MHz Body/Zoom Scan: Measurement grid: dx=5mm,dy=5mm, dz=5mm

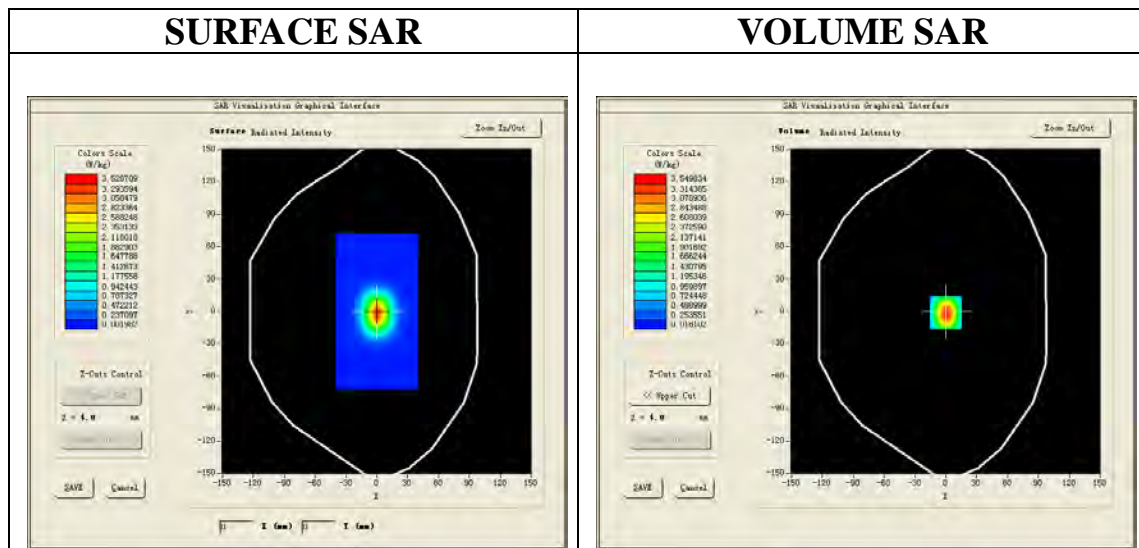

Maximum location: X=0.00, Y=-1.00
SAR Peak: 6.09 W/kg

SAR 10g (W/Kg)	1.460182
SAR 1g (W/Kg)	3.243430

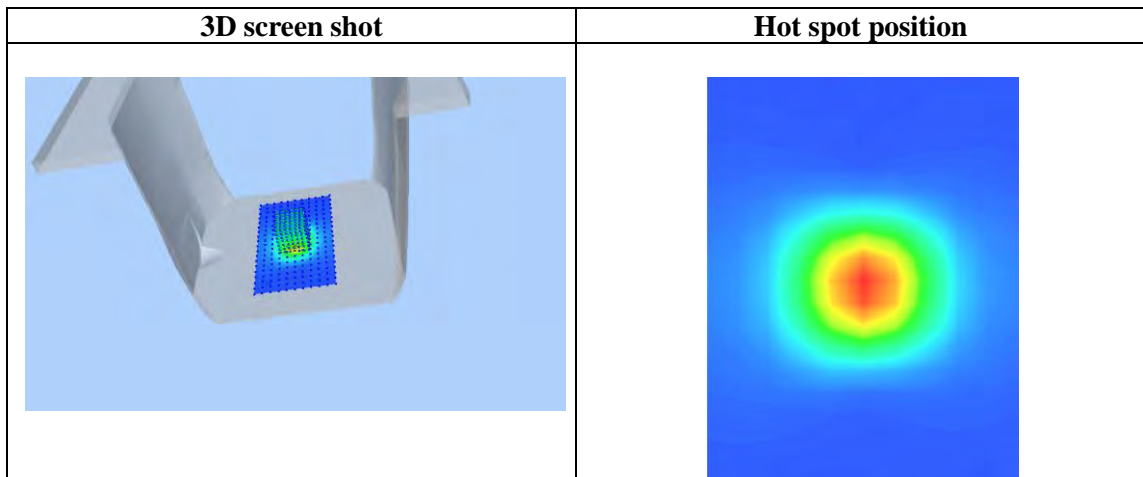
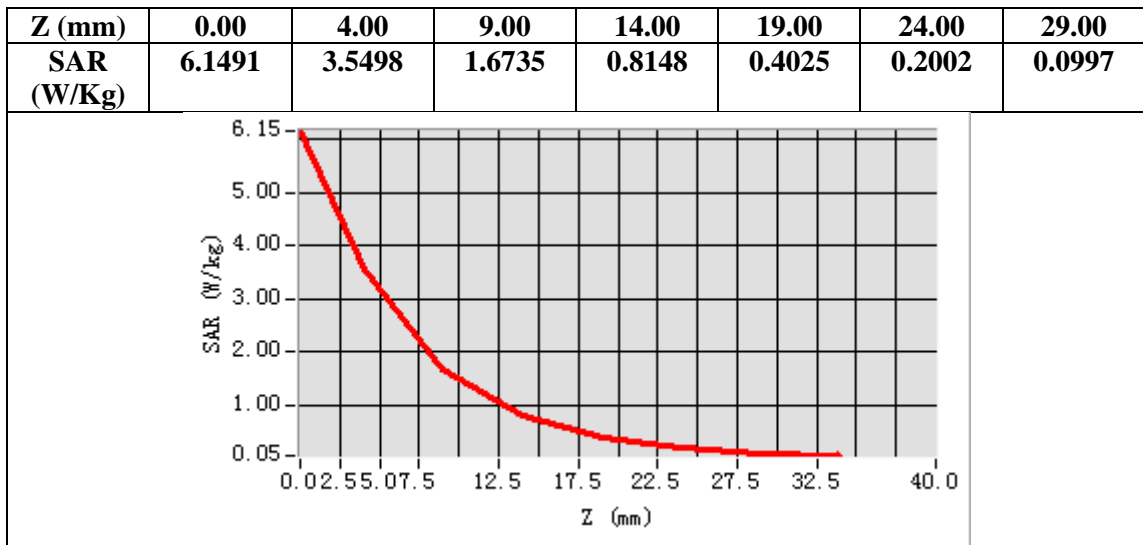

Test Laboratory: AGC Lab
System Check Head 2600MHz

Date: July 03,2017

DUT: Dipole 2600 MHz; Type: SID 2600

Communication System: CW; Communication System Band: D2600 (2600.0 MHz); Duty Cycle: 1:1; Conv.F=5.07
Frequency:2600 MHz; Medium parameters used: $f = 2600$ MHz; $\zeta = 1.92$ mho/m; $\epsilon_r = 37.68$; $\rho = 1000$ kg/m³ ;
Phantom section: Flat Section; Input Power=18dBm
Ambient temperature (°C): 21.7, Liquid temperature (°C): 21.1

SATIMO Configuration:

- Probe: SSE5; Calibrated: 12/05/2016; Serial No.: SN 14/16 EP308
- Sensor-Surface: 4mm (Mechanical Surface Detection)
- Phantom: SAM twin phantom
- Measurement SW: OpenSAR V4_02_32

Configuration/System Check 2600 Head/Area Scan: Measurement grid: dx=8mm,dy=8mm

Configuration/System Check 2600 Head/Zoom Scan: Measurement grid: dx=8mm,dy=8mm, dz=5mm

Area Scan	sam_direct_droit2_surf8mm.txt
ZoomScan	5x5x7,dx=8mm dy=8mm dz=5mm
Phantom	SAM twin phantom
Device Position	Flat
Band	CW 2600
Channels	Middle
Signal	Crest factor: 1.0

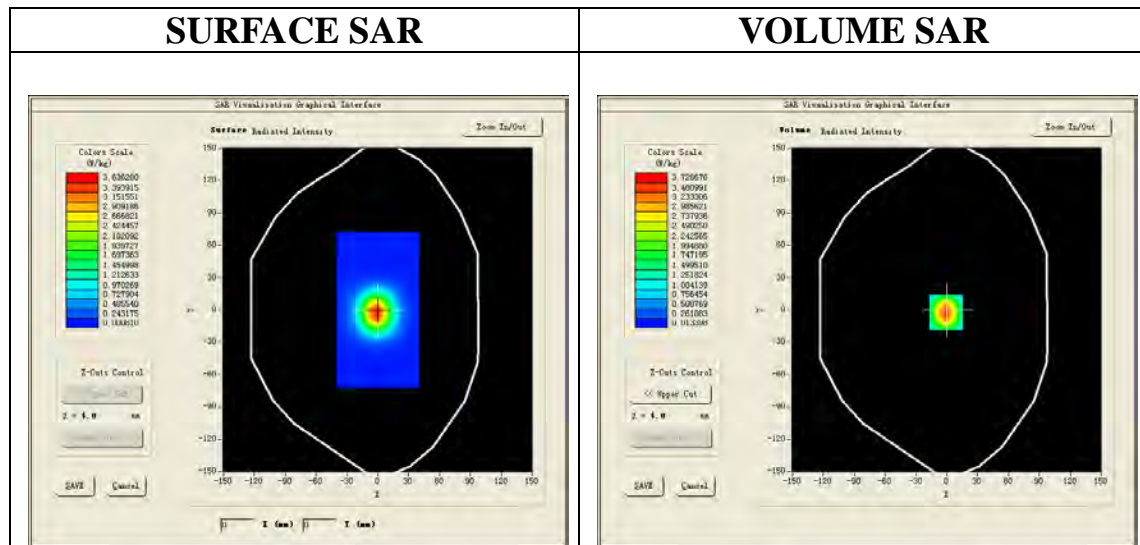

Maximum location: X=-1.00, Y=-2.00

SAR Peak: 6.53 W/kg

SAR 10g (W/Kg)	1.575963
SAR 1g (W/Kg)	3.508412

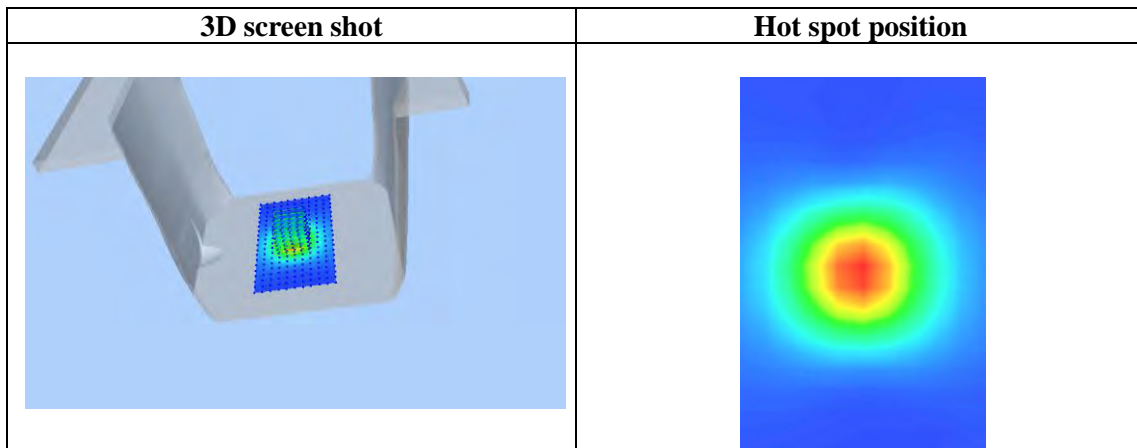
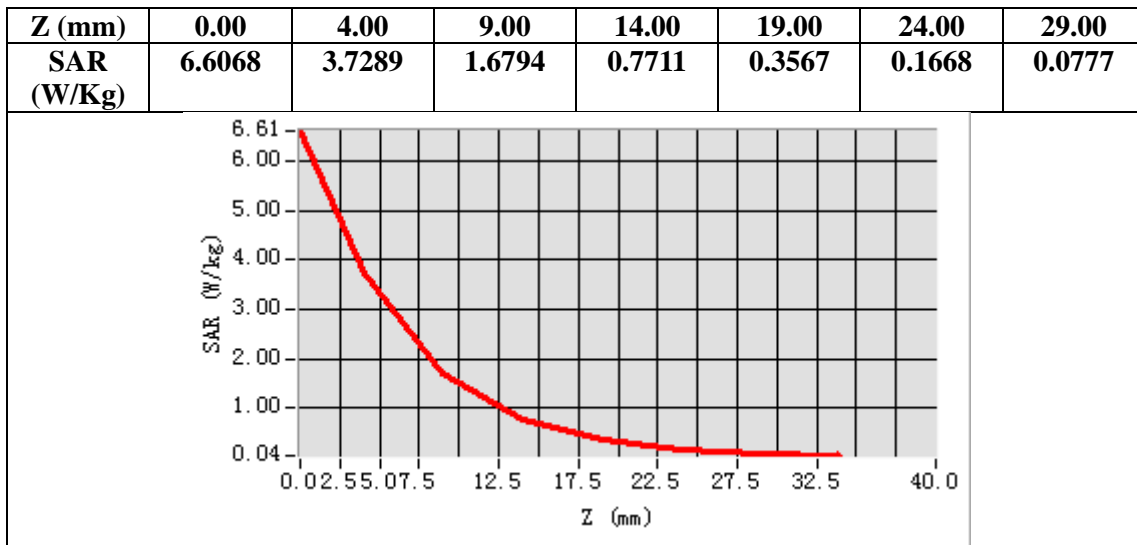

Test Laboratory: AGC Lab
System Check Body 2600MHz

Date: July 03,2017

DUT: Dipole 2600 MHz; Type: SID 2600

Communication System: CW; Communication System Band: D2600 (2600.0 MHz); Duty Cycle: 1:1; Conv.F=5.19
Frequency:2600 MHz; Medium parameters used: $f = 2600$ MHz; $\zeta = 2.16$ mho/m; $\epsilon_r = 52.00$; $\rho = 1000$ kg/m³ ;
Phantom section: Flat Section; Input Power=18dBm
Ambient temperature (°C): 21.7, Liquid temperature (°C): 21.3

SATIMO Configuration:

- Probe: SSE5; Calibrated: 12/05/2016; Serial No.: SN 14/16 EP308
- Sensor-Surface: 4mm (Mechanical Surface Detection)
- Phantom: SAM twin phantom
- Measurement SW: OpenSAR V4_02_32

Configuration/System Check 2600 Body/Area Scan: Measurement grid: dx=8mm,dy=8mm

Configuration/System Check 2600 Body /Zoom Scan: Measurement grid: dx=8mm,dy=8mm, dz=5mm

Area Scan	sam_direct_droit2_surf8mm.txt
ZoomScan	5x5x7,dx=8mm dy=8mm dz=5mm
Phantom	SAM twin phantom
Device Position	Flat
Band	CW 2600
Channels	Middle
Signal	Crest factor: 1.0

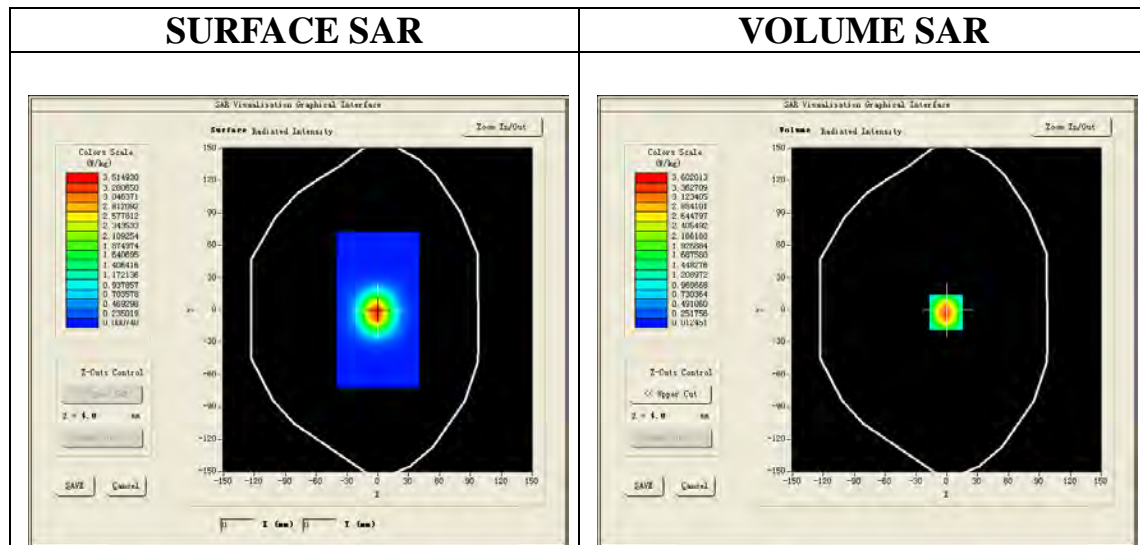

Maximum location: X=-1.00, Y=-2.00

SAR Peak: 6.32 W/kg

SAR 10g (W/Kg)	1.520153
SAR 1g (W/Kg)	3.389567

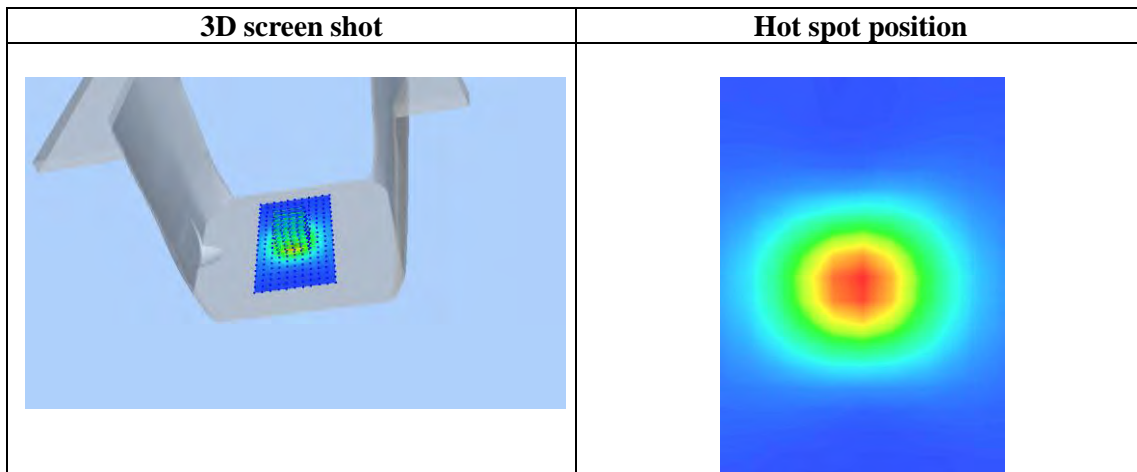
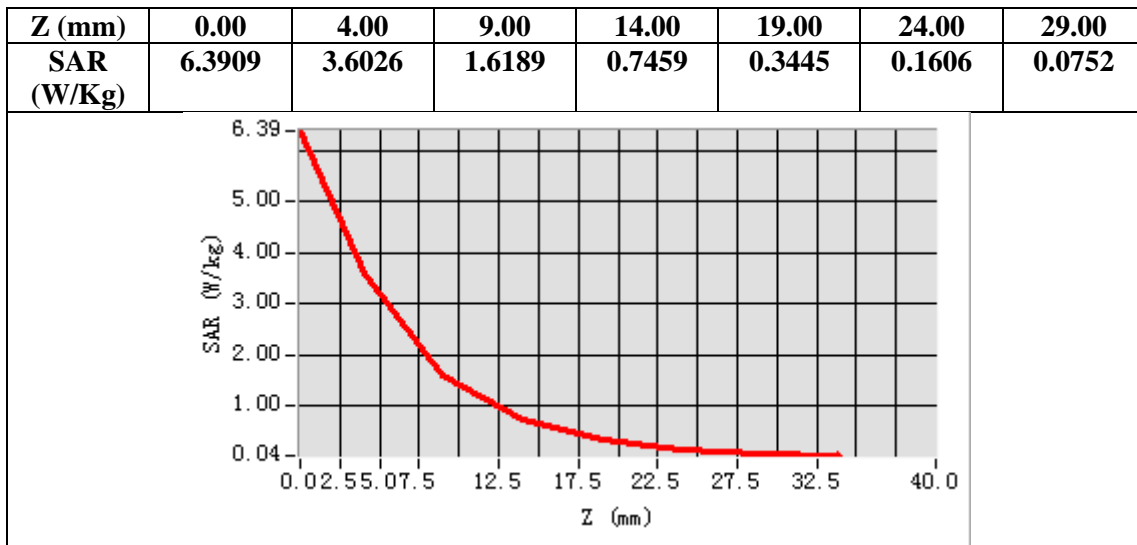

APPENDIX B. SAR MEASUREMENT DATA

Test Laboratory: AGC Lab
GSM 850 Mid-Touch-Right <SIM 1>
DUT: Rugged Mobile Phone; Type: CS24SA

Date: July 02,2017

Communication System: Generic GSM; Communication System Band: GSM 850; Duty Cycle: 1:8.3; Conv.F=5.72;
Frequency: 836.6 MHz; Medium parameters used: $f = 835$ MHz; $\zeta = 0.91$ mho/m; $\epsilon_r = 41.23$; $\rho = 1000$ kg/m³ ;
Phantom section: Right Section
Ambient temperature (°C): 21.9, Liquid temperature (°C): 21.3

SATIMO Configuration:

- Probe: SSE5; Calibrated: 12/05/2016; Serial No.: SN 14/16 EP308
- Sensor-Surface: 4mm (Mechanical Surface Detection)
- Phantom: SAM twin phantom
- Measurement SW: OpenSAR V4_02_32

Configuration/GSM 850 Mid-Touch-Right/Area Scan: Measurement grid: dx=8mm, dy=8mm
Configuration/GSM 850 Mid-Touch-Right/Zoom Scan: Measurement grid: dx=8mm,dy=8mm, dz=5mm;

Area Scan	sam_direct_droit2_surf8mm.txt
ZoomScan	5x5x7,dx=8mm dy=8mm dz=5mm,Complete
Phantom	Right head
Device Position	Cheek
Band	GSM 850
Channels	Middle
Signal	TDMA (Crest factor: 8.0)

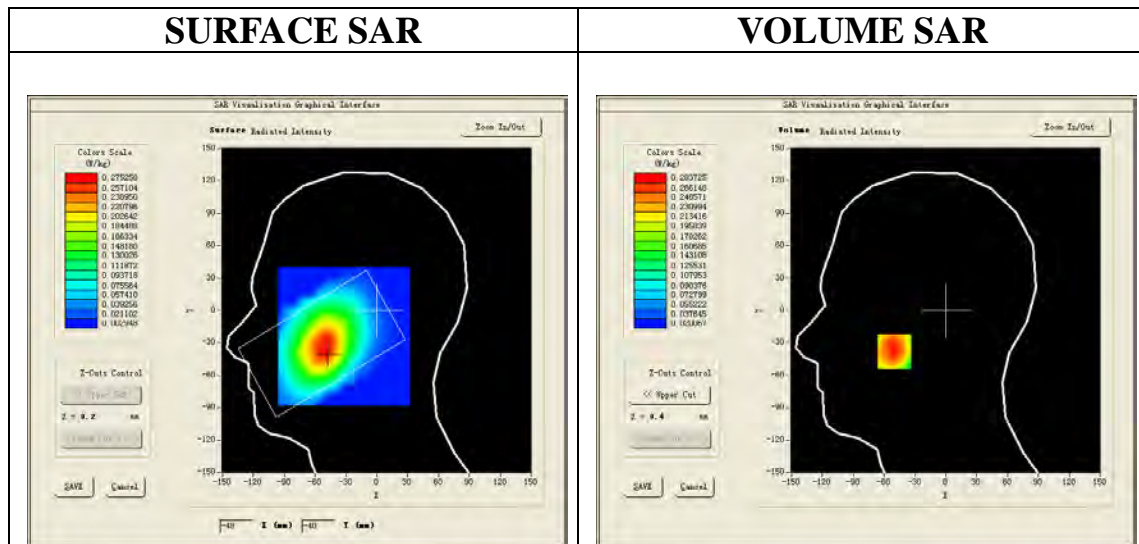

Maximum location: X=-50.00, Y=-38.00
SAR Peak: 0.40 W/kg

SAR 10g (W/Kg)	0.191908
SAR 1g (W/Kg)	0.277019

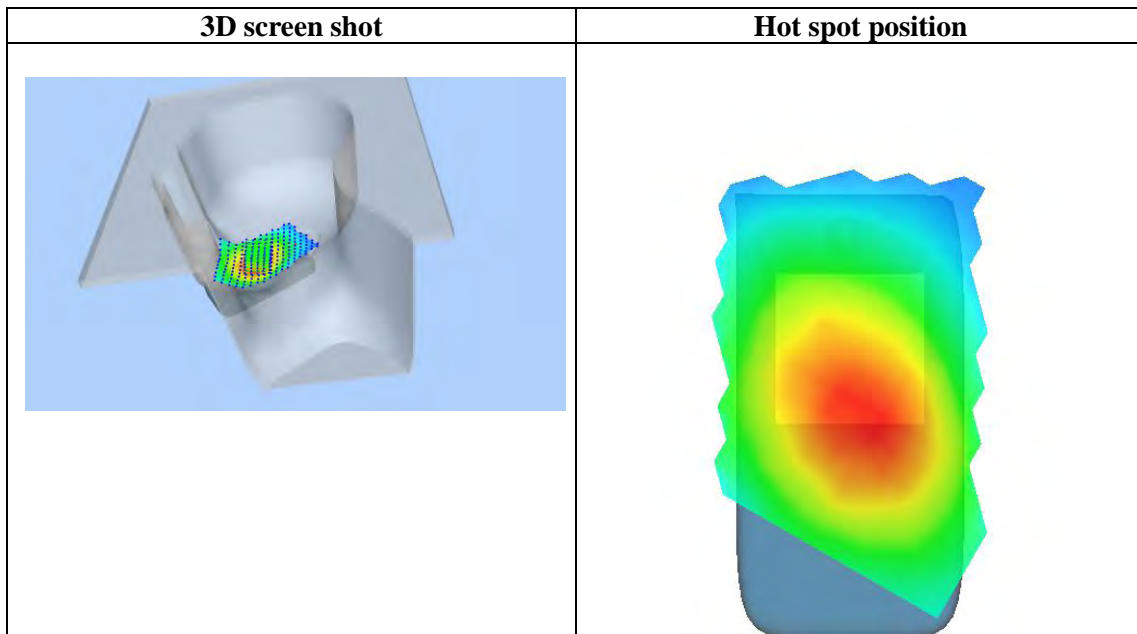
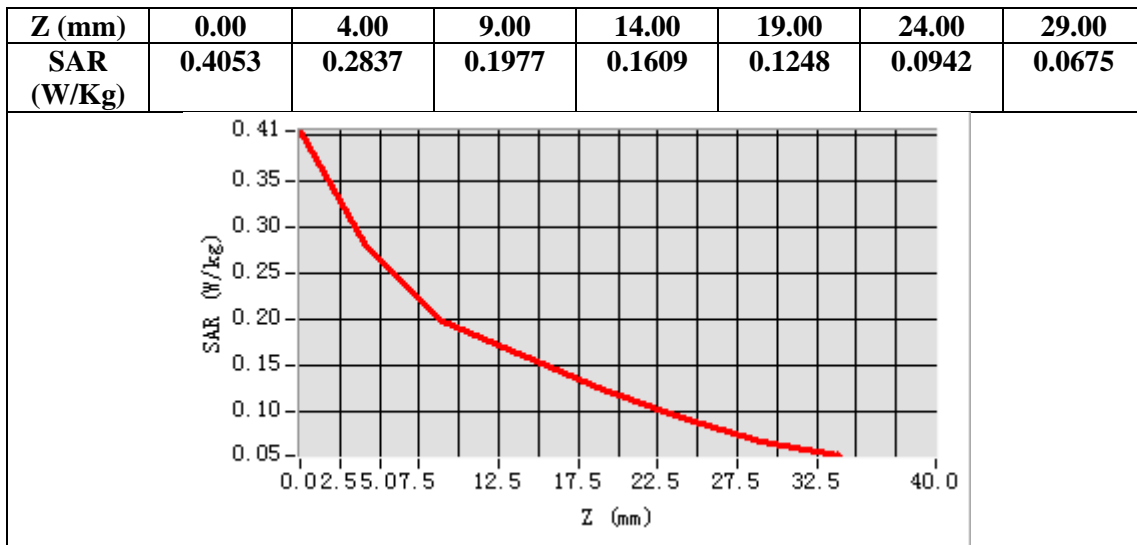

Test Laboratory: AGC Lab
GSM 850 Mid- Body- Back (MS)<SIM 1>
DUT: Rugged Mobile Phone; Type: CS24SA

Date: July 02,2017

Communication System: Generic GSM; Communication System Band: GSM 850; Duty Cycle: 1:8.3; Conv.F=5.94;
Frequency: 836.6 MHz; Medium parameters used: $f = 835$ MHz; $\zeta = 0.97$ mho/m; $\epsilon_r = 55.21$; $\rho = 1000$ kg/m³ ;
Phantom section: Flat Section
Ambient temperature (°C): 21.9, Liquid temperature (°C): 21.5

SATIMO Configuration:

- Probe: SSE5; Calibrated: 12/05/2016; Serial No.: SN 14/16 EP308
- Sensor-Surface: 4mm (Mechanical Surface Detection)
- Phantom: SAM twin phantom
- Measurement SW: OpenSAR V4_02_32

Configuration/GSM 850 Mid-Body-Back/Area Scan: Measurement grid: dx=8mm, dy=8mm
Configuration/GSM 850 Mid-Body-Back/Zoom Scan: Measurement grid: dx=8mm,dy=8mm, dz=5mm;

Area Scan	sam_direct_droit2_surf8mm.txt
ZoomScan	5x5x7,dx=8mm dy=8mm dz=5mm,Complete
Phantom	Validation plane
Device Position	Body Back
Band	GSM 850
Channels	Middle
Signal	TDMA (Crest factor: 8.0)

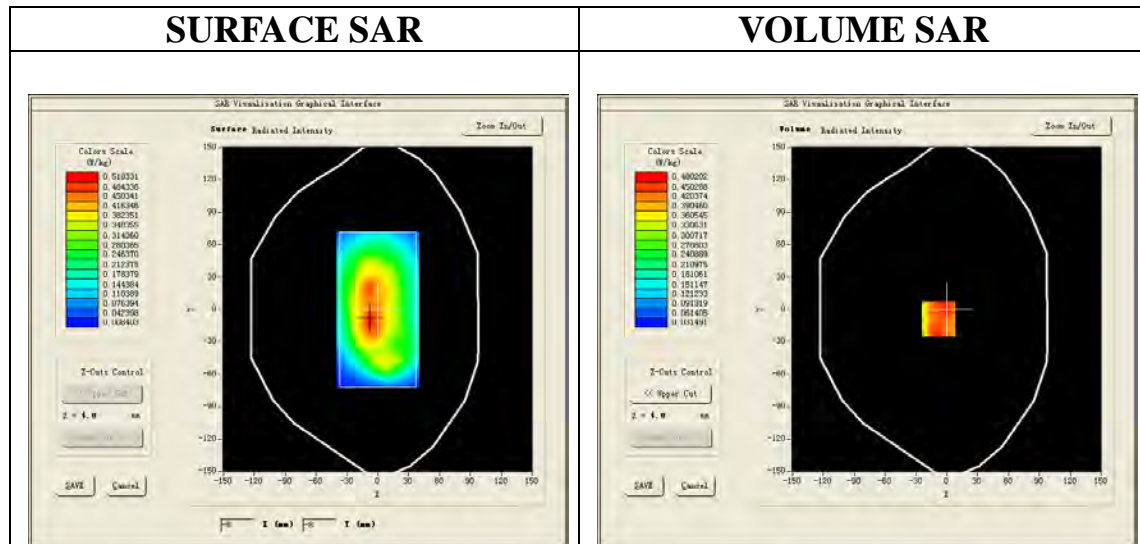

Maximum location: X=-8.00, Y=-9.00

SAR Peak: 0.71 W/kg

SAR 10g (W/Kg)	0.321790
SAR 1g (W/Kg)	0.458736

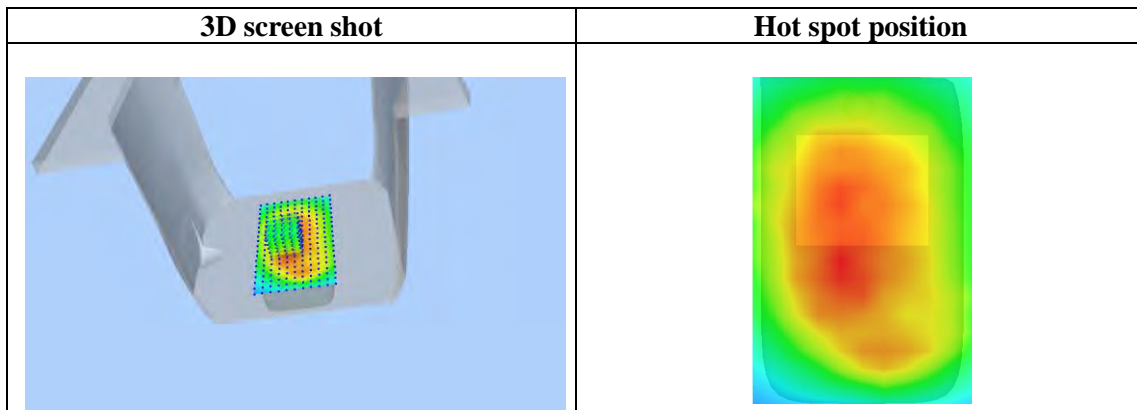
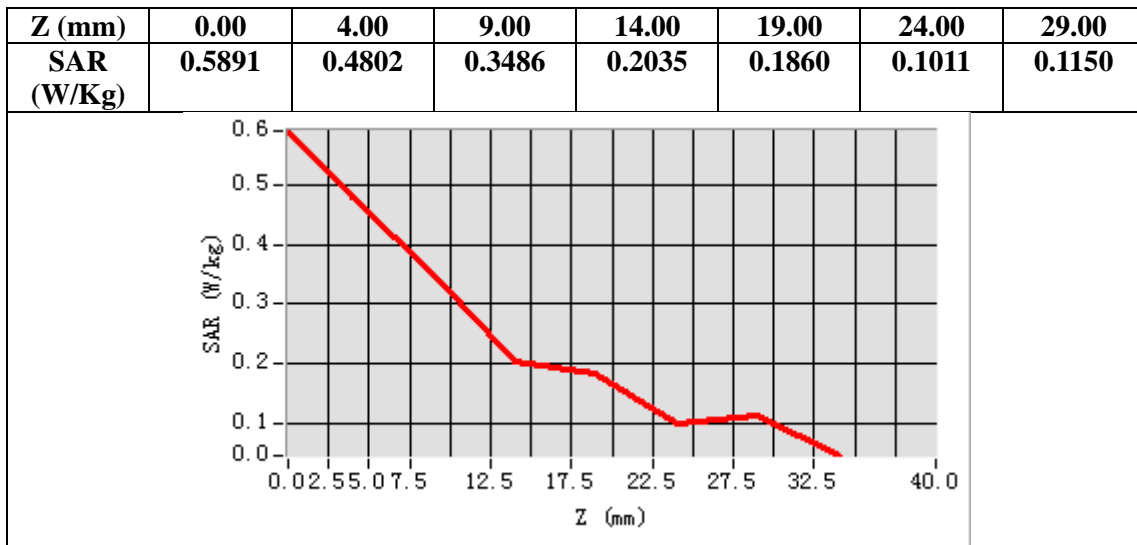

Test Laboratory: AGC Lab
GPRS 850 Mid-Touch-Right (2up) <SIM 1>
DUT: Rugged Mobile Phone; Type: CS24SA

Date: July 02,2017

Communication System: GPRS-2 Slot; Communication System Band: GSM 850; Duty Cycle: 1:4.2; Conv.F=5.72
Frequency: 836.6 MHz; Medium parameters used: $f = 835$ MHz; $\zeta = 0.91$ mho/m; $\epsilon_r = 41.23$; $\rho = 1000$ kg/m³;
Phantom section: Right Section
Ambient temperature (°C): 21.9, Liquid temperature (°C): 21.3

SATIMO Configuration:

- Probe: SSE5; Calibrated: 12/05/2016; Serial No.: SN 14/16 EP308
- Sensor-Surface: 4mm (Mechanical Surface Detection)
- Phantom: SAM twin phantom
- Measurement SW: OpenSAR V4_02_32

Configuration/GPRS 850 Mid-Touch-Right/Area Scan: Measurement grid: dx=8mm, dy=8mm
Configuration/GPRS 850 Mid-Touch-Right/Zoom Scan: Measurement grid: dx=8mm,dy=8mm, dz=5mm

Area Scan	sam_direct_droit2_surf8mm.txt
Zoom Scan	5x5x7,dx=8mm dy=8mm dz=5mm,Complete
Phantom	Right head
Device Position	Cheek
Band	GSM 850
Channels	Middle
Signal	TDMA (Crest factor: 4.0)

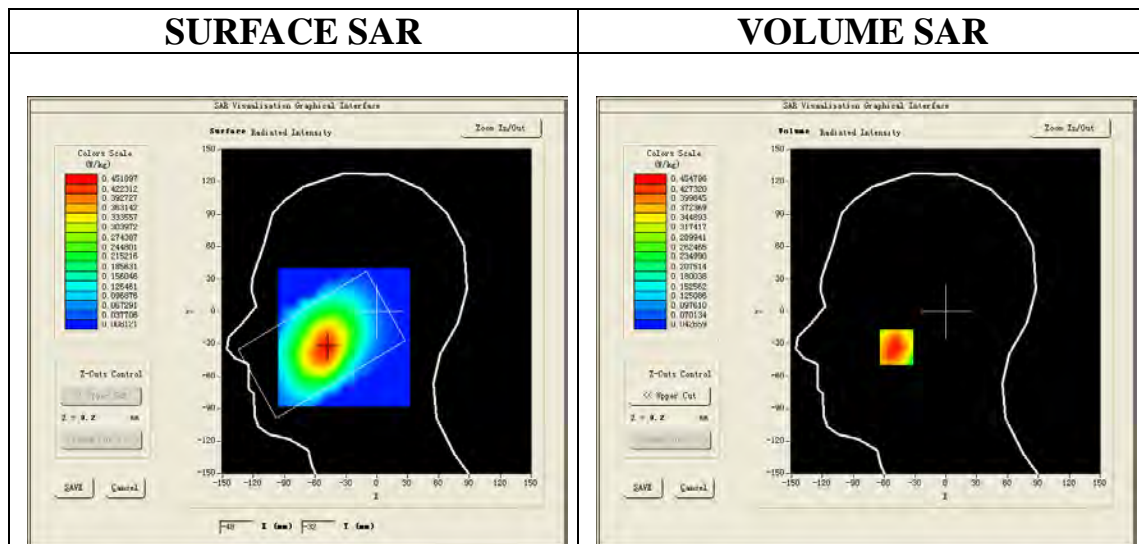

Maximum location: X=-48.00, Y=-33.00

SAR Peak: 0.59 W/kg

SAR 10g (W/Kg)	0.317309
SAR 1g (W/Kg)	0.449342

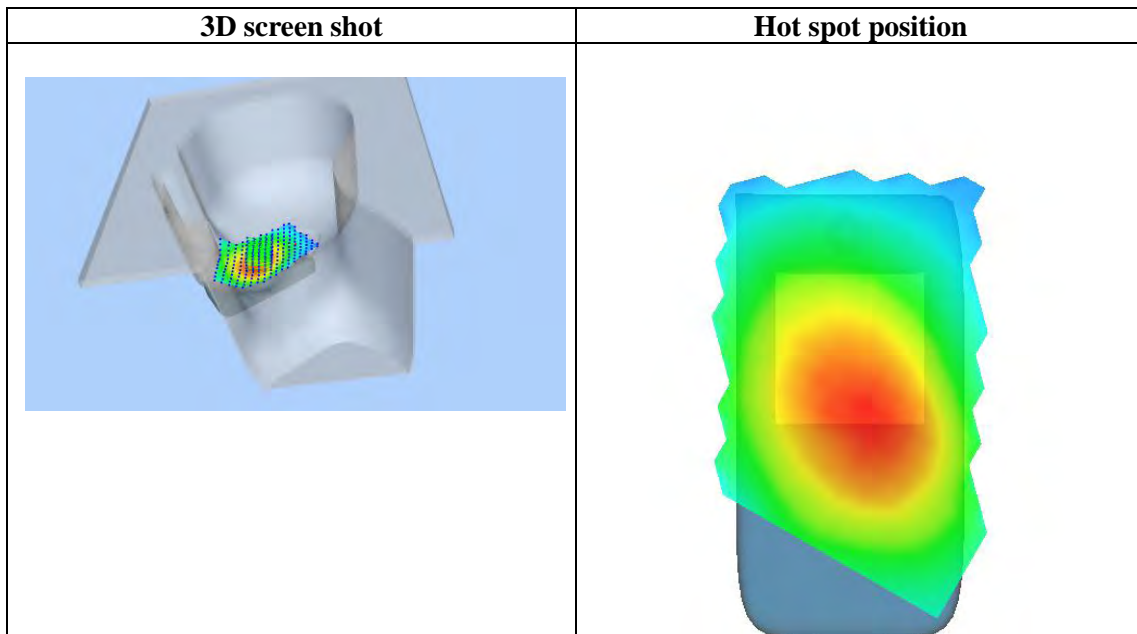
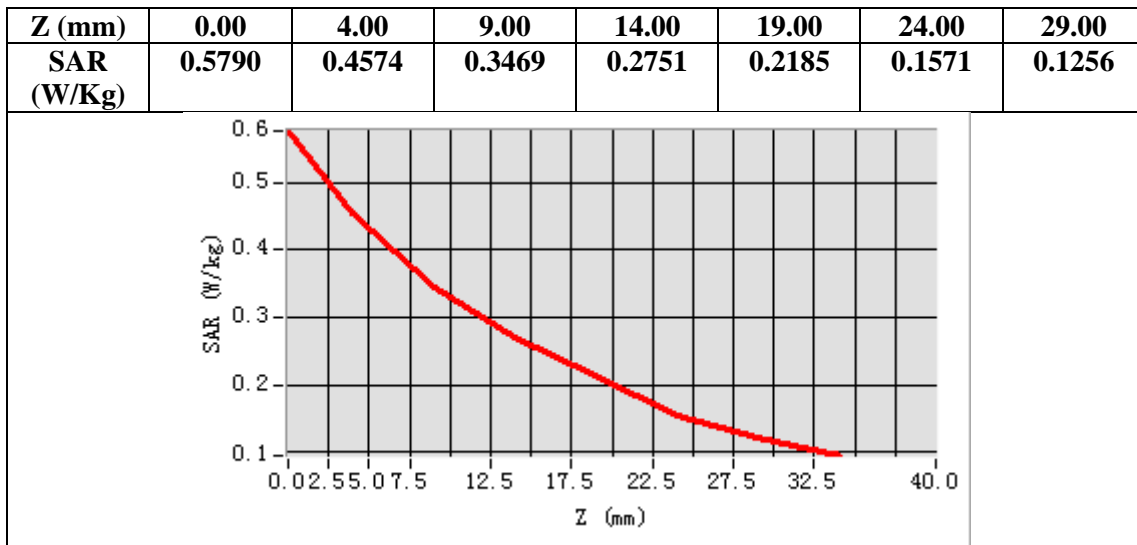

Test Laboratory: AGC Lab
GPRS 850 Mid - Body- Back (2up) <SIM 1>
DUT: Rugged Mobile Phone; Type: CS24SA

Date: July 02,2017

Communication System: GPRS-2 Slot; Communication System Band: GSM 850; Duty Cycle: 1:4.2; Conv.F=5.94;
Frequency: 836.6 MHz; Medium parameters used: $f = 835$ MHz; $\zeta = 0.97$ mho/m; $\epsilon_r = 55.21$; $\rho = 1000$ kg/m³ ;
Phantom section: Flat Section
Ambient temperature (°C): 21.9, Liquid temperature (°C): 21.5

SATIMO Configuration:

- Probe: SSE5; Calibrated: 12/05/2016; Serial No.: SN 14/16 EP308
- Sensor-Surface: 4mm (Mechanical Surface Detection)
- Phantom: SAM twin phantom
- Measurement SW: OpenSAR V4_02_32

Configuration/GPRS 850 Mid -Body-Back/Area Scan: Measurement grid: dx=8mm, dy=8mm
Configuration/GPRS 850 Mid -Body-Back/Zoom Scan: Measurement grid: dx=8mm,dy=8mm, dz=5mm;

Area Scan	sam_direct_droit2_surf8mm.txt
Zoom Scan	5x5x7,dx=8mm dy=8mm dz=5mm,Complete
Phantom	Validation plane
Device Position	Body Back
Band	GSM 850
Channels	Middle
Signal	TDMA (Crest factor: 4.0)

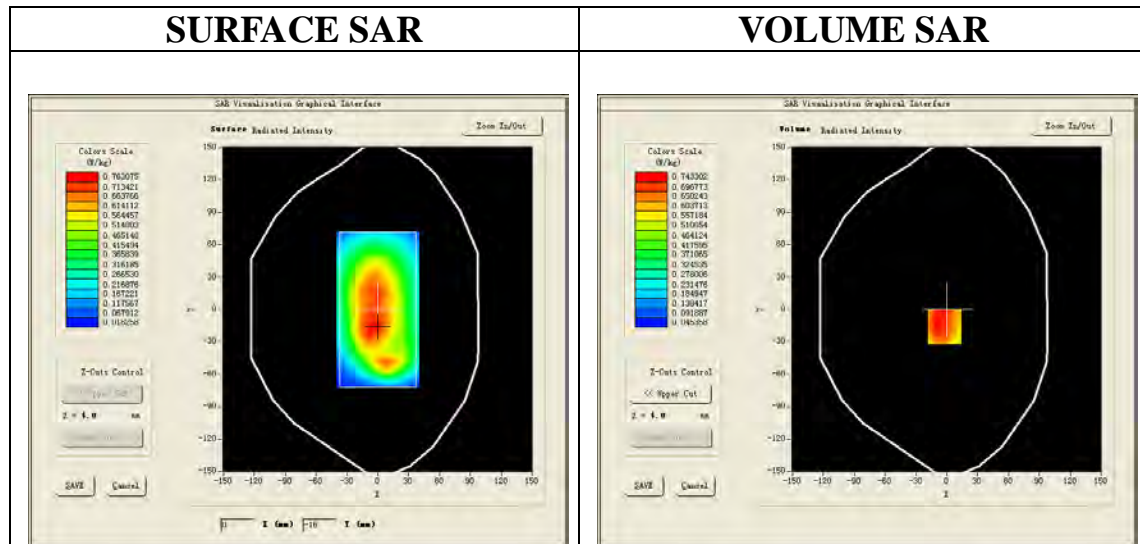

Maximum location: X=-2.00, Y=-16.00

SAR Peak: 1.01 W/kg

SAR 10g (W/Kg)	0.512521
SAR 1g (W/Kg)	0.729209

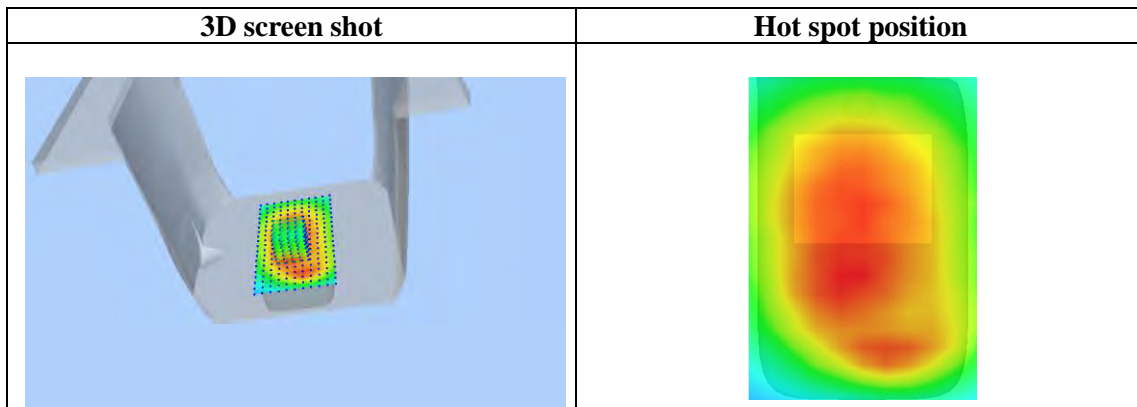
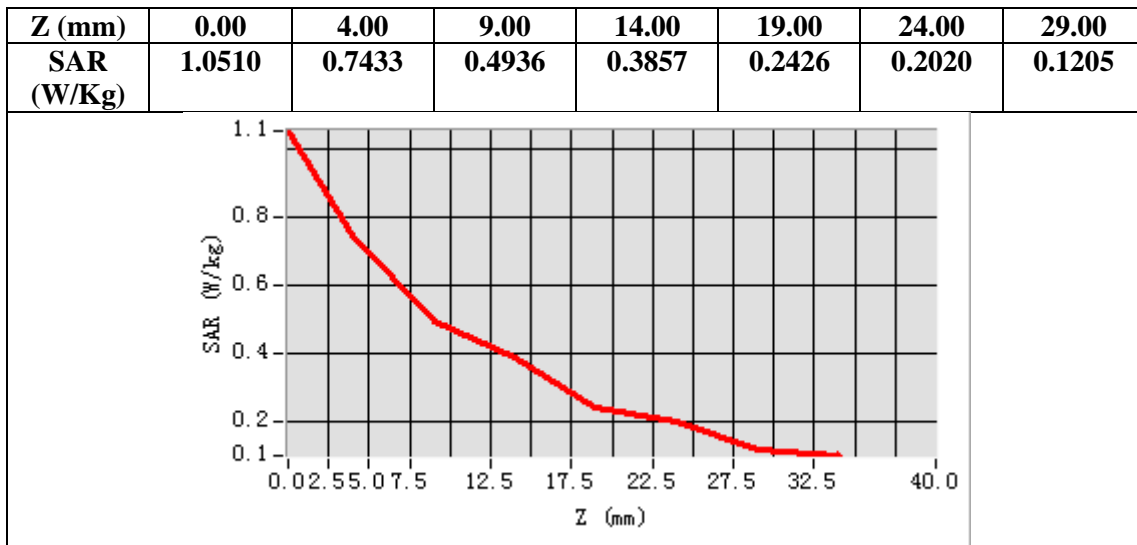

Test Laboratory: AGC Lab
GPRS 850 Mid-Touch-Right (2up) <SIM 2>
DUT: Rugged Mobile Phone; Type: CS24SA

Date: July 02,2017

Communication System: GPRS-2 Slot; Communication System Band: GSM 850; Duty Cycle: 1:4.2; Conv.F=5.72
Frequency: 836.6 MHz; Medium parameters used: $f = 835$ MHz; $\zeta = 0.91$ mho/m; $\epsilon_r = 41.23$; $\rho = 1000$ kg/m³;
Phantom section: Right Section
Ambient temperature (°C): 21.9, Liquid temperature (°C): 21.3

SATIMO Configuration:

- Probe: SSE5; Calibrated: 12/05/2016; Serial No.: SN 14/16 EP308
- Sensor-Surface: 4mm (Mechanical Surface Detection)
- Phantom: SAM twin phantom
- Measurement SW: OpenSAR V4_02_32

Configuration/GPRS 850 Mid-Touch-Right/Area Scan: Measurement grid: dx=8mm, dy=8mm
Configuration/GPRS 850 Mid-Touch-Right/Zoom Scan: Measurement grid: dx=8mm,dy=8mm, dz=5mm

Area Scan	sam_direct_droit2_surf8mm.txt
Zoom Scan	5x5x7,dx=8mm dy=8mm dz=5mm,Complete
Phantom	Right head
Device Position	Cheek
Band	GSM 850
Channels	Middle
Signal	TDMA (Crest factor: 4.0)

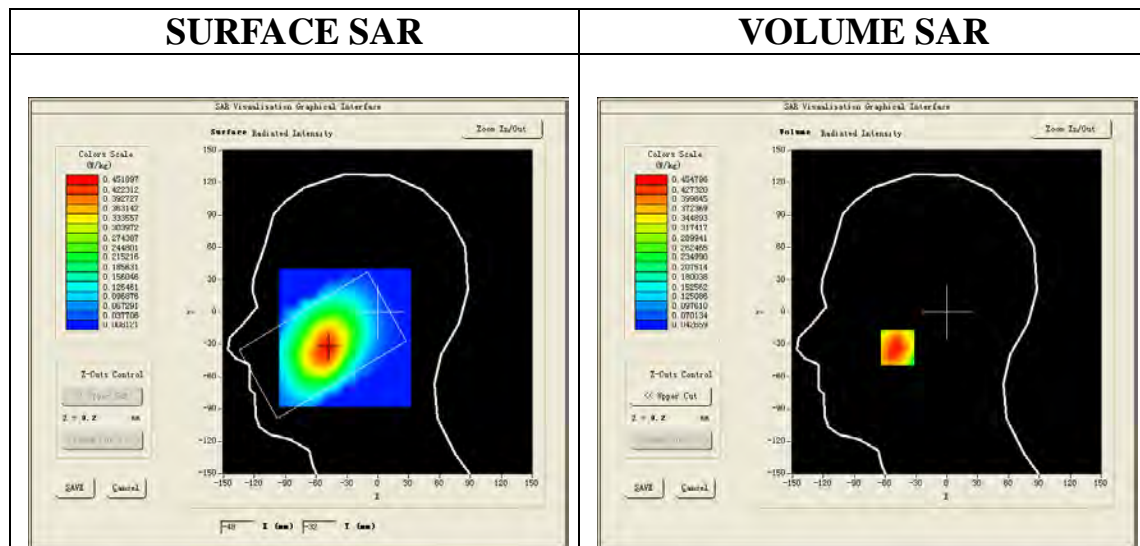

Maximum location: X=-48.00, Y=-33.00

SAR Peak: 0.59 W/kg

SAR 10g (W/Kg)	0.311686
SAR 1g (W/Kg)	0.442076

Z (mm)	0.00	4.00	9.00	14.00	19.00	24.00	29.00
SAR (W/Kg)	0.5765	0.4548	0.3448	0.2710	0.2122	0.1538	0.1221

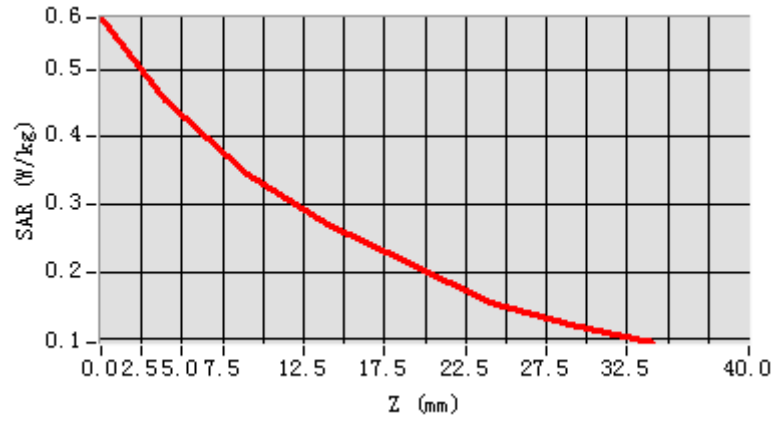

3D screen shot

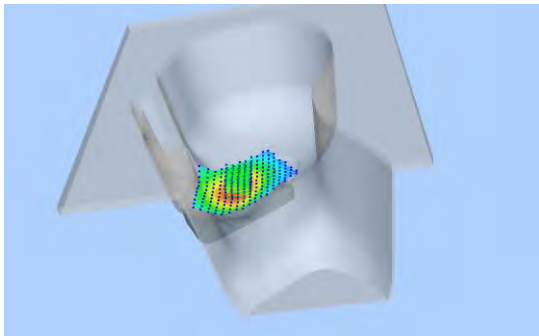

Hot spot position

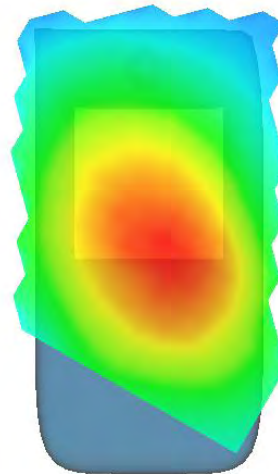

Test Laboratory: AGC Lab
GPRS 850 Mid - Body- Back (2up) <SIM 2>
DUT: Rugged Mobile Phone; Type: CS24SA

Date: July 02,2017

Communication System: GPRS-2 Slot; Communication System Band: GSM 850; Duty Cycle: 1:4.2; Conv.F=5.94;
Frequency: 836.6 MHz; Medium parameters used: $f = 835$ MHz; $\zeta = 0.97$ mho/m; $\epsilon_r = 55.21$; $\rho = 1000$ kg/m³ ;
Phantom section: Flat Section
Ambient temperature (°C): 21.9, Liquid temperature (°C): 21.5

SATIMO Configuration:

- Probe: SSE5; Calibrated: 12/05/2016; Serial No.: SN 14/16 EP308
- Sensor-Surface: 4mm (Mechanical Surface Detection)
- Phantom: SAM twin phantom
- Measurement SW: OpenSAR V4_02_32

Configuration/GPRS 850 Mid -Body-Back/Area Scan: Measurement grid: dx=8mm, dy=8mm
Configuration/GPRS 850 Mid -Body-Back/Zoom Scan: Measurement grid: dx=8mm,dy=8mm, dz=5mm;

Area Scan	sam_direct_droit2_surf8mm.txt
Zoom Scan	5x5x7,dx=8mm dy=8mm dz=5mm,Complete
Phantom	Validation plane
Device Position	Body Back
Band	GSM 850
Channels	Middle
Signal	TDMA (Crest factor: 4.0)

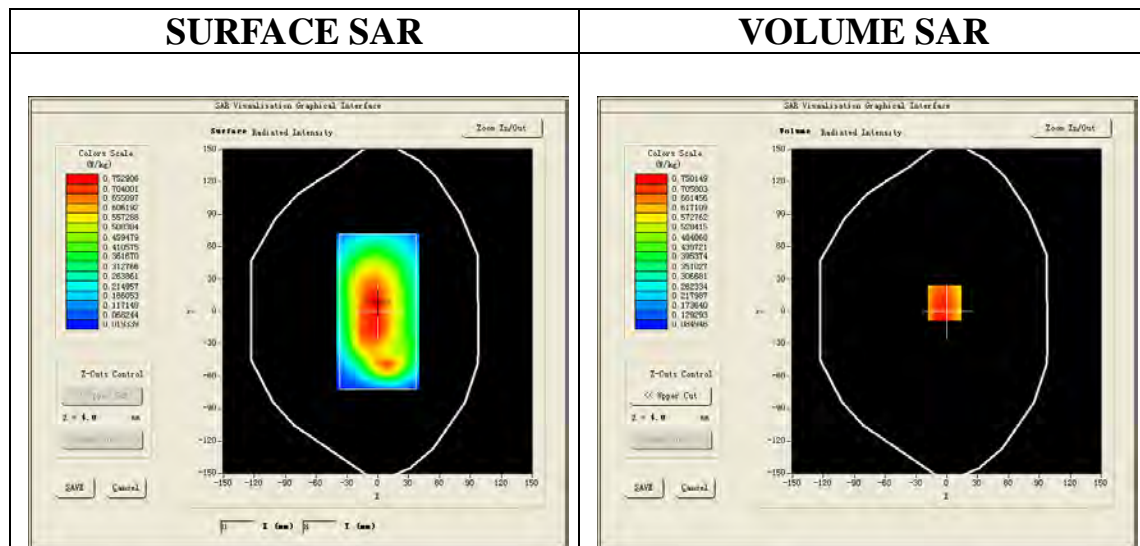

Maximum location: X=-2.00, Y=8.00
SAR Peak: 0.99 W/kg

SAR 10g (W/Kg)	0.520932
SAR 1g (W/Kg)	0.714266

Z (mm)	0.00	4.00	9.00	14.00	19.00	24.00	29.00
SAR (W/Kg)	0.9489	0.7501	0.5453	0.4447	0.3127	0.2283	0.1814

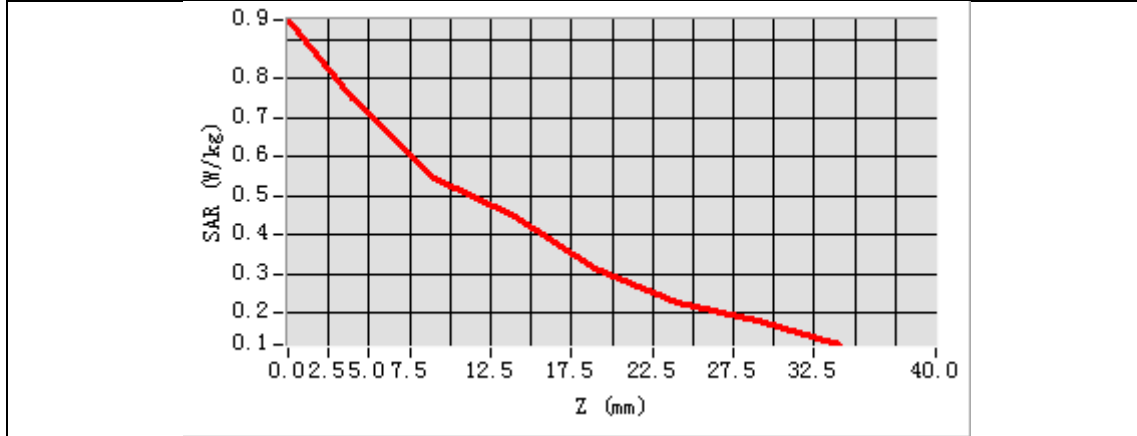

3D screen shot	Hot spot position

Test Laboratory: AGC Lab
PCS 1900 Mid-Touch- Left <SIM 1>
DUT: Rugged Mobile Phone; Type: CS24SA

Date: June 28, 2017

Communication System: Generic GSM; Communication System Band: PCS 1900; Duty Cycle: 1:8.3; Conv.F=5.14;
Frequency: 1880 MHz; Medium parameters used: $f = 1900$ MHz; $\zeta = 1.37$ mho/m; $\epsilon_r = 40.03$; $\rho = 1000$ kg/m³ ;
Phantom section: Left Section
Ambient temperature (°C): 22.1, Liquid temperature (°C): 21.3

SATIMO Configuration:

- Probe: SSE5; Calibrated: 07/05/2016; Serial No.: SN 14/16 EP307
- Sensor-Surface: 4mm (Mechanical Surface Detection)
- Phantom: SAM twin phantom
- Measurement SW: OpenSAR V4_02_35

Configuration/PCS1900 Mid-Touch-Left/Area Scan: Measurement grid: dx=8mm, dy=8mm
Configuration/PCS1900 Mid-Touch-Left/Zoom Scan: Measurement grid: dx=8mm,dy=8mm, dz=5mm;

Area Scan	sam_direct_droit2_surf8mm.txt
ZoomScan	5x5x7,dx=8mm dy=8mm dz=5mm,Complete
Phantom	Left head
Device Position	Cheek
Band	PCS 1900
Channels	Middle
Signal	TDMA (Crest factor: 8.0)

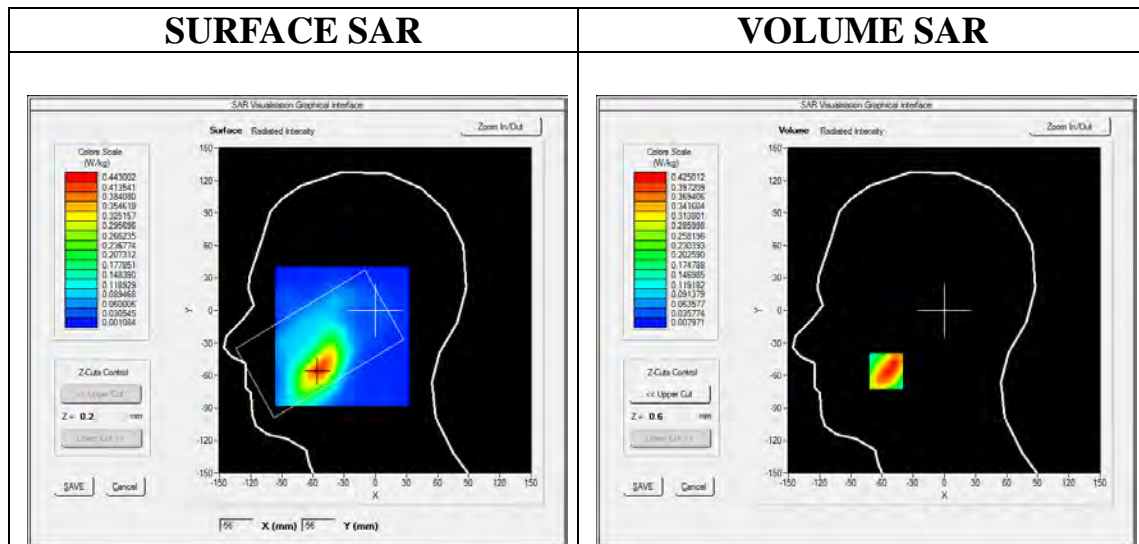

Maximum location: X=-56.00, Y=-56.00

SAR Peak: 0.66 W/kg

SAR 10g (W/Kg)	0.236142
SAR 1g (W/Kg)	0.412823

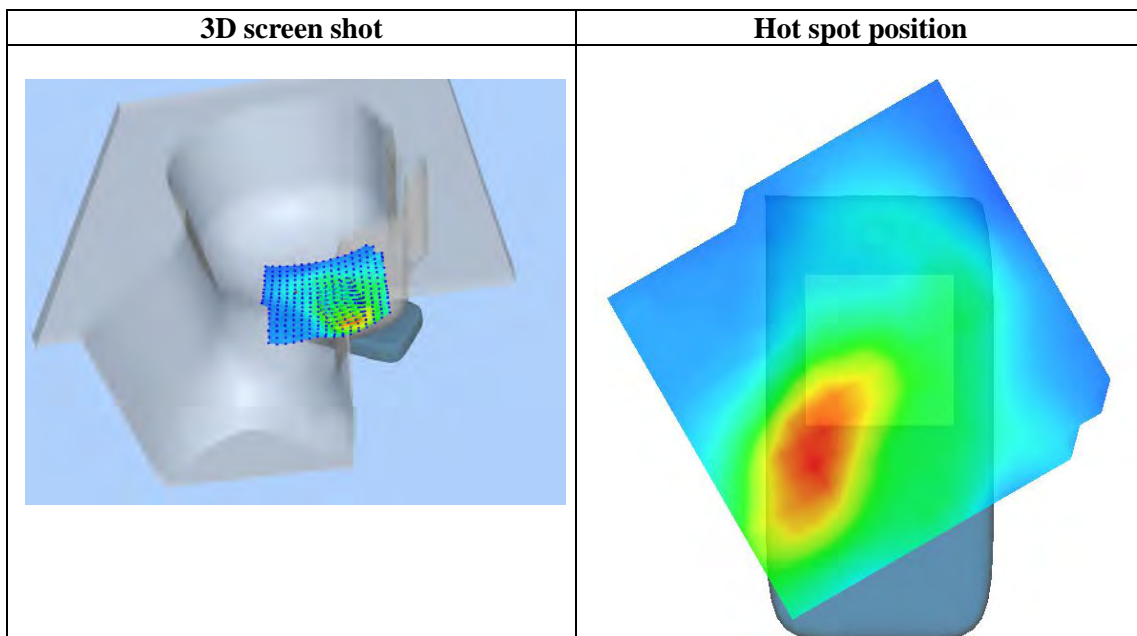
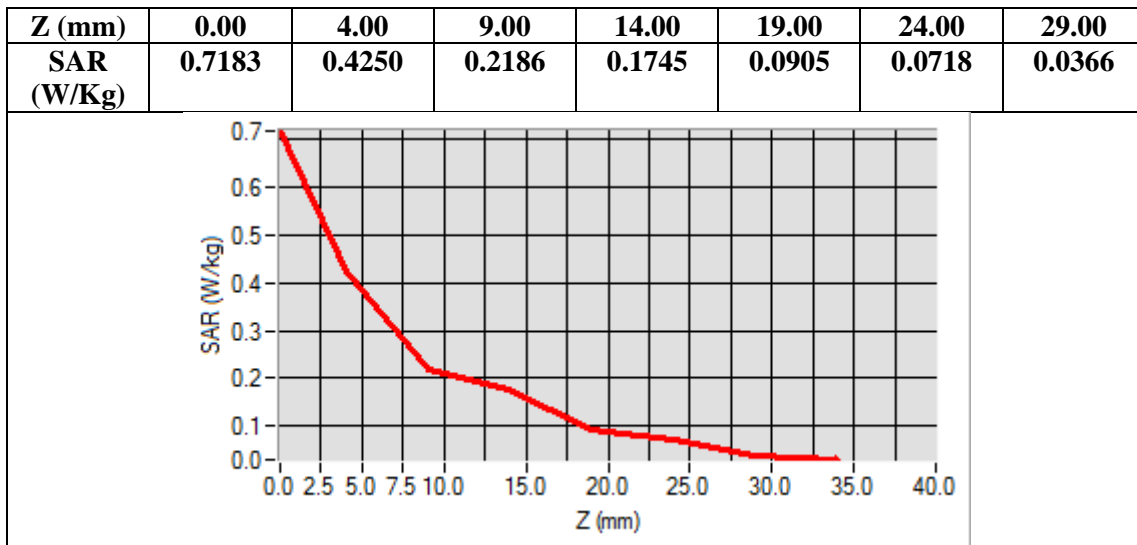

Test Laboratory: AGC Lab
PCS 1900 Mid-Body-Back (MS)<SIM 1>
DUT: Rugged Mobile Phone; Type: CS24SA

Date: June 28, 2017

Communication System: Generic GSM; Communication System Band: PCS 1900; Duty Cycle: 1:8.3; Conv.F=5.34;
Frequency: 1880 MHz; Medium parameters used: $f = 1900$ MHz; $\zeta = 1.49$ mho/m; $\epsilon_r = 54.02$; $\rho = 1000$ kg/m³ ;
Phantom section: Flat Section
Ambient temperature (°C): 22.1, Liquid temperature (°C): 21.5

SATIMO Configuration:

- Probe: SSE5; Calibrated: 07/05/2016; Serial No.: SN 14/16 EP307
- Sensor-Surface: 4mm (Mechanical Surface Detection)
- Phantom: SAM twin phantom
- Measurement SW: OpenSAR V4_02_35

Configuration/PCS1900 Mid-Body-Back/Area Scan: Measurement grid: dx=8mm, dy=8mm
Configuration/PCS1900 Mid-Body-Back/Zoom Scan: Measurement grid: dx=8mm, dy=8mm, dz=5mm;

Area Scan	sam_direct_droit2_surf8mm.txt
ZoomScan	5x5x7,dx=8mm dy=8mm dz=5mm,Complete
Phantom	Validation plane
Device Position	Body Back
Band	PCS 1900
Channels	Middle
Signal	TDMA (Crest factor: 8.0)

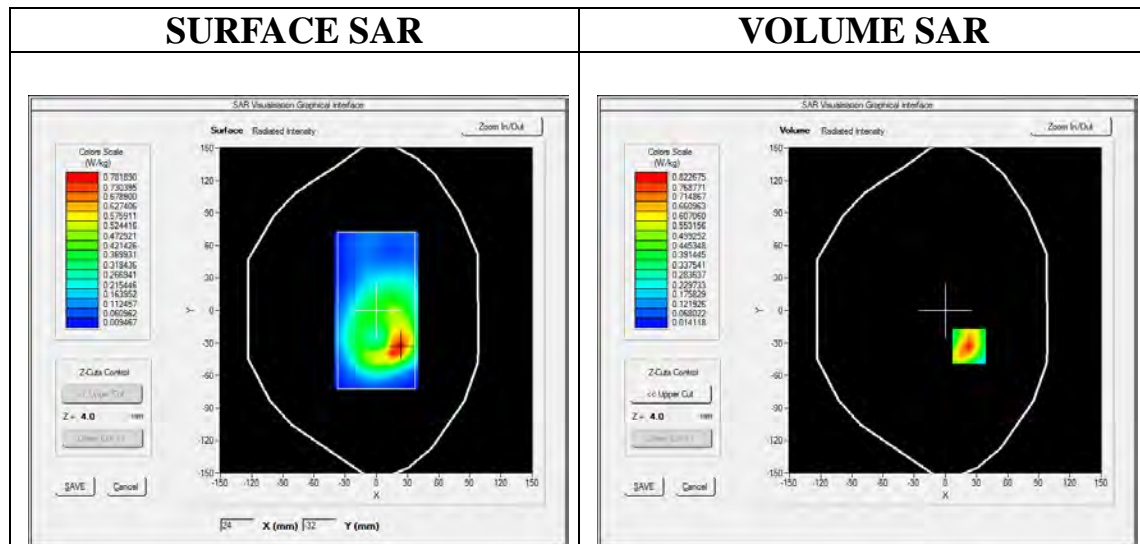

Maximum location: X=23.00, Y=-33.00

SAR Peak: 1.39 W/kg

SAR 10g (W/Kg)	0.392707
SAR 1g (W/Kg)	0.769245

Z (mm)	0.00	4.00	9.00	14.00	19.00	24.00	29.00
SAR (W/Kg)	1.4145	0.8227	0.4014	0.2505	0.1320	0.0818	0.0442

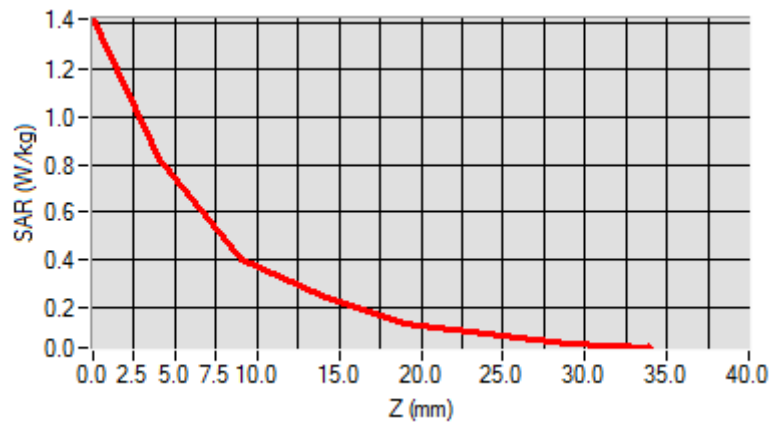

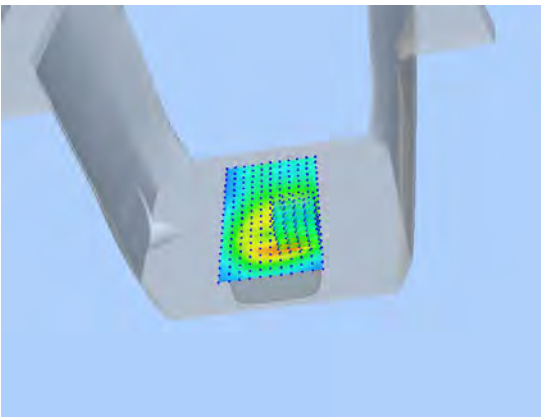
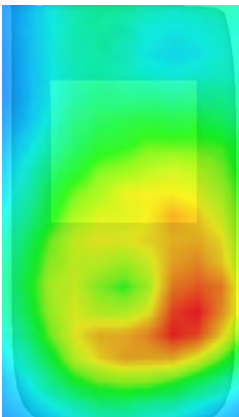
3D screen shot	Hot spot position
	

Test Laboratory: AGC Lab
GPRS 1900 Mid-Touch- Left (2up) <SIM 1>
DUT: Rugged Mobile Phone; Type: CS24SA

Date: June 28, 2017

Communication System: GPRS-2Slot; Communication System Band: PCS 1900; Duty Cycle: 1:4.2; Conv.F=5.14;
Frequency: 1880 MHz; Medium parameters used: $f = 1900$ MHz; $\zeta = 1.37$ mho/m; $\epsilon_r = 40.03$; $\rho = 1000$ kg/m³ ;
Phantom section: Left Section
Ambient temperature (°C): 22.1, Liquid temperature (°C): 21.3

SATIMO Configuration:

- Probe: SSE5; Calibrated: 07/05/2016; Serial No.: SN 14/16 EP307
- Sensor-Surface: 4mm (Mechanical Surface Detection)
- Phantom: SAM twin phantom
- Measurement SW: OpenSAR V4_02_35

Configuration/GPRS1900 Mid-Touch-Left/Area Scan: Measurement grid: dx=8mm, dy=8mm
Configuration/GPRS1900 Mid-Touch-Left/Zoom Scan: Measurement grid: dx=8mm, dy=8mm, dz=5mm;

Area Scan	sam_direct_droit2_surf8mm.txt
Zoom Scan	5x5x7,dx=8mm dy=8mm dz=5mm,Complete
Phantom	Left head
Device Position	Cheek
Band	PCS 1900
Channels	Middle
Signal	TDMA (Crest factor: 4.0)

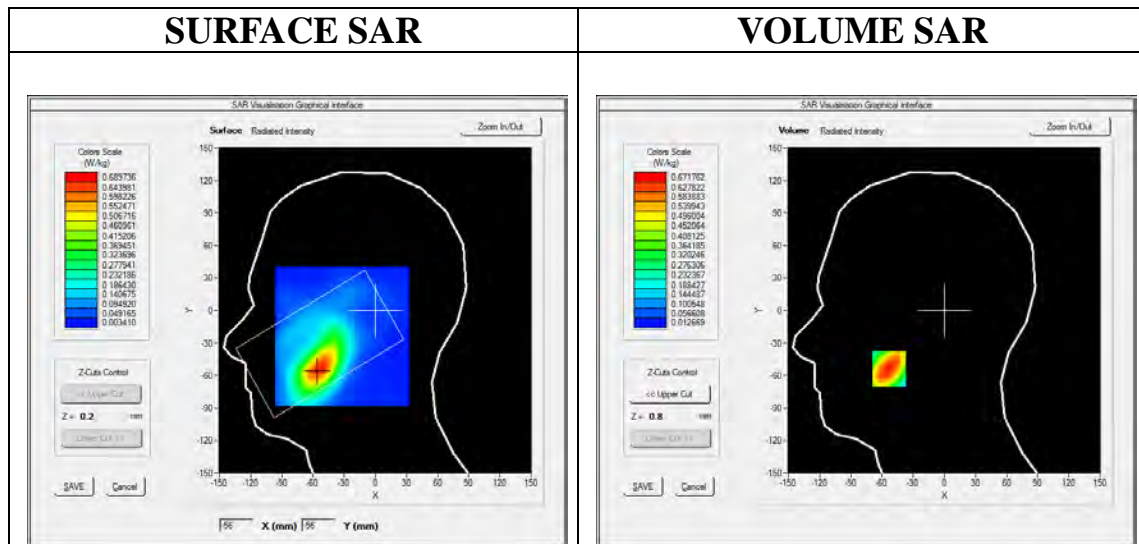

Maximum location: X=-53.00, Y=-54.00

SAR Peak: 0.98 W/kg

SAR 10g (W/Kg)	0.376488
SAR 1g (W/Kg)	0.638360

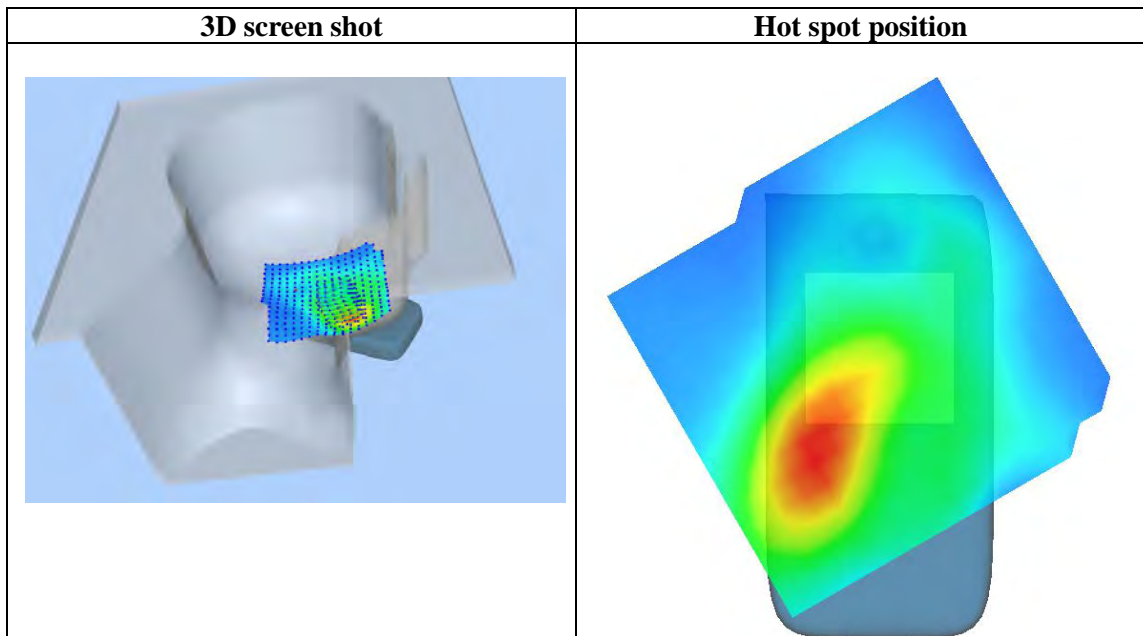
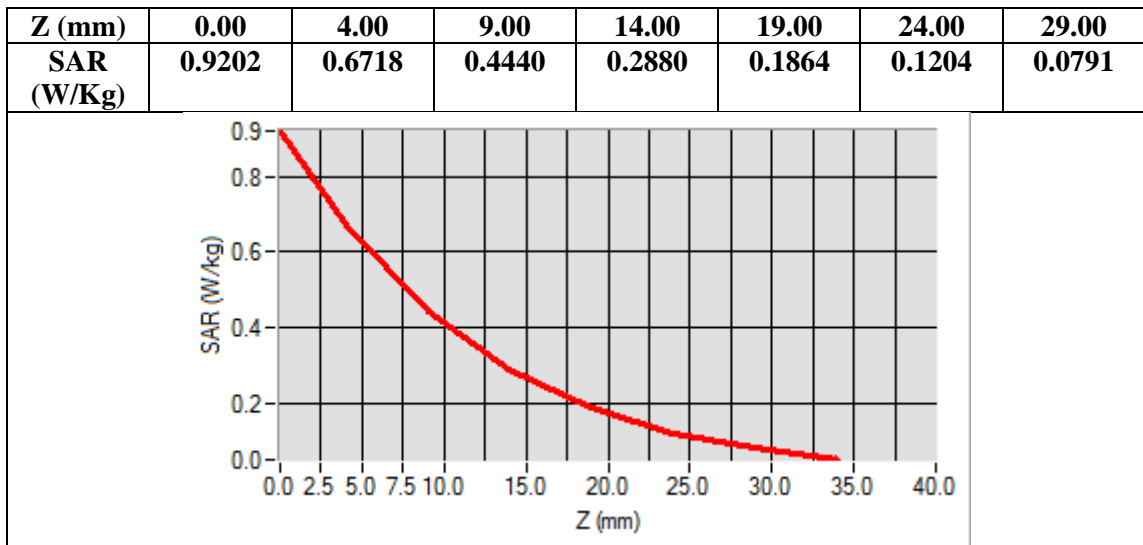

Test Laboratory: AGC Lab
GPRS 1900 Low-Body-Front (2up) <SIM 1>
DUT: Rugged Mobile Phone; Type: CS24SA

Date: June 28, 2017

Communication System: GPRS-2Slot; Communication System Band: PCS 1900; Duty Cycle: 1:4.2; Conv.F=5.34;
Frequency: 1850.2MHz; Medium parameters used: $f = 1900$ MHz; $\zeta = 1.45$ mho/m; $\epsilon_r = 55.15$; $\rho = 1000$ kg/m³ ;
Phantom section: Flat Section
Ambient temperature (°C): 22.1, Liquid temperature (°C): 21.5

SATIMO Configuration:

- Probe: SSE5; Calibrated: 07/05/2016; Serial No.: SN 14/16 EP307
- Sensor-Surface: 4mm (Mechanical Surface Detection)
- Phantom: SAM twin phantom
- Measurement SW: OpenSAR V4_02_35

Configuration/GPRS1900 Low -Body- Front /Area Scan: Measurement grid: dx=8mm, dy=8mm
Configuration/GPRS1900 Low -Body- Front /Zoom Scan: Measurement grid: dx=8mm,dy=8mm, dz=5mm;

Area Scan	sam_direct_droit2_surf8mm.txt
Zoom Scan	5x5x7,dx=8mm dy=8mm dz=5mm,Complete
Phantom	Validation plane
Device Position	Body Front
Band	PCS 1900
Channels	Low
Signal	TDMA (Crest factor: 4.0)

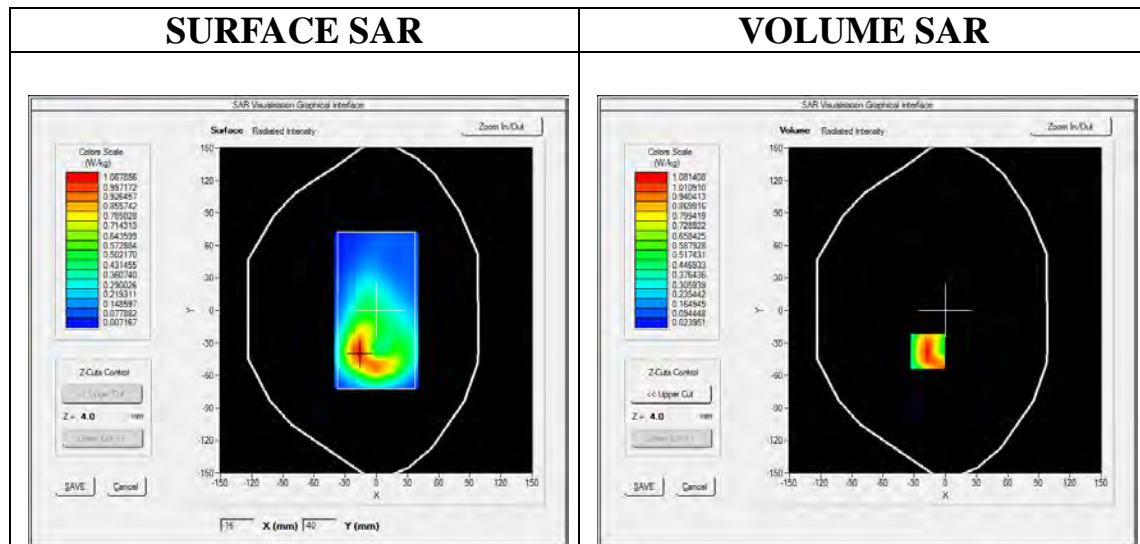

Maximum location: X=-17.00, Y=-38.00

SAR Peak: 1.68 W/kg

SAR 10g (W/Kg)	0.558305
SAR 1g (W/Kg)	1.026124

Z (mm)	0.00	4.00	9.00	14.00	19.00	24.00	29.00
SAR (W/Kg)	1.6673	1.0859	0.6179	0.3562	0.2046	0.1253	0.0758

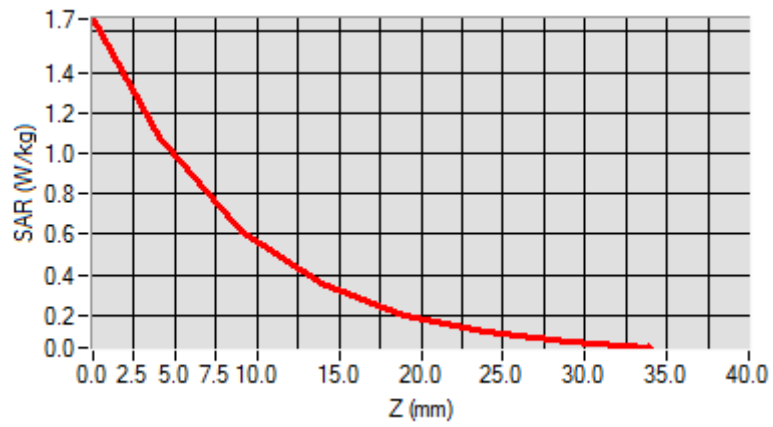

3D screen shot	Hot spot position
<p>A 3D perspective view of a grey, L-shaped device. A rectangular area on the inner surface is highlighted with a color-coded heatmap, showing a gradient from blue (low SAR) to red (high SAR), indicating the location of the maximum SAR value.</p>	<p>A 2D top-down view of the device's surface. A color heatmap is overlaid, with the highest intensity (red) concentrated in a circular region at the bottom center, representing the hot spot position.</p>

Test Laboratory: AGC Lab
GPRS 1900 Mid-Touch- Left (2up) <SIM 2>
DUT: Rugged Mobile Phone; Type: CS24SA

Date: June 28, 2017

Communication System: GPRS-2Slot; Communication System Band: PCS 1900; Duty Cycle: 1:4.2; Conv.F=5.14;
Frequency: 1880 MHz; Medium parameters used: $f = 1900$ MHz; $\zeta = 1.37$ mho/m; $\epsilon_r = 40.03$; $\rho = 1000$ kg/m³ ;
Phantom section: Left Section
Ambient temperature (°C): 22.1, Liquid temperature (°C): 21.3

SATIMO Configuration:

- Probe: SSE5; Calibrated: 07/05/2016; Serial No.: SN 14/16 EP307
- Sensor-Surface: 4mm (Mechanical Surface Detection)
- Phantom: SAM twin phantom
- Measurement SW: OpenSAR V4_02_35

Configuration/GPRS1900 Mid-Touch-Left/Area Scan: Measurement grid: dx=8mm, dy=8mm
Configuration/GPRS1900 Mid-Touch-Left/Zoom Scan: Measurement grid: dx=8mm, dy=8mm, dz=5mm;

Area Scan	sam_direct_droit2_surf8mm.txt
Zoom Scan	5x5x7,dx=8mm dy=8mm dz=5mm,Complete
Phantom	Left head
Device Position	Cheek
Band	PCS 1900
Channels	Middle
Signal	TDMA (Crest factor: 4.0)

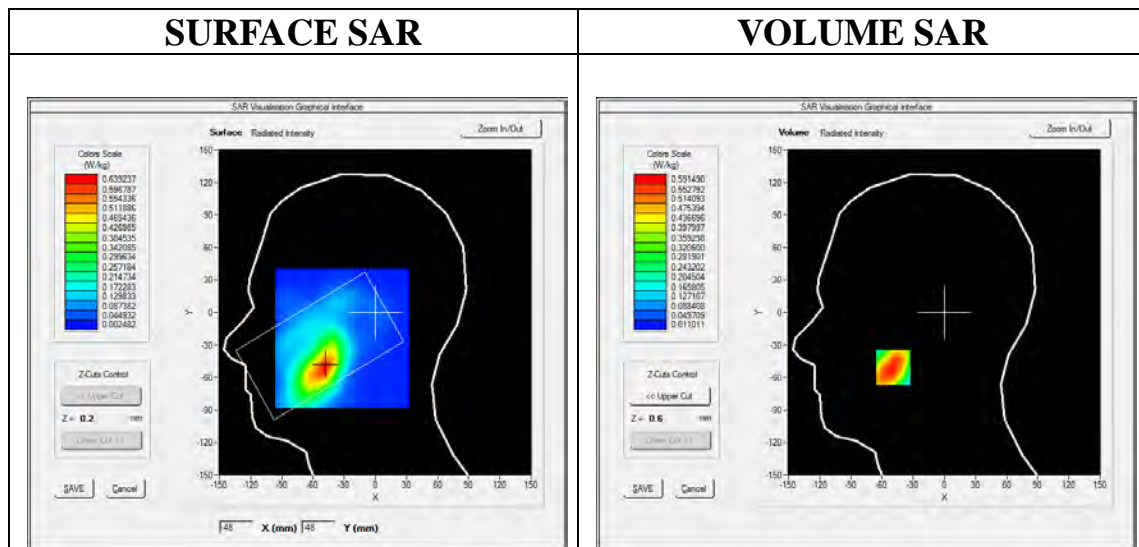

Maximum location: X=-49.00, Y=-51.00

SAR Peak: 0.86 W/kg

SAR 10g (W/Kg)	0.341329
SAR 1g (W/Kg)	0.571188

Z (mm)	0.00	4.00	9.00	14.00	19.00	24.00	29.00
SAR (W/Kg)	0.8491	0.5915	0.3832	0.2670	0.1830	0.1148	0.0758

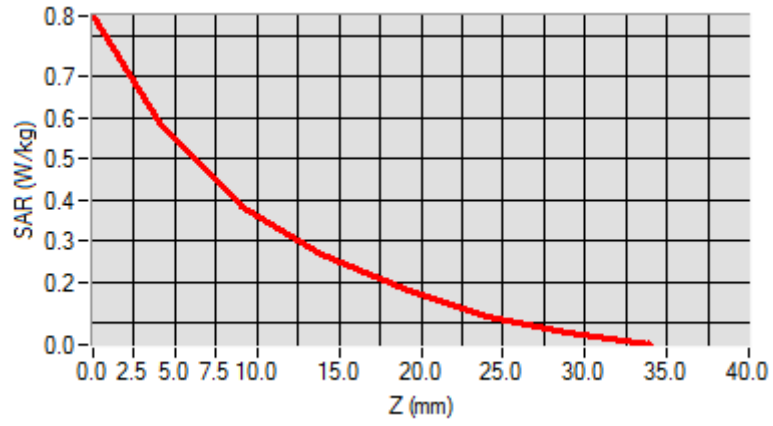

3D screen shot

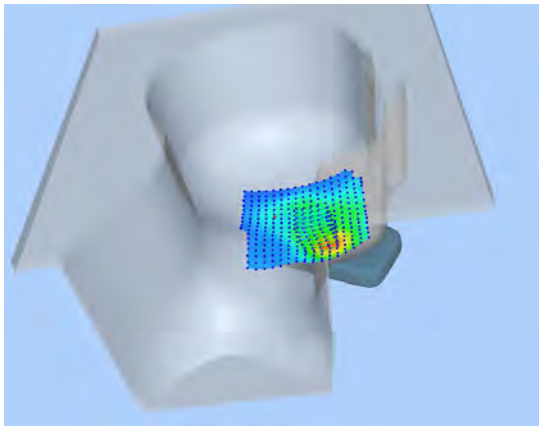

Hot spot position

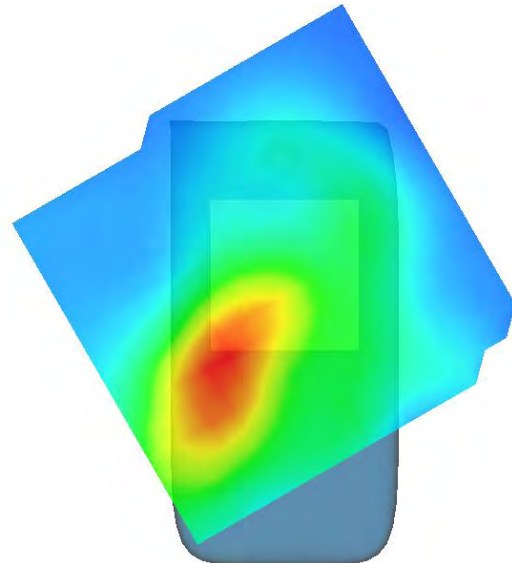

Test Laboratory: AGC Lab
GPRS 1900 Low-Body-Front (2up) <SIM 2>
DUT: Rugged Mobile Phone; Type: CS24SA

Date: June 28, 2017

Communication System: GPRS-2Slot; Communication System Band: PCS 1900; Duty Cycle: 1:4.2; Conv.F=5.34;
Frequency: 1850.2MHz; Medium parameters used: $f = 1900$ MHz; $\zeta = 1.45$ mho/m; $\epsilon_r = 55.15$; $\rho = 1000$ kg/m³ ;
Phantom section: Flat Section
Ambient temperature (°C): 22.1, Liquid temperature (°C): 21.5

SATIMO Configuration:

- Probe: SSE5; Calibrated: 07/05/2016; Serial No.: SN 14/16 EP307
- Sensor-Surface: 4mm (Mechanical Surface Detection)
- Phantom: SAM twin phantom
- Measurement SW: OpenSAR V4_02_35

Configuration/GPRS1900 Low -Body- Front /Area Scan: Measurement grid: dx=8mm, dy=8mm
Configuration/GPRS1900 Low -Body- Front /Zoom Scan: Measurement grid: dx=8mm,dy=8mm, dz=5mm;

Area Scan	sam_direct_droit2_surf8mm.txt
Zoom Scan	5x5x7,dx=8mm dy=8mm dz=5mm,Complete
Phantom	Validation plane
Device Position	Body Front
Band	PCS 1900
Channels	Low
Signal	TDMA (Crest factor: 4.0)

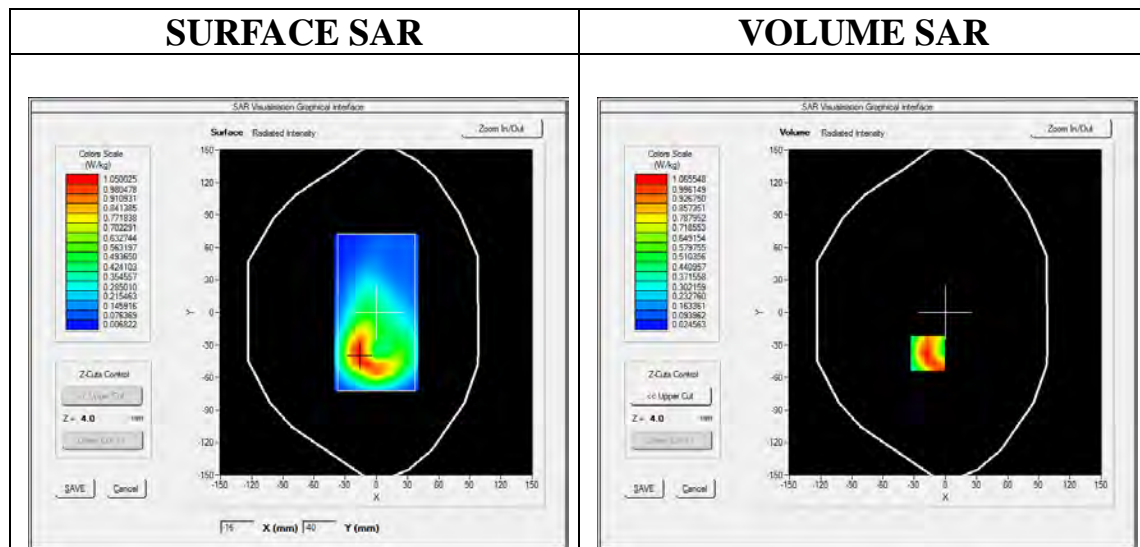

Maximum location: X=-17.00, Y=-38.00

SAR Peak: 1.68 W/kg

SAR 10g (W/Kg)	0.558925
SAR 1g (W/Kg)	1.018181

Z (mm)	0.00	4.00	9.00	14.00	19.00	24.00	29.00
SAR (W/Kg)	1.6451	1.0655	0.6064	0.3723	0.2126	0.1237	0.0713

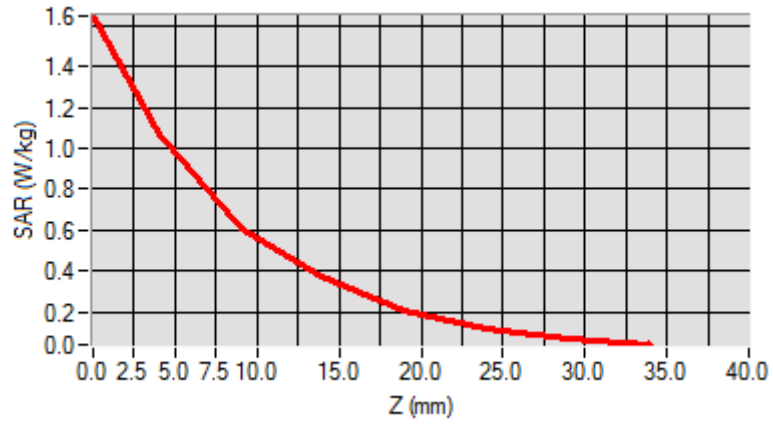

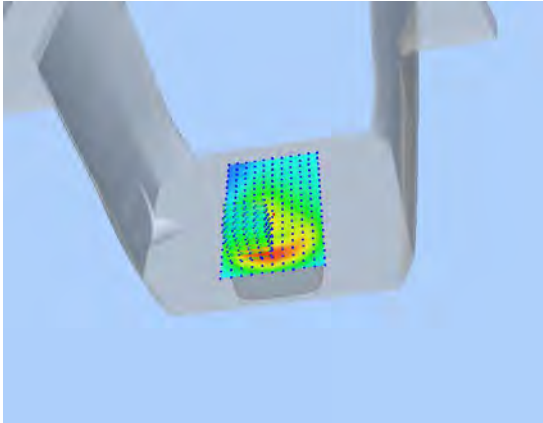
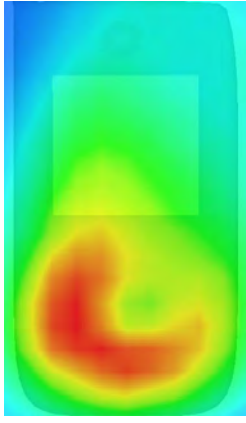
3D screen shot	Hot spot position
	

Test Laboratory: AGC Lab
WCDMA Band II Mid-Touch-Left (RMC)
DUT: Rugged Mobile Phone; Type: CS24SA

Date: June 28, 2017

Communication System: UMTS; Communication System Band: Band II UTRA/FDD ;Duty Cycle:1:1; Conv.F=5.14;
Frequency: 1880 MHz; Medium parameters used: $f = 1900$ MHz; $\zeta = 1.37$ mho/m; $\epsilon_r = 40.03$; $\rho = 1000$ kg/m³ ;
Phantom section: Left Section
Ambient temperature (°C): 22.1, Liquid temperature (°C): 21.3

SATIMO Configuration:

- Probe: SSE5; Calibrated: 07/05/2016; Serial No.: SN 14/16 EP307
- Sensor-Surface: 4mm (Mechanical Surface Detection)
- Phantom: SAM twin phantom
- Measurement SW: OpenSAR V4_02_35

Configuration/WCDMA band II Mid-Touch-Left/Area Scan: Measurement grid: dx=8mm, dy=8mm

Configuration/WCDMA band II Mid-Touch-Left/Zoom Scan: Measurement grid: dx=8mm,dy=8mm, dz=5mm;

Area Scan	sam_direct_droit2_surf8mm.txt
ZoomScan	5x5x7,dx=8mm dy=8mm dz=5mm,Complete
Phantom	Left head
Device Position	Cheek
Band	WCDMA band II
Channels	Middle
Signal	CDMA (Crest factor: 1.0)

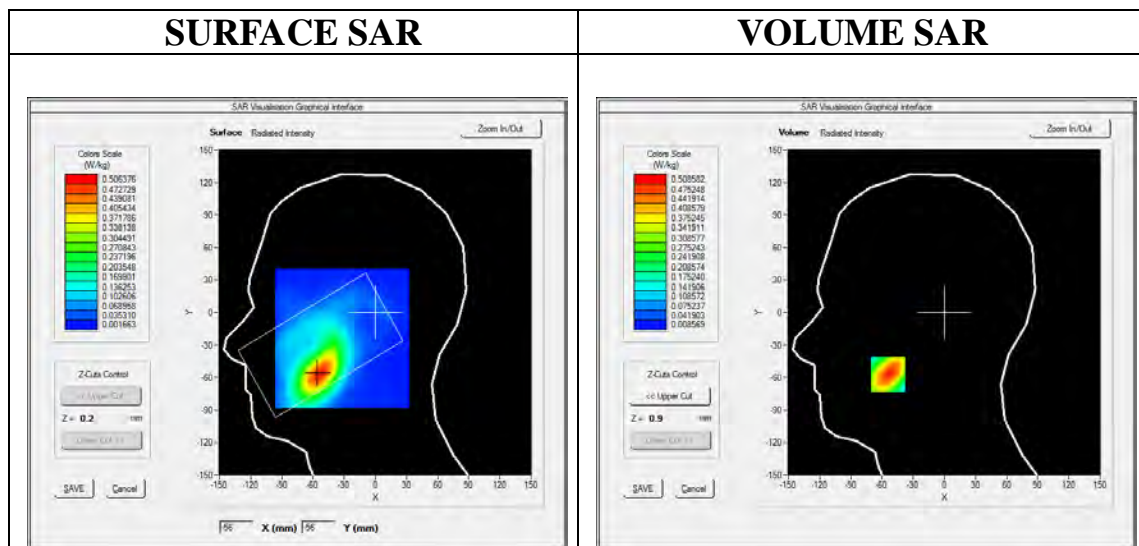

Maximum location: X=-54.00, Y=-57.00

SAR Peak: 0.74 W/kg

SAR 10g (W/Kg)	0.276507
SAR 1g (W/Kg)	0.481110

Z (mm)	0.00	4.00	9.00	14.00	19.00	24.00	29.00
SAR (W/Kg)	0.7347	0.5086	0.3190	0.2040	0.1312	0.0868	0.0567

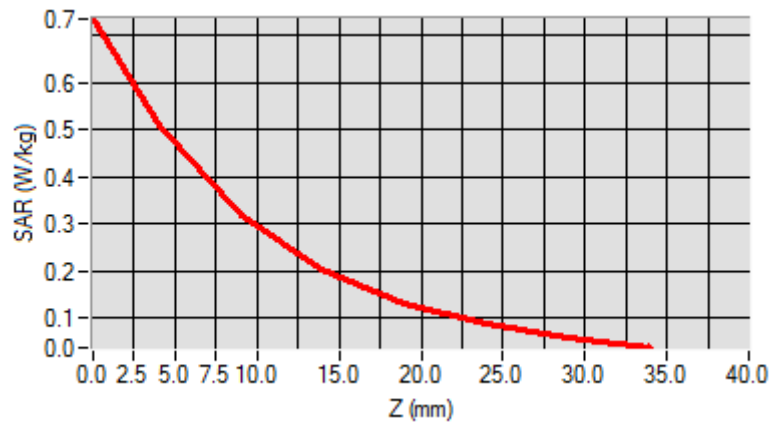

3D screen shot

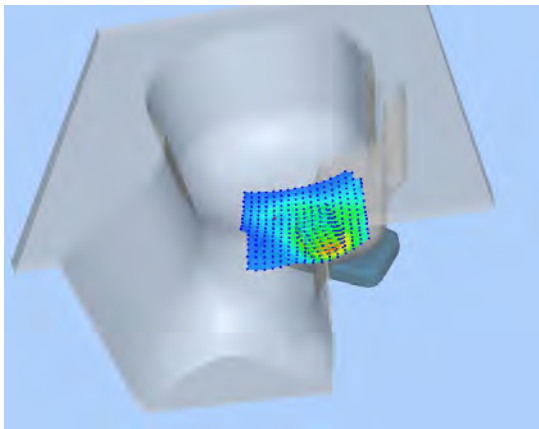

Hot spot position

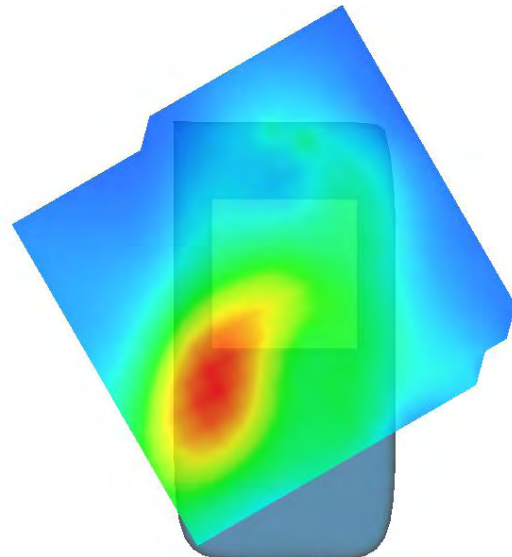

Test Laboratory: AGC Lab
WCDMA Band II Low-Body-Towards Phantom (RMC 12.2kbps)
DUT: Rugged Mobile Phone; Type: CS24SA

Date: June 28, 2017

Communication System: UMTS; Communication System Band: Band II UTRA/FDD ;Duty Cycle:1:1; Conv.F=5.34;
Frequency: 1852.4 MHz; Medium parameters used: $f = 1900$ MHz; $\zeta = 1.47$ mho/m; $\epsilon_r = 54.67$; $\rho = 1000$ kg/m³ ;
Phantom section: Flat Section
Ambient temperature (°C): 22.1, Liquid temperature (°C): 21.5

SATIMO Configuration:

- Probe: SSE5; Calibrated: 07/05/2016; Serial No.: SN 14/16 EP307
- Sensor-Surface: 4mm (Mechanical Surface Detection)
- Phantom: SAM twin phantom
- Measurement SW: OpenSAR V4_02_35

Configuration/ WCDMA band II Low-Body-Front /Area Scan: Measurement grid: dx=8mm, dy=8mm
Configuration/ WCDMA band II Low-Body-Front /Zoom Scan: Measurement grid: dx=8mm,dy=8mm, dz=5mm;

Area Scan	sam_direct_droit2_surf8mm.txt
ZoomScan	5x5x7,dx=8mm dy=8mm dz=5mm,Complete
Phantom	Validation plane
Device Position	Body Front
Band	WCDMA band II
Channels	Low
Signal	CDMA (Crest factor: 1.0)

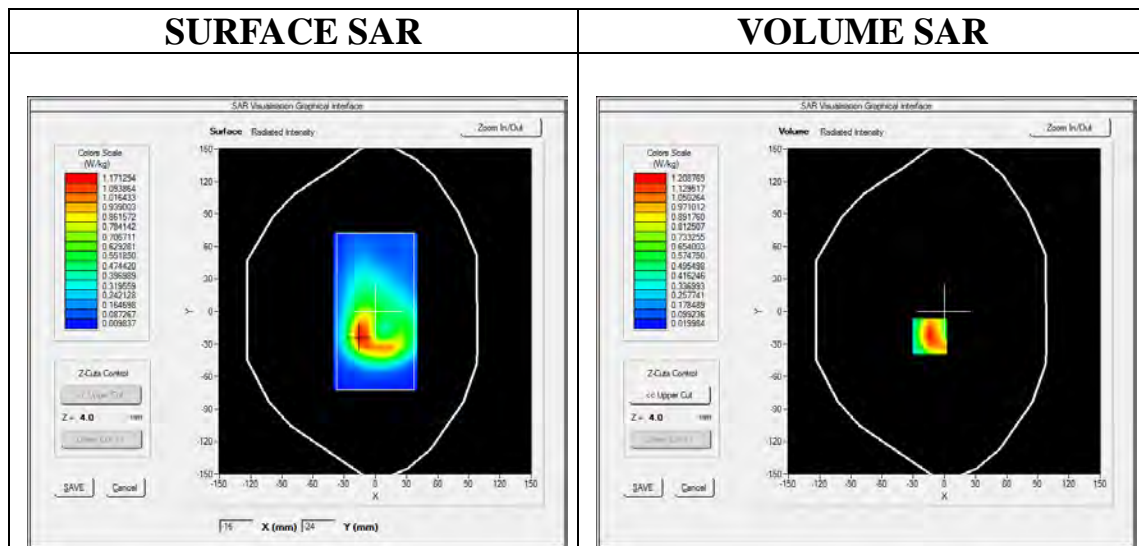

Maximum location: X=-14.00, Y=-23.00

SAR Peak: 1.92 W/kg

SAR 10g (W/Kg)	0.606284
SAR 1g (W/Kg)	1.144450

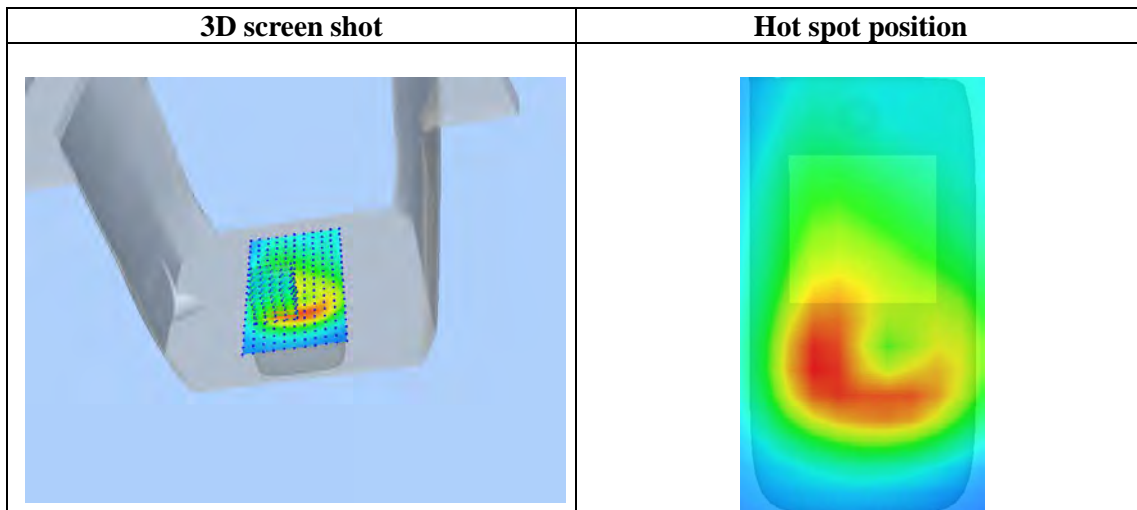
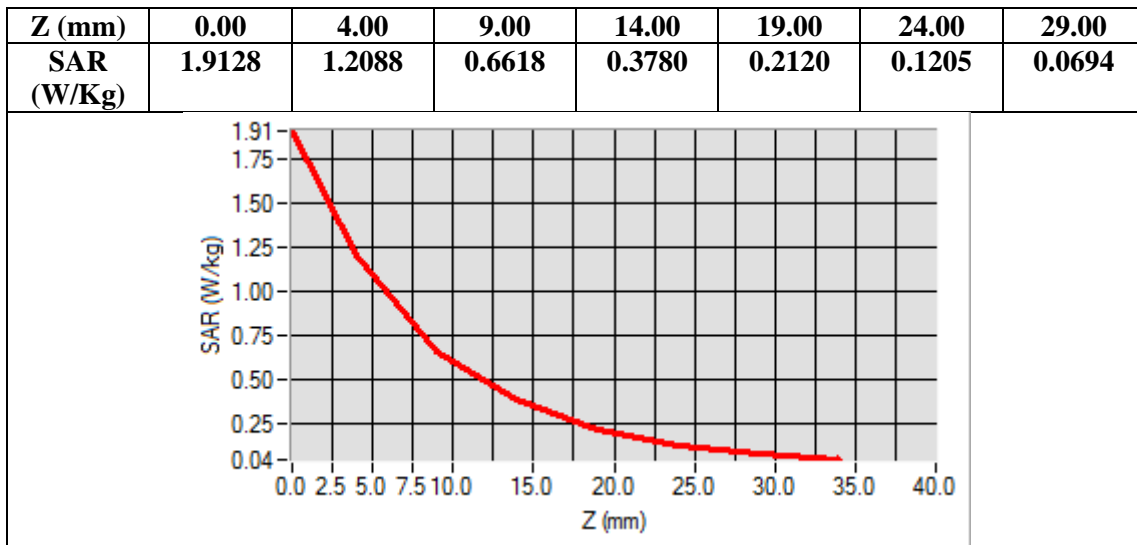

Test Laboratory: AGC Lab
WCDMA Band IV Mid-Touch-Left (RMC)
DUT: Rugged Mobile Phone; Type: CS24SA

Date: July 02,2017

Communication System: UMTS; Communication System Band: BAND IV UTRA/FDD; Duty Cycle:1: 1; Conv.F=4.92;
Frequency:1732.5 MHz; Medium parameters used: $f = 1750$ MHz; $\zeta = 1.35$ mho/m; $\epsilon_r = 41.03$; $\rho = 1000$ kg/m³ ;
Phantom section: Left Section
Ambient temperature (°C): 22.1, Liquid temperature (°C): 21.3

SATIMO Configuration:

- Probe: SSE5; Calibrated: 07/05/2016; Serial No.: SN 14/16 EP307
- Sensor-Surface: 4mm (Mechanical Surface Detection)
- Phantom: SAM twin phantom
- Measurement SW: OpenSAR V4_02_35

Configuration/ WCDMA Band IV Mid-Touch-Left/Area Scan: Measurement grid: dx=8mm, dy=8mm
Configuration/ WCDMA Band IV Mid-Touch-Left/Zoom Scan: Measurement grid: dx=8mm, dy=8mm, dz=5mm

Area Scan	sam_direct_droit2_surf8mm.txt
ZoomScan	5x5x7,dx=8mm dy=8mm dz=5mm,Complete
Phantom	Left head
Device Position	Cheek
Band	WCDMA Band IV
Channels	Middle
Signal	CDMA (Crest factor: 1.0)

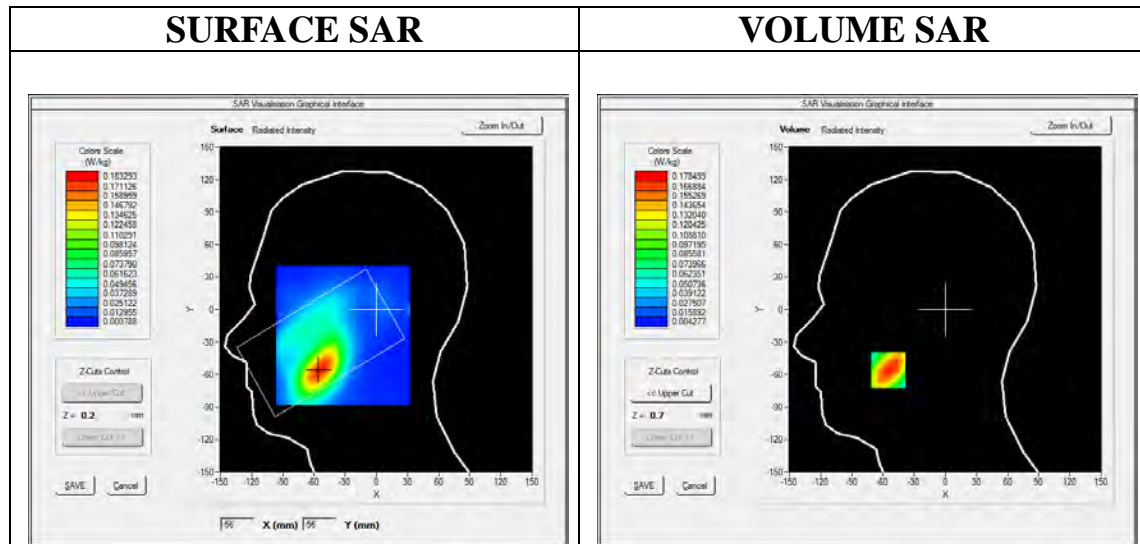

Maximum location: X=-55.00, Y=-56.00

SAR Peak: 0.25 W/kg

SAR 10g (W/Kg)	0.099935
SAR 1g (W/Kg)	0.169366

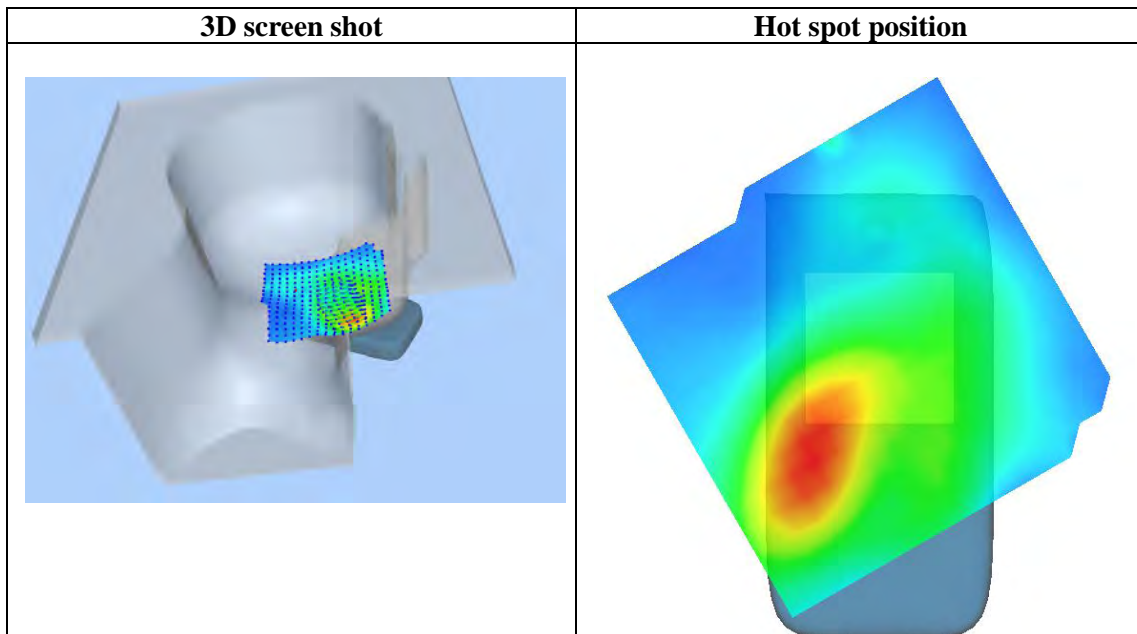
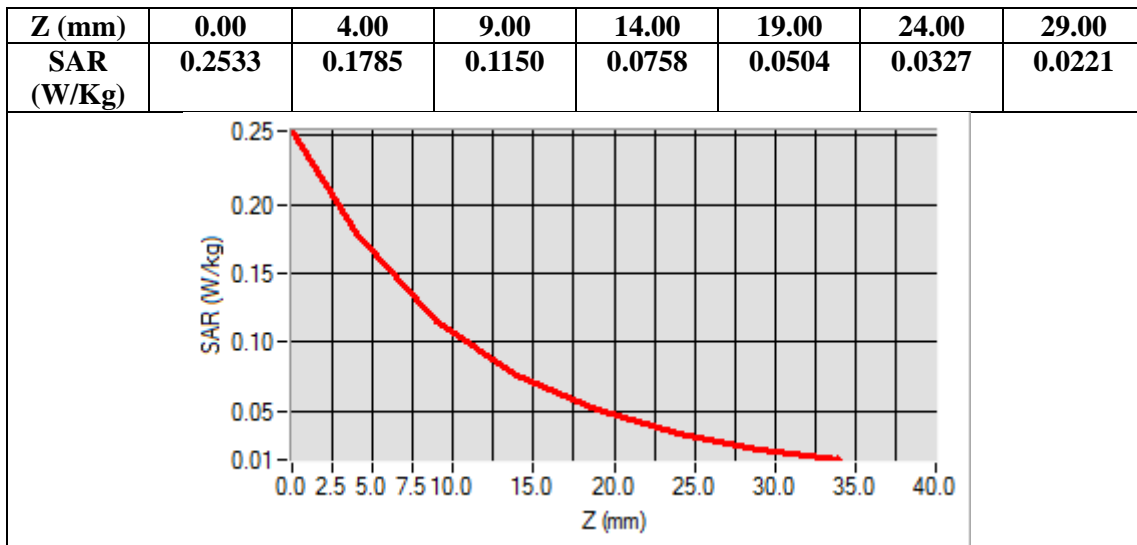

Test Laboratory: AGC Lab
WCDMA Band IV Mid-Body-Towards Grounds (RMC)
DUT: Rugged Mobile Phone; Type: CS24SA

Date: July 02,2017

Communication System: UMTS; Communication System Band: BAND IV UTRA/FDD; Duty Cycle:1: 1; Conv.F=5.06;
Frequency:1732.5 MHz; Medium parameters used: $f = 1750$ MHz; $\zeta = 1.46$ mho/m; $\epsilon_r = 53.87$; $\rho = 1000$ kg/m³;
Phantom section: Flat Section
Ambient temperature (°C): 22.1, Liquid temperature (°C): 21.5

SATIMO Configuration:

- Probe: SSE5; Calibrated: 07/05/2016; Serial No.: SN 14/16 EP307
- Sensor-Surface: 4mm (Mechanical Surface Detection)
- Phantom: SAM twin phantom
- Measurement SW: OpenSAR V4_02_35

Configuration/ WCDMA Band IV Mid-Body-Back/Area Scan: Measurement grid: dx=8mm, dy=8mm

Configuration/ WCDMA Band IV Mid-Body-Back/Zoom Scan: Measurement grid: dx=8mm,dy=8mm, dz=5mm;

Area Scan	sam_direct_droit2_surf8mm.txt
ZoomScan	5x5x7,dx=8mm dy=8mm dz=5mm,Complete
Phantom	Validation plane
Device Position	Body Back
Band	WCDMA Band IV
Channels	Middle
Signal	CDMA (Crest factor: 1.0)

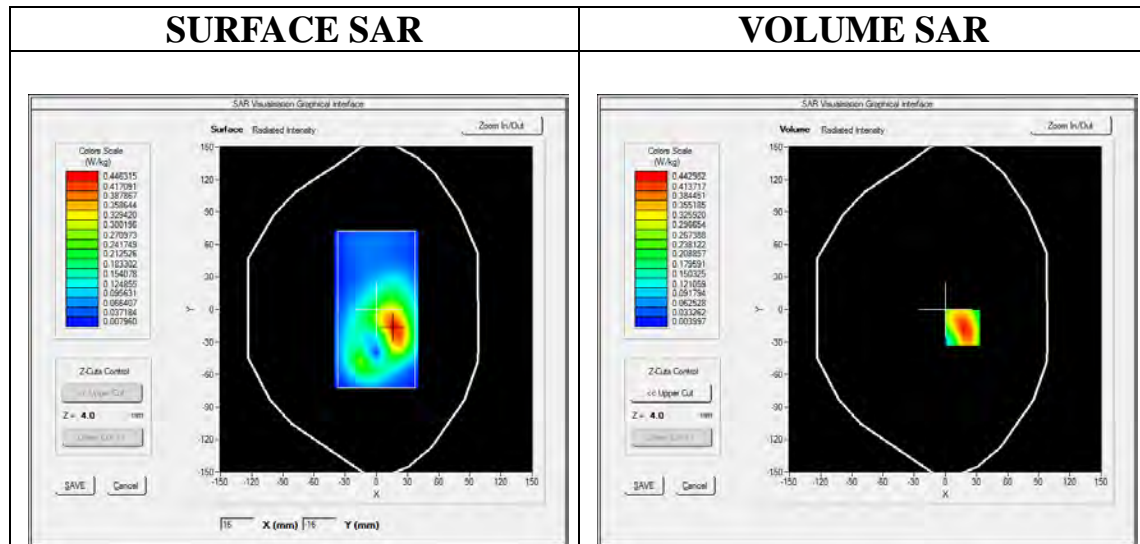

Maximum location: X=17.00, Y=-17.00

SAR Peak: 0.67 W/kg

SAR 10g (W/Kg)	0.236845
SAR 1g (W/Kg)	0.419981

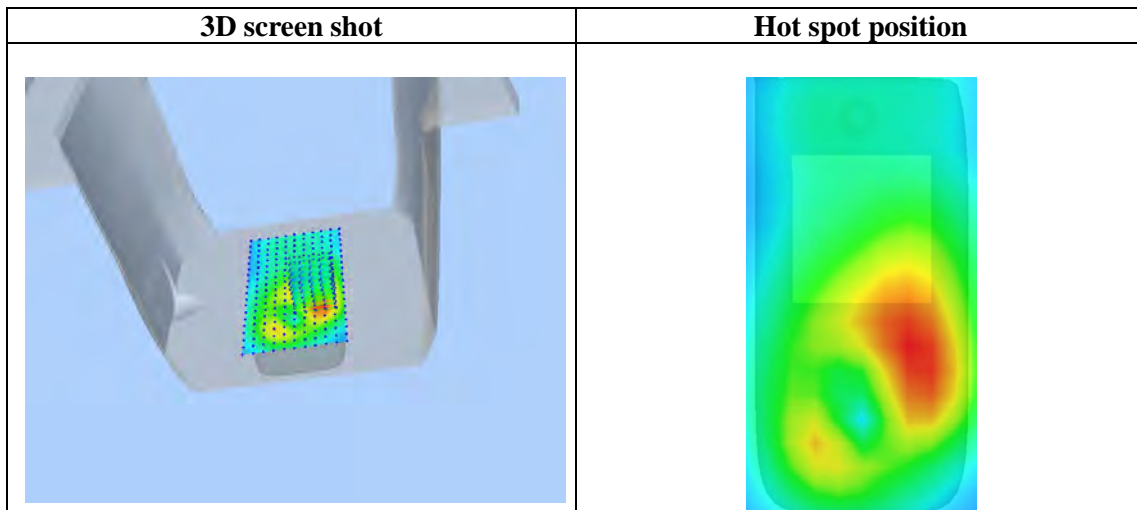
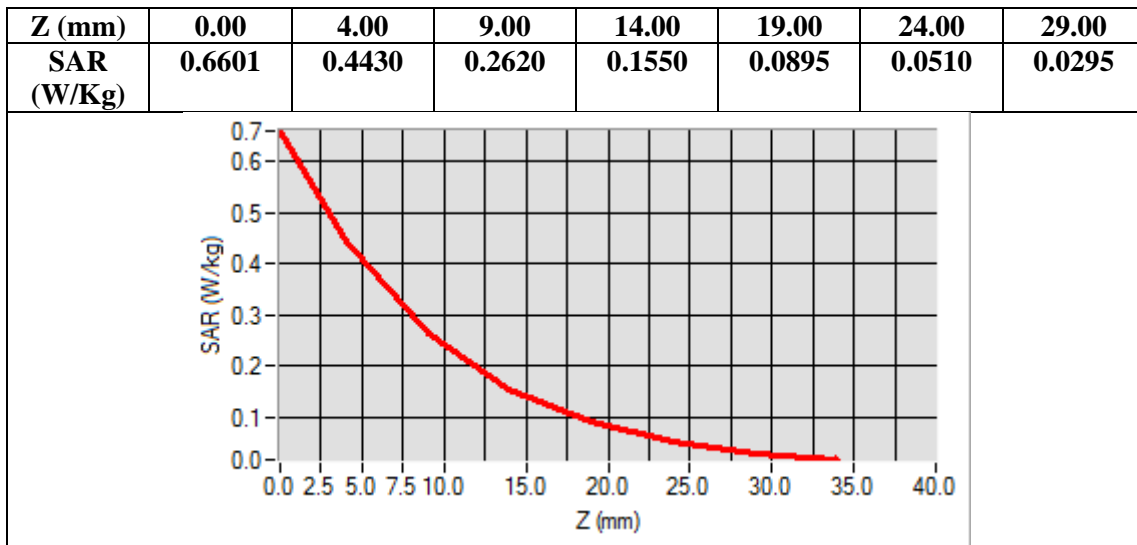

Test Laboratory: AGC Lab

Date: July 02,2017

WCDMA Band V Mid-Touch-Right (RMC)

DUT: Rugged Mobile Phone; Type: CS24SA

Communication System: UMTS; Communication System Band: BAND V UTRA/FDD ; Duty Cycle:1: 1; Conv.F=5.72; Frequency: 836.6 MHz; Medium parameters used: f = 835MHz; $\zeta=0.91$ mho/m; $\epsilon_r=41.23$; $\rho=1000$ kg/m³ ; Phantom section: Right Section
Ambient temperature (°C): 21.9, Liquid temperature (°C): 21.3

SATIMO Configuration:

- Probe: SSE5; Calibrated: 12/05/2016; Serial No.: SN 14/16 EP308
- Sensor-Surface: 4mm (Mechanical Surface Detection)
- Phantom: SAM twin phantom
- Measurement SW: OpenSAR V4_02_32

Configuration/ WCDMA Band V Mid-Touch-Right/Area Scan: Measurement grid: dx=8mm, dy=8mm

Configuration/ WCDMA Band V Mid-Touch-Right/Zoom Scan: Measurement grid: dx=8mm, dy=8mm, dz=5mm

Area Scan	sam_direct_droit2_surf8mm.txt
ZoomScan	5x5x7,dx=8mm dy=8mm dz=5mm,Complete
Phantom	Right head
Device Position	Cheek
Band	WCDMA Band V
Channels	Middle
Signal	CDMA (Crest factor: 1.0)

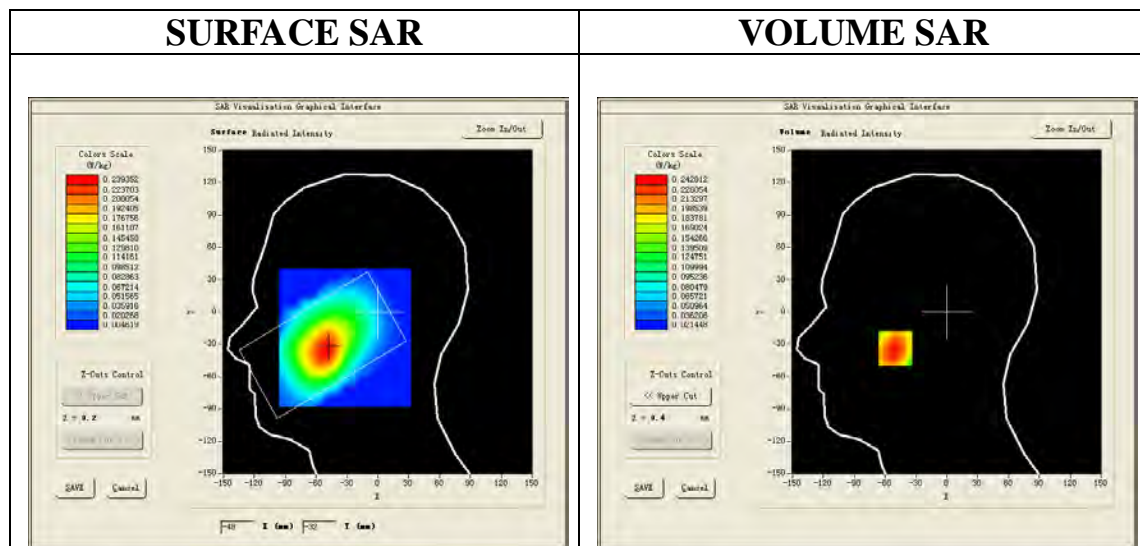

Maximum location: X=-50.00, Y=-34.00

SAR Peak: 0.31 W/kg

SAR 10g (W/Kg)	0.164319
SAR 1g (W/Kg)	0.233581

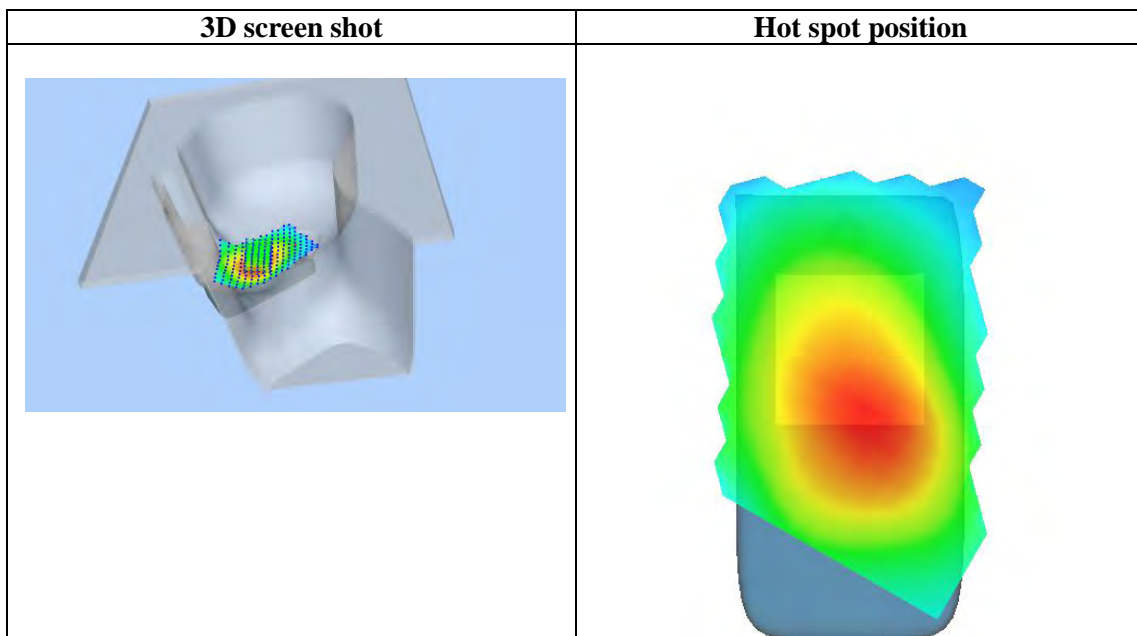
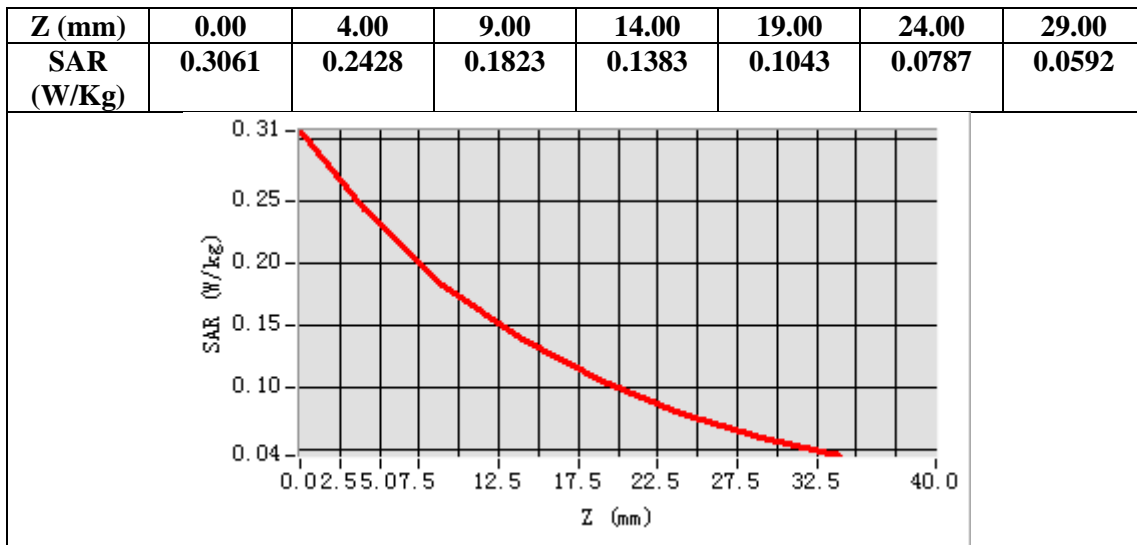

Test Laboratory: AGC Lab

Date: July 02,2017

WCDMA Band V Mid-Body-Towards Grounds (RMC)

DUT: Rugged Mobile Phone; Type: CS24SA

Communication System: UMTS; Communication System Band: BAND V UTRA/FDD; Duty Cycle:1: 1; Conv.F=5.94; Frequency: 836.6 MHz; Medium parameters used: $f = 835$ MHz; $\zeta = 0.97$ mho/m; $\epsilon_r = 55.21$; $\rho = 1000$ kg/m³ ; Phantom section: Flat Section
Ambient temperature (°C): 21.9, Liquid temperature (°C): 21.5

SATIMO Configuration:

- Probe: SSE5; Calibrated: 12/05/2016; Serial No.: SN 14/16 EP308
- Sensor-Surface: 4mm (Mechanical Surface Detection)
- Phantom: SAM twin phantom
- Measurement SW: OpenSAR V4_02_32

Configuration/ WCDMA Band V Mid -Body-Back/Area Scan: Measurement grid: dx=8mm, dy=8mm

Configuration/ WCDMA Band V Mid -Body-Back/Zoom Scan: Measurement grid: dx=8mm,dy=8mm, dz=5mm;

Area Scan	sam_direct_droit2_surf8mm.txt
ZoomScan	5x5x7,dx=8mm dy=8mm dz=5mm,Complete
Phantom	Validation plane
Device Position	Body Back
Band	WCDMA Band V
Channels	Middle
Signal	CDMA (Crest factor: 1.0)

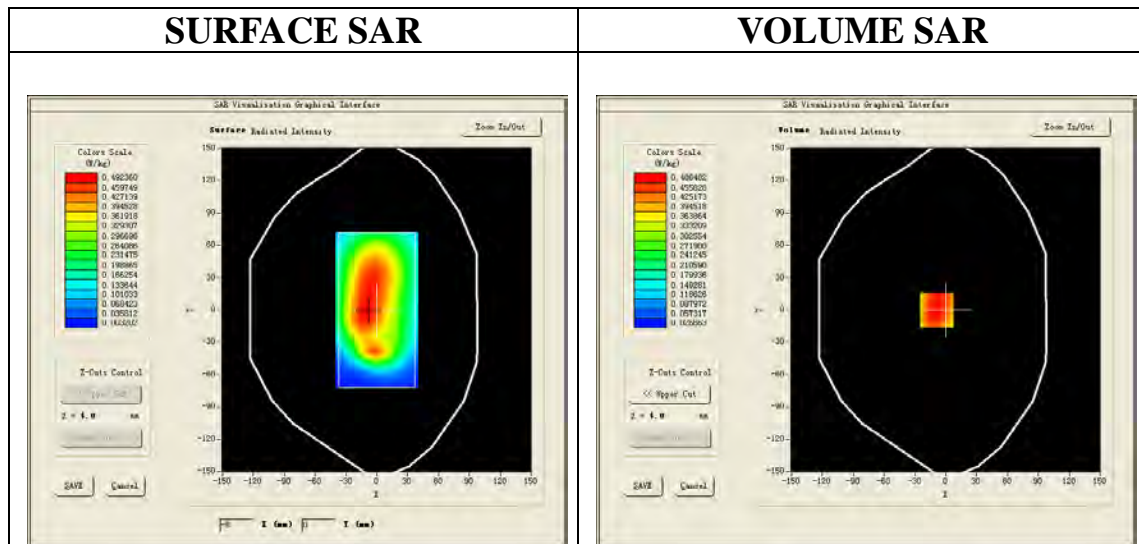

Maximum location: X=-9.00, Y=0.00

SAR Peak: 0.64 W/kg

SAR 10g (W/Kg)	0.328227
SAR 1g (W/Kg)	0.473007

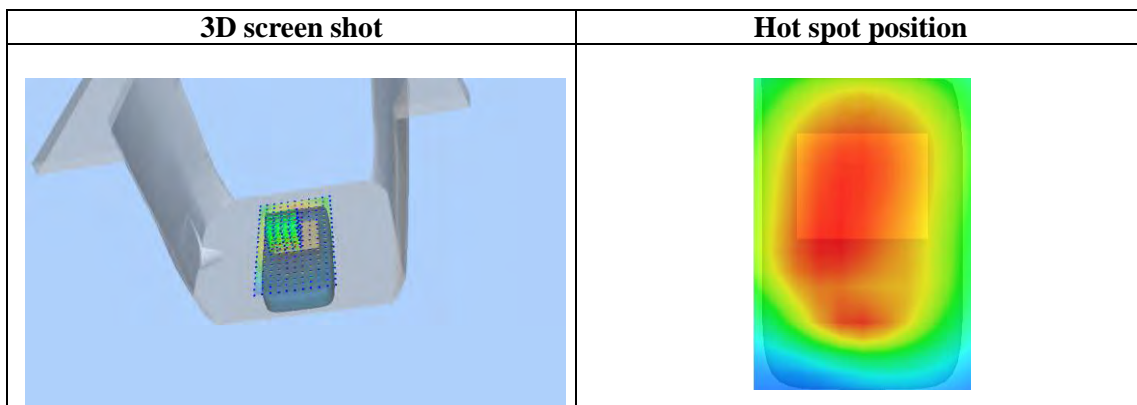
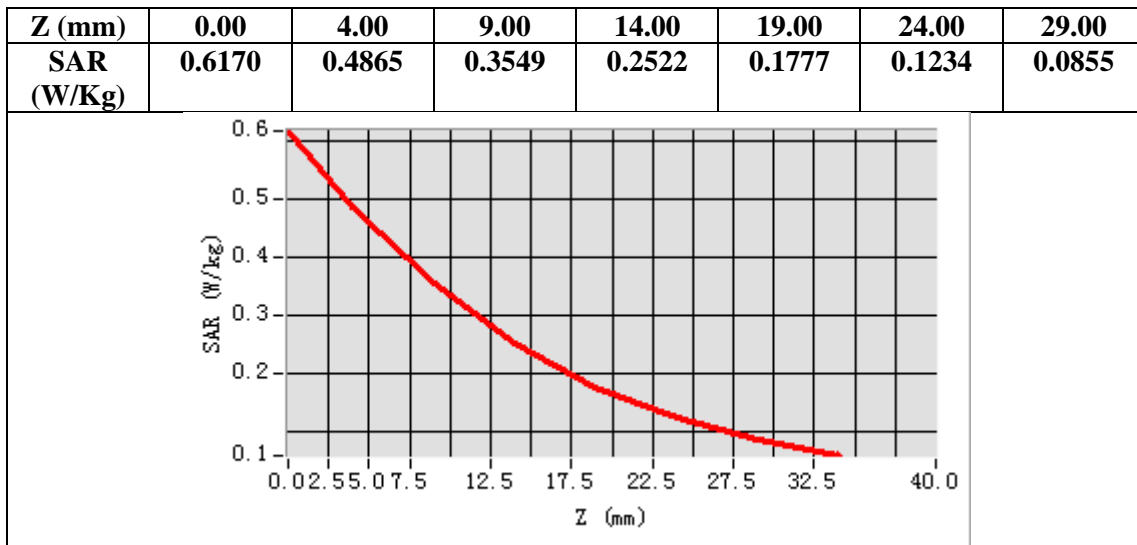

Test Laboratory: AGC Lab
LTE Band II High-Touch-Left (1 RB#50)
DUT: Rugged Mobile Phone; Type: CS24SA

Date: June 28, 2017

Communication System: LTE; Communication System Band: LTE Band II; Duty Cycle:1:1; Conv.F=5.14;
Frequency: 1900MHz; Medium parameters used: $f = 1900$ MHz; $\zeta = 1.38$ mho/m; $\epsilon_r = 39.51$; $\rho = 1000$ kg/m³ ;
Phantom section: Left Section
Ambient temperature (°C): 22.1, Liquid temperature (°C): 21.3

SATIMO Configuration:

- Probe: SSE5; Calibrated: 07/05/2016; Serial No.: SN 14/16 EP307
- Sensor-Surface: 4mm (Mechanical Surface Detection)
- Phantom: SAM twin phantom
- Measurement SW: OpenSAR V4_02_35

Configuration/ LTE Band II High - Touch-Left /Area Scan: Measurement grid: dx=8mm, dy=8mm

Configuration/ LTE Band II High - Touch-Left /Zoom Scan: Measurement grid: dx=8mm,dy=8mm, dz=5mm;

Area Scan	sam_direct_droit2_surf8mm.txt
Zoom Scan	5x5x7,dx=8mm dy=8mm dz=5mm
Phantom	Left head
Device Position	Cheek
Band	LTE Band II
Channels	High
Signal	OFDM (Crest factor: 1.0)

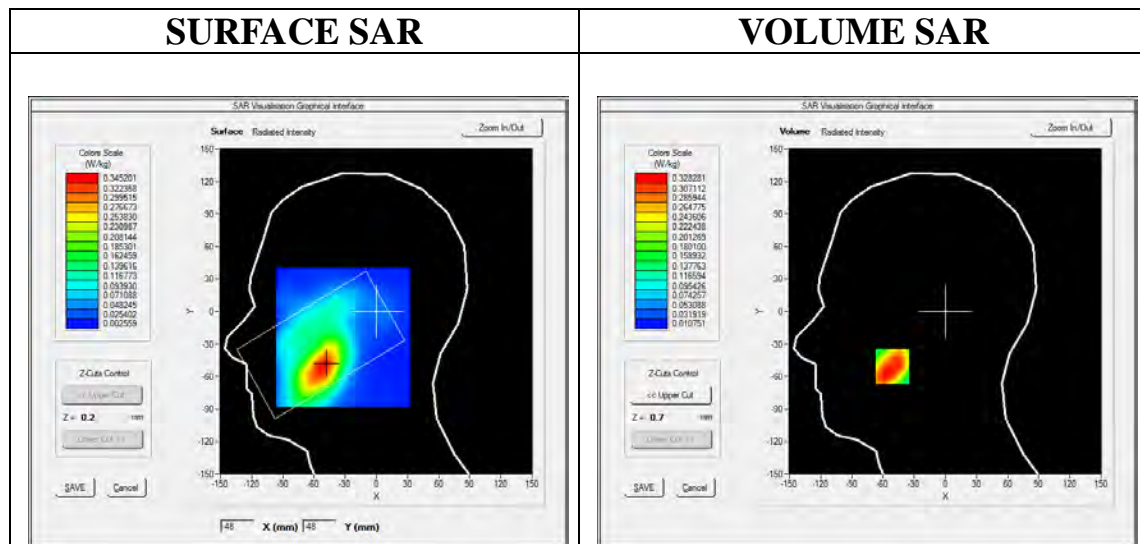

Maximum location: X=-51.00, Y=-51.00

SAR Peak: 0.50 W/kg

SAR 10g (W/Kg)	0.200915
SAR 1g (W/Kg)	0.318260

Z (mm)	0.00	4.00	9.00	14.00	19.00	24.00	29.00
SAR (W/Kg)	0.4725	0.3283	0.2126	0.1481	0.1004	0.0718	0.0454

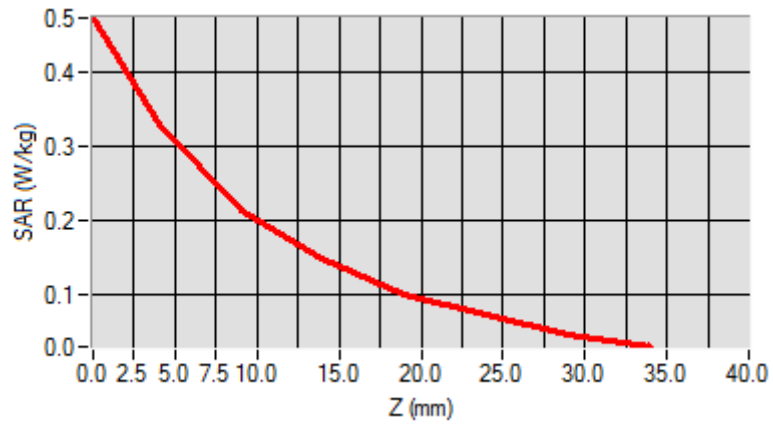

3D screen shot

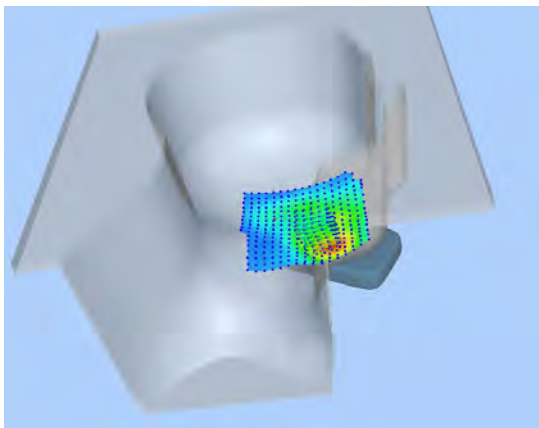

Hot spot position

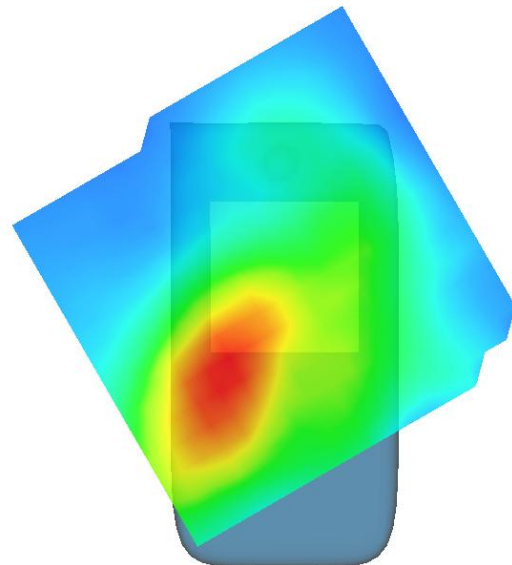

Test Laboratory: AGC Lab
LTE Band II High - Body-Back (1 RB#50)
DUT: Rugged Mobile Phone; Type: CS24SA

Date: June 28, 2017

Communication System: LTE; Communication System Band: LTE Band II; Duty Cycle:1:1; Conv.F=5.34;
Frequency:1900MHz; Medium parameters used: $f = 1900 \text{ MHz}$; $\zeta = 1.51 \text{ mho/m}$; $\epsilon_r = 53.58$; $\rho = 1000 \text{ kg/m}^3$;
Phantom section: Flat Section
Ambient temperature ($^{\circ}\text{C}$): 22.1, Liquid temperature ($^{\circ}\text{C}$): 21.5

SATIMO Configuration:

- Probe: SSE5; Calibrated: 07/05/2016; Serial No.: SN 14/16 EP307
- Sensor-Surface: 4mm (Mechanical Surface Detection)
- Phantom: SAM twin phantom
- Measurement SW: OpenSAR V4_02_35

Configuration/ LTE Band II High - Body-Back /Area Scan: Measurement grid: dx=8mm, dy=8mm
Configuration/ LTE Band II High - E Body-Back /Zoom Scan: Measurement grid: dx=8mm,dy=8mm, dz=5m;

Area Scan	sam_direct_droit2_surf8mm.txt
Zoom Scan	5x5x7,dx=8mm dy=8mm dz=5mm
Phantom	Validation plane
Device Position	Body-Back
Band	LTE Band II
Channels	High
Signal	OFDM (Crest factor: 1.0)

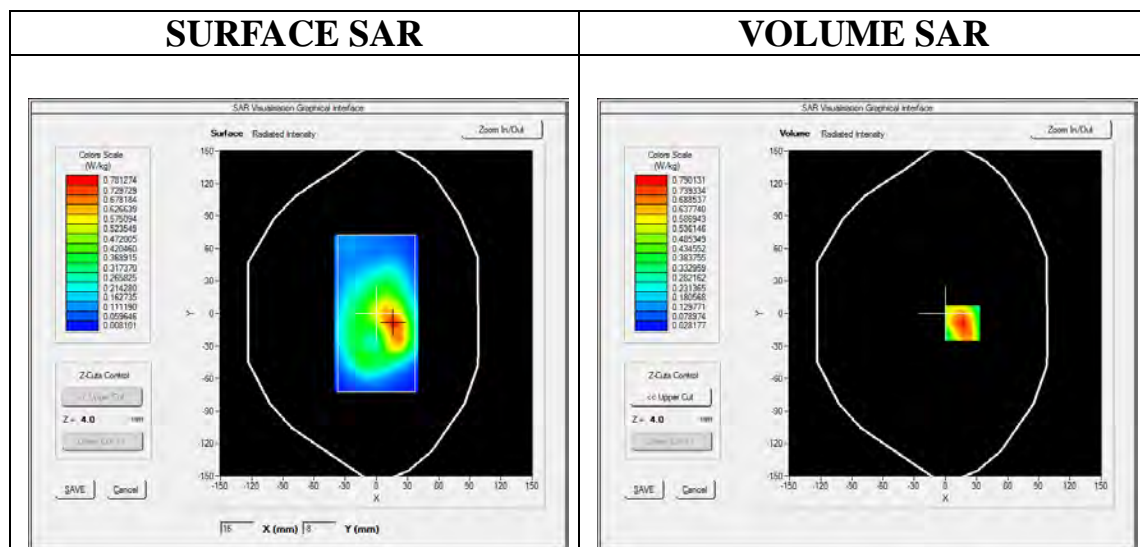

Maximum location: X=17.00, Y=-9.00

SAR Peak: 1.17 W/kg

SAR 10g (W/Kg)	0.435966
SAR 1g (W/Kg)	0.749357

Z (mm)	0.00	4.00	9.00	14.00	19.00	24.00	29.00
SAR (W/Kg)	1.1628	0.7901	0.4793	0.3206	0.1911	0.1181	0.0737

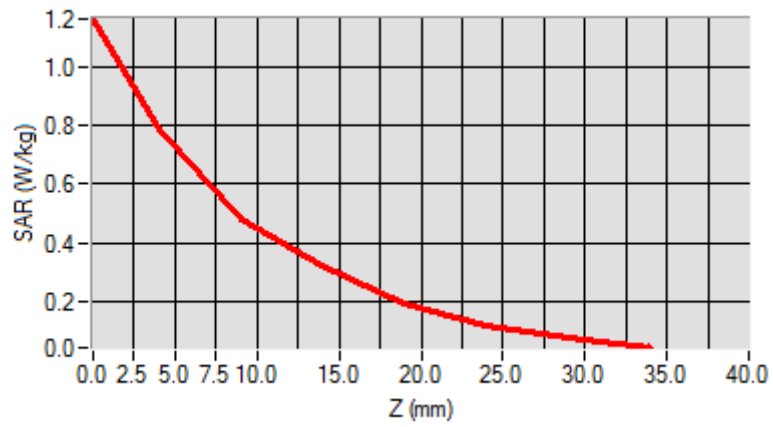

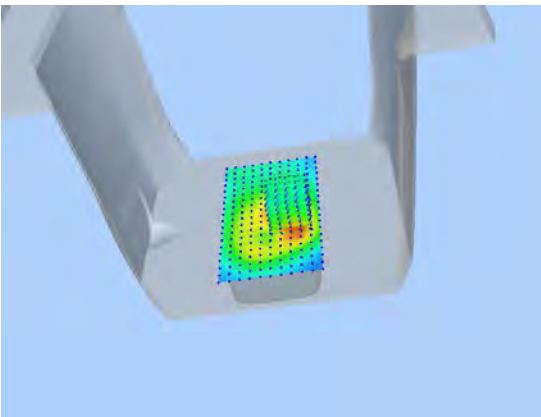
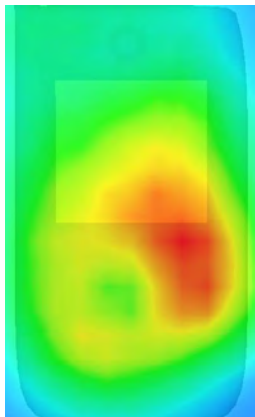
3D screen shot	Hot spot position
	

Test Laboratory: AGC Lab

Date: July 02,2017

LTE Band IV Mid-Touch-Left (1 RB#0)

DUT: Rugged Mobile Phone; Type: CS24SA

Communication System: LTE; Communication System Band: LTE Band IV; Duty Cycle:1:1; Conv.F=4.92; Frequency:1732.5 MHz; Medium parameters used: $f = 1750$ MHz; $\zeta = 1.35$ mho/m; $\epsilon_r = 41.03$; $\rho = 1000$ kg/m³ ; Phantom section: Left Section
Ambient temperature (°C): 22.1, Liquid temperature (°C): 21.3

SATIMO Configuration:

- Probe: SSE5; Calibrated: 07/05/2016; Serial No.: SN 14/16 EP307
- Sensor-Surface: 4mm (Mechanical Surface Detection)
- Phantom: SAM twin phantom
- Measurement SW: OpenSAR V4_02_35

Configuration/ LTE Band IV Mid- Touch-Left /Area Scan: Measurement grid: dx=8mm, dy=8mm

Configuration/ LTE Band IV Mid- Touch-Left /Zoom Scan: Measurement grid: dx=8mm,dy=8mm, dz=5mm;

Area Scan	sam_direct_droit2_surf8mm.txt
Zoom Scan	5x5x7,dx=8mm dy=8mm dz=5mm
Phantom	Left head
Device Position	Cheek
Band	LTE Band IV
Channels	Middle
Signal	OFDM (Crest factor: 1.0)

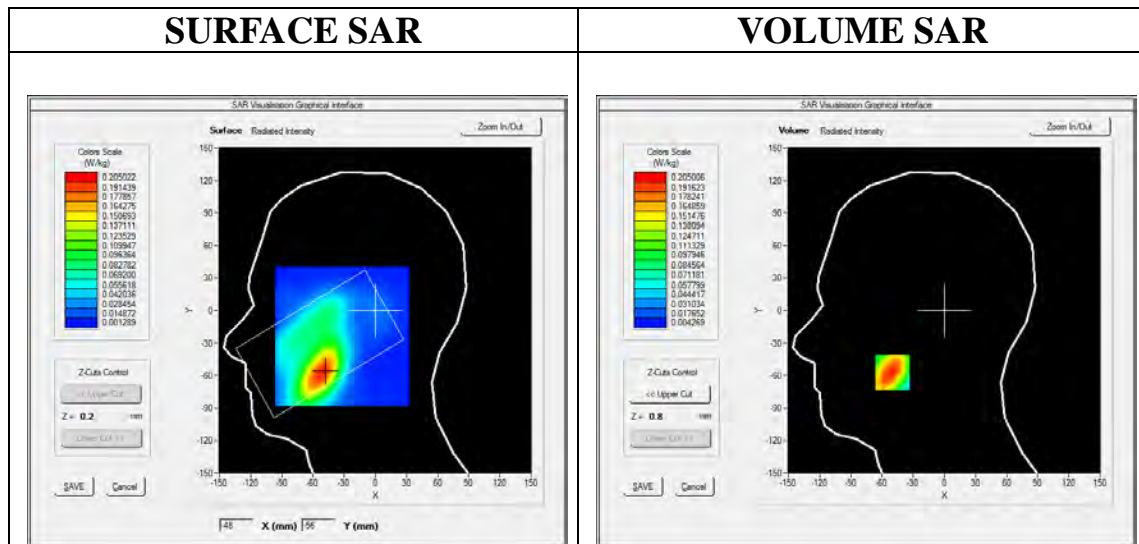

Maximum location: X=-50.00, Y=-57.00

SAR Peak: 0.29 W/kg

SAR 10g (W/Kg)	0.118928
SAR 1g (W/Kg)	0.195832

Z (mm)	0.00	4.00	9.00	14.00	19.00	24.00	29.00
SAR (W/Kg)	0.2880	0.2050	0.1355	0.0933	0.0641	0.0423	0.0286

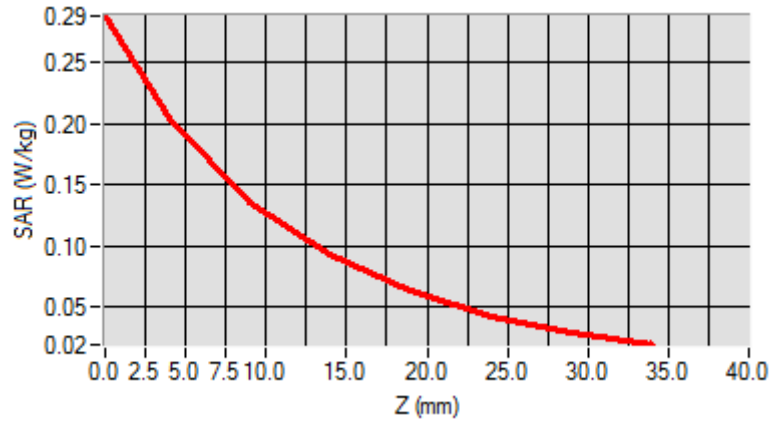

3D screen shot

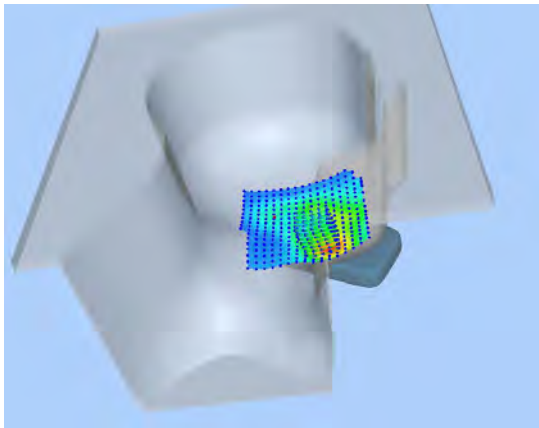

Hot spot position

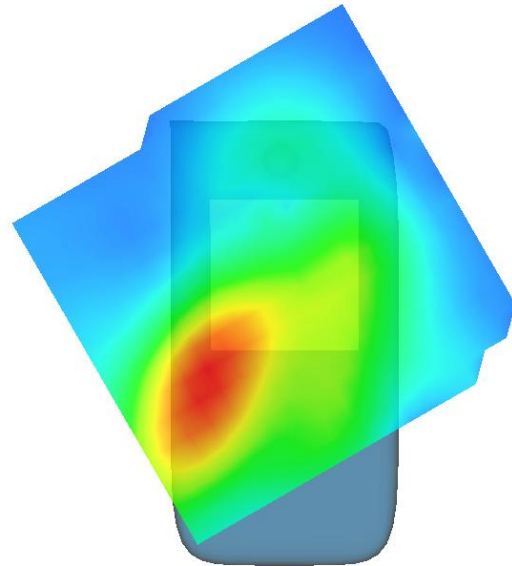

Test Laboratory: AGC Lab

Date: July 02,2017

LTE Band IV Mid-Body-Back (1 RB#0)

DUT: Rugged Mobile Phone; Type: CS24SA

Communication System: LTE; Communication System Band: LTE Band IV; Duty Cycle:1:1; Conv.F=5.06;
Frequency:1732.5 MHz; Medium parameters used: $f = 1750$ MHz; $\zeta = 1.46$ mho/m; $\epsilon_r = 53.87$; $\rho = 1000$ kg/m³ ;
Phantom section: Flat Section
Ambient temperature (°C): 22.1, Liquid temperature (°C): 21.5

SATIMO Configuration:

- Probe: SSE5; Calibrated: 07/05/2016; Serial No.: SN 14/16 EP307
- Sensor-Surface: 4mm (Mechanical Surface Detection)
- Phantom: SAM twin phantom
- Measurement SW: OpenSAR V4_02_35

Configuration/ LTE Band IV Mid-Body-back/Area Scan: Measurement grid: dx=8mm, dy=8mm

Configuration/ LTE Band IV Mid-Body-back/Zoom Scan: Measurement grid: dx=8mm,dy=8mm, dz=5mm;

Area Scan	sam_direct_droit2_surf8mm.txt
Zoom Scan	5x5x7,dx=8mm dy=8mm dz=5mm
Phantom	Validation plane
Device Position	Body Back
Band	LTE Band IV
Channels	Middle
Signal	OFDM (Crest factor: 1.0)

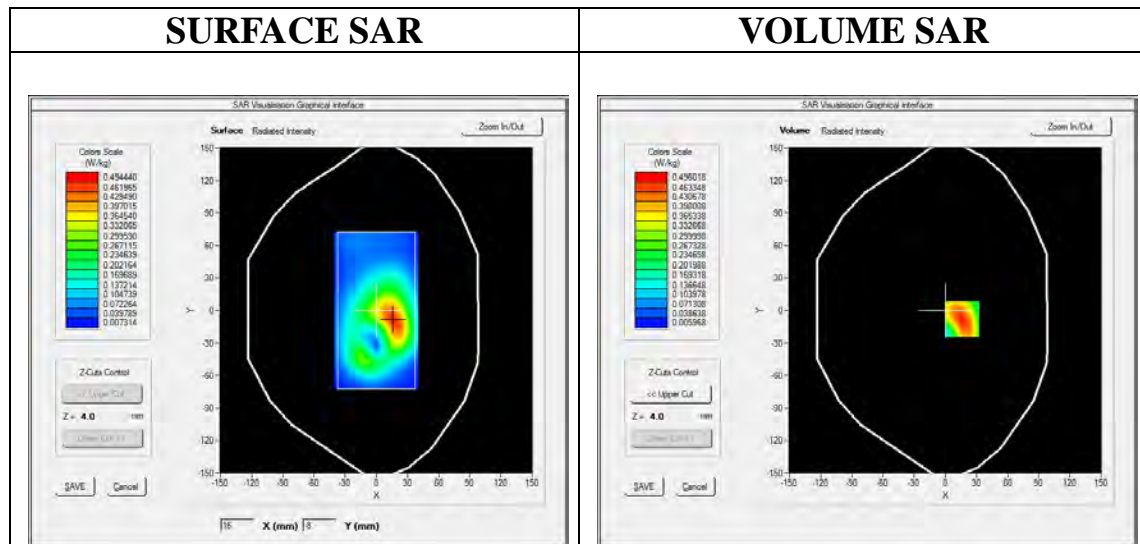

Maximum location: X=16.00, Y=-8.00

SAR Peak: 0.73 W/kg

SAR 10g (W/Kg)	0.270273
SAR 1g (W/Kg)	0.468728

Z (mm)	0.00	4.00	9.00	14.00	19.00	24.00	29.00
SAR (W/Kg)	0.7227	0.4960	0.3028	0.1834	0.1090	0.0642	0.0379

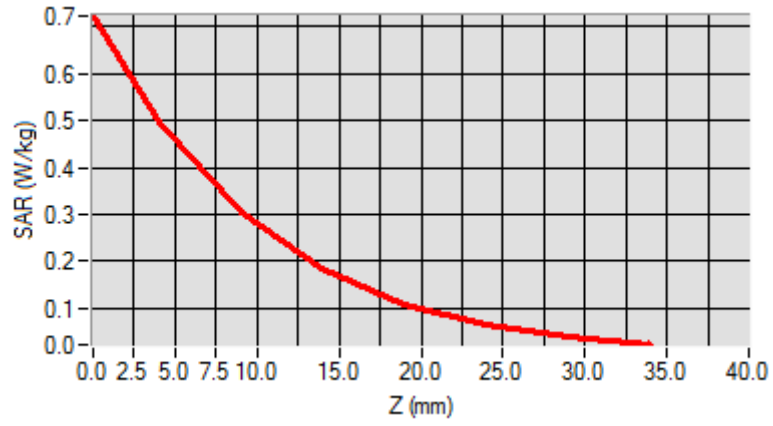

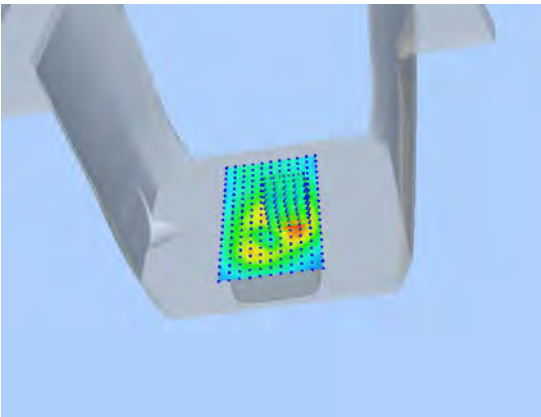
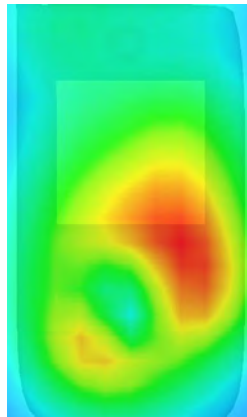
3D screen shot	Hot spot position
	

Test Laboratory: AGC Lab
LTE Band V Mid -Touch-Right (1 RB#0)
DUT: Rugged Mobile Phone; Type: CS24SA

Date: July 02,2017

Communication System: LTE; Communication System Band: LTE Band V; Duty Cycle:1:1; Conv.F=5.72
Frequency: 836.5 MHz; Medium parameters used: $f = 835$ MHz; $\zeta = 0.91$ mho/m; $\epsilon_r = 41.23$; $\rho = 1000$ kg/m³ ;
Phantom section: Right Section
Ambient temperature (°C): 21.9, Liquid temperature (°C): 21.3

SATIMO Configuration:

- Probe: SSE5; Calibrated: 12/05/2016; Serial No.: SN 14/16 EP308
- Sensor-Surface: 4mm (Mechanical Surface Detection)
- Phantom: SAM twin phantom
- Measurement SW: OpenSAR V4_02_32

Configuration/ LTE Band V Mid - Touch-Right /Area Scan: Measurement grid: dx=8mm, dy=8mm
Configuration/ LTE Band V Mid - Touch-Right /Zoom Scan: Measurement grid: dx=8mm,dy=8mm, dz=5mm;

Area Scan	sam_direct_droit2_surf8mm.txt
Zoom Scan	5x5x7,dx=8mm dy=8mm dz=5mm
Phantom	Right head
Device Position	Cheek
Band	LTE Band V
Channels	Middle
Signal	OFDM (Crest factor: 1.0)

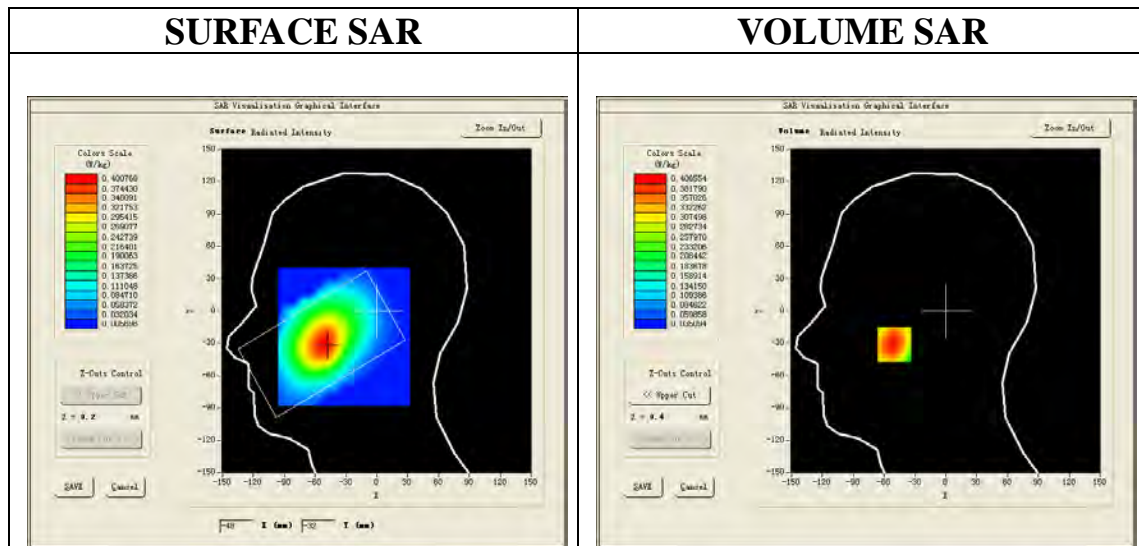

Maximum location: X=-50.00, Y=-31.00
SAR Peak: 0.52 W/kg

SAR 10g (W/Kg)	0.276571
SAR 1g (W/Kg)	0.391796

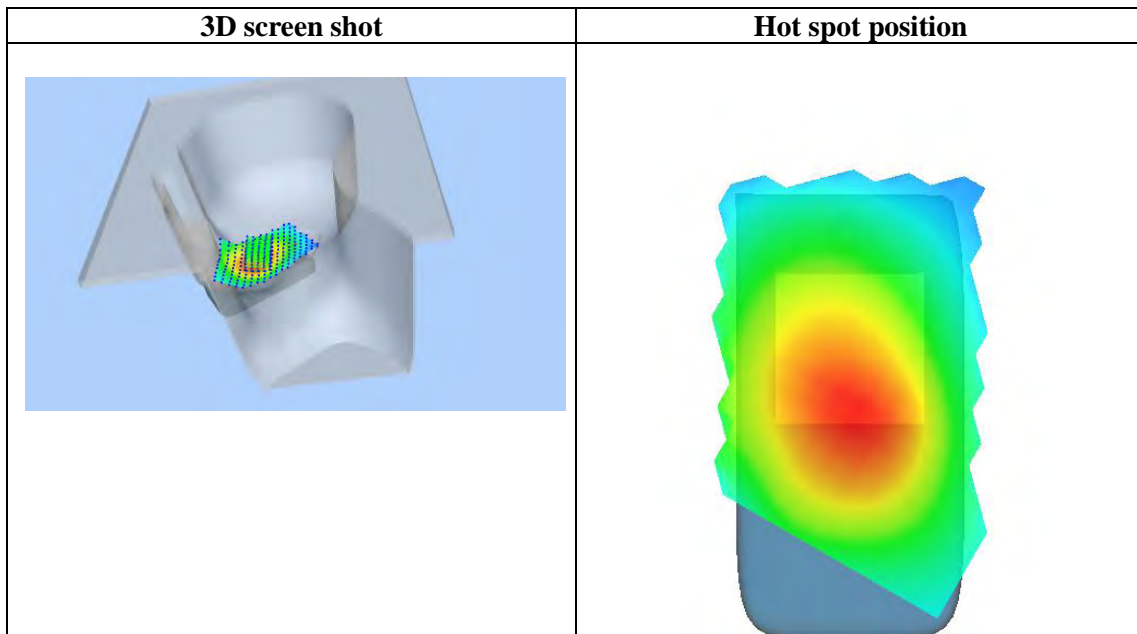
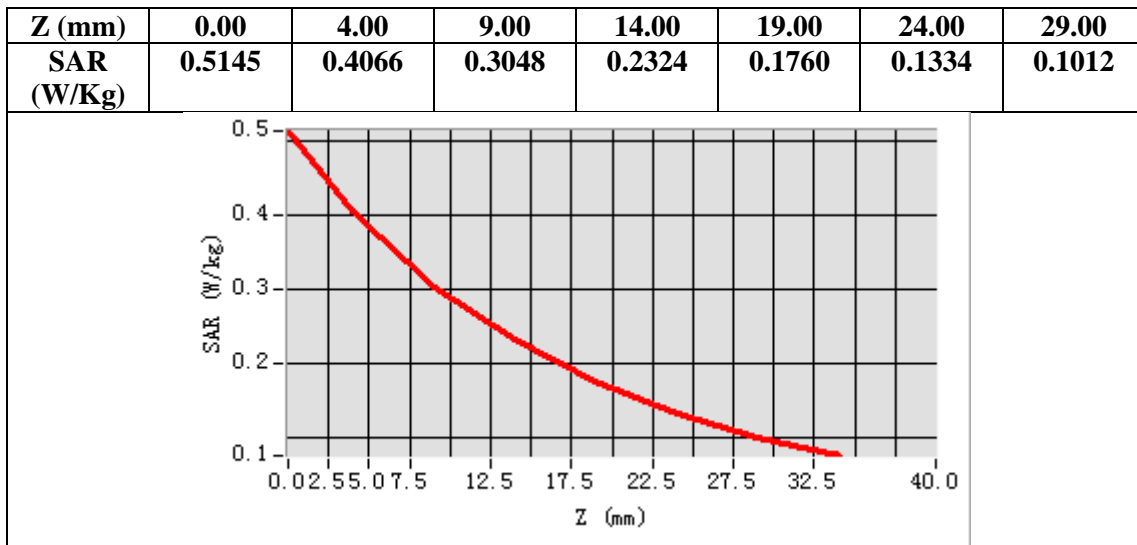

Test Laboratory: AGC Lab
LTE Band V Mid -Body- Back (1 RB#0)
DUT: Rugged Mobile Phone; Type: CS24SA

Date: July 02,2017

Communication System: LTE; Communication System Band: LTE Band V; Duty Cycle:1:1; Conv.F=5.94
Frequency: 836.5MHz; Medium parameters used: $f = 835 \text{ MHz}$; $\zeta = 0.97 \text{ mho/m}$; $\epsilon_r = 55.21$; $\rho = 1000 \text{ kg/m}^3$;
Phantom section: Flat Section
Ambient temperature ($^{\circ}\text{C}$): 21.9, Liquid temperature ($^{\circ}\text{C}$): 21.5

SATIMO Configuration:

- Probe: SSE5; Calibrated: 12/05/2016; Serial No.: SN 14/16 EP308
- Sensor-Surface: 4mm (Mechanical Surface Detection)
- Phantom: SAM twin phantom
- Measurement SW: OpenSAR V4_02_32

Configuration/ LTE Band V Mid -Body- Back /Area Scan: Measurement grid: dx=8mm, dy=8mm
Configuration/ LTE Band V Mid -Body- Back /Zoom Scan: Measurement grid: dx=8mm,dy=8mm, dz=5mm;

Area Scan	sam_direct_droit2_surf8mm.txt
Zoom Scan	5x5x7,dx=8mm dy=8mm dz=5mm
Phantom	Validation plane
Device Position	Body Back
Band	LTE Band V
Channels	Middle
Signal	OFDM (Crest factor: 1.0)

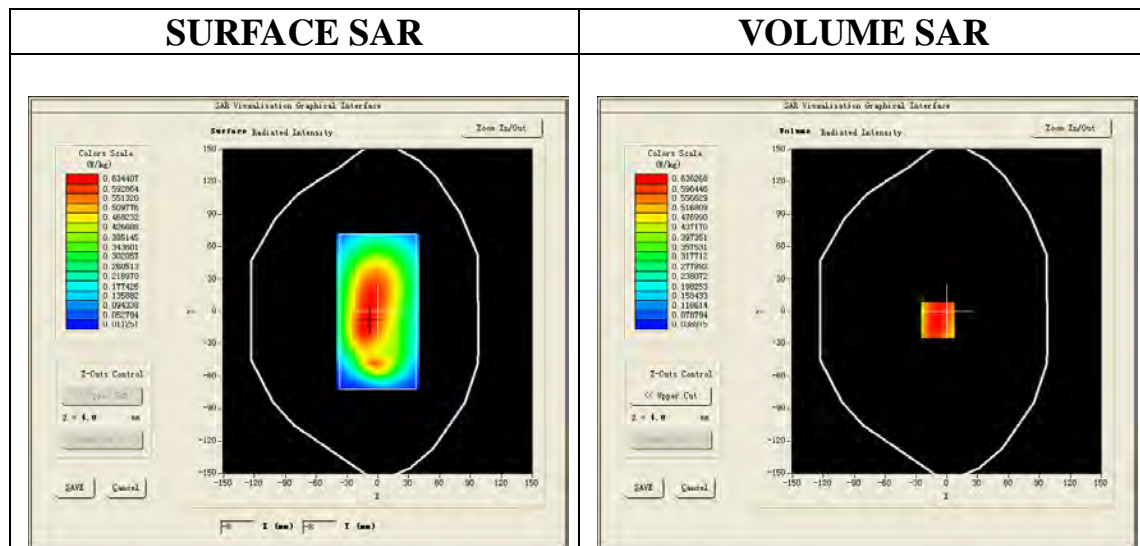

Maximum location: X=-9.00, Y=-8.00
SAR Peak: 0.83 W/kg

SAR 10g (W/Kg)	0.437560
SAR 1g (W/Kg)	0.620015

Z (mm)	0.00	4.00	9.00	14.00	19.00	24.00	29.00
SAR (W/Kg)	0.7967	0.6363	0.4734	0.3466	0.2500	0.1782	0.1261

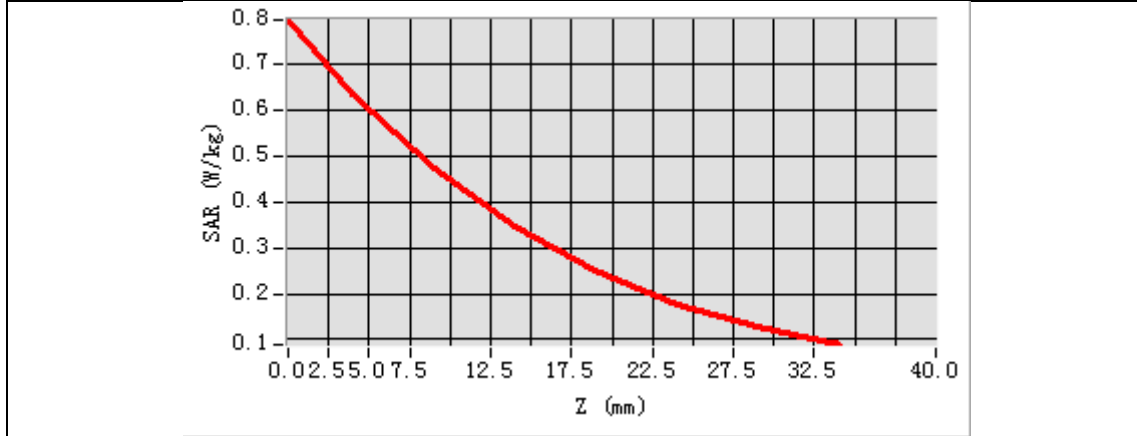

3D screen shot	Hot spot position
<p>A 3D perspective view of a grey, L-shaped device. A rectangular area on the horizontal part of the device is highlighted with a color-coded SAR distribution, showing a hot spot in the center.</p>	<p>A 2D heatmap showing the SAR distribution on the device's surface. The color scale ranges from blue (low SAR) to red (high SAR), with the highest intensity (red) concentrated in the central rectangular area.</p>

Test Laboratory: AGC Lab
LTE Band 7 Mid-Touch-Left (1RB#0)
DUT: Rugged Mobile Phone; Type: CS24SA

Date: July 03,2017

Communication System: LTE; Communication System Band: LTE Band 7; Duty Cycle:1:1; Conv.F=5.07
Frequency: 2535MHz; Medium parameters used: $f = 2600$ MHz; $\zeta = 1.90$ mho/m; $\epsilon_r = 38.95$; $\rho = 1000$ kg/m³ ;
Phantom section: Left Section
Ambient temperature (°C): 21.7, Liquid temperature (°C): 21.1

SATIMO Configuration:

- Probe: SSE5; Calibrated: 12/05/2016; Serial No.: SN 14/16 EP308
- Sensor-Surface: 4mm (Mechanical Surface Detection)
- Phantom: SAM twin phantom
- Measurement SW: OpenSAR V4_02_32

Configuration/ LTE BAND 7 Mid-Touch-Left/Area Scan: Measurement grid: dx=8mm, y=8mm
Configuration/ LTE BAND 7 Mid-Touch-Left/Zoom Scan: Measurement grid: dx=8mm, dy=8mm, dz=5mm

Area Scan	sam_direct_droit2_surf8mm.txt
ZoomScan	5x5x7,dx=8mm dy=8mm dz=5mm
Phantom	Left head
Device Position	Cheek
Band	LTE BAND 7
Channels	Middle
Signal	OFDM (Crest factor: 1.0)

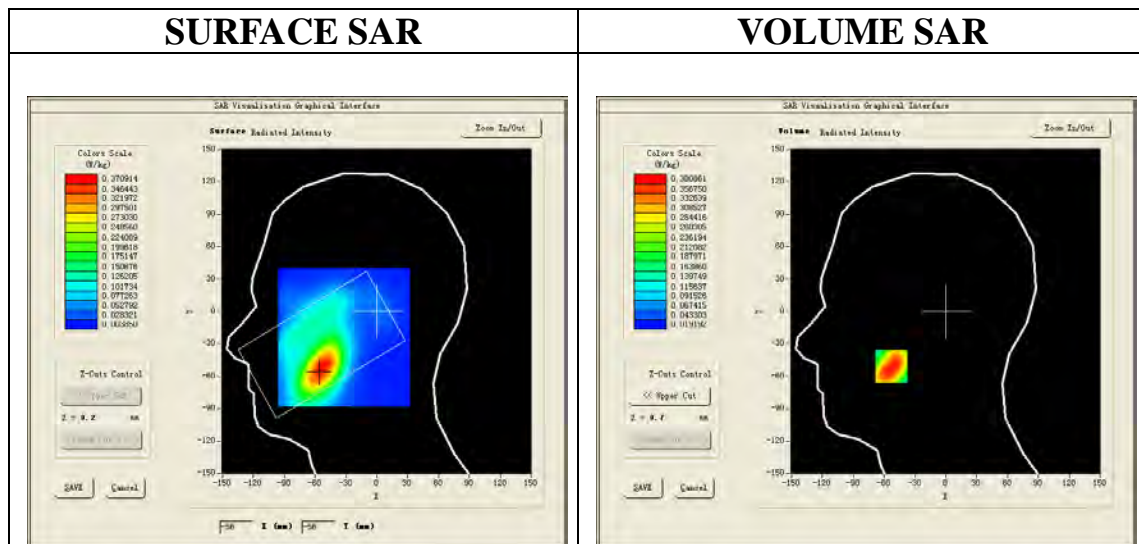

Maximum location: X=-53.00, Y=-51.00

SAR Peak: 0.52 W/kg

SAR 10g (W/Kg)	0.223480
SAR 1g (W/Kg)	0.352190

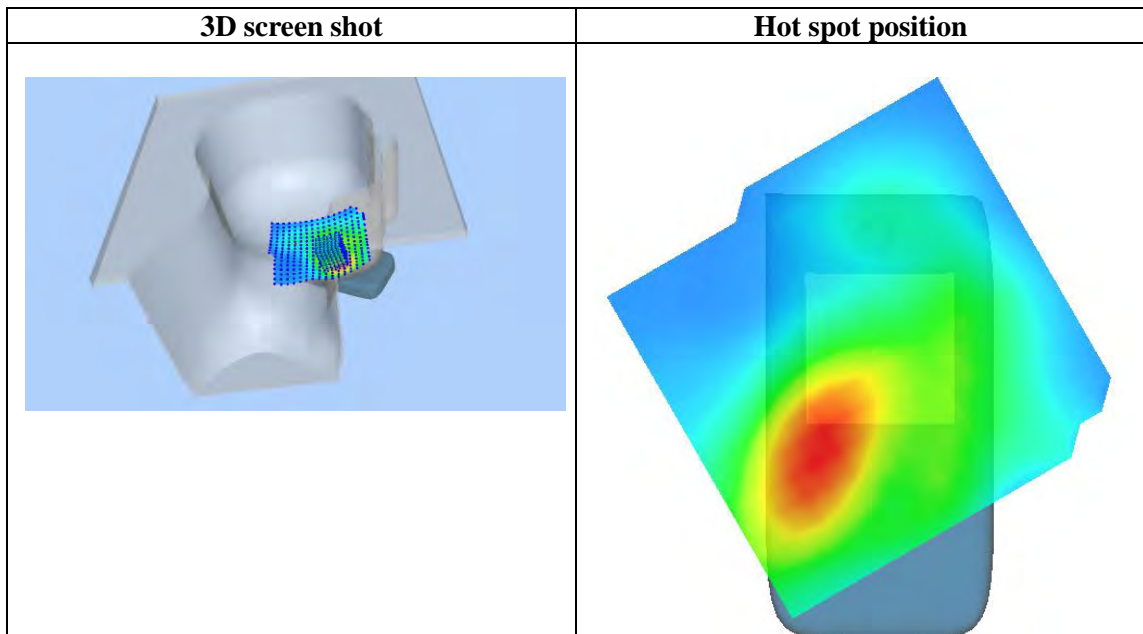
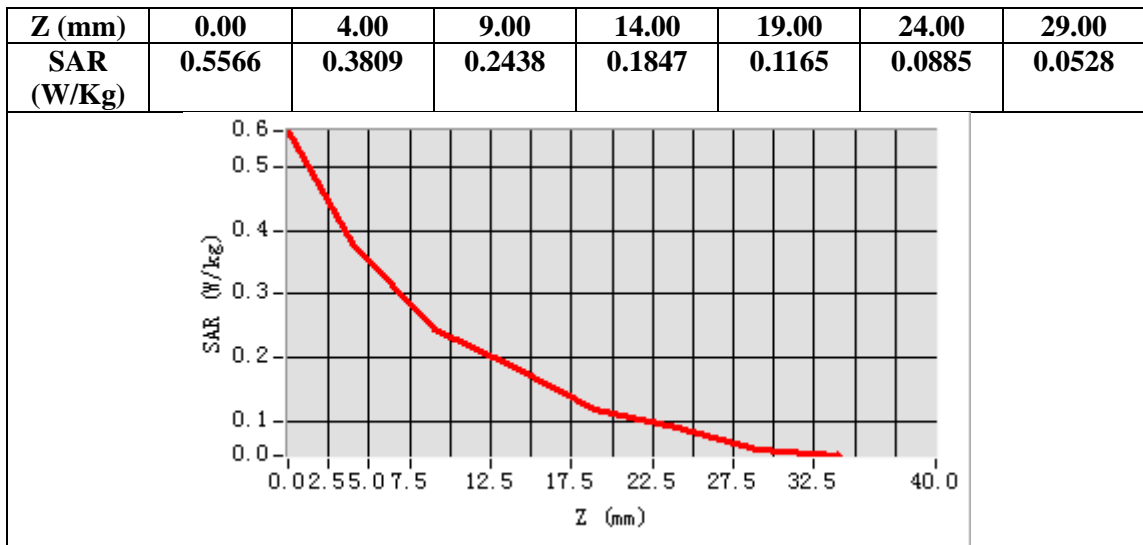

Test Laboratory: AGC Lab
LTE Band 7 Mid-Body-Back (1RB#0)
DUT: Rugged Mobile Phone; Type: CS24SA

Date: July 03,2017

Communication System: LTE; Communication System Band: LTE Band 7; Duty Cycle:1:1; Conv.F=5.19
Frequency: 2535MHz; Medium parameters used: $f = 2600$ MHz; $\zeta = 2.12$ mho/m; $\epsilon_r = 53.57$; $\rho = 1000$ kg/m³ ;
Phantom section: Flat Section
Ambient temperature (°C): 21.7, Liquid temperature (°C): 21.3

SATIMO Configuration:

- Probe: SSE5; Calibrated: 12/05/2016; Serial No.: SN 14/16 EP308
- Sensor-Surface: 4mm (Mechanical Surface Detection)
- Phantom: SAM twin phantom
- Measurement SW: OpenSAR V4_02_32

Configuration/ LTE BAND 7 Mid-Body-Back /Area Scan: Measurement grid: dx=10mm, y=10mm
Configuration/ LTE BAND 7 Mid-Body-Back /Zoom Scan: Measurement grid: dx=8mm, dy=8mm, dz=5mm

Area Scan	sam_direct_droit2_surf8mm.txt
ZoomScan	5x5x7,dx=8mm dy=8mm dz=5mm
Phantom	Validation plane
Device Position	Body Back
Band	LTE BAND 7
Channels	Middle
Signal	OFDM (Crest factor: 1.0)

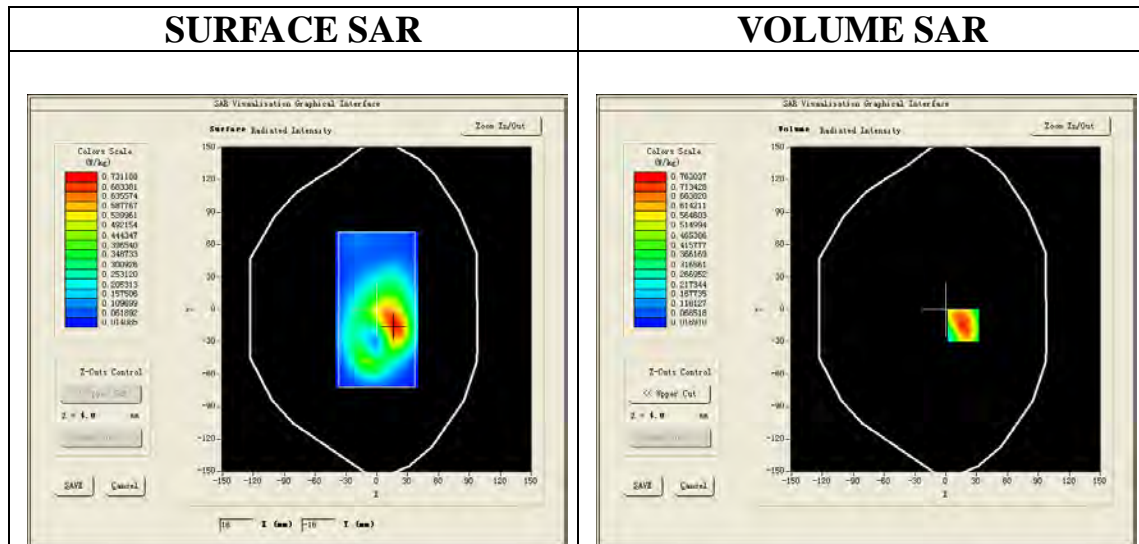

Maximum location: X=17.00, Y=-15.00

SAR Peak: 1.14 W/kg

SAR 10g (W/Kg)	0.406187
SAR 1g (W/Kg)	0.696278

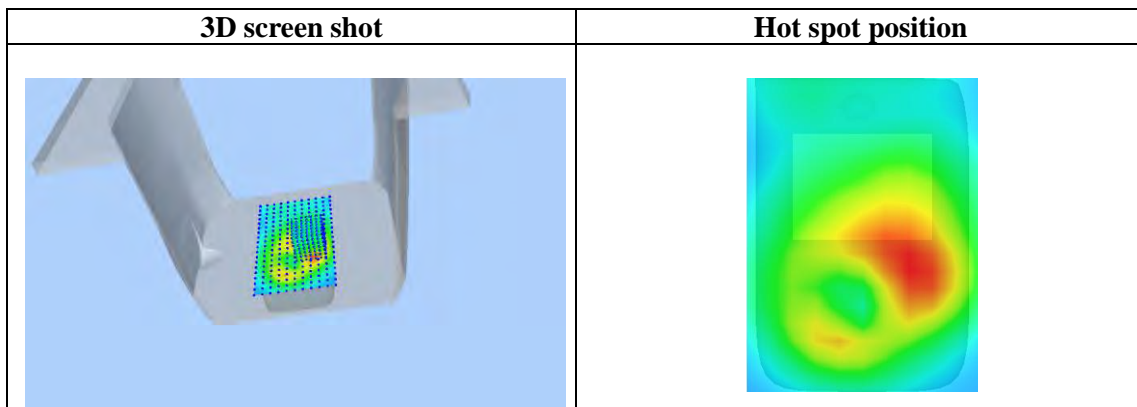
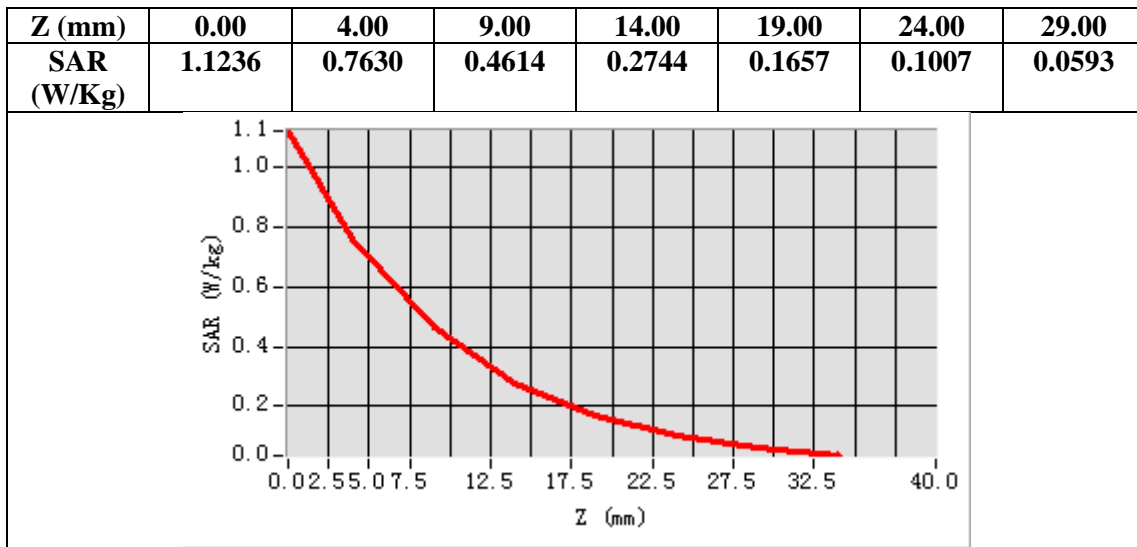

Test Laboratory: AGC Lab
LTE Band XVII Mid-Touch-Right (1 RB#0)
DUT: Rugged Mobile Phone; Type: CS24SA

Date: July 04,2017

Communication System: LTE; Communication System Band: LTE Band XVII; Duty Cycle:1:1; Conv.F=5.11
Frequency: 710 MHz; Medium parameters used: $f = 750$ MHz; $\zeta = 0.89$ mho/m; $\epsilon_r = 42.33$; $\rho = 1000$ kg/m³ ;
Phantom section: Right Section
Ambient temperature (°C): 22.3, Liquid temperature (°C): 21.6

SATIMO Configuration:

- Probe: SSE5; Calibrated: 12/05/2016; Serial No.: SN 14/16 EP308
- Sensor-Surface: 4mm (Mechanical Surface Detection)
- Phantom: SAM twin phantom
- Measurement SW: OpenSAR V4_02_32

Configuration/ LTE Band XVII Mid- Touch-Right /Area Scan: Measurement grid: dx=8mm, dy=8mm
Configuration/ LTE Band XVII Mid- Touch-Right /Zoom Scan: Measurement grid: dx=8mm,dy=8mm, dz=5mm;

Area Scan	sam_direct_droit2_surf8mm.txt
Zoom Scan	5x5x7,dx=8mm dy=8mm dz=5mm
Phantom	Right head
Device Position	Cheek
Band	LTE Band XVII
Channels	Middle
Signal	OFDM (Crest factor: 1.0)

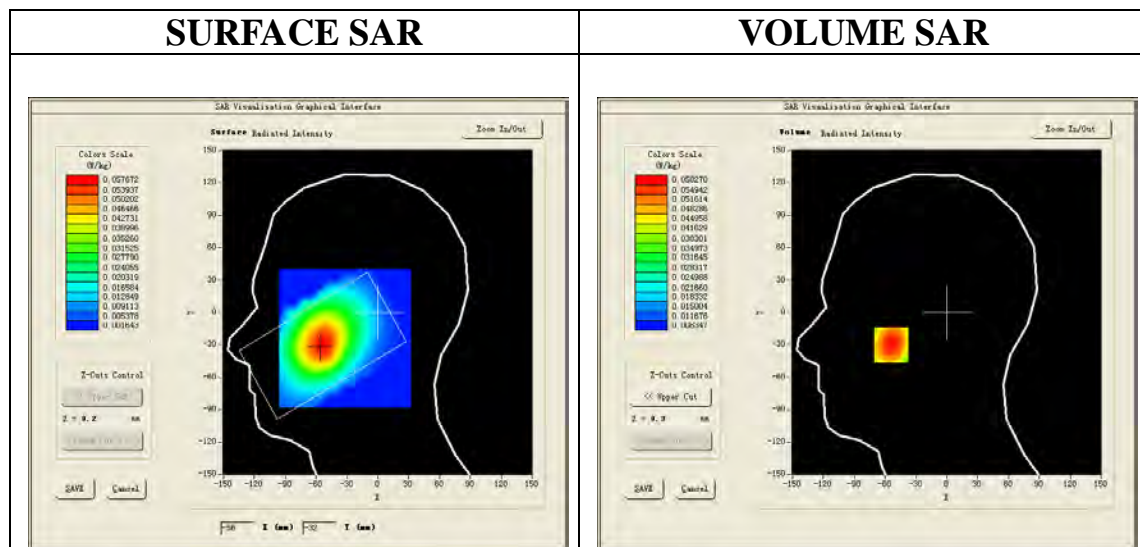

Maximum location: X=-54.00, Y=-30.00
SAR Peak: 0.07 W/kg

SAR 10g (W/Kg)	0.042679
SAR 1g (W/Kg)	0.057500

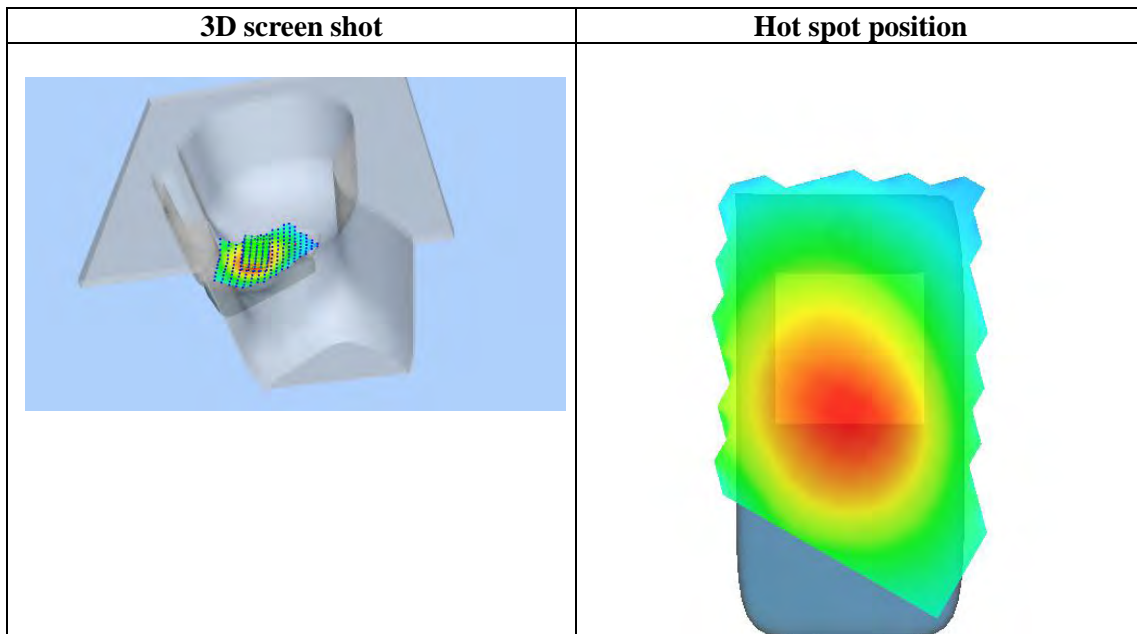
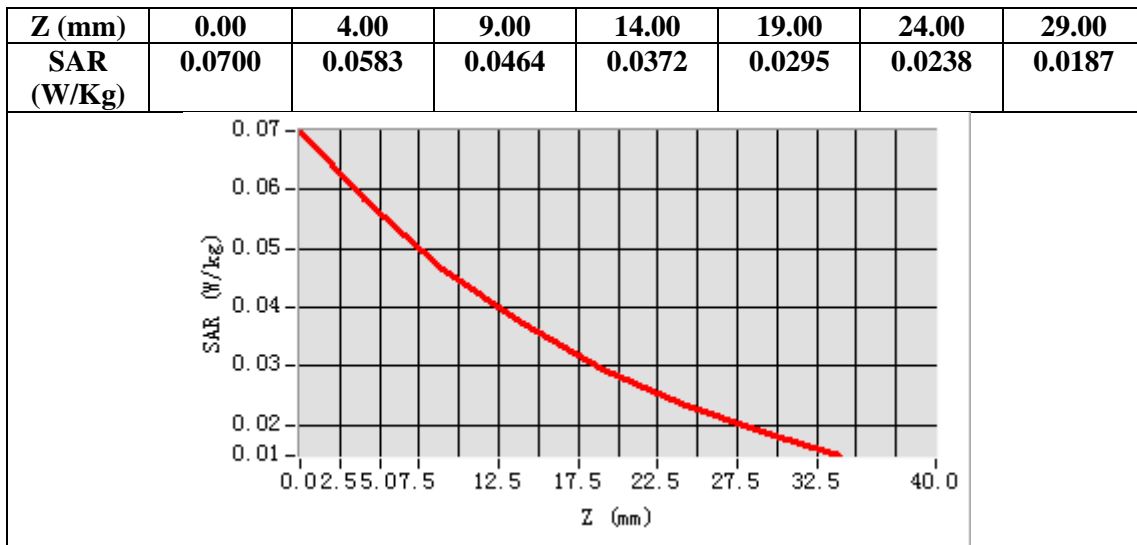

Test Laboratory: AGC Lab
LTE Band XVII Mid-Body-Back (1 RB#0)
DUT: Rugged Mobile Phone; Type: CS24SA

Date: July 04,2017

Communication System: LTE; Communication System Band: LTE Band XVII; Duty Cycle:1:1; Conv.F=5.30;
Frequency: 710 MHz; Medium parameters used: $f = 750$ MHz; $\zeta=0.95$ mho/m; $\epsilon_r =55.89$; $\rho= 1000$ kg/m³ ;
Phantom section: Flat Section
Ambient temperature (°C): 22.3, Liquid temperature (°C): 21.9

SATIMO Configuration:

- Probe: SSE5; Calibrated: 12/05/2016; Serial No.: SN 14/16 EP308
- Sensor-Surface: 4mm (Mechanical Surface Detection)
- Phantom: SAM twin phantom
- Measurement SW: OpenSAR V4_02_32

Configuration/ LTE Band XVII Mid-Body-back/Area Scan: Measurement grid: dx=8mm, dy=8mm
Configuration/ LTE Band XVII Mid-Body-back/Zoom Scan: Measurement grid: dx=8mm,dy=8mm, dz=5mm;

Area Scan	sam_direct_droit2_surf8mm.txt
Zoom Scan	5x5x7,dx=8mm dy=8mm dz=5mm
Phantom	Validation plane
Device Position	Body back
Band	LTE Band XVII
Channels	Middle
Signal	OFDM (Crest factor: 1.0)

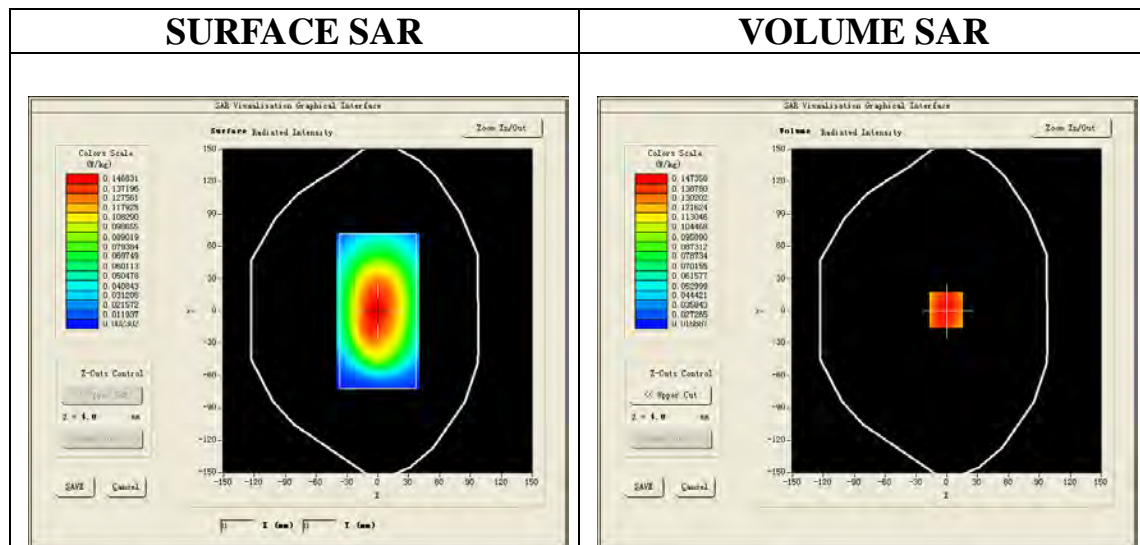

Maximum location: X=-1.00, Y=1.00
SAR Peak: 0.18 W/kg

SAR 10g (W/Kg)	0.109161
SAR 1g (W/Kg)	0.145921

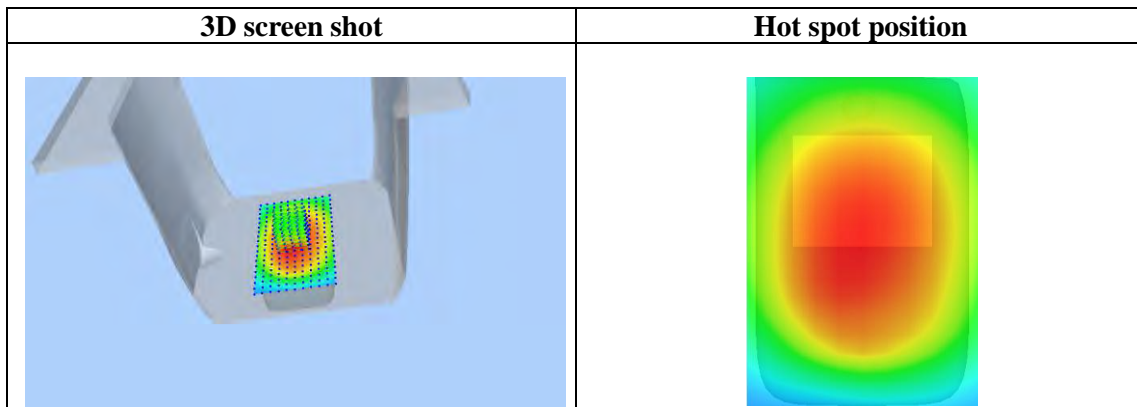
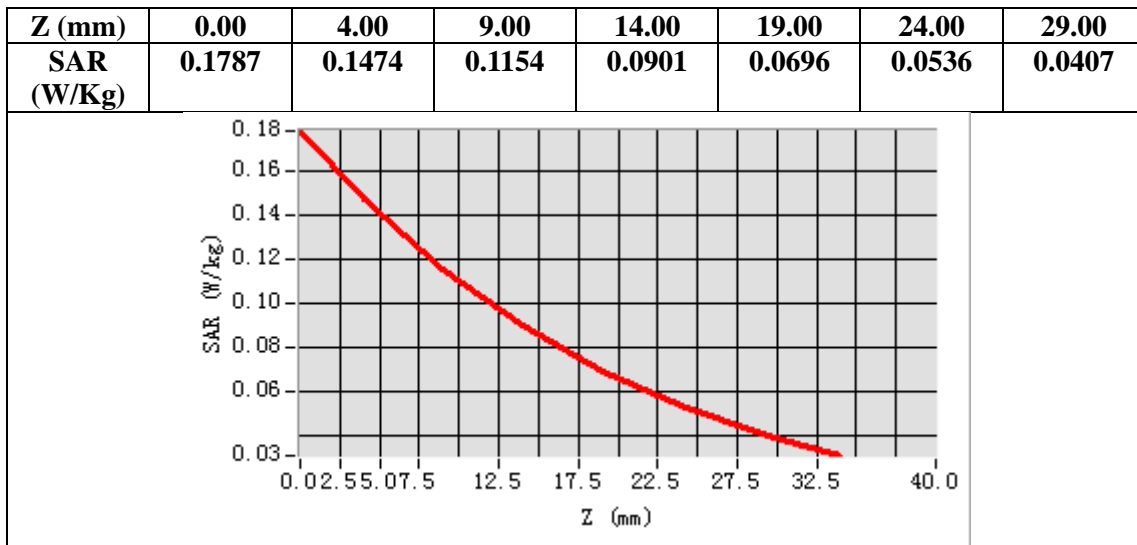

WIFI MODE

Test Laboratory: AGC Lab

Date: July 12,2017

802.11b Mid-Touch-Left

DUT: Rugged Mobile Phone; Type: CS24SA

Communication System: Wi-Fi; Communication System Band: 802.11b; Duty Cycle: 1:1; Conv.F=5.19;
Frequency: 2437 MHz; Medium parameters used: $f = 2450$ MHz; $\zeta = 1.80$ mho/m; $\epsilon_r = 39.75$, $\rho = 1000$ kg/m³ ;
Phantom section: Left Section
Ambient temperature (°C):22.1, Liquid temperature (°C): 21.6

SATIMO Configuration:

- Probe: SSE5; Calibrated: 12/05/2016; Serial No.: SN 14/16 EP308
- Sensor-Surface: 4mm (Mechanical Surface Detection)
- Phantom: SAM twin phantom
- Measurement SW: OpenSAR V4_02_32

Configuration/802.11b Mid- Touch-Left/Area Scan: Measurement grid: dx=8mm, dy=8mm

Configuration/802.11b Mid- Touch-Left/Zoom Scan: Measurement grid: dx=5mm,dy=5mm, dz=5mm

Area Scan	sam_direct_droit2_surf8mm.txt
ZoomScan	7x7x7,dx=5mm dy=5mm dz=5mm
Phantom	Left head
Device Position	Cheek
Band	2450MHz
Channels	Middle
Signal	Crest factor: 1.0

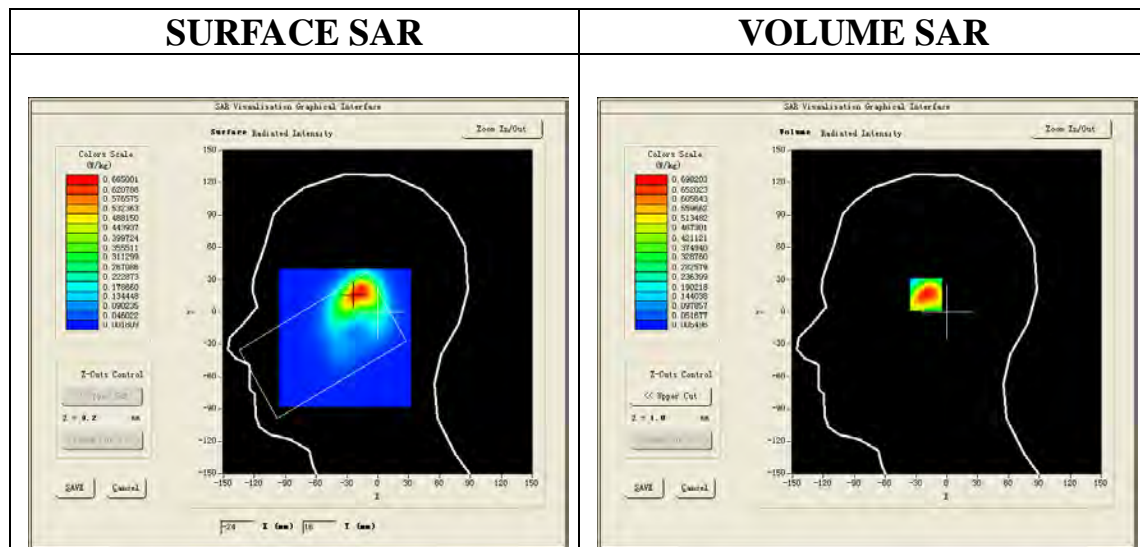

Maximum location: X=-19.00, Y=18.00

SAR Peak: 1.15 W/kg

SAR 10g (W/Kg)	0.327283
SAR 1g (W/Kg)	0.654806

Z (mm)	0.00	4.00	9.00	14.00	19.00	24.00	29.00
SAR (W/Kg)	1.1498	0.6982	0.3546	0.1812	0.0905	0.0453	0.0238

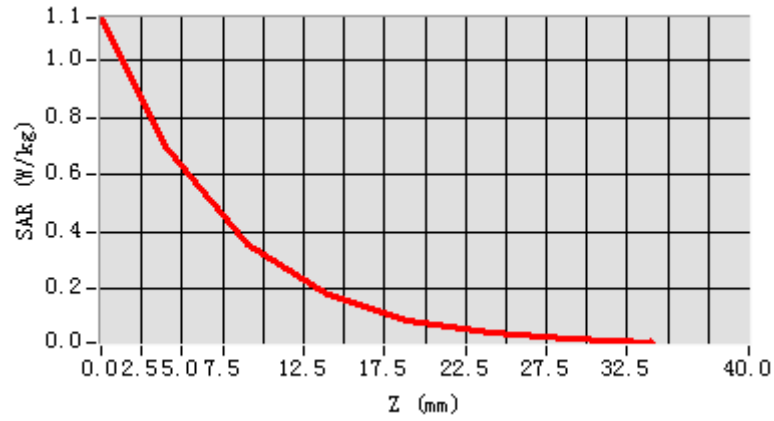

3D screen shot

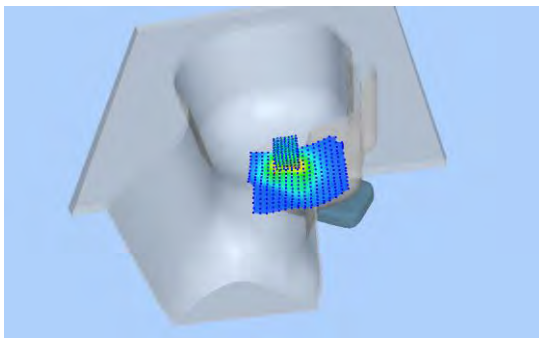

Hot spot position

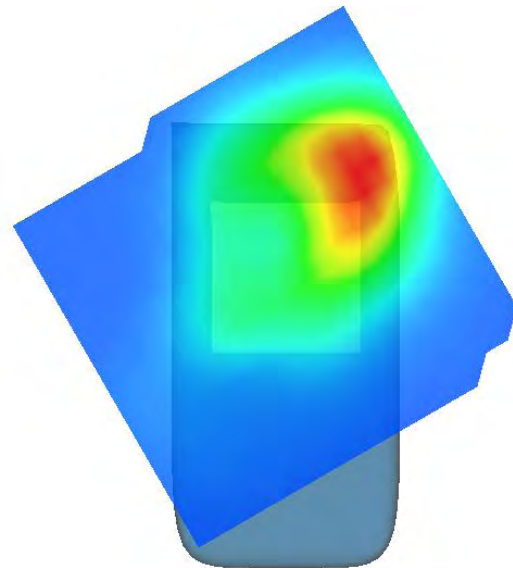

Test Laboratory: AGC Lab
802.11b Mid-Body-Worn- Front
DUT: Rugged Mobile Phone; Type: CS24SA

Date: July 12,2017

Communication System: Wi-Fi; Communication System Band: 802.11b; Duty Cycle: 1:1; Conv.F=5.33;
Frequency: 2437 MHz; Medium parameters used: $f = 2450$ MHz; $\zeta = 1.90$ mho/m; $\epsilon_r = 53.95$; $\rho = 1000$ kg/m³ ;
Phantom section: Flat Section
Ambient temperature (°C):22.1, Liquid temperature (°C): 21.7

SATIMO Configuration:

- Probe: SSE5; Calibrated: 12/05/2016; Serial No.: SN 14/16 EP308
- Sensor-Surface: 4mm (Mechanical Surface Detection)
- Phantom: SAM twin phantom
- Measurement SW: OpenSAR V4_02_32

Configuration/802.11b Mid- Body- Front /Area Scan: Measurement grid: dx=8mm, dy=8mm
Configuration/802.11b Mid- Body- Front /Zoom Scan: Measurement grid: dx=5mm,dy=5mm, dz=5mm;

Area Scan	sam_direct_droit2_surf8mm.txt
ZoomScan	7x7x7,dx=5mm dy=5mm dz=5mm
Phantom	Validation plane
Device Position	Body front
Band	2450MHz
Channels	Middle
Signal	Crest factor: 1.0

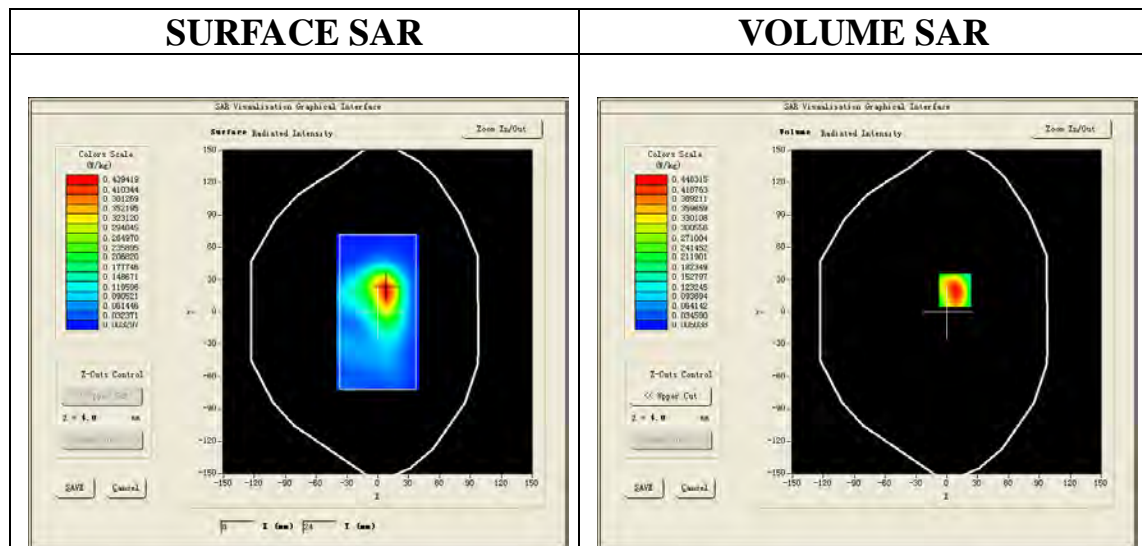

Maximum location: X=8.00, Y=20.00
SAR Peak: 0.73 W/kg

SAR 10g (W/Kg)	0.215536
SAR 1g (W/Kg)	0.420539

Z (mm)	0.00	4.00	9.00	14.00	19.00	24.00	29.00
SAR (W/Kg)	0.7366	0.4483	0.2289	0.1143	0.0584	0.0300	0.0161

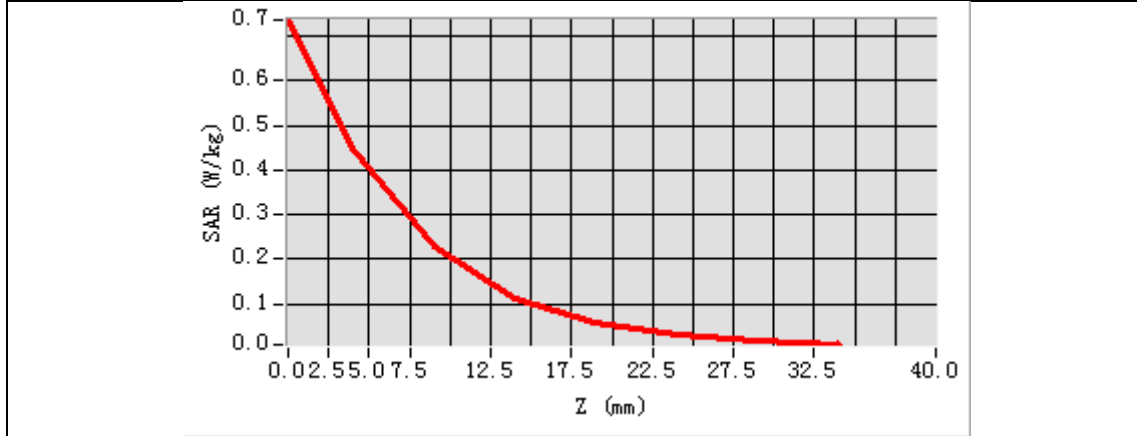

3D screen shot	Hot spot position
<p>A 3D perspective view of a grey, L-shaped device. A grid of colored dots is overlaid on the flat surface of the shorter arm, representing the SAR distribution. The colors range from blue (low SAR) to red (high SAR), with the highest concentration in the center of the grid.</p>	<p>A 2D heatmap showing the SAR distribution on the device's surface. The color scale ranges from blue (low SAR) to red (high SAR). The highest SAR value (red) is concentrated in a central region, surrounded by yellow and green, indicating a hot spot.</p>

Repeated SAR

Test Laboratory: AGC Lab

Date: June 28, 2017

GPRS 1900 Low-Body-Front (2up) <SIM 1>

DUT: Rugged Mobile Phone; Type: CS24SA

Communication System: GPRS-2Slot; Communication System Band: PCS 1900; Duty Cycle: 1:4.2; Conv.F=5.34;
Frequency: 1850.2MHz; Medium parameters used: $f = 1900$ MHz; $\zeta = 1.45$ mho/m; $\epsilon_r = 55.15$; $\rho = 1000$ kg/m³ ;
Phantom section: Flat Section
Ambient temperature (°C): 22.1, Liquid temperature (°C): 21.5

SATIMO Configuration:

- Probe: SSE5; Calibrated: 07/05/2016; Serial No.: SN 14/16 EP307
- Sensor-Surface: 4mm (Mechanical Surface Detection)
- Phantom: SAM twin phantom
- Measurement SW: OpenSAR V4_02_35

Configuration/GPRS1900 Low -Body- Front /Area Scan: Measurement grid: dx=8mm, dy=8mm

Configuration/GPRS1900 Low -Body- Front /Zoom Scan: Measurement grid: dx=8mm,dy=8mm, dz=5mm;

Area Scan	sam_direct_droit2_surf8mm.txt
Zoom Scan	5x5x7,dx=8mm dy=8mm dz=5mm,Complete
Phantom	Validation plane
Device Position	Body Front
Band	PCS 1900
Channels	Low
Signal	TDMA (Crest factor: 4.0)

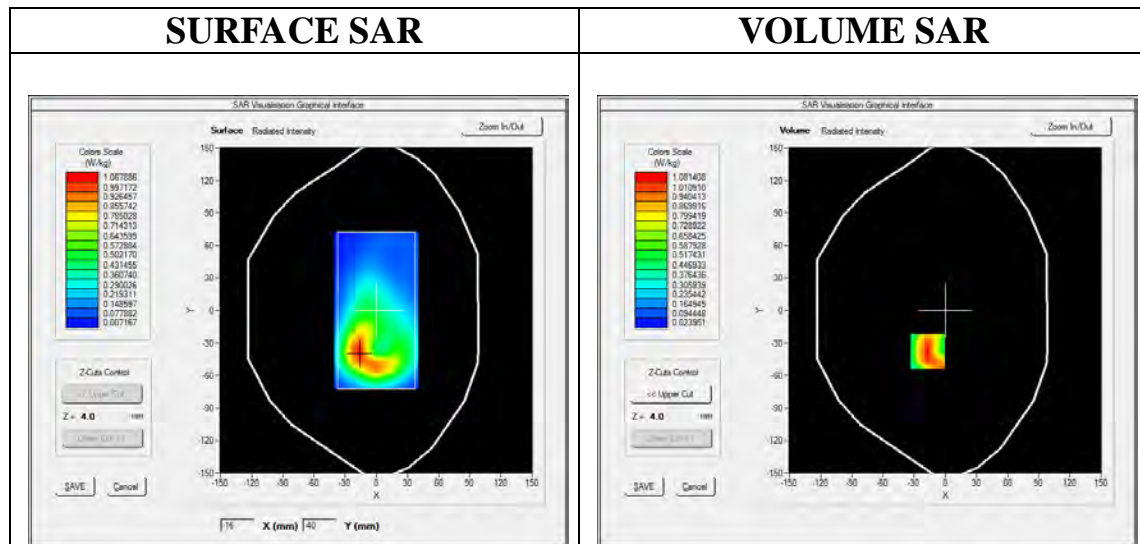

Maximum location: X=-17.00, Y=-38.00

SAR Peak: 1.68 W/kg

SAR 10g (W/Kg)	0.553242
SAR 1g (W/Kg)	1.021099

Z (mm)	0.00	4.00	9.00	14.00	19.00	24.00	29.00
SAR (W/Kg)	1.6632	1.0814	0.6134	0.3527	0.2000	0.1195	0.0704

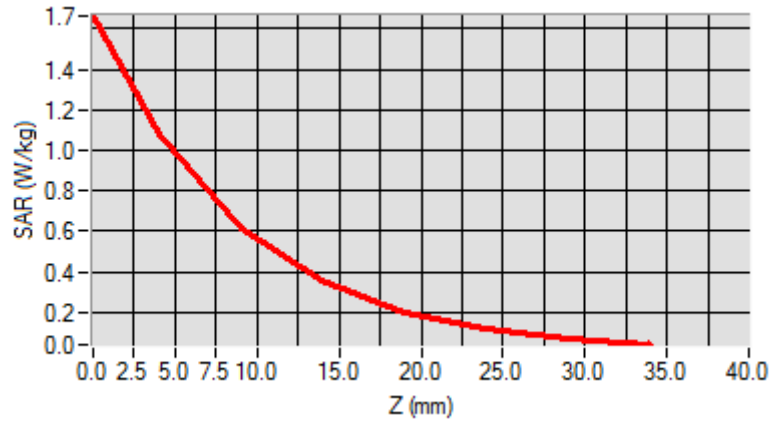

3D screen shot	Hot spot position
<p>A 3D perspective view of a grey, rectangular device. A grid of small colored dots is overlaid on the front face, representing a SAR distribution. The colors range from blue (low SAR) to red (high SAR), with the highest concentration in the center.</p>	<p>A 2D heatmap showing the SAR distribution. The color scale transitions from blue at the top to red at the bottom, with a prominent red/orange hot spot in the lower central region.</p>

Test Laboratory: AGC Lab
WCDMA Band II Low-Body-Towards Phantom (RMC 12.2kbps)
DUT: Rugged Mobile Phone; Type: CS24SA

Date: June 28, 2017

Communication System: UMTS; Communication System Band: Band II UTRA/FDD ;Duty Cycle:1:1; Conv.F=5.34;
Frequency: 1852.4 MHz; Medium parameters used: $f = 1900$ MHz; $\zeta = 1.47$ mho/m; $\epsilon_r = 54.67$; $\rho = 1000$ kg/m³ ;
Phantom section: Flat Section
Ambient temperature (°C): 22.1, Liquid temperature (°C): 21.5

SATIMO Configuration:

- Probe: SSE5; Calibrated: 07/05/2016; Serial No.: SN 14/16 EP307
- Sensor-Surface: 4mm (Mechanical Surface Detection)
- Phantom: SAM twin phantom
- Measurement SW: OpenSAR V4_02_35

Configuration/ WCDMA band II Low-Body-Front /Area Scan: Measurement grid: dx=8mm, dy=8mm
Configuration/ WCDMA band II Low-Body-Front /Zoom Scan: Measurement grid: dx=8mm,dy=8mm, dz=5mm;

Area Scan	sam_direct_droit2_surf8mm.txt
ZoomScan	5x5x7,dx=8mm dy=8mm dz=5mm,Complete
Phantom	Validation plane
Device Position	Body Front
Band	WCDMA band II
Channels	Low
Signal	CDMA (Crest factor: 1.0)

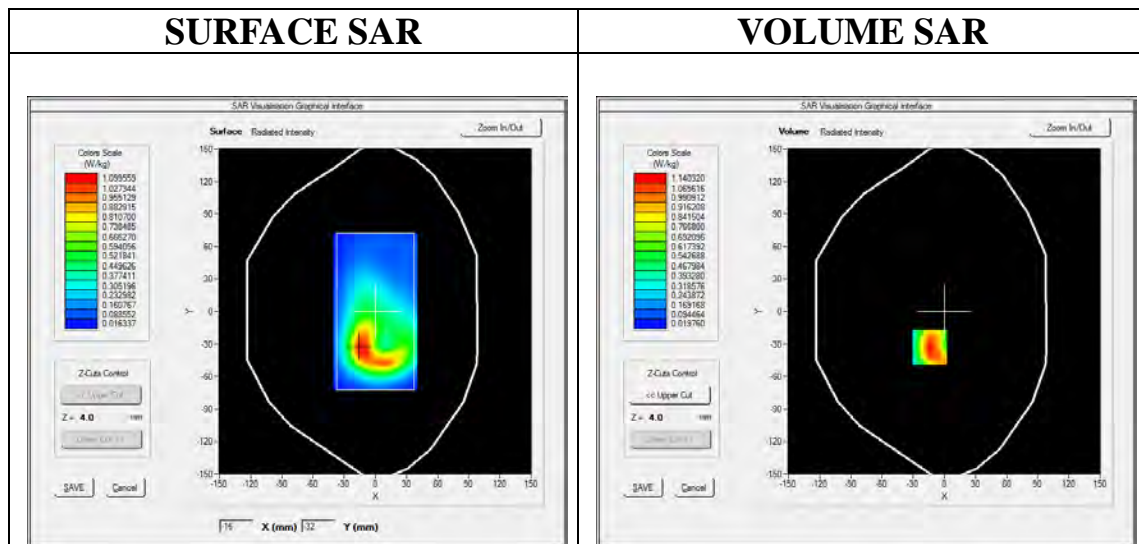

Maximum location: X=-14.00, Y=-33.00

SAR Peak: 1.83 W/kg

SAR 10g (W/Kg)	0.580190
SAR 1g (W/Kg)	1.088805

Z (mm)	0.00	4.00	9.00	14.00	19.00	24.00	29.00
SAR (W/Kg)	1.7751	1.1403	0.6377	0.3649	0.2057	0.1174	0.0676

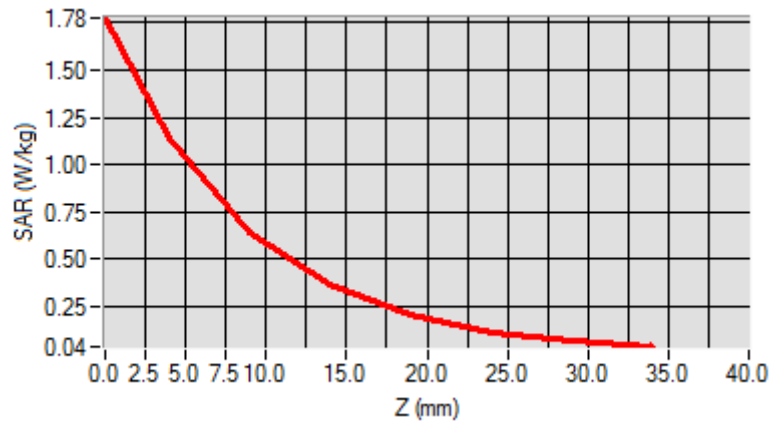

3D screen shot	Hot spot position
<p>A 3D perspective view of a grey, rectangular device. A grid of small colored squares is overlaid on the front face, representing a SAR distribution. The colors range from blue (low SAR) to red (high SAR), with the highest concentration (red) located in the lower-left quadrant of the device's front face.</p>	<p>A 2D heatmap of the device's front face. The color scale is the same as in the 3D view, with red indicating the highest SAR values. The hot spot is clearly visible as a red and yellow area in the lower-left portion of the device's surface.</p>

APPENDIX C. TEST SETUP PHOTOGRAPHS

LEFT-CHEEK TOUCH

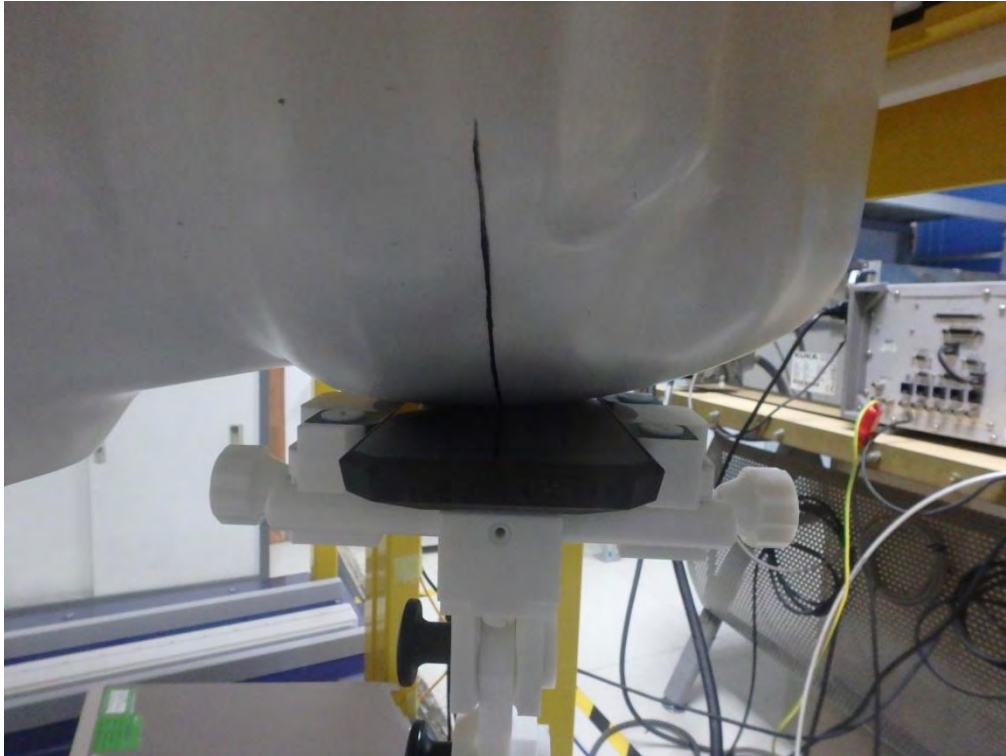

LEFT-TILT 15°

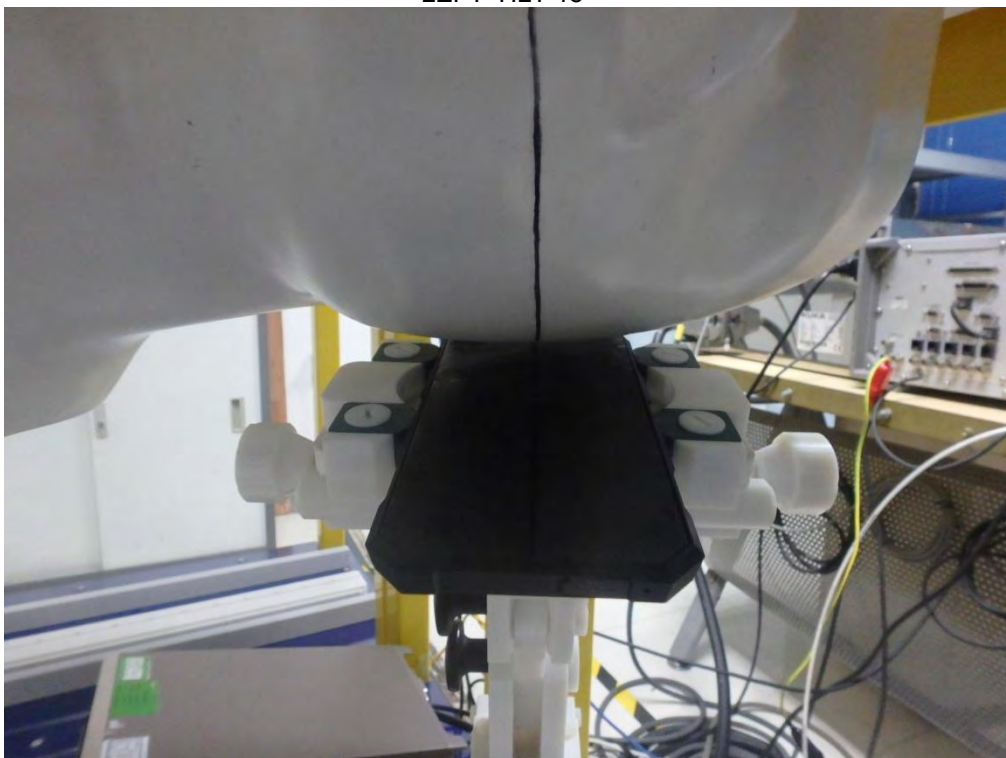

RIGHT- CHEEK TOUCH

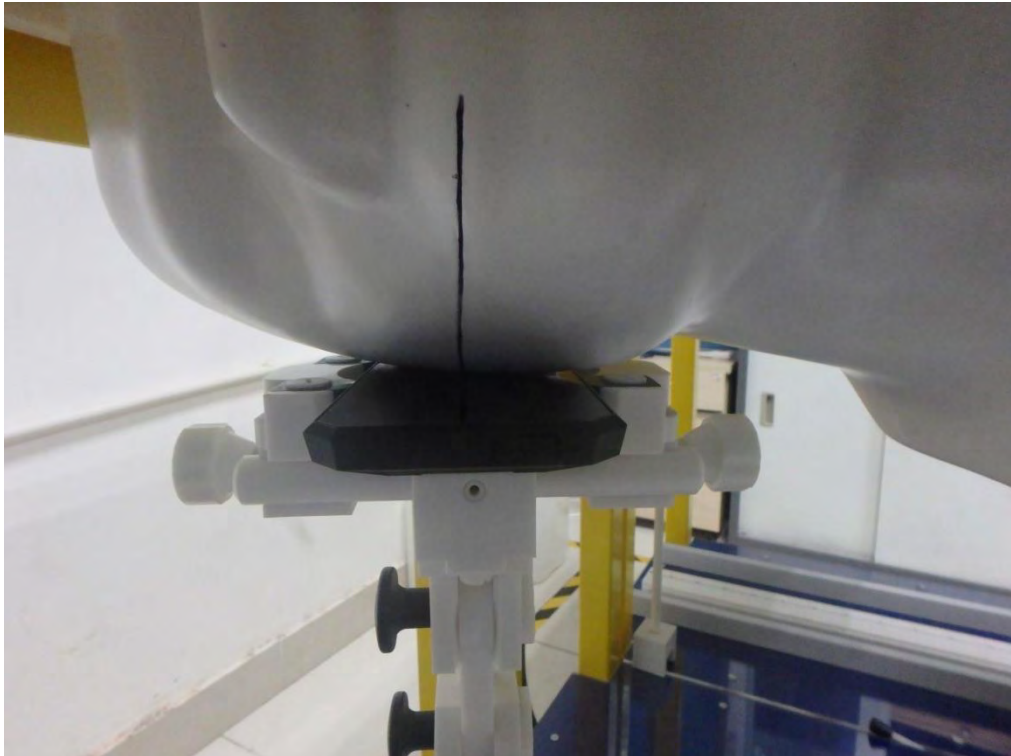

RIGHT-TILT 15°

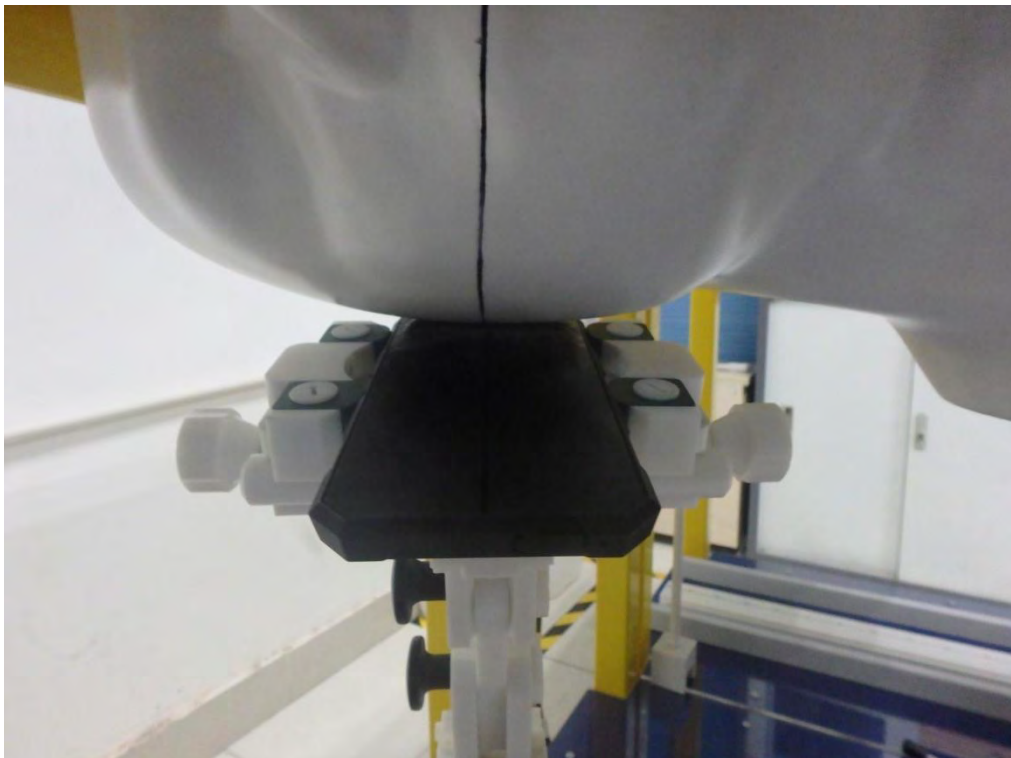

Body Back 5mm

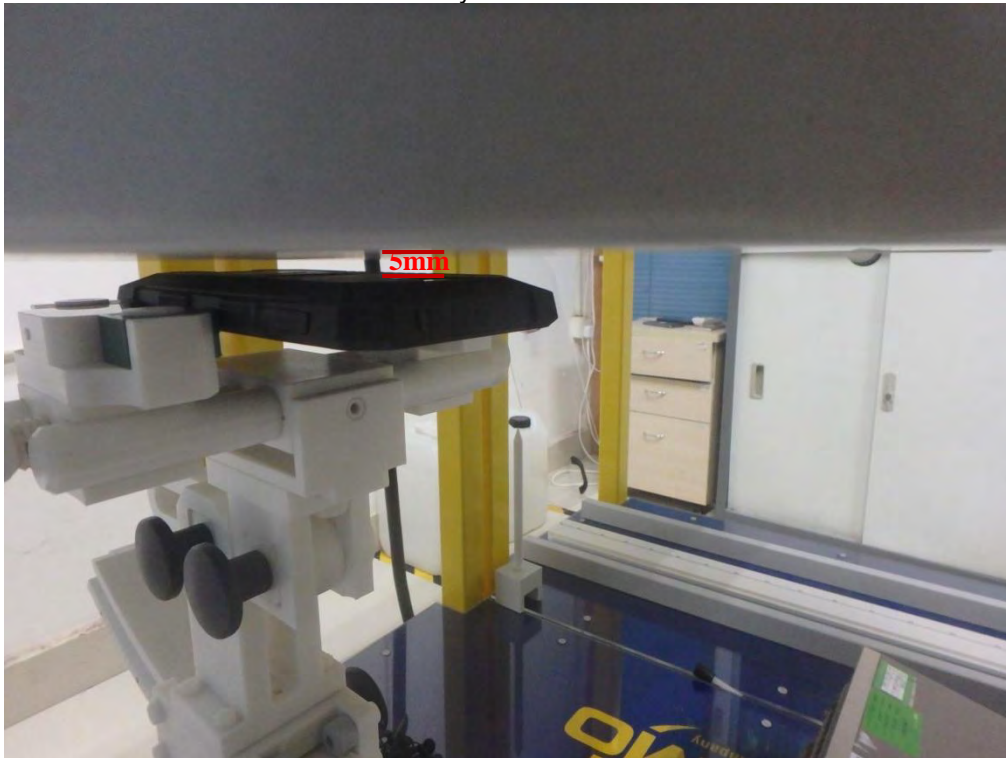

Body Front 5mm

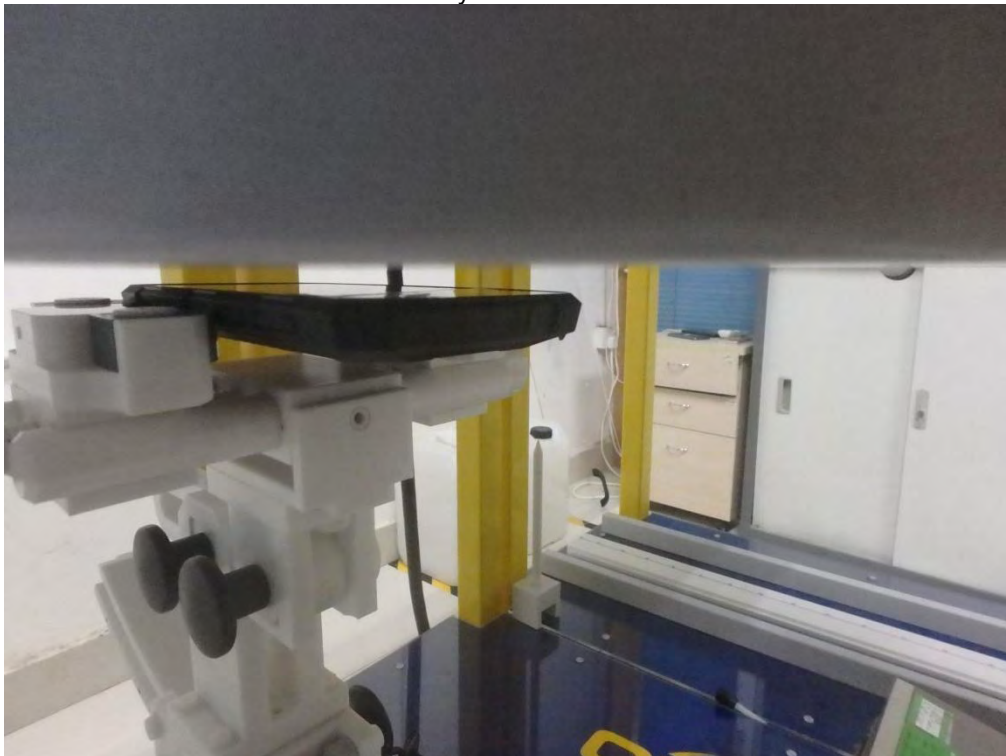

Edge 1(Top) 10mm-Hotspot Mode

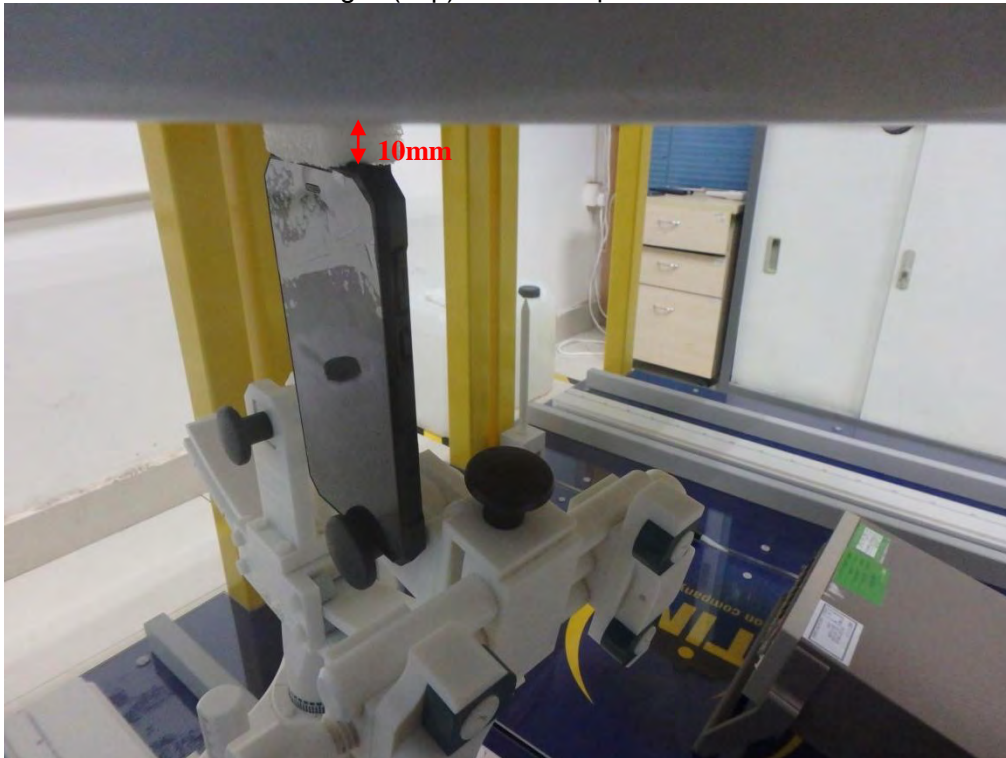

Edge 2(Right) 10mm-Hotspot Mode



Edge 3(Bottom) 10mm-Hotspot Mode





Edge 4(Left) 10mm-Hotspot Mode

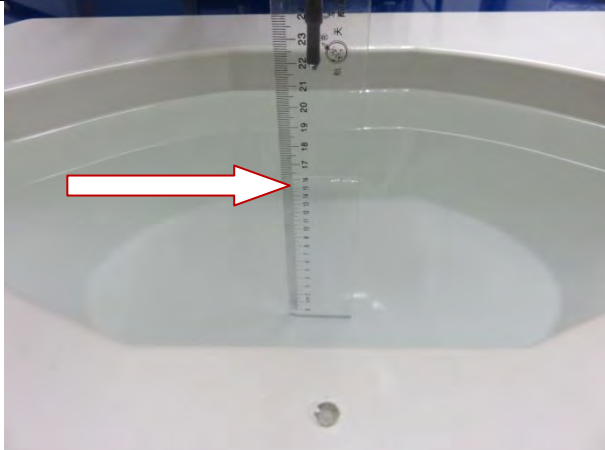
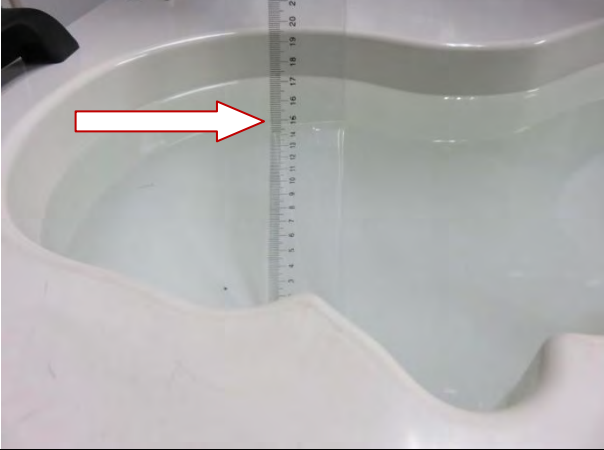

DEPTH OF THE LIQUID IN THE PHANTOM—ZOOM IN

Note : The position used in the measurement were according to IEEE 1528-2013

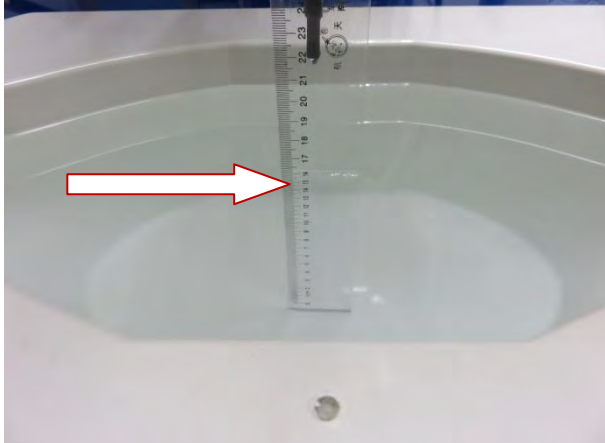
<p>835MHz head</p>  A photograph showing the measurement of liquid depth in the head region of a phantom. A ruler is placed vertically against the inner wall of the phantom. A white arrow points to the top surface of the liquid, which is at approximately the 15.5 cm mark on the ruler.	<p>835MHz body</p>  A photograph showing the measurement of liquid depth in the body region of a phantom. A ruler is placed vertically against the inner wall. A white arrow points to the top surface of the liquid, which is at approximately the 18.5 cm mark on the ruler.
<p>1900MHz head</p>  A photograph showing the measurement of liquid depth in the head region of a phantom. A ruler is placed vertically against the inner wall. A white arrow points to the top surface of the liquid, which is at approximately the 15.5 cm mark on the ruler.	<p>1900MHz body</p>  A photograph showing the measurement of liquid depth in the body region of a phantom. A ruler is placed vertically against the inner wall. A white arrow points to the top surface of the liquid, which is at approximately the 18.5 cm mark on the ruler.
<p>2450MHz head</p>  A photograph showing the measurement of liquid depth in the head region of a phantom. A ruler is placed vertically against the inner wall. A white arrow points to the top surface of the liquid, which is at approximately the 15.5 cm mark on the ruler.	<p>2450MHz body</p>  A photograph showing the measurement of liquid depth in the body region of a phantom. A ruler is placed vertically against the inner wall. A white arrow points to the top surface of the liquid, which is at approximately the 18.5 cm mark on the ruler.

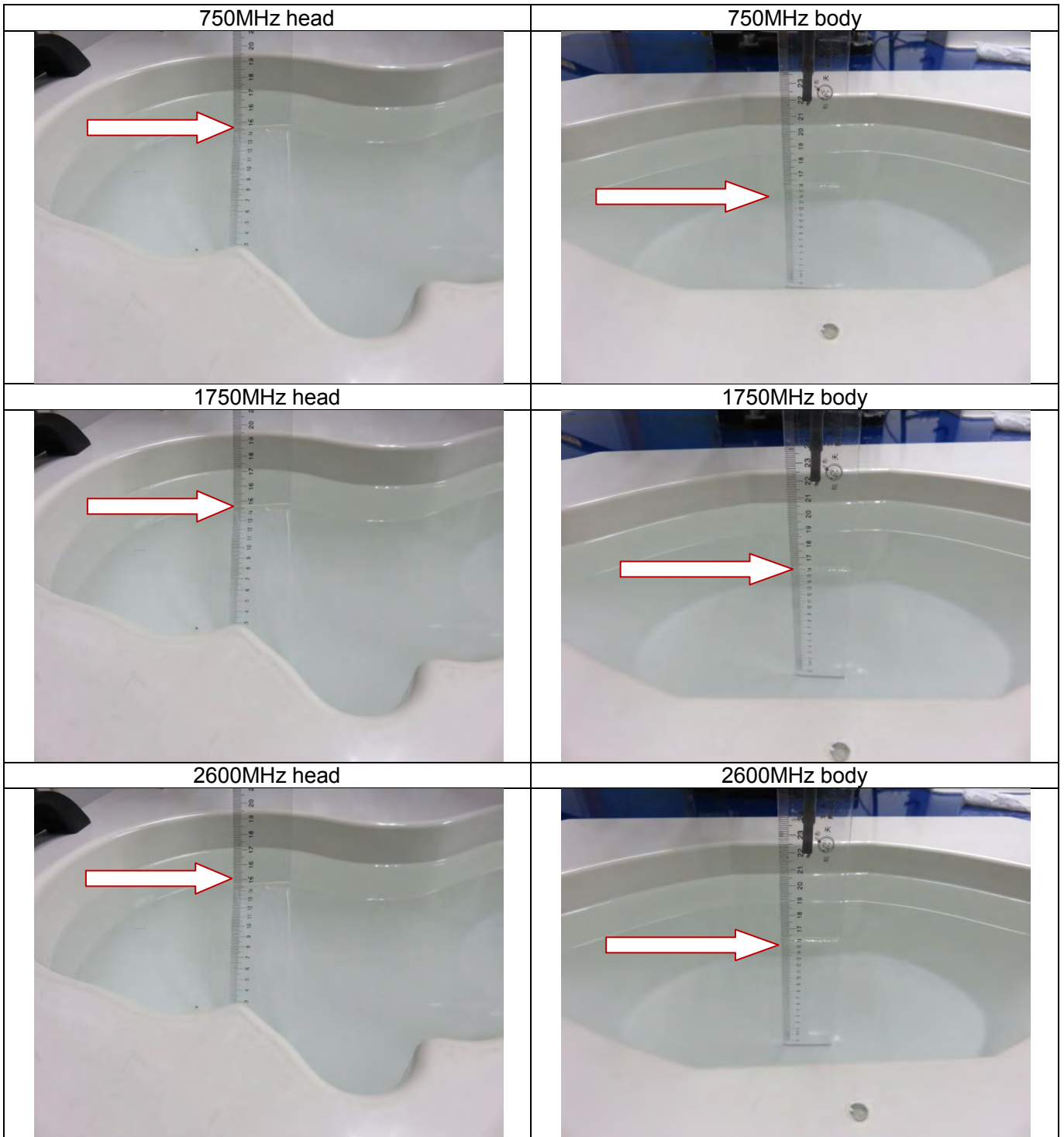

APPENDIX D. CALIBRATION DATA

Refer to Attached files.