

FCC SAR Measurement and Test Report

For

Cyrus Technology GmbH

Hergelsbendenstrasse 49, 52080 Aachen, Germany

FCC ID: 2AI3KCS22XA

Test Standards: FCC Part 2.1093
ANSI / IEEE C95.1 :2005+A1:2010
ANSI / IEEE C95.3 : 2002(R2008)
IEEE 1528 :2013

Product Description: Rugged Phone

Tested Model: CS22XA

Report No.: WTX19X08058778W-13

Sample Received Date: 2019-08-23

Tested Date: 2019-08-23 to 2019-09-25

Issued Date: 2019-09-25

Tested By: Ruler Liu / Engineer

Reviewed By: Silin Chen / EMC Manager

Approved & Authorized By: Jandy So / PSQ Manager

Ruler Liu

Silin Chen

Jandy So

Prepared By:

Shenzhen SEM Test Technology Co., Ltd.

1/F, Building A, Hongwei Industrial Park, Liuxian 2nd Road,
Bao'an District, Shenzhen, P.R.C. (518101)

Tel.: +86-755-33663308 Fax.: +86-755-33663309 Website: www.semtest.com.cn

Note: This test report is limited to the above client company and the product model only. It may not be duplicated without prior permitted by Shenzhen SEM Test Technology Co., Ltd.

TABLE OF CONTENTS

1. General Information3

 1.1 Product Description for Equipment Under Test (EUT).....3

 1.2 Test Standards7

 1.3 Test Methodology.....7

 1.4 Test Facility7

2. Summary of Test Results8

3. Specific Absorption Rate (SAR).....10

 3.1 Introduction.....10

 3.2 SAR Definition10

4. SAR Measurement System.....11

 4.1 The Measurement System11

 4.2 Probe.....11

 4.3 Probe Calibration Process.....13

 4.4 Phantom14

 4.5 Device Holder.....14

 4.6 Test Equipment List.....15

5. Tissue Simulating Liquids.....16

 5.1 Composition of Tissue Simulating Liquid.....16

 5.2 Tissue Dielectric Parameters for Head and Body Phantoms.....18

 5.3 Tissue Calibration Result.....19

6. SAR Measurement Evaluation20

 6.1 Purpose of System Performance Check.....20

 6.2 System Setup20

 6.3 Validation Results.....21

7. EUT Testing Position23

 7.1 Define Two Imaginary Lines on The Handset.....23

 7.2 Cheek Position24

 7.3 Tilted Position.....24

 7.4 Body Worn Position25

 7.5 EUT Antenna Position25

 7.6 EUT Testing Position.....27

8. SAR Measurement Procedures.....28

 8.1 Measurement Procedures28

 8.2 Spatial Peak SAR Evaluation28

 8.3 Area & Zoom Scan Procedures.....29

 8.4 Volume Scan Procedures.....29

 8.5 SAR Averaged Methods29

 8.6 Power Drift Monitoring.....29

9. SAR Test Result30

 9.1 Conducted RF Output Power30

 9.2 Test Results for Standalone SAR Test.....102

 9.3 Simultaneous Multi-band Transmission SAR Analysis128

10. Measurement Uncertainty150

 10.1 Uncertainty for EUT SAR Test.....150

 10.2 Uncertainty for System Performance Check.....151

Annex A. Plots of System Performance Check153

Annex B. Plots of SAR Measurement.....189

Annex C. EUT Photos300

Annex D. Test Setup Photos302

Annex E. Calibration Certificate.....308

1. General Information

1.1 Product Description for Equipment Under Test (EUT)

Client Information

Applicant: Cyrus Technology GmbH
Address of applicant: Hergelsbendenstrasse 49, 52080 Aachen, Germany

Manufacturer: Cyrus Technology GmbH
Address of manufacturer: Hergelsbendenstrasse 49, 52080 Aachen, Germany

General Description of EUT:	
Product Name:	Rugged Phone
Brand Name:	Cyrus
Model No.:	CS22XA
Adding Model(s):	/
Rated Voltage:	DC 3.85V by Battery
Battery:	4400mAh
Software Version:	CS22XA_ROW_1.0.2
Hardware Version:	L915-MB-V1.1
Device Category:	Portable Device
<i>Note: The test data is gathered from a production sample provided by the manufacturer.</i>	

Technical Characteristics of EUT:	
2G	
Support Networks:	GSM, GPRS, EDGE
Support Band:	GSM850/PCS1900
Uplink Frequency:	GSM/GPRS/EDGE 850: 824~849MHz GSM/GPRS/EDGE 1900: 1850~1910MHz
Downlink Frequency:	GSM/GPRS/EDGE 850: 869~894MHz GSM/GPRS/EDGE 1900: 1930~1990MHz
RF Output Power:	GSM850: 32.64dBm, GSM1900: 29.95dBm EDGE850: 26.69dBm, EDGE1900: 24.61dBm
Type of Modulation:	GMSK, 8PSK
Type of Antenna:	Integral Antenna
Antenna Gain:	GSM850: 1.25dBi; GSM1900: 1.25dBi
GPRS/EDGE Class:	Class 12
3G	
Support Networks:	WCDMA, HSDPA, HSUPA
Support Band:	WCDMA Band 2, WCDMA Band 5, WCDMA Band 4
Uplink Frequency:	WCDMA Band 2: 1850~1910MHz WCDMA Band 5: 824~849MHz WCDMA Band 4: 1710~1755MHz
Downlink Frequency:	WCDMA Band 2: 1930~1990MHz WCDMA Band 5: 869~894MHz WCDMA Band 4: 2110~2155MHz
RF Output Power:	WCDMA Band 2: 22.29dBm, WCDMA Band 4: 21.36dBm WCDMA Band 5: 22.45dBm
Type of Modulation:	BPSK
Antenna Type:	Integral Antenna
Antenna Gain:	WCDMA Band 2: 1.25dBi, WCDMA Band 4: 1.28dBi WCDMA Band 5: 1.25dBi
4G	
Support Networks:	FDD-LTE
Support Band:	FDD-LTE Band 2, 4, 5, 7, 12, 13, 17, 25,26,30,66 TDD-LTE Band 40
Uplink Frequency:	FDD-LTE Band 2: Tx: 1850-1910MHz, FDD-LTE Band 4: Tx: 1710-1755MHz, FDD-LTE Band 5: Tx: 824-849MHz, FDD-LTE Band 7: Tx: 2500-2570MHz, FDD-LTE Band 12: Tx: 699-719MHz, FDD-LTE Band 13: Tx: 777-787MHz, FDD-LTE Band 17: Tx: 704-716MHz

	<p>FDD-LTE Band 25: Tx: 1850-1915MHz, FDD-LTE Band 26: Tx: 814-864MHz&824-849MHz FDD-LTE Band 30: Tx: 2300-2310MHz, TDD-LTE Band 40: Tx: 2305-2315MHz&2350-2360MHz FDD-LTE Band 66: Tx: 1710-1770MHz,</p>
Downlink Frequency:	<p>FDD-LTE Band 2: Rx: 1930-1990MHz, FDD-LTE Band 4: Rx: 2110-2155MHz, FDD-LTE Band 5: Rx: 869-894MHz, FDD-LTE Band 7: Rx: 2620-2690MHz, FDD-LTE Band 12: Rx: 729-749MHz, FDD-LTE Band 13: Rx: 746-756MHz, FDD-LTE Band 17: Rx: 734-746MHz FDD-LTE Band 25: Rx: 1930-1995MHz, FDD-LTE Band 26: Rx: 814-864MHz&824-849MHz FDD-LTE Band 30: Rx: 2300-2310MHz, TDD-LTE Band 40: Rx: 2305-2315MHz&2350-2360MHz FDD-LTE Band 66: Rx: 1710-1770MHz,</p>
RF Output Power:	<p>FDD-LTE Band 2: 22.77dBm, FDD-LTE Band 4: 23.30dBm, FDD-LTE Band 5: 23.45dBm, FDD-LTE Band 7: 23.28dBm, FDD-LTE Band 12: 22.91dBm, FDD-LTE Band 13: 24.11dBm, FDD-LTE Band 17: 23.34dBm FDD-LTE Band 25: 22.48dBm, FDD-LTE Band 26 (814-864MHz): 23.41dBm, FDD-LTE Band 26 (824-849MHz): 23.59dBm, FDD-LTE Band 30: 23.89dBm, TDD-LTE Band 40 (2305-2315MHz): 22.85dBm, TDD-LTE Band 40 (2350-2360MHz): 22.97dBm, FDD-LTE Band 66: 25.47dBm,</p>
Type of Modulation:	QPSK, 16QAM
Antenna Type:	Integral Antenna
Antenna Gain:	<p>FDD-LTE Band 2: 1.25dBi, FDD-LTE Band 4: 1.28dBi, FDD-LTE Band 5: 1.25dBi, FDD-LTE Band 7: 1.64dBi, FDD-LTE Band 12: 1.01dBi, FDD-LTE Band 13: 1.23dBi, FDD-LTE Band 17: 1.11dBi, FDD-LTE Band 25: 1.38dBi, FDD-LTE Band 26: 1.25dBi, FDD-LTE Band 30: 1.52dBi, TDD-LTE Band 40: 1.61dBi,</p>

	FDD-LTE Band 66: 1.61dBi,
WIFI(2.4G)	
Support Standards:	802.11b, 802.11g, 802.11n
Frequency Range:	2412-2462MHz for 11b/g/n(HT20) 2422-2452MHz for 11n(HT40)
RF Output Power:	17.52dBm (Conducted)
Type of Modulation:	CCK, OFDM, QPSK, BPSK, 16QAM, 64QAM
Data Rate:	1-11Mbps, 6-54Mbps, up to 150Mbps
Quantity of Channels:	11 for 802.11b/g/n(HT20) 7 for 802.11n(HT40)
Channel Separation:	5MHz
Antenna Type:	Integral Antenna
Antenna Gain:	2.12dBi
Bluetooth	
Bluetooth Version:	V5.0
Frequency Range:	2402-2480MHz
RF Output Power:	7.857dBm (Conducted)
Data Rate:	1Mbps, 2Mbps, 3Mbps
Modulation:	GFSK, Pi/4 QDPSK, 8DPSK
Quantity of Channels:	79/40
Channel Separation:	1MHz/2MHz
Antenna Type:	Integral Antenna
Antenna Gain:	2.12dBi
WIFI(5G)	
Support Standards:	802.11a, 802.11n-HT20/40,802.11ac-HT80
Frequency Range:	Band 1: 5180-5240MHz,Band 2: 5260-5320MHz, Band 3: 5500-5700MHz,Band 4: 5745-5825MHz
RF Output Power:	14.74dBm (Conducted)
Type of Modulation:	QPSK, 16QAM, 64QAM
Type of Antenna:	Internal Antenna
Antenna Gain:	0.85dBi
NFC	
Support Standards:	NFC
Frequency Range:	13.56MHz
Max. Field Strength:	58.04dBuV/m (at 3m)
Antenna Type:	Integral Antenna

1.2 Test Standards

The following report is prepared on behalf of the Cyrus Technology GmbH in accordance with FCC 47 CFR Part 2.1093, ANSI/IEEE C95.1-2005, ANSI / IEEE C95.3 :2002, IEEE 1528-2013, KDB 447498 D01 v06, KDB 648474 D04 v01r03, KDB 248227 D01 v02r02, KDB 941225 D01 v03r01, KDB 941225 D05 v02r05 ,KDB 941225 D06 v02r01, and KDB 865664 D01 v01r04 and KDB 865664 D02 v01r02.

The objective is to determine compliance with FCC Part 2.1093 of the Federal Communication Commissions rules.

Maintenance of compliance is the responsibility of the manufacturer. Any modification of the product, which result in lowering the emission, should be checked to ensure compliance has been maintained.

1.3 Test Methodology

All measurements contained in this report were conducted with KDB 865664 D01 v01r04 and KDB 865664 D02 v01r02. The public notice KDB 447498 D01 v06 for Mobile and Portable Devices RF Exposure Procedure also.

1.4 Test Facility

FCC – Registration No.: 125990

Shenzhen SEM Test Technology Co., Ltd. Laboratory has been recognized to perform compliance testing on equipment subject to the Commissions Declaration Of Conformity (DOC). The Designation Number is CN5010, and Test Firm Registration Number is 125990.

Industry Canada (IC) Registration No.: 11464A

The 3m Semi-anechoic chamber of Shenzhen SEM.Test Technology Co., Ltd. has been registered by Certification and Engineering Bureau of Industry Canada for radio equipment testing with Registration No.: 11464A.

2. Summary of Test Results

The maximum results of Specific Absorption Rate (SAR) have found during testing are as follows:

Frequency Band	Head SAR	Body-worn (10mm Gap)	Hotspot (10mm Gap)	SAR _{1g} Limit (W/kg)
	Maximum SAR _{1g} (W/kg)	Maximum SAR _{1g} (W/kg)	Maximum SAR _{1g} (W/kg)	
GSM850	1.073	0.552	1.280	1.6
GSM1900	0.576	0.602	1.281	1.6
WCDMA Band 2	0.550	0.925	0.925	1.6
WCDMA Band 5	0.198	0.274	0.274	1.6
WCDMA Band 4	0.444	1.113	1.113	1.6
FDD-LTE 2	0.067	0.495	1.030	1.6
FDD-LTE 4	0.092	0.400	0.731	1.6
FDD-LTE 5	0.003	0.032	0.032	1.6
FDD-LTE 7	0.392	1.093	1.093	1.6
FDD-LTE 12	0.016	0.042	0.042	1.6
FDD-LTE 13	0.007	0.035	0.035	1.6
FDD-LTE 17	0.013	0.036	0.036	1.6
FDD-LTE 25	0.039	0.582	0.998	1.6
FDD-LTE 26	0.008	0.057	0.057	1.6
FDD-LTE 30	0.200	0.357	0.357	1.6
TDD-LTE 40	0.096	0.126	0.126	1.6
FDD-LTE 66	0.057	0.586	0.852	1.6
WLAN 2.4G	0.363	0.171	0.171	1.6
WLAN 5.2G	0.371	0.109	/	1.6
WLAN 5.3G	0.138	0.189	/	1.6
WLAN 5.6G	0.319	0.373	/	1.6
WLAN 5.8G	0.110	0.226	/	1.6
Simultaneous Transmission	1.392	1.486	1.507	1.6

Front-of the face SAR (25mm Gap)

Frequency Band	Maximum SAR _{1g} (W/kg)	SAR _{1g} Limit (W/kg)
GSM850	0.007	1.6
GSM1900	0.130	1.6

Extremity SAR

Frequency Band	Extremity SAR(0mm Gap)	SAR _{10g}
	Maximum SAR _{10g} (W/kg)	Limit (W/kg)
GSM850	0.579	4.0
GSM1900	3.319	4.0
Simultaneous Transmission	3.319	4.0

Remark:

*The highest reported SAR values for head, body-worn accessory, wireless router(hotspot), front-of the face, Extremity SAR and simultaneous transmission conditions are **1.073W/kg, 1.113W/kg , 1.281W/kg, 0.130W/kg 3.319W/kg ,and 1.507W/kg** respectively.*

The device is in compliance with Specific Absorption Rate (SAR) for general population/uncontrolled exposure limits (1.6 W/kg) specified in FCC 47 CFR Part 2.1093 and ANSI/IEEE C95.1-2005, and had been tested in accordance with the measurement methods and procedure specified in IEEE 1528-2013 and KDB 865664 D01 v01r04 and KDB 865664 D02 v01r02

3. Specific Absorption Rate (SAR)

3.1 Introduction

SAR is related to the rate at which energy is absorbed per unit mass in an object exposed to a radio field. The SAR distribution in a biological body is complicated and is usually carried out by experimental techniques or numerical modeling. The standard recommends limits for two tiers of groups, occupational/controlled and general population/uncontrolled, based on a person's awareness and ability to exercise control over his or her exposure. In general, occupational/controlled exposure limits are higher than the limits for general population/uncontrolled.

3.2 SAR Definition

The SAR definition is the time derivative (rate) of the incremental energy (dW) absorbed by (dissipated in) an incremental mass (dm) contained in a volume element (dv) of a given density (ρ). The equation description is as below:

$$\text{SAR} = \frac{d}{dt} \left(\frac{dW}{dm} \right) = \frac{d}{dt} \left(\frac{dW}{\rho dv} \right)$$

SAR is expressed in units of Watts per kilogram (W/kg)

SAR measurement can be either related to the temperature elevation in tissue by

$$\text{SAR} = C \left(\frac{\delta T}{\delta t} \right)$$

Where: C is the specific heat capacity, δT is the temperature rise and δt is the exposure duration, or related to the electrical field in the tissue by

$$\text{SAR} = \frac{\sigma |E|^2}{\rho}$$

Where: σ is the conductivity of the tissue, ρ is the mass density of the tissue and E is the RMS electrical field strength.

However for evaluating SAR of low power transmitter, electrical field measurement is typically applied.

4. SAR Measurement System

4.1 The Measurement System

Comosar is a system that is able to determine the SAR distribution inside a phantom of human being according to different standards. The Comosar system consists of the following items:

- Main computer to control all the system
- 6 axis robot
- Data acquisition system
- Miniature E-field probe
- Phone holder
- Head simulating tissue

The following figure shows the system.



The EUT under test operating at the maximum power level is placed in the phone holder, under the phantom, which is filled with head simulating liquid. The E-Field probe measures the electric field inside the phantom. The OpenSAR software computes the results to give a SAR value in a 1g or 10g mass.

4.2 Probe

For the measurements the Specific Dosimetric E-Field Probe SSE5 SN 09/13 EP168 with following specifications is used

- Dynamic range: 0.01-100 W/kg
- Probe Length: 330 mm
- Length of Individual Dipoles: 4.5 mm
- Maximum external diameter: 8 mm
- Probe Tip External Diameter : 5 mm
- Distance between dipoles / probe extremity: 2.7mm

- Probe linearity: <0.25 dB
 - Axial Isotropy: <0.25 dB
 - Spherical Isotropy: <0.50 dB
 - Calibration range: 700 to 3000MHz for head & body simulating liquid.
- Angle between probe axis (evaluation axis) and surface normal line: less than 30°

Probe calibration is realized, in compliance with EN 62209-1 and IEEE 1528 STD, with CALISAR, Antenna proprietary calibration system. The calibration is performed with the EN 62209-1 annexe technique using reference guide at the five frequencies.

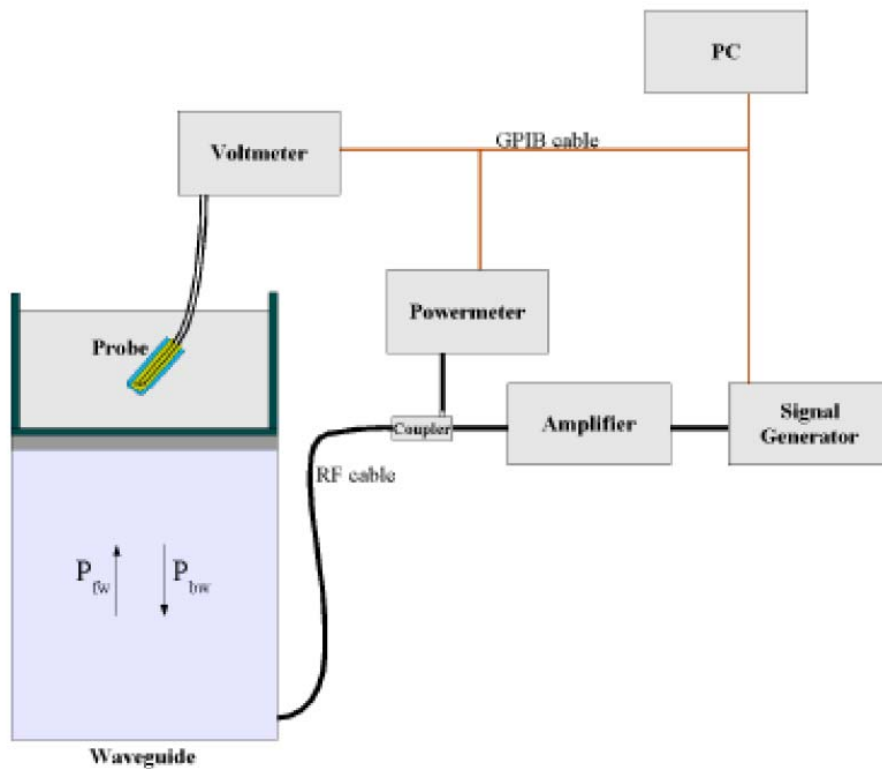

$$SAR = \frac{4(P_{fw} - P_{bw})}{ab\delta} \cos^2\left(\pi \frac{y}{a}\right) e^{-2z/\delta}$$

Where :

P_{fw} = Forward Power

P_{bw} = Backward Power

a and b = Waveguide dimensions

δ = Skin depth

Keithley configuration:

Rate = Medium; Filter = ON; RDGS = 10; Filter type = Moving Average; Range auto after each calibration, a SAR measurement is performed on a validation dipole and compared with a NPL calibrated probe, to verify it.

The calibration factors, CF(N), for the 3 sensors corresponding to dipole 1, dipole 2 and dipole 3 are:

$$CF(N)=SAR(N)/V_{lin}(N) \quad (N=1,2,3)$$

The linearised output voltage $V_{lin}(N)$ is obtained from the displayed output voltage $V(N)$ using

$$V_{lin}(N)=V(N)*(1+V(N)/DCP(N)) \quad (N=1,2,3)$$

where DCP is the diode compression point in mV.

4.3 Probe Calibration Process

Dosimetric Assessment Procedure

Each E-Probe/Probe Amplifier combination has unique calibration parameters. SATIMO Probe calibration procedure is conducted to determine the proper amplifier settings to enter in the probe parameters. The amplifier settings are determined for a given frequency by subjecting the probe to a known E-field density (1 mW/cm²) using an with CALISAR, Antenna proprietary calibration system.

Free Space Assessment Procedure

The free space E-field from amplified probe outputs is determined in a test chamber. This calibration can be performed in a TEM cell if the frequency is below 1 GHz and in a waveguide or other methodologies above 1 GHz for free space. For the free space calibration, the probe is placed in the volumetric center of the cavity and at the proper orientation with the field. The probe is rotated 360 degrees until the three channels show the maximum reading. The power density readings equates to 1mW/cm².

Temperature Assessment Procedure

E-field temperature correlation calibration is performed in a flat phantom filled with the appropriate simulated head tissue. The E-field in the medium correlates with the temperature rise in the dielectric medium. For temperature correlation calibration a RF transparent thermistor-based temperature probe is used in conjunction with the E-field probe.

Where:

$$SAR = C \frac{\Delta T}{\Delta t}$$

Δt = exposure time (30 seconds),

C = heat capacity of tissue (brain or muscle),

ΔT = temperature increase due to RF exposure.

SAR is proportional to $\Delta T/\Delta t$, the initial rate of tissue heating, before thermal diffusion takes place. The electric field in the simulated tissue can be used to estimate SAR by equating the thermally derived SAR to that with the E- field component.

$$\text{SAR} = \frac{|E|^2 \cdot \sigma}{\rho}$$

Where:

σ = simulated tissue conductivity,

ρ = Tissue density (1.25 g/cm³ for brain tissue)

4.4 Phantom

For the measurements the Specific Anthropomorphic Mannequin (SAM) defined by the IEEE SCC-34/SC2 group is used. The phantom is a polyurethane shell integrated in a wooden table. The thickness of the phantom amounts to 2mm +/- 0.2mm. It enables the dosimetric evaluation of left and right phone usage and includes an additional flat phantom part for the simplified performance check. The phantom set-up includes a cover, which prevents the evaporation of the liquid.

4.5 Device Holder

The positioning system allows obtaining cheek and tilting position with a very good accuracy. In compliance with CENELEC, the tilt angle uncertainty is lower than 1°.

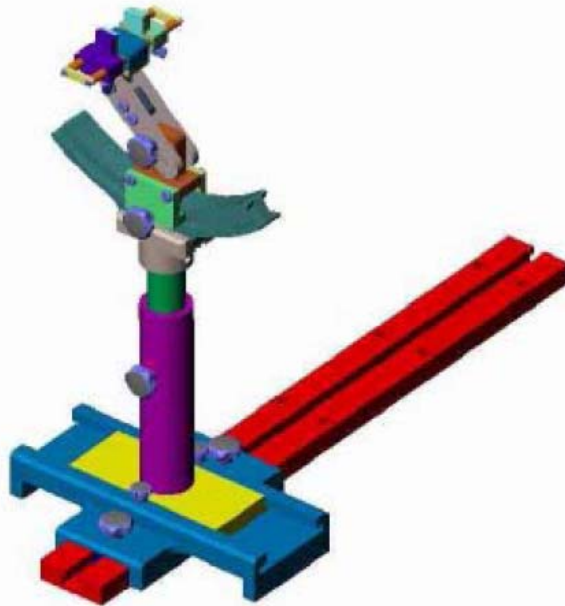

System Material	Permittivity	Loss Tangent
Delrin	3.7	0.005

4.6 Test Equipment List

Description	Manufacturer	Model	Serial Number	Cal. Date	Due. Date
E-Field Probe	MVG	SSE5	SN 09/13 EP168	2019-05-22	2020-05-21
E-Field Probe	MVG	SSE2	SN 45/15 EPGO280	2019-07-08	2020-07-07
750MHz Dipole	MVG	SID750	SN 47/12 DIP 0G750-203	2019-03-16	2020-03-15
835MHz Dipole	MVG	SID835	SN 47/12 DIP 0G835-204	2019-03-16	2020-03-15
1800MHz Dipole	MVG	SID1800	SN 47/12 DIP 1G800-206	2019-03-16	2020-03-15
1900MHz Dipole	MVG	SID1900	SN 47/12 DIP 1G900-207	2019-03-16	2020-03-15
2450MHz Dipole	MVG	SID2450	SN 13/15 DIP 2G450-364	2019-03-16	2020-03-15
2600MHz Dipole	MVG	SID2600	SN 13/15 DIP 2G600-365	2019-03-16	2020-03-15
5 GHz Waveguide	MVG	SWG5500	SN 49/16 WGA45	2019-07-15	2020-07-14
Dielectric Probe Kit	MVG	SCLMP	SN 47/12 OCPG49	2019-03-16	2020-03-15
SAM Phantom	MVG	SAM	SN/ 47/12 SAM95	N/A	N/A
MULTIMETER	KEITHLEY	Keithley 2000	4006367	2019-04-30	2020-04-29
Signal Generator	Rohde & Schwarz	SMR20	100047	2019-04-30	2020-04-29
Universal Tester	Rohde & Schwarz	CMU200	112012	2019-04-30	2020-04-29
Communications Tester	Rohde & Schwarz	CMW500	148650	2019-04-30	2020-04-29
Network Analyzer	HP	8753C	2901A00831	2019-04-30	2020-04-29
Directional Couplers	Agilent	778D	20160	2019-04-30	2020-04-29

5. Tissue Simulating Liquids

5.1 Composition of Tissue Simulating Liquid

For the measurement of the field distribution inside the SAM phantom with SMTIMO, the phantom must be filled with around 25 liters of homogeneous body tissue simulating liquid. For head SAR testing, the liquid height from the ear reference point (ERP) of the phantom to the liquid top surface is larger than 15 cm. For body SAR testing, the liquid height from the center of the flat phantom to the liquid top surface is larger than 15 cm. Please see the following photos for the liquid height.



Liquid Height for Head SAR

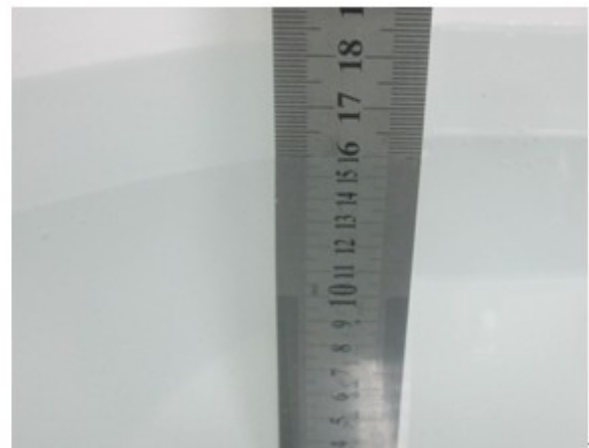

Liquid Height for Body SAR

The Composition of Tissue Simulating Liquid

Frequency (MHz)	Water (%)	Salt (%)	Sugar (%)	HEC (%)	Preventol (%)	DGBE (%)
Head						
750	41.1	1.4	57.0	0.2	0.3	0
835	40.3	1.4	57.9	0.2	0.2	0
1700-1900	55.2	0.3	0	0	0	44.5
2450	55.0	0.1	0	0	0	44.9
2600	54.9	0.1	0	0	0	45.0
Body						
750	50.0	0.8	48.8	0.2	0.2	0
835	50.8	0.9	48.1	0.1	0.1	0
1700-1900	70.2	0.4	0	0	0	29.4
2450	68.6	0.1	0	0	0	31.3
2600	68.2	0.1	0	0	0	31.7

Frequency (MHz)	Water (%)	Hexyl Carbitol (%)	Triton X-100 (%)
Head			
5000-6000	65.52	17.24	17.24
Body			
5000-6000	78.6	10.7	10.7

5.2 Tissue Dielectric Parameters for Head and Body Phantoms

The head tissue dielectric parameters recommended by the IEEE SCC-34/SC-2 in P1528 have been incorporated in the following table. These head parameters are derived from planar layer models simulating the highest expected SAR for the dielectric properties and tissue thickness variations in a human head. Other head and body tissue parameters that have not been specified in P1528 are derived from the tissue dielectric parameters computed from the 4-Cole-Cole equations described in Reference [12] and extrapolated according to the head parameters specified in P1528.

Target Frequency (MHz)	Head		Body	
	Conductivity (σ)	Permittivity (ϵ_r)	Conductivity (σ)	Permittivity (ϵ_r)
150	0.76	52.3	0.80	61.9
300	0.87	45.3	0.92	58.2
450	0.87	43.5	0.94	56.7
750	0.89	41.9	0.96	55.5
835	0.90	41.5	0.97	55.2
900	0.97	41.5	1.05	55.0
915	0.98	41.5	1.06	55.0
1450	1.20	40.5	1.30	54.0
1610	1.29	40.3	1.40	53.8
1750	1.37	40.1	1.49	53.4
1800-2000	1.40	40.0	1.52	53.3
2450	1.80	39.2	1.95	52.7
3000	2.40	38.5	2.73	52.0
5200	4.66	36.0	5.30	49.0
5300	35.9	4.76	5.42	48.9
5600	5.07	35.5	5.77	48.5
5800	5.27	35.3	6.00	48.2

5.3 Tissue Calibration Result

The dielectric parameters of the liquids were verified prior to the SAR evaluation using COMOSAR Dielectric Probe Kit and an Agilent Network Analyzer.

Calibration Result for Dielectric Parameters of Tissue Simulating Liquid

Head Tissue Simulating Liquid									
Freq. MHz.	Temp. (°C)	Conductivity			Permittivity			Limit (%)	Date
		Reading (σ)	Target (σ)	Delta (%)	Reading (ϵ_r)	Target (ϵ_r)	Delta (%)		
750	21.2	0.86	0.89	-3.37	41.32	41.90	-1.38	±5	2019-09-16
835	21.2	0.87	0.90	-3.33	41.11	41.50	-0.94	±5	2019-09-16
1750	21.3	1.37	1.37	0.00	39.02	40.1	-2.69	±5	2019-09-17
1800	21.3	1.37	1.40	-2.14	39.02	40.0	-2.45	±5	2019-09-17
1900	21.3	1.38	1.40	-1.43	38.56	40.00	-3.60	±5	2019-09-17
2450	21.3	1.74	1.80	-3.33	38.15	39.20	-2.68	±5	2019-09-18
2600	21.3	1.93	1.96	-1.53	38.63	39.0	-0.95	±5	2019-09-18
5200	21.3	4.87	4.66	4.51	35.6	36.0	-1.11	±5	2019-09-19
5400	21.3	4.74	4.86	-2.47	35.6	35.8	-0.56	±5	2019-09-19
5600	21.3	5.21	5.07	2.76	35.3	35.5	-0.56	±5	2019-09-19
5800	21.3	5.17	5.27	-1.90	35.6	35.3	0.85	±5	2019-09-19

Body Tissue Simulating Liquid									
Freq. MHz.	Temp. (°C)	Conductivity			Permittivity			Limit (%)	Date
		Reading (σ)	Target (σ)	Delta (%)	Reading (ϵ_r)	Target (ϵ_r)	Delta (%)		
750	21.2	0.93	0.96	-3.12	54.96	55.50	-0.97	±5	2019-09-16
835	21.2	0.95	0.97	-2.06	54.85	55.20	-0.63	±5	2019-09-16
1750	21.3	1.46	1.49	-2.01	51.22	53.40	-4.08	±5	2019-09-17
1800	21.3	1.46	1.52	-3.95	51.22	53.30	-3.90	±5	2019-09-17
1900	21.3	1.50	1.52	-1.32	52.42	53.30	-1.65	±5	2019-09-17
2450	21.3	1.91	1.95	-2.05	52.01	52.70	-1.31	±5	2019-09-18
2600	21.3	2.12	2.16	-1.85	52.24	52.50	-0.50	±5	2019-09-18
5200	21.3	5.16	5.30	-2.64	48.50	49.0	-1.02	±5	2019-09-19
5300	21.3	5.26	5.42	-2.95	48.50	48.9	-0.82	±5	2019-09-19
5600	21.3	5.52	5.77	-4.33	48.30	48.5	-0.41	±5	2019-09-19
5800	21.3	5.76	6.00	-4.00	48.50	48.2	0.62	±5	2019-09-19

6. SAR Measurement Evaluation

6.1 Purpose of System Performance Check

The system performance check verifies that the system operates within its specifications. System and operator errors can be detected and corrected. It is recommended that the system performance check be performed prior to any usage of the system in order to guarantee reproducible results. The system performance check uses normal SAR measurements in a simplified setup with a well characterized source. This setup was selected to give a high sensitivity to all parameters that might fail or vary over time. The system check does not intend to replace the calibration of the components, but indicates situations where the system uncertainty is exceeded due to drift or failure.

6.2 System Setup

In the simplified setup for system evaluation, the EUT is replaced by a calibrated dipole and the power source is replaced by a continuous wave which comes from a signal generator at frequency 835 MHz and 1900 MHz. The calibrated dipole must be placed beneath the flat phantom section of the SAM twin phantom with the correct distance holder. The distance holder should touch the phantom surface with a light pressure at the reference marking and be oriented parallel to the long side of the phantom.

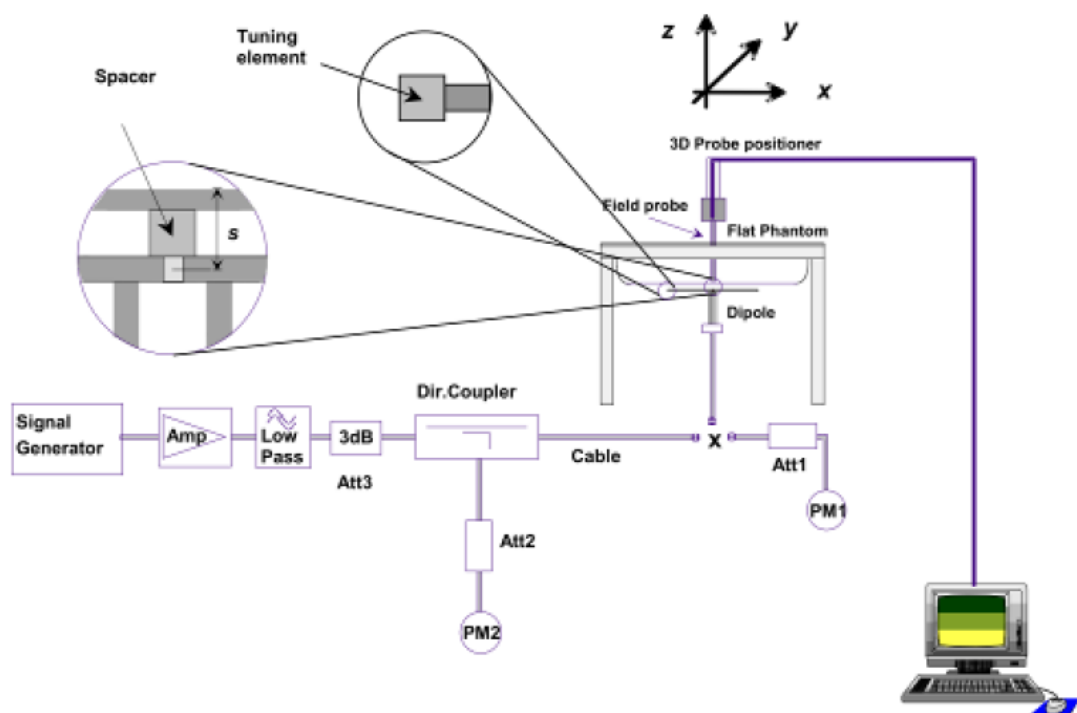

System Verification Setup Block Diagram



Setup Photo of Dipole Antenna

The output power on dipole port must be calibrated to 24 dBm(250 mW) before dipole is connected.
The output power on 5 GHz Waveguide must be calibrated to 20 dBm (100mW) before 5 GHz Waveguide is connected.

6.3 Validation Results

Comparing to the original SAR value provided by SATIMO, the validation data should be within its specification of 10 %. Table 6.1 shows the target SAR and measured SAR after normalized to 1W input power. The table below indicates the system performance check can meet the variation criterion.

Frequency MHz	Targeted SAR _{1g} (W/kg)	Measured SAR _{1g} (W/kg)	Normalized SAR _{1g} (W/kg)	Tolerance (%)	Date
Head					
750	8.40	2.16	8.64	2.86	2019-09-16
835	9.67	2.41	9.64	-0.31	2019-09-16
1800	38.51	9.61	38.44	-0.18	2019-09-17
1900	39.58	9.91	39.64	0.15	2019-09-17
2450	53.69	13.45	53.8	0.20	2019-09-18
2600	55.13	13.67	54.68	-0.82	2019-09-18
Body					
750	8.40	2.12	8.48	0.95	2019-09-16
835	9.38	2.35	9.4	0.21	2019-09-16
1800	38.31	9.58	38.32	0.03	2019-09-17
1900	39.10	9.78	39.12	0.05	2019-09-17
2450	50.41	12.59	50.36	-0.10	2019-09-18

2600	53.89	13.43	53.72	-0.32	2019-09-18
------	-------	-------	-------	-------	------------

Frequency	Liquid	Power (mw)	Targeted SAR1g	Measured SAR1g	Normalized SAR1g	Tolerance
5200	Head	100	161.23	16.946	169.46	5.10
5200	Body	100	154.45	16.681	166.81	8.00
5800	Head	100	179.32	16.946	169.46	-5.50
5800	Body	100	170.71	16.681	166.81	-2.28

Remark: Referring to IEEE 1528-2013, Section 8.2, The system check shall be performed at a test frequency that is within $\pm 10\%$ or ± 100 MHz of the compliance test mid-band frequency, so the 1750 MHz system verification is made of 1800MHz Dipole.

Targeted and Measurement SAR

Please refer to Annex A for the plots of system performance check.

7. EUT Testing Position

7.1 Define Two Imaginary Lines on The Handset

- (a) The vertical centerline passes through two points on the front side of the handset - the midpoint of the width w_t of the handset at the level of the acoustic output, and the midpoint of the width w_b of the bottom of the handset.
- (b) The horizontal line is perpendicular to the vertical centerline and passes through the center of the acoustic output. The horizontal line is also tangential to the face of the handset at point A.
- (c) The two lines intersect at point A. Note that for many handsets, point A coincides with the center of the acoustic output; however, the acoustic output may be located elsewhere on the horizontal line. Also note that the vertical centerline is not necessarily parallel to the front face of the handset, especially for clamshell handsets, handsets with flip covers, and other irregularly shaped handsets.

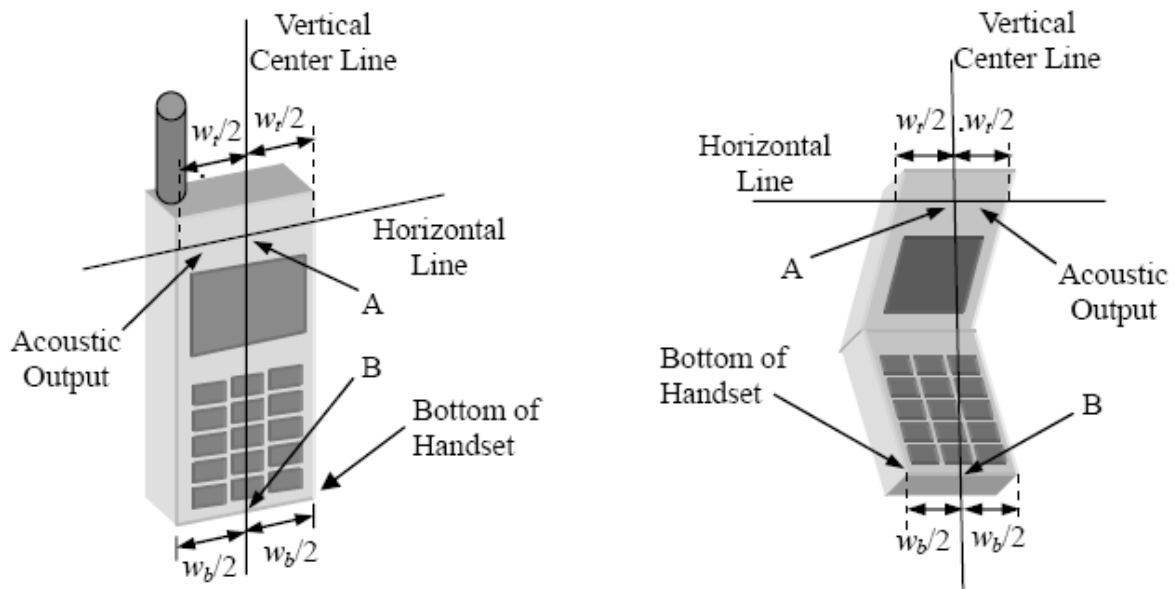

Illustration for Handset Vertical and Horizontal Reference Lines

7.2 Cheek Position

(a) To position the device with the vertical center line of the body of the device and the horizontal line crossing the center piece in a plane parallel to the sagittal plane of the phantom. While maintaining the device in this plane, align the vertical center line with the reference plane containing the three ear and mouth reference point (M: Mouth, RE: Right Ear, and LE: Left Ear) and align the center of the ear piece with the line RE-LE.

(b) To move the device towards the phantom with the ear piece aligned with the line LE-RE until the phone touched the ear. While maintaining the device in the reference plane and maintaining the phone contact with the ear, move the bottom of the phone until any point on the front side is in contact with the cheek of the phantom or until contact with the ear is lost (see Fig. 7.2).

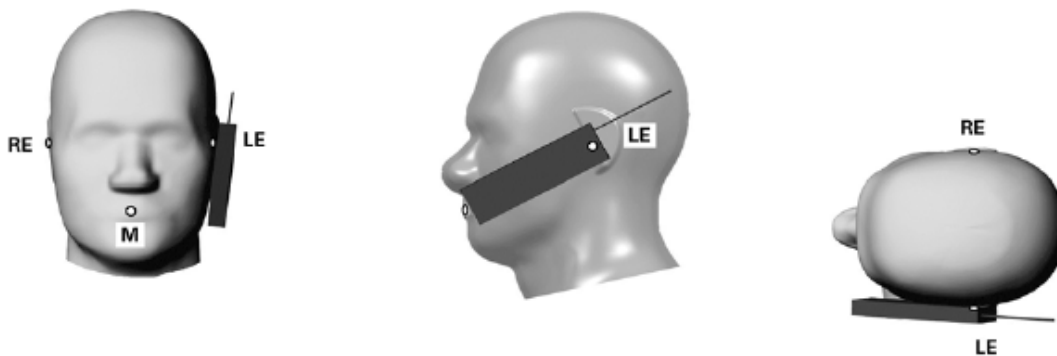

Illustration for Cheek Position

7.3 Tilted Position

(a) To position the device in the “cheek” position described above.

(b) While maintaining the device the reference plane described above and pivoting against the ear, moves it outward away from the mouth by an angle of 15 degrees or until contact with the ear is lost (see Fig. 7.3).

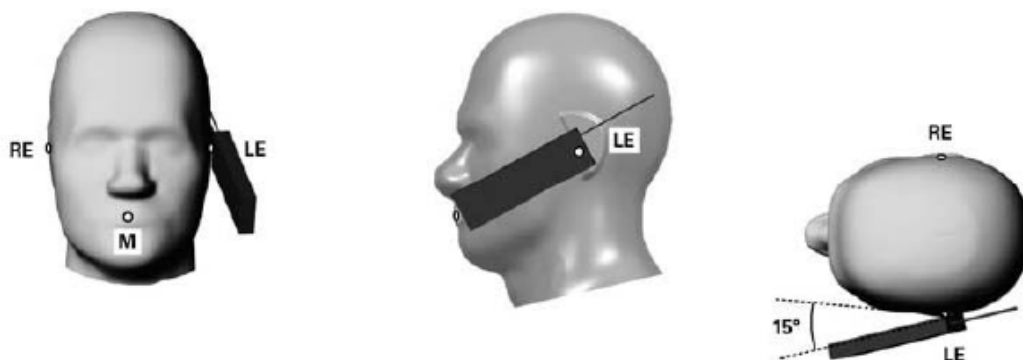

Illustration for Tilted Position

7.4 Body Worn Position

- To position the device parallel to the phantom surface with either keypad up or down.
- To adjust the device parallel to the flat phantom.
- To adjust the distance between the device surface and the flat phantom to 10mm.

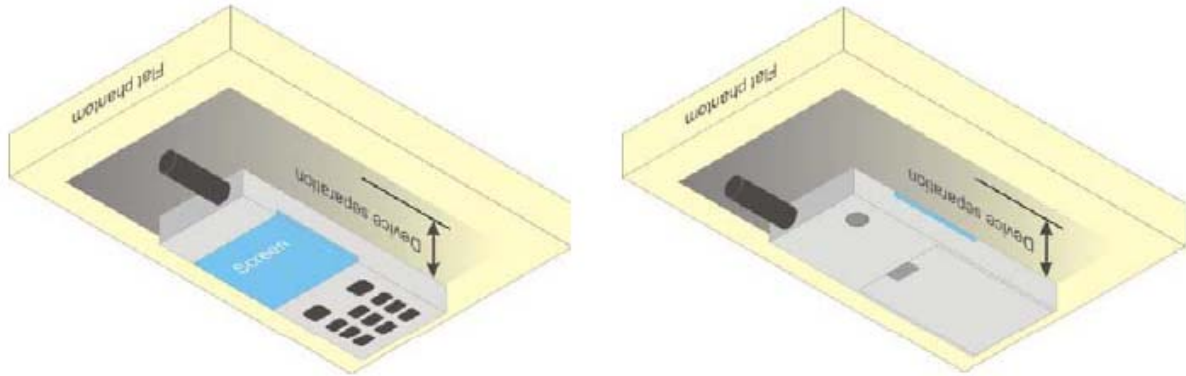
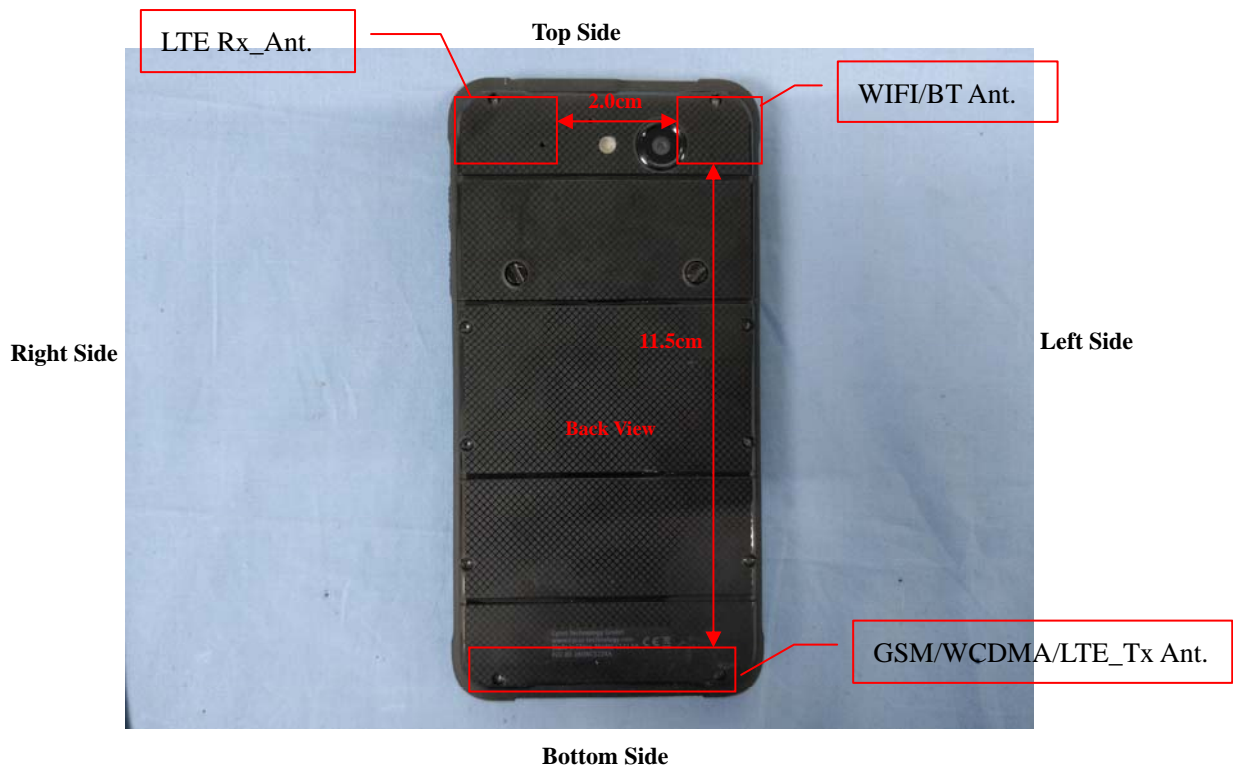

Illustration for Body Worn Position

7.5 EUT Antenna Position





Block Diagram for EUT Antenna Position

7.6 EUT Testing Position

Head/Body-worn/Hotspot mode SAR assessments are required for this device. This EUT was tested in different positions for different SAR test modes, more information as below:

Head SAR tests				
Antennas	Right Cheek	Left Cheek	Right Tilted	Left Tilted
WWAN	Yes	Yes	Yes	Yes
WLAN	Yes	Yes	Yes	Yes

Hotspot SAR tests, Test distance: 10mm						
Antennas	Front	Back	Right Side	Left Side	Top Side	Bottom Side
WWAN	Yes	Yes	Yes	Yes	No	Yes
WLAN	Yes	Yes	No	Yes	Yes	No

Body-worn SAR tests, Test distance: 10mm		
Antennas	Front	Back
WWAN	Yes	Yes
WLAN	Yes	Yes

Front-of the face SAR tests, Test distance: 25mm	
Antennas	Front
WWAN	Yes

Extremity SAR tests, Test distance: 0mm					
Antennas	Front	Back	Bottom	Top	Left
WWAN	No	Yes	No	No	No

Remark:

- Referring to KDB 941225 D06, when the overall device length and width are $\geq 9\text{cm} \times 5\text{cm}$, the test separation distances is 10 mm. SAR must be measured for all sides and surfaces with a transmitting antenna located within 25mm from that surface or edge.
- Referring to KDB 648474 D04 Handset SAR v01r03, 10-g extremity SAR is required only for the surfaces and edges with hotspot mode 1-g reported SAR $> 1.2 \text{ W/kg}$
- The EUT supports PTT function only through GPRS/EDGE network function. With PTT mode, a test separation distance of 25 mm is used for in-front-of the face SAR.

Please refer to Annex D for the EUT test setup photos.

8. SAR Measurement Procedures

8.1 Measurement Procedures

The measurement procedures are as follows:

- (a) Use base station simulator (if applicable) or engineering software to transmit RF power continuously (continuous Tx) in the highest power channel.
- (b) Keep EUT to radiate maximum output power or 100% factor (if applicable)
- (c) Measure output power through RF cable and power meter.
- (d) Place the EUT in the positions as Annex D demonstrates.
- (e) Set scan area, grid size and other setting on the SATIMO software.
- (f) Measure SAR results for the highest power channel on each testing position.
- (g) Find out the largest SAR result on these testing positions of each band
- (h) Measure SAR results for other channels in worst SAR testing position if the SAR of highest power channel is larger than 0.8 W/kg

According to the test standard, the recommended procedure for assessing the peak spatial-average SAR value consists of the following steps:

- (a) Power reference measurement
- (b) Area scan
- (c) Zoom scan
- (d) Power drift measurement

8.2 Spatial Peak SAR Evaluation

The procedure for spatial peak SAR evaluation has been implemented according to the test standard. It can be conducted for 1g and 10g, as well as for user-specific masses. The SATIMO software includes all numerical procedures necessary to evaluate the spatial peak SAR value.

The base for the evaluation is a "cube" measurement. The measured volume must include the 1g and 10g cubes with the highest averaged SAR values. For that purpose, the center of the measured volume is aligned to the interpolated peak SAR value of a previously performed area scan.

The entire evaluation of the spatial peak values is performed within the post-processing engine. The system always gives the maximum values for the 1g and 10g cubes. The algorithm to find the cube with highest averaged SAR is divided into the following stages:

- (a) Extraction of the measured data (grid and values) from the Zoom Scan
- (b) Calculation of the SAR value at every measurement point based on all stored data
- (c) Generation of a high-resolution mesh within the measured volume
- (d) Interpolation of all measured values from the measurement grid to the high-resolution grid
- (e) Extrapolation of the entire 3D field distribution to the phantom surface over the distance from sensor to surface
- (f) Calculation of the averaged SAR within masses of 1g and 10g

8.3 Area & Zoom Scan Procedures

First Area Scan is used to locate the approximate location(s) of the local peak SAR value(s). The measurement grid within an Area Scan is defined by the grid extent, grid step size and grid offset. Next, in order to determine the EM field distribution in a three-dimensional spatial extension, Zoom Scan is required. The Zoom Scan measures 5x5x7 points with step size 8, 8 and 5 mm for 300 MHz to 3 GHz, and 8x8x8 points with step size 4, 4 and 2.5 mm for 3 GHz to 6 GHz. The Zoom Scan is performed around the highest E-field value to determine the averaged SAR-distribution over 10 g.

8.4 Volume Scan Procedures

The volume scan is used for assess overlapping SAR distributions for antennas transmitting in different frequency bands. It is equivalent to an oversized zoom scan used in standalone measurements. The measurement volume will be used to enclose all the simultaneous transmitting antennas. For antennas transmitting simultaneously in different frequency bands, the volume scan is measured separately in each frequency band. In order to sum correctly to compute the 1g aggregate SAR, the EUT remain in the same test position for all measurements and all volume scan use the same spatial resolution and grid spacing (step-size is 4, 4 and 2.5 mm). When all volume scan were completed, the software can combine and subsequently superpose these measurement data to calculating the multiband SAR.

8.5 SAR Averaged Methods

The local SAR inside the phantom is measured using small dipole sensing elements inside a probe body. The probe tip must not be in contact with the phantom surface in order to minimize measurements errors, but the highest local SAR will occur at the surface of the phantom.

An extrapolation is using to determinate this highest local SAR values. The extrapolation is based on a fourth-order least-square polynomial fit of measured data. The local SAR value is then extrapolated from the liquid surface with a 1mm step.

The measurements have to be performed over a limited time (due to the duration of the battery) so the step of measurement is high. It could vary between 5 and 8 mm. To obtain an accurate assessment of the maximum SAR averaged over 10g and 1 g requires a very fine resolution in the three dimensional scanned data array.

8.6 Power Drift Monitoring

All SAR testing is under the EUT install full charged battery and transmit maximum output power. In SATIMO measurement software, the power reference measurement and power drift measurement procedures are used for monitoring the power drift of EUT during SAR test. Both these procedures measure the field at a specified reference position before and after the SAR testing. The software will calculate the field difference in dB. If the power drift more than 5%, the SAR will be retested.

9. SAR Test Result

9.1 Conducted RF Output Power

GSM - Burst Average Power (dBm)								
Band	GSM850			Tune-up power (dBm)	PCS1900			Tune-up power (dBm)
Channel	128	190	251		512	661	810	
Frequency (MHz)	824.2	836.6	848.8		1850.2	1880	1909.8	
GSM	32.64	32.54	32.44	33.0	29.67	29.75	29.9	30.0
GPRS (1 slot)	32.63	32.58	32.45	33.0	29.62	29.81	29.95	30.0
GPRS (2 slots)	32.15	32.07	31.88	32.5	29.18	29.16	29.22	29.5
GPRS (3 slots)	30.64	30.5	30.33	31.0	26.58	26.99	27.25	27.5
GPRS (4 slots)	29.59	29.44	29.57	30.0	25.43	25.95	26.18	26.5
EDGE (1 slot)	26.69	26.65	26.63	27.0	24.53	24.61	24.25	25.0
EDGE (2 slots)	25.35	25.33	25.27	25.5	23.65	23.42	23.07	24.0
EDGE (3 slots)	23.37	23.27	23.23	23.5	21.46	21.33	21.06	21.5
EDGE (4 slots)	22.26	22.19	22.19	22.5	20.4	20.5	20.02	21.0

GSM - Source-Based Time-Average Power (dBm)								
Band	GSM850			Tune-up power (dBm)	PCS1900			Tune-up power (dBm)
Channel	128	190	251		512	661	810	
Frequency (MHz)	824.2	836.6	848.8		1850.2	1880	1909.8	
GSM	23.64	23.54	23.44	24.0	20.67	20.75	20.90	21.0
GPRS (1 slot)	23.63	23.58	23.45	24.0	20.62	20.81	20.95	21.0
GPRS (2 slots)	26.15	26.07	25.88	26.5	23.18	23.16	23.22	23.5
GPRS (3 slots)	26.39	26.25	26.08	26.5	22.33	22.74	23.00	23.5
GPRS (4 slots)	26.59	26.44	26.57	27.5	22.43	22.95	23.18	23.5
EDGE (1 slot)	17.69	17.65	17.63	18.0	15.53	15.61	15.25	16.0
EDGE (2 slots)	19.35	19.33	19.27	20.0	17.65	17.42	17.07	18.0
EDGE (3 slots)	19.12	19.02	18.98	19.5	17.21	17.08	16.81	17.5
EDGE (4 slots)	19.26	19.19	19.19	19.5	17.40	17.50	17.02	18.0

Note: The source-based time-averaged power is linearly scaled the maximum burst averaged power based on time slots. The calculated method are shown as below:

Source based time-average power = Burst averaged power - Duty cycle factor in dB

Duty cycle factor = 9 dB for 1 Tx slot, 6 dB for 2 Tx slots, 4.25 dB for 3 Tx slots, 3 dB for 4 Tx slots

Remark:

- For Head SAR testing, GSM GPRS (4TX slots) and GPRS (2TX slots) should be evaluated, therefore the EUT was set in GSM and GPRS (4TX slots) for GSM850 and GPRS (2TX slots) for GSM1900 due to its highest source-based time-average power.
- For Body SAR testing, GPRS should be evaluated, therefore the EUT was set in GPRS (4TX slots) for GSM850 and

GPRS (2TX slots) for GSM1900 due to its highest source-based time-average power.

3. Per KDB 447498 D01 v06, the maximum output power channel is used for SAR testing and for further SAR test reduction.

4. The DUT do not support DTM function.

5. This device supports VOIP capability through 3rd party apps software.

WCDMA - Average Power (dBm)								
Band	WCDMA Band II				WCDMA Band V			
Channel	9262	9400	9538	Tune-up power (dBm)	4132	4182	4233	Tune-up power (dBm)
Frequency (MHz)	1852.4	1880.0	1907.6		826.4	836.6	846.6	
RMC 12.2k	22.09	22.14	22.29	22.5	22.42	22.45	22.40	22.5
HSDPA Subtest-1	21.06	21.21	21.40	21.5	21.52	21.50	21.47	22.0
HSDPA Subtest-2	21.04	21.18	21.38	21.5	21.50	21.48	21.43	22.0
HSDPA Subtest-3	21.03	21.18	21.37	21.5	21.47	21.49	21.45	21.5
HSDPA Subtest-4	21.04	21.19	21.38	21.5	21.46	21.47	21.45	21.5
HSUPA Subtest-1	21.15	21.22	21.35	21.5	21.67	21.42	21.46	22.0
HSUPA Subtest-2	21.13	21.2	21.32	21.5	21.65	21.4	21.43	22.0
HSUPA Subtest-3	21.14	21.18	21.32	21.5	21.63	21.41	21.45	22.0
HSUPA Subtest-4	21.14	21.18	21.32	21.5	21.64	21.38	21.45	22.0
HSUPA Subtest-5	21.13	21.19	21.33	21.5	21.64	21.38	21.45	22.0

WCDMA - Average Power (dBm)								
Band	WCDMA Band IV							
Channel	1312	1412	1513	Tune-up power (dBm)				
Frequency (MHz)	1712.4	1732.4	1752.6					
RMC 12.2k	21.22	21.27	21.36	21.5				
HSDPA Subtest-1	20.51	20.59	20.45	21.0				
HSDPA Subtest-2	20.48	20.56	20.43	21.0				
HSDPA Subtest-3	20.46	20.57	20.41	21.0				
HSDPA Subtest-4	20.5	20.57	20.43	21.0				
HSUPA Subtest-1	20.47	20.36	20.6	21.0				
HSUPA Subtest-2	20.43	20.32	20.58	21.0				
HSUPA Subtest-3	20.42	20.33	20.59	21.0				
HSUPA Subtest-4	20.45	20.35	20.56	21.0				
HSUPA Subtest-5	20.43	20.34	20.57	21.0				

Remark:

1. For Head SAR, per KDB 941225 D01 v03, RMC 12.2kbps setting is used to evaluate SAR. If AMR 12.2kbps power is < 1/4 dB higher than RMC, SAR tests with AMR 12.2kbps can be excluded.

2. For Body SAR, per KDB 941225 D01 v03, RMC 12.2kbps setting is used to evaluate SAR. If HSDPA subset-1 output power is < 1/4 dB higher than RMC, and SAR with RMC 12.2kbps setting is $\leq 1.2W/kg$, HSDPA SAR evaluation can be excluded

FDD-LTE Band 2:

Channel Bandwidth: 1.4 MHz					
Modulation	Channel	RB Configuration		Average Power [dBm]	MPR (dB)
		Size	Offset		
QPSK	LCH	1	0	22.24	0
		1	3	22.38	0
		1	5	22.22	0
		3	0	21.38	0
		3	2	21.39	0
		3	3	21.40	0
		6	0	21.38	1
	MCH	1	0	21.96	0
		1	3	22.10	0
		1	5	21.98	0
		3	0	21.51	0
		3	2	21.58	0
		3	3	21.57	0
		6	0	21.02	1
	HCH	1	0	21.82	0
		1	3	22.01	0
		1	5	21.83	0
		3	0	21.71	0
		3	2	21.79	0
		3	3	21.74	0
		6	0	20.90	1
16QAM	LCH	1	0	21.52	1
		1	3	21.74	1
		1	5	21.51	1
		3	0	21.52	1
		3	2	21.49	1
		3	3	21.49	1
		6	0	20.30	2
	MCH	1	0	21.36	1
		1	3	21.53	1
		1	5	21.36	1
		3	0	21.06	1
		3	2	21.10	1
		3	3	21.10	1
		6	0	20.96	2
HCH	1	0	21.07	1	
	1	3	21.26	1	

		1	5	21.06	1
		3	0	20.98	1
		3	2	20.98	1
		3	3	20.97	1
		6	0	20.96	2

Channel Bandwidth: 3 MHz					
Modulation	Channel	RB Configuration		Average Power [dBm]	MPR (dB)
		Size	Offset		
QPSK	LCH	1	0	22.26	0
		1	7	22.51	0
		1	14	22.30	0
		8	0	21.30	1
		8	4	21.36	1
		8	7	21.32	1
		15	0	21.29	1
	MCH	1	0	21.98	0
		1	7	22.24	0
		1	14	22.00	0
		8	0	20.99	1
		8	4	21.03	1
		8	7	21.02	1
		15	0	20.93	1
	HCH	1	0	21.87	0
		1	7	22.14	0
		1	14	21.85	0
		8	0	20.86	1
		8	4	20.87	1
		8	7	20.83	1
		15	0	20.82	1
16QAM	LCH	1	0	21.56	1
		1	7	21.84	1
		1	14	21.59	1
		8	0	20.40	2
		8	4	20.41	2
		8	7	20.56	2
		15	0	20.98	2
	MCH	1	0	21.38	1
		1	7	21.68	1
		1	14	21.40	1
		8	0	20.48	2
		8	4	20.69	2
		8	7	20.45	2

	HCH	15	0	20.97	2
		1	0	21.16	1
		1	7	21.42	1
		1	14	21.14	1
		8	0	20.82	2
		8	4	20.86	2
		8	7	20.77	2
		15	0	20.84	2

Channel Bandwidth: 5 MHz					
Modulation	Channel	RB Configuration		Average Power [dBm]	MPR (dB)
		Size	Offset		
QPSK	LCH	1	0	22.33	0
		1	12	22.68	0
		1	24	22.31	0
		12	0	21.29	1
		12	6	21.37	1
		12	13	21.35	1
		25	0	21.34	1
	MCH	1	0	22.03	0
		1	12	22.36	0
		1	24	21.95	0
		12	0	20.95	1
		12	6	21.07	1
		12	13	20.92	1
		25	0	20.97	1
	HCH	1	0	21.89	0
		1	12	22.18	0
		1	24	21.83	0
		12	0	20.89	1
		12	6	20.91	1
		12	13	20.78	1
		25	0	20.88	1
16QAM	LCH	1	0	21.57	1
		1	12	21.75	1
		1	24	21.55	1
		12	0	20.35	2
		12	6	20.44	2
		12	13	20.36	2
		25	0	20.33	2
	MCH	1	0	21.26	1
		1	12	21.54	1
		1	24	21.21	1

		12	0	20.69	2
		12	6	20.87	2
		12	13	20.57	2
		25	0	20.79	2
	HCH	1	0	21.06	1
		1	12	21.47	1
		1	24	21.00	1
		12	0	20.83	2
		12	6	20.89	2
		12	13	20.80	2
		25	0	20.91	2

Channel Bandwidth: 10 MHz					
Modulation	Channel	RB Configuration		Average Power [dBm]	MPR (dB)
		Size	Offset		
QPSK	LCH	1	0	22.32	0
		1	24	22.48	0
		1	49	22.17	0
		25	0	21.30	1
		25	12	21.35	1
		25	25	21.40	1
		50	0	21.36	1
	MCH	1	0	22.03	0
		1	24	22.15	0
		1	49	21.90	0
		25	0	21.05	1
		25	12	21.00	1
		25	25	21.06	1
		50	0	21.05	1
	HCH	1	0	21.81	0
		1	24	22.04	0
		1	49	21.81	0
		25	0	20.96	1
		25	12	20.90	1
		25	25	20.82	1
		50	0	20.86	1
16QAM	LCH	1	0	21.57	1
		1	24	21.77	1
		1	49	21.51	1
		25	0	20.72	2
		25	12	20.58	2
		25	25	20.42	2
		50	0	20.35	2

	MCH	1	0	21.43	1
		1	24	21.59	1
		1	49	21.36	1
		25	0	20.74	2
		25	12	20.97	2
		25	25	20.46	2
		50	0	20.68	2
	HCH	1	0	21.13	1
		1	24	21.33	1
		1	49	21.13	1
		25	0	20.99	2
		25	12	20.92	2
		25	25	20.83	2
		50	0	20.89	2

Channel Bandwidth: 15 MHz					
Modulation	Channel	RB Configuration		Average Power [dBm]	MPR (dB)
		Size	Offset		
QPSK	LCH	1	0	22.25	0
		1	37	22.45	0
		1	74	22.05	0
		37	0	21.29	1
		37	18	21.35	1
		37	38	21.31	1
		75	0	21.33	1
	MCH	1	0	21.99	0
		1	37	22.16	0
		1	74	21.85	0
		37	0	21.14	1
		37	18	21.10	1
		37	38	21.03	1
		75	0	21.10	1
	HCH	1	0	21.91	0
		1	37	22.08	0
		1	74	21.77	0
		37	0	21.01	1
		37	18	20.96	1
		37	38	20.86	1
		75	0	20.92	1
16QAM	LCH	1	0	21.56	1
		1	37	21.75	1
		1	74	21.30	1
		37	0	20.59	2

		37	18	20.78	2
		37	38	20.69	2
		75	0	20.47	2
	MCH	1	0	21.65	1
		1	37	21.42	1
		1	74	21.16	1
		37	0	20.74	2
		37	18	20.39	2
		37	38	20.69	2
		75	0	20.67	2
	HCH	1	0	21.19	1
		1	37	21.26	1
		1	74	21.04	1
		37	0	20.91	2
37		18	20.85	2	
37		38	20.83	2	
75		0	20.91	2	

Channel Bandwidth: 20 MHz					
Modulation	Channel	RB Configuration		Average Power [dBm]	MPR (dB)
		Size	Offset		
QPSK	LCH	1	0	22.37	0
		1	49	22.77	0
		1	99	22.02	0
		50	0	21.88	1
		50	25	21.89	1
		50	50	21.81	1
		100	0	21.85	1
	MCH	1	0	22.04	0
		1	49	22.74	0
		1	99	21.85	0
		50	0	21.12	1
		50	25	21.05	1
		50	50	20.95	1
		100	0	21.01	1
	HCH	1	0	21.79	0
		1	49	22.64	0
		1	99	21.66	0
		50	0	20.89	0.5
		50	25	20.92	0.5
		50	50	20.68	0.5
		100	0	20.79	0.5
16QAM	LCH	1	0	21.52	1

		1	49	21.68	1
		1	99	21.20	1
		50	0	20.87	2
		50	25	20.81	2
		50	50	20.86	2
		100	0	20.95	2
	MCH	1	0	21.38	1
		1	49	21.57	1
		1	99	21.21	1
		50	0	20.51	2
		50	25	20.52	2
		50	50	20.41	2
	HCH	100	0	20.46	2
		1	0	21.13	1
		1	49	21.26	1
		1	99	20.92	1
		50	0	20.92	2
		50	25	20.89	2
		50	50	20.71	2
	100	0	20.84	2	

FDD-LTE Band 4:

Channel Bandwidth: 1.4 MHz						
Modulation	Channel	RB Configuration		Average Power [dBm]	MPR (dB)	
		Size	Offset			
QPSK	LCH	1	0	22.95	0	
		1	3	23.11	0	
		1	5	22.93	0	
		3	0	22.34	0	
		3	2	22.35	0	
		3	3	22.39	0	
		6	0	22.05	1	
	MCH	1	0	22.85	0	
		1	3	22.95	0	
		1	5	22.87	0	
		3	0	22.36	0	
		3	2	22.34	0	
		3	3	22.35	0	
	HCH	6	0	21.86	1	
		1	0	22.78	0	
			1	3	23.03	0

		1	5	22.80	0
		3	0	22.38	0
		3	2	22.36	0
		3	3	22.31	0
		6	0	21.86	1
16QAM	LCH	1	0	22.18	1
		1	3	22.30	1
		1	5	22.07	1
		3	0	22.15	1
		3	2	22.07	1
		3	3	22.06	1
		6	0	21.02	2
	MCH	1	0	22.18	1
		1	3	22.38	1
		1	5	22.28	1
		3	0	21.94	1
		3	2	21.93	1
		3	3	21.93	1
		6	0	21.45	2
	HCH	1	0	22.03	1
		1	3	22.24	1
		1	5	22.08	1
		3	0	21.94	1
		3	2	21.95	1
		3	3	21.93	1
		6	0	21.05	2

Channel Bandwidth: 3 MHz					
Modulation	Channel	RB Configuration		Average Power [dBm]	MPR (dB)
		Size	Offset		
QPSK	LCH	1	0	22.94	0
		1	7	22.98	0
		1	14	22.87	0
		8	0	21.97	1
		8	4	21.95	1
		8	7	21.93	1
		15	0	21.93	1
	MCH	1	0	22.91	0
		1	7	23.14	0
		1	14	22.84	0
		8	0	21.86	1
		8	4	21.91	1
		8	7	21.88	1

	HCH	15	0	21.85	1
		1	0	22.79	0
		1	7	23.09	0
		1	14	22.83	0
		8	0	21.82	1
		8	4	21.84	1
		8	7	21.79	1
		15	0	21.80	1
16QAM	LCH	1	0	22.21	1
		1	7	22.35	1
		1	14	22.11	1
		8	0	21.09	2
		8	4	21.10	2
		8	7	21.02	2
		15	0	20.96	2
	MCH	1	0	22.28	1
		1	7	22.49	1
		1	14	22.26	1
		8	0	20.93	2
		8	4	20.97	2
		8	7	20.93	2
		15	0	20.90	2
	HCH	1	0	22.03	1
		1	7	22.33	1
		1	14	22.09	1
		8	0	20.85	2
		8	4	20.88	2
		8	7	20.80	2
		15	0	20.87	2

Channel Bandwidth: 5 MHz					
Modulation	Channel	RB Configuration		Average Power [dBm]	MPR (dB)
		Size	Offset		
QPSK	LCH	1	0	22.98	0
		1	12	23.20	0
		1	24	22.86	0
		12	0	21.83	1
		12	6	21.96	1
		12	13	21.91	1
		25	0	21.89	1
	MCH	1	0	22.84	0
		1	12	23.17	0
		1	24	22.77	0

		12	0	21.85	1	
		12	6	21.91	1	
		12	13	21.94	1	
		25	0	21.93	1	
	HCH	1	0	22.79	0	
		1	12	23.15	0	
		1	24	22.83	0	
		12	0	21.85	1	
		12	6	21.91	1	
		12	13	21.76	1	
		25	0	21.86	1	
		16QAM	LCH	1	0	22.21
	1			12	22.42	1
1	24			22.09	1	
12	0			20.96	2	
12	6			21.04	2	
12	13			20.98	2	
25	0			20.98	2	
MCH	1		0	22.12	1	
	1		12	22.48	1	
	1		24	22.09	1	
	12		0	21.01	2	
	12		6	21.08	2	
	12		13	21.04	2	
	25		0	20.98	2	
HCH	1	0	21.94	1		
	1	12	22.21	1		
	1	24	22.02	1		
	12	0	20.90	2		
	12	6	20.93	2		
	12	13	20.78	2		
	25	0	20.96	2		

Channel Bandwidth: 10 MHz					
Modulation	Channel	RB Configuration		Average Power [dBm]	MPR (dB)
		Size	Offset		
QPSK	LCH	1	0	22.96	0
		1	24	23.02	0
		1	49	22.83	0
		25	0	21.99	1
		25	12	21.89	1
		25	25	21.89	1
		50	0	21.92	1
	MCH	1	0	22.88	0
		1	24	23.03	0
		1	49	22.78	0
		25	0	21.92	1
		25	12	21.91	1
		25	25	22.04	1
		50	0	21.97	1
	HCH	1	0	22.76	0
		1	24	22.85	0
		1	49	22.79	0
		25	0	21.87	1
		25	12	21.80	1
		25	25	21.76	1
		50	0	21.77	1
16QAM	LCH	1	0	22.20	1
		1	24	22.28	1
		1	49	22.13	1
		25	0	21.00	2
		25	12	20.98	2
		25	25	20.95	2
		50	0	20.97	2
	MCH	1	0	22.31	1
		1	24	22.43	1
		1	49	22.24	1
		25	0	21.04	2
		25	12	21.02	2
		25	25	21.13	2
		50	0	21.12	2
HCH	1	0	21.98	1	
	1	24	22.12	1	
	1	49	22.07	1	
	25	0	20.90	2	

		25	12	20.89	2
		25	25	20.84	2
		50	0	20.87	2

Channel Bandwidth: 15 MHz					
Modulation	Channel	RB Configuration		Average Power [dBm]	MPR (dB)
		Size	Offset		
QPSK	LCH	1	0	22.85	0
		1	37	23.15	0
		1	74	22.80	0
		37	0	22.04	1
		37	18	22.03	1
		37	38	21.84	1
		75	0	21.97	1
	MCH	1	0	22.79	0
		1	37	23.06	0
		1	74	22.69	0
		37	0	21.92	1
		37	18	21.95	1
		37	38	21.98	1
		75	0	21.96	1
	HCH	1	0	22.75	0
		1	37	23.01	0
		1	74	22.73	0
		37	0	21.83	1
		37	18	21.92	1
		37	38	21.76	1
		75	0	21.81	1
16QAM	LCH	1	0	22.08	1
		1	37	22.34	1
		1	74	22.08	1
		37	0	21.00	2
		37	18	21.00	2
		37	38	20.86	2
		75	0	20.96	2
	MCH	1	0	22.15	1
		1	37	22.35	1
		1	74	21.94	1
		37	0	20.95	2
		37	18	21.02	2
		37	38	21.01	2
		75	0	20.97	2
HCH	1	0	21.97	1	

		1	37	22.06	1
		1	74	21.97	1
		37	0	20.79	2
		37	18	20.86	2
		37	38	20.79	2
		75	0	20.85	2

Channel Bandwidth: 20 MHz					
Modulation	Channel	RB Configuration		Average Power [dBm]	MPR (dB)
		Size	Offset		
QPSK	LCH	1	0	22.92	0
		1	49	23.30	0
		1	99	22.79	0
		50	0	22.44	1
		50	25	22.49	1
		50	50	22.48	1
		100	0	22.34	1
	MCH	1	0	22.82	0
		1	49	23.10	0
		1	99	22.70	0
		50	0	21.91	1
		50	25	21.95	1
		50	50	22.06	1
		100	0	22.02	1
	HCH	1	0	22.64	0
		1	49	23.15	0
		1	99	22.58	0
		50	0	21.64	1
		50	25	21.80	1
		50	50	21.66	1
		100	0	21.59	1
16QAM	LCH	1	0	22.06	1
		1	49	22.26	1
		1	99	22.00	1
		50	0	21.06	2
		50	25	20.99	2
		50	50	20.85	2
		100	0	20.98	2
	MCH	1	0	22.14	1
		1	49	22.49	1
		1	99	22.01	1
		50	0	21.04	2
		50	25	21.07	2

		50	50	21.14	2
		100	0	21.08	2
	HCH	1	0	22.02	1
		1	49	22.16	1
		1	99	21.91	1
		50	0	20.67	2
		50	25	20.86	2
		50	50	20.69	2
		100	0	20.68	2

FDD-LTE Band 5:

Channel Bandwidth: 1.4 MHz					
Modulation	Channel	RB Configuration		Average Power [dBm]	MPR (dB)
		Size	Offset		
QPSK	LCH	1	0	22.77	0
		1	3	22.93	0
		1	5	22.81	0
		3	0	22.34	0
		3	2	22.37	0
		3	3	22.34	0
		6	0	21.78	1
	MCH	1	0	22.84	0
		1	3	23.03	0
		1	5	22.91	0
		3	0	22.34	0
		3	2	22.33	0
		3	3	22.32	0
		6	0	21.84	1
	HCH	1	0	23.03	0
		1	3	23.17	0
		1	5	23.04	0
		3	0	22.14	0
		3	2	22.19	0
		3	3	22.16	0
		6	0	22.07	1
16QAM	LCH	1	0	22.06	1
		1	3	22.22	1
		1	5	22.05	1
		3	0	22.01	1
		3	2	21.99	1
		3	3	21.93	1
		6	0	20.78	2
	MCH	1	0	22.31	1
		1	3	22.44	1
		1	5	22.28	1
		3	0	21.95	1
		3	2	21.99	1
		3	3	21.97	1
		6	0	20.84	2
	HCH	1	0	22.33	1
		1	3	22.43	1
		1	5	22.36	1

		3	0	22.19	1
		3	2	22.21	1
		3	3	22.22	1
		6	0	21.14	2

Channel Bandwidth: 3 MHz					
Modulation	Channel	RB Configuration		Average Power [dBm]	MPR (dB)
		Size	Offset		
QPSK	LCH	1	0	22.75	0
		1	7	23.06	0
		1	14	22.83	0
		8	0	21.77	1
		8	4	21.82	1
		8	7	21.79	1
		15	0	21.77	1
	MCH	1	0	22.87	0
		1	7	23.10	0
		1	14	22.83	0
		8	0	21.85	1
		8	4	21.89	1
		8	7	21.83	1
		15	0	21.79	1
	HCH	1	0	23.08	0
		1	7	23.17	0
		1	14	23.08	0
		8	0	22.00	1
		8	4	22.06	1
		8	7	21.98	1
		15	0	22.04	1
16QAM	LCH	1	0	22.06	1
		1	7	22.34	1
		1	14	22.18	1
		8	0	20.86	2
		8	4	20.93	2
		8	7	20.86	2
		15	0	20.77	2
	MCH	1	0	22.38	1
		1	7	22.47	1
		1	14	22.30	1
		8	0	20.90	2
		8	4	20.89	2
		8	7	20.85	2
		15	0	20.84	2

HCH	1	0	22.41	1
	1	7	22.48	1
	1	14	22.39	1
	8	0	20.98	2
	8	4	21.06	2
	8	7	21.01	2
	15	0	21.03	2

Channel Bandwidth: 5 MHz					
Modulation	Channel	RB Configuration		Average Power [dBm]	MPR (dB)
		Size	Offset		
QPSK	LCH	1	0	22.73	0
		1	12	22.95	0
		1	24	22.83	0
		12	0	21.74	1
		12	6	21.88	1
		12	13	21.81	1
		25	0	21.81	1
	MCH	1	0	22.80	0
		1	12	22.91	0
		1	24	22.79	0
		12	0	21.87	1
		12	6	21.91	1
		12	13	21.82	1
		25	0	21.85	1
	HCH	1	0	22.97	0
		1	12	23.39	0
		1	24	23.06	0
		12	0	21.97	1
		12	6	22.05	1
		12	13	21.92	1
		25	0	22.00	1
16QAM	LCH	1	0	22.08	1
		1	12	22.40	1
		1	24	22.09	1
		12	0	20.89	2
		12	6	20.94	2
		12	13	20.91	2
		25	0	20.86	2
	MCH	1	0	22.09	1
		1	12	22.47	1
		1	24	22.11	1
		12	0	20.98	2

		12	6	21.04	2
		12	13	21.01	2
		25	0	20.89	2
	HCH	1	0	22.22	1
		1	12	22.39	1
		1	24	22.20	1
		12	0	20.96	2
		12	6	21.05	2
		12	13	20.95	2
		25	0	21.06	2

Channel Bandwidth: 10 MHz					
Modulation	Channel	RB Configuration		Average Power [dBm]	MPR (dB)
		Size	Offset		
QPSK	LCH	1	0	22.80	0
		1	24	23.45	0
		1	49	22.85	0
		25	0	22.44	1
		25	12	22.46	1
		25	25	22.36	1
		50	0	22.31	1
	MCH	1	0	22.86	0
		1	24	23.35	0
		1	49	22.87	0
		25	0	21.93	1
		25	12	21.91	1
		25	25	21.89	1
		50	0	21.82	1
	HCH	1	0	22.92	0
		1	24	23.38	0
		1	49	23.07	0
		25	0	22.06	1
		25	12	22.05	1
		25	25	22.07	1
		50	0	22.05	1
16QAM	LCH	1	0	22.15	1
		1	24	22.33	1
		1	49	22.16	1
		25	0	20.99	2
		25	12	20.91	2
		25	25	20.97	2
		50	0	20.92	2
	MCH	1	0	22.37	1

		1	24	22.42	1
		1	49	22.35	1
		25	0	20.97	2
		25	12	20.99	2
		25	25	20.94	2
		50	0	20.96	2
	HCH	1	0	22.27	1
		1	24	22.31	1
		1	49	22.41	1
		25	0	21.14	2
		25	12	21.06	2
		25	25	21.13	2
		50	0	21.15	2

FDD-LTE Band 7:

Channel Bandwidth: 5 MHz					
Modulation	Channel	RB Configuration		Average Power [dBm]	MPR (dB)
		Size	Offset		
QPSK	LCH	1	0	22.01	0
		1	12	22.34	0
		1	24	22.00	0
		12	0	21.03	1
		12	6	21.07	1
		12	13	21.00	1
		25	0	21.01	1
	MCH	1	0	22.20	0
		1	12	22.57	0
		1	24	22.28	0
		12	0	21.20	1
		12	6	21.31	1
		12	13	21.23	1
		25	0	21.25	1
	HCH	1	0	22.79	0
		1	12	23.16	0
		1	24	22.88	0
		12	0	21.91	1
		12	6	21.92	1
		12	13	21.83	1
		25	0	21.87	1
16QAM	LCH	1	0	21.24	1
		1	12	21.51	1
		1	24	21.24	1
		12	0	21.04	2
		12	6	21.12	2
		12	13	21.13	2
		25	0	21.04	2
	MCH	1	0	21.53	1
		1	12	21.67	1
		1	24	21.50	1
		12	0	20.36	2
		12	6	20.41	2
		12	13	20.35	2
		25	0	20.81	2
	HCH	1	0	21.94	1
		1	12	22.32	1
		1	24	22.00	1

		12	0	20.90	2
		12	6	20.89	2
		12	13	20.78	2
		25	0	20.88	2

Channel Bandwidth: 10 MHz					
Modulation	Channel	RB Configuration		Average Power [dBm]	MPR (dB)
		Size	Offset		
QPSK	LCH	1	0	22.02	0
		1	24	22.17	0
		1	49	22.01	0
		25	0	21.05	1
		25	12	21.08	1
		25	25	21.11	1
		50	0	21.07	1
	MCH	1	0	22.22	0
		1	24	22.44	0
		1	49	22.39	0
		25	0	21.41	1
		25	12	21.34	1
		25	25	21.40	1
		50	0	21.37	1
	HCH	1	0	22.73	0
		1	24	22.96	0
		1	49	22.91	0
		25	0	21.96	1
		25	12	21.82	1
		25	25	21.76	1
		50	0	21.85	1
16QAM	LCH	1	0	21.32	1
		1	24	21.37	1
		1	49	21.27	1
		25	0	21.10	2
		25	12	21.08	2
		25	25	21.12	2
		50	0	21.11	2
	MCH	1	0	21.64	1
		1	24	21.88	1
		1	49	21.76	1
		25	0	20.41	2
		25	12	20.78	2
		25	25	20.48	2
		50	0	20.42	2

	HCH	1	0	21.96	1
		1	24	22.18	1
		1	49	22.08	1
		25	0	20.94	2
		25	12	20.82	2
		25	25	20.77	2
		50	0	20.85	2

Channel Bandwidth: 15 MHz					
Modulation	Channel	RB Configuration		Average Power [dBm]	MPR (dB)
		Size	Offset		
QPSK	LCH	1	0	21.96	0
		1	37	22.28	0
		1	74	21.91	0
		37	0	21.07	1
		37	18	21.12	1
		37	38	21.06	1
		75	0	21.04	1
	MCH	1	0	22.12	0
		1	37	22.45	0
		1	74	22.30	0
		37	0	21.32	1
		37	18	21.40	1
		37	38	21.39	1
		75	0	21.37	1
	HCH	1	0	22.61	0
		1	37	23.00	0
		1	74	22.80	0
		37	0	21.82	1
		37	18	21.83	1
		37	38	21.76	1
		75	0	21.80	1
16QAM	LCH	1	0	21.25	1
		1	37	21.47	1
		1	74	21.18	1
		37	0	21.02	2
		37	18	21.06	2
		37	38	21.05	2
		75	0	21.05	2
	MCH	1	0	21.47	1
		1	37	21.80	1
		1	74	21.58	1
		37	0	20.72	2

		37	18	20.40	2
		37	38	20.69	2
		75	0	20.49	2
	HCH	1	0	21.86	1
		1	37	22.21	1
		1	74	22.00	1
		37	0	20.69	2
		37	18	20.80	2
		37	38	20.70	2
		75	0	20.76	2

Channel Bandwidth: 20 MHz					
Modulation	Channel	RB Configuration		Average Power [dBm]	MPR (dB)
		Size	Offset		
QPSK	LCH	1	0	22.99	0
		1	49	23.17	0
		1	99	22.99	0
		50	0	21.01	1
		50	25	21.06	1
		50	50	21.03	1
		100	0	20.98	1
	MCH	1	0	22.10	0
		1	49	23.25	0
		1	99	22.40	0
		50	0	21.31	1
		50	25	21.36	1
		50	50	21.35	1
		100	0	21.32	1
	HCH	1	0	22.38	0
		1	49	23.28	0
		1	99	22.66	0
		50	0	21.97	1
		50	25	21.99	1
		50	50	21.89	1
		100	0	21.58	1
16QAM	LCH	1	0	21.16	1
		1	49	21.43	1
		1	99	21.16	1
		50	0	20.99	2
		50	25	21.02	2
		50	50	21.04	2
		100	0	20.98	2
	MCH	1	0	21.46	1

		1	49	21.90	1
		1	99	21.73	1
		50	0	20.78	2
		50	25	20.46	2
		50	50	20.98	2
		100	0	20.35	2
	HCH	1	0	21.70	1
		1	49	22.09	1
		1	99	21.93	1
		50	0	20.70	2
		50	25	20.79	2
		50	50	20.56	2
		100	0	20.60	2

FDD-LTE Band 12:

Channel Bandwidth: 1.4 MHz					
Modulation	Channel	RB Configuration		Average Power [dBm]	MPR (dB)
		Size	Offset		
QPSK	LCH	1	0	22.69	0
		1	3	22.72	0
		1	5	22.65	0
		3	0	21.65	0
		3	2	21.72	0
		3	3	21.69	0
		6	0	21.58	1
	MCH	1	0	22.56	0
		1	3	22.60	0
		1	5	22.49	0
		3	0	21.58	0
		3	2	21.61	0
		3	3	21.60	0
		6	0	21.48	1
	HCH	1	0	22.50	0
		1	3	22.55	0
		1	5	22.52	0
		3	0	21.59	0
		3	2	21.58	0
		3	3	21.58	0
		6	0	21.49	1
16QAM	LCH	1	0	21.89	1
		1	3	21.91	1
		1	5	21.95	1
		3	0	21.72	1
		3	2	21.77	1
		3	3	21.79	1
		6	0	20.71	2
	MCH	1	0	21.73	1
		1	3	21.96	1
		1	5	21.76	1
		3	0	21.74	1
		3	2	21.74	1
		3	3	21.72	1
		6	0	20.72	2
	HCH	1	0	21.83	1
		1	3	21.88	1
		1	5	21.93	1

		3	0	21.57	1
		3	2	21.64	1
		3	3	21.63	1
		6	0	20.48	2

Channel Bandwidth: 3 MHz					
Modulation	Channel	RB Configuration		Average Power [dBm]	MPR (dB)
		Size	Offset		
QPSK	LCH	1	0	22.49	0
		1	7	22.82	0
		1	14	22.57	0
		8	0	21.55	1
		8	4	21.61	1
		8	7	21.54	1
		15	0	21.56	1
	MCH	1	0	22.57	0
		1	7	22.74	0
		1	14	22.56	0
		8	0	21.52	1
		8	4	21.56	1
		8	7	21.52	1
		15	0	21.63	1
	HCH	1	0	22.72	0
		1	7	22.80	0
		1	14	22.55	0
		8	0	21.53	1
		8	4	21.49	1
		8	7	21.47	1
		15	0	21.43	1
16QAM	LCH	1	0	21.84	1
		1	7	21.84	1
		1	14	21.90	1
		8	0	20.68	2
		8	4	20.72	2
		8	7	20.61	2
		15	0	20.56	2
	MCH	1	0	21.73	1
		1	7	21.77	1
		1	14	21.96	1
		8	0	20.54	2
		8	4	20.54	2
		8	7	20.63	2
		15	0	20.53	2

	HCH	1	0	21.89	1
		1	7	21.86	1
		1	14	21.84	1
		8	0	20.44	2
		8	4	20.51	2
		8	7	20.46	2
		15	0	20.50	2

Channel Bandwidth: 5 MHz					
Modulation	Channel	RB Configuration		Average Power [dBm]	MPR (dB)
		Size	Offset		
QPSK	LCH	1	0	22.54	0
		1	12	22.83	0
		1	24	22.57	0
		12	0	21.70	1
		12	6	21.65	1
		12	13	21.58	1
		25	0	21.67	1
	MCH	1	0	22.48	0
		1	12	22.89	0
		1	24	22.49	0
		12	0	21.46	1
		12	6	21.57	1
		12	13	21.64	1
		25	0	21.59	1
	HCH	1	0	22.53	0
		1	12	22.86	0
		1	24	22.54	0
		12	0	21.57	1
		12	6	21.64	1
		12	13	21.44	1
		25	0	21.51	1
16QAM	LCH	1	0	21.86	1
		1	12	21.71	1
		1	24	21.86	1
		12	0	20.79	2
		12	6	20.70	2
		12	13	20.70	2
		25	0	20.71	2
	MCH	1	0	21.80	1
		1	12	21.79	1
		1	24	21.77	1
		12	0	20.59	2

		12	6	20.68	2
		12	13	20.72	2
		25	0	20.63	2
	HCH	1	0	21.74	1
		1	12	21.61	1
		1	24	21.76	1
		12	0	20.69	2
		12	6	20.89	2
		12	13	20.41	2
		25	0	20.60	2

Channel Bandwidth: 10 MHz					
Modulation	Channel	RB Configuration		Average Power [dBm]	MPR (dB)
		Size	Offset		
QPSK	LCH	1	0	22.53	0
		1	24	22.87	0
		1	49	22.47	0
		25	0	21.75	1
		25	12	21.58	1
		25	25	21.79	1
		50	0	21.75	1
	MCH	1	0	22.59	0
		1	24	22.91	0
		1	49	22.49	0
		25	0	21.85	1
		25	12	21.85	1
		25	25	21.78	1
		50	0	21.60	1
	HCH	1	0	22.57	0
		1	24	22.89	0
		1	49	22.53	0
		25	0	21.42	1
		25	12	21.54	1
		25	25	21.52	1
		50	0	21.49	1
16QAM	LCH	1	0	21.90	1
		1	24	21.86	1
		1	49	21.80	1
		25	0	20.82	2
		25	12	20.63	2
		25	25	20.82	2
		50	0	20.78	2
	MCH	1	0	21.95	1

		1	24	21.85	1
		1	49	21.96	1
		25	0	20.62	2
		25	12	20.64	2
		25	25	20.76	2
		50	0	20.64	2
	HCH	1	0	21.86	1
		1	24	22.00	1
		1	49	21.81	1
		25	0	20.52	2
		25	12	20.81	2
		25	25	20.75	2
		50	0	20.61	2

FDD-LTE Band 13:

Channel Bandwidth: 5 MHz					
Modulation	Channel	RB Configuration		Average Power [dBm]	MPR (dB)
		Size	Offset		
QPSK	LCH	1	0	23.67	0
		1	12	23.98	0
		1	24	23.73	0
		12	0	22.72	1
		12	6	22.79	1
		12	13	22.90	1
		25	0	22.81	1
	MCH	1	0	23.71	0
		1	12	24.07	0
		1	24	23.70	0
		12	0	22.67	1
		12	6	22.83	1
		12	13	22.81	1
		25	0	22.78	1
	HCH	1	0	23.78	0
		1	12	24.09	0
		1	24	23.75	0
		12	0	22.77	1
		12	6	22.82	1
		12	13	22.70	1
		25	0	22.75	1
16QAM	LCH	1	0	22.86	1
		1	12	23.13	1
		1	24	22.98	1
		12	0	21.71	2
		12	6	21.77	2
		12	13	21.92	2
		25	0	21.83	2
	MCH	1	0	22.87	1
		1	12	23.37	1
		1	24	22.96	1
		12	0	21.75	2
		12	6	21.95	2
		12	13	21.91	2
		25	0	21.79	2
	HCH	1	0	22.94	1
		1	12	23.26	1
		1	24	22.87	1

		12	0	21.71	2
		12	6	21.80	2
		12	13	21.66	2
		25	0	21.76	2

Channel Bandwidth: 10 MHz					
Modulation	Channel	RB Configuration		Average Power [dBm]	MPR (dB)
		Size	Offset		
QPSK	LCH	/	/	/	/
		/	/	/	/
		/	/	/	/
		/	/	/	/
		/	/	/	/
		/	/	/	/
		/	/	/	/
	MCH	1	0	23.70	0
		1	24	24.11	0
		1	49	23.70	0
		25	0	23.15	1
		25	12	23.17	1
		25	25	23.11	1
		50	0	23.14	1
	HCH	/	/	/	/
		/	/	/	/
		/	/	/	/
		/	/	/	/
		/	/	/	/
		/	/	/	/
		/	/	/	/
16QAM	LCH	/	/	/	/
		/	/	/	/
		/	/	/	/
		/	/	/	/
		/	/	/	/
		/	/	/	/
		/	/	/	/
	MCH	1	0	22.90	1
		1	24	23.18	1
		1	49	22.99	1
		25	0	21.77	2
		25	12	21.83	2
		25	25	21.80	2
		50	0	21.73	2

		/	/	/	/
		/	/	/	/
		/	/	/	/
	HCH	/	/	/	/
		/	/	/	/
		/	/	/	/
		/	/	/	/

FDD-LTE Band 17:

Channel Bandwidth: 5 MHz					
Modulation	Channel	RB Configuration		Average Power [dBm]	MPR (dB)
		Size	Offset		
QPSK	LCH	1	0	22.56	0
		1	12	23.29	0
		1	24	22.50	0
		12	0	21.55	1
		12	6	21.70	1
		12	13	21.73	1
		25	0	21.65	1
	MCH	1	0	22.56	0
		1	12	23.24	0
		1	24	22.53	0
		12	0	21.53	1
		12	6	21.81	1
		12	13	21.69	1
		25	0	22.03	1
	HCH	1	0	23.04	0
		1	12	23.34	0
		1	24	22.63	0
		12	0	22.12	1
		12	6	22.19	1
		12	13	22.14	1
		25	0	22.17	1
16QAM	LCH	1	0	21.84	1
		1	12	22.19	1
		1	24	21.82	1
		12	0	20.56	2
		12	6	20.71	2
		12	13	20.72	2
		25	0	20.68	2
	MCH	1	0	21.82	1
		1	12	22.16	1
		1	24	21.76	1
		12	0	21.01	2
		12	6	21.16	2
		12	13	21.08	2
		25	0	21.04	2
HCH	1	0	21.82	1	
	1	12	22.07	1	

		1	24	21.75	1
		12	0	20.66	2
		12	6	20.84	2
		12	13	20.70	2
		25	0	20.75	2

Channel Bandwidth: 10 MHz					
Modulation	Channel	RB Configuration		Average Power [dBm]	MPR (dB)
		Size	Offset		
QPSK	LCH	1	0	22.57	0
		1	24	22.73	0
		1	49	22.54	0
		25	0	21.53	1
		25	12	21.67	1
		25	25	21.59	1
		50	0	21.99	1
	MCH	1	0	22.56	0
		1	24	22.72	0
		1	49	22.61	0
		25	0	21.53	1
		25	12	21.66	1
		25	25	21.57	1
		50	0	21.86	1
	HCH	1	0	22.80	0
		1	24	22.74	0
		1	49	22.66	0
		25	0	21.54	1
		25	12	21.68	1
		25	25	21.72	1
		50	0	21.87	1
16QAM	LCH	1	0	21.86	1
		1	24	22.03	1
		1	49	21.87	1
		25	0	20.64	2
		25	12	20.90	2
		25	25	21.05	2
		50	0	21.00	2
	MCH	1	0	22.00	1
		1	24	22.15	1
		1	49	21.96	1
		25	0	20.91	2
		25	12	21.11	2
		25	25	21.00	2

		50	0	20.82	2
	HCH	1	0	21.89	1
		1	24	22.04	1
		1	49	21.88	1
		25	0	20.85	2
		25	12	21.10	2
		25	25	20.97	2
		50	0	20.85	2

FDD-LTE Band 25:

Channel Bandwidth: 1.4 MHz					
Modulation	Channel	RB Configuration		Average Power [dBm]	MPR (dB)
		Size	Offset		
QPSK	LCH	1	0	22.04	0
		1	3	22.14	0
		1	5	22.01	0
		3	0	21.12	0
		3	2	21.14	0
		3	3	21.11	0
		6	0	21.09	1
	MCH	1	0	21.63	0
		1	3	21.78	0
		1	5	21.63	0
		3	0	21.12	0
		3	2	21.11	0
		3	3	21.12	0
		6	0	20.66	1
	HCH	1	0	21.48	0
		1	3	21.62	0
		1	5	21.47	0
		3	0	21.14	0
		3	2	21.18	0
		3	3	21.19	0
		6	0	21.21	1
16QAM	LCH	1	0	21.25	1
		1	3	21.43	1
		1	5	21.31	1
		3	0	21.23	1
		3	2	21.25	1
		3	3	21.20	1
		6	0	20.36	2
	MCH	1	0	20.98	1
		1	3	21.18	1
		1	5	21.04	1
		3	0	20.70	1
		3	2	20.73	1
		3	3	20.73	1
		6	0	20.47	2
HCH	1	0	20.68	1	
	1	3	20.88	1	

		1	5	20.66	1
		3	0	20.51	1
		3	2	20.60	1
		3	3	20.56	1
		6	0	20.41	2

Channel Bandwidth: 3 MHz					
Modulation	Channel	RB Configuration		Average Power [dBm]	MPR (dB)
		Size	Offset		
QPSK	LCH	1	0	22.02	0
		1	7	22.24	0
		1	14	21.96	0
		8	0	21.06	1
		8	4	21.07	1
		8	7	21.04	1
		15	0	21.04	1
	MCH	1	0	21.71	0
		1	7	21.86	0
		1	14	21.61	0
		8	0	20.63	1
		8	4	20.63	1
		8	7	20.62	1
		15	0	20.61	1
	HCH	1	0	21.54	0
		1	7	21.59	0
		1	14	21.52	0
		8	0	20.40	1
		8	4	20.46	1
		8	7	20.44	1
		15	0	20.33	1
16QAM	LCH	1	0	21.36	1
		1	7	21.45	1
		1	14	21.29	1
		8	0	20.42	2
		8	4	20.45	2
		8	7	20.48	2
		15	0	20.39	2
	MCH	1	0	21.06	1
		1	7	21.28	1
		1	14	21.05	1
		8	0	20.34	2
		8	4	20.35	2
		8	7	20.37	2

	HCH	15	0	20.36	2
		1	0	20.83	1
		1	7	20.88	1
		1	14	20.72	1
		8	0	20.30	2
		8	4	20.32	2
		8	7	20.39	2
		15	0	20.38	2

Channel Bandwidth: 5 MHz					
Modulation	Channel	RB Configuration		Average Power [dBm]	MPR (dB)
		Size	Offset		
QPSK	LCH	1	0	22.05	0
		1	12	22.32	0
		1	24	21.99	0
		12	0	20.97	1
		12	6	21.07	1
		12	13	21.04	1
		25	0	21.01	1
	MCH	1	0	21.72	0
		1	12	21.91	0
		1	24	21.64	0
		12	0	20.63	1
		12	6	20.68	1
		12	13	20.68	1
		25	0	20.69	1
	HCH	1	0	21.51	0
		1	12	21.90	0
		1	24	21.52	0
		12	0	20.64	1
		12	6	20.44	1
		12	13	20.75	1
		25	0	20.67	1
16QAM	LCH	1	0	21.32	1
		1	12	21.49	1
		1	24	21.21	1
		12	0	20.44	2
		12	6	20.43	2
		12	13	20.48	2
		25	0	20.46	2
	MCH	1	0	20.98	1
		1	12	21.17	1
		1	24	20.90	1

		12	0	20.45	2
		12	6	20.39	2
		12	13	20.37	2
		25	0	20.32	2
	HCH	1	0	20.68	1
		1	12	20.94	1
		1	24	20.66	1
		12	0	20.42	2
		12	6	20.43	2
		12	13	20.43	2
		25	0	20.42	2

Channel Bandwidth: 10 MHz					
Modulation	Channel	RB Configuration		Average Power [dBm]	MPR (dB)
		Size	Offset		
QPSK	LCH	1	0	22.06	0
		1	24	22.48	0
		1	49	21.88	0
		25	0	21.00	1
		25	12	21.28	1
		25	25	21.15	1
		50	0	21.00	1
	MCH	1	0	21.86	0
		1	24	22.38	0
		1	49	21.83	0
		25	0	20.70	1
		25	12	20.69	1
		25	25	20.71	1
		50	0	20.70	1
	HCH	1	0	21.84	0
		1	24	22.36	0
		1	49	21.81	0
		25	0	20.72	1
		25	12	20.66	1
		25	25	20.97	1
		50	0	20.73	1
16QAM	LCH	1	0	21.28	1
		1	24	21.46	1
		1	49	21.20	1
		25	0	20.38	2
		25	12	20.37	2
		25	25	20.46	2
		50	0	20.34	2
	MCH	1	0	21.07	1
		1	24	21.22	1
		1	49	20.99	1
		25	0	20.33	2
		25	12	20.37	2
		25	25	20.33	2
		50	0	20.37	2
HCH	1	0	20.71	1	
	1	24	20.76	1	
	1	49	20.43	1	
	25	0	20.34	2	

		25	12	20.39	2
		25	25	20.40	2
		50	0	20.39	2

Channel Bandwidth: 15 MHz					
Modulation	Channel	RB Configuration		Average Power [dBm]	MPR (dB)
		Size	Offset		
QPSK	LCH	1	0	21.93	0
		1	37	21.95	0
		1	74	21.70	0
		37	0	21.02	1
		37	18	21.06	1
		37	38	21.01	1
		75	0	21.01	1
	MCH	1	0	21.66	0
		1	37	21.83	0
		1	74	21.54	0
		37	0	20.71	1
		37	18	20.78	1
		37	38	20.71	1
		75	0	20.74	1
	HCH	1	0	21.52	0
		1	37	21.72	0
		1	74	21.42	0
		37	0	20.42	1
		37	18	20.35	1
		37	38	20.33	1
		75	0	20.33	1
16QAM	LCH	1	0	21.24	1
		1	37	21.35	1
		1	74	20.98	1
		37	0	20.36	2
		37	18	20.32	2
		37	38	20.35	2
		75	0	20.33	2
	MCH	1	0	20.96	1
		1	37	21.18	1
		1	74	20.81	1
		37	0	20.35	2
		37	18	20.33	2
		37	38	20.34	2
		75	0	20.37	2
HCH	1	0	20.74	1	

		1	37	20.94	1
		1	74	20.44	1
		37	0	20.39	2
		37	18	20.46	2
		37	38	20.50	2
		75	0	20.30	2

Channel Bandwidth: 20 MHz					
Modulation	Channel	RB Configuration		Average Power [dBm]	MPR (dB)
		Size	Offset		
QPSK	LCH	1	0	22.04	0
		1	49	22.12	0
		1	99	21.60	0
		50	0	20.87	1
		50	25	20.93	1
		50	50	20.85	1
		100	0	20.80	1
	MCH	1	0	21.68	0
		1	49	21.90	0
		1	99	21.50	0
		50	0	20.69	1
		50	25	20.71	1
		50	50	20.63	1
		100	0	20.65	1
	HCH	1	0	21.42	0
		1	49	21.60	0
		1	99	21.32	0
		50	0	20.50	1
		50	25	20.55	1
		50	50	20.38	1
		100	0	20.55	1
16QAM	LCH	1	0	21.12	1
		1	49	21.29	1
		1	99	20.92	1
		50	0	20.38	2
		50	25	20.34	2
		50	50	20.35	2
		100	0	20.37	2
	MCH	1	0	21.04	1
		1	49	21.24	1
		1	99	20.86	1
		50	0	20.32	2
		50	25	20.37	2

		50	50	20.32	2
		100	0	20.38	2
	HCH	1	0	20.69	1
		1	49	20.94	1
		1	99	20.59	1
		50	0	20.39	2
		50	25	20.32	2
		50	50	20.36	2
		100	0	20.35	2

TDD-LTE Band 26(814-824MHz):

Channel Bandwidth: 1.4 MHz					
Modulation	Channel	RB Configuration		Average Power [dBm]	MPR (dB)
		Size	Offset		
QPSK	LCH	1	0	22.83	0
		1	3	22.98	0
		1	5	22.81	0
		3	0	22.19	1
		3	2	22.14	1
		3	3	22.19	1
		6	0	21.87	1
	MCH	1	0	22.79	0
		1	3	22.96	0
		1	5	22.85	0
		3	0	22.17	1
		3	2	22.13	1
		3	3	22.15	1
		6	0	21.88	1
	HCH	1	0	22.87	0
		1	3	23.01	0
		1	5	22.89	0
		3	0	22.08	1
		3	2	22.01	1
		3	3	22.04	1
		6	0	21.92	1
16QAM	LCH	1	0	22.05	1
		1	3	22.23	1
		1	5	22.10	1
		3	0	22.03	2
		3	2	22.02	2
		3	3	22.01	2
		6	0	20.84	2
	MCH	1	0	22.28	1
		1	3	22.42	1
		1	5	22.30	1
		3	0	21.96	2
		3	2	21.99	2
		3	3	21.98	2
		6	0	20.84	2
	HCH	1	0	22.21	1
1		3	22.35	1	

		1	5	22.22	1
		3	0	22.04	2
		3	2	22.06	2
		3	3	22.09	2
		6	0	21.06	2

Channel Bandwidth: 3 MHz					
Modulation	Channel	RB Configuration		Average Power [dBm]	MPR (dB)
		Size	Offset		
QPSK	LCH	1	0	22.84	0
		1	7	23.13	0
		1	14	22.91	0
		8	0	21.92	1
		8	4	21.94	1
		8	7	21.91	1
		15	0	21.88	1
	MCH	1	0	22.90	0
		1	7	23.15	0
		1	14	22.90	0
		8	0	21.84	1
		8	4	21.95	1
		8	7	21.90	1
		15	0	21.84	1
	HCH	1	0	22.96	0
		1	7	23.33	0
		1	14	22.93	0
		8	0	21.89	1
		8	4	21.93	1
		8	7	21.89	1
		15	0	21.86	1
16QAM	LCH	1	0	22.14	1
		1	7	22.46	1
		1	14	22.24	1
		8	0	20.97	2
		8	4	21.03	2
		8	7	20.97	2
		15	0	20.87	2
	MCH	1	0	22.35	1
		1	7	22.47	1
		1	14	22.36	1
		8	0	20.90	2
		8	4	20.91	2

		8	7	20.93	2
		15	0	20.87	2
	HCH	1	0	22.29	1
		1	7	22.40	1
		1	14	22.22	1
		8	0	20.88	2
		8	4	20.94	2
		8	7	20.87	2
		15	0	20.93	2

Channel Bandwidth: 5 MHz					
Modulation	Channel	RB Configuration		Average Power [dBm]	MPR (dB)
		Size	Offset		
QPSK	LCH	1	0	22.84	0
		1	12	23.26	0
		1	24	22.85	0
		12	0	21.90	1
		12	6	22.01	1
		12	13	21.91	1
		25	0	21.97	1
	MCH	1	0	22.86	0
		1	12	23.21	0
		1	24	22.84	0
		12	0	21.86	1
		12	6	21.96	1
		12	13	21.93	1
		25	0	21.95	1
	HCH	1	0	22.94	0
		1	12	23.27	0
		1	24	22.89	0
		12	0	21.82	1
		12	6	22.00	1
		12	13	21.89	1
		25	0	21.92	1
16QAM	LCH	1	0	22.10	1
		1	12	22.52	1
		1	24	22.14	1
		12	0	20.95	2
		12	6	21.05	2
		12	13	21.02	2
		25	0	21.04	2
	MCH	1	0	22.17	1
		1	12	22.57	1

		1	24	22.16	1
		12	0	21.01	2
		12	6	21.11	2
		12	13	21.07	2
		25	0	21.01	2
	HCH	1	0	22.10	1
		1	12	22.46	1
		1	24	22.07	1
		12	0	20.84	2
		12	6	20.99	2
		12	13	20.92	2
		25	0	21.00	2

Channel Bandwidth: 10 MHz					
Modulation	Channel	RB Configuration		Average Power [dBm]	MPR (dB)
		Size	Offset		
QPSK	LCH	1	0	/	0
		1	24	/	0
		1	49	/	0
		25	0	/	1
		25	12	/	1
		25	25	/	1
		50	0	/	1
	MCH	1	0	22.86	0
		1	24	23.41	0
		1	49	22.85	0
		25	0	22.17	1
		25	12	22.21	1
		25	25	22.16	1
		50	0	22.19	1
	HCH	1	0	/	0
		1	24	/	0
		1	49	/	0
		25	0	/	1
		25	12	/	1
		25	25	/	1
		50	0	/	1
16QAM	LCH	1	0	/	1
		1	24	/	1
		1	49	/	1
		25	0	/	2
		25	12	/	2
		25	25	/	2

		50	0	/	2
	MCH	1	0	22.12	1
		1	24	22.37	1
		1	49	22.15	1
		25	0	20.96	2
		25	12	21.00	2
		25	25	21.05	2
		50	0	20.94	2
	HCH	1	0	/	1
		1	24	/	1
		1	49	/	1
		25	0	/	2
		25	12	/	2
		25	25	/	2
		50	0	/	2

TDD-LTE Band 26(824-849MHz):

Channel Bandwidth: 1.4 MHz					
Modulation	Channel	RB Configuration		Average Power [dBm]	MPR (dB)
		Size	Offset		
QPSK	LCH	1	0	22.67	0
		1	3	22.80	0
		1	5	22.74	0
		3	0	22.59	1
		3	2	22.53	1
		3	3	22.59	1
		6	0	21.70	1
	MCH	1	0	22.85	0
		1	3	22.97	0
		1	5	22.90	0
		3	0	22.57	1
		3	2	22.55	1
		3	3	22.58	1
		6	0	21.88	1
	HCH	1	0	23.05	0
		1	3	23.24	0
		1	5	23.13	0
		3	0	22.20	1
		3	2	22.23	1
		3	3	22.23	1
		6	0	22.14	1
16QAM	LCH	1	0	21.99	1
		1	3	22.16	1
		1	5	22.02	1
		3	0	21.94	2
		3	2	21.96	2
		3	3	21.91	2
		6	0	20.72	2
	MCH	1	0	22.27	1
		1	3	22.43	1
		1	5	22.33	1
		3	0	21.97	2
		3	2	22.01	2
		3	3	21.99	2
		6	0	20.83	2
	HCH	1	0	22.32	1
		1	3	22.58	1
		1	5	22.43	1

		3	0	22.25	2
		3	2	22.26	2
		3	3	22.30	2
		6	0	21.27	2

Channel Bandwidth: 3 MHz					
Modulation	Channel	RB Configuration		Average Power [dBm]	MPR (dB)
		Size	Offset		
QPSK	LCH	1	0	22.74	0
		1	7	22.92	0
		1	14	22.80	0
		8	0	21.76	1
		8	4	21.82	1
		8	7	21.77	1
		15	0	21.73	1
	MCH	1	0	22.94	0
		1	7	23.21	0
		1	14	22.90	0
		8	0	21.88	1
		8	4	21.95	1
		8	7	21.89	1
		15	0	21.86	1
	HCH	1	0	23.12	0
		1	7	23.37	0
		1	14	23.16	0
		8	0	22.10	1
		8	4	22.14	1
		8	7	22.07	1
		15	0	22.13	1
16QAM	LCH	1	0	22.10	1
		1	7	22.42	1
		1	14	22.13	1
		8	0	20.87	2
		8	4	20.94	2
		8	7	20.86	2
		15	0	20.71	2
	MCH	1	0	22.35	1
		1	7	22.55	1
		1	14	22.39	1
		8	0	20.96	2
		8	4	20.94	2
		8	7	20.92	2

	HCH	15	0	20.95	2
		1	0	22.54	1
		1	7	22.69	1
		1	14	22.46	1
		8	0	21.02	2
		8	4	21.13	2
		8	7	21.07	2
		15	0	21.13	2

Channel Bandwidth: 5 MHz					
Modulation	Channel	RB Configuration		Average Power [dBm]	MPR (dB)
		Size	Offset		
QPSK	LCH	1	0	22.71	0
		1	12	23.10	0
		1	24	22.79	0
		12	0	21.79	1
		12	6	21.86	1
		12	13	21.82	1
		25	0	21.80	1
	MCH	1	0	22.85	0
		1	12	23.29	0
		1	24	22.84	0
		12	0	21.89	1
		12	6	21.98	1
		12	13	21.92	1
		25	0	21.91	1
	HCH	1	0	23.08	0
		1	12	23.51	0
		1	24	23.16	0
		12	0	22.05	1
		12	6	22.16	1
		12	13	22.08	1
		25	0	22.09	1
16QAM	LCH	1	0	22.04	1
		1	12	22.39	1
		1	24	22.11	1
		12	0	20.84	2
		12	6	20.91	2
		12	13	20.88	2
		25	0	20.88	2
	MCH	1	0	22.20	1
		1	12	22.31	1
		1	24	22.20	1

		12	0	21.01	2
		12	6	21.10	2
		12	13	21.00	2
		25	0	20.99	2
	HCH	1	0	22.26	1
		1	12	22.69	1
		1	24	22.31	1
		12	0	21.05	2
		12	6	21.17	2
		12	13	21.00	2
		25	0	21.15	2

Channel Bandwidth: 10 MHz					
Modulation	Channel	RB Configuration		Average Power [dBm]	MPR (dB)
		Size	Offset		
QPSK	LCH	1	0	22.77	0
		1	24	23.57	0
		1	49	22.87	0
		25	0	21.96	1
		25	12	21.93	1
		25	25	21.96	1
		50	0	21.96	1
	MCH	1	0	22.94	0
		1	24	23.59	0
		1	49	22.95	0
		25	0	22.65	1
		25	12	22.61	1
		25	25	22.67	1
		50	0	22.63	1
	HCH	1	0	23.07	0
		1	24	23.55	0
		1	49	23.14	0
		25	0	22.18	1
		25	12	22.13	1
		25	25	22.19	1
		50	0	22.13	1
16QAM	LCH	1	0	22.10	1
		1	24	22.35	1
		1	49	22.25	1
		25	0	21.01	2
		25	12	20.94	2
		25	25	21.01	2
		50	0	20.94	2

	MCH	1	0	22.38	1
		1	24	22.55	1
		1	49	22.43	1
		25	0	21.03	2
		25	12	21.03	2
		25	25	21.05	2
		50	0	20.99	2
	HCH	1	0	22.37	1
		1	24	22.58	1
		1	49	22.49	1
		25	0	21.22	2
		25	12	21.15	2
		25	25	21.23	2
		50	0	21.20	2

TDD-LTE Band 30:

Channel Bandwidth: 5 MHz					
Modulation	Channel	RB Configuration		Average Power [dBm]	MPR (dB)
		Size	Offset		
QPSK	LCH	1	0	23.52	0
		1	12	23.88	0
		1	24	23.55	0
		12	0	22.53	1
		12	6	22.62	1
		12	13	22.57	1
		25	0	22.53	1
	MCH	1	0	23.65	0
		1	12	23.95	0
		1	24	23.54	0
		12	0	22.64	1
		12	6	22.65	1
		12	13	22.62	1
		25	0	22.52	1
	HCH	1	0	23.58	0
		1	12	23.88	0
		1	24	23.42	0
		12	0	22.42	1
		12	6	22.46	1
		12	13	22.39	1
		25	0	22.39	1
16QAM	LCH	1	0	22.73	1
		1	12	22.96	1
		1	24	22.60	1
		12	0	21.55	2
		12	6	21.62	2
		12	13	21.57	2
		25	0	21.55	2
	MCH	1	0	22.80	1
		1	12	22.85	1
		1	24	22.68	1
		12	0	21.53	2
		12	6	21.53	2
		12	13	21.46	2
		25	0	21.38	2
	HCH	1	0	22.66	1
		1	12	22.90	1
		1	24	22.50	1

		12	0	21.36	2
		12	6	21.37	2
		12	13	21.30	2
		25	0	21.37	2

Channel Bandwidth: 10 MHz					
Modulation	Channel	RB Configuration		Average Power [dBm]	MPR (dB)
		Size	Offset		
QPSK	LCH	1	0	/	0
		1	24	/	0
		1	49	/	0
		25	0	/	1
		25	12	/	1
		25	25	/	1
		50	0	/	1
	MCH	1	0	23.89	0
		1	24	23.65	0
		1	49	23.40	0
		25	0	22.49	1
		25	12	22.48	1
		25	25	22.44	1
		50	0	22.40	1
	HCH	1	0	/	0
		1	24	/	0
		1	49	/	0
		25	0	/	1
		25	12	/	1
		25	25	/	1
		50	0	/	1
16QAM	LCH	1	0	/	1
		1	24	/	1
		1	49	/	1
		25	0	/	2
		25	12	/	2
		25	25	/	2
		50	0	/	2
	MCH	1	0	22.75	1
		1	24	22.72	1
		1	49	22.51	1
		25	0	21.46	2
		25	12	21.43	2
		25	25	21.39	2
		50	0	21.40	2

		1	0	/	1
		1	24	/	1
		1	49	/	1
	HCH	25	0	/	2
		25	12	/	2
		25	25	/	2
		50	0	/	2

FDD-LTE Band 40: 2305-2315MHz

Channel Bandwidth: 5 MHz					
Modulation	Channel	RB Configuration		Average Power [dBm]	MPR (dBm)
		Size	Offset		
QPSK	LCH	1	0	22.52	0
		1	12	22.81	0
		1	24	22.50	0
		12	0	21.23	1
		12	6	21.30	1
		12	13	21.25	1
		25	0	21.23	1
	HCH	1	0	22.31	0
		1	12	22.57	0
		1	24	22.20	0
		12	0	21.21	1
		12	6	21.20	1
		12	13	21.13	1
		25	0	21.10	1
16QAM	LCH	1	0	21.54	1
		1	12	21.62	1
		1	24	21.28	1
		12	0	20.61	2
		12	6	20.62	2
		12	13	20.67	2
		25	0	20.63	2
	HCH	1	0	21.45	1
		1	12	21.66	1
		1	24	21.30	1
		12	0	20.66	2
		12	6	20.66	2
		12	13	20.61	2
		25	0	20.65	2

Channel Bandwidth: 10 MHz					
Modulation	Channel	RB Configuration		Average Power [dBm]	MPR (dBm)
		Size	Offset		
QPSK	MCH	1	0	22.86	0
		1	24	22.41	0
		1	49	22.21	0
		25	0	21.39	1
		25	12	21.35	1
		25	25	21.36	1
		50	0	21.38	1
16QAM	MCH	1	0	21.54	1
		1	24	21.46	1
		1	49	21.31	1
		25	0	20.59	2
		25	12	20.57	2
		25	25	20.57	2
		50	0	20.59	2

FDD-LTE Band 40: 2350-2360MHz

Channel Bandwidth: 5 MHz					
Modulation	Channel	RB Configuration		Average Power [dBm]	MPR (dBm)
		Size	Offset		
QPSK	LCH	1	0	22.86	0
		1	12	22.86	0
		1	24	22.81	0
		12	0	21.90	1
		12	6	21.88	1
		12	13	21.85	1
		25	0	21.86	1
	HCH	1	0	22.87	0
		1	12	22.85	0
		1	24	22.79	0
		12	0	21.79	1
		12	6	21.87	1
		12	13	21.84	1
		25	0	21.80	1
16QAM	LCH	1	0	21.75	1
		1	12	21.79	1
		1	24	21.96	1
		12	0	20.92	2
		12	6	20.92	2

		12	13	20.89	2
		25	0	20.85	2
	HCH	1	0	21.87	1
		1	12	21.85	1
		1	24	22.00	1
		12	0	20.78	2
		12	6	20.82	2
		12	13	20.80	2
		25	0	20.82	2

Channel Bandwidth: 10 MHz					
Modulation	Channel	RB Configuration		Average Power [dBm]	MPR (dBm)
		Size	Offset		
QPSK	MCH	1	0	22.94	0
		1	24	22.97	0
		1	49	22.77	0
		25	0	21.91	1
		25	12	21.89	1
		25	25	21.91	1
		50	0	21.90	1
16QAM	MCH	1	0	21.83	1
		1	24	21.86	1
		1	49	22.00	1
		25	0	20.88	2
		25	12	20.89	2
		25	25	20.92	2
		50	0	20.90	2

FDD-LTE Band 66:

Channel Bandwidth: 1.4 MHz					
Modulation	Channel	RB Configuration		Average Power [dBm]	MPR (dB)
		Size	Offset		
QPSK	LCH	1	0	25.19	0
		1	3	25.07	0
		1	5	24.72	0
		3	0	24.39	0
		3	2	24.31	0
		3	3	24.39	0
		6	0	23.79	1
	MCH	1	0	24.69	0
		1	3	24.66	0
		1	5	24.4	0
		3	0	24.26	0
		3	2	24.35	0
		3	3	24.26	0
		6	0	23.46	1
	HCH	1	0	24.73	0
		1	3	24.75	0
		1	5	24.58	0
		3	0	24.39	0
		3	2	24.33	0
		3	3	24.23	0
		6	0	23.63	1
16QAM	LCH	1	0	24.18	1
		1	3	24.16	1
		1	5	23.92	1
		3	0	23.87	1
		3	2	23.87	1
		3	3	23.85	1
		6	0	22.74	2
	MCH	1	0		1
		1	3		1
		1	5		1
		3	0		1
		3	2		1
		3	3	23.48	1
		6	0	22.45	2
	HCH	1	0	23.78	1
		1	3	24.01	1
		1	5	23.83	1

		3	0	23.72	1
		3	2	23.72	1
		3	3	23.70	1
		6	0	22.78	2

Channel Bandwidth: 3 MHz					
Modulation	Channel	RB Configuration		Average Power [dBm]	MPR (dB)
		Size	Offset		
QPSK	LCH	1	0	22.78	0
		1	7	25.22	0
		1	14	25.21	0
		8	0	24.18	1
		8	4	24.07	1
		8	7	24.10	1
		15	0	24.06	1
	MCH	1	0	24.01	0
		1	7	24.80	0
		1	14	24.76	0
		8	0	24.12	1
		8	4	23.57	1
		8	7	23.75	1
		15	0	23.69	1
	HCH	1	0	23.69	0
		1	7	25.02	0
		1	14	24.56	0
		8	0	24.19	1
		8	4	23.63	1
		8	7	23.69	1
		15	0	23.63	1
16QAM	LCH	1	0	23.57	1
		1	7	24.42	1
		1	14	24.42	1
		8	0	23.46	2
		8	4	22.90	2
		8	7	23.07	2
		15	0	22.94	2
	MCH	1	0	22.79	1
		1	7	24.06	1
		1	14	23.66	1
		8	0	22.70	2
		8	4	22.59	2
		8	7	22.82	2
		15	0	22.82	2

	HCH	1	0	22.71	1
		1	7	23.95	1
		1	14	23.93	1
		8	0	22.96	2
		8	4	22.71	2
		8	7	22.71	2
		15	0	22.65	2

Channel Bandwidth: 5 MHz					
Modulation	Channel	RB Configuration		Average Power [dBm]	MPR (dB)
		Size	Offset		
QPSK	LCH	1	0	24.63	0
		1	12	25.17	0
		1	24	25.47	0
		12	0	24.42	1
		12	6	23.94	1
		12	13	24.22	1
		25	0	24.00	1
	MCH	1	0	23.83	0
		1	12	24.96	0
		1	24	25.37	0
		12	0	24.41	1
		12	6	23.50	1
		12	13	23.75	1
		25	0	23.59	1
	HCH	1	0	23.82	0
		1	12	24.98	0
		1	24	25.39	0
		12	0	24.41	1
		12	6	23.61	1
		12	13	23.67	1
		25	0	23.54	1
16QAM	LCH	1	0	23.58	1
		1	12	24.32	1
		1	24	24.47	1
		12	0	23.35	2
		12	6	23.30	2
		12	13	23.28	2
		25	0	22.97	2
	MCH	1	0	22.92	1
		1	12	23.92	1
		1	24	24.00	1
		12	0	23.38	2

		12	6	22.67	2
		12	13	22.84	2
		25	0	22.72	2
	HCH	1	0	22.79	1
		1	12	23.83	1
		1	24	24.07	1
		12	0	23.13	2
		12	6	22.76	2
		12	13	22.80	2
		25	0	22.65	2

Channel Bandwidth: 10 MHz					
Modulation	Channel	RB Configuration		Average Power [dBm]	MPR (dB)
		Size	Offset		
QPSK	LCH	1	0	23.67	0
		1	24	24.75	0
		1	49	24.86	0
		25	0	24.13	1
		25	12	23.89	1
		25	25	23.79	1
		50	0	23.70	1
	MCH	1	0	23.79	0
		1	24	24.65	0
		1	49	24.74	0
		25	0	24.42	1
		25	12	23.62	1
		25	25	23.68	1
		50	0	23.57	1
	HCH	1	0	23.77	0
		1	24	25.01	0
		1	49	24.66	0
		25	0	24.11	1
		25	12	23.70	1
		25	25	23.57	1
		50	0	23.45	1
16QAM	LCH	1	0	23.62	1
		1	24	24.11	1
		1	49	24.27	1
		25	0	23.04	2
		25	12	22.97	2
		25	25	22.83	2
		50	0	22.79	2
	MCH	1	0	22.90	1

		1	24	23.76	1
		1	49	23.84	1
		25	0	23.27	2
		25	12	22.65	2
		25	25	22.71	2
		50	0	22.59	2
	HCH	1	0	22.76	1
		1	24	23.82	1
		1	49	23.92	1
		25	0	23.25	2
		25	12	22.75	2
		25	25	22.64	2
		50	0	22.53	2

Channel Bandwidth: 15 MHz					
Modulation	Channel	RB Configuration		Average Power [dBm]	MPR (dB)
		Size	Offset		
QPSK	LCH	1	0	23.61	0
		1	37	25.26	0
		1	74	25.20	0
		37	0	24.25	1
		37	18	23.94	1
		37	38	23.94	1
		75	0	23.75	1
	MCH	1	0	23.90	0
		1	37	24.56	0
		1	74	24.54	0
		37	0	24.39	1
		37	18	23.73	1
		37	38	23.67	1
		75	0	23.51	1
	HCH	1	0	23.61	0
		1	37	24.63	0
		1	74	24.64	0
		37	0	24.37	1
		37	18	23.63	1
		37	38	23.69	1
		75	0	23.62	1
16QAM	LCH	1	0	23.60	1
		1	37	24.46	1
		1	74	24.50	1
		37	0	23.32	2
		37	18	22.97	2

		37	38	22.91	2
		75	0	22.85	2
	MCH	1	0	22.91	1
		1	37	23.77	1
		1	74	23.75	1
		37	0	23.34	2
		37	18	22.70	2
		37	38	22.64	2
		75	0	22.49	2
	HCH	1	0	22.63	1
		1	37	23.83	1
		1	74	23.85	1
		37	0	23.37	2
		37	18	22.62	2
37		38	22.75	2	
		75	0	22.62	2

Channel Bandwidth: 20 MHz					
Modulation	Channel	RB Configuration		Average Power [dBm]	MPR (dB)
		Size	Offset		
QPSK	LCH	1	0	23.63	0
		1	49	24.80	0
		1	99	25.00	0
		50	0	23.73	1
		50	25	23.98	1
		50	50	23.76	1
		100	0	23.75	1
	MCH	1	0	23.88	0
		1	49	24.52	0
		1	99	24.70	0
		50	0	24.40	1
		50	25	23.56	1
		50	50	23.52	1
		100	0	23.29	1
	HCH	1	0	23.53	0
		1	49	24.29	0
		1	99	24.68	0
		50	0	24.41	0.5
		50	25	23.47	0.5
		50	50	23.64	0.5
		100	0	23.48	0.5
16QAM	LCH	1	0	23.43	1
		1	49	23.95	1

		1	99	24.20	1
		50	0	23.44	2
		50	25	23.05	2
		50	50	22.78	2
		100	0	22.78	2
	MCH	1	0	22.96	1
		1	49	23.85	1
		1	99	23.98	1
		50	0	23.26	2
		50	25	22.62	2
		50	50	22.63	2
		100	0	22.41	2
	HCH	1	0	22.50	1
		1	49	23.67	1
		1	99	23.95	1
		50	0	23.23	2
		50	25	22.48	2
		50	50	22.70	2
		100	0	22.54	2

Remark:

- Per KDB941225 D05 v02r05, Start with the largest channel bandwidth then measure SAR for QPSK with 1 RB allocation, using the RB offset and required test channel combination with the highest maximum output power among RB offsets at the upper edge, middle, and lower edge of each required test channel. When the reported SAR is ≤ 0.8 W/kg, testing of the remaining RB offset configurations and required test channels is not required for 1 RB allocation; otherwise, SAR is required for the remaining required test channels and only for the RB offset configuration with the highest output power for that channel. 6 When the reported SAR of a required test channel is > 1.45 W/kg, SAR is required for all three RB offset configurations for that required test channel.
- Per KDB941225 D05 v02r05, The procedures required for 1 RB allocation in 5.2.1 are applied to measure the SAR for QPSK with 50% RB allocation.
- Per KDB941225 D05 v02r05, For QPSK with 100% RB allocation, SAR is not required when the highest maximum output power for 100 % RB allocation is less than the highest maximum output power in 50% and 1 RB allocations, and the highest reported SAR for 1 RB and 50% RB allocation in 5.2.1 and 5.2.2 are ≤ 0.8 W/kg. Otherwise, SAR is measured for the highest output power channel; and if the reported SAR is > 1.45 W/kg, the remaining required test channels must also be tested.
- Per KDB941225 D05 v02r05, For each modulation besides QPSK; e.g., 16-QAM, 64-QAM, apply the QPSK procedures in 5.2.1, 5.2.2, and 5.2.3 to determine the QAM configurations that may need SAR measurement. For each configuration identified as required for testing, SAR is required only when the highest maximum output power for the configuration in the higher order modulation is $> \frac{1}{2}$ dB higher than the same configuration in QPSK or when the reported SAR for the QPSK configuration is > 1.45 W/kg.

WLAN(2.4G) - Maximum Average Power					
Test Mode	Data Rate	Channel	Frequency (MHz)	Average Power (dBm)	Tune-up power (dBm)
802.11b	1Mbps	CH 01	2412	17.47	18.0
		CH 06	2437	14.72	18.0
		CH 11	2462	17.52	18.0
802.11g	54Mbps	CH 01	2412	16.61	17.0
		CH 06	2437	13.58	17.0
		CH 11	2462	16.61	17.0
802.11n (20MHz)	MCS7	CH 01	2412	16.43	17.0
		CH 06	2437	13.88	17.0
		CH 11	2462	16.74	17.0
802.11n (40MHz)	MCS7	CH 03	2422	15.19	15.5
		CH 06	2437	12.98	15.5
		CH 09	2452	13.94	15.5

WLAN(5.2G)- Maximum Average Power				
Test Mode	Channel	Frequency	Average Power	Tune-up power
		(MHz)	(dBm)	(dBm)
802.11a	CH 36	5180	14.27	15.0
	CH 40	5200	13.77	15.0
	CH 48	5240	14.74	15.0
802.11n-20	CH 36	5180	10.51	12.0
	CH 40	5200	11.25	12.0
	CH 48	5240	11.56	12.0
802.11n -40	CH 38	5190	10.45	11.0
	CH46	5230	10.91	11.0
802.11ac -80	CH 42	5210	10.97	11.0

WLAN(5.3G)- Maximum Average Power				
Test Mode	Channel	Frequency	Average Power	Tune-up power
		(MHz)	(dBm)	(dBm)
802.11a	CH 52	5260	10.71	11.0
	CH 56	5280	10.94	11.0
	CH 64	5320	10.86	11.0

802.11n-20	CH 52	5260	10.51	11.0
	CH 56	5280	10.58	11.0
	CH 64	5320	10.51	11.0
802.11n -40	CH 54	5270	10.99	11.0
	CH 62	5310	10.84	11.0
802.11ac -80	CH 58	5290	10.31	11.0

WLAN(5.6G)- Maximum Average Power				
Test Mode	Channel	Frequency	Average Power	Tune-up power
		(MHz)	(dBm)	(dBm)
802.11a	CH 100	5500	11.82	12.0
	CH 120	5600	11.59	12.0
	CH 140	5700	10	12.0
802.11n-20	CH 100	5500	11.29	11.5
	CH 120	5600	11	11.5
	CH 140	5700	9.97	11.5
802.11n -40	CH 102	5510	11.4	11.5
	CH118	5590	10.57	11.5
	CH134	5670	10.6	11.5
802.11ac -80	CH106	5530	10.59	11.0
	CH122	5610	10.11	11.0

WLAN(5.8G) - Maximum Average Power				
Test Mode	Channel	Frequency	Average Power	Tune-up power
		(MHz)	(dBm)	(dBm)
802.11a	CH149	5745	12.74	14.0
	CH157	5785	12.65	14.0
	CH165	5825	13.79	14.0
802.11n-20	CH149	5745	12.22	13.0
	CH157	5785	12.97	13.0
	CH165	5825	12.81	13.0
802.11n -40	CH151	5755	12.57	13.0
	CH159	5795	12.49	13.0
802.11ac -80	CH155	5775	12.05	13.0

Remark:

1. Per KDB 248227 D01 v02r02, For 802.11b DSSS SAR measurements, DSSS SAR procedure applies to fixed exposure test position and initial test position procedure applies to multiple exposure test positions.

2. Per KDB 248227 D01 v02r02, For 802.11b DSSS SAR measurements ,when the reported SAR of the highest measured maximum output power channel (see 3.1) for the exposure configuration is ≤ 0.8 W/kg, no further SAR testing is required for 802.11b DSSS in that exposure configuration. When the reported SAR is > 0.8 W/kg, SAR is required for that exposure configuration using the next highest measured output power channel. When any reported SAR is > 1.2 W/kg, SAR is required for the third channel; i.e., all channels require testing.

3 .For OFDM modes (802.11g/n), SAR is not required when the highest reported SAR for DSSS is adjusted by the ratio of OFDM to DSSS specified maximum output power and it is ≤ 1.2 W/kg.

4. Per KDB 248227 D01 v02r02, When multiple channel bandwidth configurations in a frequency band have the same specified maximum output power, the initial test configuration is determined by applying the following steps sequentially.

1) The largest channel bandwidth configuration is selected among the multiple configurations in a frequency band with the same specified maximum output power.

2) If multiple configurations have the same specified maximum output power and largest channel bandwidth, the lowest order modulation among the largest channel bandwidth configurations is selected.

3) If multiple configurations have the same specified maximum output power, largest channel bandwidth and lowest order modulation, the lowest data rate configuration among these configurations is selected.

4) When multiple transmission modes (802.11a/g/n/ac) have the same specified maximum output power, largest channel bandwidth, lowest order modulation and lowest data rate, the lowest order 802.11 mode is selected; i.e., 802.11a is chosen over 802.11n then 802.11ac or 802.11g is chosen over 802.11n.

Bluetooth - Maximum Average Power			
Test Mode	Data Rate	Average Power(dBm)	Tune-up power (dBm)
GFSK	1Mbps	7.857	8.0
Pi/4 QDPSK	2Mbps	7.395	8.0
8DPSK	3Mbps	7.4	8.0

Bluetooth - Maximum Average Power					
Test Mode	Data Rate	Channel	Frequency (MHz)	Average Power (dBm)	Tune-up power (dBm)
BLE	1Mbps	CH 00	2402	-5.457	-4.5
		CH 19	2440	-6.027	-4.5
		CH 39	2480	-4.96	-4.5

NFC - Maximum Average Power			
Test Mode	Frequency (MHz)	Average Power(dBm)	Tune-up power (dBm)
NFC	13.56	-48.96	-48.5

Remark:

Bluetooth and NFC maximum output power is 7.857dBm and -48.96dBm *respectively*, and Maximum Tune-Up output power is 4.0dBm and -25dBm *respectively*. Per KDB 447498 D01 V06, the 1-g and 10-g SAR test exclusion thresholds for 100 MHz to 6 GHz at test separation distances ≤ 50 mm are determined by:

$[(\text{max. power of channel, including tune-up tolerance, } 4.87\text{mW}) / (\text{min. test separation distance, mm})] \cdot [\sqrt{f(\text{GHz})}] \leq 3.0$ for 1-g SAR and ≤ 7.5 for 10-g extremity SAR, 16 where

- f(GHz) is the RF channel transmit frequency in GHz
- Power and distance are rounded to the nearest mW and mm before calculation¹⁷
- The result is rounded to one decimal place for comparison

Bluetooth:

Tune-Up Power (dBm)	Max. Power (mW)	Distance (mm)	Frequency (GHz)	Result	Limit
8.0	6.31	5	2.402	1.96	3

The exclusion thresholds is $1.96 < 3$, therefore, the RF exposure evaluation is not required.

NFC:

Tune-Up Power (dBm)	Max. Power (mW)	Distance (mm)	Frequency (GHz)	Result	Limit
-48.5	0.0000141	5	0.01356	0.000003	3

The exclusion thresholds is $0.000003 < 3$, therefore, the RF exposure evaluation is not required.

9.2 Test Results for Standalone SAR Test

Head SAR

GSM850 – Head SAR Test									
Plot No.	Mode	Test Position Head	Frequency		Output Power (dBm)	Rated Limit (dBm)	Scaling Factor	SAR1g (W/kg)	Scaled SAR1g (W/kg)
			CH.	MHz					
1.	GSM	Right Cheek	128	824.2	32.64	33.0	1.086	0.434	0.472
2.	GSM	Right Tilted	128	824.2	32.64	33.0	1.086	0.233	0.253
3.	GSM	Left Cheek	128	824.2	32.64	33.0	1.086	0.474	0.515
4.	GSM	Left Tilted	128	824.2	32.64	33.0	1.086	0.251	0.273

GSM1900 – Head SAR Test									
Plot No.	Mode	Test Position Head	Frequency		Output Power (dBm)	Rated Limit (dBm)	Scaling Factor	SAR1g (W/kg)	Scaled SAR1g (W/kg)
			CH.	M Hz					
5.	GSM	Right Cheek	810	1909.8	29.9	30.0	1.023	0.300	0.307
6.	GSM	Right Tilted	810	1909.8	29.9	30.0	1.023	0.166	0.170
7.	GSM	Left Cheek	810	1909.8	29.9	30.0	1.023	0.21	0.215
8.	GSM	Left Tilted	810	1909.8	29.9	30.0	1.023	0.118	0.121

GPRS850 – Head SAR Test									
Plot No.	Mode	Test Position Head	Frequency		Output Power (dBm)	Rated Limit (dBm)	Scaling Factor	SAR1g (W/kg)	Scaled SAR1g (W/kg)
			CH.	MHz					
9.	GPRS_4TX	Right Cheek	128	824.2	29.59	30.0	1.099	0.830	0.912
10.	GPRS_4TX	Right Cheek	190	836.6	29.44	30.0	1.138	0.756	0.860
11.	GPRS_4TX	Right Cheek	251	848.8	29.57	30.0	1.104	0.560	0.618
12.	GPRS_4TX	Right Tilted	128	824.2	29.59	30.0	1.099	0.477	0.524
13.	GPRS_4TX	Left Cheek	128	824.2	29.59	30.0	1.099	0.976	1.073
14.	GPRS_4TX	Left Cheek	190	836.6	29.44	30.0	1.138	0.840	0.956
15.	GPRS_4TX	Left Cheek	251	848.8	29.57	30.0	1.104	0.636	0.702
16.	GPRS_4TX	Left Tilted	128	824.2	29.59	30.0	1.099	0.492	0.541

GPRS1900 – Head SAR Test									
Plot No.	Mode	Test Position Head	Frequency		Output Power (dBm)	Rated Limit (dBm)	Scaling Factor	SAR1g (W/kg)	Scaled SAR1g (W/kg)
			CH.	M Hz					
17.	GPRS_2TX	Right Cheek	810	1909.8	29.22	29.5	1.067	0.540	0.576
18.	GPRS_2TX	Right Tilted	810	1909.8	29.22	29.5	1.067	0.331	0.353
19.	GPRS_2TX	Left Cheek	810	1909.8	29.22	29.5	1.067	0.357	0.381
20.	GPRS_2TX	Left Tilted	810	1909.8	29.22	29.5	1.067	0.169	0.180

WCDMA Band 2 – Head SAR Test									
Plot No.	Mode	Test Position Head	Frequency		Output Power (dBm)	Rated Limit (dBm)	Scaling Factor	SAR1g (W/kg)	Scaled SAR1g (W/kg)
			CH.	MHz					
21.	RMC	Right Cheek	9538	1907.6	22.29	22.5	1.050	0.524	0.550
22.	RMC	Right Tilted	9538	1907.6	22.29	22.5	1.050	0.311	0.326
23.	RMC	Left Cheek	9538	1907.6	22.29	22.5	1.050	0.335	0.352
24.	RMC	Left Tilted	9538	1907.6	22.29	22.5	1.050	0.157	0.165

WCDMA Band 5 – Head SAR Test									
Plot No.	Mode	Test Position Head	Frequency		Output Power (dBm)	Rated Limit (dBm)	Scaling Factor	SAR1g (W/kg)	Scaled SAR1g (W/kg)
			CH.	MHz					
25.	RMC	Right Cheek	4182	836.6	22.45	22.5	1.012	0.191	0.193
26.	RMC	Right Tilted	4182	836.6	22.45	22.5	1.012	0.112	0.113
27.	RMC	Left Cheek	4182	836.6	22.45	22.5	1.012	0.196	0.198
28.	RMC	Left Tilted	4182	836.6	22.45	22.5	1.012	0.118	0.119

WCDMA Band 4 – Head SAR Test									
Plot No.	Mode	Test Position Head	Frequency		Output Power (dBm)	Rated Limit (dBm)	Scaling Factor	SAR1g (W/kg)	Scaled SAR1g (W/kg)
			CH.	MHz					
29.	RMC	Right Cheek	1513	1752.6	21.36	21.5	1.033	0.430	0.444
30.	RMC	Right Tilted	1513	1752.6	21.36	21.5	1.033	0.233	0.241
31.	RMC	Left Cheek	1513	1752.6	21.36	21.5	1.033	0.254	0.262
32.	RMC	Left Tilted	1513	1752.6	21.36	21.5	1.033	0.161	0.166

LTE Band 2– Head SAR Test									
Plot No.	Mode	Test Position Head	Frequency MHz	Output Power (dBm)	Rated Limit (dBm)	Scaling Factor	SAR1g (W/kg)	Scaled SAR1g (W/kg)	
	Modulation, Bandwidth, RB								
33.	RMC QPSK 20MHz 1RB	Right Cheek	1860.0	22.77	23.0	1.054	0.064	0.067	
34.	RMC QPSK 20MHz 1RB	Right Tilted	1860.0	22.77	23.0	1.054	0.033	0.035	
35.	RMC QPSK 20MHz 1RB	Left Cheek	1860.0	22.77	23.0	1.054	0.041	0.043	
36.	RMC QPSK 20MHz 1RB	Left Tilted	1860.0	22.77	23.0	1.054	0.025	0.026	
37.	RMC QPSK 20MHz 50%RB	Right Cheek	1860.0	22.77	23.0	1.054	0.031	0.033	
38.	RMC QPSK 20MHz 50%RB	Right Tilted	1860.0	22.77	23.0	1.054	0.017	0.018	
39.	RMC QPSK 20MHz 50%RB	Left Cheek	1860.0	22.77	23.0	1.054	0.023	0.024	
40.	RMC QPSK 20MHz 50%RB	Left Tilted	1860.0	22.77	23.0	1.054	0.014	0.015	

LTE Band 4– Head SAR Test								
Plot No.	Mode	Test Position Head	Freque ncy	Output Power (dBm)	Rated Limit (dBm)	Scaling Factor	SAR1g (W/kg)	Scaled SAR1g (W/kg)
	Modulation, Bandwidth, RB		MHz					
41.	RMC QPSK 20MHz 1RB	Right Cheek	1720.0	23.30	23.5	1.047	0.088	0.092
42.	RMC QPSK 20MHz 1RB	Right Tilted	1720.0	23.30	23.5	1.047	0.042	0.044
43.	RMC QPSK 20MHz 1RB	Left Cheek	1720.0	23.30	23.5	1.047	0.045	0.047
44.	RMC QPSK 20MHz 1RB	Left Tilted	1720.0	23.30	23.5	1.047	0.028	0.029
45.	RMC QPSK 20MHz 50%RB	Right Cheek	1720.0	23.30	23.5	1.047	0.045	0.047
46.	RMC QPSK 20MHz 50%RB	Right Tilted	1720.0	23.30	23.5	1.047	0.023	0.024
47.	RMC QPSK 20MHz 50%RB	Left Cheek	1720.0	23.30	23.5	1.047	0.025	0.026
48.	RMC QPSK 20MHz 50%RB	Left Tilted	1720.0	23.30	23.5	1.047	0.016	0.017

LTE Band 5– Head SAR Test								
Plot No.	Mode	Test Position Head	Freque ncy	Output Power (dBm)	Rated Limit (dBm)	Scaling Factor	SAR1g (W/kg)	Scaled SAR1g (W/kg)
	Modulation, Bandwidth		MHz					
49.	RMC QPSK 10MHz 1RB	Right Cheek	829.0	23.45	23.5	1.012	0.003	0.003
50.	RMC QPSK 10MHz 1RB	Right Tilted	829.0	23.45	23.5	1.012	0.001	0.001
51.	RMC QPSK 10MHz 1RB	Left Cheek	829.0	23.45	23.5	1.012	0.003	0.003
52.	RMC QPSK 10MHz 1RB	Left Tilted	829.0	23.45	23.5	1.012	0.001	0.001
53.	RMC QPSK 10MHz 50%RB	Right Cheek	829.0	23.45	23.5	1.012	0.003	0.003
54.	RMC QPSK 10MHz 50%RB	Right Tilted	829.0	23.45	23.5	1.012	0.001	0.001
55.	RMC QPSK 10MHz 50%RB	Left Cheek	829.0	23.45	23.5	1.012	0.002	0.002
56.	RMC QPSK 10MHz 50%RB	Left Tilted	829.0	23.45	23.5	1.012	0.001	0.001

LTE Band 7– Head SAR Test								
Plot No.	Mode	Test Position Head	Freque ncy	Output Power (dBm)	Rated Limit (dBm)	Scaling Factor	SAR1g (W/kg)	Scaled SAR1g (W/kg)
	Modulation, Bandwidth		MHz					
57.	RMC QPSK 20MHz 1RB	Right Cheek	2560.0	23.28	23.5	1.052	0.373	0.392
58.	RMC QPSK 20MHz 1RB	Right Tilted	2560.0	23.28	23.5	1.052	0.198	0.208
59.	RMC QPSK 20MHz 1RB	Left Cheek	2560.0	23.28	23.5	1.052	0.143	0.150
60.	RMC QPSK 20MHz 1RB	Left Tilted	2560.0	23.28	23.5	1.052	0.103	0.108
61.	RMC QPSK 20MHz 50%RB	Right Cheek	2560.0	23.28	23.5	1.052	0.188	0.198
62.	RMC QPSK 20MHz 50%RB	Right Tilted	2560.0	23.28	23.5	1.052	0.102	0.107
63.	RMC QPSK 20MHz 50%RB	Left Cheek	2560.0	23.28	23.5	1.052	0.087	0.092
64.	RMC QPSK 20MHz 50%RB	Left Tilted	2560.0	23.28	23.5	1.052	0.056	0.059

LTE Band 12– Head SAR Test								
Plot No.	Mode	Test Position Head	Frequency	Output Power (dBm)	Rated Limit (dBm)	Scaling Factor	SAR1g (W/kg)	Scaled SAR1g (W/kg)
	Modulation, Bandwidth		MHz					
65.	RMC QPSK 10MHz 1RB	Right Cheek	707.5	22.91	23.0	1.021	0.012	0.012
66.	RMC QPSK 10MHz 1RB	Right Tilted	707.5	22.91	23.0	1.021	0.007	0.007
67.	RMC QPSK 10MHz 1RB	Left Cheek	707.5	22.91	23.0	1.021	0.016	0.016
68.	RMC QPSK 10MHz 1RB	Left Tilted	707.5	22.91	23.0	1.021	0.009	0.009
69.	RMC QPSK 10MHz 50%RB	Right Cheek	707.5	22.91	23.0	1.021	0.008	0.008
70.	RMC QPSK 10MHz 50%RB	Right Tilted	707.5	22.91	23.0	1.021	0.004	0.004
71.	RMC QPSK 10MHz 50%RB	Left Cheek	707.5	22.91	23.0	1.021	0.007	0.007
72.	RMC QPSK 10MHz 50%RB	Left Tilted	707.5	22.91	23.0	1.021	0.005	0.005

LTE Band 13– Head SAR Test								
Plot No.	Mode	Test Position Head	Frequency	Output Power (dBm)	Rated Limit (dBm)	Scaling Factor	SAR1g (W/kg)	Scaled SAR1g (W/kg)
	Modulation, Bandwidth		MHz					
73.	RMC QPSK 10MHz 1RB	Right Cheek	782.0	24.11	24.5	1.094	0.005	0.005
74.	RMC QPSK 10MHz 1RB	Right Tilted	782.0	24.11	24.5	1.094	0.002	0.002
75.	RMC QPSK 10MHz 1RB	Left Cheek	782.0	24.11	24.5	1.094	0.006	0.007
76.	RMC QPSK 10MHz 1RB	Left Tilted	782.0	24.11	24.5	1.094	0.003	0.003
77.	RMC QPSK 10MHz 50%RB	Right Cheek	782.0	24.11	24.5	1.094	0.003	0.003
78.	RMC QPSK 10MHz 50%RB	Right Tilted	782.0	24.11	24.5	1.094	0.001	0.001
79.	RMC QPSK 10MHz 50%RB	Left Cheek	782.0	24.11	24.5	1.094	0.004	0.004
80.	RMC QPSK 10MHz 50%RB	Left Tilted	782.0	24.11	24.5	1.094	0.002	0.002

LTE Band 17– Head SAR Test								
Plot No.	Mode	Test Position Head	Frequency	Output Power (dBm)	Rated Limit (dBm)	Scaling Factor	SAR1g (W/kg)	Scaled SAR1g (W/kg)
	Modulation, Bandwidth		MHz					
81.	RMC QPSK 5MHz 1RB	Right Cheek	713.5	23.34	23.5	1.038	0.011	0.011
82.	RMC QPSK 5MHz 1RB	Right Tilted	713.5	23.34	23.5	1.038	0.006	0.006
83.	RMC QPSK 5MHz 1RB	Left Cheek	713.5	23.34	23.5	1.038	0.013	0.013
84.	RMC QPSK 5MHz 1RB	Left Tilted	713.5	23.34	23.5	1.038	0.008	0.008
85.	RMC QPSK 5MHz 50%RB	Right Cheek	713.5	23.34	23.5	1.038	0.006	0.006
86.	RMC QPSK 5MHz 50%RB	Right Tilted	713.5	23.34	23.5	1.038	0.004	0.004
87.	RMC QPSK 5MHz 50%RB	Left Cheek	713.5	23.34	23.5	1.038	0.007	0.007
88.	RMC QPSK 5MHz 50%RB	Left Tilted	713.5	23.34	23.5	1.038	0.005	0.005

LTE Band 25– Head SAR Test								
Plot No.	Mode	Test Position Head	Freque ncy	Output Power (dBm)	Rated Limit (dBm)	Scaling Factor	SAR1g (W/kg)	Scaled SAR1g (W/kg)
	Modulation, Bandwidth, RB		MHz					
89.	RMC QPSK 10MHz 1RB	Right Cheek	1855.0	22.48	22.5	1.005	0.039	0.039
90.	RMC QPSK 10MHz 1RB	Right Tilted	1855.0	22.48	22.5	1.005	0.019	0.019
91.	RMC QPSK 10MHz 1RB	Left Cheek	1855.0	22.48	22.5	1.005	0.021	0.021
92.	RMC QPSK 10MHz 1RB	Left Tilted	1855.0	22.48	22.5	1.005	0.015	0.015
93.	RMC QPSK 10MHz 50%RB	Right Cheek	1855.0	22.48	22.5	1.005	0.018	0.018
94.	RMC QPSK 10MHz 50%RB	Right Tilted	1855.0	22.48	22.5	1.005	0.011	0.011
95.	RMC QPSK 10MHz 50%RB	Left Cheek	1855.0	22.48	22.5	1.005	0.012	0.012
96.	RMC QPSK 10MHz 50%RB	Left Tilted	1855.0	22.48	22.5	1.005	0.008	0.008

LTE Band 26– Head SAR Test								
Plot No.	Mode	Test Position Head	Freque ncy	Output Power (dBm)	Rated Limit (dBm)	Scaling Factor	SAR1g (W/kg)	Scaled SAR1g (W/kg)
	Modulation, Bandwidth		MHz					
97.	RMC QPSK 10MHz 1RB	Right Cheek	831.0	23.59	24.0	1.099	0.005	0.005
98.	RMC QPSK 10MHz 1RB	Right Tilted	831.0	23.59	24.0	1.099	0.003	0.003
99.	RMC QPSK 10MHz 1RB	Left Cheek	831.0	23.59	24.0	1.099	0.007	0.008
100.	RMC QPSK 10MHz 1RB	Left Tilted	831.0	23.59	24.0	1.099	0.004	0.004
101.	RMC QPSK 10MHz 50%RB	Right Cheek	831.0	23.59	24.0	1.099	0.003	0.003
102.	RMC QPSK 10MHz 50%RB	Right Tilted	831.0	23.59	24.0	1.099	0.002	0.002
103.	RMC QPSK 10MHz 50%RB	Left Cheek	831.0	23.59	24.0	1.099	0.004	0.004
104.	RMC QPSK 10MHz 50%RB	Left Tilted	831.0	23.59	24.0	1.099	0.002	0.002

LTE Band 30– Head SAR Test								
Plot No.	Mode	Test Position Head	Freque ncy	Output Power (dBm)	Rated Limit (dBm)	Scaling Factor	SAR1g (W/kg)	Scaled SAR1g (W/kg)
	Modulation, Bandwidth		MHz					
105.	RMC QPSK 10MHz 1RB	Right Cheek	2310.0	23.89	24.0	1.026	0.195	0.200
106.	RMC QPSK 10MHz 1RB	Right Tilted	2310.0	23.89	24.0	1.026	0.112	0.115
107.	RMC QPSK 10MHz 1RB	Left Cheek	2310.0	23.89	24.0	1.026	0.100	0.103
108.	RMC QPSK 10MHz 1RB	Left Tilted	2310.0	23.89	24.0	1.026	0.051	0.052
109.	RMC QPSK 10MHz 50%RB	Right Cheek	2310.0	23.89	24.0	1.026	0.112	0.115
110.	RMC QPSK 10MHz 50%RB	Right Tilted	2310.0	23.89	24.0	1.026	0.065	0.067
111.	RMC QPSK 10MHz 50%RB	Left Cheek	2310.0	23.89	24.0	1.026	0.058	0.059
112.	RMC QPSK 10MHz 50%RB	Left Tilted	2310.0	23.89	24.0	1.026	0.029	0.030

LTE Band 40:2305-2315MHz– Head SAR Test								
Plot No.	Mode	Test Position Head	Freque ncy	Output Power (dBm)	Rated Limit (dBm)	Scaling Factor	SAR1g (W/kg)	Scaled SAR1g (W/kg)
	Modulation, Bandwidth		MHz					
113.	RMC QPSK 10MHz 1RB	Right Cheek	2310.0	22.86	23.0	1.033	0.081	0.084
114.	RMC QPSK 10MHz 1RB	Right Tilted	2310.0	22.86	23.0	1.033	0.044	0.045
115.	RMC QPSK 10MHz 1RB	Left Cheek	2310.0	22.86	23.0	1.033	0.035	0.036
116.	RMC QPSK 10MHz 1RB	Left Tilted	2310.0	22.86	23.0	1.033	0.019	0.020
117.	RMC QPSK 10MHz 50%RB	Right Cheek	2310.0	22.86	23.0	1.033	0.042	0.043
118.	RMC QPSK 10MHz 50%RB	Right Tilted	2310.0	22.86	23.0	1.033	0.023	0.024
119.	RMC QPSK 10MHz 50%RB	Left Cheek	2310.0	22.86	23.0	1.033	0.019	0.020
120.	RMC QPSK 10MHz 50%RB	Left Tilted	2310.0	22.86	23.0	1.033	0.011	0.011

LTE Band 40: 2350-2360MHz– Head SAR Test								
Plot No.	Mode	Test Position Head	Freque ncy	Output Power (dBm)	Rated Limit (dBm)	Scaling Factor	SAR1g (W/kg)	Scaled SAR1g (W/kg)
	Modulation, Bandwidth		MHz					
121.	RMC QPSK 10MHz 1RB	Right Cheek	2355.0	22.97	23.0	1.007	0.095	0.096
122.	RMC QPSK 10MHz 1RB	Right Tilted	2355.0	22.97	23.0	1.007	0.051	0.051
123.	RMC QPSK 10MHz 1RB	Left Cheek	2355.0	22.97	23.0	1.007	0.037	0.037
124.	RMC QPSK 10MHz 1RB	Left Tilted	2355.0	22.97	23.0	1.007	0.018	0.018
125.	RMC QPSK 10MHz 50%RB	Right Cheek	2355.0	22.97	23.0	1.007	0.051	0.051
126.	RMC QPSK 10MHz 50%RB	Right Tilted	2355.0	22.97	23.0	1.007	0.027	0.027
127.	RMC QPSK 10MHz 50%RB	Left Cheek	2355.0	22.97	23.0	1.007	0.018	0.018
128.	RMC QPSK 10MHz 50%RB	Left Tilted	2355.0	22.97	23.0	1.007	0.009	0.009

LTE Band 66– Head SAR Test								
Plot No.	Mode	Test Position Head	Freque ncy	Output Power (dBm)	Rated Limit (dBm)	Scaling Factor	SAR1g (W/kg)	Scaled SAR1g (W/kg)
	Modulation, Bandwidth		MHz					
129.	RMC QPSK 5MHz 1RB	Right Cheek	1712.5	25.47	25.5	1.007	0.057	0.057
130.	RMC QPSK 5MHz 1RB	Right Tilted	1712.5	25.47	25.5	1.007	0.029	0.029
131.	RMC QPSK 5MHz 1RB	Left Cheek	1712.5	25.47	25.5	1.007	0.034	0.034
132.	RMC QPSK 5MHz 1RB	Left Tilted	1712.5	25.47	25.5	1.007	0.018	0.018
133.	RMC QPSK 5MHz 50%RB	Right Cheek	1712.5	25.47	25.5	1.007	0.031	0.031
134.	RMC QPSK 5MHz 50%RB	Right Tilted	1712.5	25.47	25.5	1.007	0.018	0.018
135.	RMC QPSK 5MHz 50%RB	Left Cheek	1712.5	25.47	25.5	1.007	0.019	0.019
136.	RMC QPSK 5MHz 50%RB	Left Tilted	1712.5	25.47	25.5	1.007	0.009	0.009

WLAN 2.4GHz – Head SAR Test									
Plot No.	Mode	Test Position Head	Frequency		Output Power (dBm)	Rated Limit (dBm)	Scaling Factor	SAR1g (W/kg)	Scaled SAR1g (W/kg)
			CH.	MHz					
137.	802.11b	Right Cheek	11	2462	17.52	18.0	1.117	0.325	0.363
138.	802.11b	Right Tilted	11	2462	17.52	18.0	1.117	0.234	0.261
139.	802.11b	Left Cheek	11	2462	17.52	18.0	1.117	0.142	0.159
140.	802.11b	Left Tilted	11	2462	17.52	18.0	1.117	0.101	0.113

WLAN 5.2GHz – Head SAR Test									
Plot No.	Mode	Test Position Head	Frequency		Output Power (dBm)	Rated Limit (dBm)	Scaling Factor	SAR1g (W/kg)	Scaled SAR1g (W/kg)
			CH.	MHz					
141.	802.11a	Right Cheek	48	5240	14.74	15.0	1.062	0.349	0.371
142.	802.11a	Right Tilted	48	5240	14.74	15.0	1.062	0.132	0.140
143.	802.11a	Left Cheek	48	5240	14.74	15.0	1.062	0.124	0.132
144.	802.11a	Left Tilted	48	5240	14.74	15.0	1.062	0.065	0.069

WLAN 5.3GHz – Head SAR Test									
Plot No.	Mode	Test Position Head	Frequency		Output Power (dBm)	Rated Limit (dBm)	Scaling Factor	SAR1g (W/kg)	Scaled SAR1g (W/kg)
			CH.	MHz					
145.	802.11n-40	Right Cheek	54	5270	10.99	11.0	1.002	0.058	0.058
146.	802.11n-40	Right Tilted	54	5270	10.99	11.0	1.002	0.031	0.031
147.	802.11n-40	Left Cheek	54	5270	10.99	11.0	1.002	0.138	0.138
148.	802.11n-40	Left Tilted	54	5270	10.99	11.0	1.002	0.072	0.072

WLAN 5.6GHz – Head SAR Test									
Plot No.	Mode	Test Position Head	Frequency		Output Power (dBm)	Rated Limit (dBm)	Scaling Factor	SAR1g (W/kg)	Scaled SAR1g (W/kg)
			CH.	MHz					
149.	802.11a	Right Cheek	100	5500	11.82	12.0	1.042	0.108	0.113
150.	802.11a	Right Tilted	100	5500	11.82	12.0	1.042	0.055	0.057
151.	802.11a	Left Cheek	100	5500	11.82	12.0	1.042	0.306	0.319
152.	802.11a	Left Tilted	100	5500	11.82	12.0	1.042	0.163	0.170

WLAN 5.8GHz – Head SAR Test									
Plot No.	Mode	Test Position Head	Frequency		Output Power (dBm)	Rated Limit (dBm)	Scaling Factor	SAR1g (W/kg)	Scaled SAR1g (W/kg)
			CH.	MHz					
153.	802.11a	Right Cheek	165	5825	13.79	14.0	1.050	0.105	0.110
154.	802.11a	Right Tilted	165	5825	13.79	14.0	1.050	0.052	0.055
155.	802.11a	Left Cheek	165	5825	13.79	14.0	1.050	0.065	0.068
156.	802.11a	Left Tilted	165	5825	13.79	14.0	1.050	0.033	0.035

Remark: Per KDB 447498 D01 v06, if the highest output channel SAR for each exposure position ≤ 0.8 W/kg other channels SAR tests are not necessary.

Body-worn SAR

GSM850 – Body SAR Test (Gap: 10mm)									
Plot No.	Mode	Test Position Body	Frequency		Output Power (dBm)	Rated Limit (dBm)	Scaling Factor	SAR1g (W/kg)	Scaled SAR1g (W/kg)
			CH.	MHz					
157.	GSM	Back	128	824.2	32.64	33.0	1.086	0.508	0.552
158.	GSM	Front	128	824.2	32.64	33.0	1.086	0.420	0.456

GSM1900 – Body SAR Test (Gap: 10mm)									
Plot No.	Mode	Test Position Body	Frequency		Output Power (dBm)	Rated Limit (dBm)	Scaling Factor	SAR1g (W/kg)	Scaled SAR1g (W/kg)
			CH.	MHz					
159.	GSM	Back	810	1909.8	29.9	30.0	1.023	0.588	0.602
160.	GSM	Front	810	1909.8	29.9	30.0	1.023	0.533	0.545

WCDMA Band 2 – Body SAR Test (Gap: 10mm)									
Plot No.	Mode	Test Position Body	Frequency		Output Power (dBm)	Rated Limit (dBm)	Scaling Factor	SAR1g (W/kg)	Scaled SAR1g (W/kg)
			CH.	MHz					
161.	RMC 12.2k	Back Side	9538	1907.6	22.29	22.5	1.050	0.809	0.849
162.	RMC 12.2k	Back Side	9262	1852.4	22.09	22.5	1.099	0.842	0.925
163.	RMC 12.2k	Back Side	9400	1880.0	22.14	22.5	1.086	0.846	0.919
164.	RMC 12.2k	Front Side	9538	1907.6	22.29	22.5	1.050	0.745	0.782

WCDMA Band 5 – Body SAR Test (Gap: 10mm)									
Plot No.	Mode	Test Position Body	Frequency		Output Power (dBm)	Rated Limit (dBm)	Scaling Factor	SAR1g (W/kg)	Scaled SAR1g (W/kg)
			CH.	MHz					
165.	RMC 12.2k	Back Side	4182	836.6	22.45	22.5	1.012	0.271	0.274
166.	RMC 12.2k	Front Side	4182	836.6	22.45	22.5	1.012	0.212	0.214

WCDMA Band 4– Body SAR Test (Gap: 10mm)									
Plot No.	Mode	Test Position Body	Frequency		Output Power (dBm)	Rated Limit (dBm)	Scaling Factor	SAR1g (W/kg)	Scaled SAR1g (W/kg)
			CH.	MHz					
167.	RMC 12.2k	Back Side	1513	1752.6	21.36	21.5	1.033	1.078	1.113
168.	RMC 12.2k	Back Side	1312	1712.4	21.22	21.5	1.067	1.035	1.104
169.	RMC 12.2k	Back Side	1412	1732.4	21.27	21.5	1.054	1.051	1.108
170.	RMC 12.2k	Front Side	1513	1752.6	21.36	21.5	1.033	0.719	0.743

LTE Band 2–Body SAR Test (Gap: 10mm)								
Plot No.	Mode	Test Position Body	Frequency	Output Power (dBm)	Rated Limit (dBm)	Scaling Factor	SAR1g (W/kg)	Scaled SAR1g (W/kg)
	Modulation, Bandwidth, RB		MHz					
171.	RMC QPSK 20MHz 1RB	Back Side	1860.0	22.77	23.0	1.054	0.469	0.495
172.	RMC QPSK 20MHz 1RB	Front Side	1860.0	22.77	23.0	1.054	0.384	0.405
173.	RMC QPSK 20MHz 50%RB	Back Side	1860.0	22.77	23.0	1.054	0.233	0.246
174.	RMC QPSK 20MHz 50%RB	Front Side	1860.0	22.77	23.0	1.054	0.156	0.164

LTE Band 4–Body SAR Test (Gap: 10mm)								
Plot No.	Mode	Test Position Body	Frequency	Output Power (dBm)	Rated Limit (dBm)	Scaling Factor	SAR1g (W/kg)	Scaled SAR1g (W/kg)
	Modulation, Bandwidth, RB		MHz					
175.	RMC QPSK 20MHz 1RB	Back Side	1720.0	23.30	23.5	1.047	0.382	0.400
176.	RMC QPSK 20MHz 1RB	Front Side	1720.0	23.30	23.5	1.047	0.317	0.332
177.	RMC QPSK 20MHz 50%RB	Back Side	1720.0	23.30	23.5	1.047	0.154	0.161
178.	RMC QPSK 20MHz 50%RB	Front Side	1720.0	23.30	23.5	1.047	0.132	0.138

LTE Band 5–Body SAR Test (Gap: 10mm)								
Plot No.	Mode	Test Position Body	Frequency	Output Power (dBm)	Rated Limit (dBm)	Scaling Factor	SAR1g (W/kg)	Scaled SAR1g (W/kg)
	Modulation, Bandwidth, RB		MHz					
179.	RMC QPSK 10MHz 1RB	Back Side	829.0	23.45	23.5	1.012	0.032	0.032
180.	RMC QPSK 10MHz 1RB	Front Side	829.0	23.45	23.5	1.012	0.007	0.007
181.	RMC QPSK 10MHz 50%RB	Back Side	829.0	23.45	23.5	1.012	0.018	0.018
182.	RMC QPSK 10MHz 50%RB	Front Side	829.0	23.45	23.5	1.012	0.004	0.004

LTE Band 7–Body SAR Test (Gap: 10mm)								
Plot No.	Mode	Test Position Body	Frequency	Output Power (dBm)	Rated Limit (dBm)	Scaling Factor	SAR1g (W/kg)	Scaled SAR1g (W/kg)
	Modulation, Bandwidth, RB		MHz					
183.	RMC QPSK 20MHz 1RB	Back Side	2560.0	23.28	23.5	1.052	1.008	1.060
184.	RMC QPSK 20MHz 1RB	Back Side	2510.0	23.17	23.5	1.079	0.914	0.986
185.	RMC QPSK 20MHz 1RB	Back Side	2535.0	23.25	23.5	1.059	1.032	1.093
186.	RMC QPSK 20MHz 1RB	Front Side	2560.0	23.28	23.5	1.052	0.663	0.697
187.	RMC QPSK 20MHz 50%RB	Back Side	2560.0	23.28	23.5	1.052	0.511	0.538
188.	RMC QPSK 20MHz 50%RB	Front Side	2560.0	23.28	23.5	1.052	0.323	0.340

LTE Band 12–Body SAR Test (Gap: 10mm)								
Plot No.	Mode	Test Position Body	Frequency	Output Power (dBm)	Rated Limit (dBm)	Scaling Factor	SAR1g (W/kg)	Scaled SAR1g (W/kg)
	Modulation, Bandwidth, RB		MHz					
189.	RMC QPSK 10MHz 1RB	Back Side	707.5	22.91	23.0	1.021	0.041	0.042
190.	RMC QPSK 10MHz 1RB	Front Side	707.5	22.91	23.0	1.021	0.022	0.022
191.	RMC QPSK 10MHz 50%RB	Back Side	707.5	22.91	23.0	1.021	0.023	0.023
192.	RMC QPSK 10MHz 50%RB	Front Side	707.5	22.91	23.0	1.021	0.014	0.014

LTE Band 13–Body SAR Test (Gap: 10mm)								
Plot No.	Mode	Test Position Body	Frequency	Output Power (dBm)	Rated Limit (dBm)	Scaling Factor	SAR1g (W/kg)	Scaled SAR1g (W/kg)
	Modulation, Bandwidth, RB		MHz					
193.	RMC QPSK 10MHz 1RB	Back Side	782.0	24.11	24.5	1.094	0.032	0.035
194.	RMC QPSK 10MHz 1RB	Front Side	782.0	24.11	24.5	1.094	0.006	0.007
195.	RMC QPSK 10MHz 50%RB	Back Side	782.0	24.11	24.5	1.094	0.019	0.021
196.	RMC QPSK 10MHz 50%RB	Front Side	782.0	24.11	24.5	1.094	0.004	0.004

LTE Band 17–Body SAR Test (Gap: 10mm)								
Plot No.	Mode	Test Position Body	Frequency	Output Power (dBm)	Rated Limit (dBm)	Scaling Factor	SAR1g (W/kg)	Scaled SAR1g (W/kg)
	Modulation, Bandwidth, RB		MHz					
197.	RMC QPSK 5MHz 1RB	Back Side	713.5	23.34	23.5	1.038	0.035	0.036
198.	RMC QPSK 5MHz 1RB	Front Side	713.5	23.34	23.5	1.038	0.020	0.021
199.	RMC QPSK 5MHz 50%RB	Back Side	713.5	23.34	23.5	1.038	0.018	0.019
200.	RMC QPSK 5MHz 50%RB	Front Side	713.5	23.34	23.5	1.038	0.012	0.012

LTE Band 25–Body SAR Test (Gap: 10mm)								
Plot No.	Mode	Test Position Body	Frequency	Output Power (dBm)	Rated Limit (dBm)	Scaling Factor	SAR1g (W/kg)	Scaled SAR1g (W/kg)
	Modulation, Bandwidth, RB		MHz					
201.	RMC QPSK 10MHz 1RB	Back Side	1855.0	22.48	22.5	1.005	0.579	0.582
202.	RMC QPSK 10MHz 1RB	Front Side	1855.0	22.48	22.5	1.005	0.412	0.414
203.	RMC QPSK 10MHz 50%RB	Back Side	1855.0	22.48	22.5	1.005	0.309	0.310
204.	RMC QPSK 10MHz 50%RB	Front Side	1855.0	22.48	22.5	1.005	0.227	0.228

LTE Band 26–Body SAR Test (Gap: 10mm)								
Plot No.	Mode	Test Position Body	Freque ncy	Output Power (dBm)	Rated Limit (dBm)	Scaling Factor	SAR1g (W/kg)	Scaled SAR1g (W/kg)
	Modulation, Bandwidth, RB		MHz					
205.	RMC QPSK 10MHz 1RB	Back Side	831.0	23.59	24.0	1.099	0.052	0.057
206.	RMC QPSK 10MHz 1RB	Front Side	831.0	23.59	24.0	1.099	0.012	0.013
207.	RMC QPSK 10MHz 50%RB	Back Side	831.0	23.59	24.0	1.099	0.033	0.036
208.	RMC QPSK 10MHz 50%RB	Front Side	831.0	23.59	24.0	1.099	0.007	0.008

LTE Band 30–Body SAR Test (Gap: 10mm)								
Plot No.	Mode	Test Position Body	Freque ncy	Output Power (dBm)	Rated Limit (dBm)	Scaling Factor	SAR1g (W/kg)	Scaled SAR1g (W/kg)
	Modulation, Bandwidth, RB		MHz					
209.	RMC QPSK 20MHz 1RB	Back Side	2310.0	23.89	24.0	1.026	0.348	0.357
210.	RMC QPSK 20MHz 1RB	Front Side	2310.0	23.89	24.0	1.026	0.323	0.331
211.	RMC QPSK 20MHz 50%RB	Back Side	2310.0	23.89	24.0	1.026	0.167	0.171
212.	RMC QPSK 20MHz 50%RB	Front Side	2310.0	23.89	24.0	1.026	0.153	0.157

LTE Band 40:2305-2315MHz–Body SAR Test (Gap: 10mm)								
Plot No.	Mode	Test Position Body	Freque ncy	Output Power (dBm)	Rated Limit (dBm)	Scaling Factor	SAR1g (W/kg)	Scaled SAR1g (W/kg)
	Modulation, Bandwidth, RB		MHz					
213.	RMC QPSK 10MHz 1RB	Back Side	2310.0	22.86	23.0	1.033	0.117	0.121
214.	RMC QPSK 10MHz 1RB	Front Side	2310.0	22.86	23.0	1.033	0.101	0.104
215.	RMC QPSK 10MHz 50%RB	Back Side	2310.0	22.86	23.0	1.033	0.065	0.067
216.	RMC QPSK 10MHz 50%RB	Front Side	2310.0	22.86	23.0	1.033	0.061	0.063

LTE Band 40: 2350-2360MHz–Body SAR Test (Gap: 10mm)								
Plot No.	Mode	Test Position Body	Freque ncy	Output Power (dBm)	Rated Limit (dBm)	Scaling Factor	SAR1g (W/kg)	Scaled SAR1g (W/kg)
	Modulation, Bandwidth, RB		MHz					
217.	RMC QPSK 10MHz 1RB	Back Side	2355.0	22.97	23.0	1.007	0.125	0.126
218.	RMC QPSK 10MHz 1RB	Front Side	2355.0	22.97	23.0	1.007	0.091	0.092
219.	RMC QPSK 10MHz 50%RB	Back Side	2355.0	22.97	23.0	1.007	0.067	0.067
220.	RMC QPSK 10MHz 50%RB	Front Side	2355.0	22.97	23.0	1.007	0.045	0.045

LTE Band 66–Body SAR Test (Gap: 10mm)								
Plot No.	Mode	Test Position Body	Frequency	Output Power (dBm)	Rated Limit (dBm)	Scaling Factor	SAR1g (W/kg)	Scaled SAR1g (W/kg)
	Modulation, Bandwidth, RB		MHz					
221.	RMC QPSK 20MHz 1RB	Back Side	1712.5	25.47	25.5	1.007	0.582	0.586
222.	RMC QPSK 20MHz 1RB	Front Side	1712.5	25.47	25.5	1.007	0.398	0.401
223.	RMC QPSK 20MHz 50%RB	Back Side	1712.5	25.47	25.5	1.007	0.288	0.290
224.	RMC QPSK 20MHz 50%RB	Front Side	1712.5	25.47	25.5	1.007	0.159	0.160

WLAN 2.4GHz –Body SAR Test									
Plot No.	Mode	Test Position Body	Frequency		Output Power (dBm)	Rated Limit (dBm)	Scaling Factor	SAR1g (W/kg)	Scaled SAR1g (W/kg)
			CH.	MHz					
225.	802.11b	Back Side	11	2462	17.52	18.0	1.117	0.153	0.171
226.	802.11b	Front Side	11	2462	17.52	18.0	1.117	0.088	0.098

WLAN 5.2GHz –Body SAR Test									
Plot No.	Mode	Test Position Body	Frequency		Output Power (dBm)	Rated Limit (dBm)	Scaling Factor	SAR1g (W/kg)	Scaled SAR1g (W/kg)
			CH.	MHz					
227.	802.11n-20	Back Side	48	5240	14.74	15.0	1.062	0.103	0.109
228.	802.11n-20	Front Side	48	5240	14.74	15.0	1.062	0.054	0.057

WLAN 5.3GHz –Body SAR Test									
Plot No.	Mode	Test Position Body	Frequency		Output Power (dBm)	Rated Limit (dBm)	Scaling Factor	SAR1g (W/kg)	Scaled SAR1g (W/kg)
			CH.	MHz					
229.	802.11n-20	Back Side	54	5270	10.99	11.0	1.002	0.189	0.189
230.	802.11n-20	Front Side	54	5270	10.99	11.0	1.002	0.106	0.106

WLAN 5.6GHz –Body SAR Test									
Plot No.	Mode	Test Position Body	Frequency		Output Power (dBm)	Rated Limit (dBm)	Scaling Factor	SAR1g (W/kg)	Scaled SAR1g (W/kg)
			CH.	MHz					
231.	802.11n-20	Back Side	100	5500	11.82	12.0	1.042	0.358	0.373
232.	802.11n-20	Front Side	100	5500	11.82	12.0	1.042	0.133	0.139

WLAN 5.8GHz –Body SAR Test									
Plot No.	Mode	Test Position Body	Frequency		Output Power (dBm)	Rated Limit (dBm)	Scaling Factor	SAR1g (W/kg)	Scaled SAR1g (W/kg)
			CH.	MHz					
233.	802.11n-20	Back Side	165	5825	13.79	14.0	1.050	0.215	0.226
234.	802.11n-20	Front Side	165	5825	13.79	14.0	1.050	0.123	0.129

Remark: Per KDB 447498 D01 v06, if the highest output channel SAR for each exposure position ≤ 0.8 W/kg other channels SAR tests are not necessary.

Hotspot SAR

GSM850 – Body SAR Test (Gap: 10mm)									
Plot No.	Mode	Test Position Body	Frequency		Output Power (dBm)	Rated Limit (dBm)	Scaling Factor	SAR1g (W/kg)	Scaled SAR1g (W/kg)
			CH.	MHz					
235.	GPRS_4TX	Back Side	128	824.2	29.59	30.0	1.099	1.165	1.280
236.	GPRS_4TX	Back Side	190	836.6	29.44	30.0	1.138	0.997	1.134
237.	GPRS_4TX	Back Side	251	848.8	29.57	30.0	1.104	0.387	0.427
238.	GPRS_4TX	Front Side	128	824.2	29.59	30.0	1.099	0.937	1.030
239.	GPRS_4TX	Front Side	190	836.6	29.44	30.0	1.138	0.799	0.909
240.	GPRS_4TX	Front Side	251	848.8	29.57	30.0	1.104	0.629	0.694
241.	GPRS_4TX	Right side	128	824.2	29.59	30.0	1.099	0.113	0.124
242.	GPRS_4TX	Left side	128	824.2	29.59	30.0	1.099	0.101	0.111
243.	GPRS_4TX	Bottom side	128	824.2	29.59	30.0	1.099	0.073	0.080

GSM1900 – Body SAR Test (Gap: 10mm)									
Plot No.	Mode	Test Position Body	Frequency		Output Power (dBm)	Rated Limit (dBm)	Scaling Factor	SAR1g (W/kg)	Scaled SAR1g (W/kg)
			CH.	MHz					
244.	GPRS_2TX	Back Side	810	1909.8	29.22	30.0	1.197	1.070	1.281
245.	GPRS_2TX	Back Side	512	1850.2	29.67	30.0	1.079	1.126	1.215
246.	GPRS_2TX	Back Side	661	1880.0	29.75	30.0	1.059	1.093	1.158
247.	GPRS_2TX	Front Side	810	1909.8	29.22	30.0	1.197	0.883	1.057
248.	GPRS_2TX	Front Side	512	1850.2	29.67	30.0	1.079	0.820	0.885
249.	GPRS_2TX	Front Side	661	1880.0	29.75	30.0	1.059	0.900	0.953
250.	GPRS_2TX	Right side	810	1909.8	29.22	30.0	1.197	0.511	0.612
251.	GPRS_2TX	Left side	810	1909.8	29.22	30.0	1.197	0.492	0.589
252.	GPRS_2TX	Bottom side	810	1909.8	29.22	30.0	1.197	0.816	0.977
253.	GPRS_2TX	Bottom side	512	1850.2	29.67	30.0	1.079	0.707	0.763
254.	GPRS_2TX	Bottom side	661	1880.0	29.75	30.0	1.059	0.791	0.838

WCDMA Band 2 – Body SAR Test (Gap: 10mm)									
Plot No.	Mode	Test Position Body	Frequency		Output Power (dBm)	Rated Limit (dBm)	Scaling Factor	SAR1g (W/kg)	Scaled SAR1g (W/kg)
			CH.	MHz					
255.	RMC 12.2k	Back Side	9538	1907.6	22.29	22.5	1.050	0.809	0.849
256.	RMC 12.2k	Back Side	9262	1852.4	22.09	22.5	1.099	0.842	0.925
257.	RMC 12.2k	Back Side	9400	1880.0	22.14	22.5	1.086	0.846	0.919
258.	RMC 12.2k	Front Side	9538	1907.6	22.29	22.5	1.050	0.745	0.782
259.	RMC 12.2k	Right side	9538	1907.6	22.29	22.5	1.050	0.336	0.353
260.	RMC 12.2k	Left side	9262	1852.4	22.29	22.5	1.050	0.315	0.331
261.	RMC 12.2k	Bottom side	9400	1880.0	22.29	22.5	1.050	0.689	0.723

WCDMA Band 5 – Body SAR Test (Gap: 10mm)									
Plot No.	Mode	Test Position Body	Frequency		Output Power (dBm)	Rated Limit (dBm)	Scaling Factor	SAR1g (W/kg)	Scaled SAR1g (W/kg)
			CH.	MHz					
262.	RMC 12.2k	Back Side	4183	836.6	22.45	22.5	1.012	0.271	0.274
263.	RMC 12.2k	Front Side	4183	836.6	22.45	22.5	1.012	0.212	0.214
264.	RMC 12.2k	Right side	4183	836.6	22.45	22.5	1.012	0.065	0.066
265.	RMC 12.2k	Left side	4183	836.6	22.45	22.5	1.012	0.053	0.054
266.	RMC 12.2k	Bottom side	4183	836.6	22.45	22.5	1.012	0.022	0.022

WCDMA Band 4 – Body SAR Test (Gap: 10mm)									
Plot No.	Mode	Test Position Body	Frequency		Output Power (dBm)	Rated Limit (dBm)	Scaling Factor	SAR1g (W/kg)	Scaled SAR1g (W/kg)
			CH.	MHz					
267.	RMC 12.2k	Back Side	1513	1752.6	21.36	21.5	1.033	1.078	1.113
268.	RMC 12.2k	Back Side	1312	1712.4	21.22	21.5	1.067	1.035	1.104
269.	RMC 12.2k	Back Side	1412	1732.4	21.27	21.5	1.054	1.051	1.108
270.	RMC 12.2k	Front Side	1513	1752.6	21.36	21.5	1.033	0.719	0.743
271.	RMC 12.2k	Right side	1513	1752.6	21.36	21.5	1.033	0.441	0.455
272.	RMC 12.2k	Left side	1513	1752.6	21.36	21.5	1.033	0.432	0.446
273.	RMC 12.2k	Bottom side	1513	1752.6	21.36	21.5	1.033	0.826	0.853
274.	RMC 12.2k	Bottom side	1312	1712.4	21.22	21.5	1.067	0.901	0.961
275.	RMC 12.2k	Bottom side	1412	1732.4	21.27	21.5	1.054	0.831	0.876

LTE Band 2–Body SAR Test (Gap: 10mm)								
Plot No.	Mode	Test Position Body	Freque ncy	Output Power (dBm)	Rated Limit (dBm)	Scali ng Facto r	SAR1g (W/kg)	Scaled SAR1g (W/kg)
	Modulation, Bandwidth, RB		MHz					
276.	RMC QPSK 20MHz 1RB	Back Side	1860.0	22.77	23.0	1.054	0.469	0.495
277.	RMC QPSK 20MHz 1RB	Front Side	1860.0	22.77	23.0	1.054	0.384	0.405
278.	RMC QPSK 20MHz 1RB	Right side	1860.0	22.77	23.0	1.054	0.212	0.224
279.	RMC QPSK 20MHz 1RB	Left side	1860.0	22.77	23.0	1.054	0.189	0.199
280.	RMC QPSK 20MHz 1RB	Bottom side	1860.0	22.77	23.0	1.054	0.942	0.993
281.	RMC QPSK 20MHz 1RB	Bottom side	1880.0	22.74	23.0	1.062	0.970	1.030
282.	RMC QPSK 20MHz 1RB	Bottom side	1900.0	22.64	23.0	1.086	0.954	1.036
283.	RMC QPSK 20MHz 50%RB	Back Side	1860.0	22.77	23.0	1.054	0.233	0.246
284.	RMC QPSK 20MHz 50%RB	Front Side	1860.0	22.77	23.0	1.054	0.156	0.164
285.	RMC QPSK 20MHz 50%RB	Right side	1860.0	22.77	23.0	1.054	0.117	0.123
286.	RMC QPSK 20MHz 50%RB	Left side	1860.0	22.77	23.0	1.054	0.102	0.108
287.	RMC QPSK 20MHz 50%RB	Bottom side	1860.0	22.77	23.0	1.054	0.447	0.471
288.	RMC QPSK 20MHz 100%RB	Bottom side	1860.0	22.77	23.0	1.054	0.453	0.478

LTE Band 4–Body SAR Test (Gap: 10mm)								
Plot No.	Mode	Test Position Body	Freque ncy	Outp ut Powe r (dBm)	Rated Limit (dBm)	Scaling Factor	SAR1g (W/kg)	Scaled SAR1g (W/kg)
	Modulation, Bandwidth, RB		MHz					
289.	RMC QPSK 20MHz 1RB	Back Side	1720.0	23.30	23.5	1.047	0.382	0.400
290.	RMC QPSK 20MHz 1RB	Front Side	1720.0	23.30	23.5	1.047	0.317	0.332
291.	RMC QPSK 20MHz 1RB	Right side	1720.0	23.30	23.5	1.047	0.159	0.166
292.	RMC QPSK 20MHz 1RB	Left side	1720.0	23.30	23.5	1.047	0.155	0.162
293.	RMC QPSK 20MHz 1RB	Bottom side	1720.0	23.30	23.5	1.047	0.698	0.731
294.	RMC QPSK 20MHz 50%RB	Back Side	1720.0	23.30	23.5	1.047	0.154	0.161
295.	RMC QPSK 20MHz 50%RB	Front Side	1720.0	23.30	23.5	1.047	0.132	0.138
296.	RMC QPSK 20MHz 50%RB	Right side	1720.0	23.30	23.5	1.047	0.078	0.082
297.	RMC QPSK 20MHz 50%RB	Left side	1720.0	23.30	23.5	1.047	0.069	0.072
298.	RMC QPSK 20MHz 50%RB	Bottom side	1720.0	23.30	23.5	1.047	0.339	0.355

LTE Band 5–Body SAR Test (Gap: 10mm)								
Plot No.	Mode	Test Position Body	Frequency	Output Power (dBm)	Rated Limit (dBm)	Scaling Factor	SAR1g (W/kg)	Scaled SAR1g (W/kg)
	Modulation, Bandwidth, RB		MHz					
299.	RMC QPSK 10MHz 1RB	Back Side	829.0	23.45	23.5	1.012	0.032	0.032
300.	RMC QPSK 10MHz 1RB	Front Side	829.0	23.45	23.5	1.012	0.007	0.007
301.	RMC QPSK 10MHz 1RB	Right side	829.0	23.45	23.5	1.012	0.005	0.005
302.	RMC QPSK 10MHz 1RB	Left side	829.0	23.45	23.5	1.012	0.004	0.004
303.	RMC QPSK 10MHz 1RB	Bottom side	829.0	23.45	23.5	1.012	0.012	0.012
304.	RMC QPSK 10MHz 50%RB	Back Side	829.0	23.45	23.5	1.012	0.018	0.018
305.	RMC QPSK 10MHz 50%RB	Front Side	829.0	23.45	23.5	1.012	0.004	0.004
306.	RMC QPSK 10MHz 50%RB	Right side	829.0	23.45	23.5	1.012	0.003	0.003
307.	RMC QPSK 10MHz 50%RB	Left side	829.0	23.45	23.5	1.012	0.002	0.002
308.	RMC QPSK 10MHz 50%RB	Bottom side	829.0	23.45	23.5	1.012	0.007	0.007

LTE Band 7–Body SAR Test (Gap: 10mm)								
Plot No.	Mode	Test Position Body	Frequency	Output Power (dBm)	Rated Limit (dBm)	Scaling Factor	SAR1g (W/kg)	Scaled SAR1g (W/kg)
	Modulation, Bandwidth, RB		MHz					
309.	RMC QPSK 20MHz 1RB	Back Side	2560.0	23.28	23.5	1.052	1.008	1.060
310.	RMC QPSK 20MHz 1RB	Back Side	2510.0	23.17	23.5	1.079	0.914	0.986
311.	RMC QPSK 20MHz 1RB	Back Side	2535.0	23.25	23.5	1.059	1.032	1.093
312.	RMC QPSK 20MHz 1RB	Front Side	2560.0	23.28	23.5	1.052	0.663	0.697
313.	RMC QPSK 20MHz 1RB	Right side	2560.0	23.28	23.5	1.052	0.355	0.373
314.	RMC QPSK 20MHz 1RB	Left side	2560.0	23.28	23.5	1.052	0.336	0.353
315.	RMC QPSK 20MHz 1RB	Bottom side	2560.0	23.28	23.5	1.052	0.539	0.567
316.	RMC QPSK 20MHz 50%RB	Back Side	2560.0	23.28	23.5	1.052	0.511	0.538
317.	RMC QPSK 20MHz 50%RB	Front Side	2560.0	23.28	23.5	1.052	0.323	0.340
318.	RMC QPSK 20MHz 50%RB	Right side	2560.0	23.28	23.5	1.052	0.188	0.198
319.	RMC QPSK 20MHz 50%RB	Left side	2560.0	23.28	23.5	1.052	0.182	0.191
320.	RMC QPSK 20MHz 50%RB	Bottom side	2560.0	23.28	23.5	1.052	0.222	0.234
321.	RMC QPSK 20MHz 100%RB	Back Side	2560.0	23.28	23.5	1.052	0.521	0.548

LTE Band 12–Body SAR Test (Gap: 10mm)								
Plot No.	Mode	Test Position Body	Frequency	Output Power	Rated Limit (dBm)	Scaling Factor	SAR1g (W/kg)	Scaled SAR1g (W/kg)
	Modulation, Bandwidth, RB		MHz	(dBm)				
322.	RMC QPSK 10MHz 1RB	Back Side	707.5	22.91	23.0	1.021	0.041	0.042
323.	RMC QPSK 10MHz 1RB	Front Side	707.5	22.91	23.0	1.021	0.022	0.022
324.	RMC QPSK 10MHz 1RB	Right side	707.5	22.91	23.0	1.021	0.012	0.012
325.	RMC QPSK 10MHz 1RB	Left side	707.5	22.91	23.0	1.021	0.011	0.011
326.	RMC QPSK 10MHz 1RB	Bottom side	707.5	22.91	23.0	1.021	0.010	0.010
327.	RMC QPSK 10MHz 50%RB	Back Side	707.5	22.91	23.0	1.021	0.023	0.023
328.	RMC QPSK 10MHz 50%RB	Front Side	707.5	22.91	23.0	1.021	0.014	0.014
329.	RMC QPSK 10MHz 50%RB	Right side	707.5	22.91	23.0	1.021	0.007	0.007
330.	RMC QPSK 10MHz 50%RB	Left side	707.5	22.91	23.0	1.021	0.006	0.006
331.	RMC QPSK 10MHz 50%RB	Bottom side	707.5	22.91	23.0	1.021	0.006	0.006

LTE Band 13–Body SAR Test (Gap: 10mm)								
Plot No.	Mode	Test Position Body	Frequency	Output Power	Rated Limit (dBm)	Scaling Factor	SAR1g (W/kg)	Scaled SAR1g (W/kg)
	Modulation, Bandwidth, RB		MHz	(dBm)				
332.	RMC QPSK 10MHz 1RB	Back Side	782.0	24.11	24.5	1.094	0.032	0.035
333.	RMC QPSK 10MHz 1RB	Front Side	782.0	24.11	24.5	1.094	0.006	0.007
334.	RMC QPSK 10MHz 1RB	Right side	782.0	24.11	24.5	1.094	0.018	0.020
335.	RMC QPSK 10MHz 1RB	Left side	782.0	24.11	24.5	1.094	0.016	0.018
336.	RMC QPSK 10MHz 1RB	Bottom side	782.0	24.11	24.5	1.094	0.011	0.012
337.	RMC QPSK 10MHz 50%RB	Back Side	782.0	24.11	24.5	1.094	0.019	0.021
338.	RMC QPSK 10MHz 50%RB	Front Side	782.0	24.11	24.5	1.094	0.004	0.004
339.	RMC QPSK 10MHz 50%RB	Right side	782.0	24.11	24.5	1.094	0.010	0.011
340.	RMC QPSK 10MHz 50%RB	Left side	782.0	24.11	24.5	1.094	0.009	0.010
341.	RMC QPSK 10MHz 50%RB	Bottom side	782.0	24.11	24.5	1.094	0.006	0.007

LTE Band 17–Body SAR Test (Gap: 10mm)								
Plot No.	Mode	Test Position Body	Frequency	Output Power (dBm)	Rated Limit (dBm)	Scaling Factor	SAR1g (W/kg)	Scaled SAR1g (W/kg)
	Modulation, Bandwidth, RB		MHz					
342.	RMC QPSK 5MHz 1RB	Back Side	713.5	23.34	23.5	1.038	0.035	0.036
343.	RMC QPSK 5MHz 1RB	Front Side	713.5	23.34	23.5	1.038	0.020	0.021
344.	RMC QPSK 5MHz 1RB	Right side	713.5	23.34	23.5	1.038	0.019	0.020
345.	RMC QPSK 5MHz 1RB	Left side	713.5	23.34	23.5	1.038	0.017	0.018
346.	RMC QPSK 5MHz 1RB	Bottom side	713.5	23.34	23.5	1.038	0.009	0.009
347.	RMC QPSK 5MHz 50%RB	Back Side	713.5	23.34	23.5	1.038	0.018	0.019
348.	RMC QPSK 5MHz 50%RB	Front Side	713.5	23.34	23.5	1.038	0.012	0.012
349.	RMC QPSK 5MHz 50%RB	Right side	713.5	23.34	23.5	1.038	0.011	0.011
350.	RMC QPSK 5MHz 50%RB	Left side	713.5	23.34	23.5	1.038	0.010	0.010
351.	RMC QPSK 5MHz 50%RB	Bottom side	713.5	23.34	23.5	1.038	0.005	0.005

LTE Band 25–Body SAR Test (Gap: 10mm)								
Plot No.	Mode	Test Position Body	Frequency	Output Power (dBm)	Rated Limit (dBm)	Scaling Factor	SAR1g (W/kg)	Scaled SAR1g (W/kg)
	Modulation, Bandwidth, RB		MHz					
352.	RMC QPSK 10MHz 1RB	Back Side	1855.0	22.48	22.5	1.005	0.579	0.582
353.	RMC QPSK 10MHz 1RB	Front Side	1855.0	22.48	22.5	1.005	0.412	0.414
354.	RMC QPSK 10MHz 1RB	Right side	1855.0	22.48	22.5	1.005	0.331	0.333
355.	RMC QPSK 10MHz 1RB	Left side	1855.0	22.48	22.5	1.005	0.318	0.319
356.	RMC QPSK 10MHz 1RB	Bottom side	1855.0	22.48	22.5	1.005	0.962	0.966
357.	RMC QPSK 10MHz 1RB	Bottom side	1882.5	22.38	22.5	1.028	0.946	0.973
358.	RMC QPSK 10MHz 1RB	Bottom side	1910.0	22.36	22.5	1.033	0.966	0.998
359.	RMC QPSK 10MHz 50%RB	Back Side	1855.0	22.48	22.5	1.005	0.309	0.310
360.	RMC QPSK 10MHz 50%RB	Front Side	1855.0	22.48	22.5	1.005	0.227	0.228
361.	RMC QPSK 10MHz 50%RB	Right side	1855.0	22.48	22.5	1.005	0.161	0.162
362.	RMC QPSK 10MHz 50%RB	Left side	1855.0	22.48	22.5	1.005	0.158	0.159
363.	RMC QPSK 10MHz 50%RB	Bottom side	1855.0	22.48	22.5	1.005	0.455	0.457
364.	RMC QPSK 10MHz 50%RB	Bottom side	1855.0	22.48	22.5	1.005	0.461	0.463

LTE Band 26–Body SAR Test (Gap: 10mm)								
Plot No.	Mode	Test Position Body	Freque ncy	Output Power (dBm)	Rated Limit (dBm)	Scali ng Facto r	SAR1g (W/kg)	Scaled SAR1g (W/kg)
	Modulation, Bandwidth, RB		MHz					
365.	RMC QPSK 10MHz 1RB	Back Side	831.0	23.59	24.0	1.099	0.052	0.057
366.	RMC QPSK 10MHz 1RB	Front Side	831.0	23.59	24.0	1.099	0.012	0.013
367.	RMC QPSK 10MHz 1RB	Right side	831.0	23.59	24.0	1.099	0.013	0.014
368.	RMC QPSK 10MHz 1RB	Left side	831.0	23.59	24.0	1.099	0.011	0.012
369.	RMC QPSK 10MHz 1RB	Bottom side	831.0	23.59	24.0	1.099	0.023	0.025
370.	RMC QPSK 10MHz 50%RB	Back Side	831.0	23.59	24.0	1.099	0.033	0.036
371.	RMC QPSK 10MHz 50%RB	Front Side	831.0	23.59	24.0	1.099	0.007	0.008
372.	RMC QPSK 10MHz 50%RB	Right side	831.0	23.59	24.0	1.099	0.006	0.007
373.	RMC QPSK 10MHz 50%RB	Left side	831.0	23.59	24.0	1.099	0.006	0.007
374.	RMC QPSK 10MHz 50%RB	Bottom side	831.0	23.59	24.0	1.099	0.012	0.013

LTE Band 30–Body SAR Test (Gap: 10mm)								
Plot No.	Mode	Test Position Body	Freque ncy	Output Power (dBm)	Rated Limit (dBm)	Scali ng Facto r	SAR1g (W/kg)	Scaled SAR1g (W/kg)
	Modulation, Bandwidth, RB		MHz					
375.	RMC QPSK 10MHz 1RB	Back Side	2310.0	23.89	24.0	1.026	0.348	0.357
376.	RMC QPSK 10MHz 1RB	Front Side	2310.0	23.89	24.0	1.026	0.323	0.331
377.	RMC QPSK 10MHz 1RB	Right side	2310.0	23.89	24.0	1.026	0.211	0.216
378.	RMC QPSK 10MHz 1RB	Left side	2310.0	23.89	24.0	1.026	0.199	0.204
379.	RMC QPSK 10MHz 1RB	Bottom side	2310.0	23.89	24.0	1.026	0.321	0.329
380.	RMC QPSK 10MHz 50%RB	Back Side	2310.0	23.89	24.0	1.026	0.167	0.171
381.	RMC QPSK 10MHz 50%RB	Front Side	2310.0	23.89	24.0	1.026	0.153	0.157
382.	RMC QPSK 10MHz 50%RB	Right side	2310.0	23.89	24.0	1.026	0.122	0.125
383.	RMC QPSK 10MHz 50%RB	Left side	2310.0	23.89	24.0	1.026	0.109	0.112
384.	RMC QPSK 10MHz 50%RB	Bottom side	2310.0	23.89	24.0	1.026	0.166	0.170

LTE Band 40:2305-2315MHz–Body SAR Test (Gap: 10mm)								
Plot No.	Mode	Test Position Body	Frequency	Output Power (dBm)	Rated Limit (dBm)	Scaling Factor	SAR1g (W/kg)	Scaled SAR1g (W/kg)
	Modulation, Bandwidth, RB		MHz					
385.	RMC QPSK 10MHz 1RB	Back Side	2310.0	22.86	23.0	1.033	0.117	0.121
386.	RMC QPSK 10MHz 1RB	Front Side	2310.0	22.86	23.0	1.033	0.101	0.104
387.	RMC QPSK 10MHz 1RB	Right side	2310.0	22.86	23.0	1.033	0.087	0.090
388.	RMC QPSK 10MHz 1RB	Left side	2310.0	22.86	23.0	1.033	0.082	0.085
389.	RMC QPSK 10MHz 1RB	Bottom side	2310.0	22.86	23.0	1.033	0.102	0.105
390.	RMC QPSK 10MHz 50%RB	Back Side	2310.0	22.86	23.0	1.033	0.065	0.067
391.	RMC QPSK 10MHz 50%RB	Front Side	2310.0	22.86	23.0	1.033	0.061	0.063
392.	RMC QPSK 10MHz 50%RB	Right side	2310.0	22.86	23.0	1.033	0.047	0.049
393.	RMC QPSK 10MHz 50%RB	Left side	2310.0	22.86	23.0	1.033	0.046	0.048
394.	RMC QPSK 10MHz 50%RB	Bottom side	2310.0	22.86	23.0	1.033	0.051	0.053

LTE Band 40: 2350-2360MHz–Body SAR Test (Gap: 10mm)								
Plot No.	Mode	Test Position Body	Frequency	Output Power (dBm)	Rated Limit (dBm)	Scaling Factor	SAR1g (W/kg)	Scaled SAR1g (W/kg)
	Modulation, Bandwidth, RB		MHz					
395.	RMC QPSK 10MHz 1RB	Back Side	2355.0	22.97	23.0	1.007	0.125	0.126
396.	RMC QPSK 10MHz 1RB	Front Side	2355.0	22.97	23.0	1.007	0.091	0.092
397.	RMC QPSK 10MHz 1RB	Right side	2355.0	22.97	23.0	1.007	0.087	0.088
398.	RMC QPSK 10MHz 1RB	Left side	2355.0	22.97	23.0	1.007	0.082	0.083
399.	RMC QPSK 10MHz 1RB	Bottom side	2355.0	22.97	23.0	1.007	0.119	0.120
400.	RMC QPSK 10MHz 50%RB	Back Side	2355.0	22.97	23.0	1.007	0.067	0.067
401.	RMC QPSK 10MHz 50%RB	Front Side	2355.0	22.97	23.0	1.007	0.045	0.045
402.	RMC QPSK 10MHz 50%RB	Right side	2355.0	22.97	23.0	1.007	0.047	0.047
403.	RMC QPSK 10MHz 50%RB	Left side	2355.0	22.97	23.0	1.007	0.044	0.044
404.	RMC QPSK 10MHz 50%RB	Bottom side	2355.0	22.97	23.0	1.007	0.059	0.059

LTE Band 66:Body SAR Test (Gap: 10mm)								
Plot No.	Mode	Test Position Body	Frequency	Output Power (dBm)	Rated Limit (dBm)	Scaling Factor	SAR1g (W/kg)	Scaled SAR1g (W/kg)
	Modulation, Bandwidth, RB		MHz					
405.	RMC QPSK 5MHz 1RB	Back Side	1712.5	25.47	25.5	1.007	0.582	0.586
406.	RMC QPSK 5MHz 1RB	Front Side	1712.5	25.47	25.5	1.007	0.398	0.401
407.	RMC QPSK 5MHz 1RB	Right side	1712.5	25.47	25.5	1.007	0.311	0.313
408.	RMC QPSK 5MHz 1RB	Left side	1712.5	25.47	25.5	1.007	0.289	0.291
409.	RMC QPSK 5MHz 1RB	Bottom side	1712.5	25.47	25.5	1.007	0.823	0.829
410.	RMC QPSK 5MHz 1RB	Bottom side	1755.0	25.37	25.5	1.030	0.781	0.805
411.	RMC QPSK 5MHz 1RB	Bottom side	1777.5	25.39	25.5	1.026	0.831	0.852
412.	RMC QPSK 5MHz 50%RB	Back Side	1712.5	25.47	25.5	1.007	0.288	0.290

413.	RMC QPSK 5MHz 50%RB	Front Side	1712.5	25.47	25.5	1.007	0.159	0.160
414.	RMC QPSK 5MHz 50%RB	Right side	1712.5	25.47	25.5	1.007	0.155	0.156
415.	RMC QPSK 5MHz 50%RB	Left side	1712.5	25.47	25.5	1.007	0.151	0.152
416.	RMC QPSK 5MHz 50%RB	Bottom side	1712.5	25.47	25.5	1.007	0.421	0.424
417.	RMC QPSK 5MHz 100%RB	Bottom side	1712.5	25.47	25.5	1.007	0.432	0.435

WLAN 2.4GHz –Body SAR Test

Plot No.	Mode	Test Position Body	Frequency		Output Power (dBm)	Rated Limit (dBm)	Scaling Factor	SAR1g (W/kg)	Scaled SAR1g (W/kg)
			CH.	MHz					
418.	802.11b	Back Side	11	2462	17.52	18.0	1.117	0.153	0.171
419.	802.11b	Front Side	11	2462	17.52	18.0	1.117	0.088	0.098
420.	802.11b	Left side	11	2462	17.52	18.0	1.117	0.090	0.101
421.	802.11b	Top side	11	2462	17.52	18.0	1.117	0.086	0.096

WLAN 5.2GHz –Body SAR Test

Plot No.	Mode	Test Position Body	Frequency		Output Power (dBm)	Rated Limit (dBm)	Scaling Factor	SAR1g (W/kg)	Scaled SAR1g (W/kg)
			CH.	MHz					
422.	802.11a	Back Side	48	5240	14.74	15.0	1.062	0.103	0.109
423.	802.11a	Front Side	48	5240	14.74	15.0	1.062	0.054	0.057
424.	802.11a	Left side	48	5240	14.74	15.0	1.062	0.131	0.139
425.	802.11a	Top side	48	5240	14.74	15.0	1.062	0.048	0.051

WLAN 5.3GHz –Body SAR Test

Plot No.	Mode	Test Position Body	Frequency		Output Power (dBm)	Rated Limit (dBm)	Scaling Factor	SAR1g (W/kg)	Scaled SAR1g (W/kg)
			CH.	MHz					
426.	802.11n-40	Back Side	54	5270	10.99	11.0	1.002	0.189	0.189
427.	802.11n-40	Front Side	54	5270	10.99	11.0	1.002	0.106	0.106
428.	802.11n-40	Left side	54	5270	10.99	11.0	1.002	0.147	0.147
429.	802.11n-40	Top side	54	5270	10.99	11.0	1.002	0.135	0.135

WLAN 5.6GHz –Body SAR Test

Plot No.	Mode	Test Position Body	Frequency		Output Power (dBm)	Rated Limit (dBm)	Scaling Factor	SAR1g (W/kg)	Scaled SAR1g (W/kg)
			CH.	MHz					
430.	802.11a	Back Side	100	5500	11.82	12.0	1.042	0.197	0.205
431.	802.11a	Front Side	100	5500	11.82	12.0	1.042	0.133	0.139
432.	802.11a	Left side	100	5500	11.82	12.0	1.042	0.102	0.106
433.	802.11a	Top side	100	5500	11.82	12.0	1.042	0.133	0.139

WLAN 5.8GHz –Body SAR Test									
Plot No.	Mode	Test Position Body	Frequency		Output Power (dBm)	Rated Limit (dBm)	Scaling Factor	SAR1g (W/kg)	Scaled SAR1g (W/kg)
			CH.	MHz					
434.	802.11a	Back Side	165	5825	13.79	14.0	1.050	0.215	0.226
435.	802.11a	Front Side	165	5825	13.79	14.0	1.050	0.123	0.129
436.	802.11a	Left side	165	5825	13.79	14.0	1.050	0.254	0.267
437.	802.11a	Top side	165	5825	13.79	14.0	1.050	0.132	0.139

Extremity SAR

GSM850 – Head SAR Test (Gap: 0mm)									
Plot No.	Mode	Test Position Body	Frequency		Output Power (dBm)	Rated Limit (dBm)	Scaling Factor	SAR10 g (W/kg)	Scaled SAR10 g (W/kg)
			CH.	MHz					
438.	GPRS_4TX	Back	128	824.2	29.59	30.0	1.099	0.527	0.579

GSM1900 –Head SAR Test (Gap: 0mm)									
Plot No.	Mode	Test Position Body	Frequency		Output Power (dBm)	Rated Limit (dBm)	Scaling Factor	SAR10 g (W/kg)	Scaled SAR10 g (W/kg)
			CH.	MHz					
439.	GPRS_2TX	Back	810	1909.8	29.22	30.0	1.197	2.773	3.319
440.	GPRS_2TX	Back	512	1850.2	29.67	30.0	1.079	2.691	2.903
441.	GPRS_2TX	Back	661	1880.0	29.75	30.0	1.059	2.780	2.945

Front-of the face SAR

GSM850 – Head SAR Test (Gap: 25mm)									
Plot No.	Mode	Test Position Body	Frequency		Output Power (dBm)	Rated Limit (dBm)	Scaling Factor	SAR1g (W/kg)	Scaled SAR1g (W/kg)
			CH.	MHz					
442.	GPRS_4TX	Front	128	824.2	29.59	30.0	1.099	0.006	0.007

GSM1900 –Head SAR Test (Gap: 25mm)									
Plot No.	Mode	Test Position Body	Frequency		Output Power (dBm)	Rated Limit (dBm)	Scaling Factor	SAR1g (W/kg)	Scaled SAR1g (W/kg)
			CH.	MHz					
443.	GPRS_2TX	Front	810	1909.8	29.22	29.5	1.067	0.122	0.130

Repeated SAR

GSM850 – Body SAR Test (Gap: 10mm)									
Plot No.	Mode	Test Position Body	Frequency		Output Power (dBm)	Rated Limit (dBm)	Scaling Factor	SAR1g (W/kg)	Scaled SAR1g (W/kg)
			CH.	MHz					
444.	GPRS_4TX	Back Side	128	824.2	29.59	30.0	1.099	1.011	1.111
445.	GPRS_4TX	Front Side	128	824.2	29.59	30.0	1.099	0.913	1.003

GSM1900 – Body SAR Test (Gap: 10mm)									
Plot No.	Mode	Test Position Body	Frequency		Output Power (dBm)	Rated Limit (dBm)	Scaling Factor	SAR1g (W/kg)	Scaled SAR1g (W/kg)
			CH.	MHz					
446.	GPRS_2TX	Back Side	810	1909.8	29.22	30.0	1.197	0.996	1.192
447.	GPRS_2TX	Front Side	810	1909.8	29.22	30.0	1.197	0.861	1.030
448.	GPRS_2TX	Bottom side	810	1909.8	29.22	30.0	1.197	0.789	0.944

WCDMA Band 2 – Body SAR Test (Gap: 10mm)									
Plot No.	Mode	Test Position Body	Frequency		Output Power (dBm)	Rated Limit (dBm)	Scaling Factor	SAR1g (W/kg)	Scaled SAR1g (W/kg)
			CH.	MHz					
449.	RMC 12.2k	Bottom side	9538	1907.6	22.29	22.5	1.050	0.791	0.830

WCDMA Band 4 – Body SAR Test (Gap: 10mm)									
Plot No.	Mode	Test Position Body	Frequency		Output Power (dBm)	Rated Limit (dBm)	Scaling Factor	SAR1g (W/kg)	Scaled SAR1g (W/kg)
			CH.	MHz					
450.	RMC 12.2k	Back Side	1513	1752.6	21.36	21.5	1.033	1.012	1.045
451.	RMC 12.2k	Bottom side	1513	1752.6	21.36	21.5	1.033	0.811	0.838

LTE Band 2–Body SAR Test (Gap: 10mm)									
Plot No.	Mode	Test Position Body	Frequency MHz	Output Power (dBm)	Rated Limit (dBm)	Scaling Factor	SAR1g (W/kg)	Scaled SAR1g (W/kg)	
	Modulation, Bandwidth, RB								
452.	RMC QPSK 20MHz 1RB	Bottom side	1860.0	22.77	23.0	1.054	0.903	0.952	

LTE Band 7–Body SAR Test (Gap: 10mm)									
Plot No.	Mode	Test Position Body	Frequency MHz	Output Power (dBm)	Rated Limit (dBm)	Scaling Factor	SAR1g (W/kg)	Scaled SAR1g (W/kg)	
	Modulation, Bandwidth, RB								
453.	RMC QPSK 20MHz 1RB	Back Side	2560.0	23.28	23.5	1.052	0.991	1.042	

LTE Band 25–Body SAR Test (Gap: 10mm)								
Plot No.	Mode	Test Position Body	Frequency	Output Power (dBm)	Rated Limit (dBm)	Scaling Factor	SAR1g (W/kg)	Scaled SAR1g (W/kg)
	Modulation, Bandwidth, RB		MHz					
454.	RMC QPSK 10MHz 1RB	Bottom side	1855.0	22.48	22.5	1.005	0.929	0.933

LTE Band 66:Body SAR Test (Gap: 10mm)								
Plot No.	Mode	Test Position Body	Frequency	Output Power (dBm)	Rated Limit (dBm)	Scaling Factor	SAR1g (W/kg)	Scaled SAR1g (W/kg)
	Modulation, Bandwidth, RB		MHz					
455.	RMC QPSK 5MHz 1RB	Bottom side	1712.5	25.47	25.5	1.007	0.801	0.807

Remark:

- 1) Repeated measurement is not required when the original highest measured SAR is < 0.80 W/kg; steps 2) through 4) do not apply.
- 2) When the original highest measured SAR is ≥ 0.80 W/kg, repeat that measurement once.
- 3) Perform a second repeated measurement only if the ratio of largest to smallest SAR for the original and first repeated measurements is > 1.20 or when the original or repeated measurement is ≥ 1.45 W/kg (~ 10% from the 1-g SAR limit).
- 4) Perform a third repeated measurement only if the original, first or second repeated measurement is ≥ 1.5 W/kg and the ratio of largest to smallest SAR for the original, first and second repeated measurements is > 1.20 .

9.3 Simultaneous Multi-band Transmission SAR Analysis

List of Mode for Simultaneous Multi-band Transmission

No.	Configurations	Head SAR	Body-worn SAR	Hotspot SAR
1	GSM(Voice/Data) + WLAN(2.4G)(Data)	Yes	Yes	Yes
2	WCDMA (Voice/Data)+ (2.4G)(Data)	Yes	Yes	Yes
3	LTE(Data) + (2.4G)(Data)	Yes	Yes	Yes
4	GSM(Voice/Data) + WLAN(5G)(Data)	Yes	Yes	No
5	WCDMA (Voice/Data)+ (5G)(Data)	Yes	Yes	No
6	LTE(Data) + (5G)(Data)	Yes	Yes	No
7	GSM(Voice/Data) + Bluetooth(Data)	Yes	Yes	No
8	WCDMA (Voice/Data) + Bluetooth(Data)	Yes	Yes	No
9	LTE(Data) + Bluetooth(Data)	Yes	Yes	No

Remark:

1. GSM ,WCDMA and LTE share the same antenna, and cannot transmit simultaneously.
2. WLAN and Bluetooth share the same antenna, and cannot transmit simultaneously.
3. According to the KDB 447498 D01 v06, when standalone SAR test exclusion applies to an antenna that transmits simultaneously with other antennas, the standalone SAR must be estimated according to following to determine simultaneous transmission SAR test exclusion:
 $(\text{max. power of channel, including tune-up tolerance, mW})/(\text{min. test separation distance, mm}) \cdot [\sqrt{f(\text{GHz})}/x]$ W/kg for test separation distances ≤ 50 mm;
 where $x = 7.5$ for 1-g SAR, and $x = 18.75$ for 10-g SAR.

For simultaneous transmission analysis, Bluetooth SAR is estimated per KDB 447498 D01 v06 as below:

Bluetooth:

Tune-Up Power (dBm)	Max. Power (mW)	Distance (mm)	Frequency (GHz)	X	SAR(1g) 5mm	SAR(1g) 10mm
8.0	6.31	5/10	2.402	7.5	0.261	0.131

Head SAR
WWAN and WLAN

Position	WWAN		WLAN(2.4G)	Summed SAR (W/kg)
	Band	Scaled SAR (W/kg)	Scaled SAR (W/kg)	
Right Cheek	GSM850	0.472	0.363	0.835
Right Tilted	GSM850	0.253	0.261	0.514
Left Cheek	GSM850	0.515	0.159	0.674
Left Tilted	GSM850	0.273	0.113	0.386
Right Cheek	GSM1900	0.307	0.363	0.670
Right Tilted	GSM1900	0.170	0.261	0.431
Left Cheek	GSM1900	0.215	0.159	0.374
Left Tilted	GSM1900	0.121	0.113	0.234
Right Cheek	GPRS850	0.912	0.363	1.275
Right Tilted	GPRS850	0.524	0.261	0.785
Left Cheek	GPRS850	1.073	0.159	1.232
Left Tilted	GPRS850	0.541	0.113	0.654
Right Cheek	GPRS1900	0.576	0.363	0.939
Right Tilted	GPRS1900	0.353	0.261	0.614
Left Cheek	GPRS1900	0.381	0.159	0.540
Left Tilted	GPRS1900	0.180	0.113	0.293
Right Cheek	WCDMA Band 2	0.550	0.363	0.913
Right Tilted	WCDMA Band 2	0.326	0.261	0.587
Left Cheek	WCDMA Band 2	0.352	0.159	0.511
Left Tilted	WCDMA Band 2	0.165	0.113	0.278
Right Cheek	WCDMA Band 5	0.193	0.363	0.556
Right Tilted	WCDMA Band 5	0.113	0.261	0.374
Left Cheek	WCDMA Band 5	0.198	0.159	0.357
Left Tilted	WCDMA Band 5	0.119	0.113	0.232
Right Cheek	WCDMA Band 4	0.444	0.363	0.807
Right Tilted	WCDMA Band 4	0.241	0.261	0.502
Left Cheek	WCDMA Band 4	0.262	0.159	0.421
Left Tilted	WCDMA Band 4	0.166	0.113	0.279
Right Cheek	LTE Band 2	0.067	0.363	0.430
Right Tilted	LTE Band 2	0.035	0.261	0.296
Left Cheek	LTE Band 2	0.043	0.159	0.202
Left Tilted	LTE Band 2	0.026	0.113	0.139
Right Cheek	LTE Band 4	0.092	0.363	0.455
Right Tilted	LTE Band 4	0.044	0.261	0.305
Left Cheek	LTE Band 4	0.047	0.159	0.206
Left Tilted	LTE Band 4	0.029	0.113	0.142
Right Cheek	LTE Band 5	0.003	0.363	0.366

Right Tilted	LTE Band 5	0.001	0.261	0.262
Left Cheek	LTE Band 5	0.003	0.159	0.162
Left Tilted	LTE Band 5	0.001	0.113	0.114
Right Cheek	LTE Band 7	0.392	0.363	0.755
Right Tilted	LTE Band 7	0.208	0.261	0.469
Left Cheek	LTE Band 7	0.150	0.159	0.309
Left Tilted	LTE Band 7	0.108	0.113	0.221
Right Cheek	LTE Band 12	0.012	0.363	0.375
Right Tilted	LTE Band 12	0.007	0.261	0.268
Left Cheek	LTE Band 12	0.016	0.159	0.175
Left Tilted	LTE Band 12	0.009	0.113	0.122
Right Cheek	LTE Band 13	0.005	0.363	0.368
Right Tilted	LTE Band 13	0.002	0.261	0.263
Left Cheek	LTE Band 13	0.007	0.159	0.166
Left Tilted	LTE Band 13	0.003	0.113	0.116
Right Cheek	LTE Band 17	0.011	0.363	0.374
Right Tilted	LTE Band 17	0.006	0.261	0.267
Left Cheek	LTE Band 17	0.013	0.159	0.172
Left Tilted	LTE Band 17	0.008	0.113	0.121
Right Cheek	LTE Band 25	0.039	0.363	0.402
Right Tilted	LTE Band 25	0.019	0.261	0.280
Left Cheek	LTE Band 25	0.021	0.159	0.180
Left Tilted	LTE Band 25	0.015	0.113	0.128
Right Cheek	LTE Band 26	0.005	0.363	0.368
Right Tilted	LTE Band 26	0.003	0.261	0.264
Left Cheek	LTE Band 26	0.008	0.159	0.167
Left Tilted	LTE Band 26	0.004	0.113	0.117
Right Cheek	LTE Band 30	0.200	0.363	0.563
Right Tilted	LTE Band 30	0.115	0.261	0.376
Left Cheek	LTE Band 30	0.103	0.159	0.262
Left Tilted	LTE Band 30	0.052	0.113	0.165
Right Cheek	LTE Band 40	0.096	0.363	0.459
Right Tilted	LTE Band 40	0.051	0.261	0.312
Left Cheek	LTE Band 40	0.037	0.159	0.196
Left Tilted	LTE Band 40	0.018	0.113	0.131
Right Cheek	LTE Band 66	0.057	0.363	0.420
Right Tilted	LTE Band 66	0.029	0.261	0.290
Left Cheek	LTE Band 66	0.034	0.159	0.193
Left Tilted	LTE Band 66	0.018	0.113	0.131

Position	WWAN		WLAN(5.2G)	Summed SAR (W/kg)
	Band	Scaled SAR (W/kg)	Scaled SAR (W/kg)	
Right Cheek	GSM850	0.472	0.371	0.843
Right Tilted	GSM850	0.253	0.140	0.393
Left Cheek	GSM850	0.515	0.132	0.647
Left Tilted	GSM850	0.273	0.069	0.342
Right Cheek	GSM1900	0.307	0.371	0.678
Right Tilted	GSM1900	0.170	0.140	0.310
Left Cheek	GSM1900	0.215	0.132	0.347
Left Tilted	GSM1900	0.121	0.069	0.190
Right Cheek	GPRS850	0.912	0.371	1.283
Right Tilted	GPRS850	0.524	0.140	0.664
Left Cheek	GPRS850	1.073	0.132	1.205
Left Tilted	GPRS850	0.541	0.069	0.610
Right Cheek	GPRS1900	0.576	0.371	0.947
Right Tilted	GPRS1900	0.353	0.140	0.493
Left Cheek	GPRS1900	0.381	0.132	0.513
Left Tilted	GPRS1900	0.180	0.069	0.249
Right Cheek	WCDMA Band 2	0.550	0.371	0.921
Right Tilted	WCDMA Band 2	0.326	0.140	0.466
Left Cheek	WCDMA Band 2	0.352	0.132	0.484
Left Tilted	WCDMA Band 2	0.165	0.069	0.234
Right Cheek	WCDMA Band 5	0.193	0.371	0.564
Right Tilted	WCDMA Band 5	0.113	0.140	0.253
Left Cheek	WCDMA Band 5	0.198	0.132	0.330
Left Tilted	WCDMA Band 5	0.119	0.069	0.188
Right Cheek	WCDMA Band 4	0.444	0.371	0.815
Right Tilted	WCDMA Band 4	0.241	0.140	0.381
Left Cheek	WCDMA Band 4	0.262	0.132	0.394
Left Tilted	WCDMA Band 4	0.166	0.069	0.235
Right Cheek	LTE Band 2	0.067	0.371	0.438
Right Tilted	LTE Band 2	0.035	0.140	0.175
Left Cheek	LTE Band 2	0.043	0.132	0.175
Left Tilted	LTE Band 2	0.026	0.069	0.095
Right Cheek	LTE Band 4	0.092	0.371	0.463
Right Tilted	LTE Band 4	0.044	0.140	0.184
Left Cheek	LTE Band 4	0.047	0.132	0.179
Left Tilted	LTE Band 4	0.029	0.069	0.098
Right Cheek	LTE Band 5	0.003	0.371	0.374
Right Tilted	LTE Band 5	0.001	0.140	0.141
Left Cheek	LTE Band 5	0.003	0.132	0.135

Left Tilted	LTE Band 5	0.001	0.069	0.070
Right Cheek	LTE Band 7	0.392	0.371	0.763
Right Tilted	LTE Band 7	0.208	0.140	0.348
Left Cheek	LTE Band 7	0.150	0.132	0.282
Left Tilted	LTE Band 7	0.108	0.069	0.177
Right Cheek	LTE Band 12	0.012	0.371	0.383
Right Tilted	LTE Band 12	0.007	0.140	0.147
Left Cheek	LTE Band 12	0.016	0.132	0.148
Left Tilted	LTE Band 12	0.009	0.069	0.078
Right Cheek	LTE Band 13	0.005	0.371	0.376
Right Tilted	LTE Band 13	0.002	0.140	0.142
Left Cheek	LTE Band 13	0.007	0.132	0.139
Left Tilted	LTE Band 13	0.003	0.069	0.072
Right Cheek	LTE Band 17	0.011	0.371	0.382
Right Tilted	LTE Band 17	0.006	0.140	0.146
Left Cheek	LTE Band 17	0.013	0.132	0.145
Left Tilted	LTE Band 17	0.008	0.069	0.077
Right Cheek	LTE Band 25	0.039	0.371	0.410
Right Tilted	LTE Band 25	0.019	0.140	0.159
Left Cheek	LTE Band 25	0.021	0.132	0.153
Left Tilted	LTE Band 25	0.015	0.069	0.084
Right Cheek	LTE Band 26	0.005	0.371	0.376
Right Tilted	LTE Band 26	0.003	0.140	0.143
Left Cheek	LTE Band 26	0.008	0.132	0.140
Left Tilted	LTE Band 26	0.004	0.069	0.073
Right Cheek	LTE Band 30	0.200	0.371	0.571
Right Tilted	LTE Band 30	0.115	0.140	0.255
Left Cheek	LTE Band 30	0.103	0.132	0.235
Left Tilted	LTE Band 30	0.052	0.069	0.121
Right Cheek	LTE Band 40	0.096	0.371	0.467
Right Tilted	LTE Band 40	0.051	0.140	0.191
Left Cheek	LTE Band 40	0.037	0.132	0.169
Left Tilted	LTE Band 40	0.018	0.069	0.087
Right Cheek	LTE Band 66	0.057	0.371	0.428
Right Tilted	LTE Band 66	0.029	0.140	0.169
Left Cheek	LTE Band 66	0.034	0.132	0.166
Left Tilted	LTE Band 66	0.018	0.069	0.087

Position	WWAN		WLAN(5.3G)	Summed SAR (W/kg)
	Band	Scaled SAR (W/kg)	Scaled SAR (W/kg)	
Right Cheek	GSM850	0.472	0.058	0.530
Right Tilted	GSM850	0.253	0.031	0.284
Left Cheek	GSM850	0.515	0.138	0.653
Left Tilted	GSM850	0.273	0.072	0.345
Right Cheek	GSM1900	0.307	0.058	0.365
Right Tilted	GSM1900	0.170	0.031	0.201
Left Cheek	GSM1900	0.215	0.138	0.353
Left Tilted	GSM1900	0.121	0.072	0.193
Right Cheek	GPRS850	0.912	0.058	0.970
Right Tilted	GPRS850	0.524	0.031	0.555
Left Cheek	GPRS850	1.073	0.138	1.211
Left Tilted	GPRS850	0.541	0.072	0.613
Right Cheek	GPRS1900	0.576	0.058	0.634
Right Tilted	GPRS1900	0.353	0.031	0.384
Left Cheek	GPRS1900	0.381	0.138	0.519
Left Tilted	GPRS1900	0.180	0.072	0.252
Right Cheek	WCDMA Band 2	0.550	0.058	0.608
Right Tilted	WCDMA Band 2	0.326	0.031	0.357
Left Cheek	WCDMA Band 2	0.352	0.138	0.490
Left Tilted	WCDMA Band 2	0.165	0.072	0.237
Right Cheek	WCDMA Band 5	0.193	0.058	0.251
Right Tilted	WCDMA Band 5	0.113	0.031	0.144
Left Cheek	WCDMA Band 5	0.198	0.138	0.336
Left Tilted	WCDMA Band 5	0.119	0.072	0.191
Right Cheek	WCDMA Band 4	0.444	0.058	0.502
Right Tilted	WCDMA Band 4	0.241	0.031	0.272
Left Cheek	WCDMA Band 4	0.262	0.138	0.400
Left Tilted	WCDMA Band 4	0.166	0.072	0.238
Right Cheek	LTE Band 2	0.067	0.058	0.125
Right Tilted	LTE Band 2	0.035	0.031	0.066
Left Cheek	LTE Band 2	0.043	0.138	0.181
Left Tilted	LTE Band 2	0.026	0.072	0.098
Right Cheek	LTE Band 4	0.092	0.058	0.150
Right Tilted	LTE Band 4	0.044	0.031	0.075
Left Cheek	LTE Band 4	0.047	0.138	0.185
Left Tilted	LTE Band 4	0.029	0.072	0.101
Right Cheek	LTE Band 5	0.003	0.058	0.061
Right Tilted	LTE Band 5	0.001	0.031	0.032
Left Cheek	LTE Band 5	0.003	0.138	0.141

Left Tilted	LTE Band 5	0.001	0.072	0.073
Right Cheek	LTE Band 7	0.392	0.058	0.450
Right Tilted	LTE Band 7	0.208	0.031	0.239
Left Cheek	LTE Band 7	0.150	0.138	0.288
Left Tilted	LTE Band 7	0.108	0.072	0.180
Right Cheek	LTE Band 12	0.012	0.058	0.070
Right Tilted	LTE Band 12	0.007	0.031	0.038
Left Cheek	LTE Band 12	0.016	0.138	0.154
Left Tilted	LTE Band 12	0.009	0.072	0.081
Right Cheek	LTE Band 13	0.005	0.058	0.063
Right Tilted	LTE Band 13	0.002	0.031	0.033
Left Cheek	LTE Band 13	0.007	0.138	0.145
Left Tilted	LTE Band 13	0.003	0.072	0.075
Right Cheek	LTE Band 17	0.011	0.058	0.069
Right Tilted	LTE Band 17	0.006	0.031	0.037
Left Cheek	LTE Band 17	0.013	0.138	0.151
Left Tilted	LTE Band 17	0.008	0.072	0.080
Right Cheek	LTE Band 25	0.039	0.058	0.097
Right Tilted	LTE Band 25	0.019	0.031	0.050
Left Cheek	LTE Band 25	0.021	0.138	0.159
Left Tilted	LTE Band 25	0.015	0.072	0.087
Right Cheek	LTE Band 26	0.005	0.058	0.063
Right Tilted	LTE Band 26	0.003	0.031	0.034
Left Cheek	LTE Band 26	0.008	0.138	0.146
Left Tilted	LTE Band 26	0.004	0.072	0.076
Right Cheek	LTE Band 30	0.200	0.058	0.258
Right Tilted	LTE Band 30	0.115	0.031	0.146
Left Cheek	LTE Band 30	0.103	0.138	0.241
Left Tilted	LTE Band 30	0.052	0.072	0.124
Right Cheek	LTE Band 40	0.096	0.058	0.154
Right Tilted	LTE Band 40	0.051	0.031	0.082
Left Cheek	LTE Band 40	0.037	0.138	0.175
Left Tilted	LTE Band 40	0.018	0.072	0.090
Right Cheek	LTE Band 66	0.057	0.058	0.115
Right Tilted	LTE Band 66	0.029	0.031	0.060
Left Cheek	LTE Band 66	0.034	0.138	0.172
Left Tilted	LTE Band 66	0.018	0.072	0.090

Position	WWAN		WLAN(5.6G)	Summed SAR (W/kg)
	Band	Scaled SAR (W/kg)	Scaled SAR (W/kg)	
Right Cheek	GSM850	0.472	0.113	0.585
Right Tilted	GSM850	0.253	0.057	0.310
Left Cheek	GSM850	0.515	0.319	0.834
Left Tilted	GSM850	0.273	0.170	0.443
Right Cheek	GSM1900	0.307	0.113	0.420
Right Tilted	GSM1900	0.170	0.057	0.227
Left Cheek	GSM1900	0.215	0.319	0.534
Left Tilted	GSM1900	0.121	0.170	0.291
Right Cheek	GPRS850	0.912	0.113	1.025
Right Tilted	GPRS850	0.524	0.057	0.581
Left Cheek	GPRS850	1.073	0.319	1.392
Left Tilted	GPRS850	0.541	0.170	0.711
Right Cheek	GPRS1900	0.576	0.113	0.689
Right Tilted	GPRS1900	0.353	0.057	0.410
Left Cheek	GPRS1900	0.381	0.319	0.700
Left Tilted	GPRS1900	0.180	0.170	0.350
Right Cheek	WCDMA Band 2	0.550	0.113	0.663
Right Tilted	WCDMA Band 2	0.326	0.057	0.383
Left Cheek	WCDMA Band 2	0.352	0.319	0.671
Left Tilted	WCDMA Band 2	0.165	0.170	0.335
Right Cheek	WCDMA Band 5	0.193	0.113	0.306
Right Tilted	WCDMA Band 5	0.113	0.057	0.170
Left Cheek	WCDMA Band 5	0.198	0.319	0.517
Left Tilted	WCDMA Band 5	0.119	0.170	0.289
Right Cheek	WCDMA Band 4	0.444	0.113	0.557
Right Tilted	WCDMA Band 4	0.241	0.057	0.298
Left Cheek	WCDMA Band 4	0.262	0.319	0.581
Left Tilted	WCDMA Band 4	0.166	0.170	0.336
Right Cheek	LTE Band 2	0.067	0.113	0.180
Right Tilted	LTE Band 2	0.035	0.057	0.092
Left Cheek	LTE Band 2	0.043	0.319	0.362
Left Tilted	LTE Band 2	0.026	0.170	0.196
Right Cheek	LTE Band 4	0.092	0.113	0.205
Right Tilted	LTE Band 4	0.044	0.057	0.101
Left Cheek	LTE Band 4	0.047	0.319	0.366
Left Tilted	LTE Band 4	0.029	0.170	0.199
Right Cheek	LTE Band 5	0.003	0.113	0.116
Right Tilted	LTE Band 5	0.001	0.057	0.058
Left Cheek	LTE Band 5	0.003	0.319	0.322

Left Tilted	LTE Band 5	0.001	0.170	0.171
Right Cheek	LTE Band 7	0.392	0.113	0.505
Right Tilted	LTE Band 7	0.208	0.057	0.265
Left Cheek	LTE Band 7	0.150	0.319	0.469
Left Tilted	LTE Band 7	0.108	0.170	0.278
Right Cheek	LTE Band 12	0.012	0.113	0.125
Right Tilted	LTE Band 12	0.007	0.057	0.064
Left Cheek	LTE Band 12	0.016	0.319	0.335
Left Tilted	LTE Band 12	0.009	0.170	0.179
Right Cheek	LTE Band 13	0.005	0.113	0.118
Right Tilted	LTE Band 13	0.002	0.057	0.059
Left Cheek	LTE Band 13	0.007	0.319	0.326
Left Tilted	LTE Band 13	0.003	0.170	0.173
Right Cheek	LTE Band 17	0.011	0.113	0.124
Right Tilted	LTE Band 17	0.006	0.057	0.063
Left Cheek	LTE Band 17	0.013	0.319	0.332
Left Tilted	LTE Band 17	0.008	0.170	0.178
Right Cheek	LTE Band 25	0.039	0.113	0.152
Right Tilted	LTE Band 25	0.019	0.057	0.076
Left Cheek	LTE Band 25	0.021	0.319	0.340
Left Tilted	LTE Band 25	0.015	0.170	0.185
Right Cheek	LTE Band 26	0.005	0.113	0.118
Right Tilted	LTE Band 26	0.003	0.057	0.060
Left Cheek	LTE Band 26	0.008	0.319	0.327
Left Tilted	LTE Band 26	0.004	0.170	0.174
Right Cheek	LTE Band 30	0.200	0.113	0.313
Right Tilted	LTE Band 30	0.115	0.057	0.172
Left Cheek	LTE Band 30	0.103	0.319	0.422
Left Tilted	LTE Band 30	0.052	0.170	0.222
Right Cheek	LTE Band 40	0.096	0.113	0.209
Right Tilted	LTE Band 40	0.051	0.057	0.108
Left Cheek	LTE Band 40	0.037	0.319	0.356
Left Tilted	LTE Band 40	0.018	0.170	0.188
Right Cheek	LTE Band 66	0.057	0.113	0.170
Right Tilted	LTE Band 66	0.029	0.057	0.086
Left Cheek	LTE Band 66	0.034	0.319	0.353
Left Tilted	LTE Band 66	0.018	0.170	0.188

Position	WWAN		WLAN(5.8G)	Summed SAR (W/kg)
	Band	Scaled SAR (W/kg)	Scaled SAR (W/kg)	
Right Cheek	GSM850	0.472	0.110	0.582
Right Tilted	GSM850	0.253	0.055	0.308
Left Cheek	GSM850	0.515	0.068	0.583
Left Tilted	GSM850	0.273	0.035	0.308
Right Cheek	GSM1900	0.307	0.110	0.417
Right Tilted	GSM1900	0.170	0.055	0.225
Left Cheek	GSM1900	0.215	0.068	0.283
Left Tilted	GSM1900	0.121	0.035	0.156
Right Cheek	GPRS850	0.912	0.110	1.022
Right Tilted	GPRS850	0.524	0.055	0.579
Left Cheek	GPRS850	1.073	0.068	1.141
Left Tilted	GPRS850	0.541	0.035	0.576
Right Cheek	GPRS1900	0.576	0.110	0.686
Right Tilted	GPRS1900	0.353	0.055	0.408
Left Cheek	GPRS1900	0.381	0.068	0.449
Left Tilted	GPRS1900	0.180	0.035	0.215
Right Cheek	WCDMA Band 2	0.550	0.110	0.660
Right Tilted	WCDMA Band 2	0.326	0.055	0.381
Left Cheek	WCDMA Band 2	0.352	0.068	0.420
Left Tilted	WCDMA Band 2	0.165	0.035	0.200
Right Cheek	WCDMA Band 5	0.193	0.110	0.303
Right Tilted	WCDMA Band 5	0.113	0.055	0.168
Left Cheek	WCDMA Band 5	0.198	0.068	0.266
Left Tilted	WCDMA Band 5	0.119	0.035	0.154
Right Cheek	WCDMA Band 4	0.444	0.110	0.554
Right Tilted	WCDMA Band 4	0.241	0.055	0.296
Left Cheek	WCDMA Band 4	0.262	0.068	0.330
Left Tilted	WCDMA Band 4	0.166	0.035	0.201
Right Cheek	LTE Band 2	0.067	0.110	0.177
Right Tilted	LTE Band 2	0.035	0.055	0.090
Left Cheek	LTE Band 2	0.043	0.068	0.111
Left Tilted	LTE Band 2	0.026	0.035	0.061
Right Cheek	LTE Band 4	0.092	0.110	0.202
Right Tilted	LTE Band 4	0.044	0.055	0.099
Left Cheek	LTE Band 4	0.047	0.068	0.115
Left Tilted	LTE Band 4	0.029	0.035	0.064
Right Cheek	LTE Band 5	0.003	0.110	0.113
Right Tilted	LTE Band 5	0.001	0.055	0.056
Left Cheek	LTE Band 5	0.003	0.068	0.071

Left Tilted	LTE Band 5	0.001	0.035	0.036
Right Cheek	LTE Band 7	0.392	0.110	0.502
Right Tilted	LTE Band 7	0.208	0.055	0.263
Left Cheek	LTE Band 7	0.150	0.068	0.218
Left Tilted	LTE Band 7	0.108	0.035	0.143
Right Cheek	LTE Band 12	0.012	0.110	0.122
Right Tilted	LTE Band 12	0.007	0.055	0.062
Left Cheek	LTE Band 12	0.016	0.068	0.084
Left Tilted	LTE Band 12	0.009	0.035	0.044
Right Cheek	LTE Band 13	0.005	0.110	0.115
Right Tilted	LTE Band 13	0.002	0.055	0.057
Left Cheek	LTE Band 13	0.007	0.068	0.075
Left Tilted	LTE Band 13	0.003	0.035	0.038
Right Cheek	LTE Band 17	0.011	0.110	0.121
Right Tilted	LTE Band 17	0.006	0.055	0.061
Left Cheek	LTE Band 17	0.013	0.068	0.081
Left Tilted	LTE Band 17	0.008	0.035	0.043
Right Cheek	LTE Band 25	0.039	0.110	0.149
Right Tilted	LTE Band 25	0.019	0.055	0.074
Left Cheek	LTE Band 25	0.021	0.068	0.089
Left Tilted	LTE Band 25	0.015	0.035	0.050
Right Cheek	LTE Band 26	0.005	0.110	0.115
Right Tilted	LTE Band 26	0.003	0.055	0.058
Left Cheek	LTE Band 26	0.008	0.068	0.076
Left Tilted	LTE Band 26	0.004	0.035	0.039
Right Cheek	LTE Band 30	0.200	0.110	0.310
Right Tilted	LTE Band 30	0.115	0.055	0.170
Left Cheek	LTE Band 30	0.103	0.068	0.171
Left Tilted	LTE Band 30	0.052	0.035	0.087
Right Cheek	LTE Band 40	0.096	0.110	0.206
Right Tilted	LTE Band 40	0.051	0.055	0.106
Left Cheek	LTE Band 40	0.037	0.068	0.105
Left Tilted	LTE Band 40	0.018	0.035	0.053
Right Cheek	LTE Band 66	0.057	0.110	0.167
Right Tilted	LTE Band 66	0.029	0.055	0.084
Left Cheek	LTE Band 66	0.034	0.068	0.102
Left Tilted	LTE Band 66	0.018	0.035	0.053

WWAN and Bluetooth

Position	WWAN		Bluetooth	Summed SAR (W/kg)
	Band	Scaled SAR (W/kg)	Scaled SAR (W/kg)	
Right Cheek	GSM850	0.472	0.261	0.733
Right Tilted	GSM850	0.253	0.261	0.514
Left Cheek	GSM850	0.515	0.261	0.776
Left Tilted	GSM850	0.273	0.261	0.534
Right Cheek	GSM1900	0.307	0.261	0.568
Right Tilted	GSM1900	0.170	0.261	0.431
Left Cheek	GSM1900	0.215	0.261	0.476
Left Tilted	GSM1900	0.121	0.261	0.382
Right Cheek	GPRS850	0.912	0.261	1.173
Right Tilted	GPRS850	0.524	0.261	0.785
Left Cheek	GPRS850	1.073	0.261	1.334
Left Tilted	GPRS850	0.541	0.261	0.802
Right Cheek	GPRS1900	0.576	0.261	0.837
Right Tilted	GPRS1900	0.353	0.261	0.614
Left Cheek	GPRS1900	0.381	0.261	0.642
Left Tilted	GPRS1900	0.180	0.261	0.441
Right Cheek	WCDMA Band 2	0.550	0.261	0.811
Right Tilted	WCDMA Band 2	0.326	0.261	0.587
Left Cheek	WCDMA Band 2	0.352	0.261	0.613
Left Tilted	WCDMA Band 2	0.165	0.261	0.426
Right Cheek	WCDMA Band 5	0.193	0.261	0.454
Right Tilted	WCDMA Band 5	0.113	0.261	0.374
Left Cheek	WCDMA Band 5	0.198	0.261	0.459
Left Tilted	WCDMA Band 5	0.119	0.261	0.380
Right Cheek	WCDMA Band 4	0.444	0.261	0.705
Right Tilted	WCDMA Band 4	0.241	0.261	0.502
Left Cheek	WCDMA Band 4	0.262	0.261	0.523
Left Tilted	WCDMA Band 4	0.166	0.261	0.427
Right Cheek	LTE Band 2	0.067	0.261	0.328
Right Tilted	LTE Band 2	0.035	0.261	0.296
Left Cheek	LTE Band 2	0.043	0.261	0.304
Left Tilted	LTE Band 2	0.026	0.261	0.287
Right Cheek	LTE Band 4	0.092	0.261	0.353
Right Tilted	LTE Band 4	0.044	0.261	0.305
Left Cheek	LTE Band 4	0.047	0.261	0.308
Left Tilted	LTE Band 4	0.029	0.261	0.290
Right Cheek	LTE Band 5	0.003	0.261	0.264
Right Tilted	LTE Band 5	0.001	0.261	0.262

Left Cheek	LTE Band 5	0.003	0.261	0.264
Left Tilted	LTE Band 5	0.001	0.261	0.262
Right Cheek	LTE Band 7	0.392	0.261	0.653
Right Tilted	LTE Band 7	0.208	0.261	0.469
Left Cheek	LTE Band 7	0.150	0.261	0.411
Left Tilted	LTE Band 7	0.108	0.261	0.369
Right Cheek	LTE Band 12	0.012	0.261	0.273
Right Tilted	LTE Band 12	0.007	0.261	0.268
Left Cheek	LTE Band 12	0.016	0.261	0.277
Left Tilted	LTE Band 12	0.009	0.261	0.270
Right Cheek	LTE Band 13	0.005	0.261	0.266
Right Tilted	LTE Band 13	0.002	0.261	0.263
Left Cheek	LTE Band 13	0.007	0.261	0.268
Left Tilted	LTE Band 13	0.003	0.261	0.264
Right Cheek	LTE Band 17	0.011	0.261	0.272
Right Tilted	LTE Band 17	0.006	0.261	0.267
Left Cheek	LTE Band 17	0.013	0.261	0.274
Left Tilted	LTE Band 17	0.008	0.261	0.269
Right Cheek	LTE Band 25	0.039	0.261	0.300
Right Tilted	LTE Band 25	0.019	0.261	0.280
Left Cheek	LTE Band 25	0.021	0.261	0.282
Left Tilted	LTE Band 25	0.015	0.261	0.276
Right Cheek	LTE Band 26	0.005	0.261	0.266
Right Tilted	LTE Band 26	0.003	0.261	0.264
Left Cheek	LTE Band 26	0.008	0.261	0.269
Left Tilted	LTE Band 26	0.004	0.261	0.265
Right Cheek	LTE Band 30	0.200	0.261	0.461
Right Tilted	LTE Band 30	0.115	0.261	0.376
Left Cheek	LTE Band 30	0.103	0.261	0.364
Left Tilted	LTE Band 30	0.052	0.261	0.313
Right Cheek	LTE Band 40	0.096	0.261	0.357
Right Tilted	LTE Band 40	0.051	0.261	0.312
Left Cheek	LTE Band 40	0.037	0.261	0.298
Left Tilted	LTE Band 40	0.018	0.261	0.279
Right Cheek	LTE Band 66	0.057	0.261	0.318
Right Tilted	LTE Band 66	0.029	0.261	0.290
Left Cheek	LTE Band 66	0.034	0.261	0.295
Left Tilted	LTE Band 66	0.018	0.261	0.279

Body-worn SAR
WWAN and WLAN

Position	WWAN		WLAN(2.4G)	Summed SAR (W/kg)
	Band	Scaled SAR (W/kg)	Scaled SAR (W/kg)	
Back	GSM850	0.552	0.171	0.723
Front	GSM850	0.456	0.098	0.554
Back	GSM1900	0.602	0.171	0.773
Front	GSM1900	0.545	0.098	0.643
Back	WCDMA Band 2	0.925	0.171	1.096
Front	WCDMA Band 2	0.782	0.098	0.880
Back	WCDMA Band 5	0.274	0.171	0.445
Front	WCDMA Band 5	0.214	0.098	0.312
Back	WCDMA Band 4	1.113	0.171	1.284
Front	WCDMA Band 4	0.743	0.098	0.841
Back	LTE Band 2	0.495	0.171	0.666
Front	LTE Band 2	0.164	0.098	0.262
Back	LTE Band 4	0.400	0.171	0.571
Front	LTE Band 4	0.138	0.098	0.236
Back	LTE Band 5	0.032	0.171	0.203
Front	LTE Band 5	0.004	0.098	0.102
Back	LTE Band 7	1.060	0.171	1.231
Front	LTE Band 7	0.697	0.098	0.795
Back	LTE Band 12	0.042	0.171	0.213
Front	LTE Band 12	0.022	0.098	0.120
Back	LTE Band 13	0.035	0.171	0.206
Front	LTE Band 13	0.007	0.098	0.105
Back	LTE Band 17	0.036	0.171	0.207
Front	LTE Band 17	0.021	0.098	0.119
Back	LTE Band 25	0.582	0.171	0.753
Front	LTE Band 25	0.414	0.098	0.512
Back	LTE Band 26	0.057	0.171	0.228
Front	LTE Band 26	0.013	0.098	0.111
Back	LTE Band 30	0.357	0.171	0.528
Front	LTE Band 30	0.331	0.098	0.429
Back	LTE Band 40	0.126	0.171	0.297
Front	LTE Band 40	0.092	0.098	0.190
Back	LTE Band 66	0.586	0.171	0.757
Front	LTE Band 66	0.401	0.098	0.499

Position	WWAN		WLAN(5.2G)	Summed SAR (W/kg)
	Band	Scaled SAR (W/kg)	Scaled SAR (W/kg)	
Back	GSM850	0.552	0.109	0.661
Front	GSM850	0.456	0.057	0.513
Back	GSM1900	0.602	0.109	0.711
Front	GSM1900	0.545	0.057	0.602
Back	WCDMA Band 2	0.925	0.109	1.034
Front	WCDMA Band 2	0.782	0.057	0.839
Back	WCDMA Band 5	0.274	0.109	0.383
Front	WCDMA Band 5	0.214	0.057	0.271
Back	WCDMA Band 4	1.113	0.109	1.222
Front	WCDMA Band 4	0.743	0.057	0.800
Back	LTE Band 2	0.495	0.109	0.604
Front	LTE Band 2	0.164	0.057	0.221
Back	LTE Band 4	0.400	0.109	0.509
Front	LTE Band 4	0.138	0.057	0.195
Back	LTE Band 5	0.032	0.109	0.141
Front	LTE Band 5	0.004	0.057	0.061
Back	LTE Band 7	1.060	0.109	1.169
Front	LTE Band 7	0.697	0.057	0.754
Back	LTE Band 12	0.042	0.109	0.151
Front	LTE Band 12	0.022	0.057	0.079
Back	LTE Band 13	0.035	0.109	0.144
Front	LTE Band 13	0.007	0.057	0.064
Back	LTE Band 17	0.036	0.109	0.145
Front	LTE Band 17	0.021	0.057	0.078
Back	LTE Band 25	0.582	0.109	0.691
Front	LTE Band 25	0.414	0.057	0.471
Back	LTE Band 26	0.057	0.109	0.166
Front	LTE Band 26	0.013	0.057	0.070
Back	LTE Band 30	0.357	0.109	0.466
Front	LTE Band 30	0.331	0.057	0.388
Back	LTE Band 40	0.126	0.109	0.235
Front	LTE Band 40	0.092	0.057	0.149
Back	LTE Band 66	0.586	0.109	0.695
Front	LTE Band 66	0.401	0.057	0.458

Position	WWAN		WLAN(5.3G)	Summed SAR (W/kg)
	Band	Scaled SAR (W/kg)	Scaled SAR (W/kg)	
Back	GSM850	0.552	0.189	0.741
Front	GSM850	0.456	0.106	0.562
Back	GSM1900	0.602	0.189	0.791
Front	GSM1900	0.545	0.106	0.651
Back	WCDMA Band 2	0.925	0.189	1.114
Front	WCDMA Band 2	0.782	0.106	0.888
Back	WCDMA Band 5	0.274	0.189	0.463
Front	WCDMA Band 5	0.214	0.106	0.320
Back	WCDMA Band 4	1.113	0.189	1.302
Front	WCDMA Band 4	0.743	0.106	0.849
Back	LTE Band 2	0.495	0.189	0.684
Front	LTE Band 2	0.164	0.106	0.270
Back	LTE Band 4	0.400	0.189	0.589
Front	LTE Band 4	0.138	0.106	0.244
Back	LTE Band 5	0.032	0.189	0.221
Front	LTE Band 5	0.004	0.106	0.110
Back	LTE Band 7	1.060	0.189	1.249
Front	LTE Band 7	0.697	0.106	0.803
Back	LTE Band 12	0.042	0.189	0.231
Front	LTE Band 12	0.022	0.106	0.128
Back	LTE Band 13	0.035	0.189	0.224
Front	LTE Band 13	0.007	0.106	0.113
Back	LTE Band 17	0.036	0.189	0.225
Front	LTE Band 17	0.021	0.106	0.127
Back	LTE Band 25	0.582	0.189	0.771
Front	LTE Band 25	0.414	0.106	0.520
Back	LTE Band 26	0.057	0.189	0.246
Front	LTE Band 26	0.013	0.106	0.119
Back	LTE Band 30	0.357	0.189	0.546
Front	LTE Band 30	0.331	0.106	0.437
Back	LTE Band 40	0.126	0.189	0.315
Front	LTE Band 40	0.092	0.106	0.198
Back	LTE Band 66	0.586	0.189	0.775
Front	LTE Band 66	0.401	0.106	0.507

Position	WWAN		WLAN(5.6G)	Summed SAR (W/kg)
	Band	Scaled SAR (W/kg)	Scaled SAR (W/kg)	
Back	GSM850	0.552	0.373	0.925
Front	GSM850	0.456	0.139	0.595
Back	GSM1900	0.602	0.373	0.975
Front	GSM1900	0.545	0.139	0.684
Back	WCDMA Band 2	0.925	0.373	1.298
Front	WCDMA Band 2	0.782	0.139	0.921
Back	WCDMA Band 5	0.274	0.373	0.647
Front	WCDMA Band 5	0.214	0.139	0.353
Back	WCDMA Band 4	1.113	0.373	1.486
Front	WCDMA Band 4	0.743	0.139	0.882
Back	LTE Band 2	0.495	0.373	0.868
Front	LTE Band 2	0.164	0.139	0.303
Back	LTE Band 4	0.400	0.373	0.773
Front	LTE Band 4	0.138	0.139	0.277
Back	LTE Band 5	0.032	0.373	0.405
Front	LTE Band 5	0.004	0.139	0.143
Back	LTE Band 7	1.060	0.373	1.433
Front	LTE Band 7	0.697	0.139	0.836
Back	LTE Band 12	0.042	0.373	0.415
Front	LTE Band 12	0.022	0.139	0.161
Back	LTE Band 13	0.035	0.373	0.408
Front	LTE Band 13	0.007	0.139	0.146
Back	LTE Band 17	0.036	0.373	0.409
Front	LTE Band 17	0.021	0.139	0.160
Back	LTE Band 25	0.582	0.373	0.955
Front	LTE Band 25	0.414	0.139	0.553
Back	LTE Band 26	0.057	0.373	0.430
Front	LTE Band 26	0.013	0.139	0.152
Back	LTE Band 30	0.357	0.373	0.730
Front	LTE Band 30	0.331	0.139	0.470
Back	LTE Band 40	0.126	0.373	0.499
Front	LTE Band 40	0.092	0.139	0.231
Back	LTE Band 66	0.586	0.373	0.959
Front	LTE Band 66	0.401	0.139	0.540

Position	WWAN		WLAN(5.8G)	Summed SAR (W/kg)
	Band	Scaled SAR (W/kg)	Scaled SAR (W/kg)	
Back	GSM850	0.552	0.226	0.778
Front	GSM850	0.456	0.129	0.585
Back	GSM1900	0.602	0.226	0.828
Front	GSM1900	0.545	0.129	0.674
Back	WCDMA Band 2	0.925	0.226	1.151
Front	WCDMA Band 2	0.782	0.129	0.911
Back	WCDMA Band 5	0.274	0.226	0.500
Front	WCDMA Band 5	0.214	0.129	0.343
Back	WCDMA Band 4	1.113	0.226	1.339
Front	WCDMA Band 4	0.743	0.129	0.872
Back	LTE Band 2	0.495	0.226	0.721
Front	LTE Band 2	0.164	0.129	0.293
Back	LTE Band 4	0.400	0.226	0.626
Front	LTE Band 4	0.138	0.129	0.267
Back	LTE Band 5	0.032	0.226	0.258
Front	LTE Band 5	0.004	0.129	0.133
Back	LTE Band 7	1.060	0.226	1.286
Front	LTE Band 7	0.697	0.129	0.826
Back	LTE Band 12	0.042	0.226	0.268
Front	LTE Band 12	0.022	0.129	0.151
Back	LTE Band 13	0.035	0.226	0.261
Front	LTE Band 13	0.007	0.129	0.136
Back	LTE Band 17	0.036	0.226	0.262
Front	LTE Band 17	0.021	0.129	0.150
Back	LTE Band 25	0.582	0.226	0.808
Front	LTE Band 25	0.414	0.129	0.543
Back	LTE Band 26	0.057	0.226	0.283
Front	LTE Band 26	0.013	0.129	0.142
Back	LTE Band 30	0.357	0.226	0.583
Front	LTE Band 30	0.331	0.129	0.460
Back	LTE Band 40	0.126	0.226	0.352
Front	LTE Band 40	0.092	0.129	0.221
Back	LTE Band 66	0.586	0.226	0.812
Front	LTE Band 66	0.401	0.129	0.530

WWAN and Bluetooth

Position	WWAN		Bluetooth	Summed SAR (W/kg)
	Band	Scaled SAR (W/kg)	Scaled SAR (W/kg)	
Back	GSM850	0.552	0.131	0.683
Front	GSM850	0.456	0.131	0.587
Back	GSM1900	0.602	0.131	0.733
Front	GSM1900	0.545	0.131	0.676
Back	WCDMA Band 2	0.925	0.131	1.056
Front	WCDMA Band 2	0.782	0.131	0.913
Back	WCDMA Band 5	0.274	0.131	0.405
Front	WCDMA Band 5	0.214	0.131	0.345
Back	WCDMA Band 4	1.113	0.131	1.244
Front	WCDMA Band 4	0.743	0.131	0.874
Back	LTE Band 2	0.495	0.131	0.626
Front	LTE Band 2	0.164	0.131	0.295
Back	LTE Band 4	0.400	0.131	0.531
Front	LTE Band 4	0.138	0.131	0.269
Back	LTE Band 5	0.032	0.131	0.163
Front	LTE Band 5	0.004	0.131	0.135
Back	LTE Band 7	1.060	0.131	1.191
Front	LTE Band 7	0.697	0.131	0.828
Back	LTE Band 12	0.042	0.131	0.173
Front	LTE Band 12	0.022	0.131	0.153
Back	LTE Band 13	0.035	0.131	0.166
Front	LTE Band 13	0.007	0.131	0.138
Back	LTE Band 17	0.036	0.131	0.167
Front	LTE Band 17	0.021	0.131	0.152
Back	LTE Band 25	0.582	0.131	0.713
Front	LTE Band 25	0.414	0.131	0.545
Back	LTE Band 26	0.057	0.131	0.188
Front	LTE Band 26	0.013	0.131	0.144
Back	LTE Band 30	0.357	0.131	0.488
Front	LTE Band 30	0.331	0.131	0.462
Back	LTE Band 40	0.126	0.131	0.257
Front	LTE Band 40	0.092	0.131	0.223
Back	LTE Band 66	0.586	0.131	0.717
Front	LTE Band 66	0.401	0.131	0.532

Hotspot SAR
WWAN and WLAN

Position	WWAN		WLAN(2.4G)	Summed SAR (W/kg)
	Band	Scaled SAR (W/kg)	Scaled SAR (W/kg)	
Back	GSM850	1.280	0.171	1.451
Front	GSM850	1.030	0.098	1.128
Top side	GSM850	--	0.096	0.096
Bottom side	GSM850	0.080	--	0.080
Right side	GSM850	0.124	--	0.124
Left side	GSM850	0.111	0.101	0.212
Back	GSM1900	1.281	0.171	1.452
Front	GSM1900	1.057	0.098	1.155
Top side	GSM1900	--	0.096	0.096
Bottom side	GSM1900	0.977	--	0.977
Right side	GSM1900	0.612	--	0.612
Left side	GSM1900	0.589	0.101	0.690
Back	WCDMA Band 2	0.925	0.171	1.096
Front	WCDMA Band 2	0.782	0.098	0.880
Top side	WCDMA Band 2	--	0.096	0.096
Bottom side	WCDMA Band 2	0.723	--	0.723
Right side	WCDMA Band 2	0.353	--	0.353
Left side	WCDMA Band 2	0.331	0.101	0.432
Back	WCDMA Band 5	0.274	0.171	0.445
Front	WCDMA Band 5	0.214	0.098	0.312
Top side	WCDMA Band 5	--	0.096	0.096
Bottom side	WCDMA Band 5	0.022	--	0.022
Right side	WCDMA Band 5	0.066	--	0.066
Left side	WCDMA Band 5	0.054	0.101	0.155
Back	WCDMA Band 4	1.113	0.171	1.284
Front	WCDMA Band 4	0.743	0.098	0.841
Top side	WCDMA Band 4	--	0.096	0.096
Bottom side	WCDMA Band 4	0.961	--	0.961
Right side	WCDMA Band 4	0.455	--	0.455
Left side	WCDMA Band 4	0.446	0.101	0.547
Back	LTE Band 2	0.495	0.171	0.666
Front	LTE Band 2	0.405	0.098	0.503
Top side	LTE Band 2	--	0.096	0.096
Bottom side	LTE Band 2	1.030	--	1.030
Right side	LTE Band 2	0.224	--	0.224
Left side	LTE Band 2	0.199	0.101	0.300
Back	LTE Band 4	0.400	0.171	0.571
Front	LTE Band 4	0.332	0.098	0.430

Top side	LTE Band 4	--	0.096	0.096
Bottom side	LTE Band 4	0.731	--	0.731
Right side	LTE Band 4	0.166	--	0.166
Left side	LTE Band 4	0.162	0.101	0.263
Back	LTE Band 5	0.032	0.171	0.203
Front	LTE Band 5	0.007	0.098	0.105
Top side	LTE Band 5	--	0.096	0.096
Bottom side	LTE Band 5	0.012	--	0.012
Right side	LTE Band 5	0.005	--	0.005
Left side	LTE Band 5	0.004	0.101	0.105
Back	LTE Band 7	1.093	0.171	1.264
Front	LTE Band 7	0.697	0.098	0.795
Top side	LTE Band 7	--	0.096	0.096
Bottom side	LTE Band 7	0.567	--	0.567
Right side	LTE Band 7	0.373	--	0.373
Left side	LTE Band 7	0.353	0.101	0.454
Back	LTE Band 12	0.042	0.171	0.213
Front	LTE Band 12	0.022	0.098	0.120
Top side	LTE Band 12	--	0.096	0.096
Bottom side	LTE Band 12	0.010	--	0.010
Right side	LTE Band 12	0.012	--	0.012
Left side	LTE Band 12	0.011	0.101	0.112
Back	LTE Band 13	0.035	0.171	0.206
Front	LTE Band 13	0.007	0.098	0.105
Top side	LTE Band 13	--	0.096	0.096
Bottom side	LTE Band 13	0.012	--	0.012
Right side	LTE Band 13	0.020	--	0.020
Left side	LTE Band 13	0.018	0.101	0.119
Back	LTE Band 17	0.036	0.171	0.207
Front	LTE Band 17	0.021	0.098	0.119
Top side	LTE Band 17	--	0.096	0.096
Bottom side	LTE Band 17	0.009	--	0.009
Right side	LTE Band 17	0.020	--	0.020
Left side	LTE Band 17	0.018	0.101	0.119
Back	LTE Band 25	0.582	0.171	0.753
Front	LTE Band 25	0.414	0.098	0.512
Top side	LTE Band 25	--	0.096	0.096
Bottom side	LTE Band 25	0.998	--	0.998
Right side	LTE Band 25	0.333	--	0.333
Left side	LTE Band 25	0.319	0.101	0.420
Back	LTE Band 26	0.057	0.171	0.228
Front	LTE Band 26	0.013	0.098	0.111
Top side	LTE Band 26	--	0.096	0.096

Bottom side	LTE Band 26	0.025	--	0.025
Right side	LTE Band 26	0.014	--	0.014
Left side	LTE Band 26	0.012	0.101	0.113
Back	LTE Band 30	0.357	0.171	0.528
Front	LTE Band 30	0.331	0.098	0.429
Top side	LTE Band 30	--	0.096	0.096
Bottom side	LTE Band 30	0.329	--	0.329
Right side	LTE Band 30	0.216	--	0.216
Left side	LTE Band 30	0.204	0.101	0.305
Back	LTE Band 40	0.126	0.171	0.297
Front	LTE Band 40	0.092	0.098	0.190
Top side	LTE Band 40	--	0.096	0.096
Bottom side	LTE Band 40	0.120	--	0.120
Right side	LTE Band 40	0.088	--	0.088
Left side	LTE Band 40	0.083	0.101	0.184
Back	LTE Band 66	0.586	0.171	0.757
Front	LTE Band 66	0.401	0.098	0.499
Top side	LTE Band 66	--	0.096	0.096
Bottom side	LTE Band 66	0.852	--	0.852
Right side	LTE Band 66	0.313	--	0.313
Left side	LTE Band 66	0.291	0.101	0.392

10. Measurement Uncertainty

10.1 Uncertainty for EUT SAR Test

a	b	c	d	e= f(d,k)	f	g	h= c*f/e	i= c*g/e	k
Uncertainty Component	Sec.	Tol (+- %)	Prob. Dist.	Div.	Ci (1g)	Ci (10g)	1g Ui (+- %)	10g Ui (+- %)	Vi
Measurement System									
Probe calibration	E.2.1	7.0	N	1	1	1	7.00	7.00	∞
Axial Isotropy	E.2.2	2.5	R	$\sqrt{3}$	$(1_{Cp})^{1/2}$	$(1_{Cp})^{1/2}$	1.02	1.02	∞
Hemispherical Isotropy	E.2.2	4.0	R	$\sqrt{3}$	$(Cp)^{1/2}$	$(Cp)^{1/2}$	1.63	1.63	∞
Boundary effect	E.2.3	1.0	R	$\sqrt{3}$	1	1	0.58	0.58	∞
Linearity	E.2.4	5.0	R	$\sqrt{3}$	1	1	2.89	2.89	∞
System detection limits	E.2.5	1.0	R	$\sqrt{3}$	1	1	0.58	0.58	∞
Readout Electronics	E.2.6	0.02	N	1	1	1	0.02	0.02	∞
Reponse Time	E.2.7	3.0	R	$\sqrt{3}$	1	1	1.73	1.73	∞
Integration Time	E.2.8	2.0	R	$\sqrt{3}$	1	1	1.15	1.15	∞
RF ambient Conditions – Noise	E.6.1	3.0	R	$\sqrt{3}$	1	1	1.73	1.73	∞
RF ambient Conditions - Reflections	E.6.1	3.0	R	$\sqrt{3}$	1	1	1.73	1.73	∞
Probe positioner Mechanical Tolerance	E.6.2	2.0	R	$\sqrt{3}$	1	1	1.15	1.15	∞
Probe positioning with respect to Phantom Shell	E.6.3	0.05	R	$\sqrt{3}$	1	1	0.03	0.03	∞
Extrapolation, interpolation and integration Algorithms for Max. SAR Evaluation	E.5	5.0	R	$\sqrt{3}$	1	1	2.89	2.89	∞
Test Sample Related									
Test sample positioning	E.4.2	0.03	N	1	1	1	0.03	0.03	N-1
Device Holder Uncertainty	E.4.1	5.00	N	1	1	1	5.00	5.00	
Output power Variation - SAR drift measurement	E.2.9	12.02	R	$\sqrt{3}$	1	1	6.94	6.94	∞
SAR scaling	E6.5	0.0	R	$\sqrt{3}$	1	1	0.0	0.0	∞
Phantom and Tissue Parameters									
Phantom Uncertainty (Shape and thickness tolerances)	E.3.1	0.05	R	$\sqrt{3}$	1	1	0.03	0.03	∞
Uncertainty in SAR correction for deviations in permittivity and conductivity	E3.2	1.9	R	$\sqrt{3}$	1	0.84	1.10	0.90	∞
Liquid conductivity - deviation	E.3.2	5.00	R	$\sqrt{3}$	0.64	0.43	1.85	1.24	∞

from target value										
Liquid conductivity measurement uncertainty	E.3.3	5.00	N	1	0.64	0.43	3.20	2.15	∞	
Liquid permittivity - deviation from target value	E.3.2	0.37	R	$\sqrt{3}$	0.6	0.49	0.13	0.10	∞	
Liquid permittivity measurement uncertainty	E.3.3	10.00	N	1	0.6	0.49	6.00	4.90	∞	
Combined Standard Uncertainty			RSS				12.98	12.53		
Expanded Uncertainty (95% Confidence interval)			K=2				25.32	24.43		

10.2 Uncertainty for System Performance Check

a	b	c	d	e= f(d,k)	f	g	h= c*f/e	i= c*g/e	k
Uncertainty Component	Sec.	Tol (+- %)	Prob. Dist.	Div.	Ci (1g)	Ci (10g)	1g Ui (+- %)	10g Ui (+- %)	Vi
Measurement System									
Probe calibration	E.2.1	7.0	N	1	1	1	7.00	7.00	∞
Axial Isotropy	E.2.2	2.5	R	$\sqrt{3}$	$(1_{Cp})^{1/2}$	$(1_{Cp})^{1/2}$	1.02	1.02	∞
Hemispherical Isotropy	E.2.2	4.0	R	$\sqrt{3}$	$(Cp)^{1/2}$	$(Cp)^{1/2}$	1.63	1.63	∞
Boundary effect	E.2.3	1.0	R	$\sqrt{3}$	1	1	0.58	0.58	∞
Linearity	E.2.4	5.0	R	$\sqrt{3}$	1	1	2.89	2.89	∞
System detection limits	E.2.5	1.0	R	$\sqrt{3}$	1	1	0.58	0.58	∞
Modulation response	E.2.5	0	R	$\sqrt{3}$	0	0	0.0	0.0	∞
Readout Electronics	E.2.6	0.02	N	1	1	1	0.02	0.02	∞
Reponse Time	E.2.7	3.0	R	$\sqrt{3}$	1	1	1.73	1.73	∞
Integration Time	E.2.8	2.0	R	$\sqrt{3}$	1	1	1.15	1.15	∞
RF ambient Conditions – Noise	E.6.1	3.0	R	$\sqrt{3}$	1	1	1.73	1.73	∞
RF ambient Conditions - Reflections	E.6.1	3.0	R	$\sqrt{3}$	1	1	1.73	1.73	∞
Probe positioner Mechanical Tolerance	E.6.2	2.0	R	$\sqrt{3}$	1	1	1.15	1.15	∞
Probe positioning with respect to Phantom Shell	E.6.3	0.05	R	$\sqrt{3}$	1	1	0.03	0.03	∞
Extrapolation, interpolation and integration Algorithms for Max.	E.5.2	5.0	R	$\sqrt{3}$	1	1	2.89	2.89	∞

SAR Evaluation									
Dipole									
Dipole axis to liquid Distance	8,E.4.2	1.00	N	$\sqrt{3}$	1	1	0.58	0.58	N-1
Input power and SAR drift measurement	8,6.6.2	12.02	R	$\sqrt{3}$	1	1	6.94	6.94	∞
Deviation of experimental dipole from numerical dipole	E.6.4	5.5	R	$\sqrt{3}$	1	1	3.20	3.20	∞
Phantom and Tissue Parameters									
Phantom Uncertainty (Shape and thickness tolerances)	E.3.1	0.05	R	$\sqrt{3}$	1	1	0.03	0.03	∞
Uncertainty in SAR correction for deviations in permittivity and conductivity	E3.2	2.0	R	$\sqrt{3}$	1	0.84	1.10	1.10	∞
Liquid conductivity - deviation from target value	E.3.2	5.00	R	$\sqrt{3}$	0.64	0.43	1.85	1.24	
Liquid conductivity - measurement uncertainty	E.3.3	5.00	N	1	0.64	0.43	3.20	2.15	
Liquid permittivity - deviation from target value	E.3.2	0.37	R	$\sqrt{3}$	0.6	0.49	0.13	0.10	
Liquid permittivity - measurement uncertainty	E.3.3	10.00	N	1	0.6	0.49	6.00	4.90	M
Combined Standard Uncertainty			RSS				12.00	11.50	
Expanded Uncertainty (95% Confidence interval)			K=2				23.39	22.43	

Annex A. Plots of System Performance Check

MEASUREMENT 1

For Head Liquid

Type: Validation measurement (Fast, 75.00 %)

Date of measurement: 09/16/2019

Measurement duration: 7 minutes 21 seconds

E-field Probe: SSE5 - SN 09/13 EP168; ConvF: 6.99; Calibrated: 05/22/2019

A. Experimental conditions

Area Scan	dx=8mm dy=8mm
Phantom	Validation plane
Device Position	Dipole
Band	CW750
Signal	Duty Cycle 1:1

B. SAR Measurement Results

Frequency (MHz)	750.000000
Relative Permittivity (real part)	41.320574
Conductivity (S/m)	0.862373
Power Variation (%)	0.038363
Ambient Temperature	21.1
Liquid Temperature	21.3

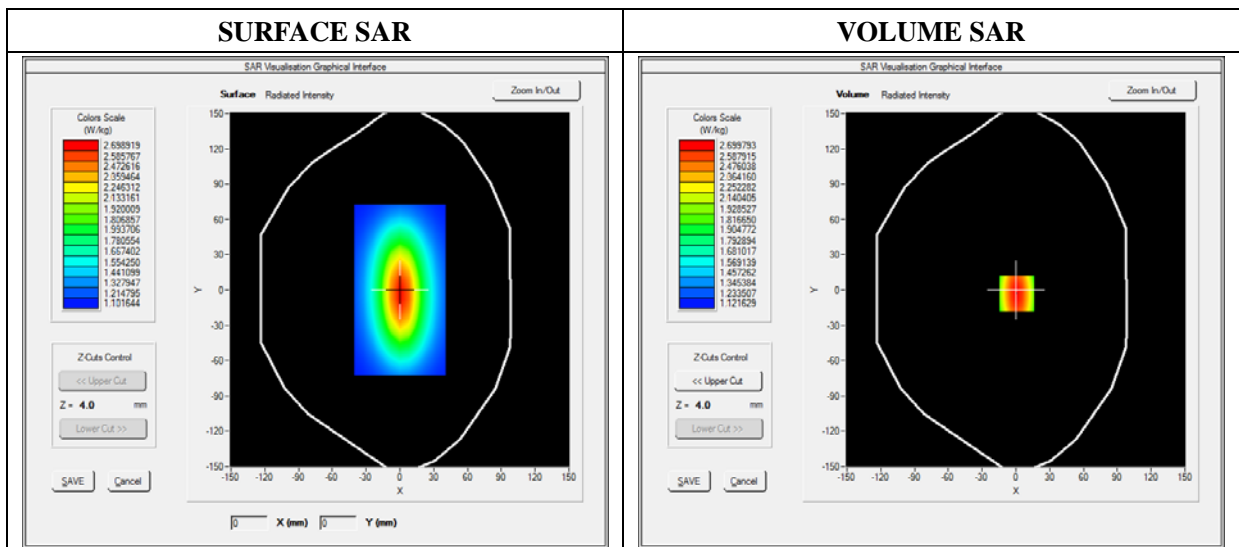

Maximum location: X=0.00, Y=0.00

SAR 10g (W/Kg)	1.042744
SAR 1g (W/Kg)	2.164534

Z Axis Scan

Z (mm)	0.00	4.00	9.00	14.00	19.00	24.00	29.00
SAR (W/Kg)	0.0000	2.3634	1.8023	1.4523	1.2514	1.1005	1.0245

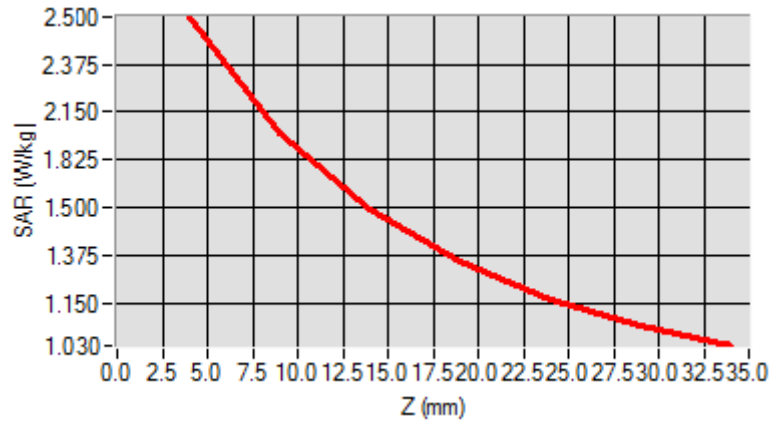

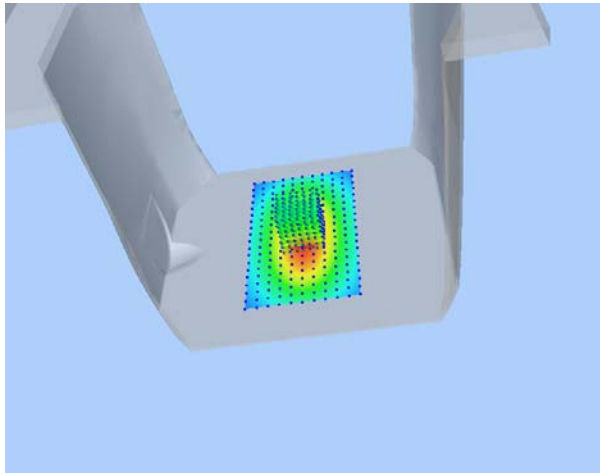
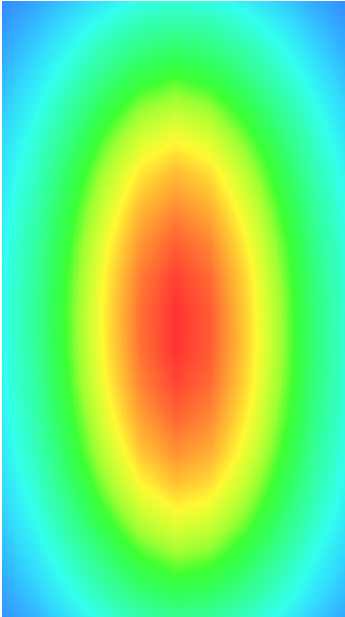
3D screen shot	Hot spot position
	

MEASUREMENT 2

For Head Liquid

Type: Validation measurement (Fast, 75.00 %)

Date of measurement: 09/16/2019

Measurement duration: 7 minutes 21 seconds

E-field Probe: SSE5 - SN 09/13 EP168; ConvF: 6.93; Calibrated: 05/22/2019

A. Experimental conditions

Area Scan	dx=8mm dy=8mm
Phantom	Validation plane
Device Position	Dipole
Band	CW835
Signal	Duty Cycle 1:1

B. SAR Measurement Results

Frequency (MHz)	835.000000
Relative Permittivity (real part)	41.110245
Conductivity (S/m)	0.871245
Power Variation (%)	0.038437
Ambient Temperature	21.1
Liquid Temperature	21.3

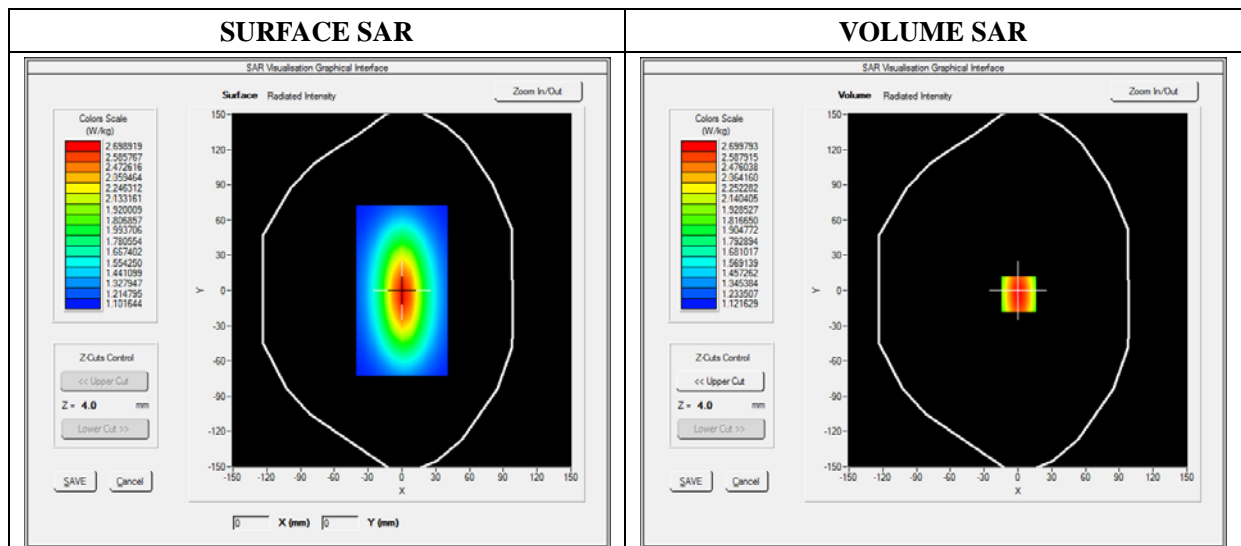

Maximum location: X=0.00, Y=0.00

SAR 10g (W/Kg)	1.519489
SAR 1g (W/Kg)	2.411253

Z Axis Scan

Z (mm)	0.00	4.00	9.00	14.00	19.00	24.00	29.00
SAR (W/Kg)	0.0000	2.4900	1.8942	1.4811	1.3541	1.1123	1.0539

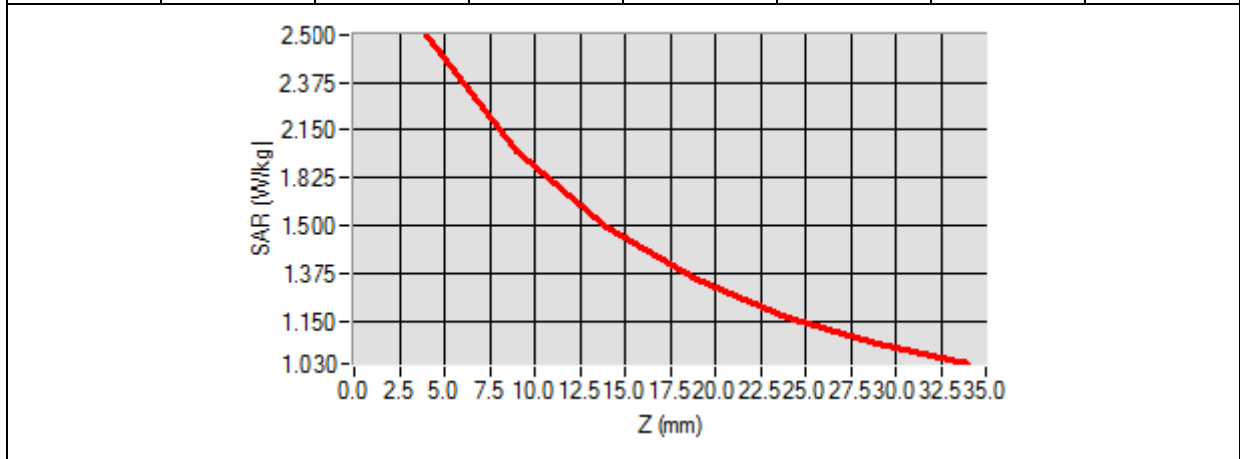

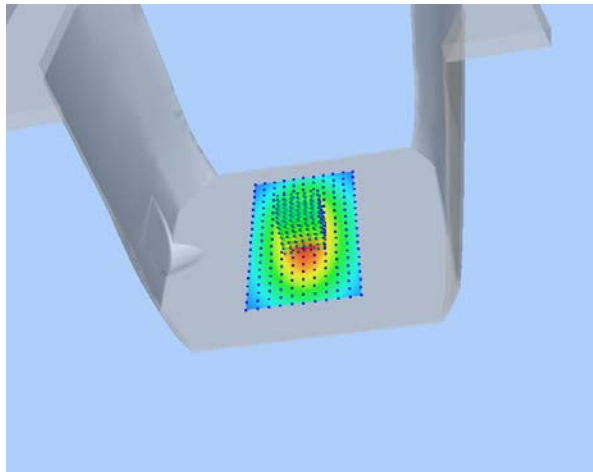
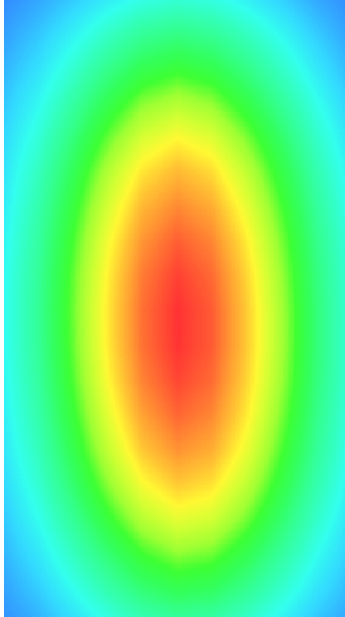
3D screen shot	Hot spot position
	

MEASUREMENT 3

For Head Liquid

Type: Validation measurement (Fast, 75.00 %)

Date of measurement: 09/17/2019

Measurement duration: 12 minutes 21 seconds

E-field Probe: SSE5 - SN 09/13 EP168; ConvF: 5.84; Calibrated: 05/22/2019

A. Experimental conditions

Area Scan	dx=8mm dy=8mm
Phantom	Validation plane
Device Position	Dipole
Band	CW1800
Signal	CW (Crest factor: 1.0)

B. SAR Measurement Results

Frequency (MHz)	1800.000000
Relative Permittivity (real part)	39.024890
Conductivity (S/m)	1.371250
Power Variation (%)	1.401232
Ambient Temperature	21.1
Liquid Temperature	21.2

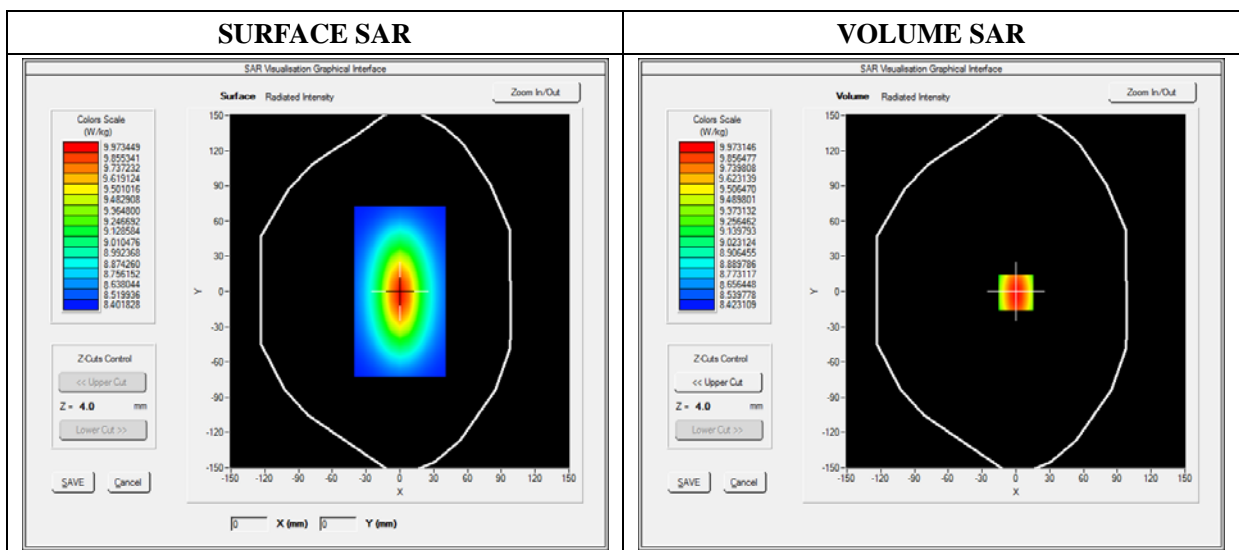

Maximum location: X=0.00, Y=0.00

SAR 10g (W/Kg)	5.171252
SAR 1g (W/Kg)	9.611250

Z Axis Scan

Z (mm)	0.00	4.00	9.00	14.00	19.00	24.00	29.00
SAR (W/Kg)	0.0000	10.3455	7.1125	5.1026	3.425	3.0242	2.1125

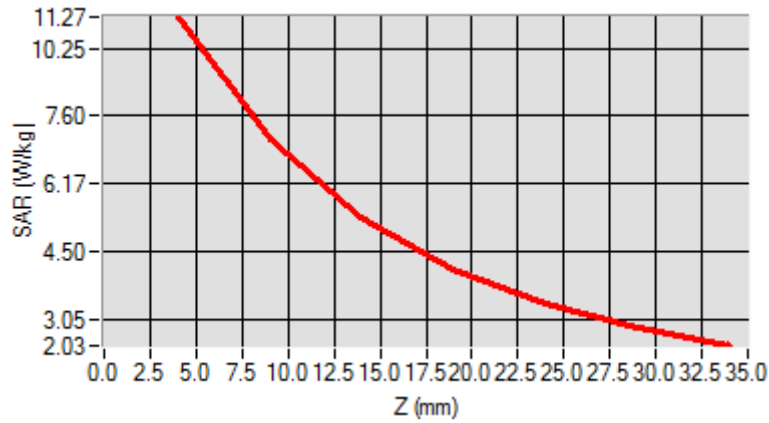

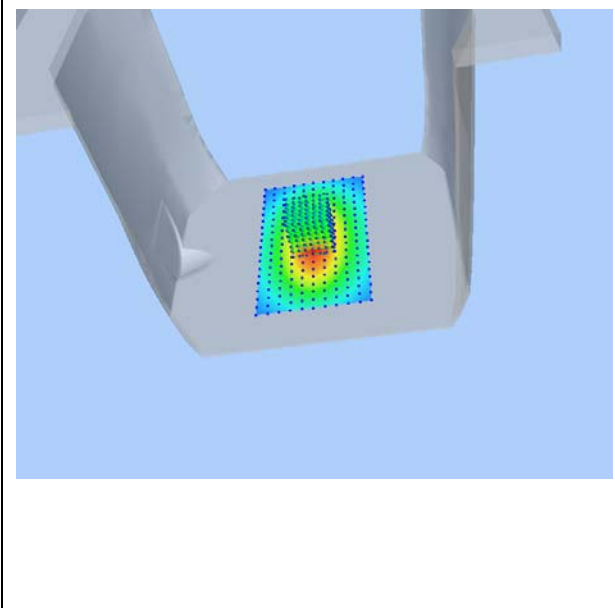
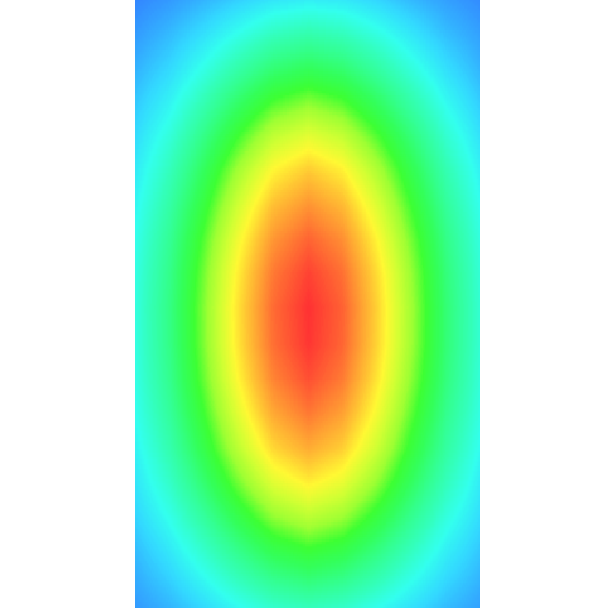
3D screen shot	Hot spot position
	

MEASUREMENT 4

For Head Liquid

Type: Validation measurement (Fast, 75.00 %)

Date of measurement: 09/17/2019

Measurement duration: 12 minutes 21 seconds

E-field Probe: SSE5 - SN 09/13 EP168; ConvF: 6.35; Calibrated: 05/22/2019

A. Experimental conditions

Area Scan	dx=8mm dy=8mm
Phantom	Validation plane
Device Position	Dipole
Band	CW1900
Signal	Duty Cycle 1:1

B. SAR Measurement Results

Frequency (MHz)	1900.000000
Relative Permittivity (real part)	38.560124
Conductivity (S/m)	1.380369
Power Variation (%)	1.022540
Ambient Temperature	21.1
Liquid Temperature	21.3

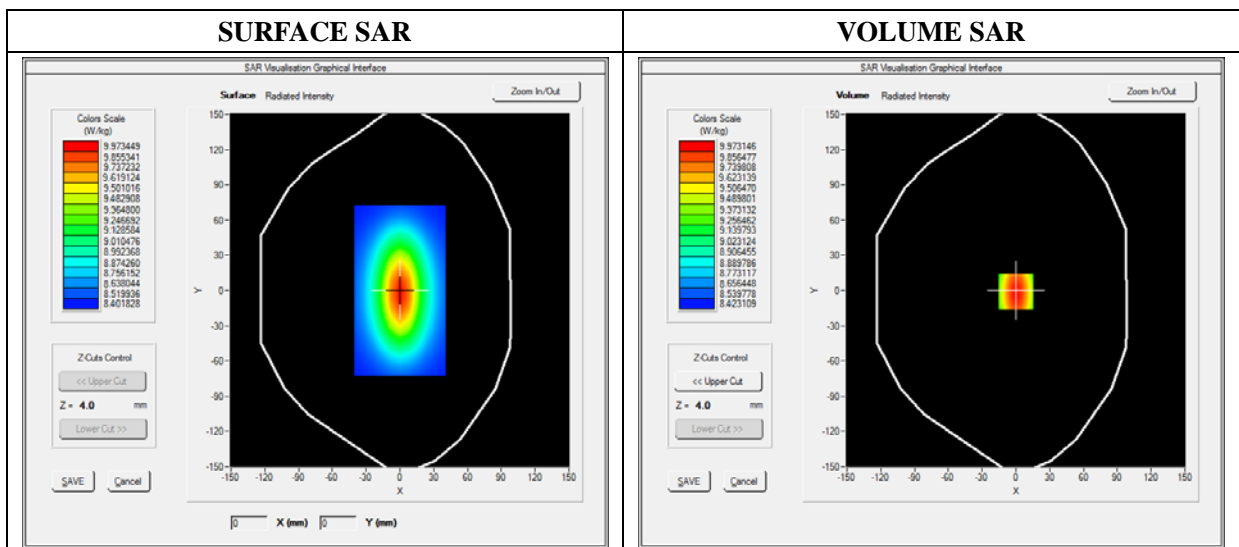

Maximum location: X=0.00, Y=0.00

SAR 10g (W/Kg)	5.174526
SAR 1g (W/Kg)	9.913214

Z Axis Scan

Z (mm)	0.00	4.00	9.00	14.00	19.00	24.00	29.00
SAR (W/Kg)	0.0000	10.2354	6.8400	5.0121	4.1189	3.0522	2.8424

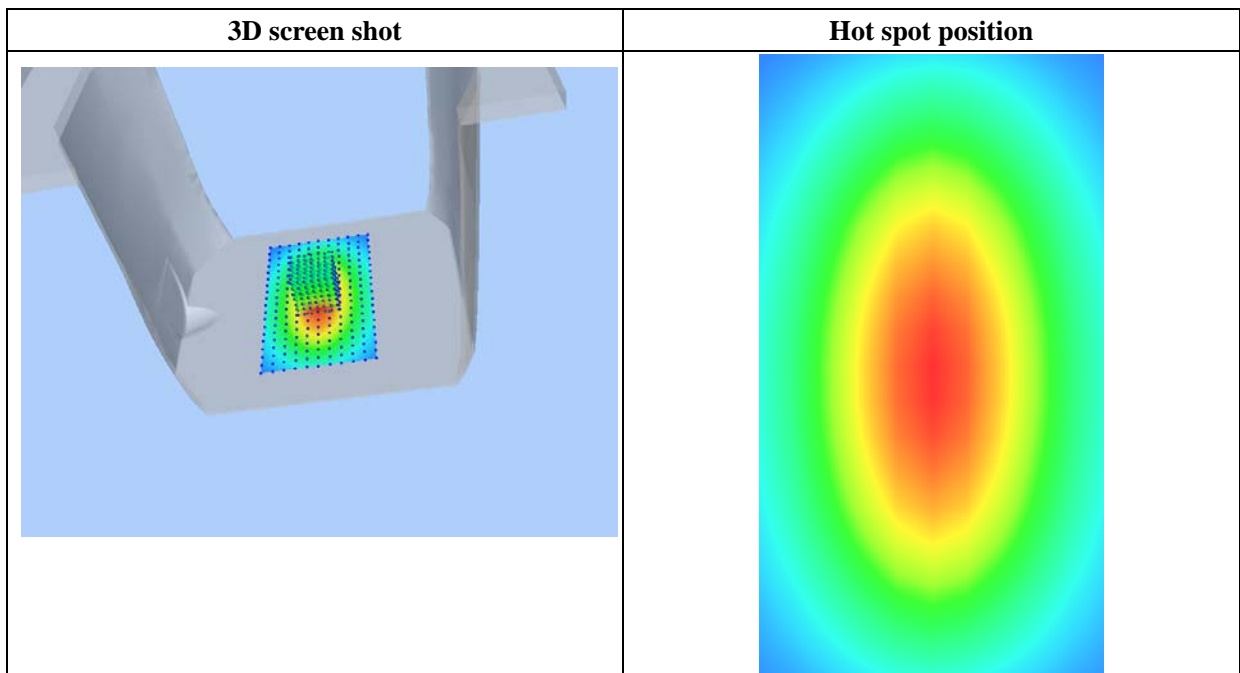
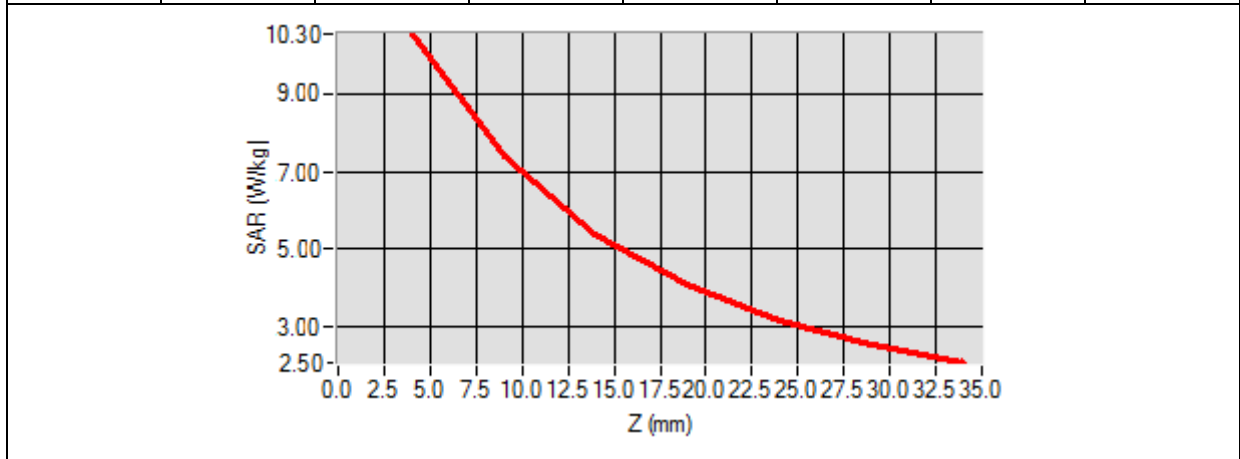

MEASUREMENT 5

For Head Liquid

Type: Validation measurement (Fast, 75.00 %)

Date of measurement: 09/18/2019

Measurement duration: 12 minutes 21 seconds

E-field Probe: SSE5 - SN 09/13 EP168; ConvF: 5.64; Calibrated: 05/22/2019

A. Experimental conditions

Area Scan	dx=8mm dy=8mm
Phantom	Validation plane
Device Position	Dipole
Band	CW2450
Signal	Duty Cycle 1:1

B. SAR Measurement Results

Frequency (MHz)	2450.000000
Relative Permittivity (real part)	38.153660
Conductivity (S/m)	1.740236
Power Variation (%)	1.141452
Ambient Temperature	21.1
Liquid Temperature	21.2

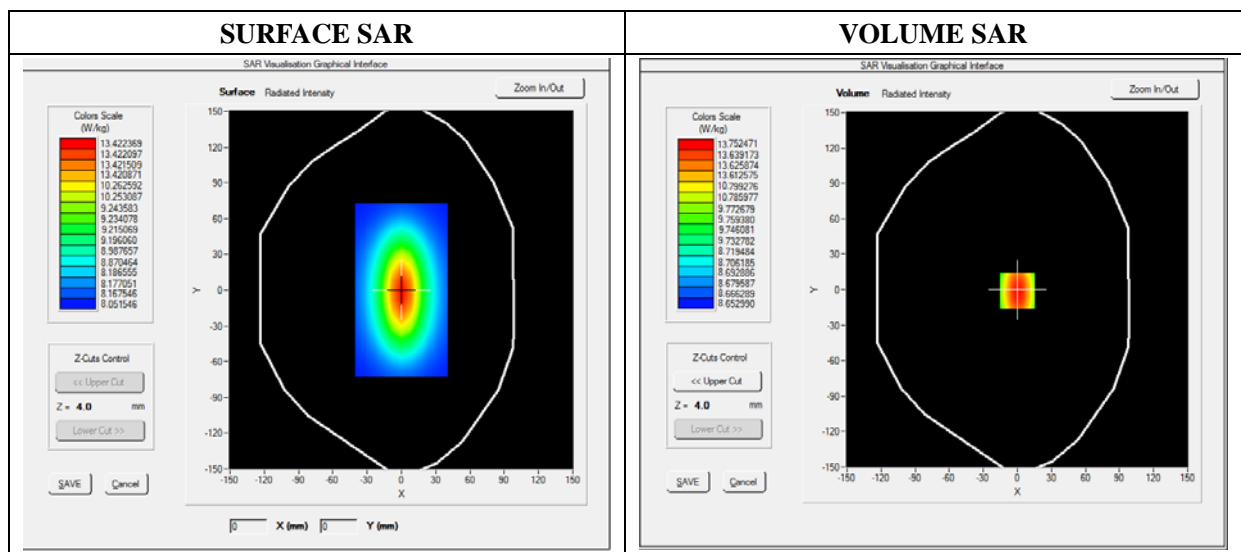

Maximum location: X=0.00, Y=0.00

SAR 10g (W/Kg)	8.020427
SAR 1g (W/Kg)	13.452457

Z Axis Scan

Z (mm)	0.00	4.00	9.00	14.00	19.00	24.00	29.00
SAR (W/Kg)	0.0000	14.1034	12.0012	10.2624	7.4715	5.9022	4.5114

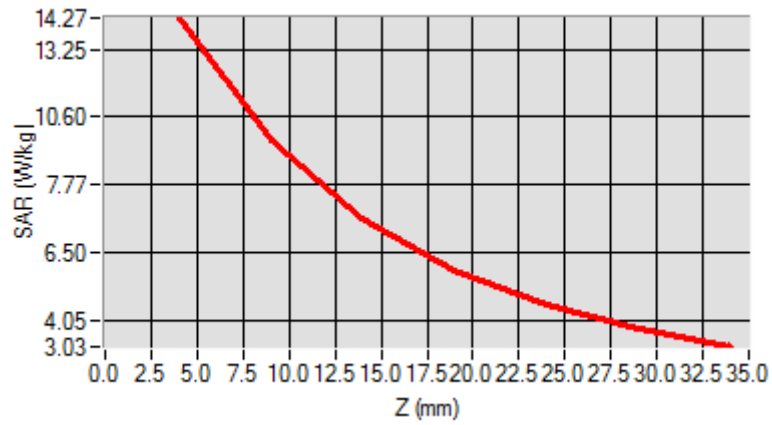

3D screen shot

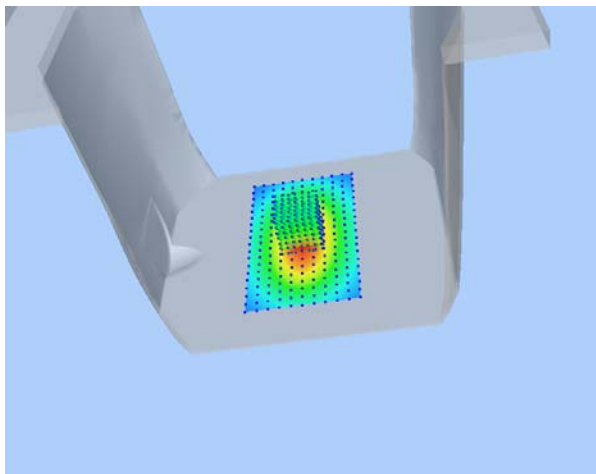

Hot spot position

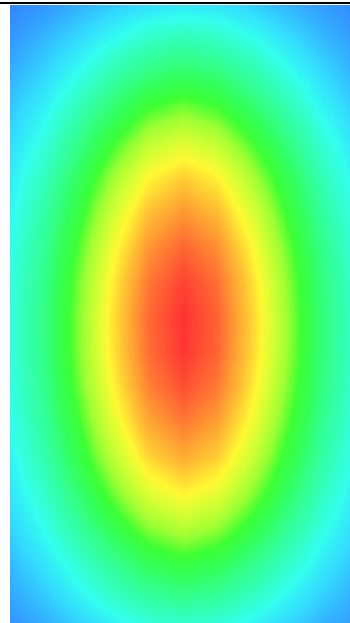

MEASUREMENT 6

For Head Liquid

Type: Validation measurement (Fast, 75.00 %)

Date of measurement: 09/18/2019

Measurement duration: 12 minutes 21 seconds

E-field Probe: SSE5 - SN 09/13 EP168; ConvF: 5.37; Calibrated: 05/22/2019

A. Experimental conditions

Area Scan	dx=8mm dy=8mm
Phantom	Validation plane
Device Position	Dipole
Band	CW2600
Signal	Duty Cycle 1:1

B. SAR Measurement Results

Frequency (MHz)	2600.000000
Relative Permittivity (real part)	38.631092
Conductivity (S/m)	1.930182
Power Variation (%)	1.028221
Ambient Temperature	21.1
Liquid Temperature	21.2

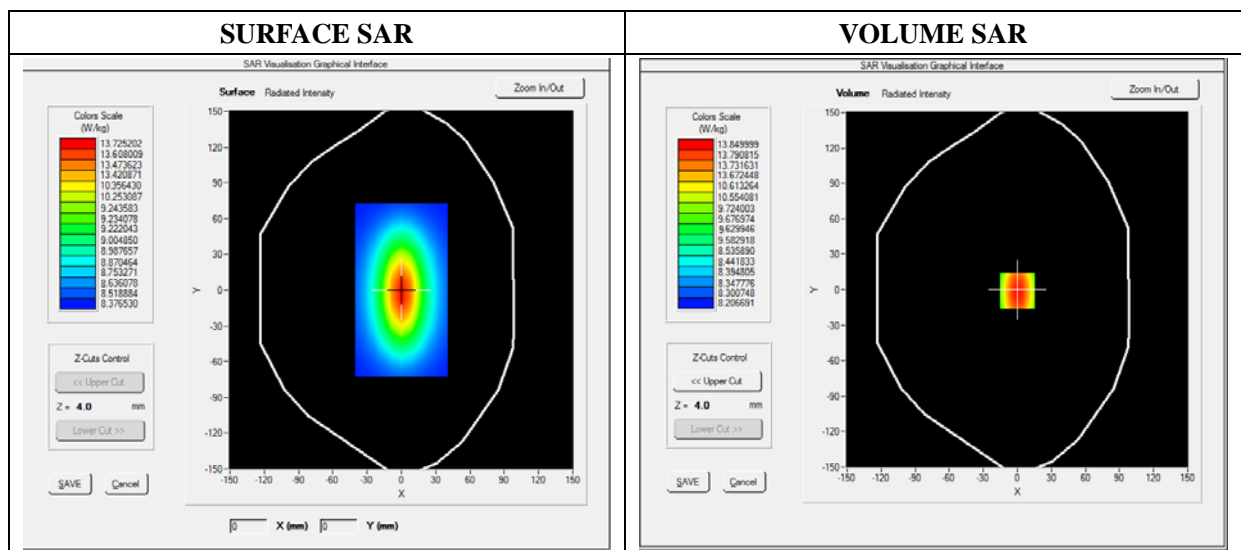

Maximum location: X=0.00, Y=0.00

SAR 10g (W/Kg)	8.270822
SAR 1g (W/Kg)	13.670282

Z Axis Scan

Z (mm)	0.00	4.00	9.00	14.00	19.00	24.00	29.00
SAR (W/Kg)	0.0000	14.0426	12.1354	10.2965	7.4854	5.9354	4.5186

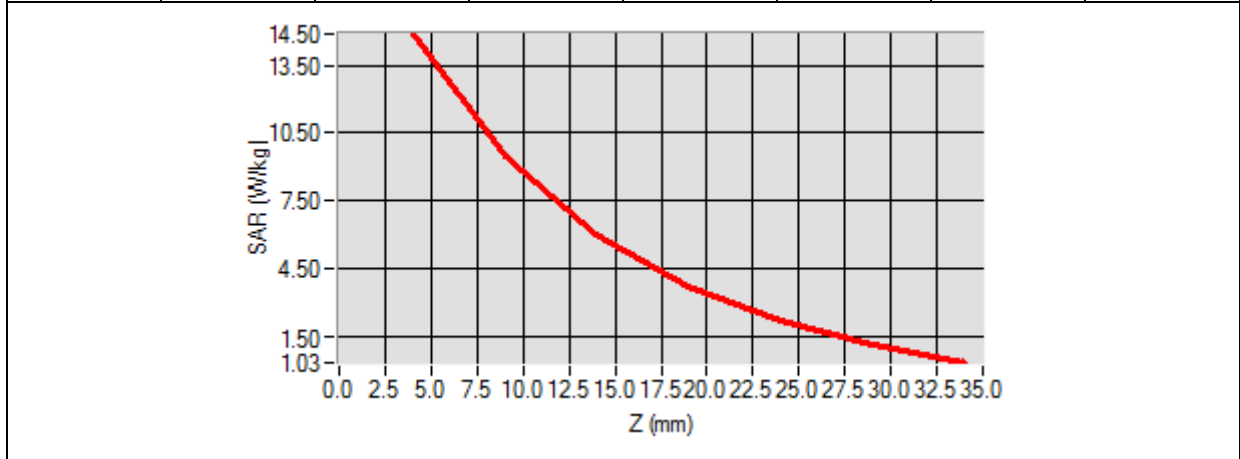

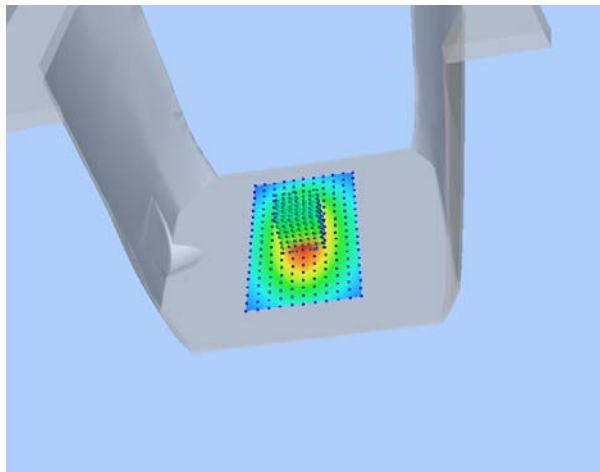
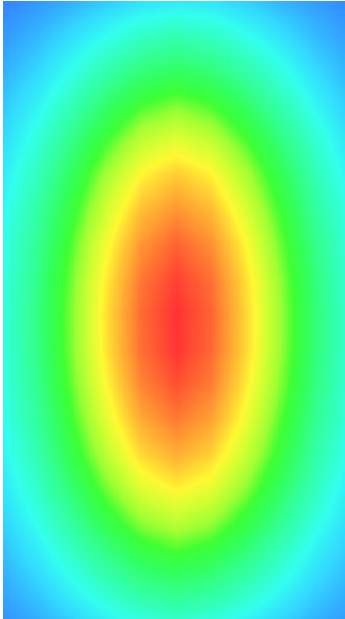
3D screen shot	Hot spot position
	

MEASUREMENT 7

For Head Liquid

Type: Validation measurement (Fast, 75.00 %)

Date of measurement: 09/19/2019

Measurement duration: 12 minutes 21 seconds

E-field Probe: SSE2 - SN 45/15 EPGO280; ConvF: 2.28; Calibrated: 2019/07/08

A. Experimental conditions

Area Scan	dx=8mm dy=8mm
Phantom	Validation plane
Device Position	Dipole
Band	CW5200
Signal	CW (Crest factor: 1.0)

B. SAR Measurement Results

Frequency (MHz)	5200.000000
Relative Permittivity (real part)	35.612911
Conductivity (S/m)	4.871483
Power Variation (%)	0.943213
Ambient Temperature	21.1
Liquid Temperature	21.2

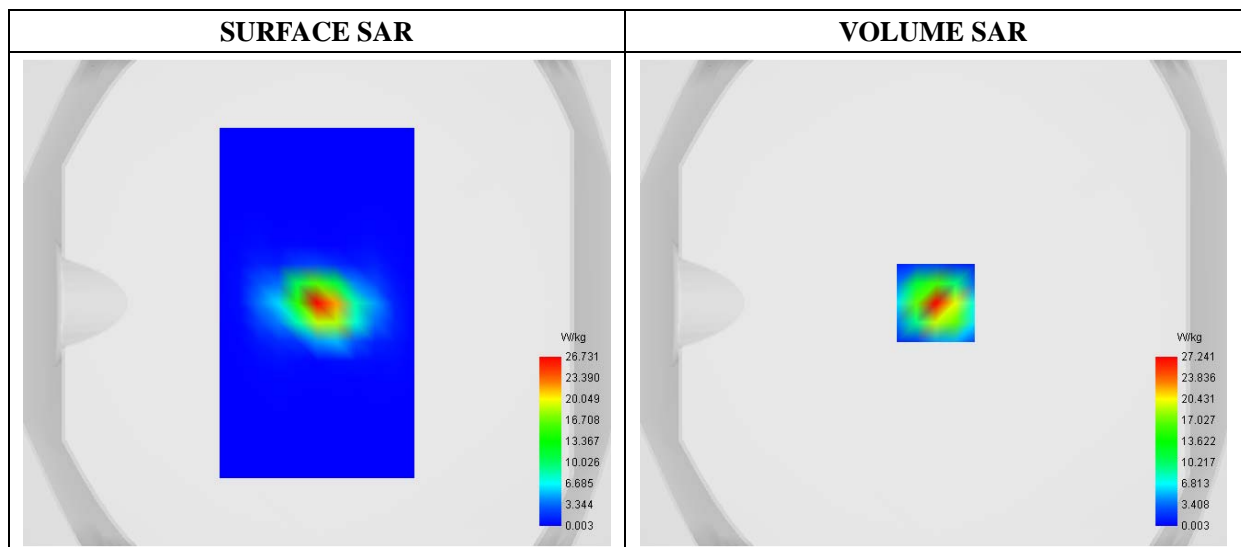

Maximum location: X=1.00, Y=0.00

SAR 10g (W/Kg)	5.310334
SAR 1g (W/Kg)	16.946226

Z (mm)	0.00	2.00	7.00	12.00	17.00	22.00	27.00
SAR (W/Kg)	41.7264	27.2408	6.5746	1.6234	0.3765	0.0793	0.0129

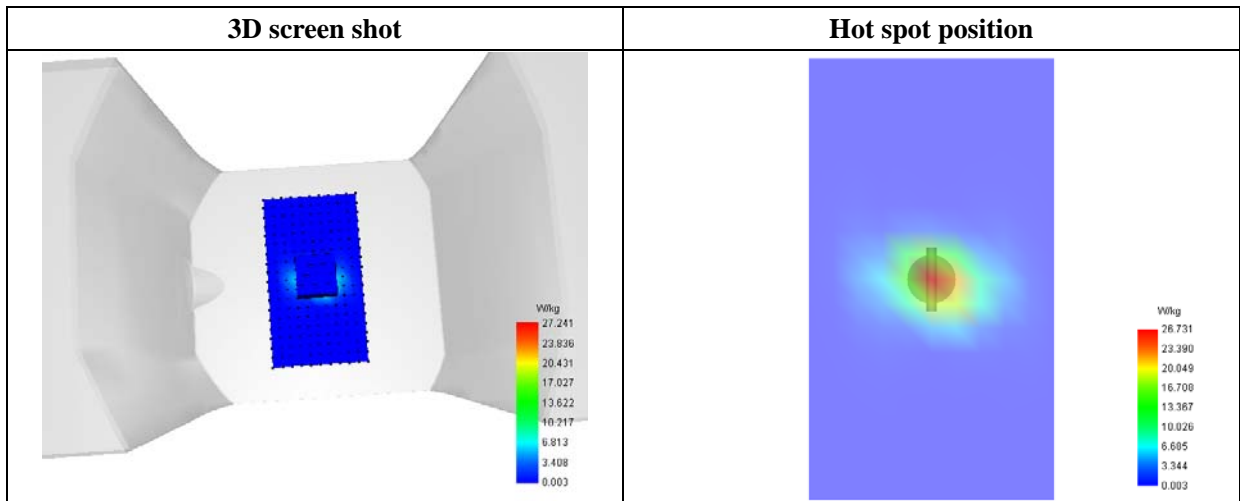
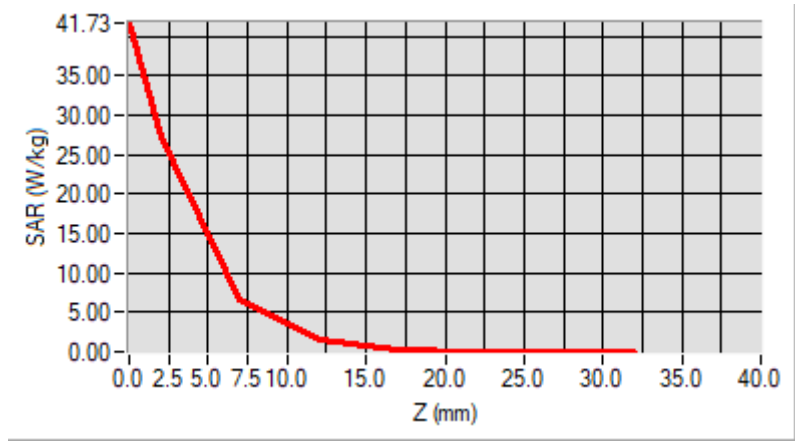

MEASUREMENT 8

For Head Liquid

Type: Validation measurement (Fast, 75.00 %)

Date of measurement: 2019/09/19

Measurement duration: 12 minutes 21 seconds

E-field Probe: SSE2 - SN 45/15 EPGO280; ConvF: 2.44; Calibrated: 2017/09/18

A. Experimental conditions

Area Scan	dx=8mm dy=8mm
Phantom	Validation plane
Device Position	Dipole
Band	CW5800
Signal	CW (Crest factor: 1.0)

B. SAR Measurement Results

Frequency (MHz)	5800.000000
Relative Permittivity (real part)	35.612911
Conductivity (S/m)	5.171483
Power Variation (%)	0.943782
Ambient Temperature	21.1
Liquid Temperature	21.2

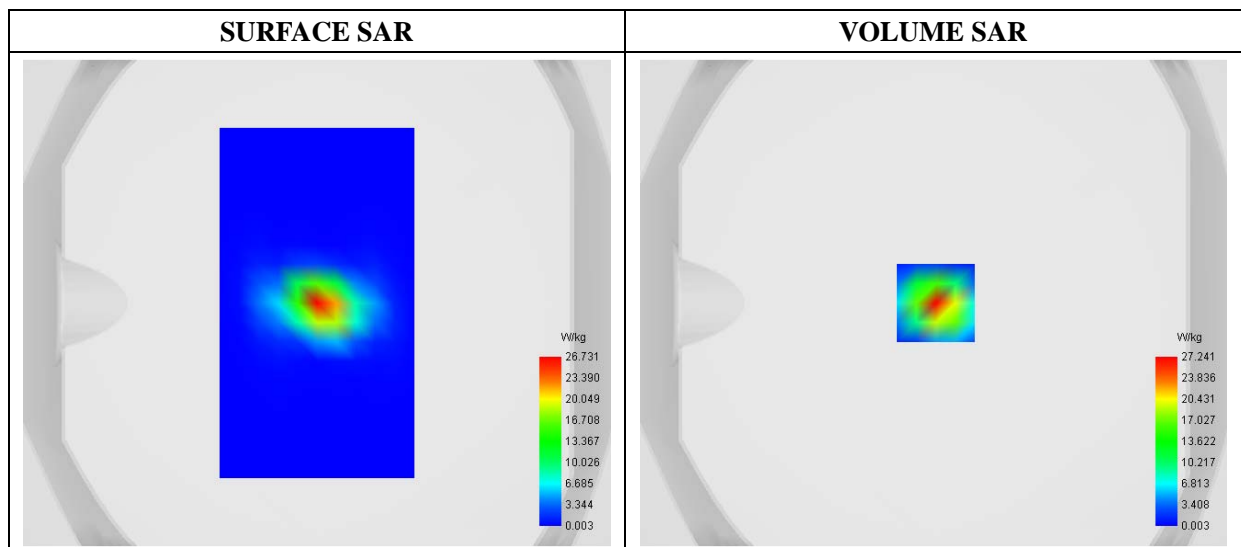

Maximum location: X=1.00, Y=0.00

SAR 10g (W/Kg)	5.310334
SAR 1g (W/Kg)	16.946226

Z (mm)	0.00	2.00	7.00	12.00	17.00	22.00	27.00
SAR (W/Kg)	41.7264	27.2408	6.5746	1.6234	0.3765	0.0793	0.0129

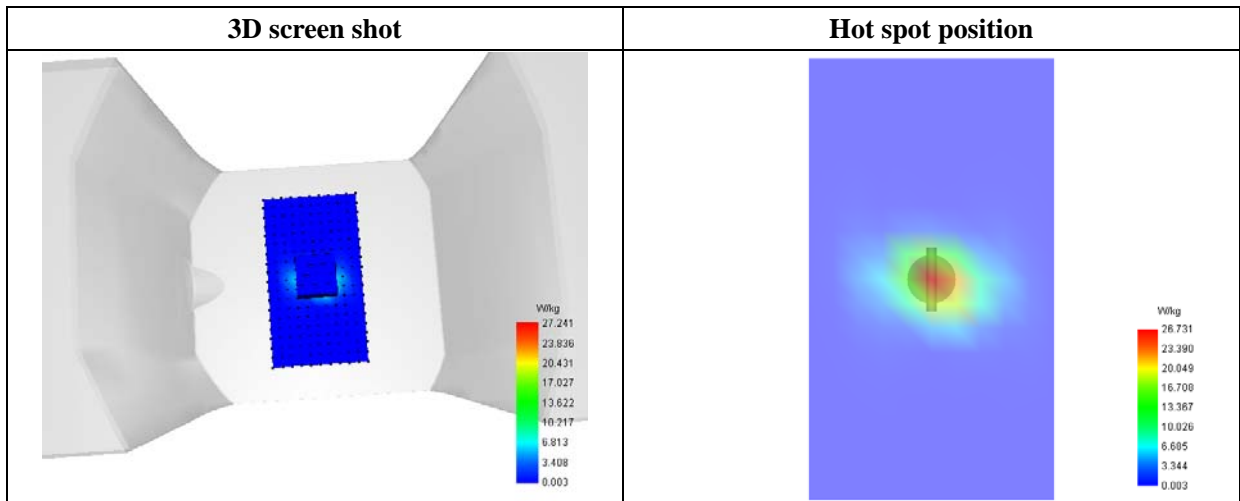
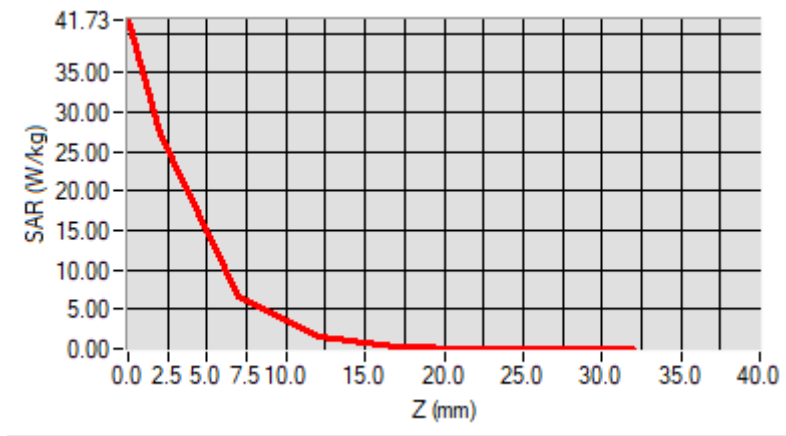

MEASUREMENT 9

For Body Liquid

Type: Validation measurement (Fast, 75.00 %)

Date of measurement: 09/16/2019

Measurement duration: 12 minutes 21 seconds

E-field Probe: SSE5 - SN 09/13 EP168; ConvF: 7.28; Calibrated: 05/22/2019

A. Experimental conditions

Area Scan	dx=8mm dy=8mm
Phantom	Validation plane
Device Position	Dipole
Band	CW750
Signal	Duty Cycle 1:1

B. SAR Measurement Results

Frequency (MHz)	750.000000
Relative Permittivity (real part)	54.964739
Conductivity (S/m)	0.931048
Power Variation (%)	0.034745
Ambient Temperature	21.1
Liquid Temperature	21.3

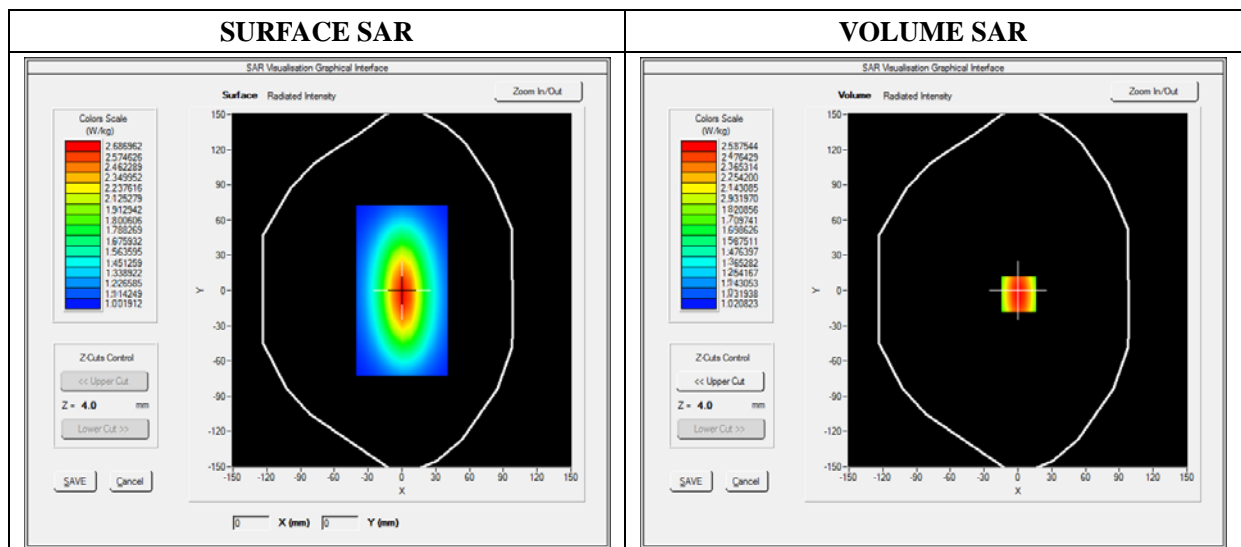

Maximum location: X=0.00, Y=0.00

SAR 10g (W/Kg)	1.000865
SAR 1g (W/Kg)	2.124211

Z Axis Scan

Z (mm)	0.00	4.00	9.00	14.00	19.00	24.00	29.00
SAR (W/Kg)	0.0000	2.5132	1.1087	0.8214	0.5160	0.4875	0.4864

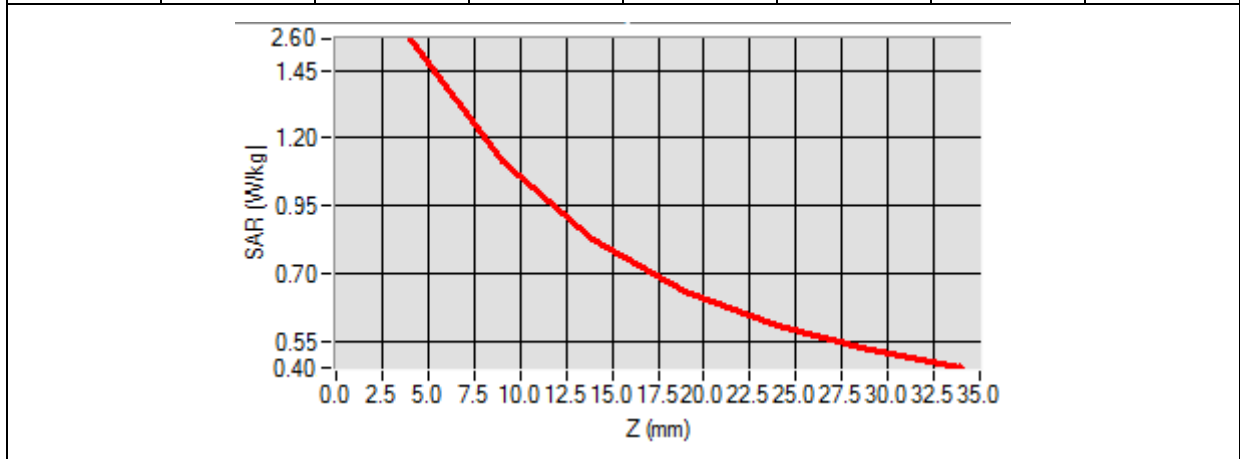

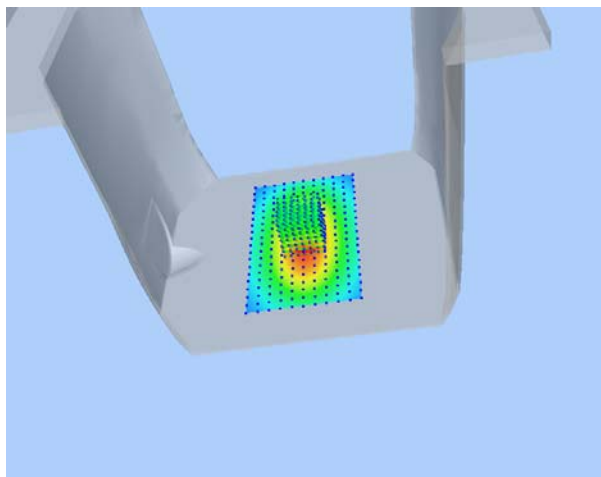
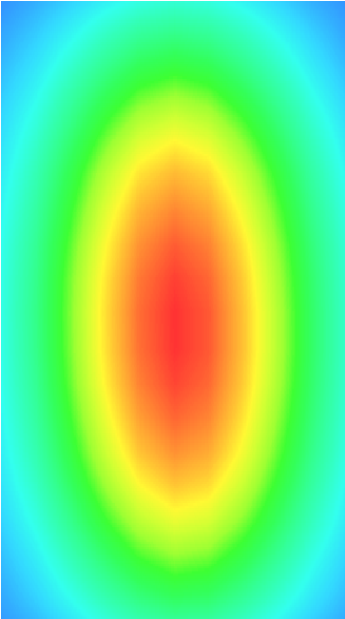
3D screen shot	Hot spot position
	

MEASUREMENT 10

For Body Liquid

Type: Validation measurement (Fast, 75.00 %)

Date of measurement: 09/16/2019

Measurement duration: 12 minutes 21 seconds

E-field Probe: SSE5 - SN 09/13 EP168; ConvF: 7.13; Calibrated: 05/22/2019

A. Experimental conditions

Area Scan	dx=8mm dy=8mm
Phantom	Validation plane
Device Position	Dipole
Band	CW835
Signal	Duty Cycle 1:1

B. SAR Measurement Results

Frequency (MHz)	835.000000
Relative Permittivity (real part)	54.851214
Conductivity (S/m)	0.951454
Power Variation (%)	0.901472
Ambient Temperature	21.1
Liquid Temperature	21.3

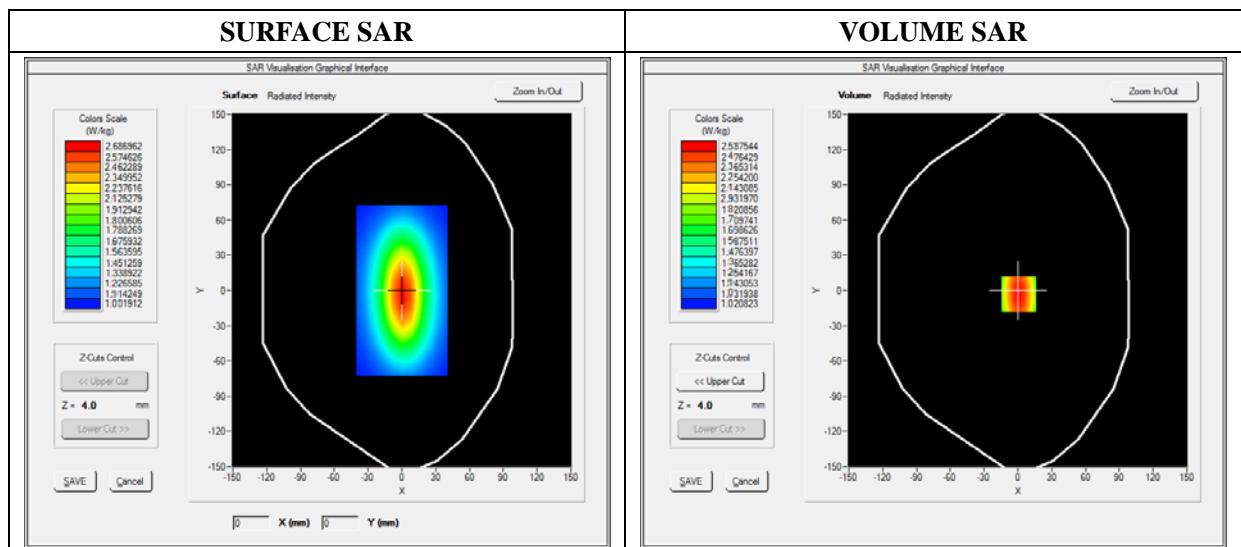

Maximum location: X=0.00, Y=0.00

SAR 10g (W/Kg)	1.028956
SAR 1g (W/Kg)	2.354211

Z Axis Scan

Z (mm)	0.00	4.00	9.00	14.00	19.00	24.00	29.00
SAR (W/Kg)	0.0000	2.5789	1.1300	0.8795	0.5940	0.5011	0.5100

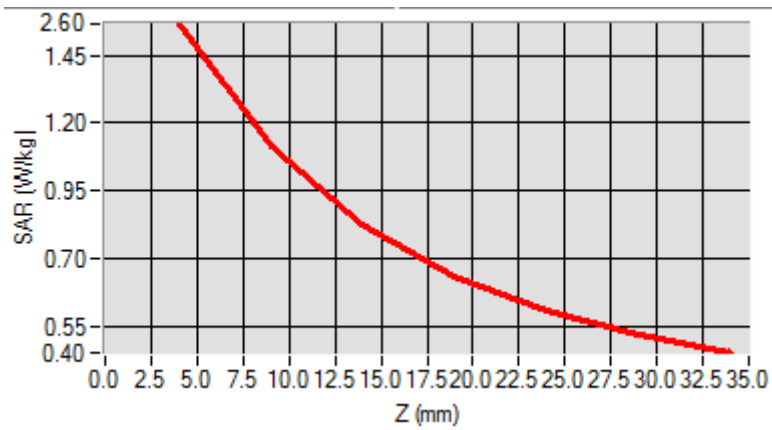

3D screen shot

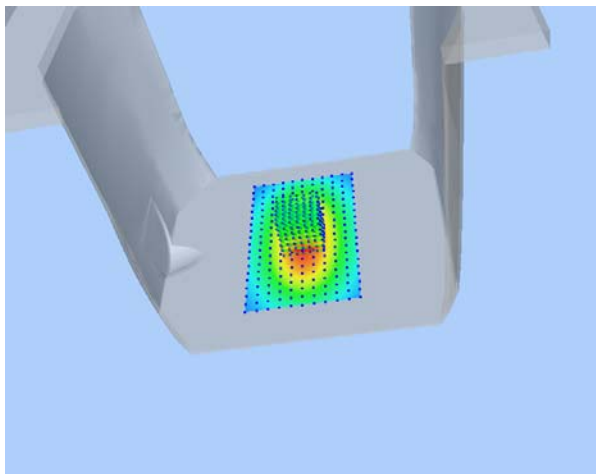

Hot spot position

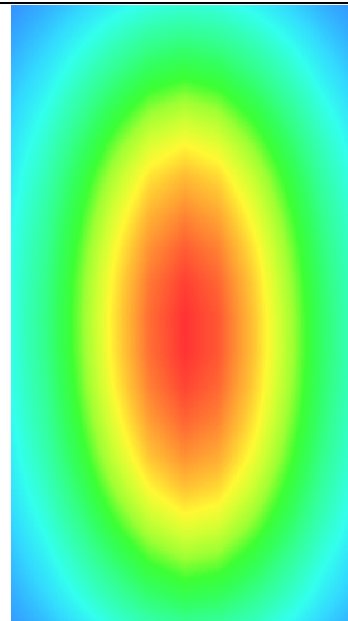

MEASUREMENT 11

For Body Liquid

Type: Validation measurement (Fast, 75.00 %)

Date of measurement: 09/17/2019

Measurement duration: 12 minutes 21 seconds

E-field Probe: SSE5 - SN 09/13 EP168; ConvF: 6.06; Calibrated: 05/22/2019

A. Experimental conditions

Area Scan	dx=8mm dy=8mm
Phantom	Validation plane
Device Position	Dipole
Band	CW1800
Signal	CW (Crest factor: 1.0)

B. SAR Measurement Results

Frequency (MHz)	1800.000000
Relative Permittivity (real part)	51.224510
Conductivity (S/m)	1.461261
Power Variation (%)	0.845690
Ambient Temperature	21.1
Liquid Temperature	21.2

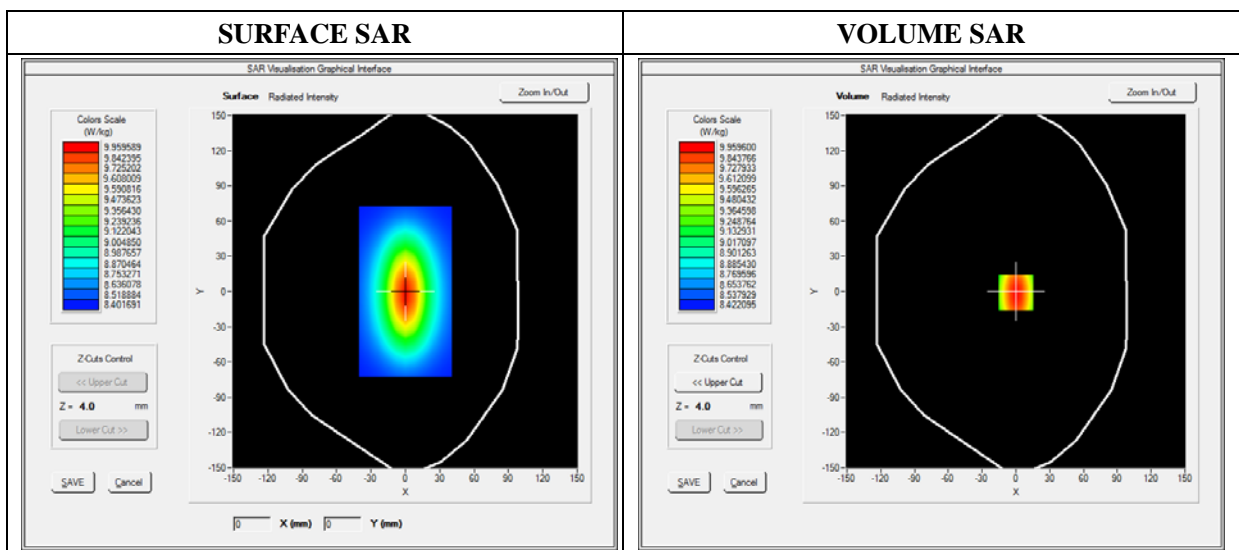

Maximum location: X=0.00, Y=0.00

SAR 10g (W/Kg)	5.221202
SAR 1g (W/Kg)	9.582560

Z Axis Scan

Z (mm)	0.00	4.00	9.00	14.00	19.00	24.00	29.00
SAR (W/Kg)	0.0000	11.2425	9.4123	8.0345	6.9125	6.3092	3.9460

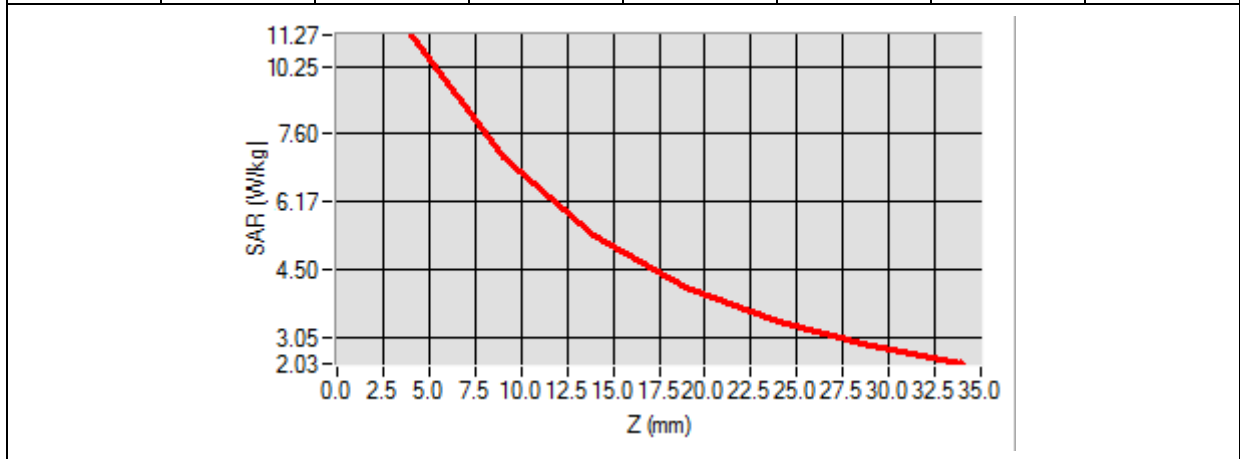

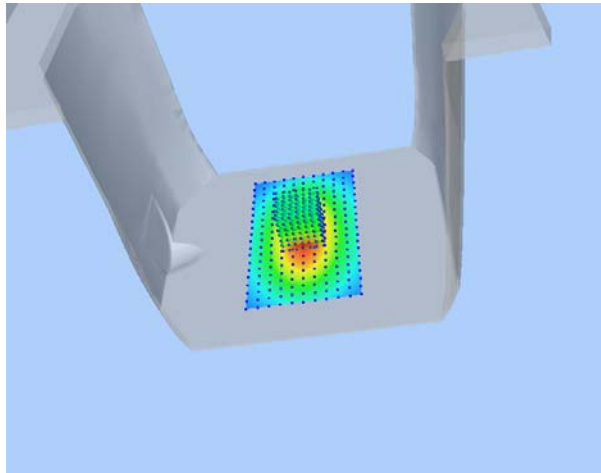
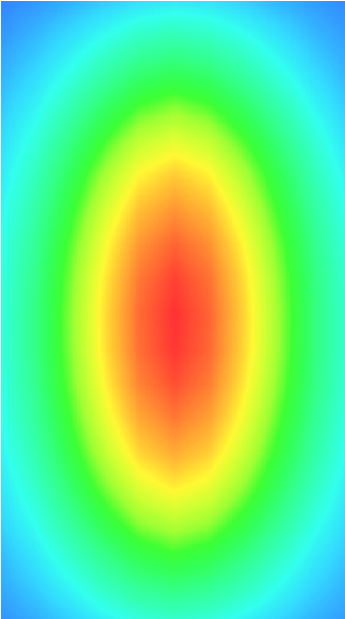
3D screen shot	Hot spot position
	

MEASUREMENT 12

For Body Liquid

Type: Validation measurement (Fast, 75.00 %)

Date of measurement: 09/17/2019

Measurement duration: 12 minutes 21 seconds

E-field Probe: SSE5 - SN 09/13 EP168; ConvF: 6.55; Calibrated: 05/22/2019

A. Experimental conditions

Area Scan	dx=8mm dy=8mm
Phantom	Validation plane
Device Position	Dipole
Band	CW1900
Signal	Duty Cycle 1:1

B. SAR Measurement Results

Frequency (MHz)	1900.000000
Relative Permittivity (real part)	52.420415
Conductivity (S/m)	1.501966
Power Variation (%)	0.541872
Ambient Temperature	21.1
Liquid Temperature	21.3

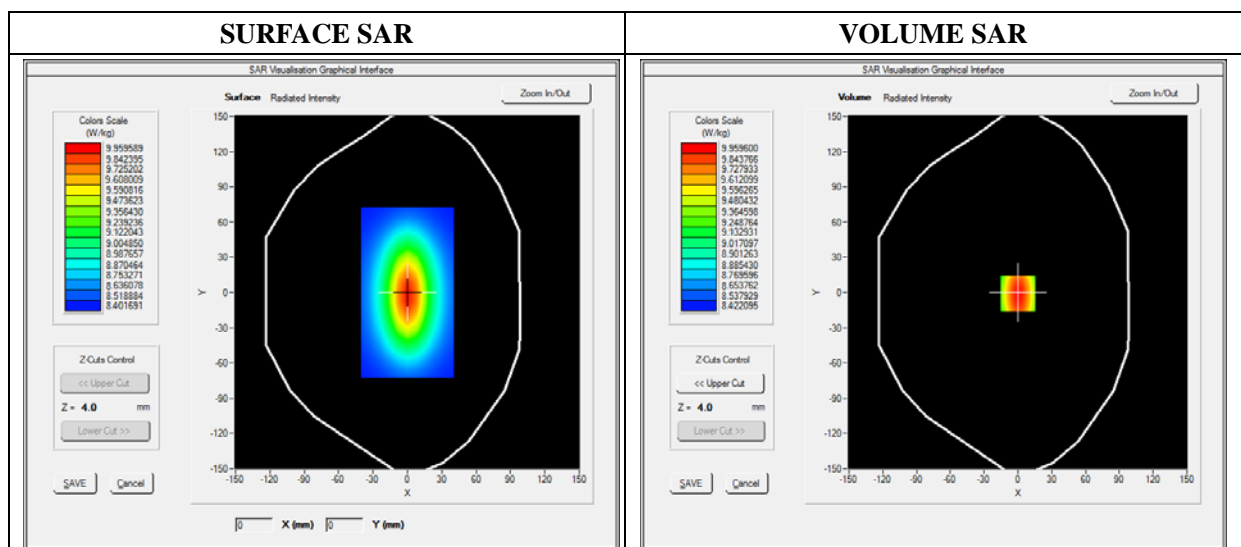

Maximum location: X=0.00, Y=0.00

SAR 10g (W/Kg)	5.134651
SAR 1g (W/Kg)	9.781550

Z Axis Scan

Z (mm)	0.00	4.00	9.00	14.00	19.00	24.00	29.00
SAR (W/Kg)	0.0000	10.2031	6.43001	4.9011	4.5325	3.1201	2.5024

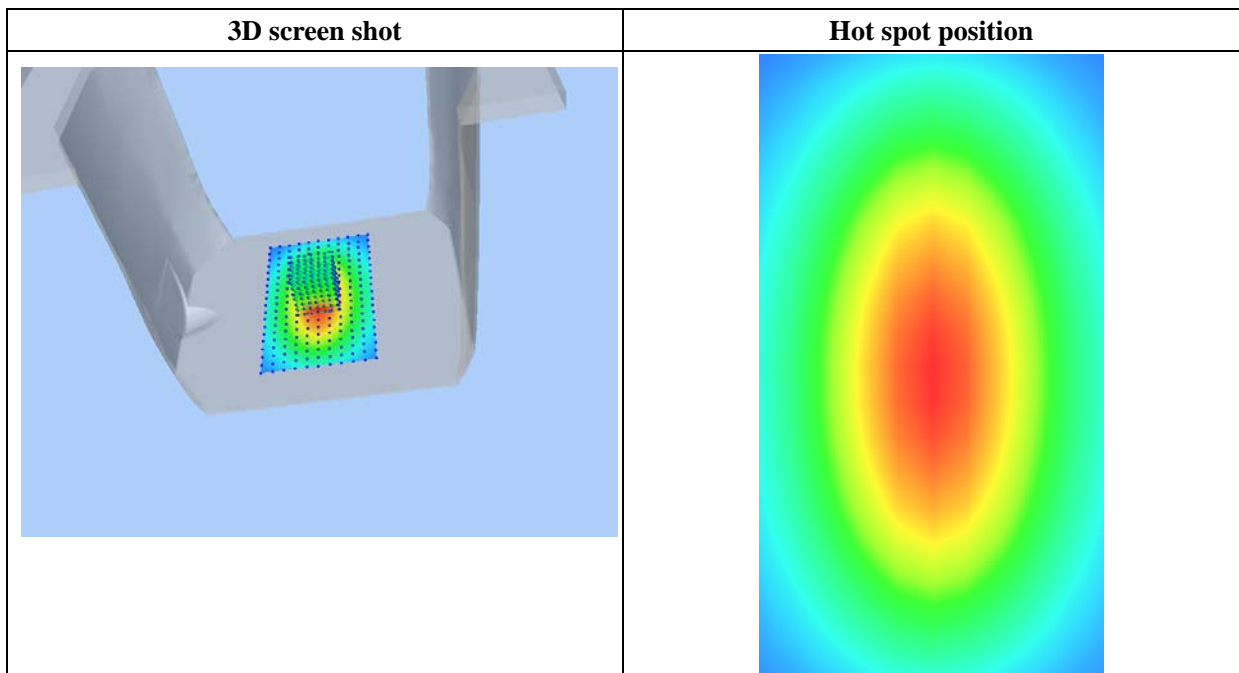
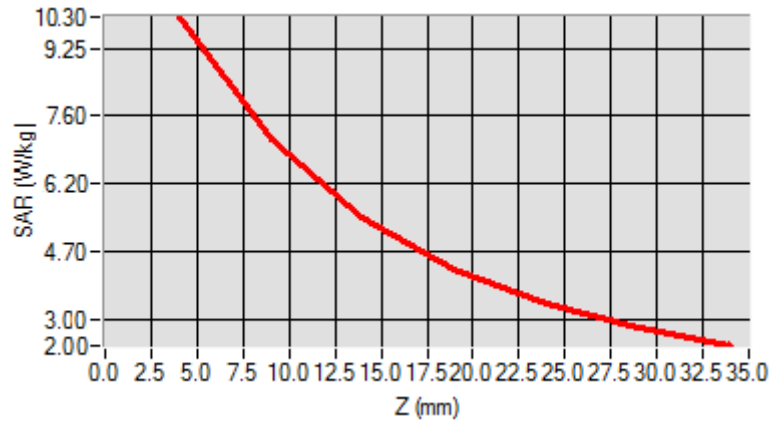

MEASUREMENT 13

For Body Liquid

Type: Validation measurement (Fast, 75.00 %)

Date of measurement: 09/18/2019

Measurement duration: 12 minutes 21 seconds

E-field Probe: SSE5 - SN 09/13 EP168; ConvF: 5.80; Calibrated: 05/22/2019

A. Experimental conditions

Area Scan	dx=8mm dy=8mm
Phantom	Validation plane
Device Position	Dipole
Band	CW2450
Signal	Duty Cycle 1:1

B. SAR Measurement Results

Frequency (MHz)	2450.000000
Relative Permittivity (real part)	52.010212
Conductivity (S/m)	1.910255
Power Variation (%)	1.369745
Ambient Temperature	21.1
Liquid Temperature	21.2

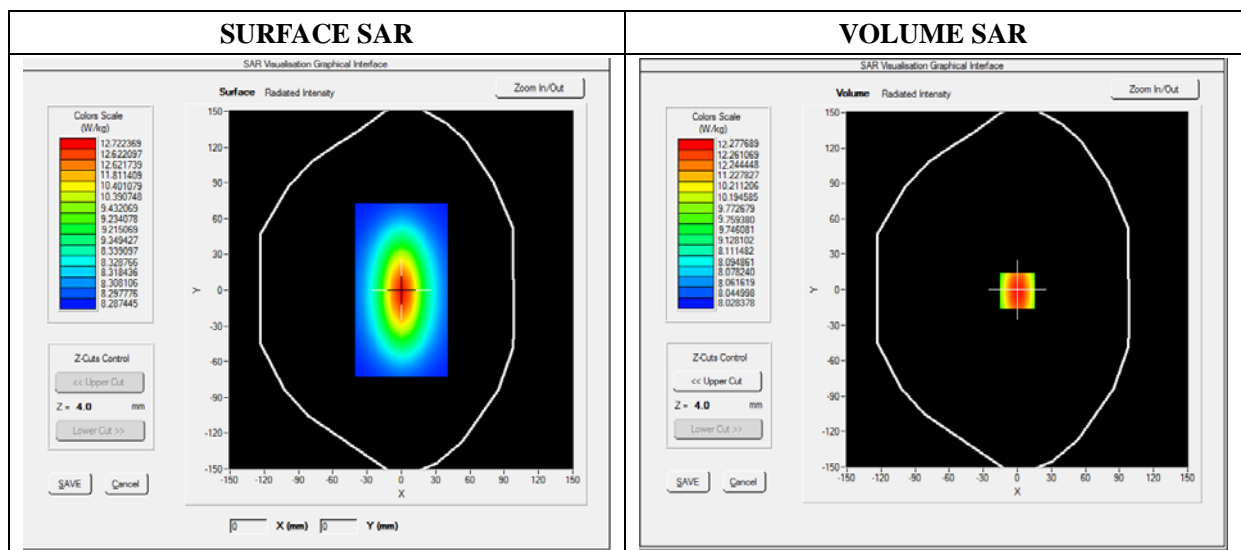

Maximum location: X=0.00, Y=0.00

SAR 10g (W/Kg)	7.119522
SAR 1g (W/Kg)	12.592360

Z Axis Scan

Z (mm)	0.00	4.00	9.00	14.00	19.00	24.00	29.00
SAR (W/Kg)	0.0000	13.1911	11.7951	9.2945	8.5400	6.3712	4.6225

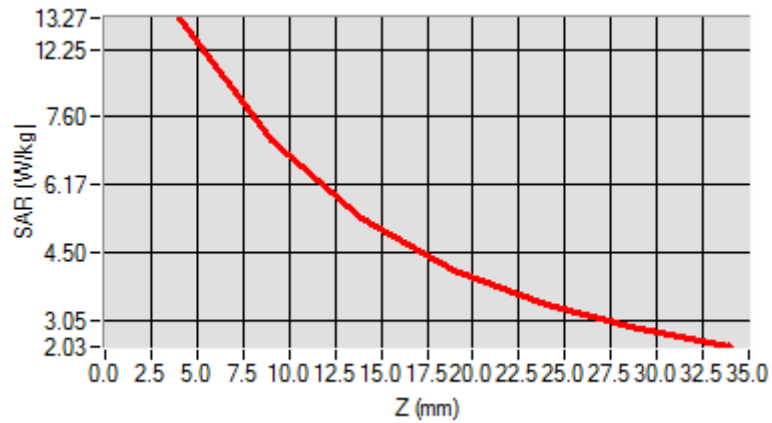

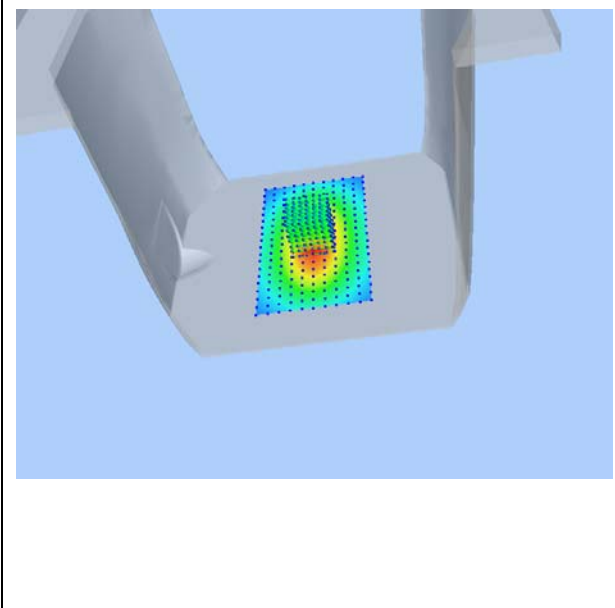
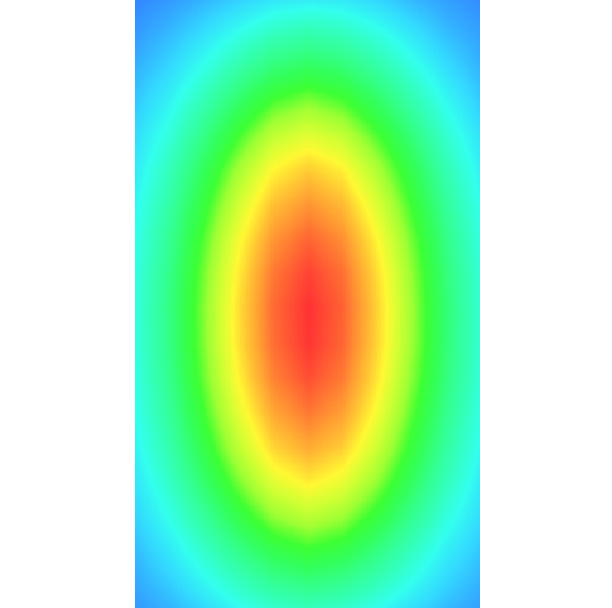
3D screen shot	Hot spot position
	

MEASUREMENT 14

For Body Liquid

Type: Validation measurement (Fast, 75.00 %)

Date of measurement: 09/18/2019

Measurement duration: 12 minutes 21 seconds

E-field Probe: SSE5 - SN 09/13 EP168; ConvF: 5.58; Calibrated: 05/22/2019

A. Experimental conditions

Area Scan	dx=8mm dy=8mm
Phantom	Validation plane
Device Position	Dipole
Band	CW2600
Signal	Duty Cycle 1:1

B. SAR Measurement Results

Frequency (MHz)	2600.000000
Relative Permittivity (real part)	52.241202
Conductivity (S/m)	2.120943
Power Variation (%)	1.038832
Ambient Temperature	21.1
Liquid Temperature	21.2

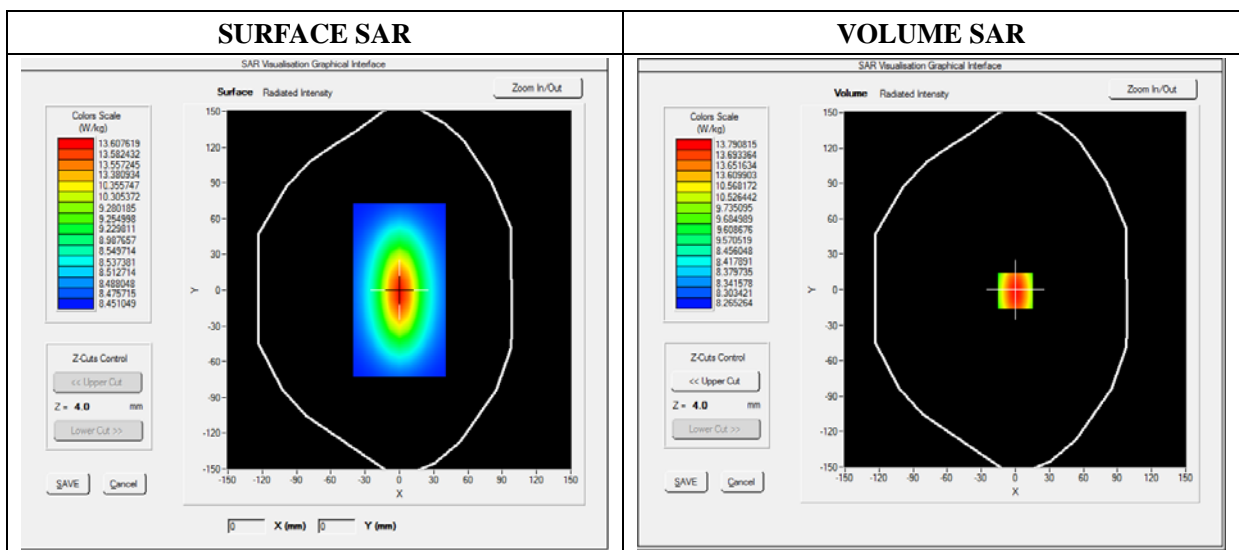

Maximum location: X=0.00, Y=0.00

SAR 10g (W/Kg)	6.083781
SAR 1g (W/Kg)	13.430481

Z Axis Scan

Z (mm)	0.00	4.00	9.00	14.00	19.00	24.00	29.00
SAR (W/Kg)	0.0000	13.6473	11.8441	9.3627	8.5782	6.4357	4.6342

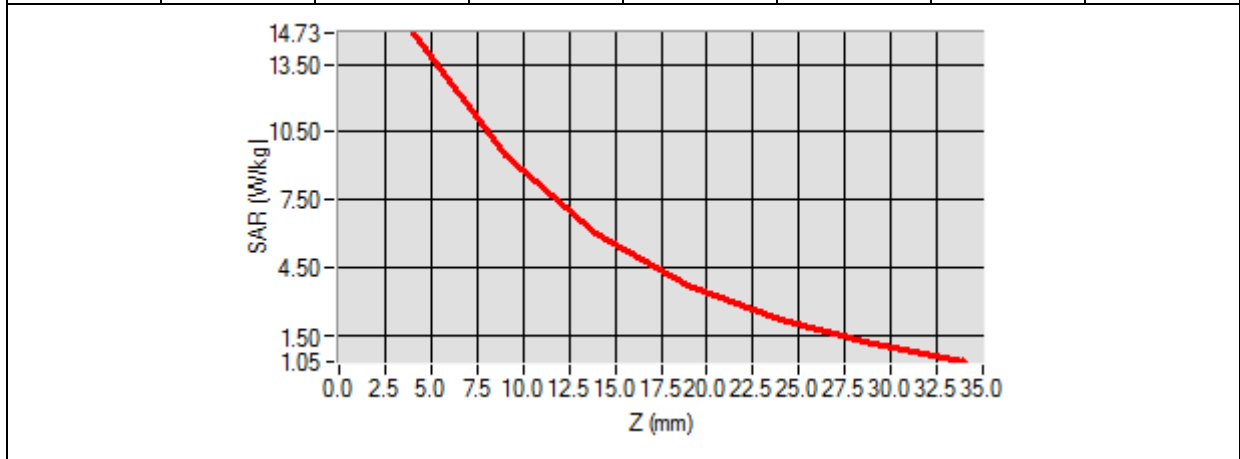

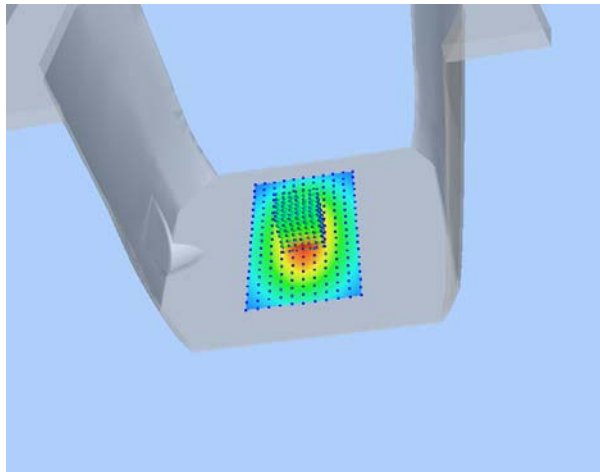
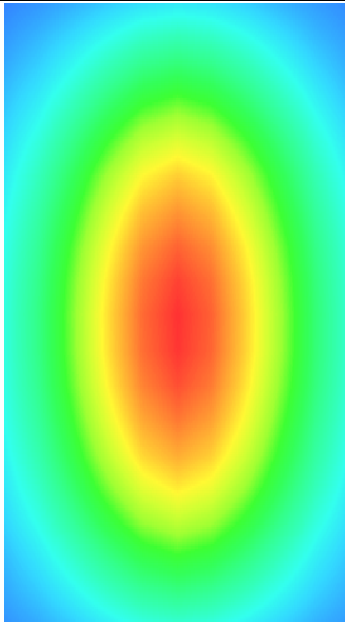
3D screen shot	Hot spot position
	

MEASUREMENT 15

For Body Liquid

Type: Validation measurement (Fast, 75.00 %)

Date of measurement: 09/19/2019

Measurement duration: 12 minutes 21 seconds

E-field Probe: SSE2 - SN 45/15 EPGO280; ConvF:2.39; Calibrated: 2019/07/08

A. Experimental conditions

Area Scan	dx=8mm dy=8mm
Phantom	Validation plane
Device Position	Dipole
Band	CW5200
Signal	Duty Cycle 1:1

B. SAR Measurement Results

Frequency (MHz)	5200.000000
Relative Permittivity (real part)	48.501241
Conductivity (S/m)	5.160213
Power Variation (%)	0.749201
Ambient Temperature	21.1
Liquid Temperature	21.2

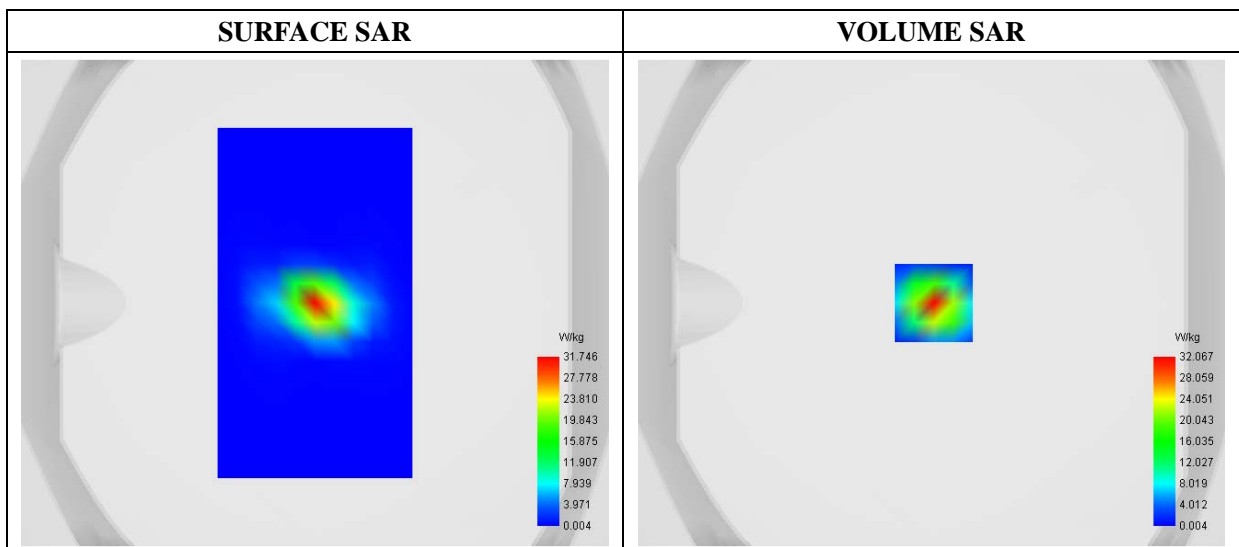

Maximum location: X=1.00, Y=0.00

SAR 10g (W/Kg)	6.047588
SAR 1g (W/Kg)	16.681175

Z (mm)	0.00	2.00	7.00	12.00	17.00	22.00	27.00
SAR (W/Kg)	49.8193	32.0669	7.0244	1.5969	0.3410	0.0635	0.0070

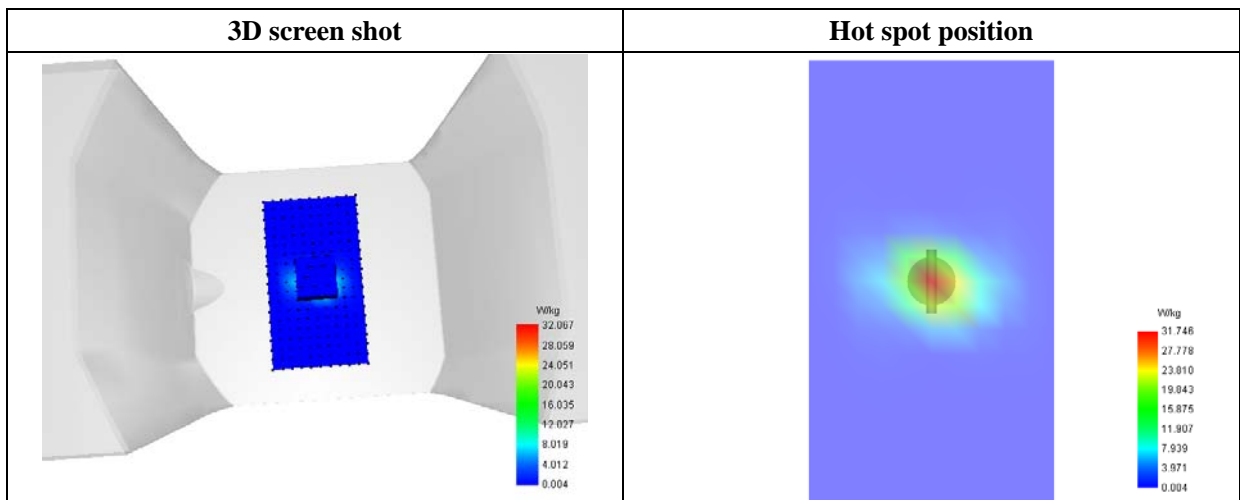
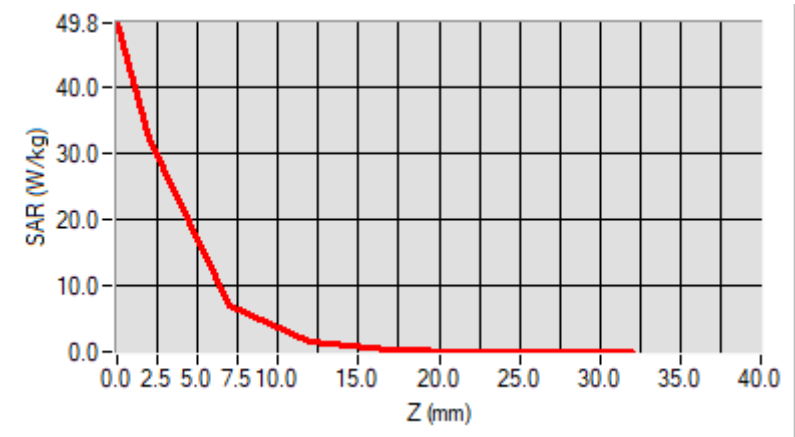

MEASUREMENT 16

For Body Liquid

Type: Validation measurement (Fast, 75.00 %)

Date of measurement: 09/19/2019

Measurement duration: 12 minutes 21 seconds

E-field Probe: SSE2 - SN 45/15 EPGO280; ConvF: 2.28; Calibrated: 2019/07/08

A. Experimental conditions

Area Scan	dx=8mm dy=8mm
Zoom Scan	dx=4mm dy=4mm dz=2mm
Phantom	Validation plane
Device Position	Dipole
Band	CW5400
Signal	CW (Crest factor: 1.0)

B. SAR Measurement Results

Frequency (MHz)	5400.000000
Relative Permittivity (real part)	48.502911
Conductivity (S/m)	5.261483
Power Variation (%)	0.943782
Ambient Temperature	21.1
Liquid Temperature	21.2

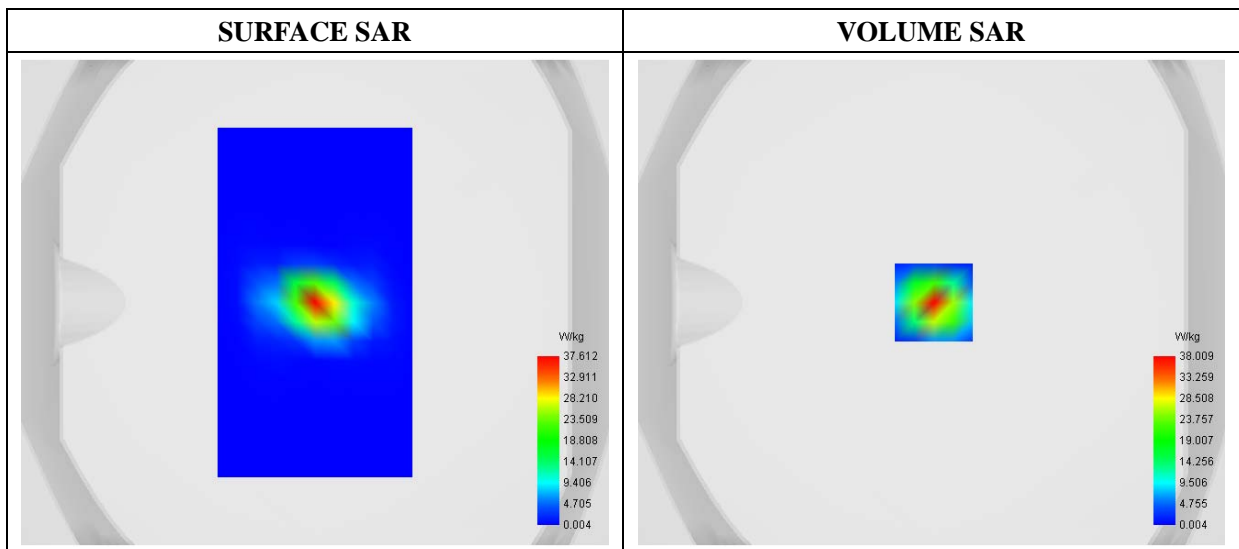

Maximum location: X=1.00, Y=0.00

SAR 10g (W/Kg)	5.872241
SAR 1g (W/Kg)	17.329716

Z (mm)	0.00	2.00	7.00	12.00	17.00	22.00	27.00
SAR (W/Kg)	59.0521	38.0093	8.3284	1.8732	0.3993	0.0816	0.0132

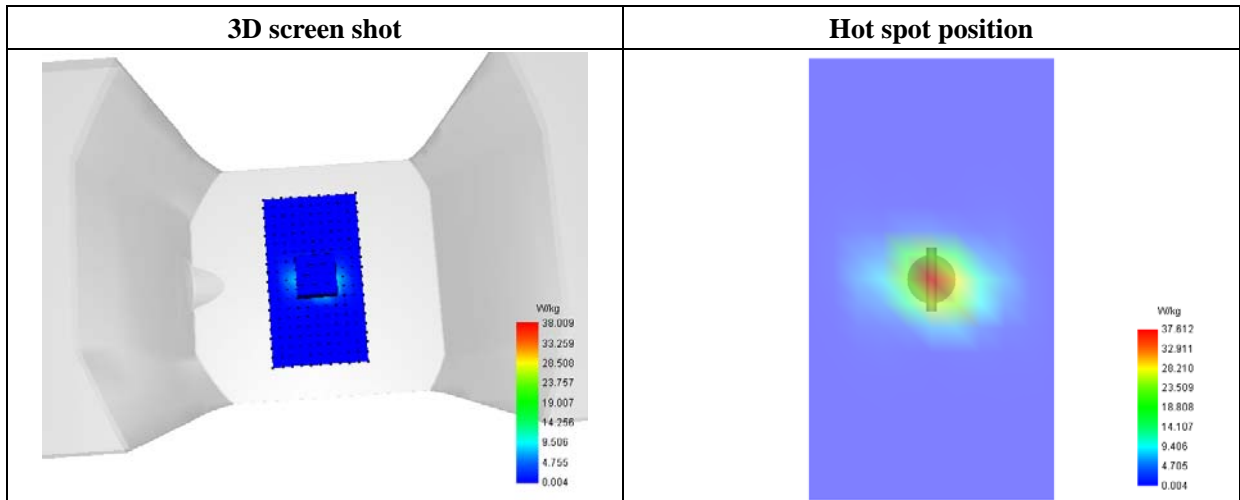
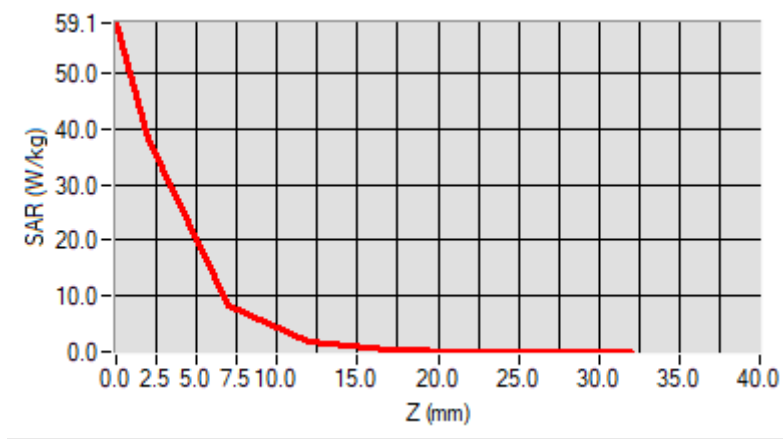

MEASUREMENT 17

For Body Liquid

Type: Validation measurement (Fast, 75.00 %)

Date of measurement: 09/19/2019

Measurement duration: 12 minutes 21 seconds

E-field Probe: SSE2 - SN 45/15 EPGO280; ConvF: 2.28; Calibrated: 2019/07/08

A. Experimental conditions

Area Scan	dx=8mm dy=8mm
Zoom Scan	dx=4mm dy=4mm dz=2mm
Phantom	Validation plane
Device Position	Dipole
Band	CW5600
Signal	Duty Cycle 1:1

B. SAR Measurement Results

Frequency (MHz)	5600.000000
Relative Permittivity (real part)	48.302143
Conductivity (S/m)	5.521688
Power Variation (%)	0.749201
Ambient Temperature	21.1
Liquid Temperature	21.2

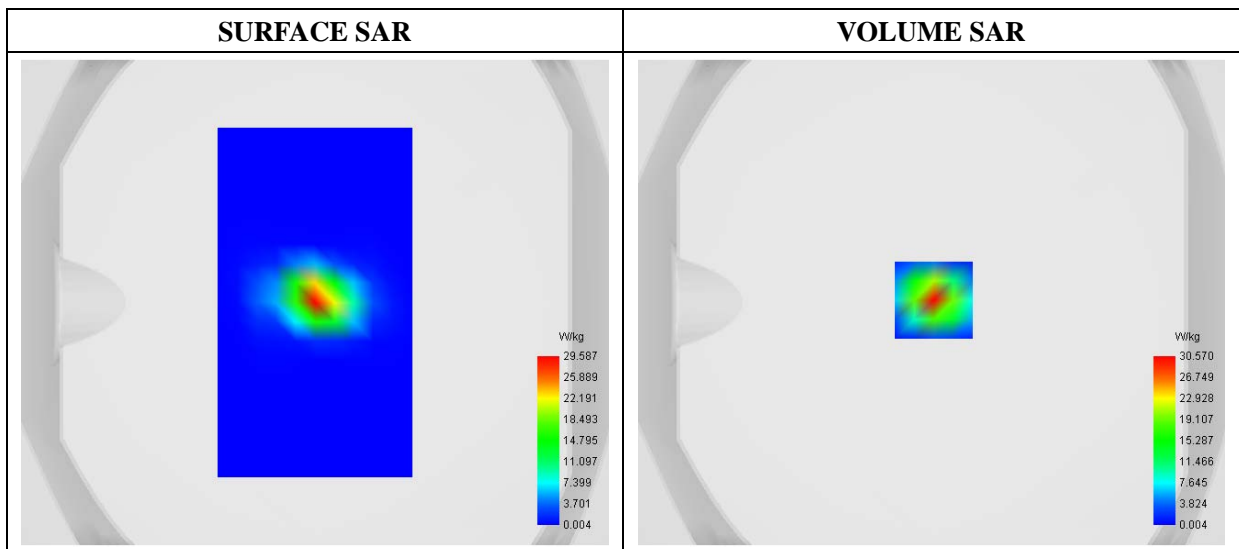

Maximum location: X=1.00, Y=1.00

SAR 10g (W/Kg)	5.912341
SAR 1g (W/Kg)	17.110732

Z (mm)	0.00	2.00	7.00	12.00	17.00	22.00	27.00
SAR (W/Kg)	48.4695	30.5699	5.7100	1.0698	0.1906	0.0364	0.0052

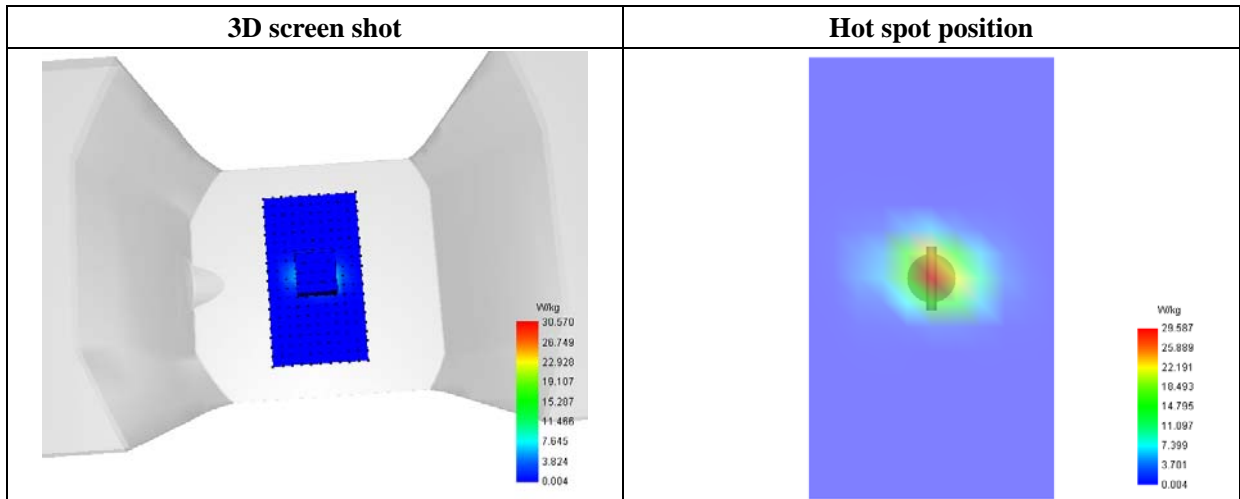
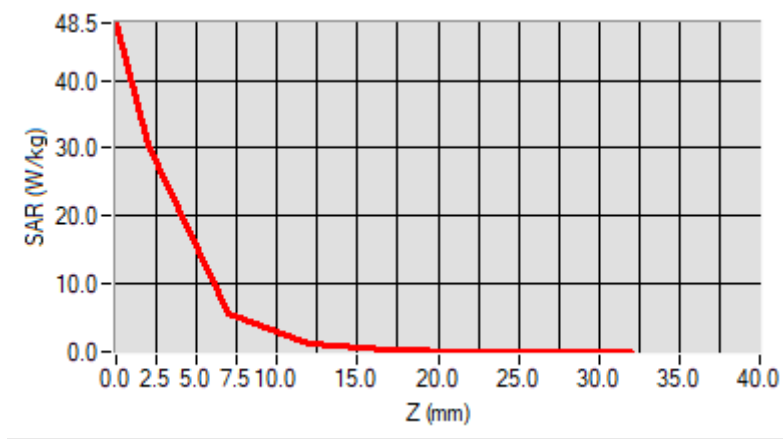

MEASUREMENT 18

For Body Liquid

Type: Validation measurement (Fast, 75.00 %)

Date of measurement: 2019/09/19

Measurement duration: 12 minutes 21 seconds

E-field Probe: SSE2 - SN 45/15 EPGO280; ConvF:2.50; Calibrated: 2017/09/18

A. Experimental conditions

Area Scan	dx=8mm dy=8mm
Phantom	Validation plane
Device Position	Dipole
Band	CW5800
Signal	Duty Cycle 1:1

B. SAR Measurement Results

Frequency (MHz)	5800.000000
Relative Permittivity (real part)	48.501939
Conductivity (S/m)	5.761487
Power Variation (%)	0.749201
Ambient Temperature	21.1
Liquid Temperature	21.2

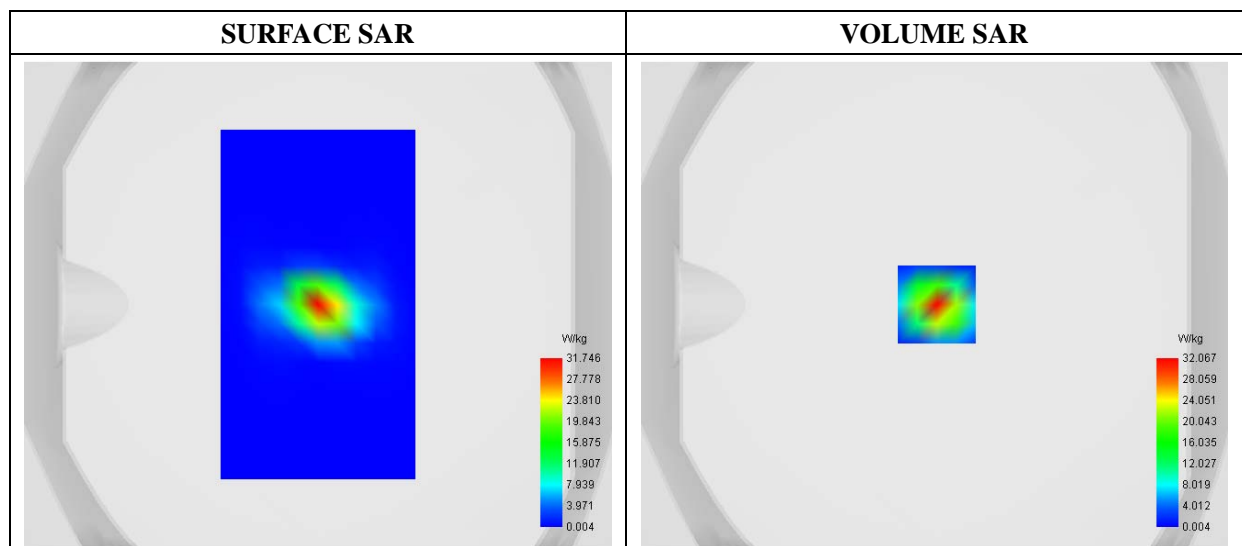

Maximum location: X=1.00, Y=0.00

SAR 10g (W/Kg)	6.047588
SAR 1g (W/Kg)	16.681175

Z (mm)	0.00	2.00	7.00	12.00	17.00	22.00	27.00
SAR (W/Kg)	49.8193	32.0669	7.0244	1.5969	0.3410	0.0635	0.0070

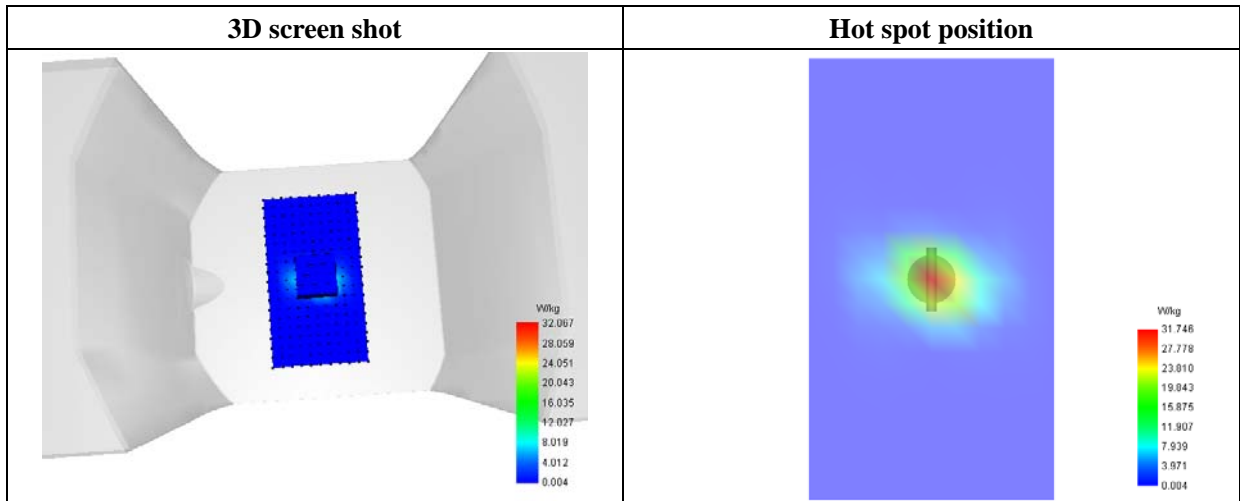
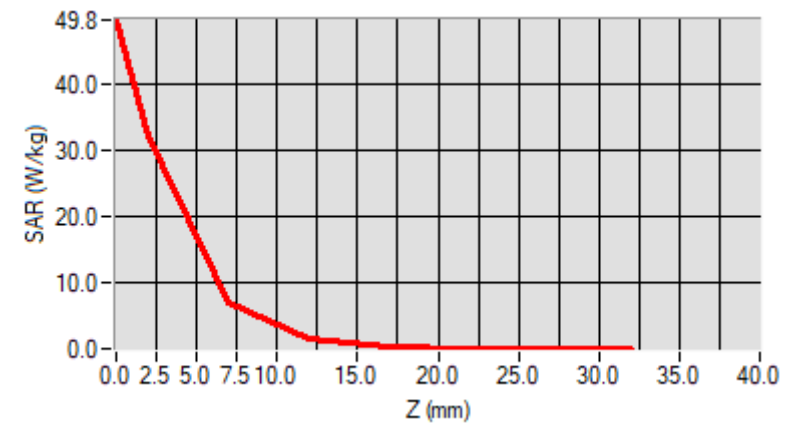

Annex B. Plots of SAR Measurement

<u>TYPE</u>	<u>BAND</u>	<u>PARAMETERS</u>
Phone	GSM850	<u>Measurement 3:</u> Left Head with Cheek device position on Low Channel in GSM mode
Phone	GSM1900	<u>Measurement 5:</u> Right Head with Cheek device position on High Channel in GSM mode
Phone	GPRS850_4TX	<u>Measurement 13:</u> Left Head with Cheek device position on Low Channel in GPRS mode
Phone	GPRS1900_2TX	<u>Measurement 17:</u> Right Head with Cheek device position on High Channel in GPRS mode
Phone	WCDMA1900_RMC	<u>Measurement 21:</u> Right Head with Cheek device position on High Channel in WCDMA mode
Phone	WCDMA850_RMC	<u>Measurement 27:</u> Left Head with Cheek device position on Middle Channel in WCDMA mode
Phone	WCDMA1700_RMC	<u>Measurement 29:</u> Right Head with Cheek device position on High Channel in WCDMA mode
Phone	LTE Band 2_RMC	<u>Measurement 33:</u> Right Head with Cheek device position on Low Channel in LTE mode
Phone	LTE Band 4_RMC	<u>Measurement 41:</u> Right Head with Cheek device position on Low Channel in LTE mode
Phone	LTE Band 5_RMC	<u>Measurement 49:</u> Right Head with Cheek device position on Low Channel in LTE mode
Phone	LTE Band 7_RMC	<u>Measurement 57:</u> Right Head with Cheek device position on High Channel in LTE mode
Phone	LTE Band 12_RMC	<u>Measurement 67:</u> Left Head with Cheek device position on Middle Channel in LTE mode
Phone	LTE Band 13_RMC	<u>Measurement 75:</u> Left Head with Cheek device position on Middle Channel in LTE mode
Phone	LTE Band 17_RMC	<u>Measurement 83:</u> Left Head with Cheek device position on High Channel in LTE mode
Phone	LTE Band 25_RMC	<u>Measurement 89:</u> Right Head with Cheek device position on Low Channel in LTE mode
Phone	LTE Band 26_RMC	<u>Measurement 99:</u> Left Head with Cheek device position on Middle Channel in LTE mode
Phone	LTE Band 30_RMC	<u>Measurement 105:</u> Right Head with Cheek device position on Low Channel in LTE mode
Phone	LTE Band 40_RMC 2305-2315MHz	<u>Measurement 113:</u> Right Head with Cheek device position on Middle Channel in LTE mode
Phone	LTE Band 40_RMC 2350-2360MHz	<u>Measurement 121:</u> Right Head with Cheek device position on Middle Channel in LTE mode
Phone	LTE Band 66_RMC	<u>Measurement 129:</u> Right Head with Cheek device

		position on Low Channel in LTE mode
Phone	WiFi_802.11b	<u>Measurement 137:</u> Right Head with Cheek device position on High Channel in 802.11b mode
Phone	WLAN 5.2GHz_802.11a	<u>Measurement 141:</u> Right Head with Cheek device position on High Channel in 802.11a mode
Phone	WLAN 5.3GHz_802.11n-40	<u>Measurement 147:</u> Left Head with Cheek device position on Low Channel in 802.11n mode
Phone	WLAN 5.6GHz_802.11a	<u>Measurement 151:</u> Left Head with Cheek device position on Low Channel in 802.11a mode
Phone	WLAN 5.8GHz_802.11a	<u>Measurement 153:</u> Right Head with Cheek device position on High Channel in 802.11a mode
Phone	GSM850	<u>Measurement 157:</u> Flat Plane with Back(Body-worn) device position on Low Channel in GSM mode
Phone	GSM1900	<u>Measurement 159:</u> Flat Plane with Back(Body-worn) device position on High Channel in GSM mode
Phone	GPRS850_4TX	<u>Measurement 235:</u> Flat Plane with Back device position on Low Channel in GPRS mode
Phone	GPRS1900_2TX	<u>Measurement 245:</u> Flat Plane with Back device position on Low Channel in GPRS mode
Phone	WCDMA1900_RMC	<u>Measurement 257:</u> Flat Plane with Back side device position on Middle Channel in WCDMA mode
Phone	WCDMA850_RMC	<u>Measurement 262:</u> Flat Plane with Back side device position on Middle Channel in WCDMA mode
Phone	WCDMA1700_RMC	<u>Measurement 267:</u> Flat Plane with Back side device position on High Channel in WCDMA mode
Phone	LTE Band 2_RMC	<u>Measurement 281:</u> Flat Plane with Bottom device position on Middle Channel in LTE mode
Phone	LTE Band 4_RMC	<u>Measurement 293:</u> Flat Plane with Bottom device position on Low Channel in LTE mode
Phone	LTE Band 5_RMC	<u>Measurement 299:</u> Flat Plane with Back device position on Low Channel in LTE mode
Phone	LTE Band 7_RMC	<u>Measurement 311:</u> Flat Plane with Back device position on Middle Channel in LTE mode
Phone	LTE Band 12_RMC	<u>Measurement 322:</u> Flat Plane with Back device position on Middle Channel in LTE mode
Phone	LTE Band 13_RMC	<u>Measurement 332:</u> Flat Plane with Back device position on Middle Channel in LTE mode
Phone	LTE Band 17_RMC	<u>Measurement 342:</u> Flat Plane with Back device position on High Channel in LTE mode
Phone	LTE Band 25_RMC	<u>Measurement 358:</u> Flat Plane with Bottom device position on High Channel in LTE mode
Phone	LTE Band 26_RMC	<u>Measurement 365:</u> Flat Plane with Back device position on Middle Channel in LTE mode

Phone	LTE Band 30_RMC	<u>Measurement 375: Flat Plane with Back device position on Low Channel in LTE mode</u>
Phone	LTE Band 40_RMC 2305-2315MHz	<u>Measurement 385: Flat Plane with Back device position on Middle Channel in LTE mode</u>
Phone	LTE Band 40_RMC 2350-2360MHz	<u>Measurement 395: Flat Plane with Back device position on Middle Channel in LTE mode</u>
Phone	LTE Band 66_RMC	<u>Measurement 411: Flat Plane with Bottom device position on High Channel in LTE mode</u>
Phone	WiFi_802.11b	<u>Measurement 418: Flat Plane with Back side device position on High Channel in 802.11b mode</u>
Phone	WLAN 5.2GHz _802.11a	<u>Measurement 424: Flat Plane with Back side device position on High Channel in 802.11a mode</u>
Phone	WLAN 5.3GHz _802.11n-40	<u>Measurement 426: Flat Plane with Back side device position on Low Channel in 802.11n-20 mode</u>
Phone	WLAN 5.6GHz _802.11a	<u>Measurement 430: Flat Plane with Back side device position on Low Channel in 802.11a0 mode</u>
Phone	WLAN 5.8GHz _802.11a	<u>Measurement 436: Flat Plane with Back side device position on High Channel in 802.11a mode</u>
<i>Remark: SAR plot is showed the highest measured SAR in each exposure configuration, wireless mode and frequency band combination.</i>		

Extremity SAR

<u>TYPE</u>	<u>BAND</u>	<u>PARAMETERS</u>
Phone	GPRS850_4TX	<u>Measurement 438: Flat Plane with Back device position on Low Channel in GPRS mode</u>
Phone	GPRS1900_2TX	<u>Measurement 439: Flat Plane with Back device position on Low Channel in GPRS mode</u>
<i>Remark: SAR plot is showed the highest measured SAR in each exposure configuration, wireless mode and frequency band combination.</i>		

<u>TYPE</u>	<u>BAND</u>	<u>PARAMETERS</u>
Phone	GPRS850_4TX	<u>Measurement 442: Flat Plane with Front device position on Low Channel in PTT mode</u>
Phone	GPRS1900_2TX	<u>Measurement 443: Flat Plane with Front device position on High Channel in PTT mode</u>

MEASUREMENT 3

Type: Phone measurement (Complete)

Date of measurement: 09/16/2019

Measurement duration: 11 minutes 48 seconds

E-field Probe: SSE5 - SN 09/13 EP168; ConvF: 6.93; Calibrated: 05/22/2019

A. Experimental conditions

Area Scan	sam_direct_droit2_surf8mm.txt
Phantom	Left head
Device Position	Cheek
Band	GSM850
Channels	Low
Signal	TDMA (Crest factor: 8.0)

B. SAR Measurement Results

Frequency (MHz)	824.200000
Relative Permittivity (real part)	41.110245
Conductivity (S/m)	0.871245
Power Variation (%)	1.144536
Ambient Temperature	21.1
Liquid Temperature	21.3

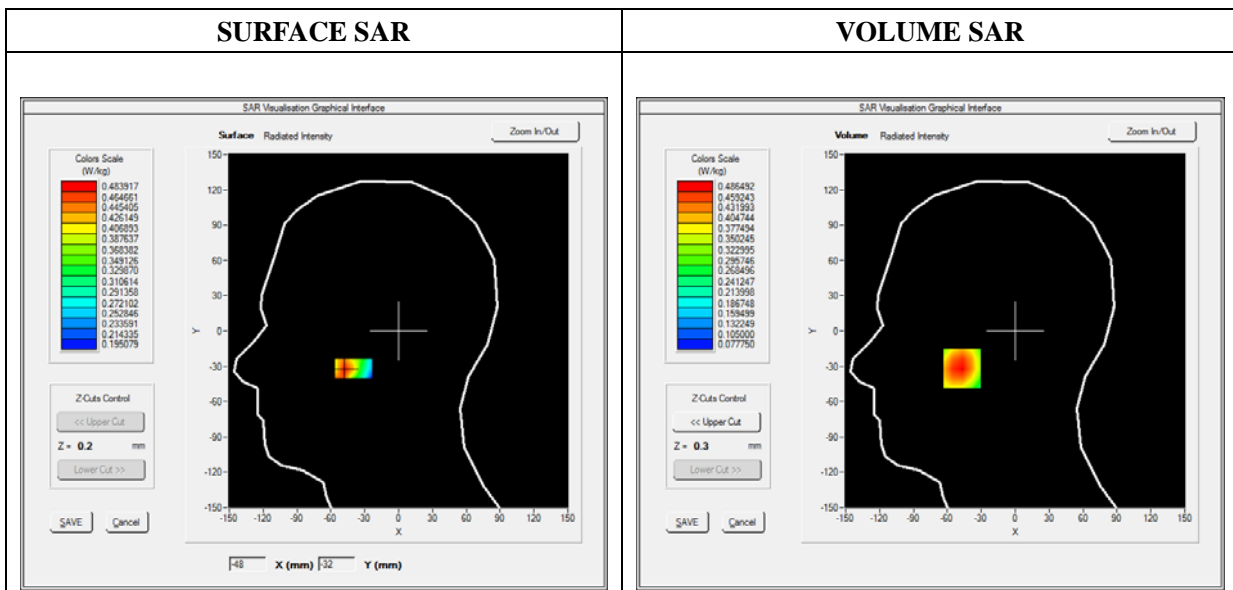



Maximum location: X=-47.00, Y=-32.00

SAR Peak: 0.56 W/kg

SAR 10g (W/Kg)	0.361003
SAR 1g (W/Kg)	0.473834

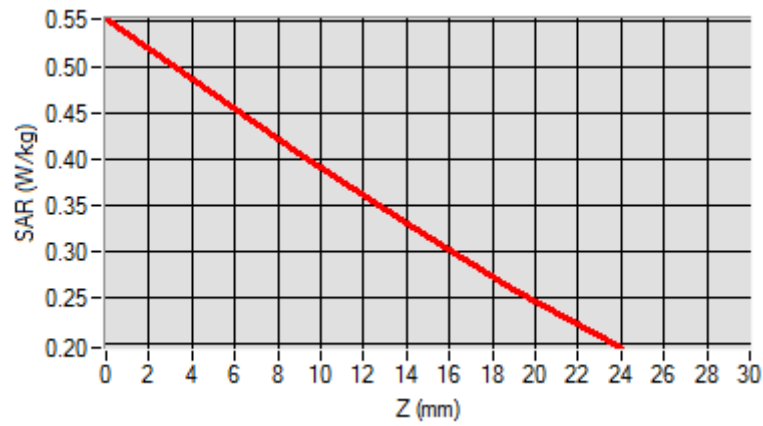
Z (mm)	0.00	4.00	9.00	14.00	19.00
SAR (W/Kg)	0.5525	0.4865	0.4064	0.3300	0.2588

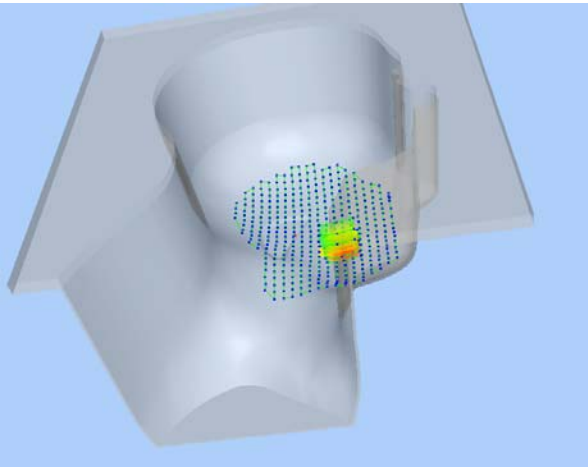

3D screen shot	Hot spot position
	

MEASUREMENT 5

Type: Phone measurement (Complete)

Date of measurement: 09/17/2019

Measurement duration: 11 minutes 48 seconds

E-field Probe: SSE5 - SN 09/13 EP168; ConvF: 6.35; Calibrated: 05/22/2019

A. Experimental conditions

Area Scan	sam_direct_droit2_surf8mm.txt
Phantom	Right head
Device Position	Cheek
Band	GSM1900
Channels	High
Signal	TDMA (Crest factor: 8.0)

B. SAR Measurement Results

Frequency (MHz)	1909.800000
Relative Permittivity (real part)	38.560124
Conductivity (S/m)	1.380369
Power Variation (%)	1.442440
Ambient Temperature	21.1
Liquid Temperature	21.3

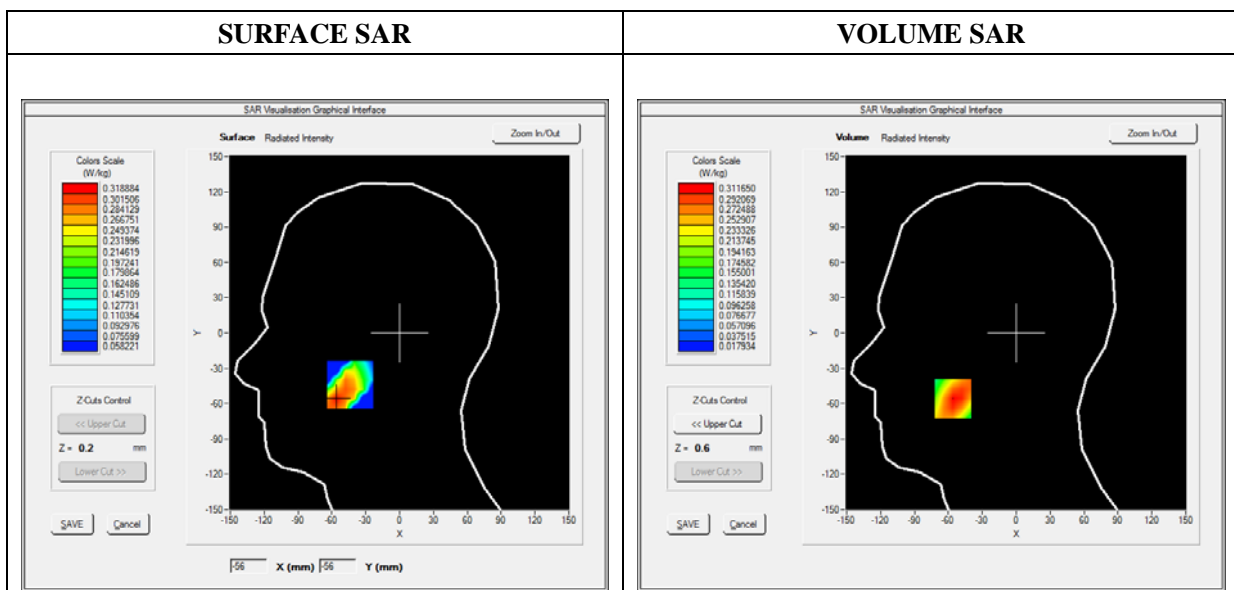

Maximum location: X=-56.00, Y=-56.00

SAR Peak: 0.51 W/kg

SAR 10g (W/Kg)	0.174267
SAR 1g (W/Kg)	0.299845

Z (mm)	0.00	4.00	9.00	14.00	19.00
SAR (W/Kg)	0.5047	0.3116	0.1675	0.0940	0.0594

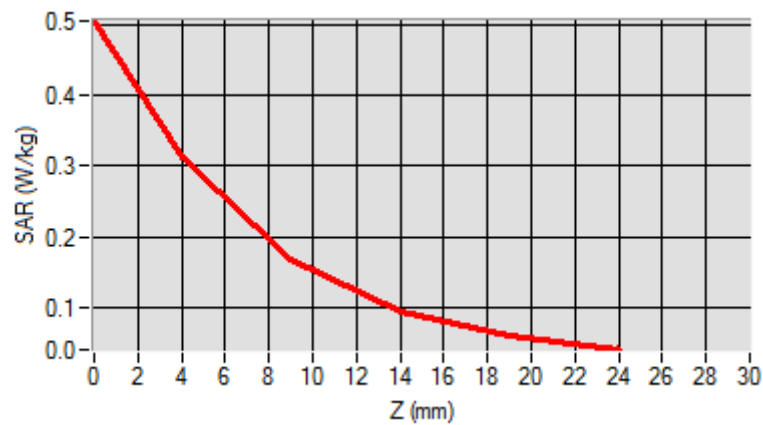

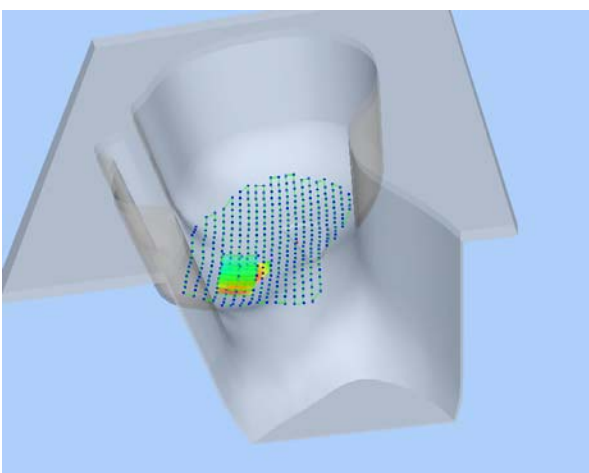
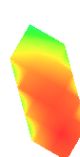
3D screen shot	Hot spot position
	

MEASUREMENT 13

Type: Phone measurement (Complete)

Date of measurement: 09/16/2019

Measurement duration: 12 minutes 3 seconds

E-field Probe: SSE5 - SN 09/13 EP168; ConvF: 6.93; Calibrated: 05/22/2019

A. Experimental conditions

Area Scan	sam_direct_droit2_surf8mm.txt
Phantom	Left head
Device Position	Cheek
Band	GPRS850_4TX
Channels	Low
Signal	Duty Cycle: 1:2

B. SAR Measurement Results

Frequency (MHz)	824.200000
Relative Permittivity (real part)	41.110245
Conductivity (S/m)	0.871245
Power Variation (%)	1.536272
Ambient Temperature	21.1
Liquid Temperature	21.3

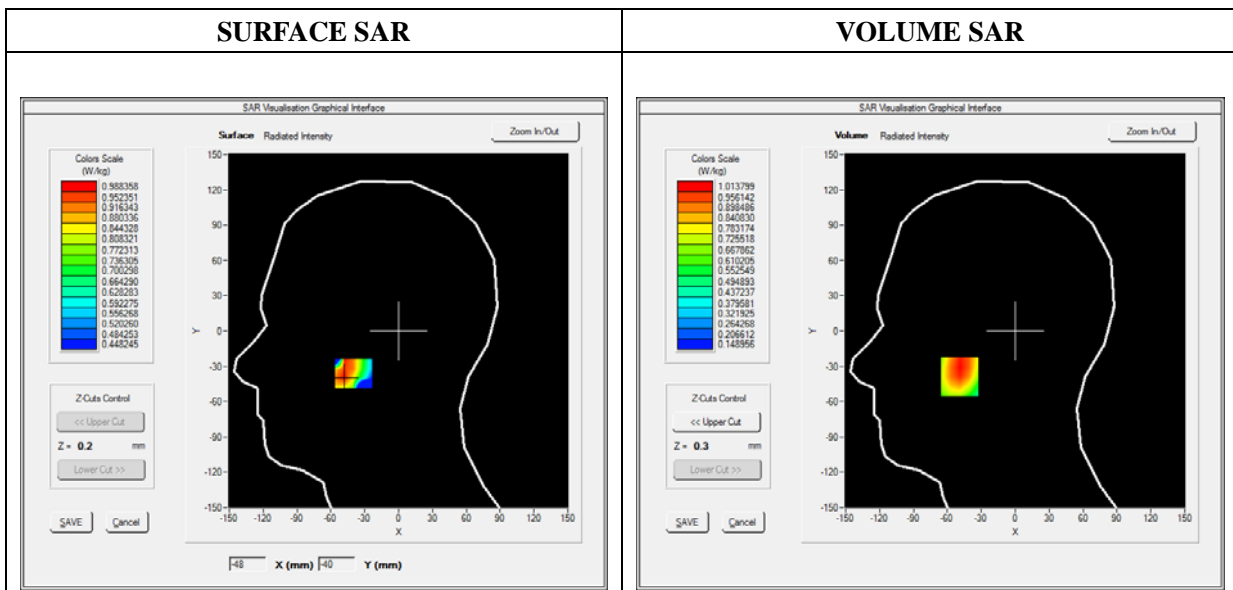



Maximum location: X=-49.00, Y=-39.00

SAR Peak: 1.22 W/kg

SAR 10g (W/Kg)	0.733252
SAR 1g (W/Kg)	0.976362

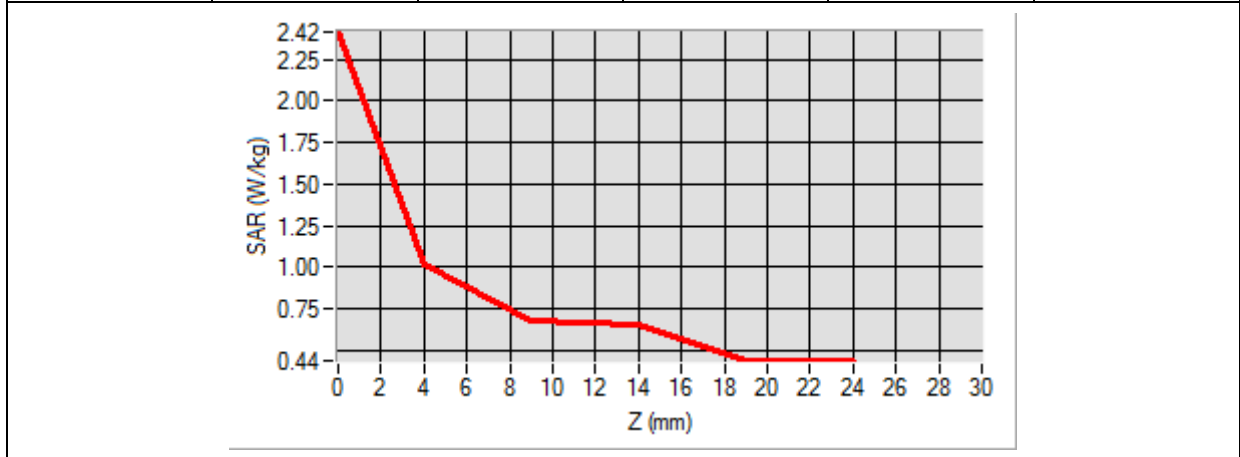
Z (mm)	0.00	4.00	9.00	14.00	19.00
SAR (W/Kg)	2.4165	1.0138	0.6796	0.6539	0.4375

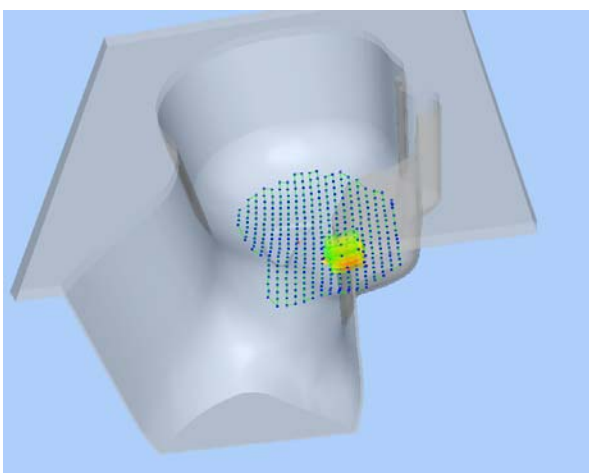

3D screen shot	Hot spot position
	

MEASUREMENT 17

Type: Phone measurement (Complete)

Date of measurement: 09/17/2019

Measurement duration: 12 minutes 3 seconds

E-field Probe: SSE5 - SN 09/13 EP168; ConvF: 6.35; Calibrated: 05/22/2019

A. Experimental conditions

Area Scan	sam_direct_droit2_surf8mm.txt
Phantom	Right head
Device Position	Cheek
Band	GPRS1900_2TX
Channels	High
Signal	Duty Cycle: 1:4

B. SAR Measurement Results

Frequency (MHz)	1909.800000
Relative Permittivity (real part)	38.560124
Conductivity (S/m)	1.380369
Power Variation (%)	1.536272
Ambient Temperature	21.1
Liquid Temperature	21.3

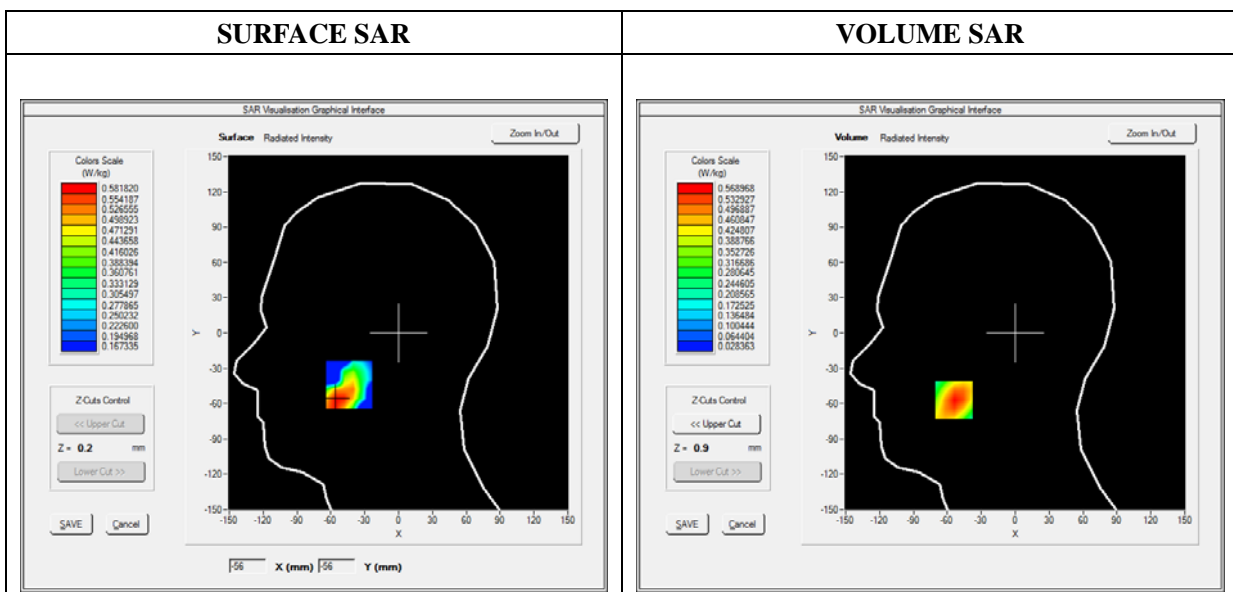

Maximum location: X=-54.00, Y=-57.00

SAR Peak: 0.91 W/kg

SAR 10g (W/Kg)	0.306258
SAR 1g (W/Kg)	0.539999

Z (mm)	0.00	4.00	9.00	14.00	19.00
SAR (W/Kg)	0.9009	0.5690	0.3141	0.1783	0.1099

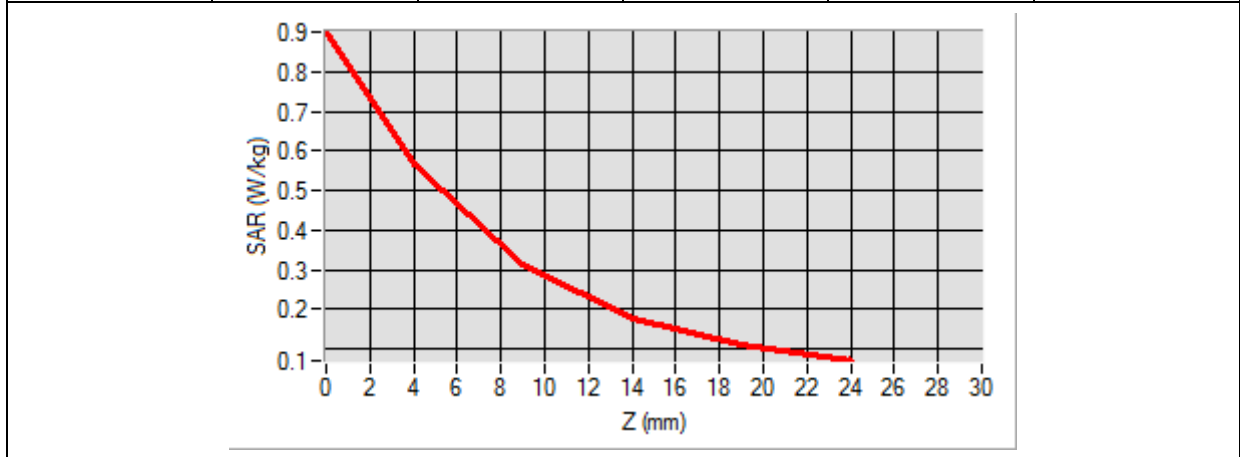

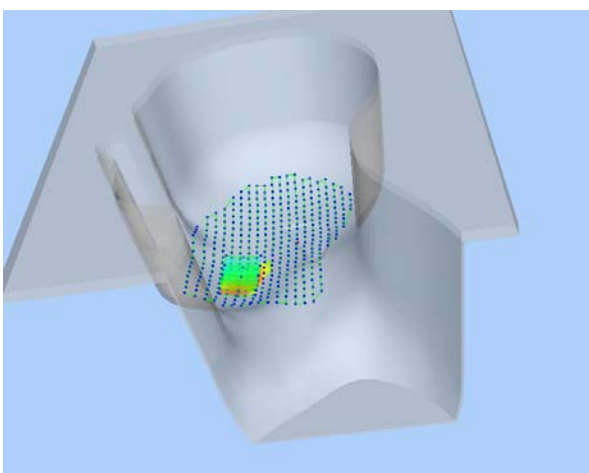
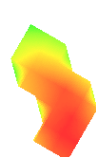
3D screen shot	Hot spot position
	

MEASUREMENT 21

Type: Phone measurement (Complete)

Date of measurement: 09/17/2019

Measurement duration: 12 minutes 3 seconds

E-field Probe: SSE5 - SN 09/13 EP168; ConvF: 6.35; Calibrated: 05/22/2019

A. Experimental conditions

Area Scan	sam_direct_droit2_surf8mm.txt
Phantom	Right head
Device Position	Cheek
Band	WCDMA1900_RMC
Channels	High
Signal	Duty Cycle 1:1

B. SAR Measurement Results

Frequency (MHz)	1907.600000
Relative Permittivity (real part)	38.560124
Conductivity (S/m)	1.380369
Power Variation (%)	1.524540
Ambient Temperature	21.1
Liquid Temperature	21.3

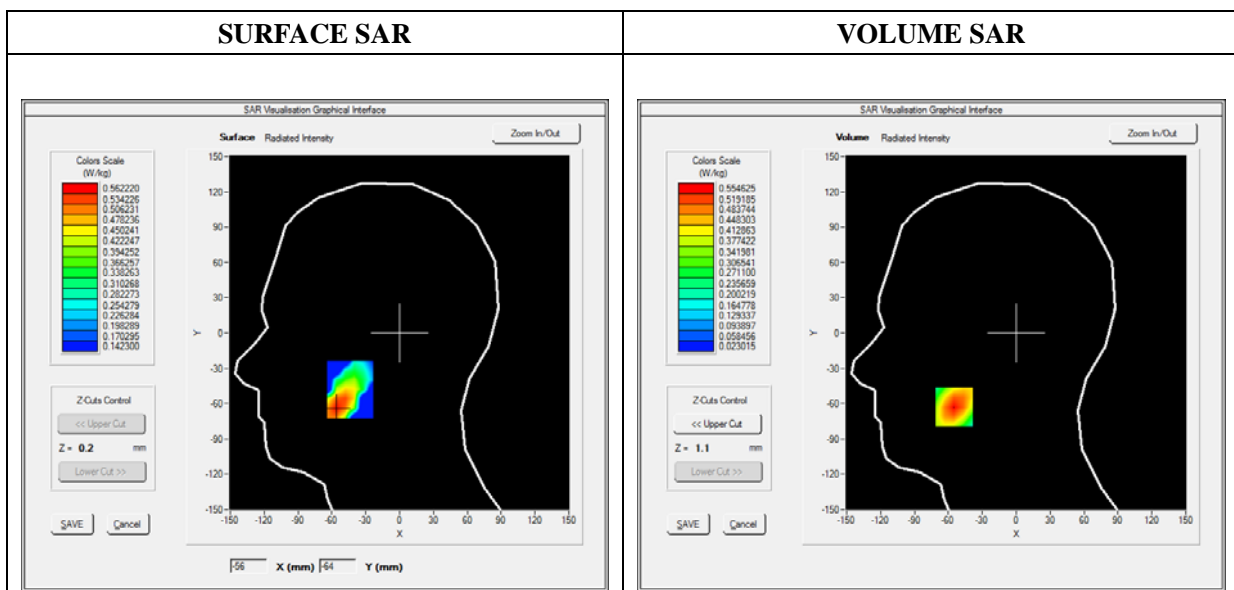

Maximum location: X=-55.00, Y=-63.00

SAR Peak: 0.90 W/kg

SAR 10g (W/Kg)	0.292856
SAR 1g (W/Kg)	0.524257

Z (mm)	0.00	4.00	9.00	14.00	19.00
SAR (W/Kg)	0.8976	0.5546	0.2971	0.1646	0.1010

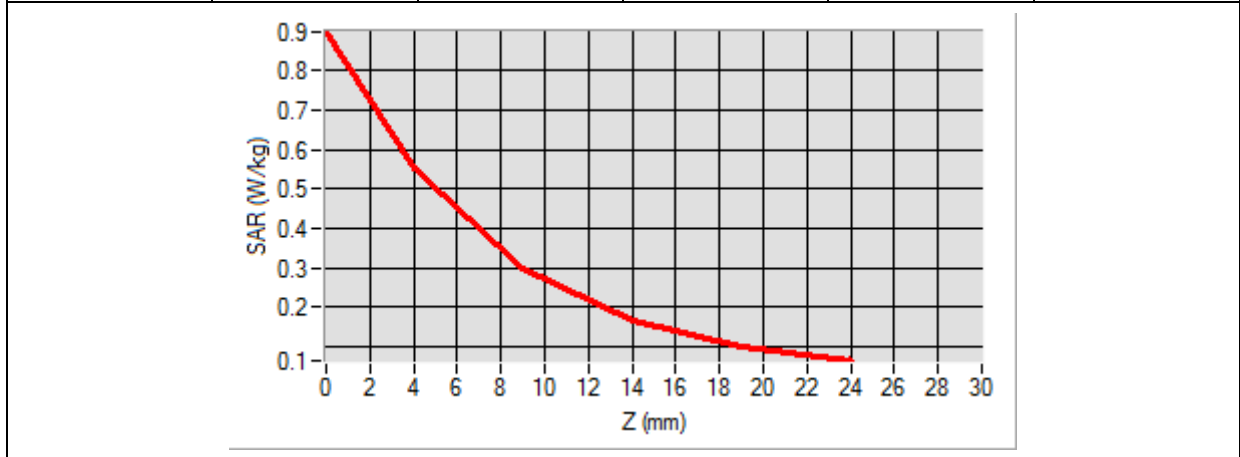

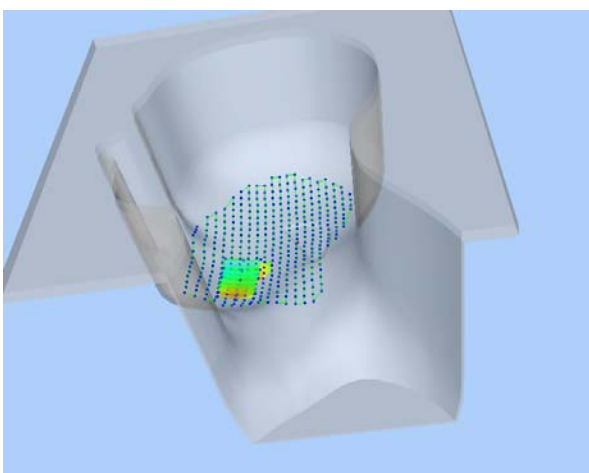
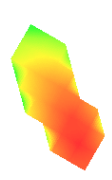
3D screen shot	Hot spot position
	

MEASUREMENT 27

Type: Phone measurement (Complete)

Date of measurement: 09/16/2019

Measurement duration: 12 minutes 3 seconds

E-field Probe: SSE5 - SN 09/13 EP168; ConvF: 6.93; Calibrated: 05/22/2019

A. Experimental conditions

Area Scan	sam_direct_droit2_surf8mm.txt
Phantom	Left head
Device Position	Cheek
Band	WCDMA850_RMC
Channels	Middle
Signal	Duty Cycle 1:1

B. SAR Measurement Results

Frequency (MHz)	836.600000
Relative Permittivity (real part)	41.110245
Conductivity (S/m)	0.871245
Power Variation (%)	1.342427
Ambient Temperature	21.1
Liquid Temperature	21.3

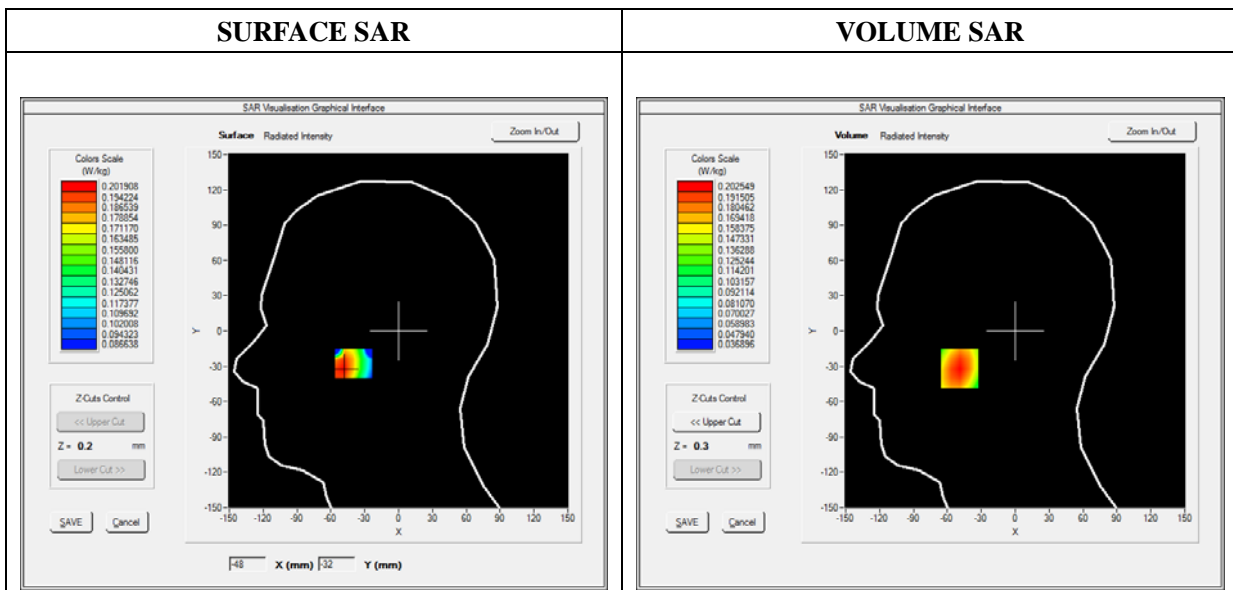



Maximum location: X=-49.00, Y=-32.00

SAR Peak: 0.23 W/kg

SAR 10g (W/Kg)	0.149948
SAR 1g (W/Kg)	0.195579

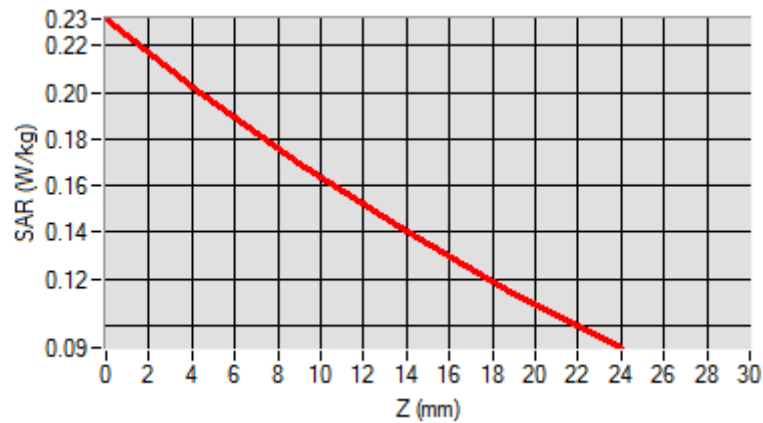
Z (mm)	0.00	4.00	9.00	14.00	19.00
SAR (W/Kg)	0.2314	0.2025	0.1697	0.1403	0.1140

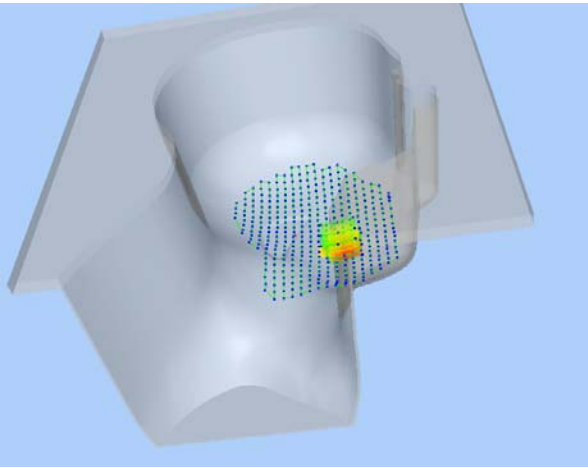

3D screen shot	Hot spot position
	

MEASUREMENT 29

Type: Phone measurement (Complete)

Date of measurement: 09/17/2019

Measurement duration: 12 minutes 3 seconds

E-field Probe: SSE5 - SN 09/13 EP168; ConvF: 5.84; Calibrated: 05/22/2019

A. Experimental conditions

Area Scan	sam_direct_droit2_surf8mm.txt
Phantom	Right head
Device Position	Cheek
Band	WCDMA1700_RMC
Channels	High
Signal	Duty Cycle 1:1

B. SAR Measurement Results

Frequency (MHz)	1752.600000
Relative Permittivity (real part)	39.024890
Conductivity (S/m)	1.371250
Power Variation (%)	1.342427
Ambient Temperature	21.1
Liquid Temperature	21.3

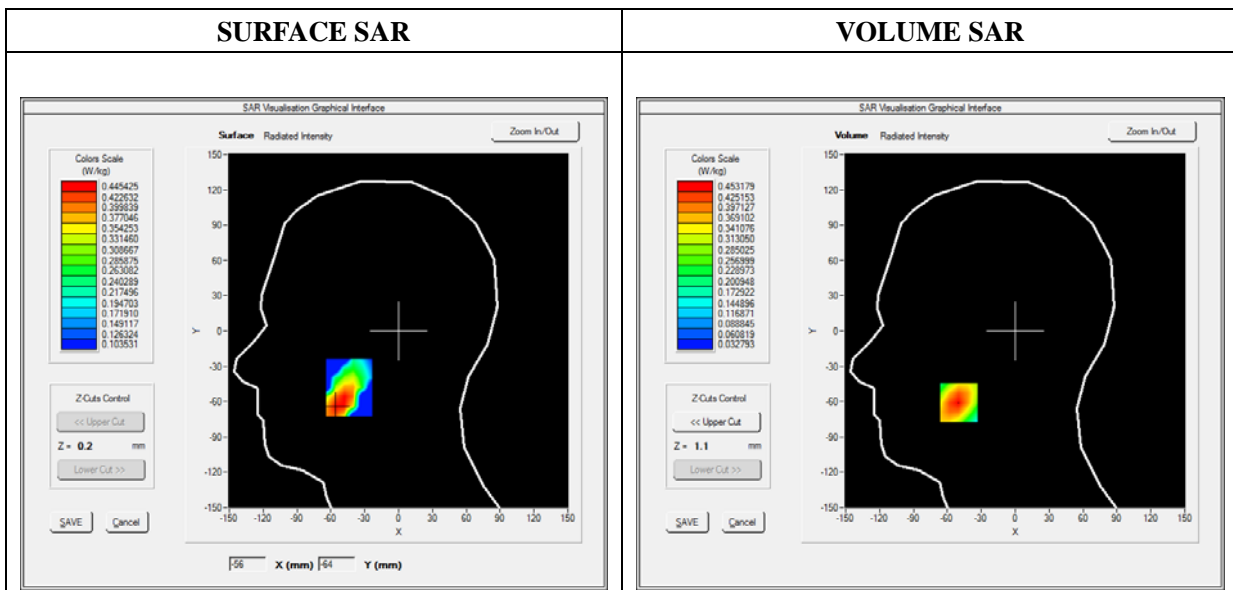

Maximum location: X=-50.00, Y=-61.00

SAR Peak: 0.70 W/kg

SAR 10g (W/Kg)	0.251975
SAR 1g (W/Kg)	0.430483

Z (mm)	0.00	4.00	9.00	14.00	19.00
SAR (W/Kg)	0.7035	0.4532	0.2605	0.1581	0.1074

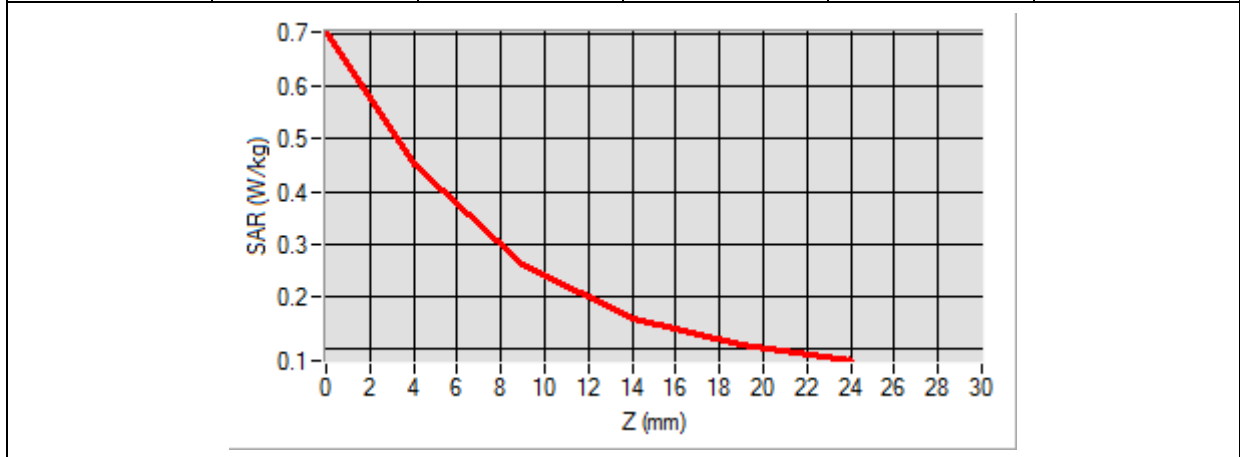

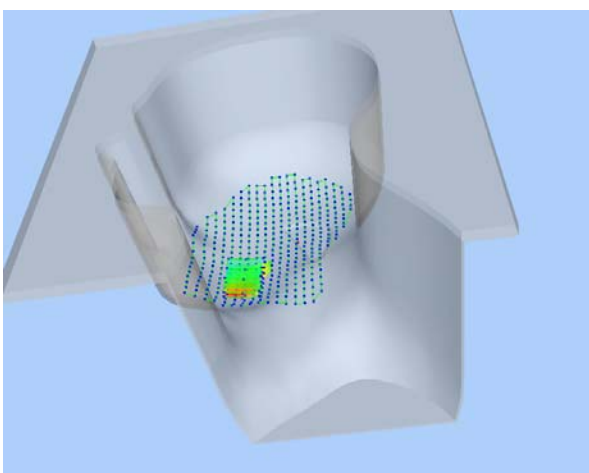
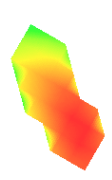
3D screen shot	Hot spot position
	

MEASUREMENT 33

Type: Phone measurement (Complete)

Date of measurement: 09/17/2019

Measurement duration: 12 minutes 3 seconds

E-field Probe: SSE5 - SN 09/13 EP168; ConvF: 6.35; Calibrated: 05/22/2019

A. Experimental conditions

Area Scan	sam_direct_droit2_surf8mm.txt
Phantom	Right head
Device Position	Cheek
Band	LTE Band 2_RMC
Channels	QPSK, 20MHz, 1RB, Low
Signal	Duty Cycle 1:1

B. SAR Measurement Results

Frequency (MHz)	1860.000000
Relative Permittivity (real part)	38.560124
Conductivity (S/m)	1.380369
Power Variation (%)	1.743564
Ambient Temperature	21.1
Liquid Temperature	21.3

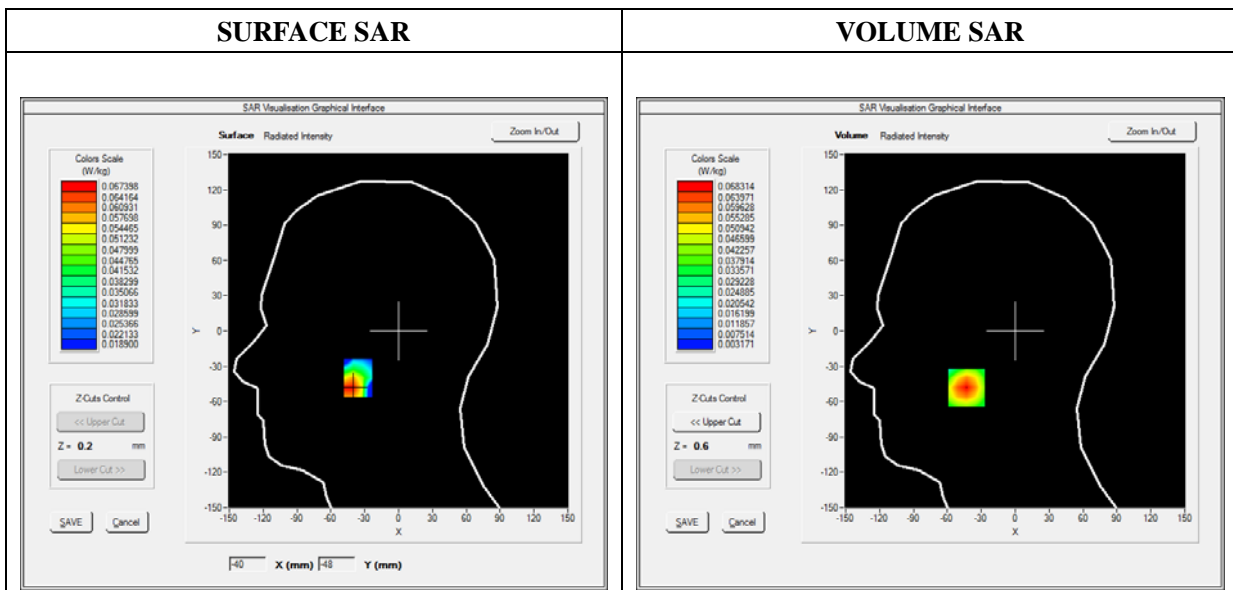

Maximum location: X=-43.00, Y=-48.00

SAR Peak: 0.10 W/kg

SAR 10g (W/Kg)	0.035468
SAR 1g (W/Kg)	0.064071

Z (mm)	0.00	4.00	9.00	14.00	19.00
SAR (W/Kg)	0.1046	0.0683	0.0391	0.0224	0.0131

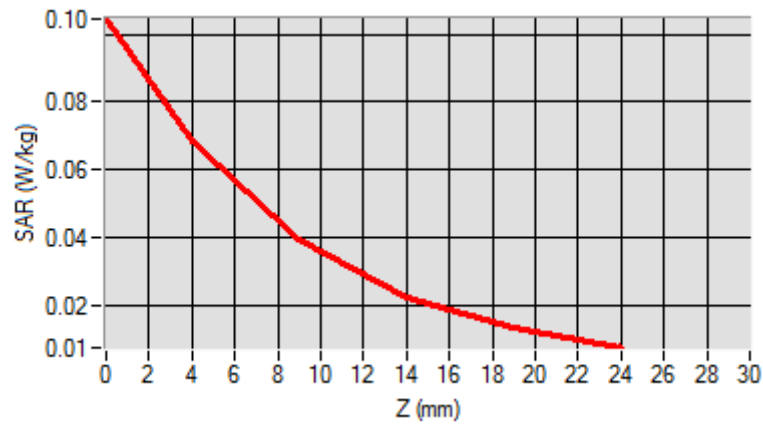

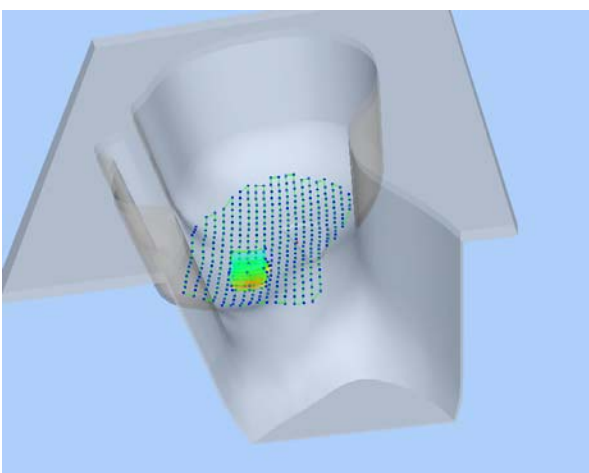
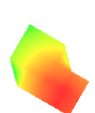
3D screen shot	Hot spot position
	

MEASUREMENT 41

Type: Phone measurement (Complete)

Date of measurement: 09/17/2019

Measurement duration: 12 minutes 3 seconds

E-field Probe: SSE5 - SN 09/13 EP168; ConvF: 5.84; Calibrated: 05/22/2019

A. Experimental conditions

Area Scan	sam_direct_droit2_surf8mm.txt
Phantom	Right head
Device Position	Cheek
Band	LTE Band 4_RMC
Channels	QPSK, 20MHz, 1RB,Low
Signal	Duty Cycle 1:1

B. SAR Measurement Results

Frequency (MHz)	1720.000000
Relative Permittivity (real part)	39.024890
Conductivity (S/m)	1.371250
Power Variation (%)	1.374628
Ambient Temperature	21.1
Liquid Temperature	21.2

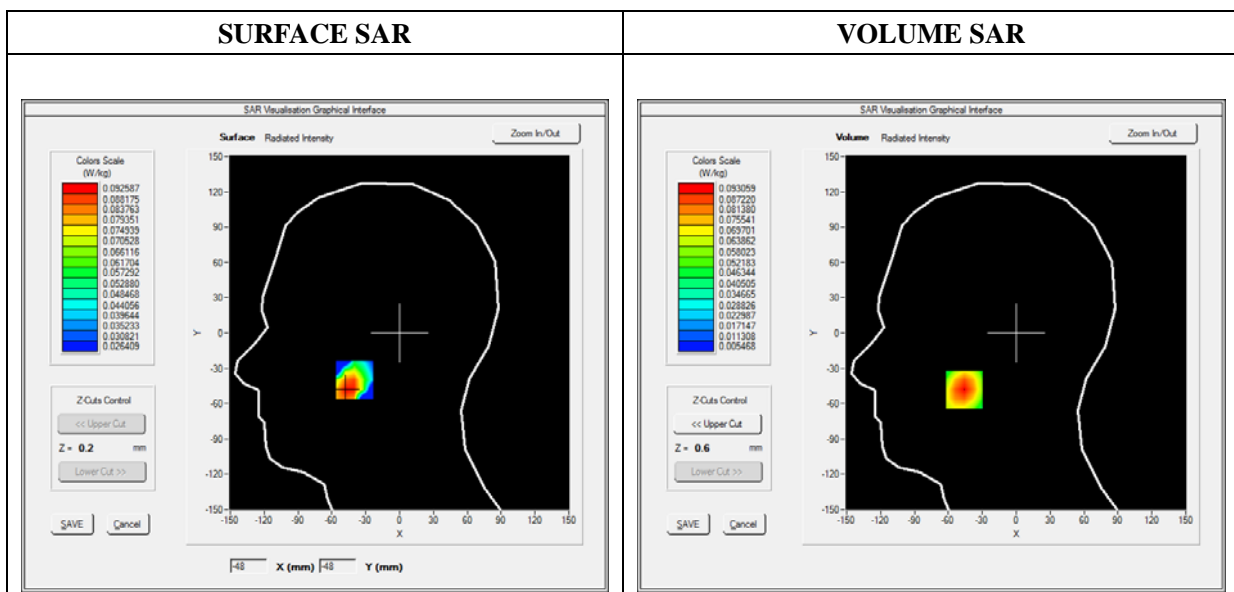

Maximum location: X=-46.00, Y=-48.00

SAR Peak: 0.14 W/kg

SAR 10g (W/Kg)	0.050987
SAR 1g (W/Kg)	0.087837

Z (mm)	0.00	4.00	9.00	14.00	19.00
SAR (W/Kg)	0.1396	0.0931	0.0551	0.0329	0.0203

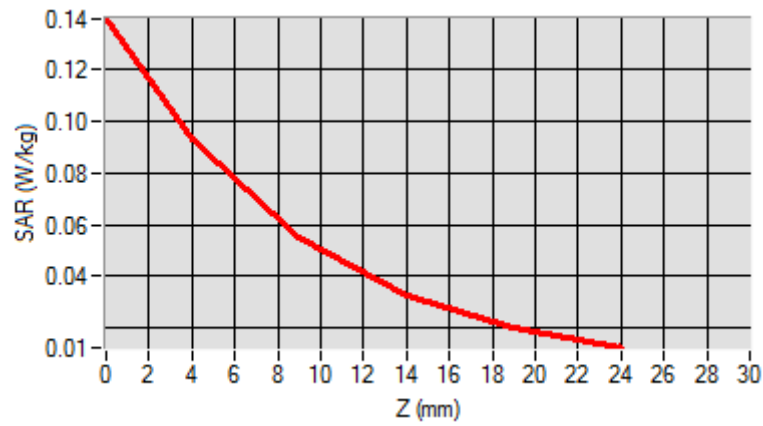

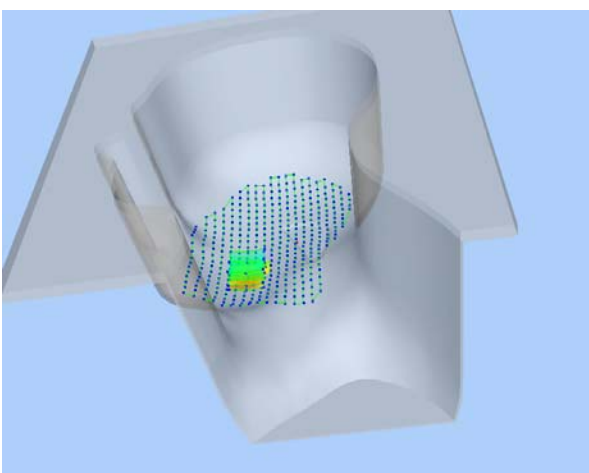
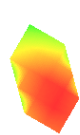
3D screen shot	Hot spot position
	

MEASUREMENT 49

Type: Phone measurement (Complete)

Date of measurement: 09/16/2019

Measurement duration: 12 minutes 3 seconds

E-field Probe: SSE5 - SN 09/13 EP168; ConvF: 6.93; Calibrated: 05/22/2019

A. Experimental conditions

Area Scan	sam_direct_droit2_surf8mm.txt
Phantom	Right head
Device Position	Cheek
Band	LTE Band 5_RMC
Channels	QPSK, 10MHz, 1RB, Low
Signal	Duty Cycle 1:1

B. SAR Measurement Results

Frequency (MHz)	829.000000
Relative Permittivity (real part)	41.110245
Conductivity (S/m)	0.871245
Power Variation (%)	0.924535
Ambient Temperature	21.1
Liquid Temperature	21.2

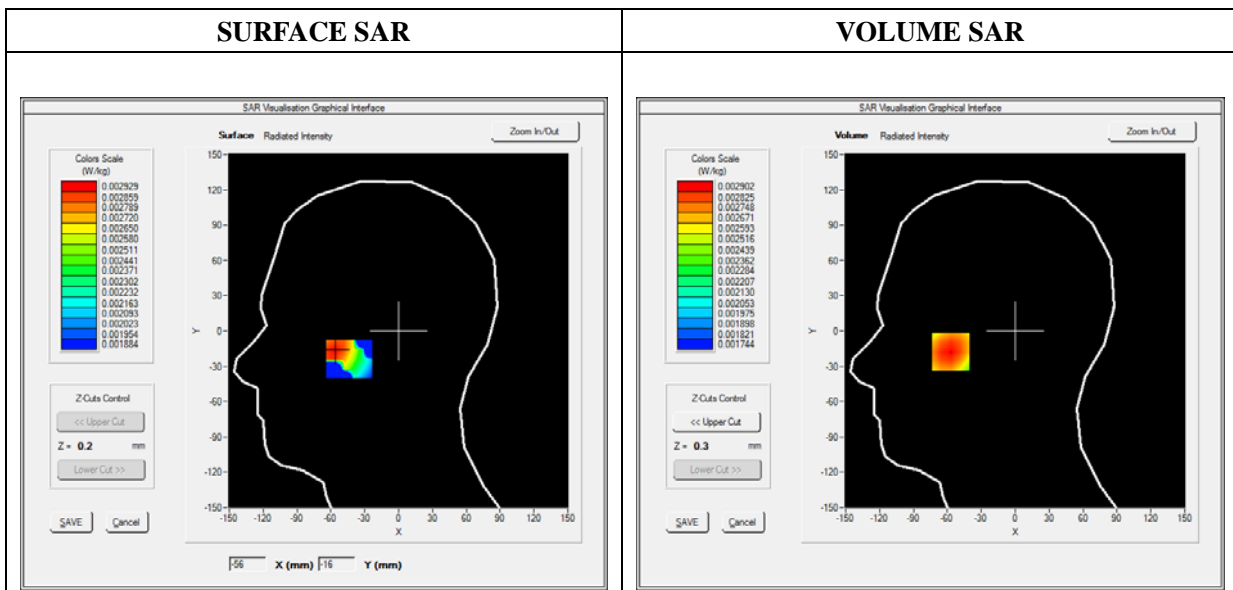

Maximum location: X=-57.00, Y=-17.00

SAR Peak: 0.00 W/kg

SAR 10g (W/Kg)	0.002509
SAR 1g (W/Kg)	0.002852

Z (mm)	0.00	4.00	9.00	14.00	19.00
SAR (W/Kg)	0.0032	0.0029	0.0026	0.0024	0.0022

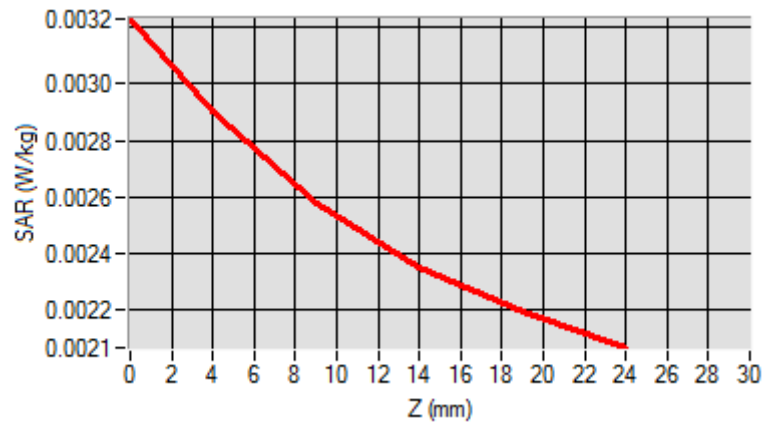

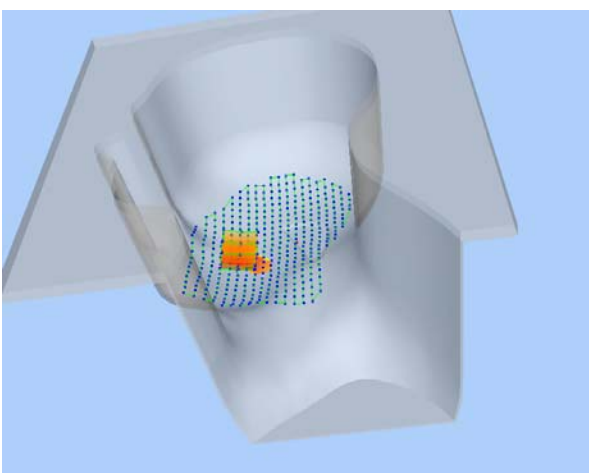
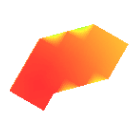
<p style="text-align: center;">3D screen shot</p>	<p style="text-align: center;">Hot spot position</p>
	

MEASUREMENT 57

Type: Phone measurement (Complete)

Date of measurement: 09/18/2019

Measurement duration: 12 minutes 3 seconds

E-field Probe: SSE5 - SN 09/13 EP168; ConvF: 5.37; Calibrated: 05/22/2019

A. Experimental conditions

Area Scan	sam_direct_droit2_surf8mm.txt
Phantom	Right head
Device Position	Cheek
Band	LTE Band 7_RMC
Channels	QPSK, 20MHz, 1RB, High
Signal	Duty Cycle 1:1

B. SAR Measurement Results

Frequency (MHz)	2560.000000
Relative Permittivity (real part)	38.631092
Conductivity (S/m)	1.930182
Power Variation (%)	0.924535
Ambient Temperature	21.1
Liquid Temperature	21.2

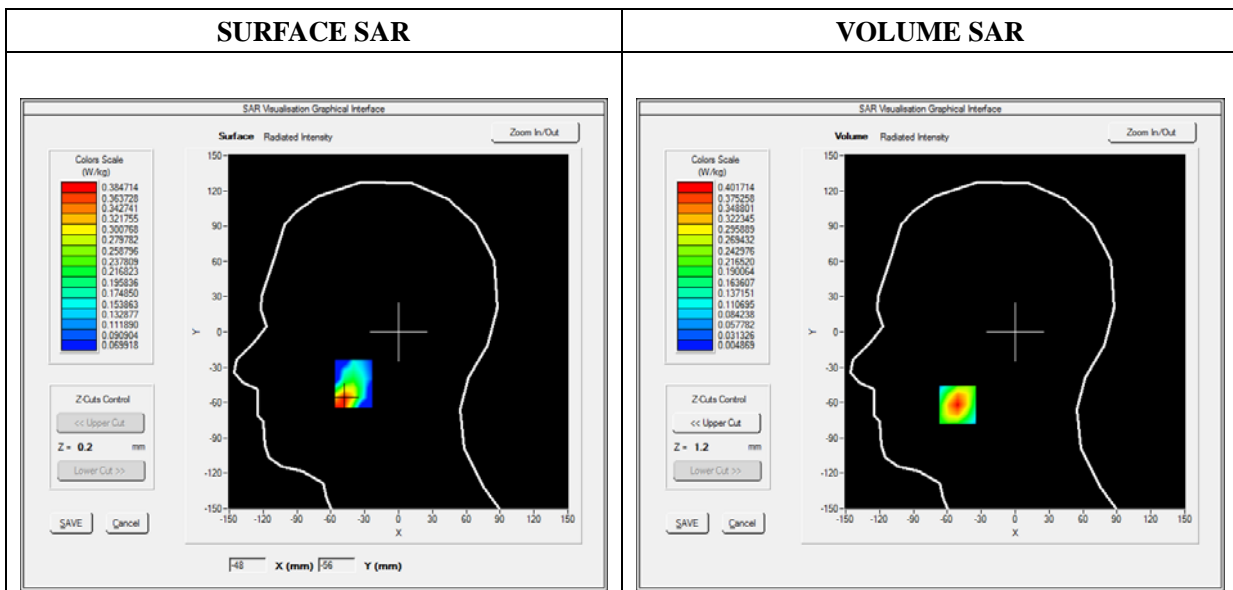

Maximum location: X=-51.00, Y=-62.00

SAR Peak: 0.67 W/kg

SAR 10g (W/Kg)	0.186070
SAR 1g (W/Kg)	0.373223

Z (mm)	0.00	4.00	9.00	14.00	19.00
SAR (W/Kg)	0.6682	0.4017	0.2037	0.1029	0.0550

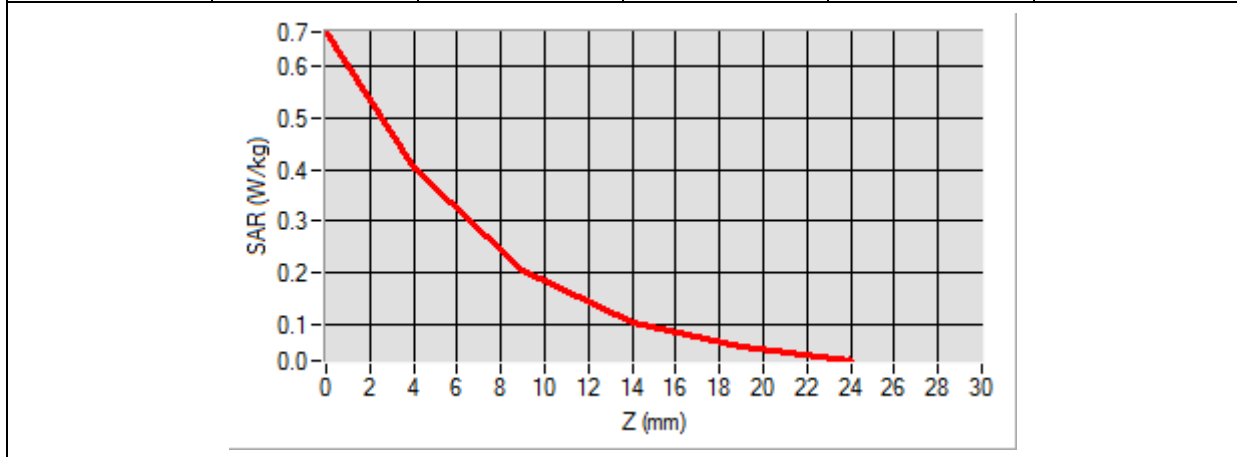

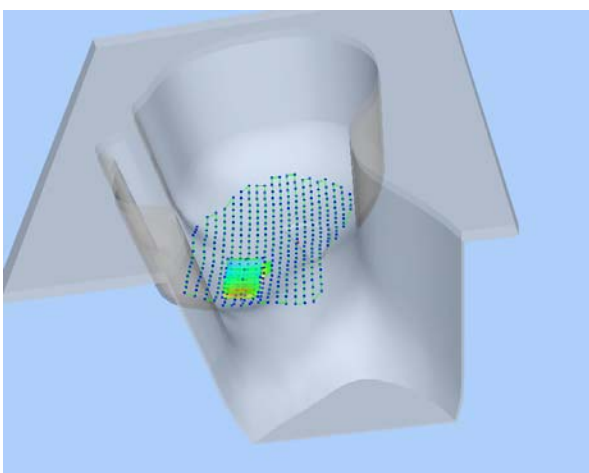
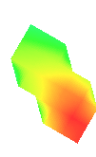
3D screen shot	Hot spot position
	

MEASUREMENT 67

Type: Phone measurement (Complete)

Date of measurement: 09/16/2019

Measurement duration: 12 minutes 3 seconds

E-field Probe: SSE5 - SN 09/13 EP168; ConvF: 6.99; Calibrated: 05/22/2019

A. Experimental conditions

Area Scan	sam_direct_droit2_surf8mm.txt
Phantom	Left head
Device Position	Cheek
Band	LTE Band 12_RMC
Channels	QPSK, 10MHz, 1RB, Middle
Signal	Duty Cycle 1:1

B. SAR Measurement Results

Frequency (MHz)	707.500000
Relative Permittivity (real part)	41.320574
Conductivity (S/m)	0.862373
Power Variation (%)	0.924535
Ambient Temperature	21.1
Liquid Temperature	21.2

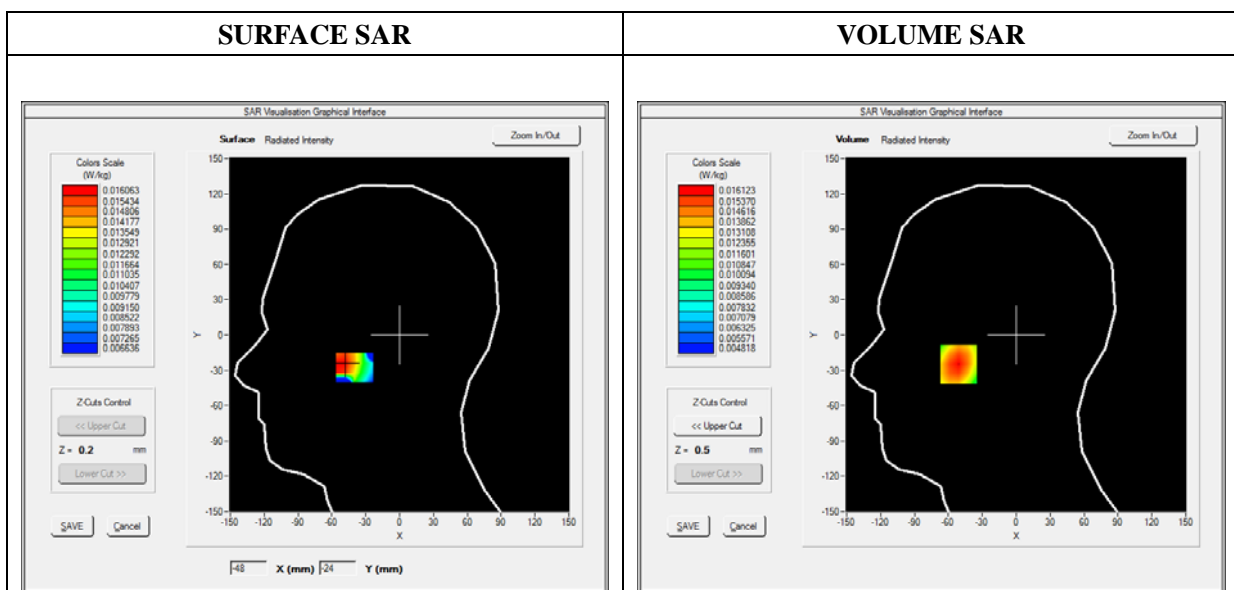



Maximum location: X=-51.00, Y=-25.00

SAR Peak: 0.02 W/kg

SAR 10g (W/Kg)	0.012125
SAR 1g (W/Kg)	0.015602

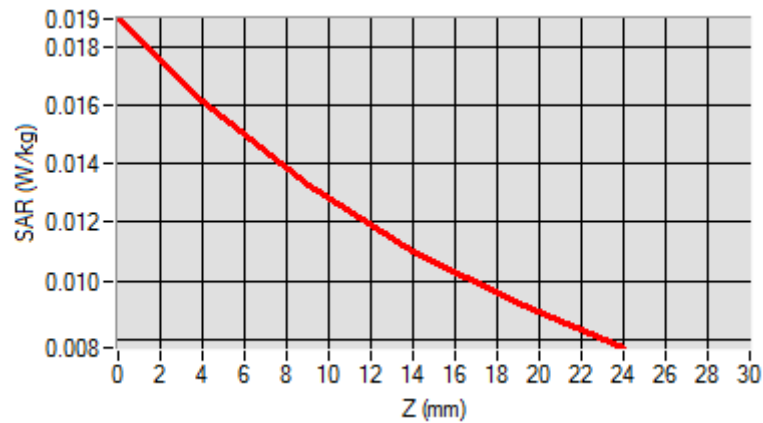
Z (mm)	0.00	4.00	9.00	14.00	19.00
SAR (W/Kg)	0.0190	0.0161	0.0132	0.0110	0.0092

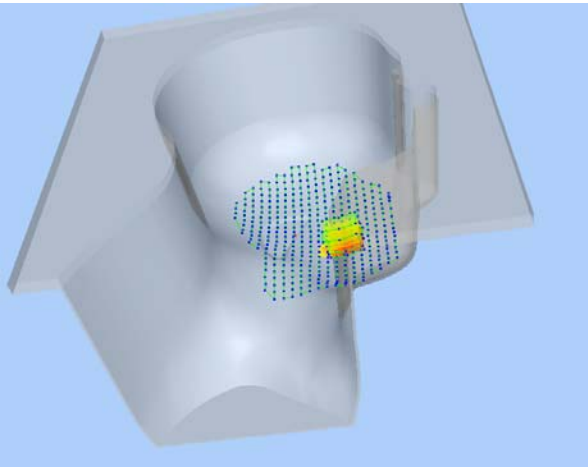

3D screen shot	Hot spot position
	

MEASUREMENT 75

Type: Phone measurement (Complete)

Date of measurement: 09/16/2019

Measurement duration: 12 minutes 3 seconds

E-field Probe: SSE5 - SN 09/13 EP168; ConvF: 6.99; Calibrated: 05/22/2019

A. Experimental conditions

Area Scan	sam_direct_droit2_surf8mm.txt
Phantom	Left head
Device Position	Cheek
Band	LTE Band 13_RMC
Channels	QPSK, 10MHz, 1RB, Middle
Signal	Duty Cycle 1:1

B. SAR Measurement Results

Frequency (MHz)	782.000000
Relative Permittivity (real part)	41.320574
Conductivity (S/m)	0.862373
Power Variation (%)	0.924535
Ambient Temperature	21.1
Liquid Temperature	21.2

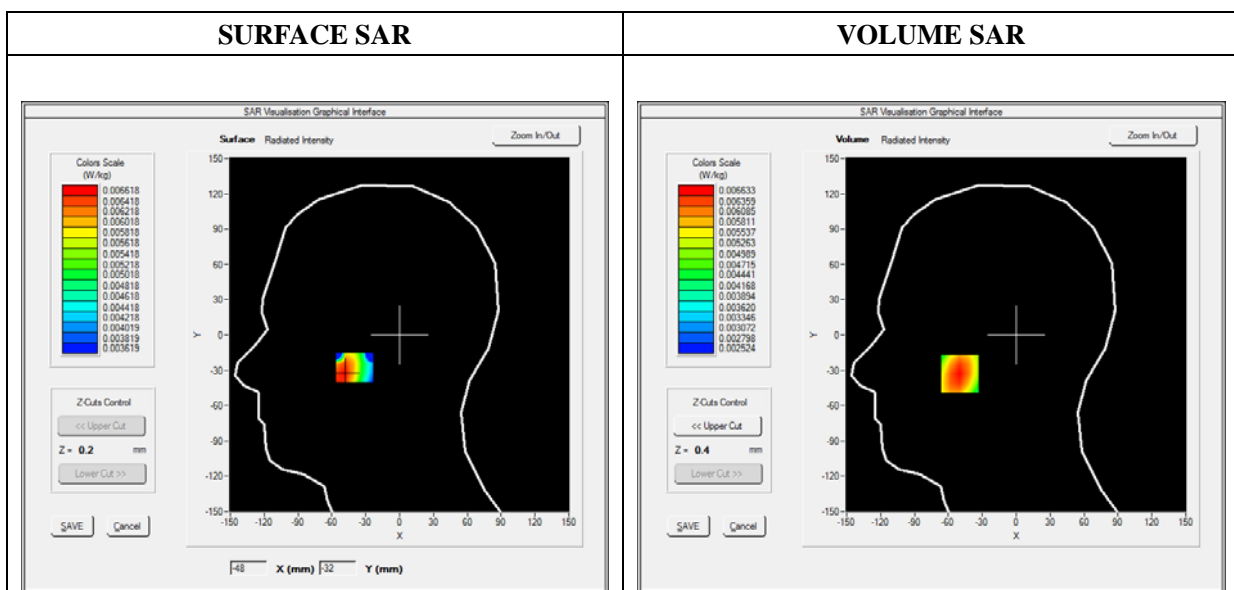



Maximum location: X=-50.00, Y=-33.00

SAR Peak: 0.01 W/kg

SAR 10g (W/Kg)	0.005170
SAR 1g (W/Kg)	0.006436

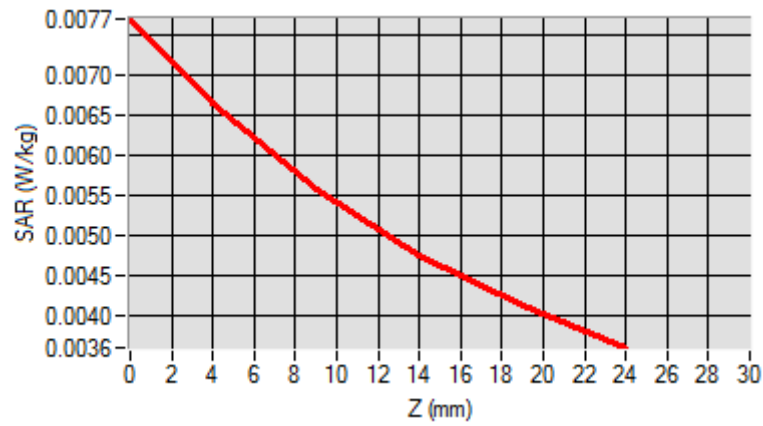
Z (mm)	0.00	4.00	9.00	14.00	19.00
SAR (W/Kg)	0.0077	0.0066	0.0056	0.0047	0.0041

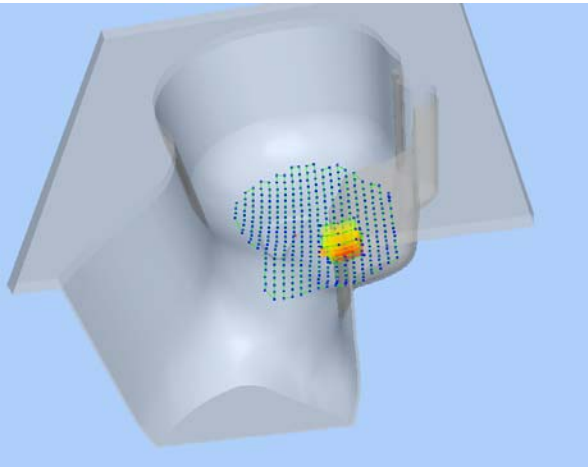

<p align="center">3D screen shot</p>	<p align="center">Hot spot position</p>
	

MEASUREMENT 83

Type: Phone measurement (Complete)

Date of measurement: 09/16/2019

Measurement duration: 12 minutes 3 seconds

E-field Probe: SSE5 - SN 09/13 EP168; ConvF: 6.99; Calibrated: 05/22/2019

A. Experimental conditions

Area Scan	sam_direct_droit2_surf8mm.txt
Phantom	Left head
Device Position	Cheek
Band	LTE Band 17_RMC
Channels	QPSK, 5MHz, 1RB, High
Signal	Duty Cycle 1:1

B. SAR Measurement Results

Frequency (MHz)	713.500000
Relative Permittivity (real part)	41.320574
Conductivity (S/m)	0.862373
Power Variation (%)	0.924535
Ambient Temperature	21.1
Liquid Temperature	21.2

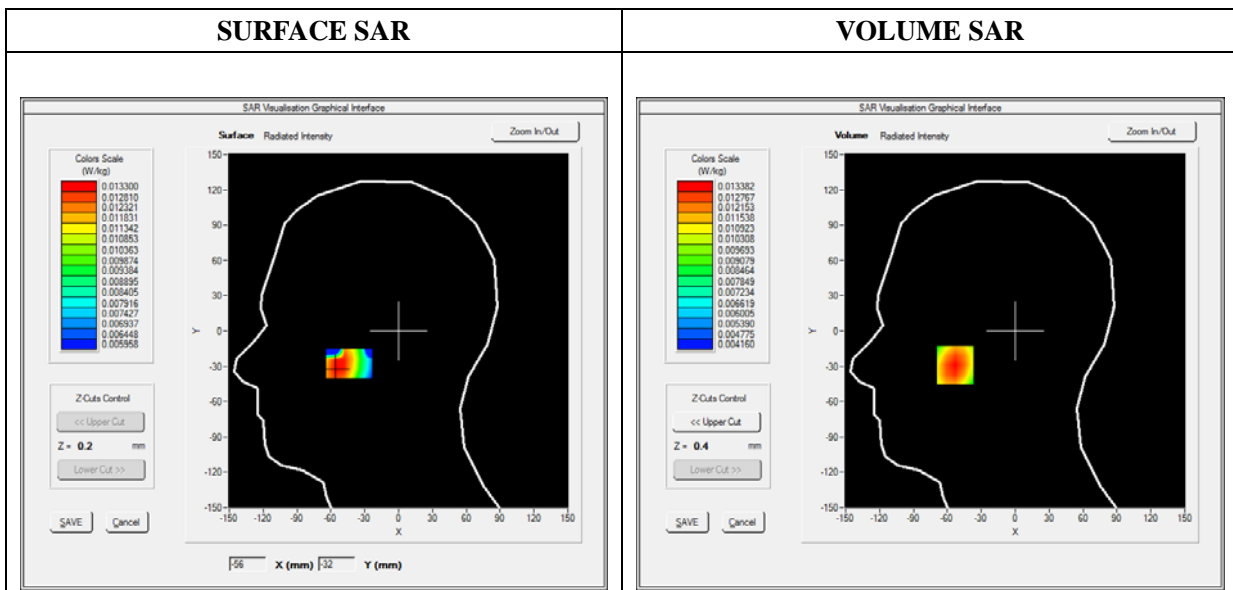



Maximum location: X=-53.00, Y=-29.00

SAR Peak: 0.02 W/kg

SAR 10g (W/Kg)	0.010337
SAR 1g (W/Kg)	0.013197

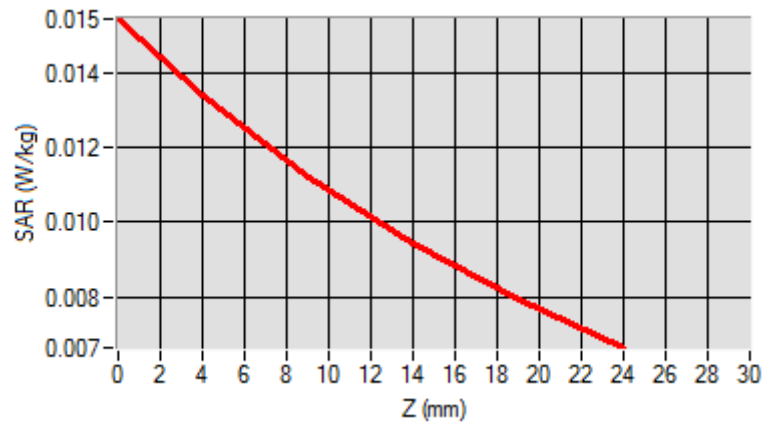
Z (mm)	0.00	4.00	9.00	14.00	19.00
SAR (W/Kg)	0.0154	0.0134	0.0112	0.0094	0.0079

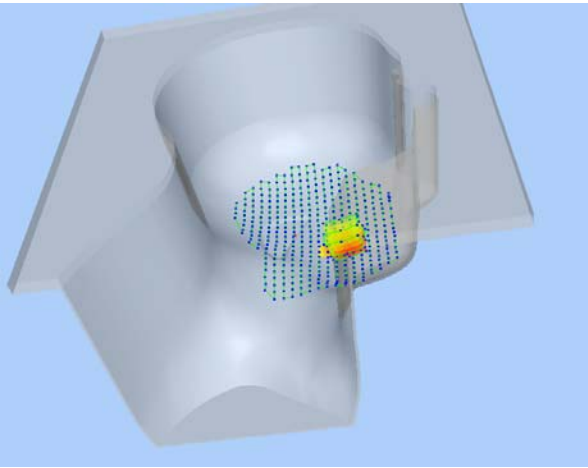

3D screen shot	Hot spot position
	

MEASUREMENT 89

Type: Phone measurement (Complete)

Date of measurement: 09/17/2019

Measurement duration: 12 minutes 3 seconds

E-field Probe: SSE5 - SN 09/13 EP168; ConvF: 6.35; Calibrated: 05/22/2019

A. Experimental conditions

Area Scan	sam_direct_droit2_surf8mm.txt
Phantom	Left head
Device Position	Cheek
Band	LTE Band 25_RMC
Channels	QPSK, 10MHz, 1RB, Low
Signal	Duty Cycle 1:1

B. SAR Measurement Results

Frequency (MHz)	1855.000000
Relative Permittivity (real part)	38.560124
Conductivity (S/m)	1.380369
Power Variation (%)	1.743564
Ambient Temperature	21.1
Liquid Temperature	21.3

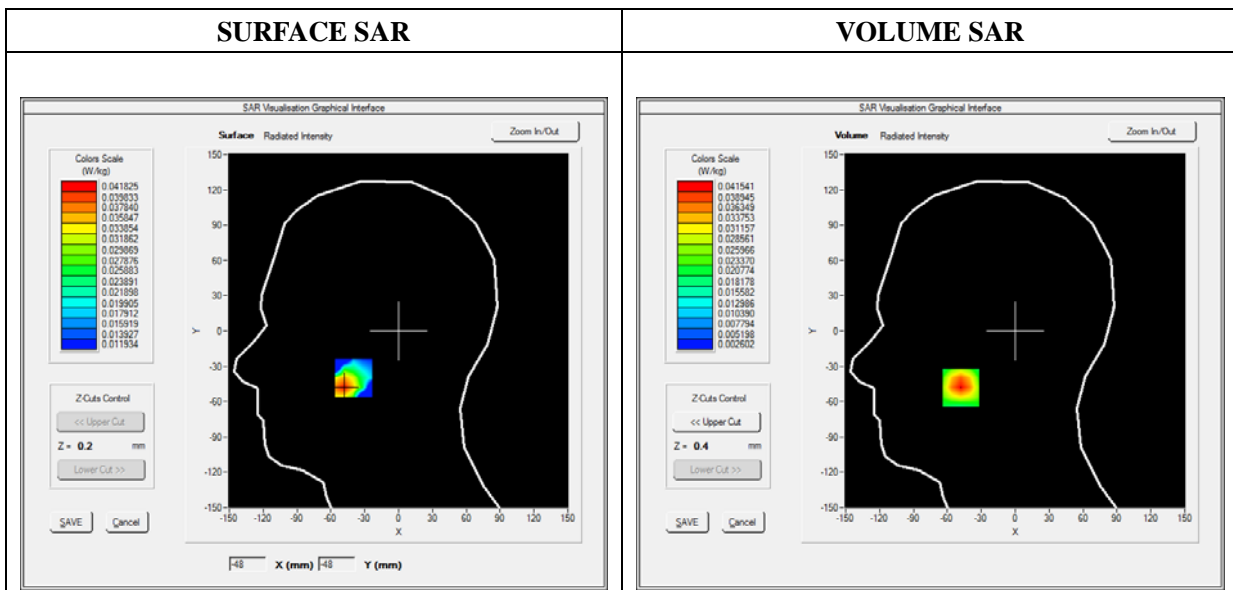

Maximum location: X=-48.00, Y=-48.00

SAR Peak: 0.07 W/kg

SAR 10g (W/Kg)	0.021239
SAR 1g (W/Kg)	0.039129

Z (mm)	0.00	4.00	9.00	14.00	19.00
SAR (W/Kg)	0.0664	0.0415	0.0225	0.0124	0.0074

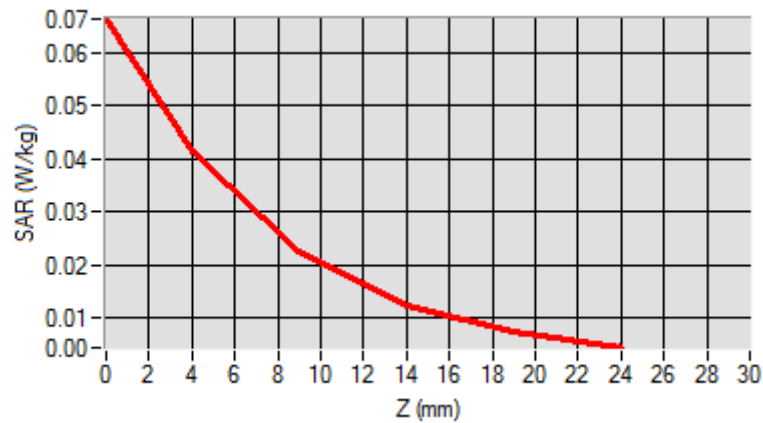

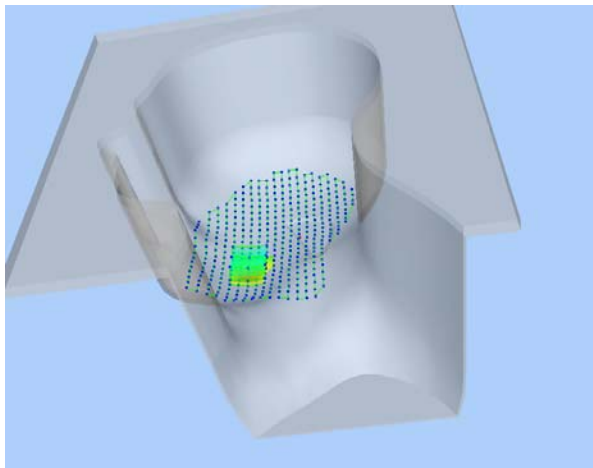
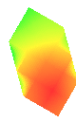
3D screen shot	Hot spot position
	

MEASUREMENT 99

Type: Phone measurement (Complete)

Date of measurement: 09/16/2019

Measurement duration: 12 minutes 3 seconds

E-field Probe: SSE5 - SN 09/13 EP168; ConvF: 6.93; Calibrated: 05/22/2019

A. Experimental conditions

Area Scan	sam_direct_droit2_surf8mm.txt
Phantom	Left head
Device Position	Cheek
Band	LTE Band 26_RMC
Channels	QPSK, 10MHz, 1RB, Middle
Signal	Duty Cycle 1:1

B. SAR Measurement Results

Frequency (MHz)	831.000000
Relative Permittivity (real part)	41.110245
Conductivity (S/m)	0.871245
Power Variation (%)	0.821534
Ambient Temperature	21.1
Liquid Temperature	21.2

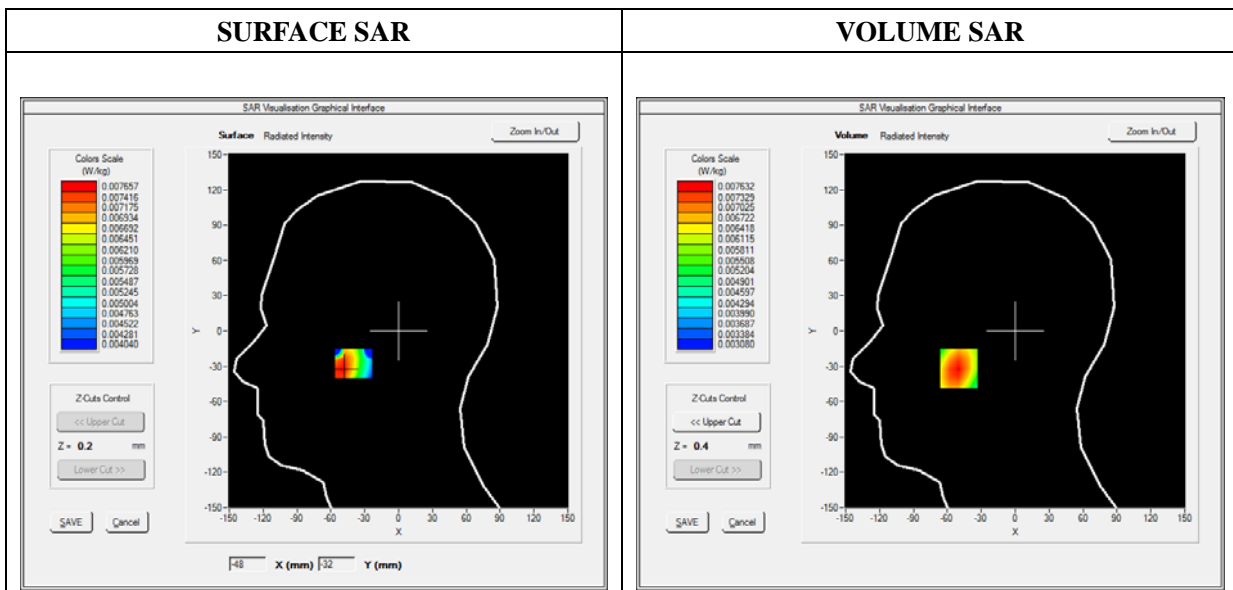



Maximum location: X=-50.00, Y=-32.00

SAR Peak: 0.01 W/kg

SAR 10g (W/Kg)	0.005989
SAR 1g (W/Kg)	0.007424

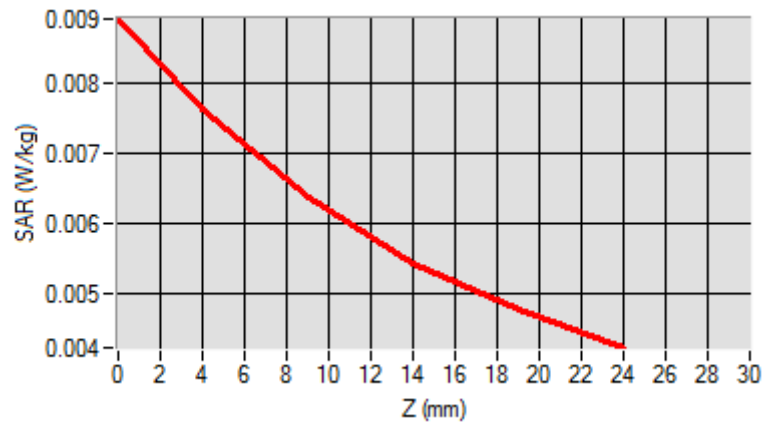
Z (mm)	0.00	4.00	9.00	14.00	19.00
SAR (W/Kg)	0.0089	0.0076	0.0064	0.0054	0.0048

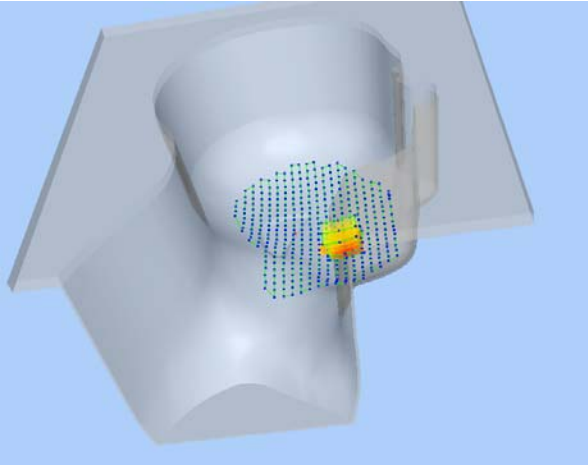

3D screen shot	Hot spot position
	

MEASUREMENT 105

Type: Phone measurement (Complete)

Date of measurement: 09/18/2019

Measurement duration: 12 minutes 3 seconds

E-field Probe: SSE5 - SN 09/13 EP168; ConvF: 5.37; Calibrated: 05/22/2019

A. Experimental conditions

Area Scan	sam_direct_droit2_surf8mm.txt
Phantom	Left head
Device Position	Cheek
Band	LTE Band 30_RMC
Channels	QPSK, 10MHz, 1RB, Middle
Signal	Duty Cycle 1:1

B. SAR Measurement Results

Frequency (MHz)	2310.000000
Relative Permittivity (real part)	38.153660
Conductivity (S/m)	1.740236
Power Variation (%)	3.027673
Ambient Temperature	21.1
Liquid Temperature	21.2

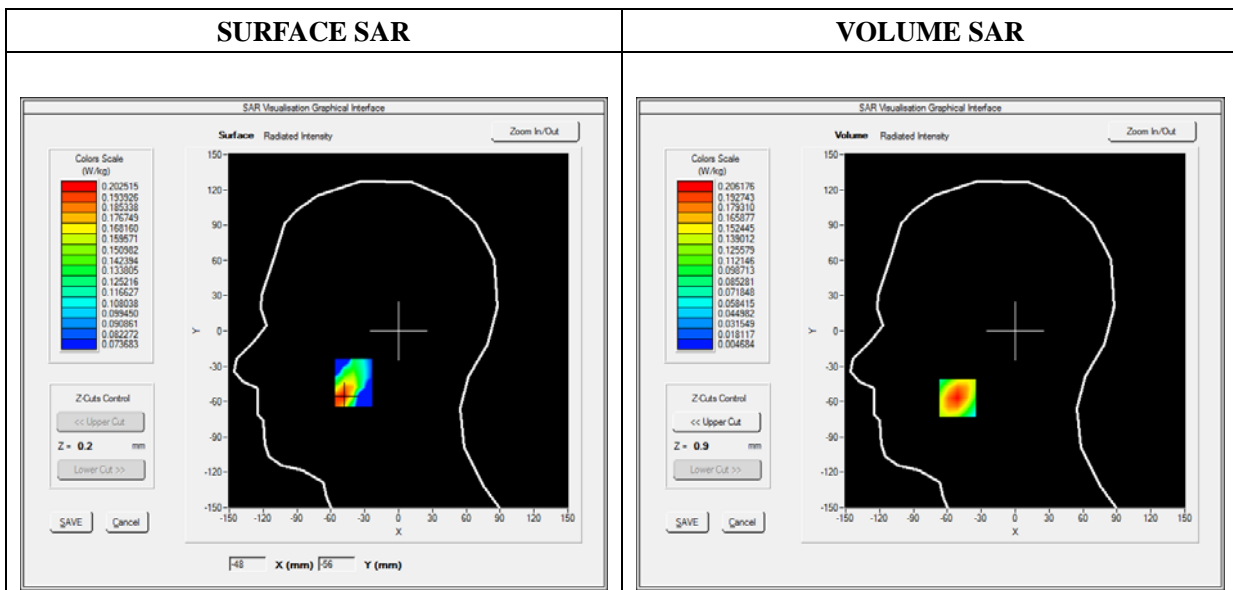

Maximum location: X=-51.00, Y=-57.00

SAR Peak: 0.36 W/kg

SAR 10g (W/Kg)	0.099048
SAR 1g (W/Kg)	0.194658

Z (mm)	0.00	4.00	9.00	14.00	19.00
SAR (W/Kg)	0.3570	0.2062	0.0980	0.0459	0.0230

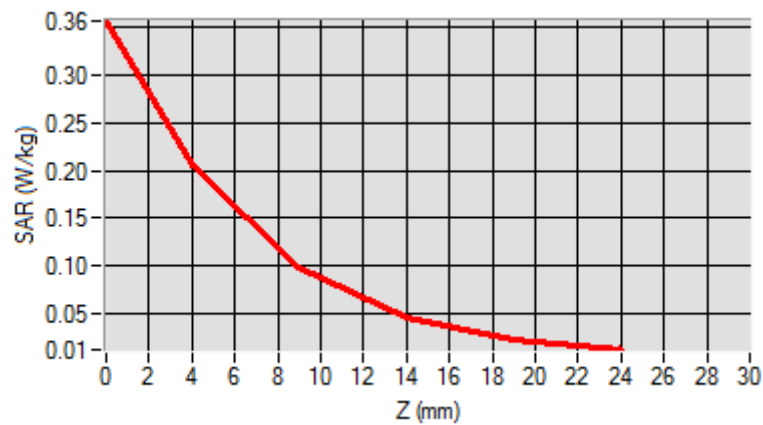

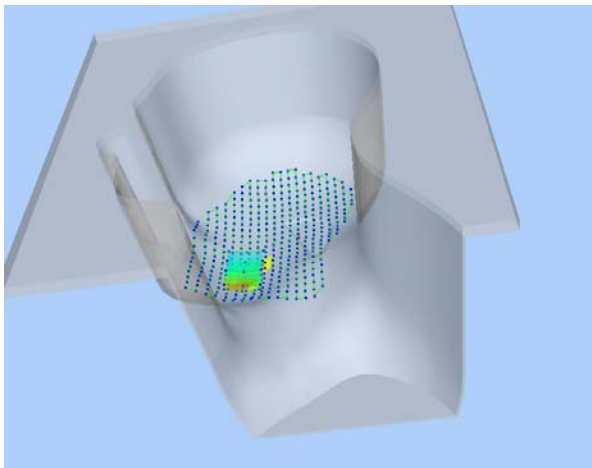
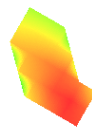
3D screen shot	Hot spot position
	

MEASUREMENT 113

Type: Phone measurement (Complete)

Date of measurement: 09/18/2019

Measurement duration: 12 minutes 3 seconds

E-field Probe: SSE5 - SN 09/13 EP168; ConvF: 5.64; Calibrated: 05/22/2019

A. Experimental conditions

Area Scan	sam_direct_droit2_surf8mm.txt
Phantom	Right head
Device Position	Cheek
Band	LTE Band 40_RMC
Channels	QPSK, 10MHz, 1RB, Middle
Signal	Duty Cycle 1:1

B. SAR Measurement Results

Frequency (MHz)	2310.000000
Relative Permittivity (real part)	38.153660
Conductivity (S/m)	1.740236
Power Variation (%)	3.010112
Ambient Temperature	21.1
Liquid Temperature	21.2

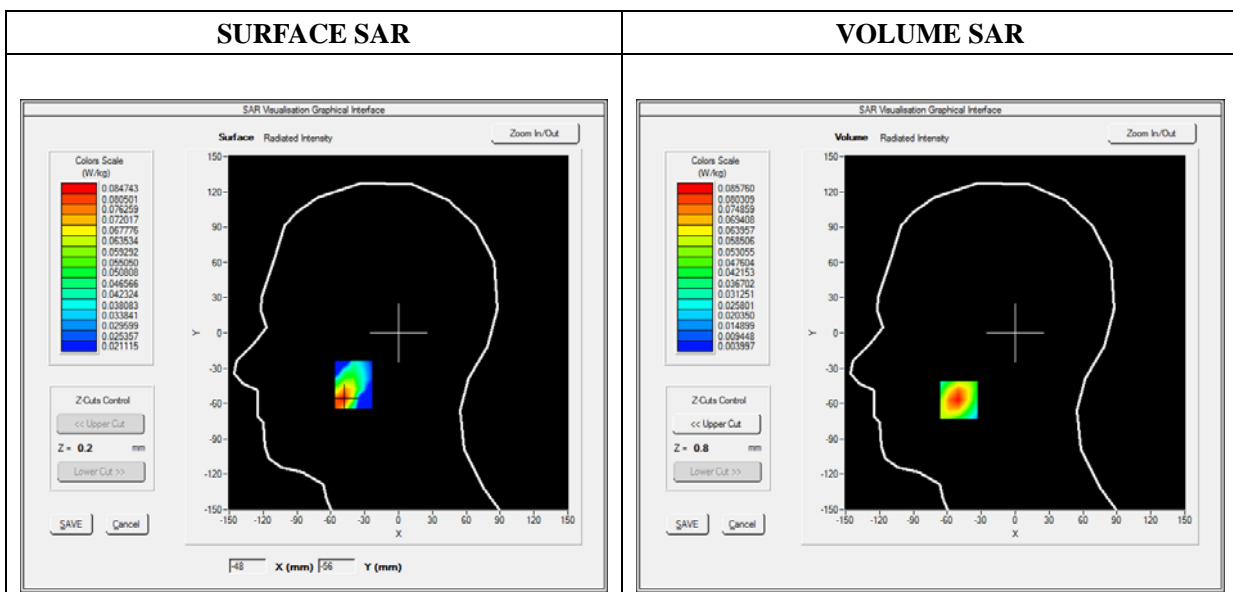

Maximum location: X=-50.00, Y=-57.00

SAR Peak: 0.15 W/kg

SAR 10g (W/Kg)	0.040264
SAR 1g (W/Kg)	0.080890

Z (mm)	0.00	4.00	9.00	14.00	19.00
SAR (W/Kg)	0.1485	0.0858	0.0407	0.0189	0.0093

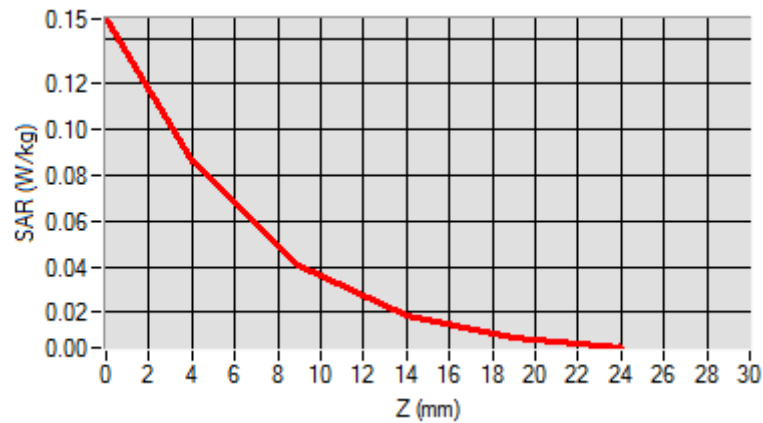

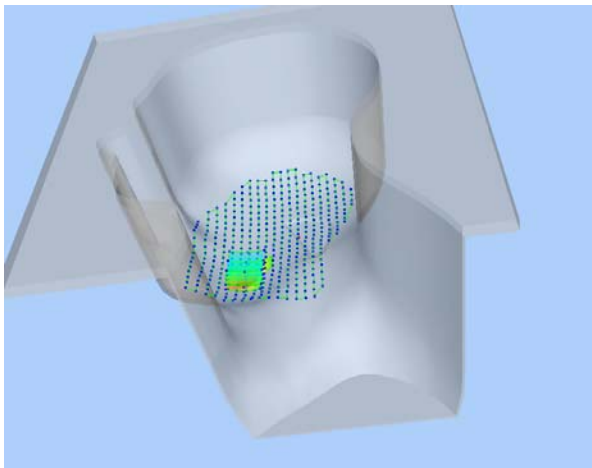
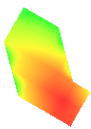
3D screen shot	Hot spot position
	

MEASUREMENT 121

Type: Phone measurement (Complete)

Date of measurement: 09/18/2019

Measurement duration: 12 minutes 3 seconds

E-field Probe: SSE5 - SN 09/13 EP168; ConvF: 5.64; Calibrated: 05/22/2019

A. Experimental conditions

Area Scan	sam_direct_droit2_surf8mm.txt
Phantom	Right head
Device Position	Cheek
Band	LTE Band 40_RMC
Channels	QPSK, 10MHz, 1RB, Middle
Signal	Duty Cycle 1:1

B. SAR Measurement Results

Frequency (MHz)	2355.000000
Relative Permittivity (real part)	38.153660
Conductivity (S/m)	1.740236
Power Variation (%)	3.027673
Ambient Temperature	21.1
Liquid Temperature	21.2

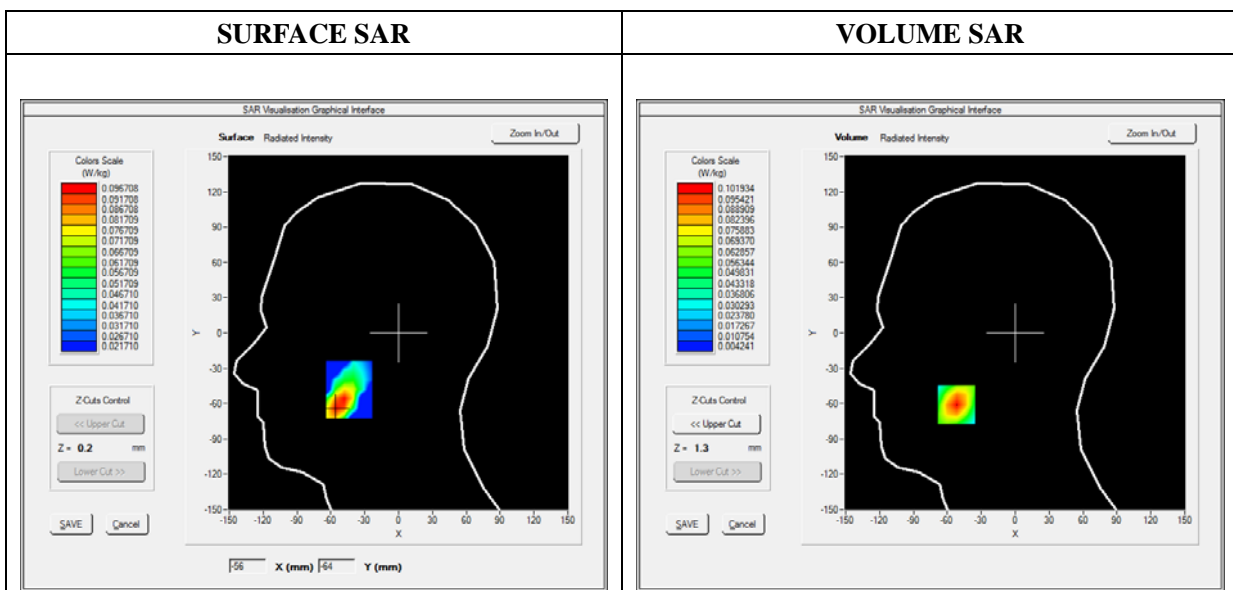

Maximum location: X=-52.00, Y=-61.00

SAR Peak: 0.16 W/kg

SAR 10g (W/Kg)	0.049897
SAR 1g (W/Kg)	0.094803

Z (mm)	0.00	4.00	9.00	14.00	19.00
SAR (W/Kg)	0.1625	0.1019	0.0550	0.0295	0.0164

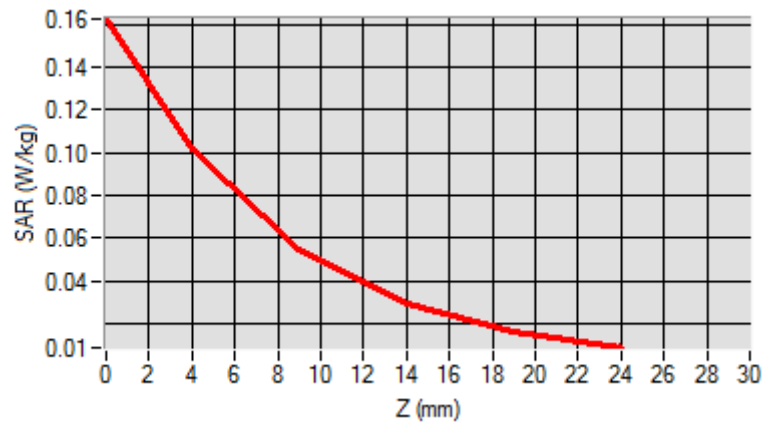

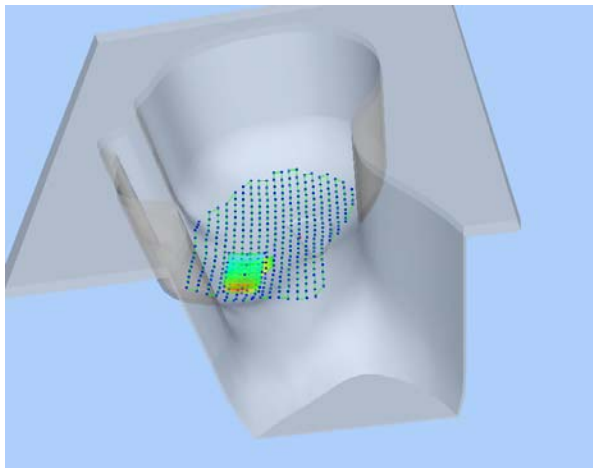
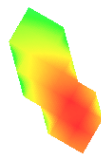
3D screen shot	Hot spot position
	

MEASUREMENT 129

Type: Phone measurement (Complete)

Date of measurement: 09/17/2019

Measurement duration: 12 minutes 3 seconds

E-field Probe: SSE5 - SN 09/13 EP168; ConvF: 5.37; Calibrated: 05/22/2019

A. Experimental conditions

Area Scan	sam_direct_droit2_surf8mm.txt
Phantom	Right head
Device Position	Cheek
Band	LTE Band 66_RMC
Channels	QPSK, 5MHz, 1RB, Low
Signal	Duty Cycle 1:1

B. SAR Measurement Results

Frequency (MHz)	1712.500000
Relative Permittivity (real part)	38.153660
Conductivity (S/m)	1.740236
Power Variation (%)	3.027673
Ambient Temperature	21.1
Liquid Temperature	21.2

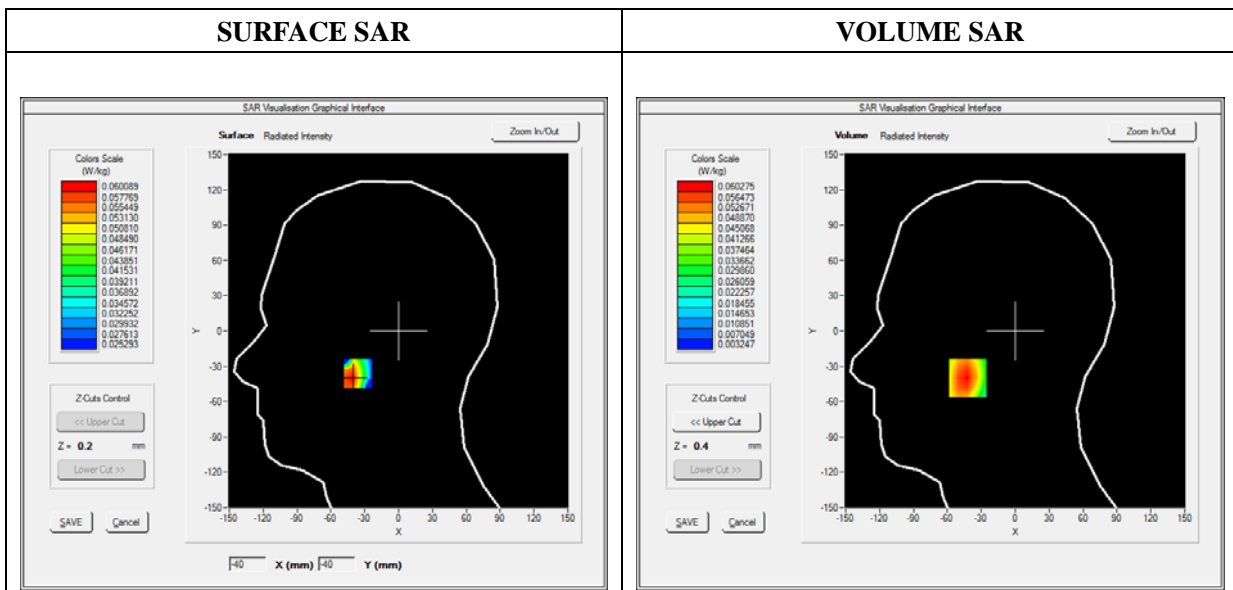



Maximum location: X=-42.00, Y=-40.00

SAR Peak: 0.09 W/kg

SAR 10g (W/Kg)	0.034513
SAR 1g (W/Kg)	0.057441

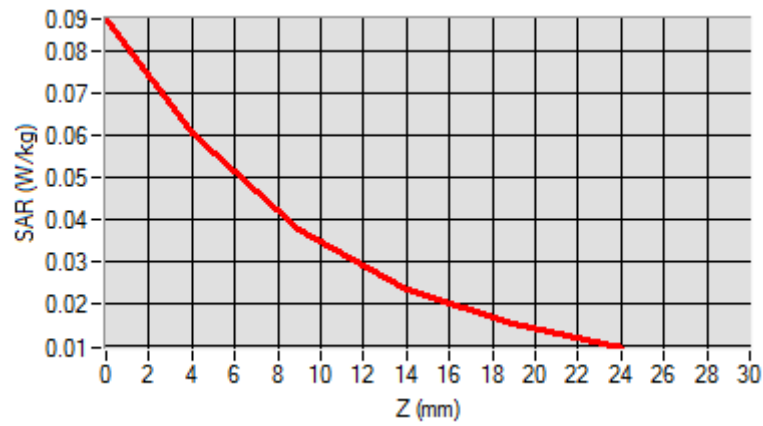
Z (mm)	0.00	4.00	9.00	14.00	19.00
SAR (W/Kg)	0.0874	0.0603	0.0374	0.0233	0.0149

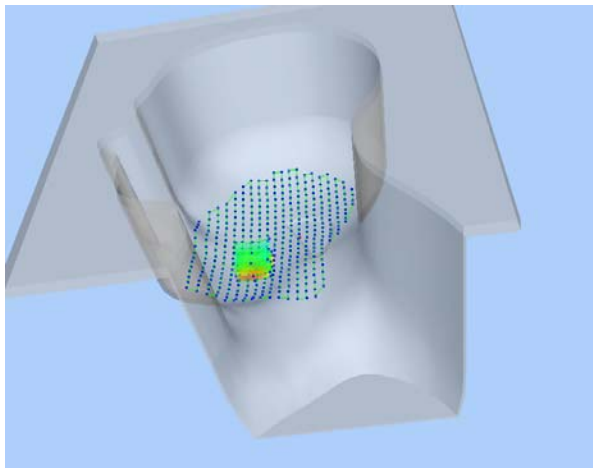

3D screen shot	Hot spot position
	

MEASUREMENT 137

Type: Phone measurement (Complete)

Date of measurement: 09/18/2019

Measurement duration: 12 minutes 3 seconds

E-field Probe: SSE5 - SN 09/13 EP168; ConvF: 5.64; Calibrated: 05/22/2019

A. Experimental conditions

Area Scan	sam_direct_droit2_surf8mm.txt
Phantom	Right head
Device Position	Cheek
Band	WiFi_802.11b
Channels	High
Signal	Duty Cycle 1:1

B. SAR Measurement Results

Frequency (MHz)	2462.000000
Relative Permittivity (real part)	38.153660
Conductivity (S/m)	1.740236
Power Variation (%)	3.234772
Ambient Temperature	21.1
Liquid Temperature	21.2

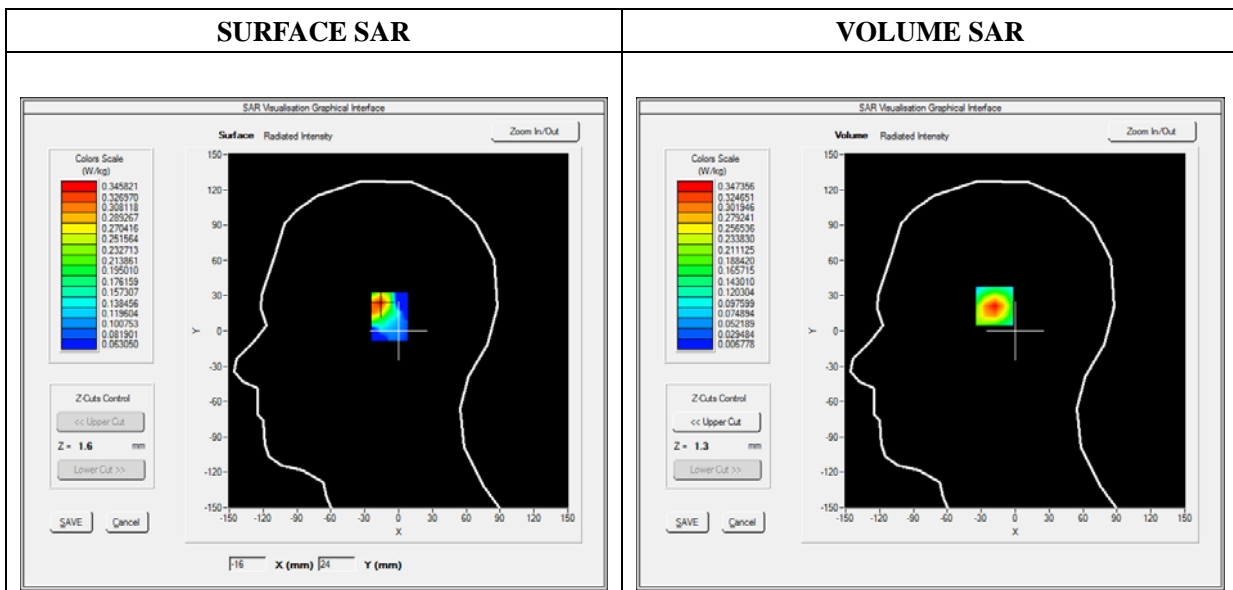

Maximum location: X=-17.00, Y=23.00

SAR Peak: 0.63 W/kg

SAR 10g (W/Kg)	0.153724
SAR 1g (W/Kg)	0.324689

Z (mm)	0.00	4.00	9.00	14.00	19.00
SAR (W/Kg)	0.6307	0.3474	0.1527	0.0654	0.0308

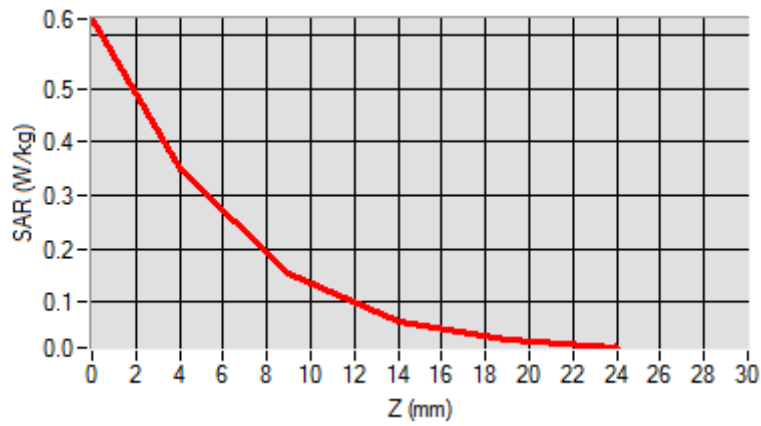

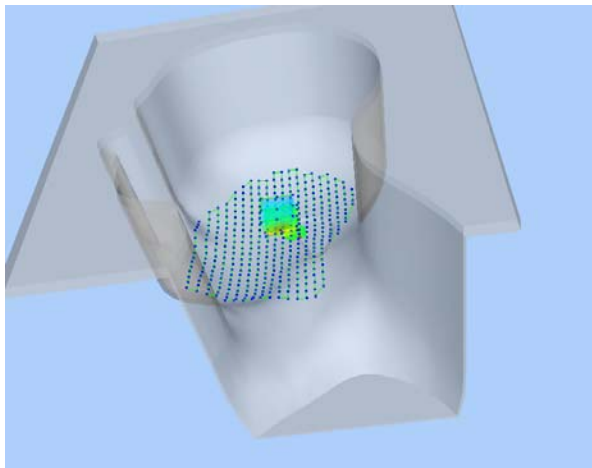
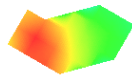
<p align="center">3D screen shot</p>	<p align="center">Hot spot position</p>
	

MEASUREMENT 141

Type: Phone measurement (Complete)

Date of measurement: 09/19/2019

Measurement duration: 12 minutes 3 seconds

E-field Probe: SSE2 - SN 45/15 EPGO280; ConvF: 2.28; Calibrated: 2019/07/08

A. Experimental conditions

Area Scan	sam_direct_droit2_surf8mm.txt
Phantom	Right head
Device Position	Cheek
Band	WiFi(5.2G)_802.11a
Channels	High
Signal	Duty Cycle: 1:1

B. SAR Measurement Results

Frequency (MHz)	5240.000000
Relative Permittivity (real part)	35.612911
Conductivity (S/m)	4.871483
Power Variation (%)	1.083921
Ambient Temperature	21.1
Liquid Temperature	21.2

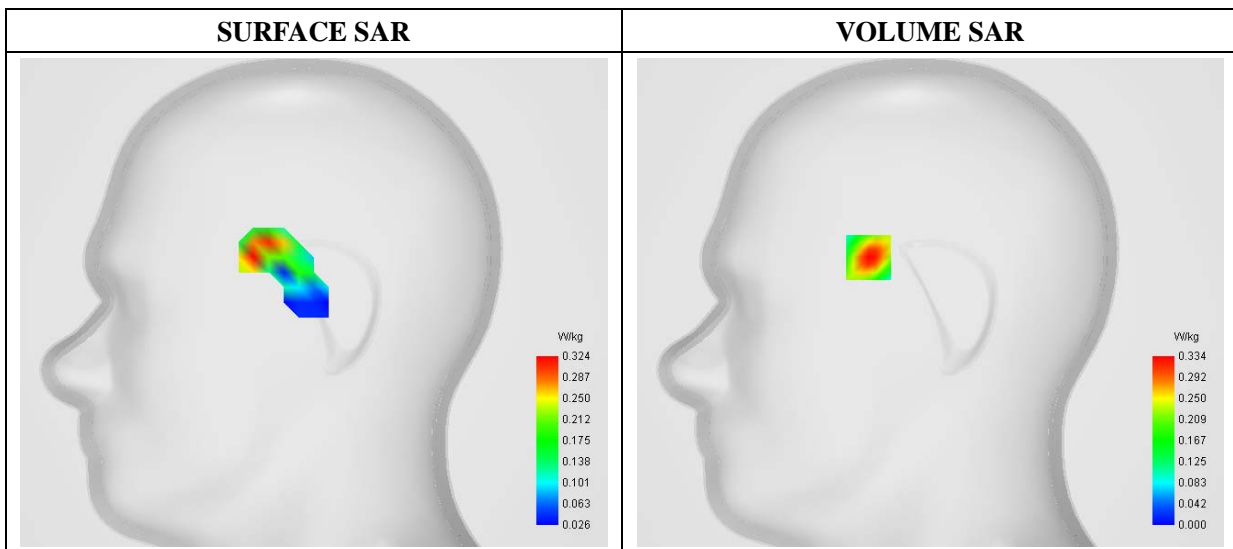

Maximum location: X=-33.00, Y=24.00

SAR 10g (W/Kg)	0.146803
SAR 1g (W/Kg)	0.349393

Z (mm)	0.00	2.00	4.00	6.00	8.00	10.00	12.00	14.00	16.00	18.00
SAR (W/Kg)	0.5866	0.3337	0.1745	0.0885	0.0480	0.0309	0.0258	0.0276	0.0401	0.0401

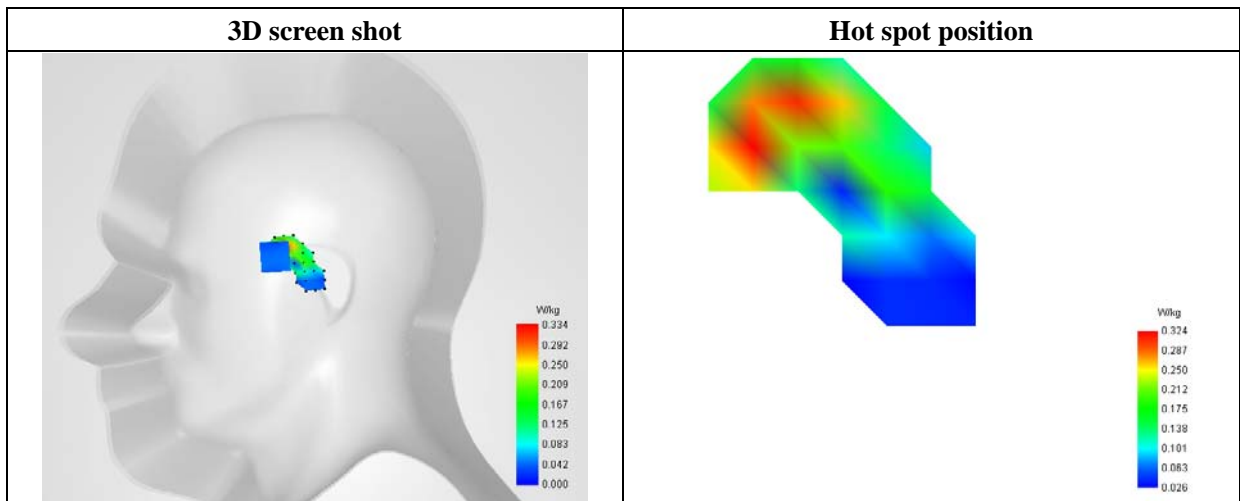
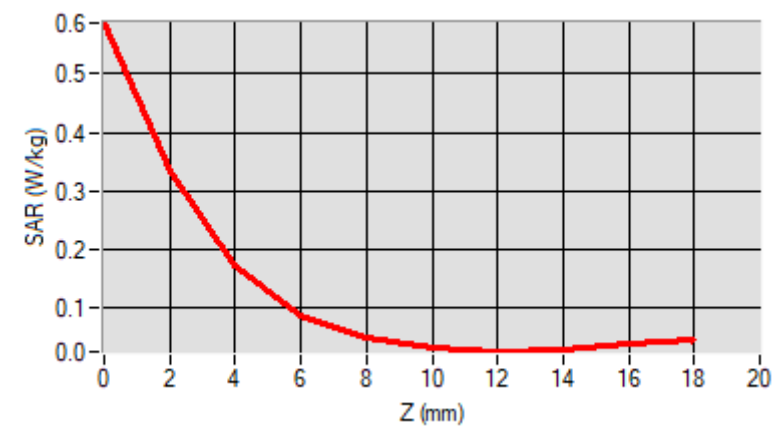

MEASUREMENT 147

Type: Phone measurement (Complete)

Date of measurement: 2019/09/19

Measurement duration: 12 minutes 3 seconds

E-field Probe: SSE2 - SN 45/15 EPGO280; ConvF: 2.23; Calibrated: 2019/07/08

A. Experimental conditions

Area Scan	sam_direct_droit2_surf8mm.txt
Phantom	Left head
Device Position	Cheek
Band	WiFi(5.3G)_802.11n-20
Channels	Low
Signal	Duty Cycle: 1:1

B. SAR Measurement Results

Frequency (MHz)	5270.000000
Relative Permittivity (real part)	35.620839
Conductivity (S/m)	4.740192
Power Variation (%)	0.463782
Ambient Temperature	22.0
Liquid Temperature	22.3

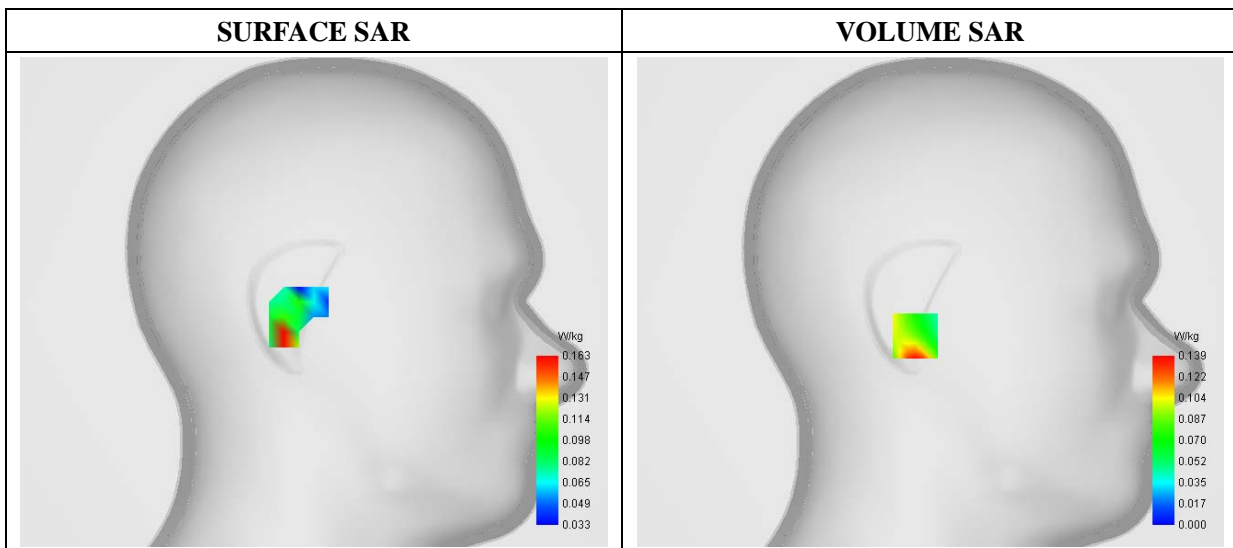

Maximum location: X=8.00, Y=-18.00

SAR 10g (W/Kg)	0.066032
SAR 1g (W/Kg)	0.137514

Z (mm)	0.00	2.00	4.00	6.00	8.00	10.00	12.00	14.00	16.00	18.00
SAR (W/Kg)	0.2807	0.1392	0.0563	0.0481	0.0383	0.0258	0.0318	0.0286	0.0254	0.0254

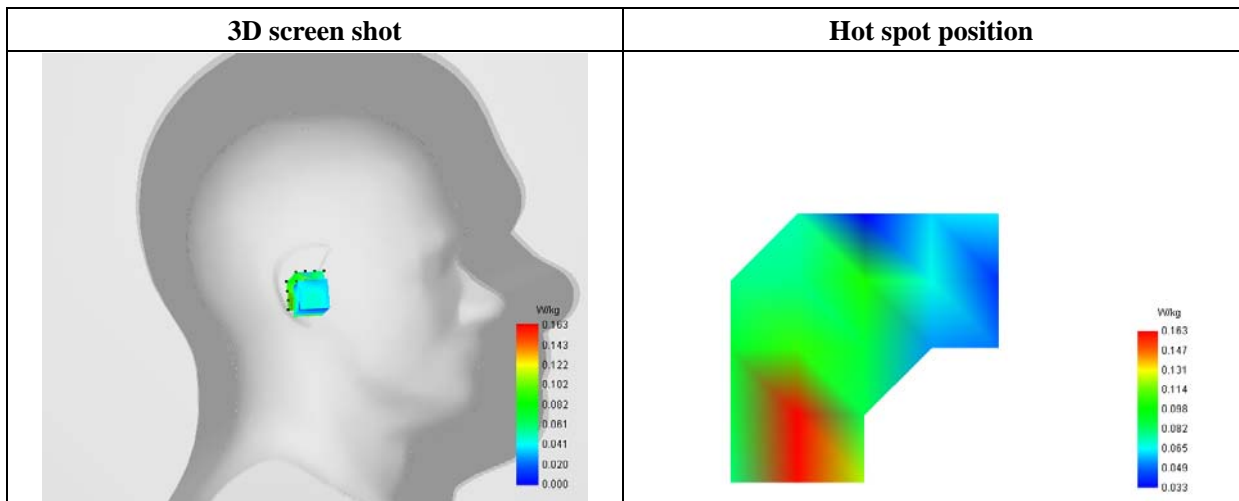
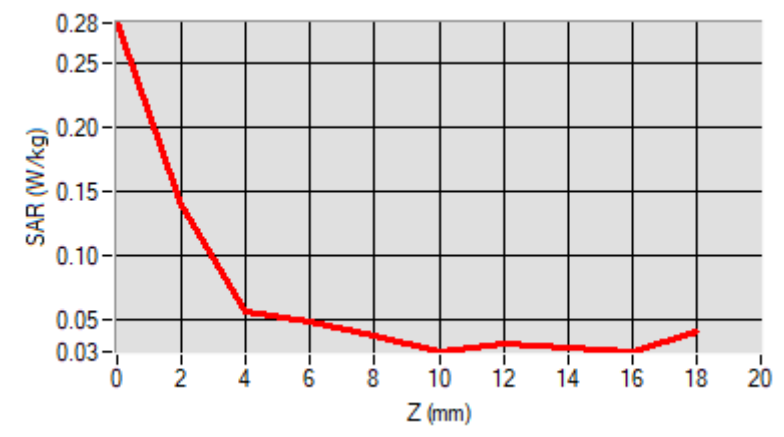

MEASUREMENT 151

Type: Phone measurement (Complete)

Date of measurement: 2019/09/19

Measurement duration: 12 minutes 3 seconds

E-field Probe: SSE2 - SN 45/15 EPGO280; ConvF: 2.37; Calibrated: 2019/07/08

A. Experimental conditions

Area Scan	sam_direct_droit2_surf8mm.txt
Phantom	Left head
Device Position	Cheek
Band	WiFi(5.6G)_802.11a
Channels	Low
Signal	Duty Cycle: 1:1

B. SAR Measurement Results

Frequency (MHz)	5500.000000
Relative Permittivity (real part)	35.301254
Conductivity (S/m)	5.210512
Power Variation (%)	0.848732
Ambient Temperature	22.0
Liquid Temperature	22.3

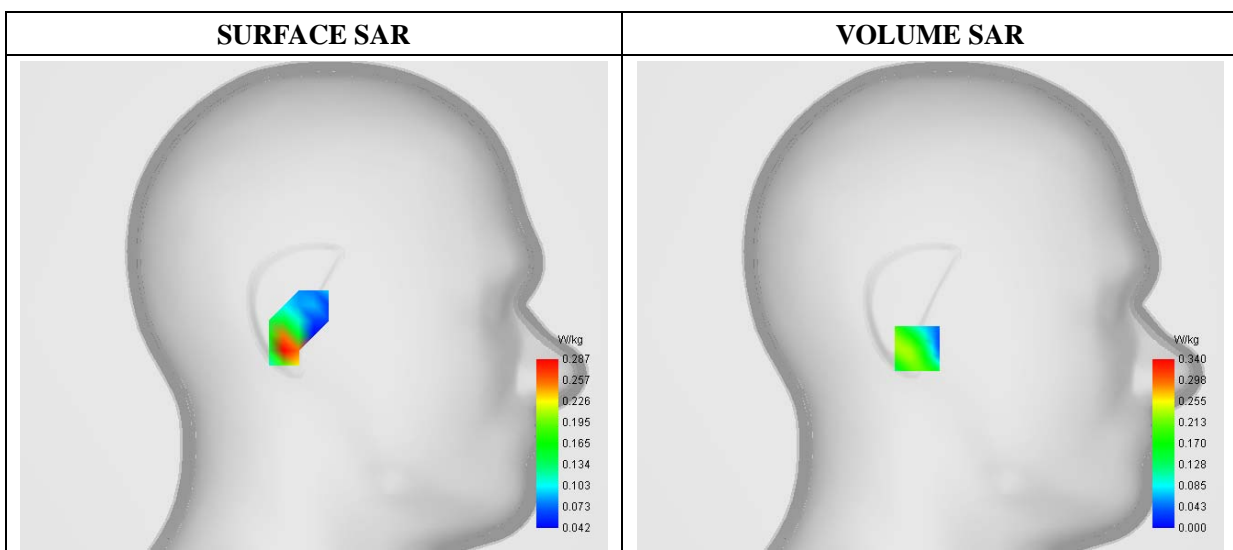

Maximum location: X=7.00, Y=-23.00

SAR 10g (W/Kg)	0.118537
SAR 1g (W/Kg)	0.305729

Z (mm)	0.00	2.00	4.00	6.00	8.00	10.00	12.00	14.00	16.00	18.00
SAR (W/Kg)	0.4985	0.2340	0.0623	0.0668	0.0401	0.0247	0.0327	0.0206	0.0323	0.0323

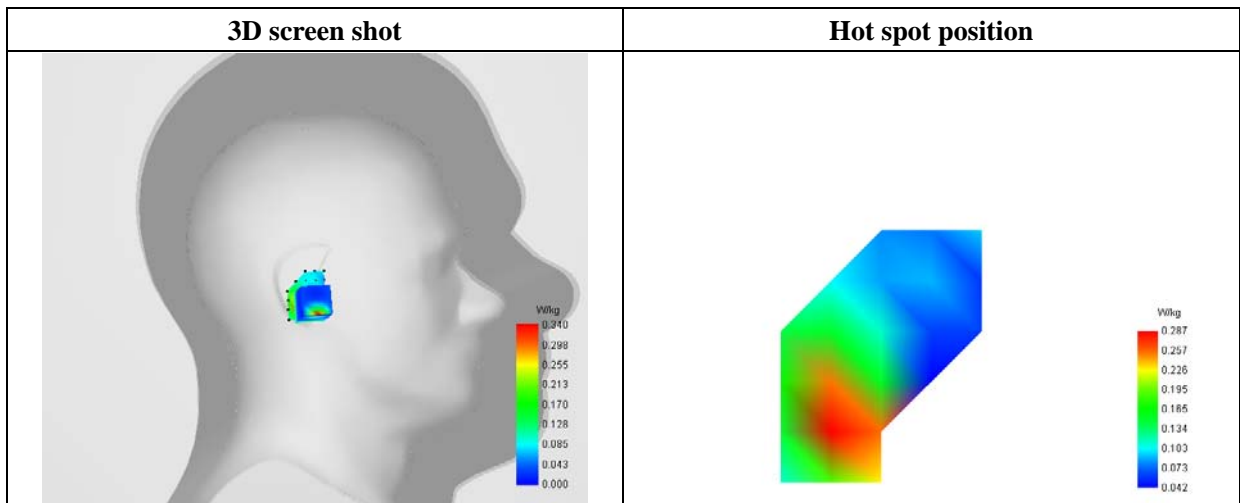
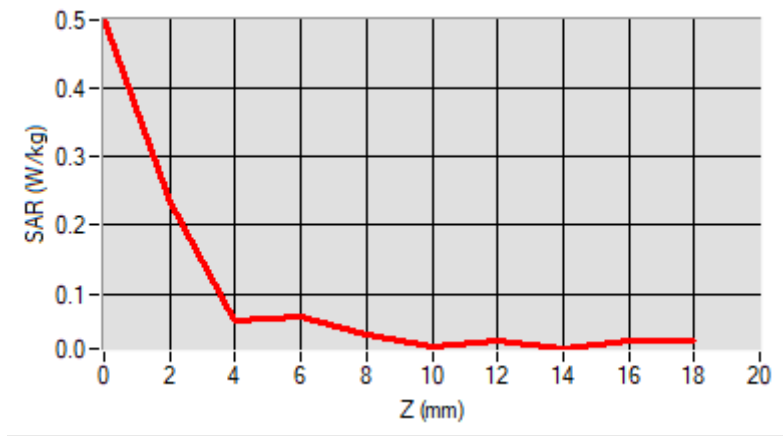

MEASUREMENT 153

Type: Phone measurement (Complete)

Date of measurement: 2019/09/19

Measurement duration: 12 minutes 3 seconds

E-field Probe: SSE2 - SN 45/15 EPGO280; ConvF: 2.44; Calibrated: 2017/09/18

A. Experimental conditions

Area Scan	sam_direct_droit2_surf8mm.txt
Phantom	Right head
Device Position	Cheek
Band	WiFi(5.8G)_802.11a
Channels	High
Signal	Duty Cycle: 1:1

B. SAR Measurement Results

Frequency (MHz)	5825.000000
Relative Permittivity (real part)	35.612911
Conductivity (S/m)	5.171483
Power Variation (%)	1.083921
Ambient Temperature	21.1
Liquid Temperature	21.2

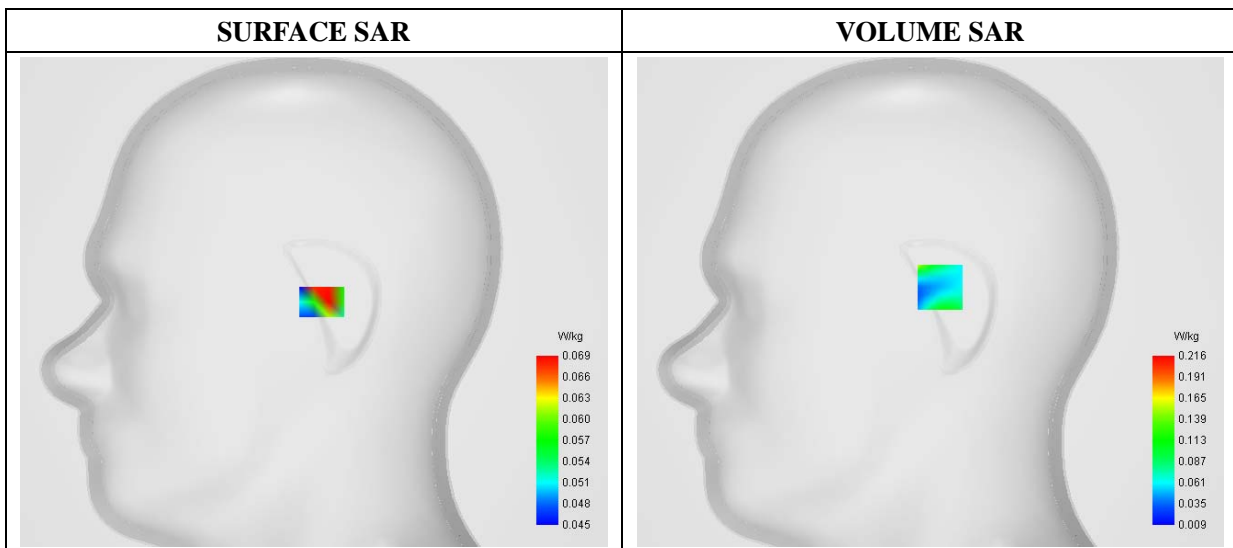

Maximum location: X=5.00, Y=8.00

SAR 10g (W/Kg)	0.065276
SAR 1g (W/Kg)	0.105084

Z (mm)	0.00	2.00	4.00	6.00	8.00	10.00	12.00	14.00	16.00	18.00
SAR (W/Kg)	0.3393	0.1630	0.0485	0.0333	0.0176	0.0115	0.0160	0.0182	0.0405	0.0405

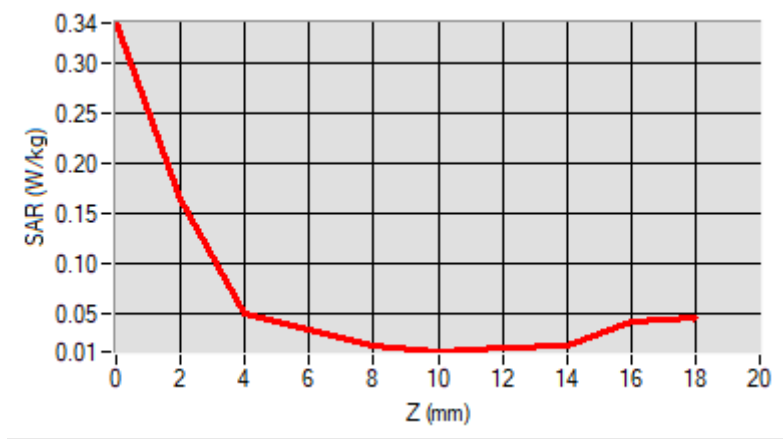

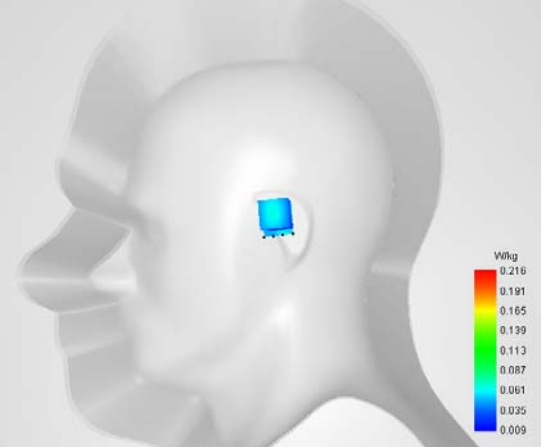
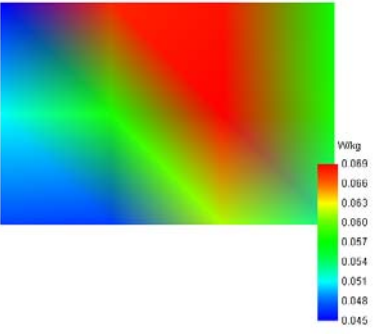
3D screen shot	Hot spot position
	

MEASUREMENT 157

Type: Phone measurement (Complete)

Date of measurement: 09/16/2019

Measurement duration: 12 minutes 3 seconds

E-field Probe: SSE5 - SN 09/13 EP168; ConvF: 7.13; Calibrated: 05/22/2019

A. Experimental conditions

Area Scan	sam_direct_droit2_surf8mm.txt
Phantom	Flat Plane
Device Position	Back(Body-worn)
Band	GSM850
Channels	Low
Signal	TDMA (Crest factor: 8.0)

B. SAR Measurement Results

Frequency (MHz)	824.200000
Relative Permittivity (real part)	54.851214
Conductivity (S/m)	0.951454
Power Variation (%)	0.901472
Ambient Temperature	21.1
Liquid Temperature	21.3

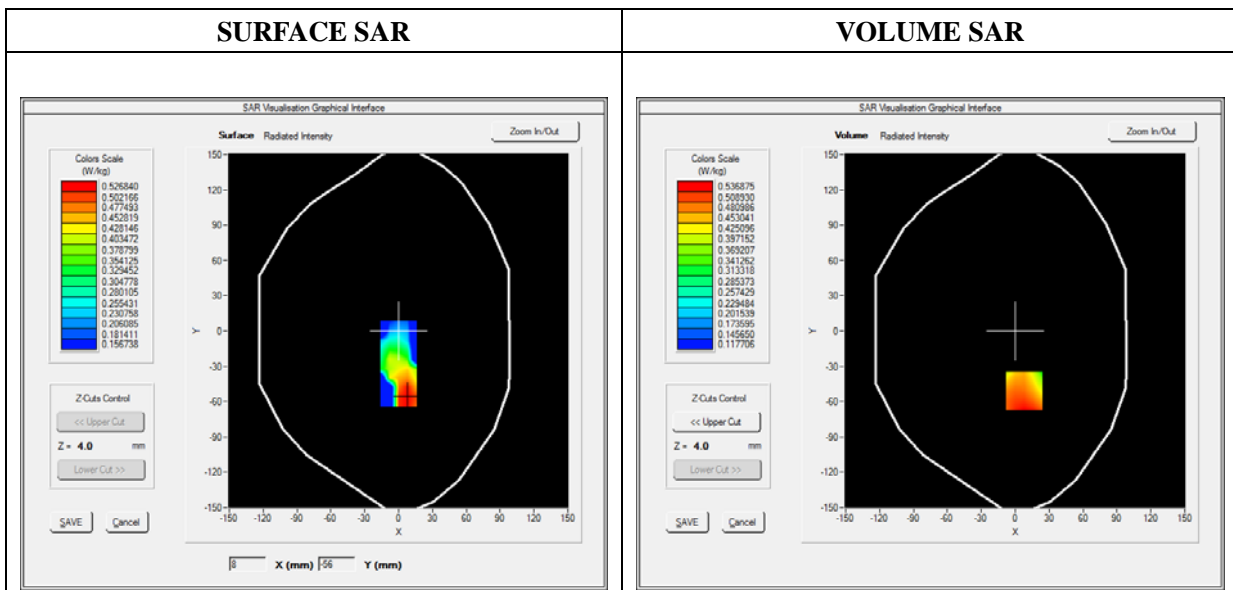



Maximum location: X=8.00, Y=-51.00

SAR Peak: 0.69 W/kg

SAR 10g (W/Kg)	0.384582
SAR 1g (W/Kg)	0.508035

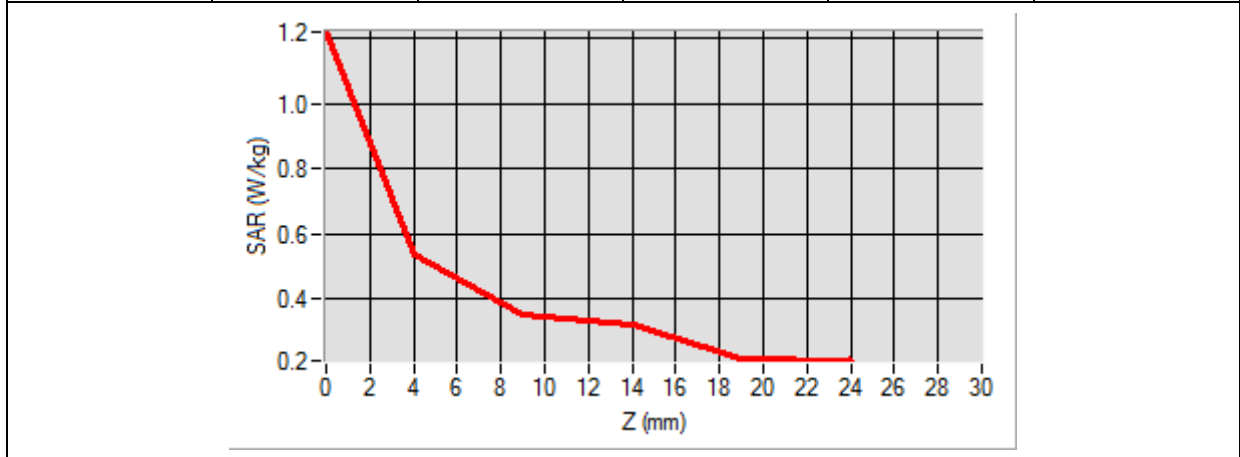
Z (mm)	0.00	4.00	9.00	14.00	19.00
SAR (W/Kg)	1.2192	0.5369	0.3529	0.3238	0.2155

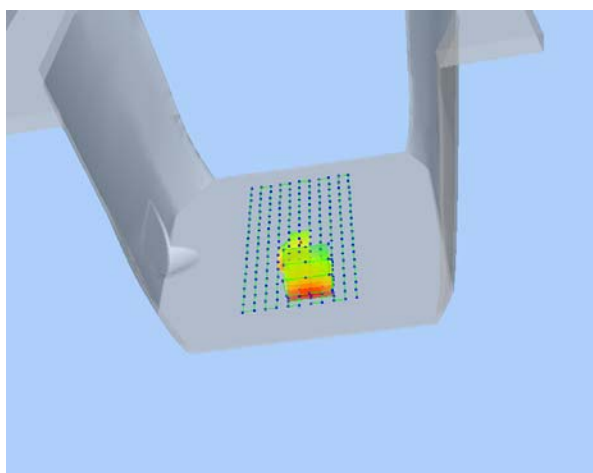

<p>3D screen shot</p>	<p>Hot spot position</p>
	

MEASUREMENT 159

Type: Phone measurement (Complete)

Date of measurement: 09/17/2019

Measurement duration: 12 minutes 3 seconds

E-field Probe: SSE5 - SN 09/13 EP168; ConvF: 6.55; Calibrated: 05/22/2019

A. Experimental conditions

Area Scan	sam_direct_droit2_surf8mm.txt
Phantom	Flat Plane
Device Position	Back(Body-worn)
Band	GSM1900
Channels	High
Signal	TDMA (Crest factor: 8.0)

B. SAR Measurement Results

Frequency (MHz)	1909.800000
Relative Permittivity (real part)	52.420415
Conductivity (S/m)	1.501966
Power Variation (%)	1.474622
Ambient Temperature	21.1
Liquid Temperature	21.3

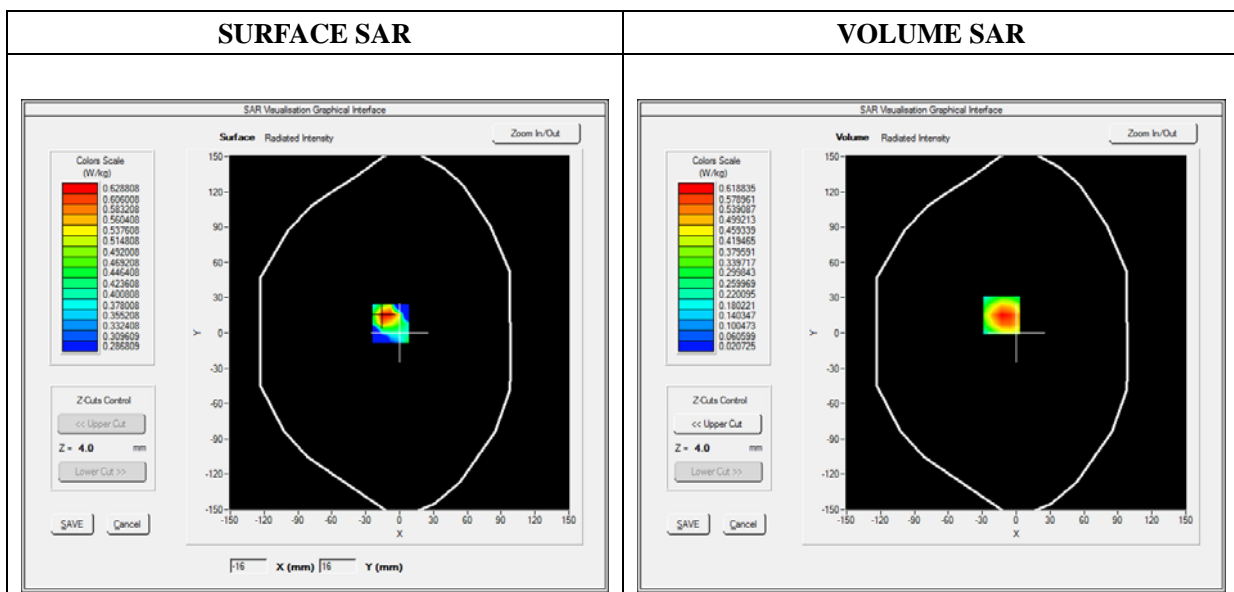

Maximum location: X=-13.00, Y=15.00

SAR Peak: 1.02 W/kg

SAR 10g (W/Kg)	0.313016
SAR 1g (W/Kg)	0.587605

Z (mm)	0.00	4.00	9.00	14.00	19.00
SAR (W/Kg)	1.0039	0.6188	0.3267	0.1733	0.0974

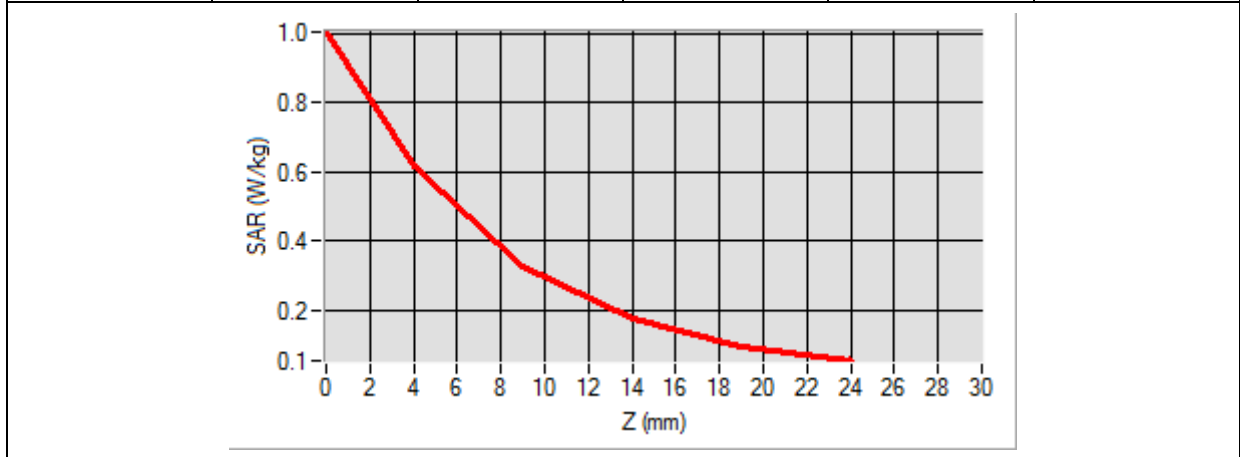

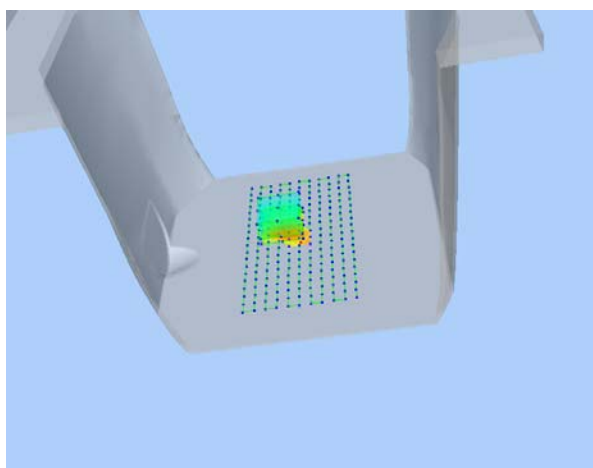
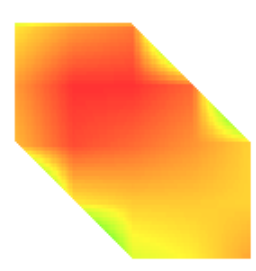
<p>3D screen shot</p>	<p>Hot spot position</p>
	

MEASUREMENT 235

Type: Phone measurement (Complete)

Date of measurement: 09/16/2019

Measurement duration: 12 minutes 3 seconds

E-field Probe: SSE5 - SN 09/13 EP168; ConvF: 7.13; Calibrated: 05/22/2019

A. Experimental conditions

Area Scan	sam_direct_droit2_surf8mm.txt
Phantom	Flat plane
Device Position	Back
Band	GPRS850_4TX
Channels	Low
Signal	Duty Cycle: 1:2

B. SAR Measurement Results

Frequency (MHz)	824.200000
Relative Permittivity (real part)	54.851214
Conductivity (S/m)	0.951454
Power Variation (%)	0.901472
Ambient Temperature	21.1
Liquid Temperature	21.3

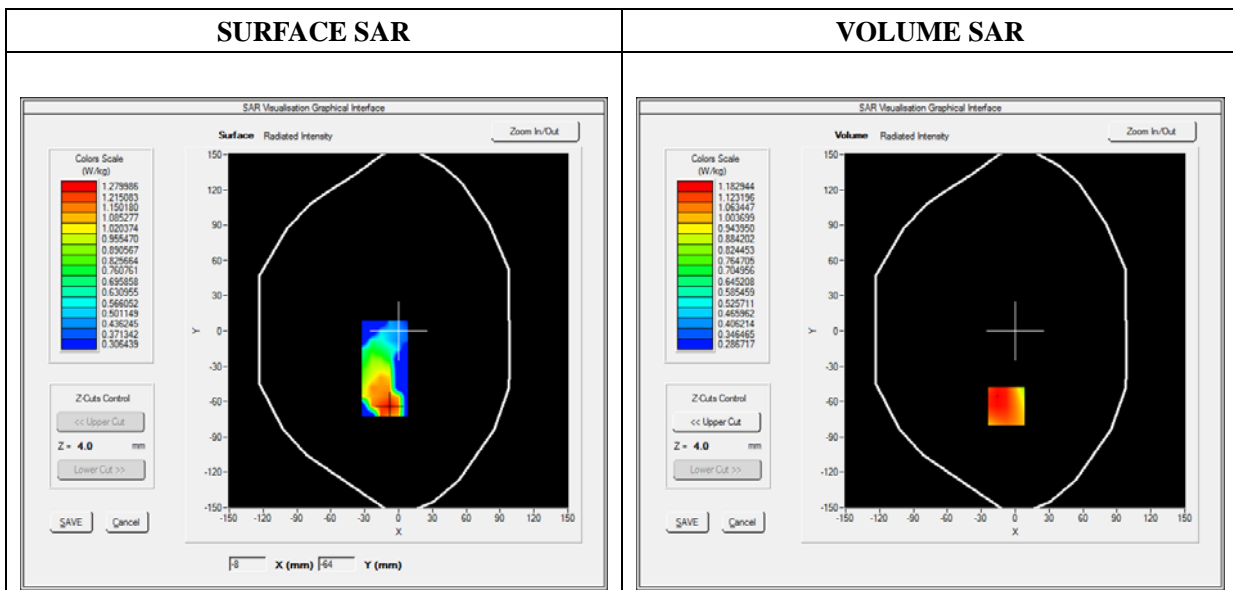

Maximum location: X=-8.00, Y=-64.00

SAR Peak: 1.47 W/kg

SAR 10g (W/Kg)	0.892662
SAR 1g (W/Kg)	1.164996

Z (mm)	0.00	4.00	9.00	14.00	19.00
SAR (W/Kg)	2.1369	1.1829	0.8549	0.7388	0.5327

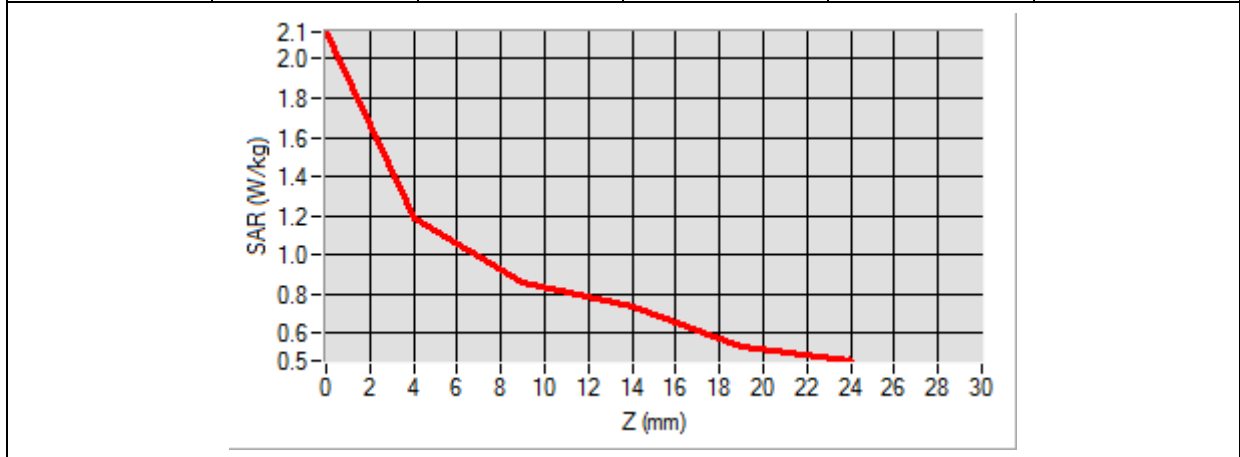

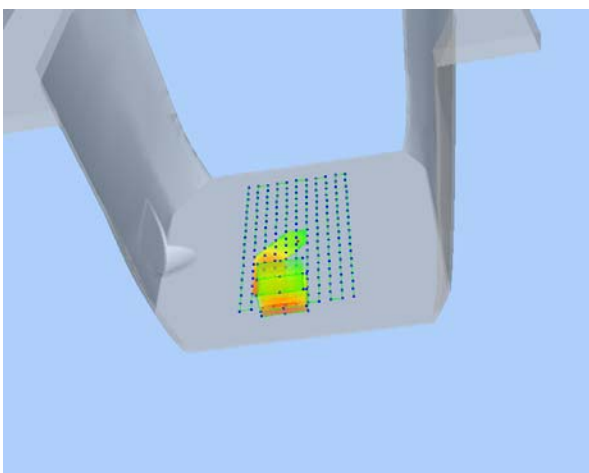
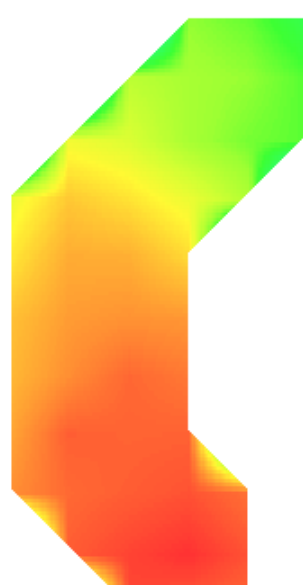
3D screen shot	Hot spot position
	

MEASUREMENT 245

Type: Phone measurement (Complete)

Date of measurement: 09/17/2019

Measurement duration: 12 minutes 3 seconds

E-field Probe: SSE5 - SN 09/13 EP168; ConvF: 6.55; Calibrated: 05/22/2019

A. Experimental conditions

Area Scan	sam_direct_droit2_surf8mm.txt
Phantom	Flat plane
Device Position	Back
Band	GPRS1900_2TX
Channels	Low
Signal	Duty Cycle: 1:4

B. SAR Measurement Results

Frequency (MHz)	1850.200000
Relative Permittivity (real part)	52.420415
Conductivity (S/m)	1.501966
Power Variation (%)	2.483762
Ambient Temperature	21.1
Liquid Temperature	21.3

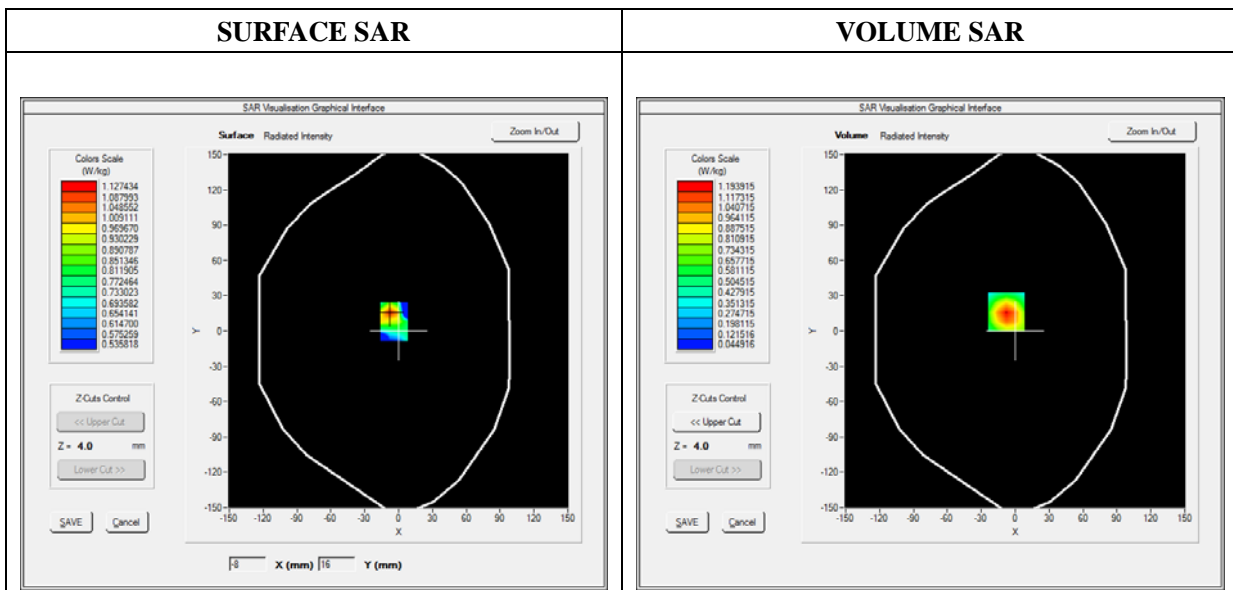



Maximum location: X=-8.00, Y=16.00

SAR Peak: 2.08 W/kg

SAR 10g (W/Kg)	0.569631
SAR 1g (W/Kg)	1.126465

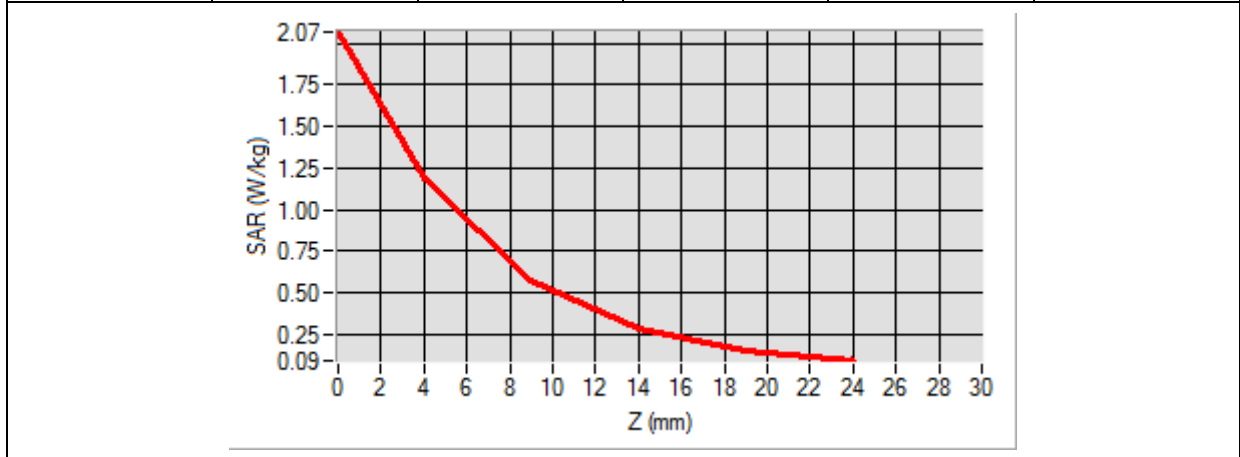
Z (mm)	0.00	4.00	9.00	14.00	19.00
SAR (W/Kg)	2.0667	1.1939	0.5742	0.2816	0.1567

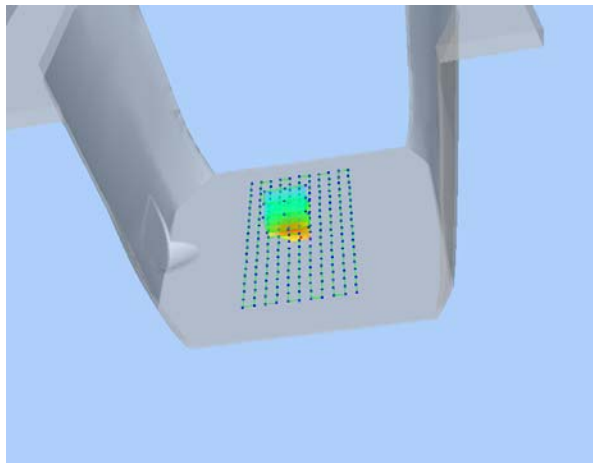

3D screen shot	Hot spot position
	

MEASUREMENT 257

Type: Phone measurement (Complete)

Date of measurement: 09/17/2019

Measurement duration: 12 minutes 3 seconds

E-field Probe: SSE5 - SN 09/13 EP168; ConvF: 6.55; Calibrated: 05/22/2019

A. Experimental conditions

Area Scan	sam_direct_droit2_surf8mm.txt
Phantom	Flat Plane
Device Position	Back
Band	WCDMA1900_RMC
Channels	Middle
Signal	Duty Cycle 1:1

B. SAR Measurement Results

Frequency (MHz)	1880.000000
Relative Permittivity (real part)	52.420415
Conductivity (S/m)	1.501966
Power Variation (%)	1.163283
Ambient Temperature	21.1
Liquid Temperature	21.3

