

TEST REPORT

Reference No...... : WTX19X08058778W-12
FCC ID : 2A13KCS22XA
Applicant..... : Cyrus Technology GmbH
Address..... : Hergelsbendenstrasse 49, D-52080 Aachen, Germany
Manufacturer : Cyrus Technology GmbH
Address..... : Hergelsbendenstrasse 49, D-52080 Aachen, Germany
Product..... : Rugged Phone
Model(s) : CS22XA
Brand Name..... : CYRUS
Standards..... : FCC CFR47 Part 90
Date of Receipt sample : 2019-08-23
Date of Test : 2019-08-23 to 2019-09-24
Date of Issue..... : 2019-09-24
Test Result..... : **Pass**

Remarks:

The results shown in this test report refer only to the sample(s) tested, this test report cannot be reproduced, except in full, without prior written permission of the company. The report would be invalid without specific stamp of test institute and the signatures of compiler and approver.

Prepared By:

Waltek Services (Shenzhen) Co., Ltd.

Address: 1/F., Fukangtai Building, West Baima Road, Songgang Street, Baoan District, Shenzhen, Guangdong, China

Tel :+86-755-83551033

Fax:+86-755-83552400

Compiled by:

Ford Wang

Ford Wang / Project Engineer

Approved by:



Philo Zhong

Philo Zhong / Manager

2 Laboratories Introduction

Waltek Services (Shenzhen) Co., Ltd is a professional third-party testing and certification laboratory with multi-year product testing and certification experience, established strictly in accordance with ISO/IEC 17025 requirements, and accredited by ILAC (International Laboratory Accreditation Cooperation) member. A2LA (American Association for Laboratory Accreditation, the certification number is 4243.01) of USA, CNAS (China National Accreditation Service for Conformity Assessment, the registration number is L3110) of China. Meanwhile, Waltek has got recognition as registration and accreditation laboratory from EMSD (Electrical and Mechanical Services Department), and American Energy star, FCC (The Federal Communications Commission), CEC (California energy efficiency), ISED (Innovation, Science and Economic Development Canada). It's the strategic partner and data recognition laboratory of international authoritative organizations, such as Intertek (ETL-SEMKO), TÜV Rheinland, TÜV SÜD, etc.



Waltek Services (Shenzhen) Co., Ltd is one of the largest and the most comprehensive third party testing laboratory in China. Our test capability covered four large fields: safety test. Electro Magnetic Compatibility (EMC), and energy performance, wireless radio. As a professional, comprehensive, justice international test organization, we still keep the scientific and rigorous work attitude to help each client satisfy the international standards and assist their product enter into globe market smoothly.

Test Facility:**A. Accreditations for Conformity Assessment (International)**

Country/Region	Scope Covered By	Scope	Note
USA	ISO/IEC 17025	FCC ID \ DOC \ VOC	1
Canada		IC ID \ VOC	2
Japan		MIC-T \ MIC-R	-
Europe		EMCD \ RED	-
Taiwan		NCC	-
Hong Kong		OFCA	-
Australia		RCM	-
India		WPC	-
Thailand		NTC	-
Singapore		IDA	-
Note: 1. FCC Designation No.: CN1201. Test Firm Registration No.: 523476. 2. ISED Canada Registration No.: 7760A			

B. TCBs and Notify Bodies Recognized Testing Laboratory.

Recognized Testing Laboratory of ...	Notify body number
TUV Rheinland	Optional.
Intertek	
TUV SUD	
SGS	
Phoenix Testlab GmbH	0700
Element Materials Technology Warwick Ltd	0891
Timco Engineering, Inc.	1177
Eurofins Product Service GmbH	0681

3 Contents

	Page
1 COVER PAGE	1
2 LABORATORIES INTRODUCTION	2
3 CONTENTS	4
4 REVISION HISTORY	5
5 GENERAL INFORMATION	6
5.1 GENERAL DESCRIPTION OF E.U.T.	6
5.2 DETAILS OF E.U.T.	6
5.3 TEST MODE	7
6 TEST SUMMARY	8
7 EQUIPMENT USED DURING TEST	9
7.1 EQUIPMENTS LIST	9
7.2 MEASUREMENT UNCERTAINTY	10
7.3 TEST EQUIPMENT CALIBRATION	10
8 RF OUTPUT POWER	11
8.1 EUT OPERATION.....	11
8.2 TEST PROCEDURE	11
8.3 TEST RESULT	12
9 PEAK-TO-AVERAGE RATIO	15
9.1 EUT OPERATION.....	15
9.2 TEST PROCEDURE	15
9.3 TEST RESULT	15
10 BANDWIDTH	16
10.1 EUT OPERATION.....	16
10.2 TEST PROCEDURE.....	16
10.3 TEST RESULT	17
11 SPURIOUS EMISSIONS AT ANTENNA TERMINALS	18
11.1 EUT OPERATION.....	18
11.2 TEST PROCEDURE.....	18
11.3 TEST RESULT	18
12 SPURIOUS RADIATED EMISSIONS	19
12.1 EUT OPERATION.....	19
12.2 TEST SETUP	19
12.3 SPECTRUM ANALYZER SETUP	20
12.4 TEST PROCEDURE.....	21
12.5 SUMMARY OF TEST RESULTS	22
13 BAND EDGE MEASUREMENT	23
13.1 EUT OPERATION.....	23
13.2 TEST PROCEDURE.....	23
13.3 TEST RESULT	24
14 FREQUENCY STABILITY	25
14.1 EUT OPERATION.....	25
14.2 TEST PROCEDURE.....	25
14.3 TEST RESULT	26

4 Revision History

Test report No.	Date of Receipt sample	Date of Test	Date of Issue	Purpose	Comment	Approved
WTX19X08058 778W-12	2019-08-23	2019-08-23 to 2019-09- 24	2019-09-25	original	-	Valid

5 General Information

5.1 General Description of E.U.T.

Product:	Rugged Phone
Model(s):	CS22XA
Model Description:	N/A
LTE Band(s):	FDD Band 26
Hardware Version:	L915-MB-V1.1
Software Version:	CS22XA_ROW_1.0.2
Storage Location:	Internal Storage
Note:	/

5.2 Details of E.U.T.

Operation Frequency:	LTE Band 26: 814-824MHz
Max. RF output power:	LTE Band 26: 23.41dBm
Type of Modulation:	LTE: QPSK, 16QAM
Antenna installation:	LTE: internal permanent antenna
Antenna Gain:	LTE Band 26 1.25dBi
Ratings:	/
Adapter1:	MKC-0502000SU INPUT: AC100-240V, 50/60Hz, 0.4A; Output: DC 5V, 2000mA
Type of Emission:	LTE Band 26- 1.4MHz: 1M08G7D(QPSK), 1M08W7D(16QAM) LTE Band 26- 22 3MHz: 2M68G7D(QPSK), 2M68W7D(16QAM) LTE Band 26- 22 5MHz: 4M48G7D(QPSK), 4M49W7D(16QAM) LTE Band 26- 22 10 MHz: 8M95G7D(QPSK), 8M94W7D(16QAM)

5.3 Test Mode

All test mode(s) and condition(s) mentioned were considered and evaluated respectively by performing full tests, the worst data were recorded and reported.

Support Band	Test Mode BW(MHz)	Channel Frequency	Channel Number
LTE Band 26 UL: 814-824MHz	1.4	814.7 MHz	26697
		819.0 MHz	26740
		823.3 MHz	26783
	3	815.5 MHz	26705
		819.0 MHz	26740
		822.5 MHz	26775
	5	816.5 MHz	26715
		819.0 MHz	26740
		821.5 MHz	26765
	10	819.0 MHz	26740
Remark: All mode(s) were tested and the worst data was recorded.			

6 Test Summary

Test Items	Test Requirement	Result
RF Output Power	2.1046 90.635	PASS
Peak-to-Average Ratio	24.232 (d) 27.50(d)	PASS
Bandwidth	2.1049 90.691	PASS
Spurious Emissions at Antenna Terminal	2.1051 90.691	PASS
Field Strength of Spurious Radiation	2.1053 90.691	PASS
Out of band emission	90.691	PASS
Frequency Stability	2.1055 90.231	PASS
Maximum Permissible Exposure (SAR)	1.1307 2.1093	PASS

7 Equipment Used during Test

7.1 Equipments List

Conducted Emissions Test Site 1#						
Item	Equipment	Manufacturer	Model No.	Serial No.	Last Calibration Date	Calibration Due Date
1.	EMI Test Receiver	R&S	ESCI	100947	2018-09-12	2019-09-11
2.	LISN	R&S	ENV216	101215	2018-09-12	2019-09-11
3.	Cable	Top	TYPE16(3.5M)	-	2018-09-12	2019-09-11
Conducted Emissions Test Site 2#						
Item	Equipment	Manufacturer	Model No.	Serial No.	Last Calibration Date	Calibration Due Date
1.	EMI Test Receiver	R&S	ESCI	101155	2018-09-12	2019-09-11
2.	LISN	SCHWARZBECK	NSLK 8128	8128-289	2018-09-12	2019-09-11
3.	Limiter	York	MTS-IMP-136	261115-001-0024	2018-09-12	2019-09-11
4.	Cable	LARGE	RF300	-	2018-09-12	2019-09-11
3m Semi-anechoic Chamber for Radiation Emissions Test site 1#						
Item	Equipment	Manufacturer	Model No.	Serial No.	Last Calibration Date	Calibration Due Date
1	Spectrum Analyzer	R&S	FSP	100091	2019-04-29	2020-04-28
2	Active Loop Antenna	Beijing Dazhi	ZN30900A	-	2019-04-09	2020-04-08
3	Trilog Broadband Antenna	SCHWARZBECK	VULB9163	336	2019-04-09	2020-04-08
4	Coaxial Cable (below 1GHz)	Top	TYPE16(13M)	-	2018-09-12	2019-09-11
5	Broad-band Horn Antenna	SCHWARZBECK	BBHA 9120 D	667	2019-04-09	2020-04-08
6	Broad-band Horn Antenna	SCHWARZBECK	BBHA 9170	335	2019-04-09	2020-04-08
7	Broadband Preamplifier	COMPLIANCE DIRECTION	PAP-1G18	2004	2019-04-13	2020-04-12
8	Coaxial Cable (above 1GHz)	Top	1GHz-25GHz	EW02014-7	2019-04-13	2020-04-12
9	Signal Generator	R&S	SMR20	100046	2018-09-12	2019-09-11
10	Smart Antenna	SCHWARZBECK	HA08	-	2019-04-09	2020-04-08
3m Semi-anechoic Chamber for Radiation Emissions Test site 2#						
Item	Equipment	Manufacturer	Model No.	Serial No	Last Calibration Date	Calibration Due Date
1	Test Receiver	R&S	ESCI	101296	2019-04-13	2020-04-12
2	Trilog Broadband Antenna	SCHWARZBECK	VULB9160	9160-3325	2019-04-09	2020-04-08

3	Amplifier	Compliance pirection systems inc	PAP-0203	22024	2019-04-13	2020-04-12
4	Cable	HUBER+SUHNER	CBL2	525178	2019-04-13	2020-04-12
RF Conducted Testing						
Item	Equipment	Manufacturer	Model No.	Serial No.	Last Calibration Date	Calibration Due Date
1.	EMC Analyzer (9k~26.5GHz)	Agilent	E7405A	MY45114943	2018-09-12	2019-09-11
2.	Spectrum Analyzer	Agilent	N9020A	MY49100060	2018-09-12	2019-09-11
3.	Universal Radio Communication Tester	R&S	CMW 500	127818	2018-04-13	2019-04-12
4	Signal Analyzer (9k~26.5GHz)	Agilent	N9010A	MY50520207	2018-09-12	2019-09-11

7.2 Measurement Uncertainty

Parameter	Uncertainty
Conducted Emission	± 3.64 dB(AC mains 150KHz~30MHz)
Radiated Spurious Emissions	± 5.08 dB (Bilog antenna 30M~1000MHz)
	± 5.47 dB (Horn antenna 1000M~25000MHz)
Radio Frequency	± 1 x 10 ⁻⁷ Hz
RF Power	± 0.42 dB
RF Power Density	± 0.7dB
Conducted Spurious Emissions	± 2.76 dB (9kHz~26500MHz)
Confidence interval: 95%. Confidence factor:k=2	

7.3 Test Equipment Calibration

All the test equipments used are valid and calibrated by CEPREI Certification Body that address is No.110 Dongguan Zhuang RD. Guangzhou, P.R.China.

8 RF OUTPUT POWER

Test Requirement:	FCC Part 2.1046, 90.635
Test Method:	TIA/EIA-603-E:2016 KDB 971168 D01 Power Meas License Digital Systems v03
Test Mode:	TX transmitting

8.1 EUT Operation

Operating Environment :

Temperature:	22.5 °C
Humidity:	52.1 % RH
Atmospheric Pressure:	101.2kPa

8.2 Test Procedure

Conducted method:

The RF output of the transmitter was connected to the wireless test set and the spectrum analyzer through sufficient attenuation.

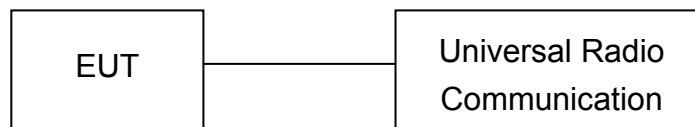

Radiated method:

1. The setup of EUT is according with per TIA/EIA Standard 603E:2016.
2. The measurement antenna was placed at a distance of 3 meters from the EUT. During the tests, the antenna height and polarization as well as EUT azimuth were varied in order to identify the maximum level of emissions from the EUT. The test was performed by placing the EUT on 3-orthogonal axis.
3. The frequency range up to tenth harmonic of the fundamental frequency was investigated.
4. Remove the EUT and replace it with substitution antenna. A signal generator was connected to the substitution antenna by a non-radiating cable. The absolute levels of the spurious emissions were measured by the substitution.

8.3 Test Result

Conducted Power

Please refer to Appendix A

Test result: Pass

ERP

LTE Band 26

Remark: (Uplink: 814-824MHz is for FCC Part 90)

Frequency (MHz)	Receiver Reading (dBμV)	Turn table Angle Degree	RX Antenna		Substituted			Absolute Level (dBm)	Result	
			Height (m)	Polar (H/V)	SG Level (dBm)	Cable (dB)	Antenna Gain (dB)		Limit (dBm)	Margin (dB)
LTE Band 26 Channel 26697 – 1.4MHz – QPSK										
814.70	71.52	141	1.5	H	5.95	0.30	9.40	15.05	38.45	-23.4
814.70	77.65	25	1.5	V	10.52	0.30	9.40	19.62	38.45	-18.83
LTE Band 26 Channel 26740 – 1.4MHz – QPSK										
819.00	70.35	168	1.5	H	6.05	0.30	9.40	15.15	38.45	-23.3
819.00	76.78	179	1.5	V	10.79	0.30	9.40	19.89	38.45	-18.56
LTE Band 26 Channel 26783 – 1.4MHz – QPSK										
823.30	70.65	55	1.5	H	5.86	0.30	9.40	14.96	38.45	-23.49
823.30	75.45	214	1.5	V	10.16	0.30	9.40	19.26	38.45	-19.19
LTE Band 26 Channel 26697 – 1.4MHz – 16QAM										
814.70	71.15	193	1.5	H	7.52	0.30	9.40	16.62	38.45	-21.83
814.70	77.41	215	1.5	V	9.78	0.30	9.40	18.88	38.45	-19.57
LTE Band 26 Channel 26740 – 1.4MHz – 16QAM										
819.00	70.32	157	1.5	H	7.25	0.30	9.40	16.35	38.45	-22.1
819.00	77.96	39	1.5	V	9.36	0.30	9.40	18.46	38.45	-19.99
LTE Band 26 Channel 26783 – 1.4MHz – 16QAM										
823.30	70.18	87	1.5	H	6.59	0.30	9.40	15.69	38.45	-22.76
823.30	77.31	154	1.5	V	9.72	0.30	9.40	18.82	38.45	-19.63

Frequency	Receiver Reading	Turn table Angle	RX Antenna		Substituted			Absolute Level	Result	
			Height	Polar	SG Level	Cable	Antenna Gain		Limit	Margin
(MHz)	(dBμV)	Degree	(m)	(H/V)	(dBm)	(dB)	(dB)	(dBm)	(dBm)	(dB)
LTE Band 26 Channel 26705 – 3MHz – QPSK										
815.50	71.18	232	1.5	H	5.36	0.30	9.40	14.46	38.45	-23.99
815.50	76.52	142	1.5	V	10.17	0.30	9.40	19.27	38.45	-19.18
LTE Band 26 Channel 26740– 3MHz – QPSK										
819.00	70.11	239	1.5	H	5.94	0.30	9.40	15.04	38.45	-23.41
819.00	77.78	244	1.5	V	10.01	0.30	9.40	19.11	38.45	-19.34
LTE Band 26 Channel 26775 – 3MHz – QPSK										
822.50	70.61	176	1.5	H	5.11	0.30	9.40	14.21	38.45	-24.24
822.50	77.43	169	1.5	V	10.93	0.30	9.40	20.03	38.45	-18.42
LTE Band 26 Channel 26705 – 3MHz – 16QAM										
815.50	70.52	214	1.5	H	6.11	0.30	9.40	15.21	38.45	-23.24
815.50	76.39	132	1.5	V	11.01	0.30	9.40	20.11	38.45	-18.34
LTE Band 26 Channel 26740 – 3MHz – 16QAM										
819.00	71.14	198	1.5	H	6.14	0.30	9.40	15.24	38.45	-23.21
819.00	75.63	155	1.5	V	11.05	0.30	9.40	20.15	38.45	-18.3
LTE Band 26 Channel 26775 – 3MHz – 16QAM										
822.50	70.52	174	1.5	H	6.45	0.30	9.40	15.55	38.45	-22.9
822.50	76.45	131	1.5	V	11.01	0.30	9.40	20.11	38.45	-18.34

Frequency	Receiver Reading	Turn table Angle	RX Antenna		Substituted			Absolute Level	Result	
			Height	Polar	SG Level	Cable	Antenna Gain		Limit	Margin
(MHz)	(dBμV)	Degree	(m)	(H/V)	(dBm)	(dB)	(dB)	(dBm)	(dBm)	(dB)
LTE Band 26 Channel 26715 – 5MHz – QPSK										
816.50	72.05	211	1.5	H	6.87	0.30	9.40	15.97	38.45	-22.48
816.50	77.56	205	1.5	V	11.10	0.30	9.40	20.2	38.45	-18.25
LTE Band 26 Channel 26740 – 5MHz – QPSK										
819.00	71.41	175	1.5	H	6.82	0.30	9.40	15.92	38.45	-22.53
819.00	77.64	136	1.5	V	10.36	0.30	9.40	19.46	38.45	-18.99
LTE Band 26 Channel 26765 – 5MHz – QPSK										
821.50	70.52	159	1.5	H	7.15	0.30	9.40	16.25	38.45	-22.2
821.50	77.28	195	1.5	V	10.79	0.30	9.40	19.89	38.45	-18.56
LTE Band 26 Channel 26715 – 5MHz – 16QAM										
816.50	71.05	262	1.5	H	6.10	0.30	9.40	15.2	38.45	-23.25
816.50	77.61	223	1.5	V	10.14	0.30	9.40	19.24	38.45	-19.21
LTE Band 26 Channel 26740 – 5MHz – 16QAM										
819.00	70.52	241	1.5	H	6.03	0.30	9.40	15.13	38.45	-23.32
819.00	75.78	141	1.5	V	9.78	0.30	9.40	18.88	38.45	-19.57
LTE Band 26 Channel 26765 – 5MHz – 16QAM										
821.50	70.35	165	1.5	H	6.48	0.30	9.40	15.58	38.45	-22.87
821.50	76.97	143	1.5	V	10.65	0.30	9.40	19.75	38.45	-18.7

Frequency	Receiver Reading	Turn table Angle	RX Antenna		Substituted			Absolute Level	Result	
			Height	Polar	SG Level	Cable	Antenna Gain		Limit	Margin
(MHz)	(dB μ V)	Degree	(m)	(H/V)	(dBm)	(dB)	(dB)	(dBm)	(dBm)	(dB)
LTE Band 26 Channel 26740 – 10MHz – QPSK										
819.00	70.52	162	1.5	H	6.11	0.30	9.40	15.21	38.45	-23.24
819.00	76.47	175	1.5	V	10.71	0.30	9.40	19.81	38.45	-18.64
LTE Band 26 Channel 26740 – 10MHz – 16QAM										
819.00	70.35	265	1.5	H	6.52	0.30	9.40	15.62	38.45	-22.83
819.00	75.03	124	1.5	V	11.14	0.30	9.40	20.24	38.45	-18.21

9 Peak-to-Average Ratio

Test Requirement:	24.232 (d), 27.50(d)
Test Method:	N/A
Test Mode:	TX transmitting

9.1 EUT Operation

Operating Environment :

Temperature:	22.5 °C
Humidity:	52.3% RH
Atmospheric Pressure:	101.2kPa

9.2 Test Procedure

1. The EUT was connected to spectrum analyzer and system simulator via a power divider.
2. Set EUT to transmit at maximum output power.
3. When the duty cycle is less than 98%, then signal gating will be implemented on the spectrum analyzer by triggering from the system simulator.
4. Set the CCDF (Complementary Cumulative Distribution Function) option of the spectrum analyzer. Record the maximum PAPR level associated with a probability of 0.1%.

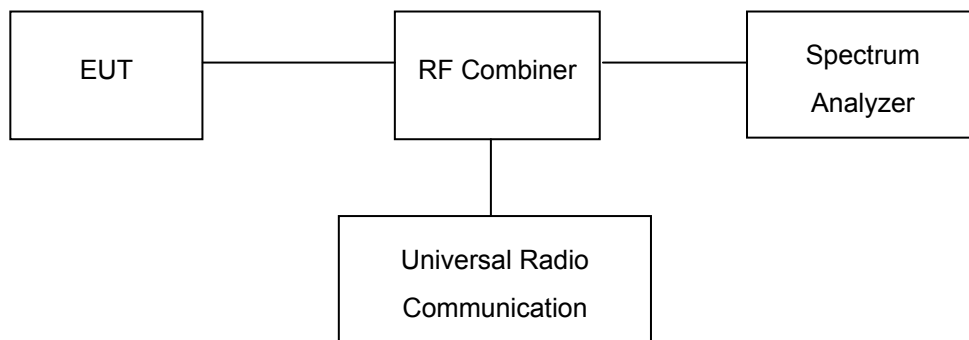

9.3 Test Result

Please refer to Appendix B

Test result: Pass

10 BANDWIDTH

Test Requirement:	FCC Part 2.1049; 90.691
Test Method:	TIA/EIA-603-E:2016 KDB 971168 D01 Power Meas License Digital Systems v03
Test Mode:	TX transmitting

10.1 EUT Operation

Operating Environment :

Temperature:	22.5 °C
Humidity:	52.3% RH
Atmospheric Pressure:	101.2kPa

10.2 Test Procedure

The RF output of the transmitter was connected to the wireless test set and the spectrum analyzer through sufficient attenuation.

The resolution bandwidth of the spectrum analyzer was set in the range of 1 to 5 % of the anticipated OBW and the 26 dB & 99%bandwidth was recorded.

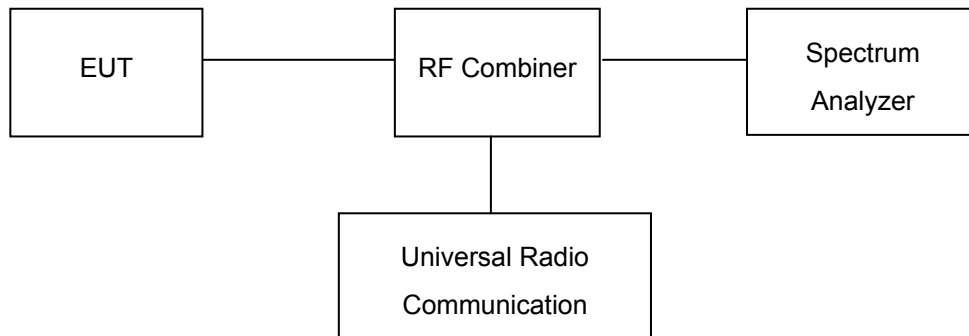

10.3 Test Result

Please refer to Appendix C

Test result: Pass

11 SPURIOUS EMISSIONS AT ANTENNA TERMINALS

Test Requirement:	FCC Part 2.1051,90.691
Test Method:	TIA/EIA-603-E:2016 KDB 971168 D01 Power Meas License Digital Systems v03
Test Mode:	TX transmitting

11.1 EUT Operation

Operating Environment :

Temperature:	23.5 °C
Humidity:	52.1 % RH
Atmospheric Pressure:	101.3kPa

11.2 Test Procedure

The RF output of the transceiver was connected to a spectrum analyzer and simulator through appropriate attenuation. The resolution bandwidth of the spectrum analyzer was set at 1MHz. Sufficient scans were taken to show any out of band emissions up to 10th harmonics.

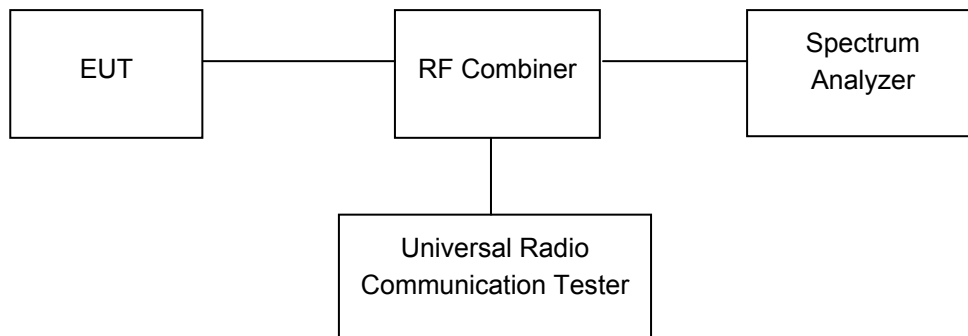

11.3 Test Result

PASS

LTE Band

Please refer to Appendix E: Conducted Spurious Emission

Test result: Pass

12 SPURIOUS RADIATED EMISSIONS

Test Requirement:	FCC Part 2.1053, 90.691
Test Method:	TIA/EIA-603-E:2016 KDB 971168 D01 Power Meas License Digital Systems v03
Test Mode:	TX transmitting

12.1 EUT Operation

Operating Environment :	
Temperature:	23.5 °C
Humidity:	52.1 % RH
Atmospheric Pressure:	101.2kPa

12.2 Test Setup

The radiated emission tests were performed in the 3m Semi- Anechoic Chamber test site. The test setup for emission measurement from 30 MHz to 1 GHz.

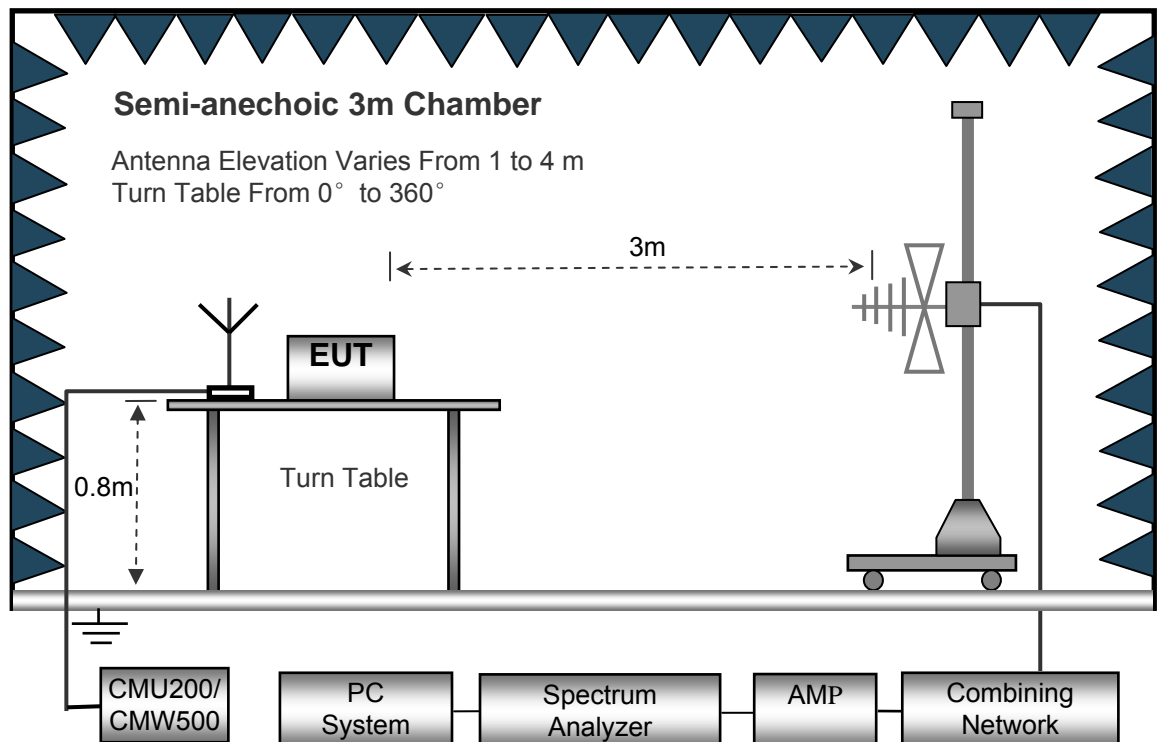

The test setup for emission measurement above 1 GHz.

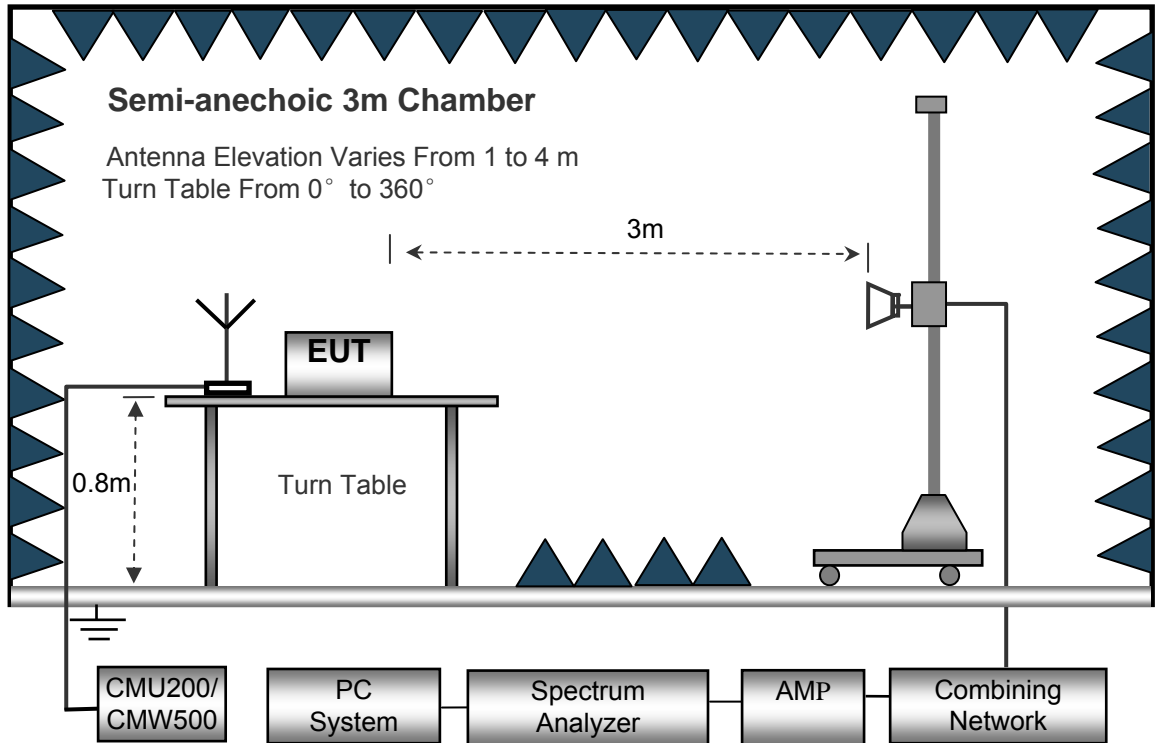

12.3 Spectrum Analyzer Setup

30MHz ~ 1GHz

Sweep Speed Auto
 Detector PK
 Resolution Bandwidth..... 100kHz
 Video Bandwidth..... 300kHz

Above 1GHz

Sweep Speed Auto
 Detector PK
 Resolution Bandwidth..... 1MHz
 Video Bandwidth..... 3MHz
 Detector Ave.
 Resolution Bandwidth..... 1MHz
 Video Bandwidth..... 10Hz

12.4 Test Procedure

1. The EUT is placed on a turntable, which is 0.8m above ground plane.
2. The turntable shall be rotated for 360 degrees to determine the position of maximum emission level.
3. EUT is set 3m away from the receiving antenna, which is moved from 1m to 4m to find out the maximum emissions. The spectrum was investigated from 30MHz up to the tenth harmonic of the highest fundamental frequency.
4. Maximum procedure was performed on the six highest emissions to ensure EUT compliance.
5. And also, each emission was to be maximized by changing the polarization of receiving antenna both horizontal and vertical.
6. The radiation measurements are tested under 3-axes(X,Y,Z) position(X denotes lying on the table, Y denotes side stand and Z denotes vertical stand), After pre-test, It was found that the worse radiation emission was get at the Z position. So the data shown was the Z position only.
7. Remove the EUT and replace it with substitution antenna. A signal generator was connected to the substitution antenna by a non-radiating cable. The absolute levels of the spurious emissions were measured by the substitution.

Spurious emissions in dB = $10 \lg (\text{TXpwr in Watts}/0.001)$ – the absolute level

Spurious attenuation limit in dB = $43 + 10 \text{Log}_{10} (\text{power out in Watts})$

8. Repeat above procedures until the measurements for all frequencies are completed.

12.5 Summary of Test Results

Remark: Test performed from 30MHz to 10th harmonics with low/middle/high channels, only the worst data were recorded.

LTE Band 26

Remark: (Uplink: 814-824MHz is for FCC Part 90)

Part 90:

Frequency (MHz)	Receiver Reading (dBμV)	Turn table Angle Degree	RX Antenna		Substituted			Absolute Level (dBm)	Result	
			Height (m)	Polar (H/V)	SG Level (dBm)	Cable (dB)	Antenna Gain (dB)		Limit (dBm)	Margins (dB)
LTE BAND 26 Channel 26697										
252.11	41.28	245	150	H	-70.65	0.15	0.00	-70.80	-13.00	-57.80
252.11	33.45	156	150	V	-75.25	0.15	0.00	-75.40	-13.00	-62.40
1629.40	62.52	87	150	H	-44.14	2.34	12.40	-34.08	-13.00	-21.08
1629.40	60.45	136	150	V	-50.36	2.34	12.40	-40.30	-13.00	-27.30
2444.10	54.05	215	150	H	-54.25	2.79	12.70	-44.34	-13.00	-31.34
2444.10	44.79	156	150	V	-63.11	2.79	12.70	-53.20	-13.00	-40.20
LTE BAND 26 Channel 26740										
269.15	40.35	129	150	H	-69.32	0.15	0.00	-69.47	-13.00	-56.47
269.15	34.96	251	150	V	-76.52	0.15	0.00	-76.67	-13.00	-63.67
1638.00	63.52	124	150	H	-43.51	2.37	12.50	-33.38	-13.00	-20.38
1638.00	60.44	236	150	V	-49.28	2.37	12.50	-39.15	-13.00	-26.15
2457.00	55.32	284	150	H	-53.58	2.79	12.70	-43.67	-13.00	-30.67
2457.00	45.66	151	150	V	-62.11	2.79	12.70	-52.2	-13.00	-39.20
LTE BAND 26 Channel 26783										
485.21	38.69	141	150	H	-70.35	0.98	0.00	-71.33	-13.00	-58.33
485.21	35.14	247	150	V	-75.65	0.98	0.00	-76.63	-13.00	-63.63
1646.60	62.02	254	150	H	-43.59	2.37	12.50	-33.46	-13.00	-20.46
1646.60	60.95	36	150	V	-49.21	2.37	12.50	-39.08	-13.00	-26.08
2469.90	54.05	175	150	H	-50.17	2.79	12.70	-40.26	-13.00	-27.26
2469.90	46.47	136	150	V	-62.65	2.79	12.70	-52.74	-13.00	-39.74

Note: 1) Absolute Level = SG Level - Cable loss + Antenna Gain

2) Margin = Absolute Level - Limit

13 Band Edge(Mask) Measurement

Test Requirement:	FCC Part 2.1051, 22.917(a), 90.691
Test Method:	TIA/EIA-603-E:2016 KDB 971168 D01 Power Meas License Digital Systems v03
Test Mode:	TX transmitting

13.1 EUT Operation

Operating Environment :	
Temperature:	23.5 °C
Humidity:	52.3 % RH
Atmospheric Pressure:	101.3kPa

13.2 Test Procedure

The RF output of the transmitter was connected to the input of the spectrum analyzer through sufficient attenuation.

According to FCC Part 22.917(a), the power of any emissions outside of the authorized operating frequency ranges must be attenuated below the TX transmitting power (P) by a factor of at least $43 + 10 \log(P)$ dB.

According to FCC Part 24.238(a), the power of any emissions outside of the authorized operating frequency ranges must be attenuated below the TX transmitting power (P) by a factor of at least $43 + 10 \log(P)$ dB.

According to FCC Part 27.53(h), Except as otherwise specified below, for operations in the 1695-1710 MHz, 1710-1755 MHz, 1755-1780 MHz, 1915-1920 MHz, 1995-2000 MHz, 2000-2020 MHz, 2110-2155 MHz, 2155-2180 MHz, and 2180-2200 bands, the power of any emission outside a licensee's frequency block shall be attenuated below the transmitter power (P) in watts by at least $43 + 10 \log_{10}(P)$ dB.

According to FCC Part 27.53(m)(4), For mobile digital stations, the attenuation factor shall be not less than $40 + 10 \log(P)$ dB on all frequencies between the channel edge and 5 megahertz from the channel edge, $43 + 10 \log(P)$ dB on all frequencies between 5 megahertz and X megahertz from the channel edge, and $55 + 10 \log(P)$ dB on all frequencies more than X megahertz from the channel edge, where X is the greater of 6 megahertz or the actual emission bandwidth as defined in paragraph (m)(6) of this section. In addition, the attenuation factor shall not be less than $43 + 10 \log(P)$ dB on all frequencies between 2490.5 MHz and 2496 MHz and $55 + 10 \log(P)$ dB at or below 2490.5 MHz. Mobile Satellite Service licensees operating on frequencies below 2495 MHz may also submit a documented interference complaint against BRS licensees operating on channel BRS Channel 1 on the same terms and conditions as adjacent channel BRS or EBS licensees.

(a) Out-of-band emission requirement shall apply only to the “outer” channels included in an EA license and to spectrum adjacent to interior channels used by incumbent licensees. The emission limits are as follows:

(1) For any frequency removed from the EA licensee's frequency block by up to and including 37.5 kHz, the power of any emission shall be attenuated below the transmitter power (P) in watts by at least $116 \log_{10}(f/6.1)$ decibels or $50 + 10 \log_{10}(P)$ decibels or 80 decibels, whichever is the lesser attenuation, where f is the frequency removed from the center of the outer channel in the block in kilohertz and where f is greater than 12.5 kHz.

(2) For any frequency removed from the EA licensee's frequency block greater than 37.5 kHz, the power of any emission shall be attenuated below the transmitter power (P) in watts by at least $43 + 10 \log_{10}(P)$ decibels or 80 decibels, whichever is the lesser attenuation, where f is the frequency removed from the center of the outer channel in the block in kilohertz and where f is greater than 37.5 kHz.

(b) When an emission outside of the authorized bandwidth causes harmful interference, the Commission may, at its discretion, require greater attenuation than specified in this section.

The center of the spectrum analyzer was set to block edge frequency

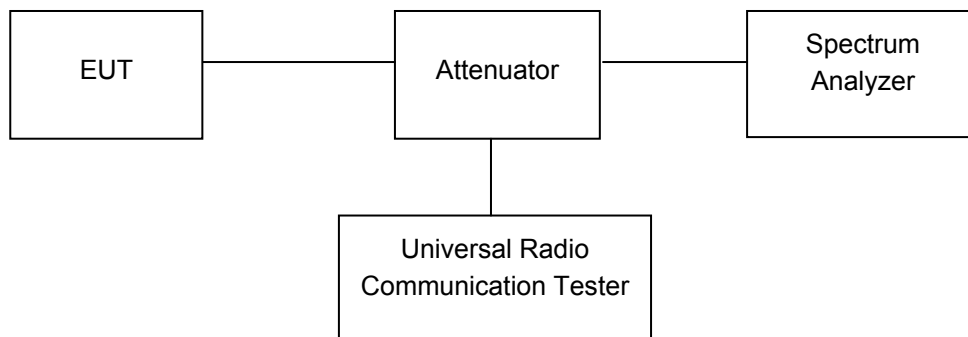

13.3 Test Result

Please refer to Appendix D: Band Edge

Test result: Pass

14 FREQUENCY STABILITY

Test Requirement:	FCC Part 2.1055, 22.355,90.691
Test Method:	TIA/EIA-603-E:2016 KDB 971168 D01 Power Meas License Digital Systems v03
Test Mode:	TX transmitting

14.1 EUT Operation

Operating Environment :	
Temperature:	22.9 °C
Humidity:	52.0 % RH
Atmospheric Pressure:	101.3kPa

14.2 Test Procedure

Frequency Stability vs. Temperature: The equipment under test was connected to an external DC power supply and the RF output was connected to communication test set via feed-through attenuators. The EUT was placed inside the temperature chamber. The DC leads and RF output cable exited the chamber through an opening made for the purpose.

After the temperature stabilized for approximately 20 minutes, the frequency output was recorded from the communication test set.

Frequency Stability vs. Voltage: For hand carried, battery powered equipment; reduce primary supply voltage to the battery operating end point which shall be specified by the manufacturer.

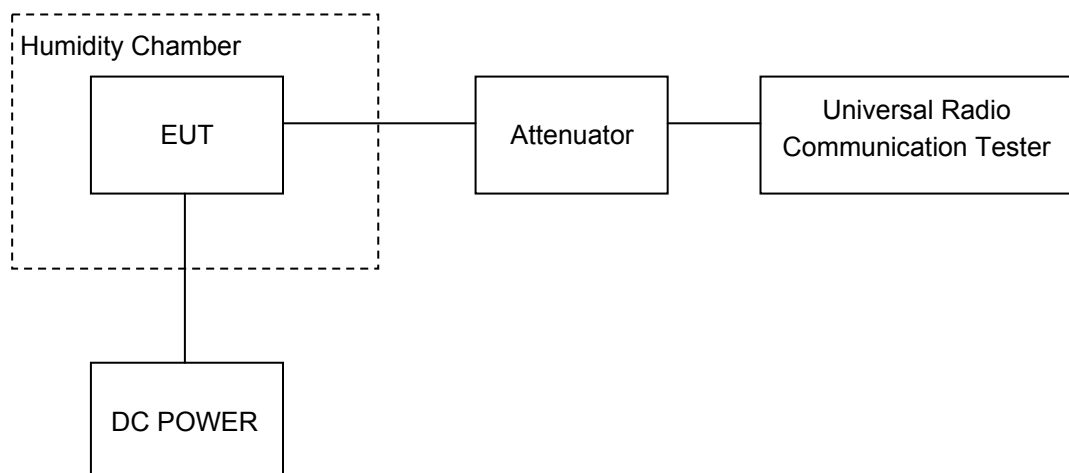

14.3 Test Result

Note: 1.Normal Voltage NV=DC3.85V; Low Voltage LV=DC3.5V;High Voltage HV=DC4.35V.

Please refer to Appendix F: Frequency Stability

Test result: Pass

===== End of Report =====