

Test Mode:	802.11ac-VHT80 - Ant 1 + 2	Test Site:	AC2
Test Channel:	106	Test Engineer:	Jone Zhang
Remark:	1. Average measurement was not performed if peak level lower than average limit. 2. Other frequency was 20dB below limit line within 1-18GHz, there is not show in the report.		

Mark	Frequency (MHz)	Reading Level (dBμV)	Factor (dB)	Measure Level (dBμV/m)	Limit (dBμV/m)	Margin (dB)	Detector	Polarization
	7383.5	36.5	12.6	49.1	74.0	-24.9	Peak	Horizontal
	8250.5	35.9	12.9	48.8	74.0	-25.2	Peak	Horizontal
*	9840.0	34.8	16.7	51.5	68.2	-16.7	Peak	Horizontal
*	10171.5	34.1	17.0	51.1	68.2	-17.1	Peak	Horizontal
	7434.5	36.1	12.8	48.9	74.0	-25.1	Peak	Vertical
	8208.0	35.3	13.0	48.3	74.0	-25.7	Peak	Vertical
*	9823.0	33.5	16.5	50.0	68.2	-18.2	Peak	Vertical
*	10222.5	33.1	17.1	50.2	68.2	-18.0	Peak	Vertical

Note 1: "\*" is not in restricted band, its limit is -27dBm/MHz. At a distance of 3 meters, the field strength limit in dBμV/m can be determined by adding a "conversion" factor of 95.2dB to the EIRP limit of -27dBm/MHz to obtain the limit for out of band spurious emissions.

Note 2: Measure Level (dBμV/m) = Reading Level (dBμV) + Factor (dB)

Factor (dB) = Cable Loss (dB) + Antenna Factor (dB/m) - Pre\_Amplifier Gain (dB)

Test Mode:	802.11ac-VHT80 - Ant 1 + 2	Test Site:	AC2
Test Channel:	122	Test Engineer:	Jone Zhang
Remark:	1. Average measurement was not performed if peak level lower than average limit. 2. Other frequency was 20dB below limit line within 1-18GHz, there is not show in the report.		

Mark	Frequency (MHz)	Reading Level (dBμV)	Factor (dB)	Measure Level (dBμV/m)	Limit (dBμV/m)	Margin (dB)	Detector	Polarization
	7468.5	35.4	12.9	48.3	74.0	-25.7	Peak	Horizontal
	8182.5	33.9	13.2	47.1	74.0	-26.9	Peak	Horizontal
*	9729.5	33.1	15.8	48.9	68.2	-19.3	Peak	Horizontal
*	10265.0	32.9	17.2	50.1	68.2	-18.1	Peak	Horizontal
	7460.0	35.4	12.9	48.3	74.0	-25.7	Peak	Vertical
	8242.0	33.9	13.0	46.9	74.0	-27.1	Peak	Vertical
*	9772.0	32.7	16.2	48.9	68.2	-19.3	Peak	Vertical
*	10273.5	32.9	17.2	50.1	68.2	-18.1	Peak	Vertical

Note 1: "\*" is not in restricted band, its limit is -27dBm/MHz. At a distance of 3 meters, the field strength limit in dBμV/m can be determined by adding a "conversion" factor of 95.2dB to the EIRP limit of -27dBm/MHz to obtain the limit for out of band spurious emissions.

Note 2: Measure Level (dBμV/m) = Reading Level (dBμV) + Factor (dB)

Factor (dB) = Cable Loss (dB) + Antenna Factor (dB/m) - Pre\_Amplifier Gain (dB)

Test Mode:	802.11ac-VHT80 - Ant 1 + 2	Test Site:	AC2
Test Channel:	138	Test Engineer:	Jone Zhang
Remark:	1. Average measurement was not performed if peak level lower than average limit. 2. Other frequency was 20dB below limit line within 1-18GHz, there is not show in the report.		

Mark	Frequency (MHz)	Reading Level (dBμV)	Factor (dB)	Measure Level (dBμV/m)	Limit (dBμV/m)	Margin (dB)	Detector	Polarization
	7519.5	35.7	12.8	48.5	74.0	-25.5	Peak	Horizontal
	8131.5	34.2	13.4	47.6	74.0	-26.4	Peak	Horizontal
*	9712.5	33.1	15.6	48.7	68.2	-19.5	Peak	Horizontal
*	10307.5	32.5	17.3	49.8	68.2	-18.4	Peak	Horizontal
	7647.0	35.1	12.7	47.8	74.0	-26.2	Peak	Vertical
	8242.0	34.7	13.0	47.7	74.0	-26.3	Peak	Vertical
*	9874.0	33.3	16.8	50.1	68.2	-18.1	Peak	Vertical
*	10214.0	33.2	17.1	50.3	68.2	-17.9	Peak	Vertical

Note 1: "\*" is not in restricted band, its limit is -27dBm/MHz. At a distance of 3 meters, the field strength limit in dBμV/m can be determined by adding a "conversion" factor of 95.2dB to the EIRP limit of -27dBm/MHz to obtain the limit for out of band spurious emissions.

Note 2: Measure Level (dBμV/m) = Reading Level (dBμV) + Factor (dB)

Factor (dB) = Cable Loss (dB) + Antenna Factor (dB/m) - Pre\_Amplifier Gain (dB)

Test Mode:	802.11ac-VHT80 - Ant 1 + 2	Test Site:	AC2
Test Channel:	155	Test Engineer:	Jone Zhang
Remark:	1. Average measurement was not performed if peak level lower than average limit. 2. Other frequency was 20dB below limit line within 1-18GHz, there is not show in the report.		

Mark	Frequency (MHz)	Reading Level (dBμV)	Factor (dB)	Measure Level (dBμV/m)	Limit (dBμV/m)	Margin (dB)	Detector	Polarization
	7655.5	35.1	12.7	47.8	74.0	-26.2	Peak	Horizontal
	8131.5	33.7	13.4	47.1	74.0	-26.9	Peak	Horizontal
*	9772.0	32.2	16.2	48.4	68.2	-19.8	Peak	Horizontal
*	10239.5	31.9	17.2	49.1	68.2	-19.1	Peak	Horizontal
	7443.0	35.3	12.9	48.2	74.0	-25.8	Peak	Vertical
	8182.5	33.5	13.2	46.7	74.0	-27.3	Peak	Vertical
*	9738.0	32.1	15.9	48.0	68.2	-20.2	Peak	Vertical
*	10222.5	32.1	17.1	49.2	68.2	-19.0	Peak	Vertical

Note 1: "\*" is not in restricted band, its limit is -27dBm/MHz or -17dBm/MHz. At a distance of 3 meters, the field strength limit in dBμV/m can be determined by adding a "conversion" factor of 95.2dB to the EIRP limit of -27dBm/MHz to obtain the limit for out of band spurious emissions.

Note 2: Measure Level (dBμV/m) = Reading Level (dBμV) + Factor (dB)

Factor (dB) = Cable Loss (dB) + Antenna Factor (dB/m) - Pre\_Amplifier Gain (dB)

**The worst case of Radiated Emission below 1GHz:**

Site: AC2	Time: 2018/01/03 - 14:49
Limit: FCC_Part15.209_RE(3m)	Engineer: Snake Ni
Probe: VULB 9168 _20-2000MHz	Polarity: Horizontal
EUT: VR All-In-One Headset	Power: AC 120V/60Hz
<b>Worst Mode:</b> Transmit at channel 5180MHz by 802.11a	

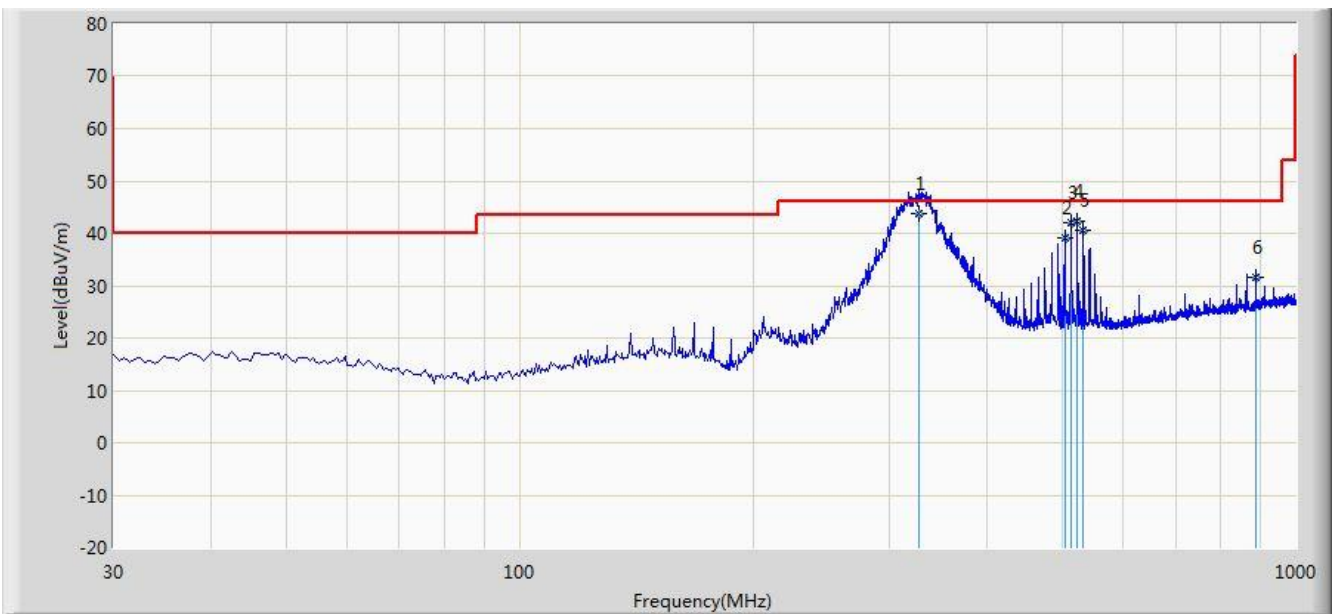

No	Flag	Mark	Frequency (MHz)	Measure Level (dBuV/m)	Reading Level (dBuV)	Over Limit (dB)	Limit (dBuV/m)	Factor (dB)	Type
1		*	326.335	43.765	28.654	-2.235	46.000	15.111	QP
2			503.845	39.053	20.409	-6.947	46.000	18.644	QP
3			513.545	41.943	23.100	-4.057	46.000	18.843	QP
4			523.245	42.424	23.386	-3.576	46.000	19.038	QP
5			532.945	40.476	21.244	-5.524	46.000	19.232	QP
6			887.965	31.688	7.426	-14.312	46.000	24.262	QP

Note 1: Measure Level (dB $\mu$ V/m) = Reading Level (dB $\mu$ V) + Factor (dB)

Factor (dB) = Cable Loss (dB) + Antenna Factor (dB/m)

Note 2: The test trace is same as the ambient noise and the amplitude of the emissions are attenuated more than 20dB below the permissible (the test frequency range: 9kHz ~ 30MHz, 18GHz ~ 25GHz), therefore no data appear in the report.

Site: AC2	Time: 2018/01/03 - 14:53
Limit: FCC_Part15.209_RE(3m)	Engineer: Snake Ni
Probe: VULB 9168 _20-2000MHz	Polarity: Vertical
EUT: VR All-In-One Headset	Power: AC 120V/60Hz
<b>Worst Mode:</b> Transmit at channel 5180MHz by 802.11a	

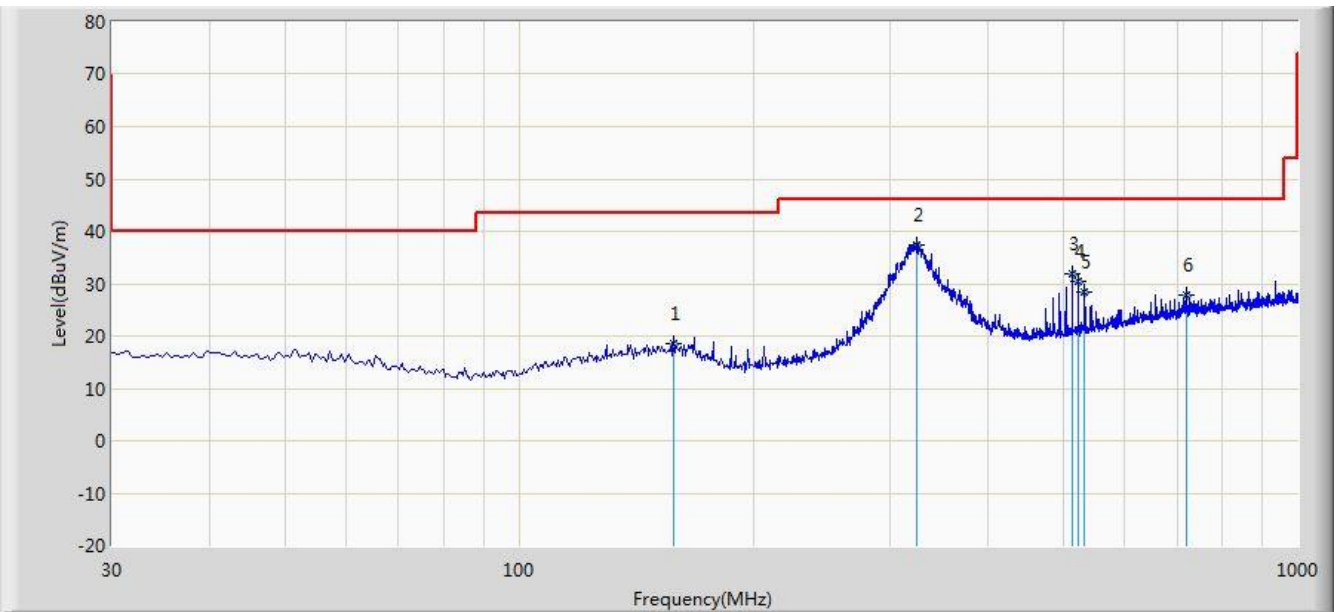

No	Flag	Mark	Frequency (MHz)	Measure Level (dBuV/m)	Reading Level (dBuV)	Over Limit (dB)	Limit (dBuV/m)	Factor (dB)	Type
1			158.040	18.469	3.171	-25.031	43.500	15.298	QP
2		*	324.880	37.309	22.224	-8.691	46.000	15.085	QP
3			513.545	31.830	12.987	-14.170	46.000	18.843	QP
4			523.245	30.482	11.444	-15.518	46.000	19.038	QP
5			532.945	28.366	9.134	-17.634	46.000	19.232	QP
6			720.155	27.786	5.398	-18.214	46.000	22.388	QP

Note 1: Measure Level (dB $\mu$ V/m) = Reading Level (dB $\mu$ V) + Factor (dB)

Factor (dB) = Cable Loss (dB) + Antenna Factor (dB/m)

Note 2: The test trace is same as the ambient noise and the amplitude of the emissions are attenuated more than 20dB below the permissible (the test frequency range: 9kHz ~ 30MHz, 18GHz ~ 25GHz), therefore no data appear in the report.

## 7.8. Radiated Restricted Band Edge Measurement

### 7.8.1. Test Limit

#### **For 15.205 requirement:**

Radiated emissions which fall in the restricted bands, as defined in Section 15.205(a) of FCC part 15, must also comply with the radiated emission limits specified in Section 15.209(a).

Frequency (MHz)	Frequency (MHz)	Frequency (MHz)	Frequency (GHz)
0.090 - 0.110	16.42 - 16.423	399.9 - 410	4.5 - 5.15
<sup>1</sup> 0.495 - 0.505	16.69475 - 16.69525	608 - 614	5.35 - 5.46
2.1735 - 2.1905	16.80425 - 16.80475	960 - 1240	7.25 - 7.75
4.125 - 4.128	25.5 - 25.67	1300 - 1427	8.25 - 8.5
4.17725 - 4.17775	37.5 - 38.25	1435 - 1626.5	9.0 - 9.2
4.20725 - 4.20775	73 - 74.6	1645.5 - 1646.5	9.3 - 9.5
6.215 - 6.218	74.8 - 75.2	1660 - 1710	10.6 - 12.7
6.26775 - 6.26825	108 - 121.94	1718.8 - 1722.2	13.25 - 13.4
6.31175 - 6.31225	123 - 138	2200 - 2300	14.47 - 14.5
8.291 - 8.294	149.9 - 150.05	2310 - 2390	15.35 - 16.2
8.362 - 8.366	156.52475 - 156.525	2483.5 - 2500	17.7 - 21.4
8.37625 - 8.38675	156.7 - 156.9	2690 - 2900	22.01 - 23.12
8.41425 - 8.41475	162.0125 - 167.17	3260 - 3267	23.6 - 24.0
12.29 - 12.293	167.72 - 173.2	3332 - 3339	31.2 - 31.8
12.51975 - 12.52025	240 - 285	3345.8 - 3358	36.43 - 36.5
12.57675 - 12.57725	322 - 335.4	3600 - 4400	( <sup>2</sup> )
13.36 - 13.41	--	--	--

#### **For 15.407(b) requirement:**

For transmitters operating in the 5.15-5.25 GHz band: All emissions outside of the 5.15-5.35 GHz band shall not exceed an e.i.r.p. of -27 dBm/MHz.

For transmitters operating in the 5.25-5.35 GHz band: All emissions outside of the 5.15-5.35 GHz band shall not exceed an e.i.r.p. of -27 dBm/MHz.

For transmitters operating in the 5.47-5.725 GHz band: All emissions outside of the 5.47-5.725 GHz band shall not exceed an e.i.r.p. of -27 dBm/MHz.

For transmitters operating in the 5.725-5.85 GHz band:

All emissions shall be limited to a level of -27 dBm/MHz at 75 MHz or more above or below the band edge increasing linearly to 10 dBm/MHz at 25 MHz above or below the band edge, and from 25 MHz

above or below the band edge increasing linearly to a level of 15.6 dBm/MHz at 5 MHz above or below the band edge, and from 5 MHz above or below the band edge increasing linearly to a level of 27 dBm/MHz at the band edge.

All out of band emissions appearing in a restricted band as specified in Section 15.205 of the Title 47 CFR must not exceed the limits shown in Table per Section 15.209.

FCC Part 15 Subpart C Paragraph 15.209		
Frequency [MHz]	Field Strength [uV/m]	Measured Distance [Meters]
0.009 – 0.490	2400/F (kHz)	300
0.490 – 1.705	24000/F (kHz)	30
1.705 - 30	30	30
30 - 88	100	3
88 - 216	150	3
216 - 960	200	3
Above 960	500	3



**7.8.2.Test Result**

Site: AC2	Time: 2017/12/02 - 14:34
Limit: FCC_Part15.209_RE(3m)	Engineer: Snake Ni
Probe: BBHA9120D_1-18GHz	Polarity: Horizontal
EUT: VR All-In-One Headset	Power: By Battery
Test Mode: Transmit by 802.11a at Channel 5180MHz Ant 0 + 1	

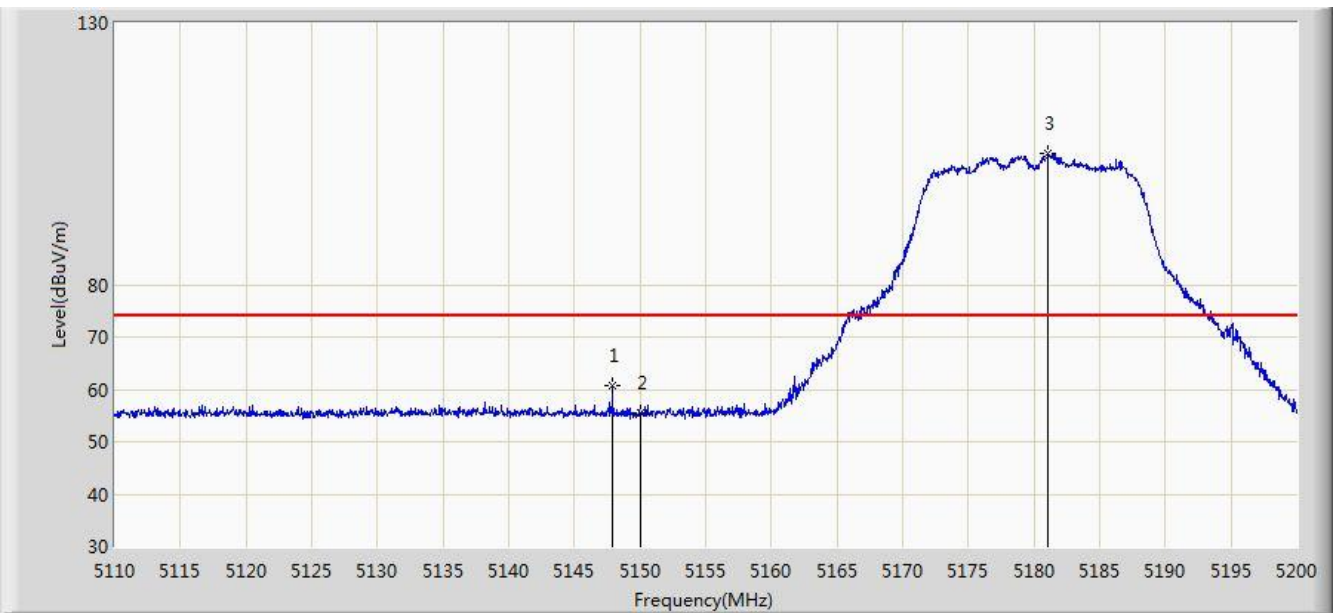

No	Flag	Mark	Frequency (MHz)	Measure Level (dBuV/m)	Reading Level (dBuV)	Over Limit (dB)	Limit (dBuV/m)	Factor (dB)	Type
1			5147.890	60.684	57.609	-13.316	74.000	3.075	PK
2			5150.000	55.533	52.463	-18.467	74.000	3.069	PK
3		*	5181.100	105.031	101.984	N/A	N/A	3.047	PK

Note: Measure Level (dBμV/m) = Reading Level (dBμV) + Factor (dB)

Factor (dB) = Cable Loss (dB) + Antenna Factor (dB/m) - Pre\_Amplifier Gain (dB)

Site: AC2	Time: 2017/12/02 - 14:37
Limit: FCC_Part15.209_RE(3m)	Engineer: Snake Ni
Probe: BBHA9120D_1-18GHz	Polarity: Horizontal
EUT: VR All-In-One Headset	Power: By Battery
Test Mode: Transmit by 802.11a at Channel 5180MHz Ant 0 + 1	



No	Flag	Mark	Frequency (MHz)	Measure Level (dBuV/m)	Reading Level (dBuV)	Over Limit (dB)	Limit (dBuV/m)	Factor (dB)	Type
1			5150.000	43.301	40.231	-10.699	54.000	3.069	AV
2		*	5178.940	93.377	90.338	N/A	N/A	3.040	AV

Note: Measure Level (dB $\mu$ V/m) = Reading Level (dB $\mu$ V) + Factor (dB)

Factor (dB) = Cable Loss (dB) + Antenna Factor (dB/m) - Pre\_Amplifier Gain (dB)

Site: AC2	Time: 2017/12/02 - 14:39
Limit: FCC_Part15.209_RE(3m)	Engineer: Snake Ni
Probe: BBHA9120D_1-18GHz	Polarity: Vertical
EUT: VR All-In-One Headset	Power: By Battery
Test Mode: Transmit by 802.11a at Channel 5180MHz Ant 0 + 1	

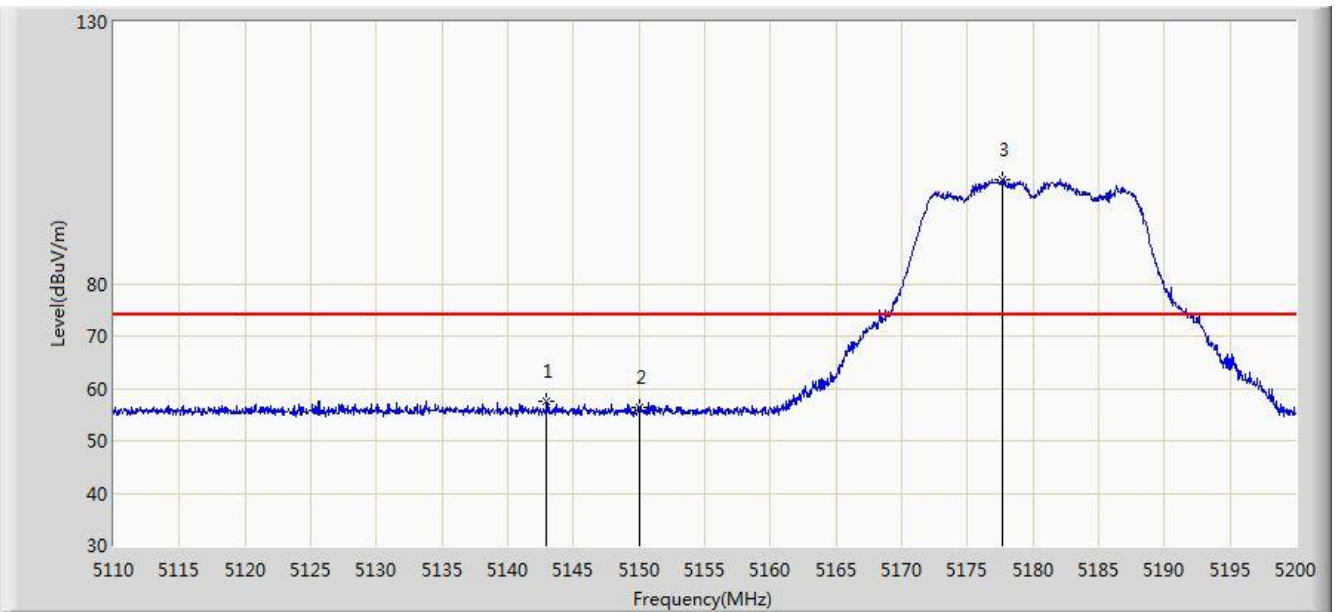

No	Flag	Mark	Frequency (MHz)	Measure Level (dBuV/m)	Reading Level (dBuV)	Over Limit (dB)	Limit (dBuV/m)	Factor (dB)	Type
1			5142.940	57.415	54.328	-16.585	74.000	3.087	PK
2			5150.000	56.392	53.322	-17.608	74.000	3.069	PK
3		*	5177.635	99.743	96.709	N/A	N/A	3.033	PK

Note: Measure Level (dBμV/m) = Reading Level (dBμV) + Factor (dB)

Factor (dB) = Cable Loss (dB) + Antenna Factor (dB/m) - Pre\_Amplifier Gain (dB)

Site: AC2	Time: 2017/12/02 - 14:40
Limit: FCC_Part15.209_RE(3m)	Engineer: Snake Ni
Probe: BBHA9120D_1-18GHz	Polarity: Vertical
EUT: VR All-In-One Headset	Power: By Battery
Test Mode: Transmit by 802.11a at Channel 5180MHz Ant 0 + 1	

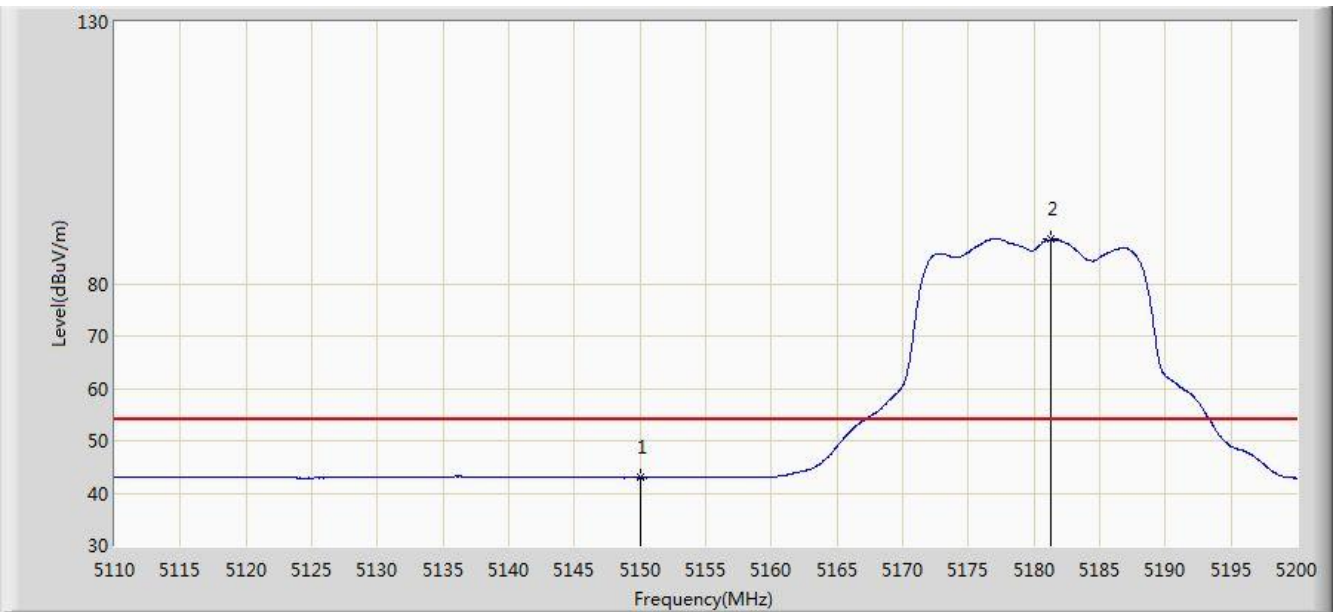

No	Flag	Mark	Frequency (MHz)	Measure Level (dBuV/m)	Reading Level (dBuV)	Over Limit (dB)	Limit (dBuV/m)	Factor (dB)	Type
1			5150.000	42.921	39.851	-11.079	54.000	3.069	AV
2		*	5181.325	88.437	85.389	N/A	N/A	3.048	AV

Note: Measure Level (dB $\mu$ V/m) = Reading Level (dB $\mu$ V) + Factor (dB)

Factor (dB) = Cable Loss (dB) + Antenna Factor (dB/m) - Pre\_Amplifier Gain (dB)

Site: AC2	Time: 2017/12/02 - 14:42
Limit: FCC_Part15.209_RE(3m)	Engineer: Snake Ni
Probe: BBHA9120D_1-18GHz	Polarity: Horizontal
EUT: VR All-In-One Headset	Power: By Battery
Test Mode: Transmit by 802.11a at Channel 5320MHz Ant 0 + 1	

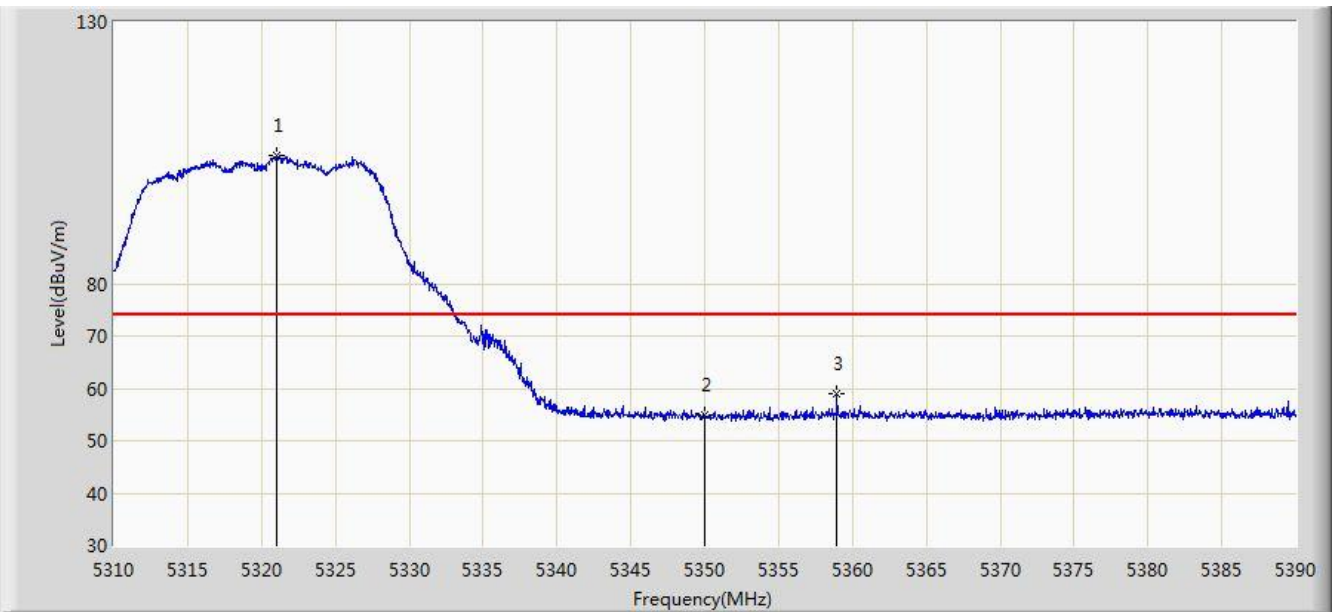

No	Flag	Mark	Frequency (MHz)	Measure Level (dBuV/m)	Reading Level (dBuV)	Over Limit (dB)	Limit (dBuV/m)	Factor (dB)	Type
1		*	5321.040	104.637	101.971	N/A	N/A	2.667	PK
2			5350.000	54.954	52.257	-19.046	74.000	2.697	PK
3			5358.960	59.028	56.309	-14.972	74.000	2.720	PK

Note: Measure Level (dBμV/m) = Reading Level (dBμV) + Factor (dB)

Factor (dB) = Cable Loss (dB) + Antenna Factor (dB/m) - Pre\_Amplifier Gain (dB)

Site: AC2	Time: 2017/12/02 - 14:43
Limit: FCC_Part15.209_RE(3m)	Engineer: Snake Ni
Probe: BBHA9120D_1-18GHz	Polarity: Horizontal
EUT: VR All-In-One Headset	Power: By Battery
Test Mode: Transmit by 802.11a at Channel 5320MHz Ant 0 + 1	

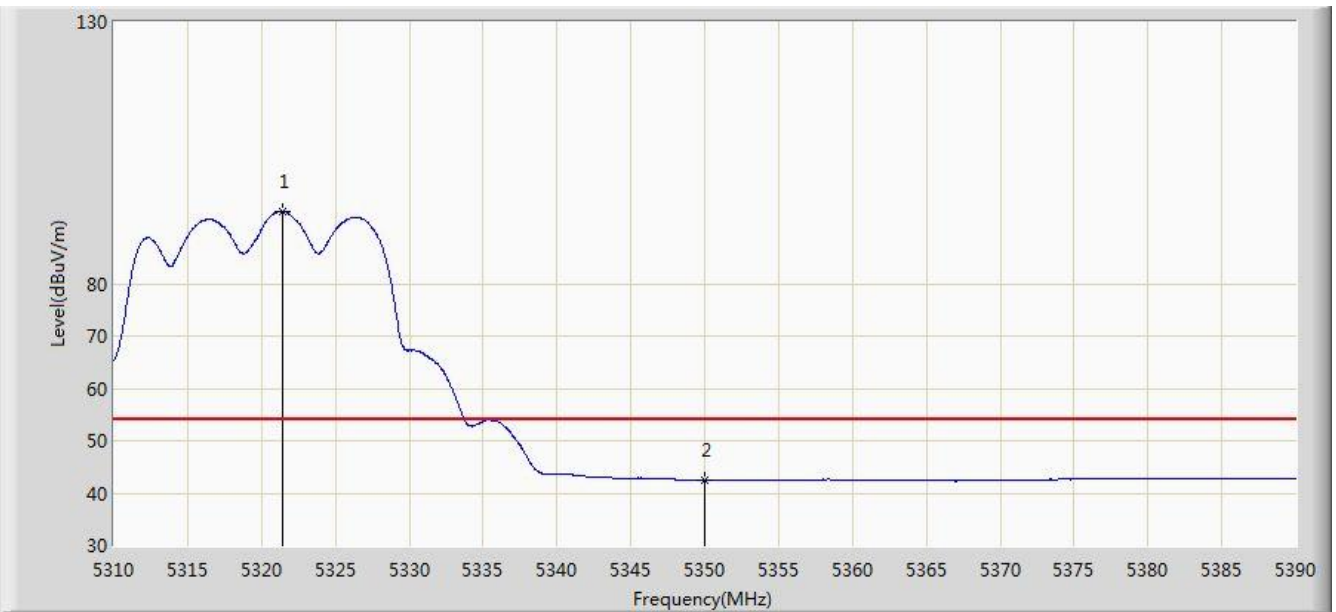

No	Flag	Mark	Frequency (MHz)	Measure Level (dBuV/m)	Reading Level (dBuV)	Over Limit (dB)	Limit (dBuV/m)	Factor (dB)	Type
1		*	5321.400	93.869	91.201	N/A	N/A	2.668	AV
2			5350.000	42.489	39.792	-11.511	54.000	2.697	AV

Note: Measure Level (dB $\mu$ V/m) = Reading Level (dB $\mu$ V) + Factor (dB)

Factor (dB) = Cable Loss (dB) + Antenna Factor (dB/m) - Pre\_Amplifier Gain (dB)

Site: AC2	Time: 2017/12/02 - 14:44
Limit: FCC_Part15.209_RE(3m)	Engineer: Snake Ni
Probe: BBHA9120D_1-18GHz	Polarity: Vertical
EUT: VR All-In-One Headset	Power: By Battery
Test Mode: Transmit by 802.11a at Channel 5320MHz Ant 0 + 1	

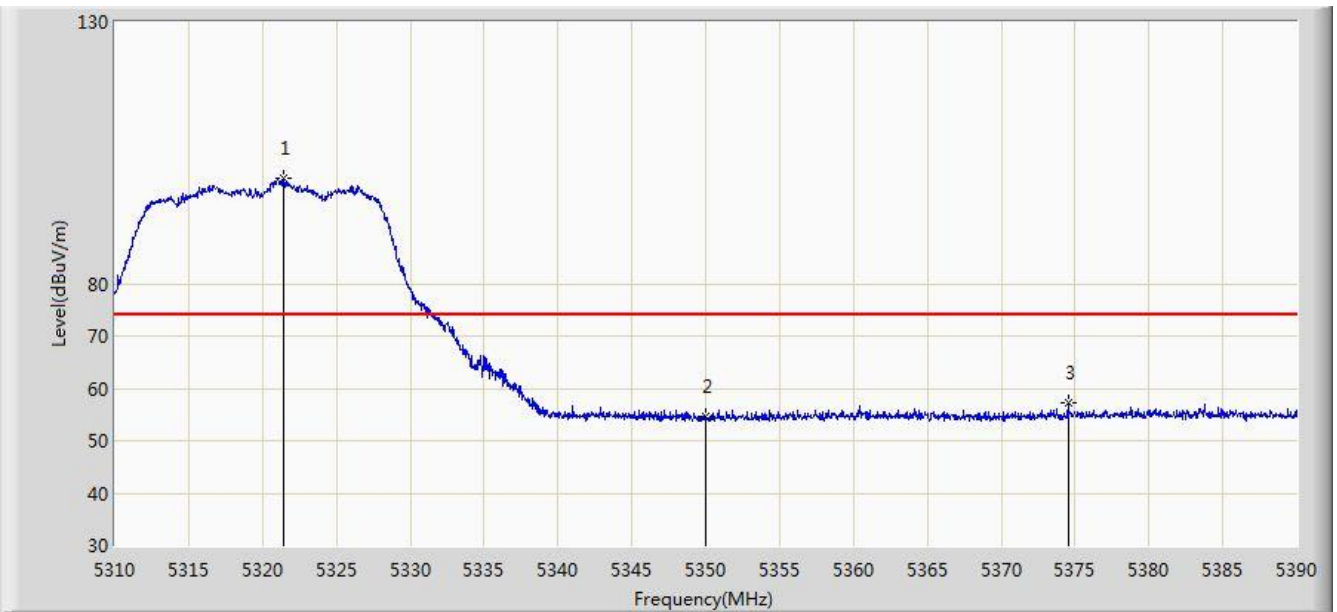

No	Flag	Mark	Frequency (MHz)	Measure Level (dBuV/m)	Reading Level (dBuV)	Over Limit (dB)	Limit (dBuV/m)	Factor (dB)	Type
1		*	5321.400	100.067	97.399	N/A	N/A	2.668	PK
2			5350.000	54.655	51.958	-19.345	74.000	2.697	PK
3			5374.520	57.300	54.351	-16.700	74.000	2.948	PK

Note: Measure Level (dB $\mu$ V/m) = Reading Level (dB $\mu$ V) + Factor (dB)

Factor (dB) = Cable Loss (dB) + Antenna Factor (dB/m) - Pre\_Amplifier Gain (dB)

Site: AC2	Time: 2017/12/02 - 14:46
Limit: FCC_Part15.209_RE(3m)	Engineer: Snake Ni
Probe: BBHA9120D_1-18GHz	Polarity: Vertical
EUT: VR All-In-One Headset	Power: By Battery
Test Mode: Transmit by 802.11a at Channel 5320MHz Ant 0 + 1	

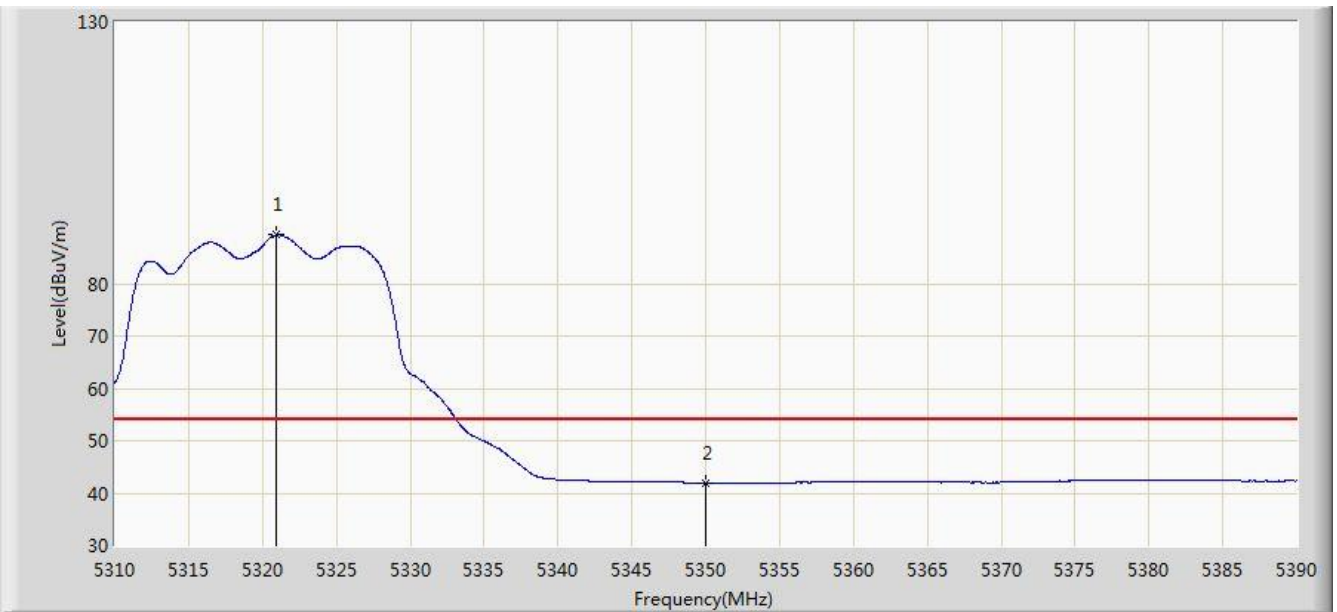

No	Flag	Mark	Frequency (MHz)	Measure Level (dBuV/m)	Reading Level (dBuV)	Over Limit (dB)	Limit (dBuV/m)	Factor (dB)	Type
1		*	5320.920	89.310	86.644	N/A	N/A	2.665	AV
2			5350.000	41.920	39.223	-12.080	54.000	2.697	AV

Note: Measure Level (dB $\mu$ V/m) = Reading Level (dB $\mu$ V) + Factor (dB)

Factor (dB) = Cable Loss (dB) + Antenna Factor (dB/m) - Pre\_Amplifier Gain (dB)



Site: AC2	Time: 2017/12/02 - 14:47
Limit: FCC_Part15.209_RE(3m)	Engineer: Snake Ni
Probe: BBHA9120D_1-18GHz	Polarity: Horizontal
EUT: VR All-In-One Headset	Power: By Battery
Test Mode: Transmit by 802.11a at Channel 5500MHz Ant 0 + 1	

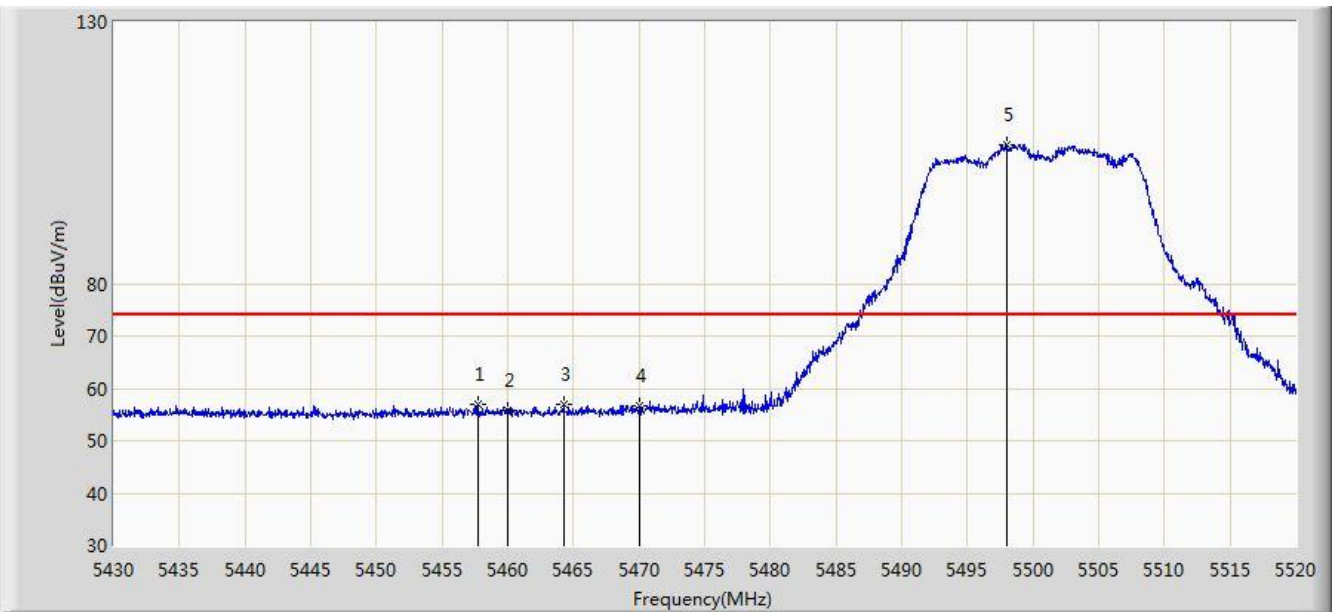

No	Flag	Mark	Frequency (MHz)	Measure Level (dBuV/m)	Reading Level (dBuV)	Over Limit (dB)	Limit (dBuV/m)	Factor (dB)	Type
1			5457.720	56.868	53.751	-17.132	74.000	3.117	PK
2			5460.000	55.800	52.607	-18.200	74.000	3.194	PK
3			5464.245	57.031	53.695	-16.969	74.000	3.336	PK
4			5470.000	56.556	53.027	-17.444	74.000	3.529	PK
5		*	5497.995	106.491	103.358	N/A	N/A	3.133	PK

Note: Measure Level (dBμV/m) = Reading Level (dBμV) + Factor (dB)

Factor (dB) = Cable Loss (dB) + Antenna Factor (dB/m) - Pre\_Amplifier Gain (dB)

Site: AC2	Time: 2017/12/02 - 14:49
Limit: FCC_Part15.209_RE(3m)	Engineer: Snake Ni
Probe: BBHA9120D_1-18GHz	Polarity: Horizontal
EUT: VR All-In-One Headset	Power: By Battery
Test Mode: Transmit by 802.11a at Channel 5500MHz Ant 0 + 1	

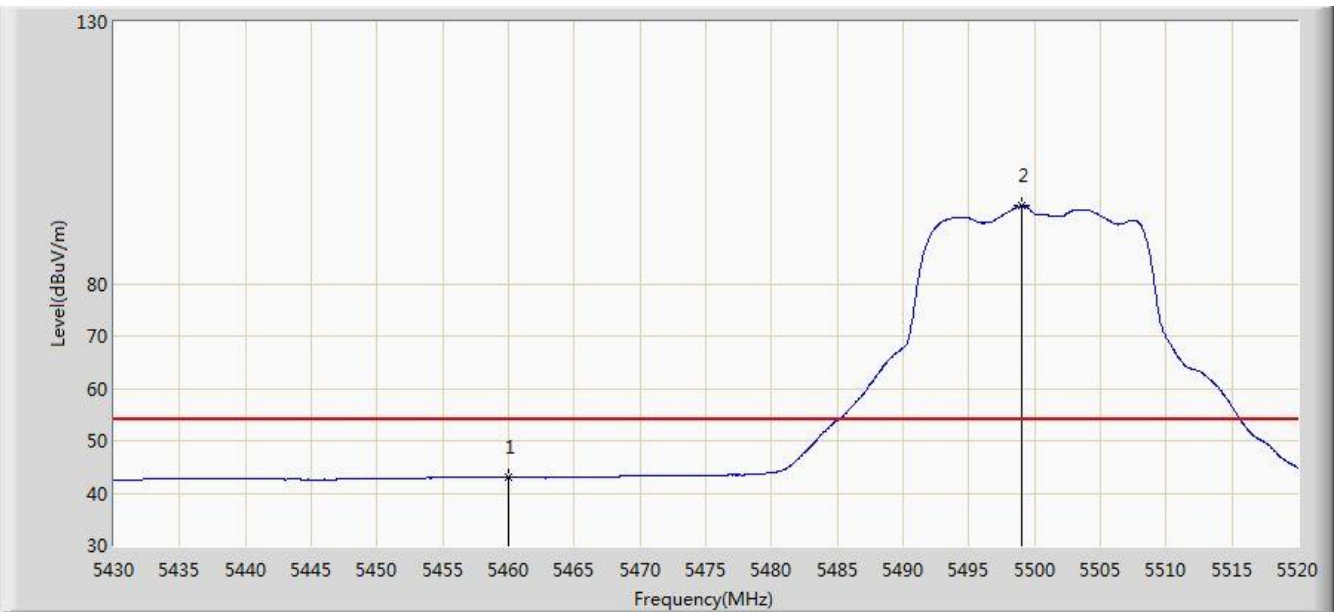

No	Flag	Mark	Frequency (MHz)	Measure Level (dBuV/m)	Reading Level (dBuV)	Over Limit (dB)	Limit (dBuV/m)	Factor (dB)	Type
1			5460.000	43.066	39.873	-10.934	54.000	3.194	AV
2		*	5499.075	94.874	91.752	N/A	N/A	3.122	AV

Note: Measure Level (dBμV/m) = Reading Level (dBμV) + Factor (dB)

Factor (dB) = Cable Loss (dB) + Antenna Factor (dB/m) - Pre\_Amplifier Gain (dB)

Site: AC2	Time: 2017/12/02 - 14:50
Limit: FCC_Part15.209_RE(3m)	Engineer: Snake Ni
Probe: BBHA9120D_1-18GHz	Polarity: Vertical
EUT: VR All-In-One Headset	Power: By Battery
Test Mode: Transmit by 802.11a at Channel 5500MHz Ant 0 + 1	

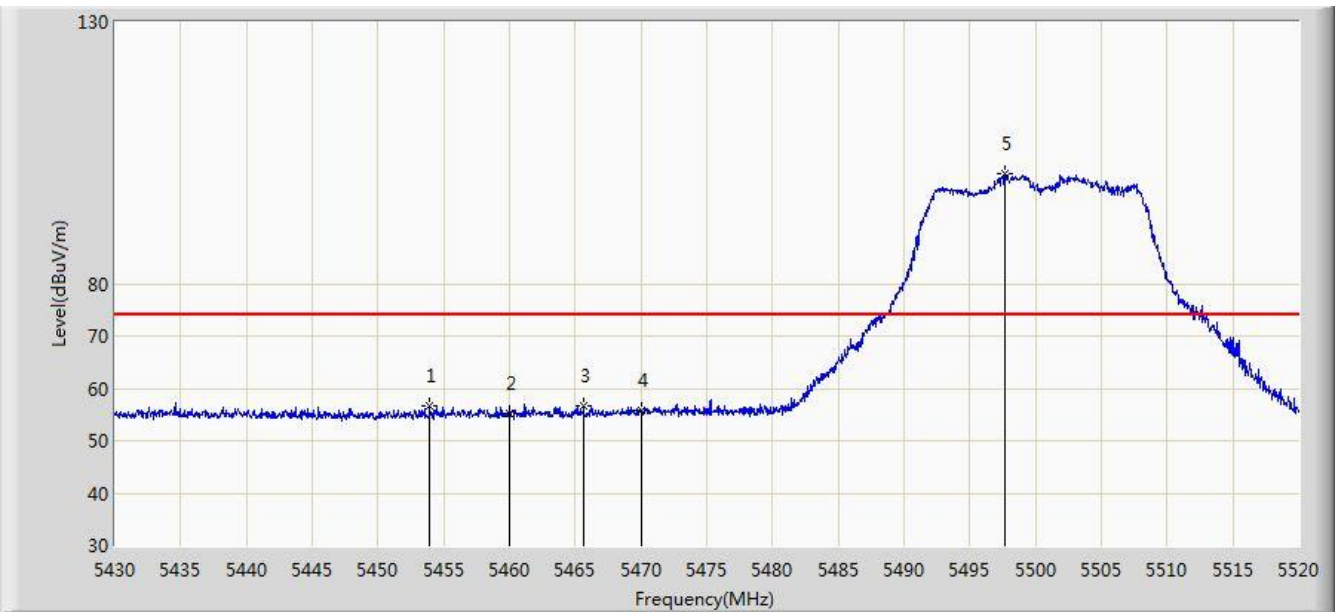

No	Flag	Mark	Frequency (MHz)	Measure Level (dBuV/m)	Reading Level (dBuV)	Over Limit (dB)	Limit (dBuV/m)	Factor (dB)	Type
1			5453.940	56.592	53.603	-17.408	74.000	2.989	PK
2			5460.000	55.327	52.134	-18.673	74.000	3.194	PK
3			5465.640	56.540	53.157	-17.460	74.000	3.383	PK
4			5470.000	55.762	52.233	-18.238	74.000	3.529	PK
5		*	5497.680	101.006	97.870	N/A	N/A	3.135	PK

Note: Measure Level (dBμV/m) = Reading Level (dBμV) + Factor (dB)

Factor (dB) = Cable Loss (dB) + Antenna Factor (dB/m) - Pre\_Amplifier Gain (dB)

Site: AC2	Time: 2017/12/02 - 14:52
Limit: FCC_Part15.209_RE(3m)	Engineer: Snake Ni
Probe: BBHA9120D_1-18GHz	Polarity: Vertical
EUT: VR All-In-One Headset	Power: By Battery
Test Mode: Transmit by 802.11a at Channel 5500MHz Ant 0 + 1	

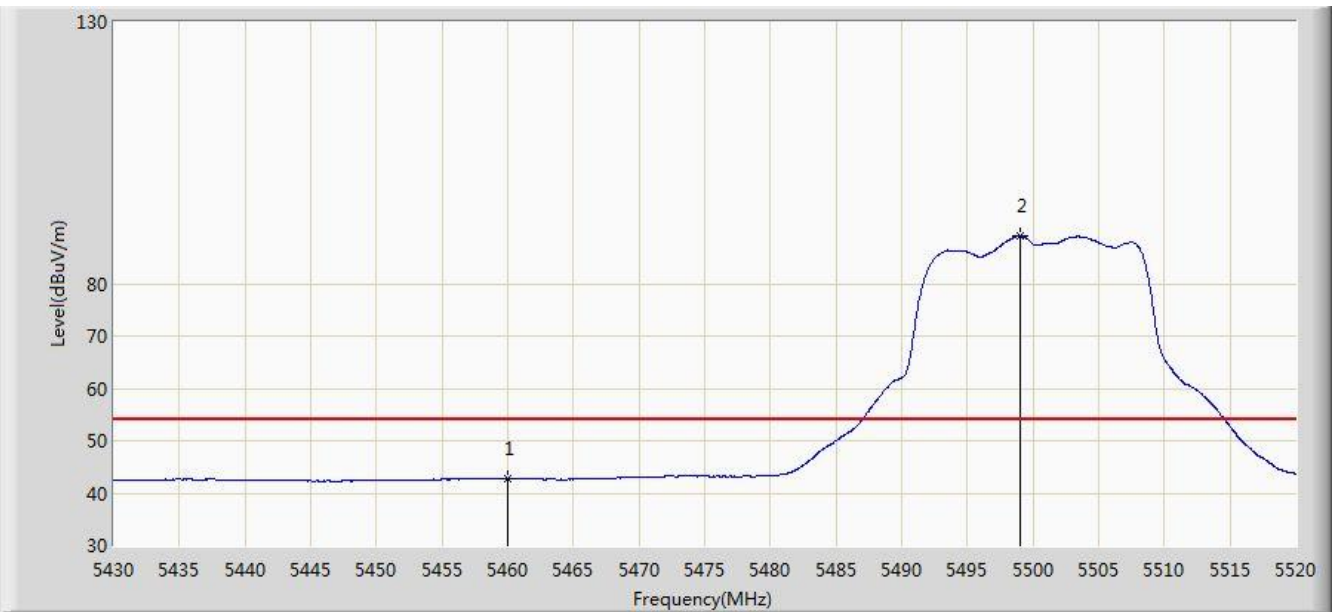

No	Flag	Mark	Frequency (MHz)	Measure Level (dBuV/m)	Reading Level (dBuV)	Over Limit (dB)	Limit (dBuV/m)	Factor (dB)	Type
1			5460.000	42.691	39.498	-11.309	54.000	3.194	AV
2		*	5499.075	89.174	86.052	N/A	N/A	3.122	AV

Note: Measure Level (dBμV/m) = Reading Level (dBμV) + Factor (dB)

Factor (dB) = Cable Loss (dB) + Antenna Factor (dB/m) - Pre\_Amplifier Gain (dB)

Site: AC2	Time: 2017/12/02 - 14:53
Limit: FCC_Part15.209_RE(3m)	Engineer: Snake Ni
Probe: BBHA9120D_1-18GHz	Polarity: Horizontal
EUT: VR All-In-One Headset	Power: By Battery
Test Mode: Transmit by 802.11a at Channel 5700MHz Ant 0 + 1	

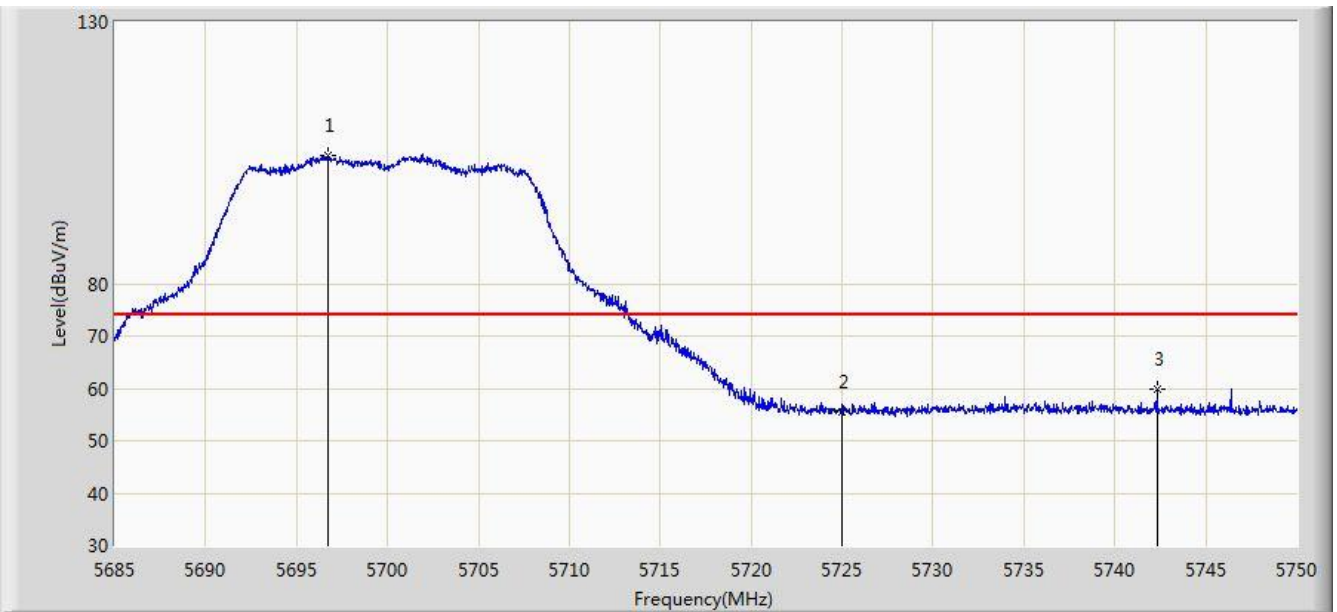

No	Flag	Mark	Frequency (MHz)	Measure Level (dBuV/m)	Reading Level (dBuV)	Over Limit (dB)	Limit (dBuV/m)	Factor (dB)	Type
1		*	5696.700	104.386	100.411	N/A	N/A	3.975	PK
2			5725.000	55.578	51.472	-18.422	74.000	4.105	PK
3			5742.330	59.859	55.587	-14.141	74.000	4.272	PK

Note: Measure Level (dB $\mu$ V/m) = Reading Level (dB $\mu$ V) + Factor (dB)

Factor (dB) = Cable Loss (dB) + Antenna Factor (dB/m) - Pre\_Amplifier Gain (dB)

Site: AC2	Time: 2017/12/02 - 14:55
Limit: FCC_Part15.209_RE(3m)	Engineer: Snake Ni
Probe: BBHA9120D_1-18GHz	Polarity: Horizontal
EUT: VR All-In-One Headset	Power: By Battery
Test Mode: Transmit by 802.11a at Channel 5700MHz Ant 0 + 1	

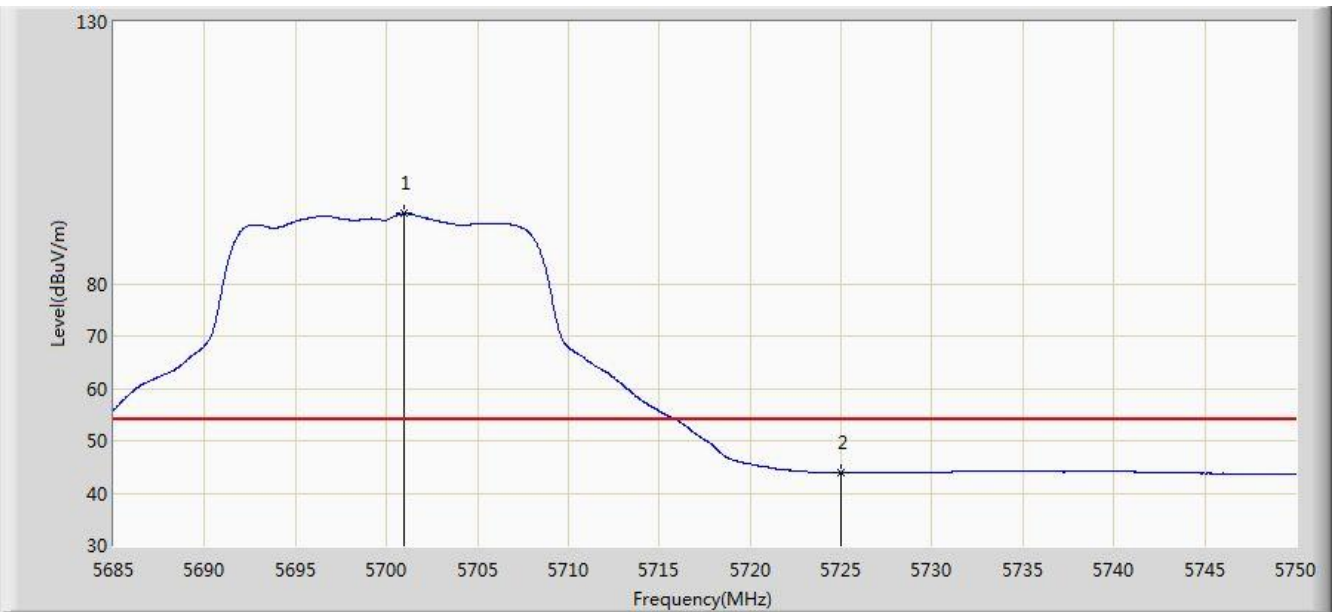

No	Flag	Mark	Frequency (MHz)	Measure Level (dBuV/m)	Reading Level (dBuV)	Over Limit (dB)	Limit (dBuV/m)	Factor (dB)	Type
1		*	5700.925	93.358	89.428	N/A	N/A	3.930	AV
2			5725.000	43.895	39.789	-10.105	54.000	4.105	AV

Note: Measure Level (dBμV/m) = Reading Level (dBμV) + Factor (dB)

Factor (dB) = Cable Loss (dB) + Antenna Factor (dB/m) - Pre\_Amplifier Gain (dB)

Site: AC2	Time: 2017/12/02 - 14:55
Limit: FCC_Part15.209_RE(3m)	Engineer: Snake Ni
Probe: BBHA9120D_1-18GHz	Polarity: Vertical
EUT: VR All-In-One Headset	Power: By Battery
Test Mode: Transmit by 802.11a at Channel 5700MHz Ant 0 + 1	

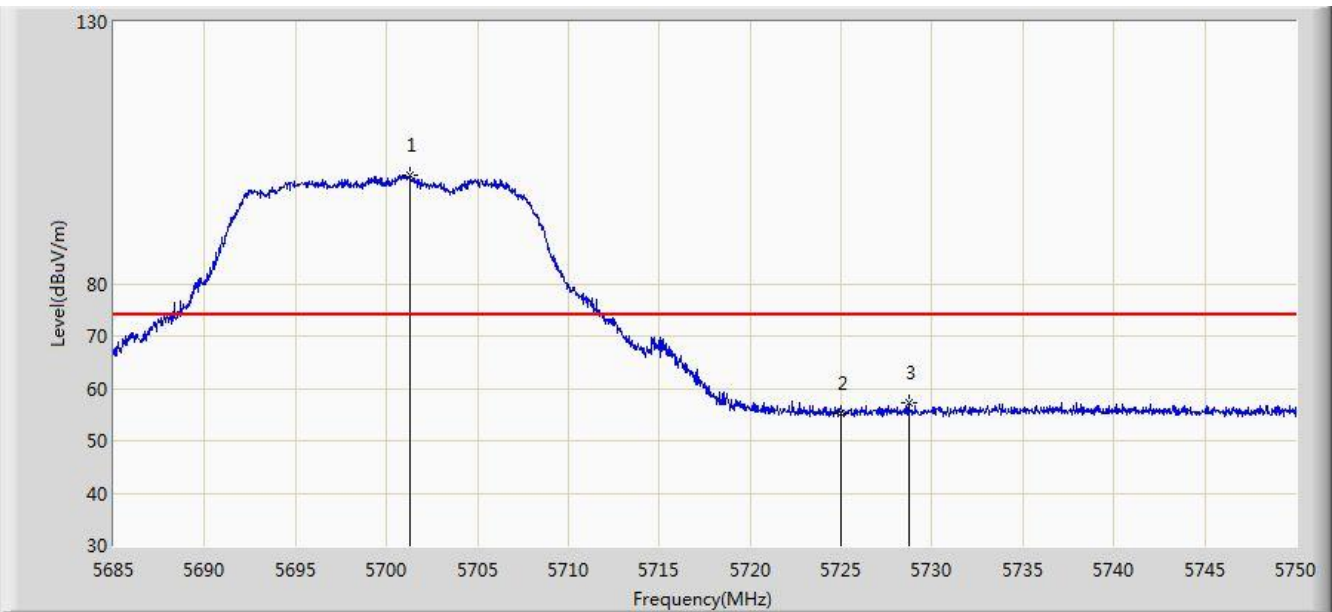

No	Flag	Mark	Frequency (MHz)	Measure Level (dBuV/m)	Reading Level (dBuV)	Over Limit (dB)	Limit (dBuV/m)	Factor (dB)	Type
1		*	5701.250	100.732	96.806	N/A	N/A	3.927	PK
2			5725.000	55.244	51.138	-18.756	74.000	4.105	PK
3			5728.712	57.374	53.175	-16.626	74.000	4.199	PK

Note: Measure Level (dB $\mu$ V/m) = Reading Level (dB $\mu$ V) + Factor (dB)

Factor (dB) = Cable Loss (dB) + Antenna Factor (dB/m) - Pre\_Amplifier Gain (dB)

Site: AC2	Time: 2017/12/02 - 14:57
Limit: FCC_Part15.209_RE(3m)	Engineer: Snake Ni
Probe: BBHA9120D_1-18GHz	Polarity: Vertical
EUT: VR All-In-One Headset	Power: By Battery
Test Mode: Transmit by 802.11a at Channel 5700MHz Ant 0 + 1	

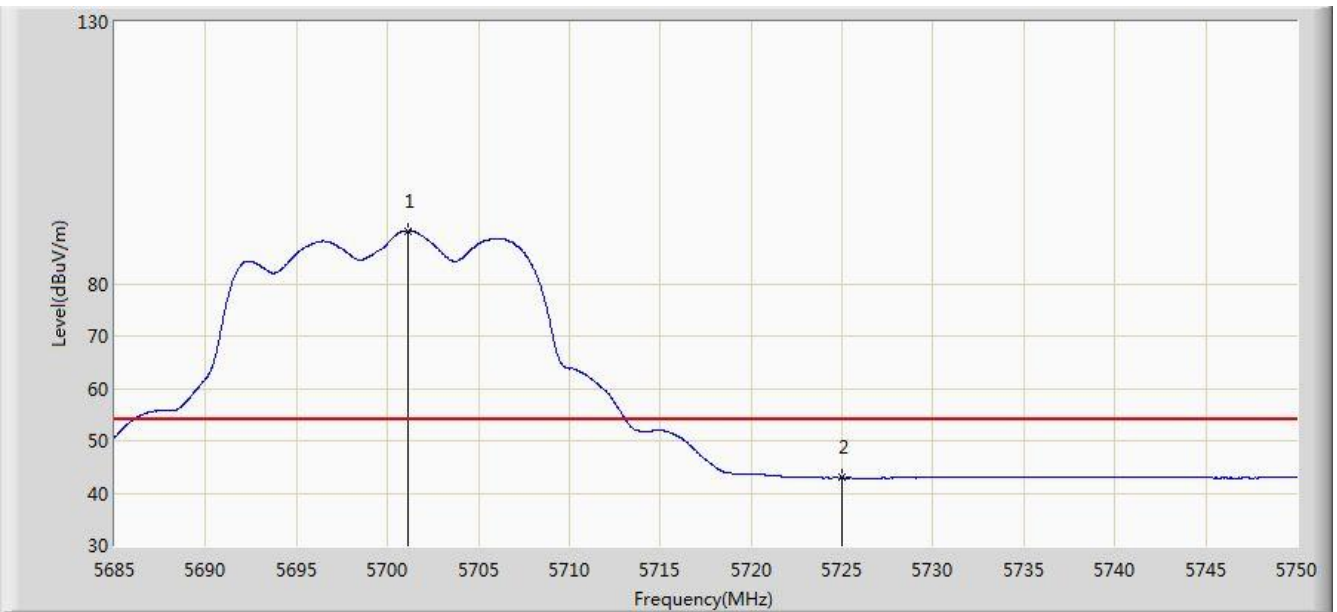

No	Flag	Mark	Frequency (MHz)	Measure Level (dBuV/m)	Reading Level (dBuV)	Over Limit (dB)	Limit (dBuV/m)	Factor (dB)	Type
1		*	5701.152	90.130	86.203	N/A	N/A	3.927	AV
2			5725.000	42.927	38.821	-11.073	54.000	4.105	AV

Note: Measure Level (dB $\mu$ V/m) = Reading Level (dB $\mu$ V) + Factor (dB)

Factor (dB) = Cable Loss (dB) + Antenna Factor (dB/m) - Pre\_Amplifier Gain (dB)



Site: AC2	Time: 2017/12/02 - 14:58
Limit: FCC_Part15.407_RE(3m)	Engineer: Snake Ni
Probe: BBHA9120D_1-18GHz	Polarity: Horizontal
EUT: VR All-In-One Headset	Power: By Battery
Test Mode: Transmit by 802.11a at Channel 5745MHz Ant 0 + 1	

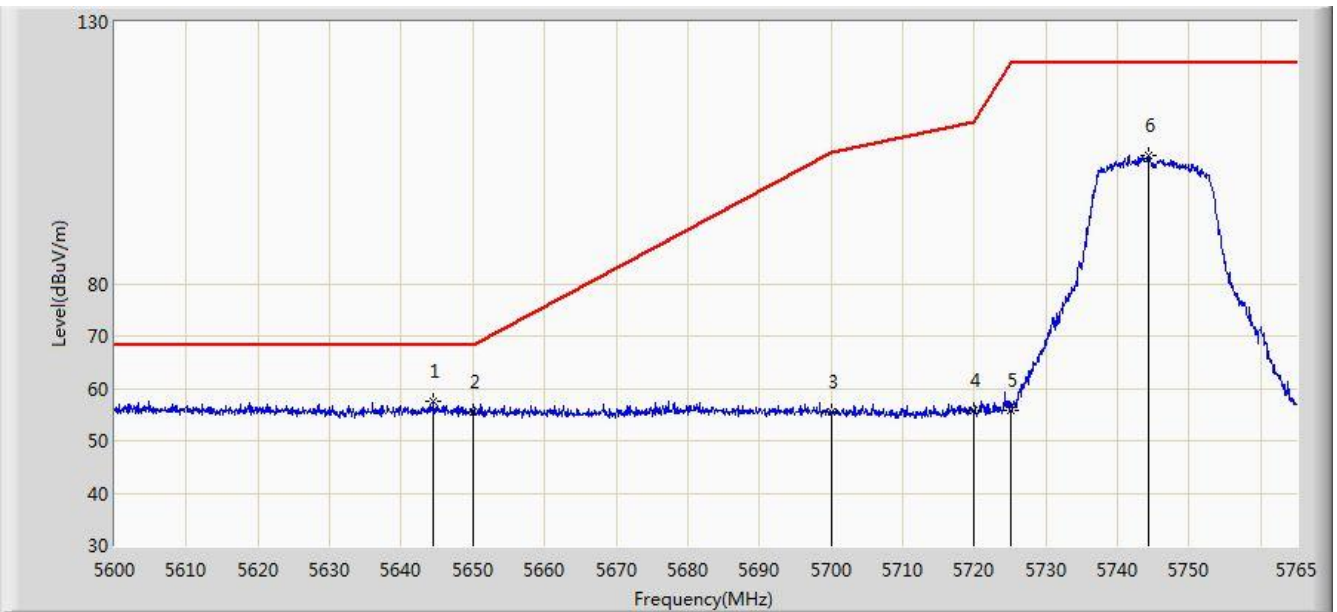

No	Flag	Mark	Frequency (MHz)	Measure Level (dBuV/m)	Reading Level (dBuV)	Over Limit (dB)	Limit (dBuV/m)	Factor (dB)	Type
1		*	5644.550	57.501	53.591	-10.699	68.200	3.910	PK
2			5650.000	55.441	51.638	-12.759	68.200	3.803	PK
3			5700.000	55.472	51.532	-49.728	105.200	3.940	PK
4			5720.000	55.788	51.806	-55.012	110.800	3.982	PK
5			5725.000	55.885	51.779	-66.315	122.200	4.105	PK
6			5744.375	104.384	100.114	N/A	N/A	4.270	PK

Note: Measure Level (dBμV/m) = Reading Level (dBμV) + Factor (dB)

Factor (dB) = Cable Loss (dB) + Antenna Factor (dB/m) - Pre\_Amplifier Gain (dB)

Site: AC2	Time: 2017/12/02 - 15:00
Limit: FCC_Part15.407_RE(3m)	Engineer: Snake Ni
Probe: BBHA9120D_1-18GHz	Polarity: Vertical
EUT: VR All-In-One Headset	Power: By Battery
Test Mode: Transmit by 802.11a at Channel 5745MHz Ant 0 + 1	

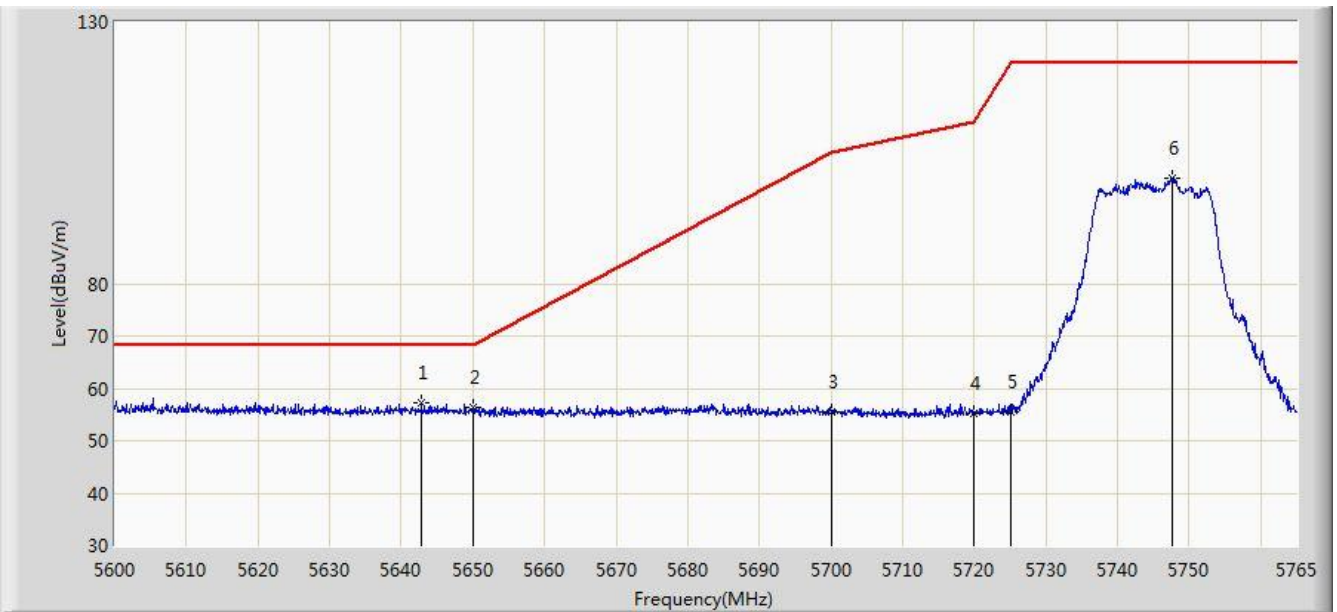

No	Flag	Mark	Frequency (MHz)	Measure Level (dBuV/m)	Reading Level (dBuV)	Over Limit (dB)	Limit (dBuV/m)	Factor (dB)	Type
1		*	5642.817	57.114	53.234	-11.086	68.200	3.879	PK
2			5650.000	56.316	52.513	-11.884	68.200	3.803	PK
3			5700.000	55.628	51.688	-49.572	105.200	3.940	PK
4			5720.000	55.305	51.323	-55.495	110.800	3.982	PK
5			5725.000	55.627	51.521	-66.573	122.200	4.105	PK
6			5747.592	100.138	95.870	N/A	N/A	4.268	PK

Note: Measure Level (dBμV/m) = Reading Level (dBμV) + Factor (dB)

Factor (dB) = Cable Loss (dB) + Antenna Factor (dB/m) - Pre\_Amplifier Gain (dB)

Site: AC2	Time: 2017/12/02 - 15:02
Limit: FCC_Part15.407_RE(3m)	Engineer: Snake Ni
Probe: BBHA9120D_1-18GHz	Polarity: Horizontal
EUT: VR All-In-One Headset	Power: By Battery
Test Mode: Transmit by 802.11a at Channel 5825MHz Ant 0 + 1	

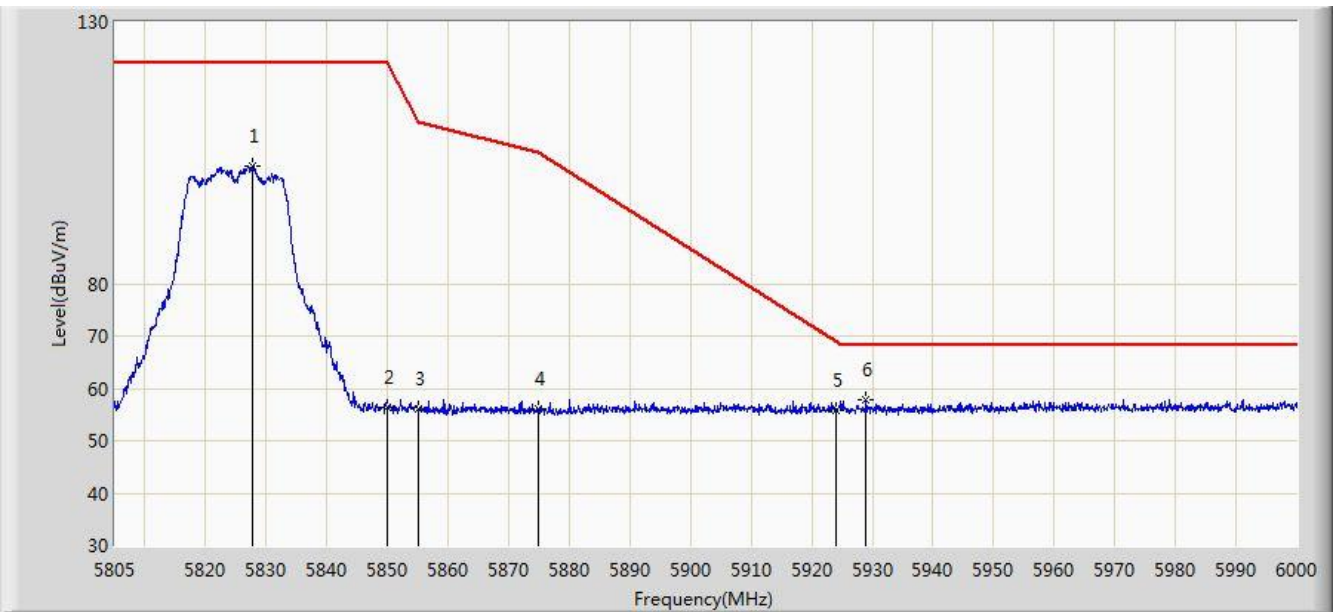

No	Flag	Mark	Frequency (MHz)	Measure Level (dBuV/m)	Reading Level (dBuV)	Over Limit (dB)	Limit (dBuV/m)	Factor (dB)	Type
1			5827.717	102.405	97.627	N/A	N/A	4.779	PK
2			5850.000	56.322	51.327	-65.878	122.200	4.995	PK
3			5855.000	56.129	51.141	-54.671	110.800	4.987	PK
4			5875.000	56.023	51.016	-49.177	105.200	5.008	PK
5			5924.000	55.906	50.753	-13.030	68.937	5.153	PK
6		*	5928.922	57.929	52.742	-10.271	68.200	5.187	PK

Note: Measure Level (dBμV/m) = Reading Level (dBμV) + Factor (dB)

Factor (dB) = Cable Loss (dB) + Antenna Factor (dB/m) - Pre\_Amplifier Gain (dB)

Site: AC2	Time: 2017/12/02 - 15:04
Limit: FCC_Part15.407_RE(3m)	Engineer: Snake Ni
Probe: BBHA9120D_1-18GHz	Polarity: Vertical
EUT: VR All-In-One Headset	Power: By Battery
Test Mode: Transmit by 802.11a at Channel 5825MHz Ant 0 + 1	

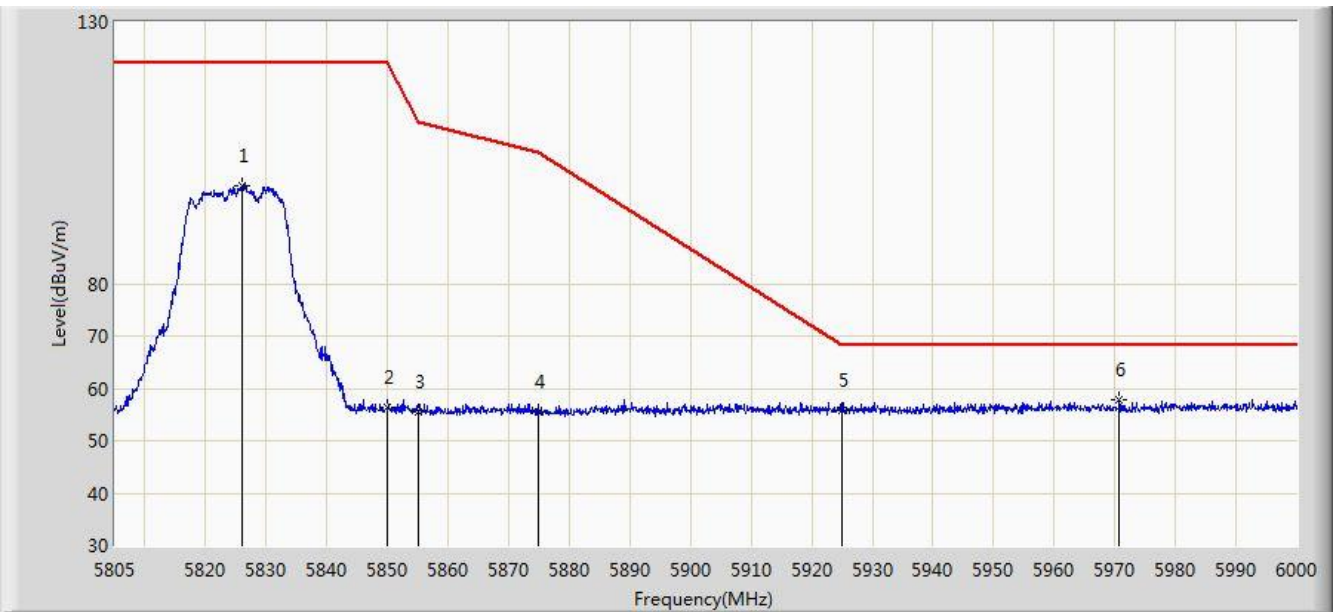

No	Flag	Mark	Frequency (MHz)	Measure Level (dBuV/m)	Reading Level (dBuV)	Over Limit (dB)	Limit (dBuV/m)	Factor (dB)	Type
1			5825.962	98.797	94.045	N/A	N/A	4.752	PK
2			5850.000	56.345	51.350	-65.855	122.200	4.995	PK
3			5855.000	55.459	50.471	-55.341	110.800	4.987	PK
4			5875.000	55.561	50.554	-49.639	105.200	5.008	PK
5			5925.000	55.807	50.655	-12.393	68.200	5.152	PK
6		*	5970.750	57.806	52.583	-10.394	68.200	5.222	PK

Note: Measure Level (dBμV/m) = Reading Level (dBμV) + Factor (dB)

Factor (dB) = Cable Loss (dB) + Antenna Factor (dB/m) - Pre\_Amplifier Gain (dB)

Site: AC2	Time: 2017/12/02 - 15:08
Limit: FCC_Part15.209_RE(3m)	Engineer: Snake Ni
Probe: BBHA9120D_1-18GHz	Polarity: Horizontal
EUT: VR All-In-One Headset	Power: By Battery
Test Mode: Transmit by 802.11n-HT20 at Channel 5180MHz Ant 0 + 1	

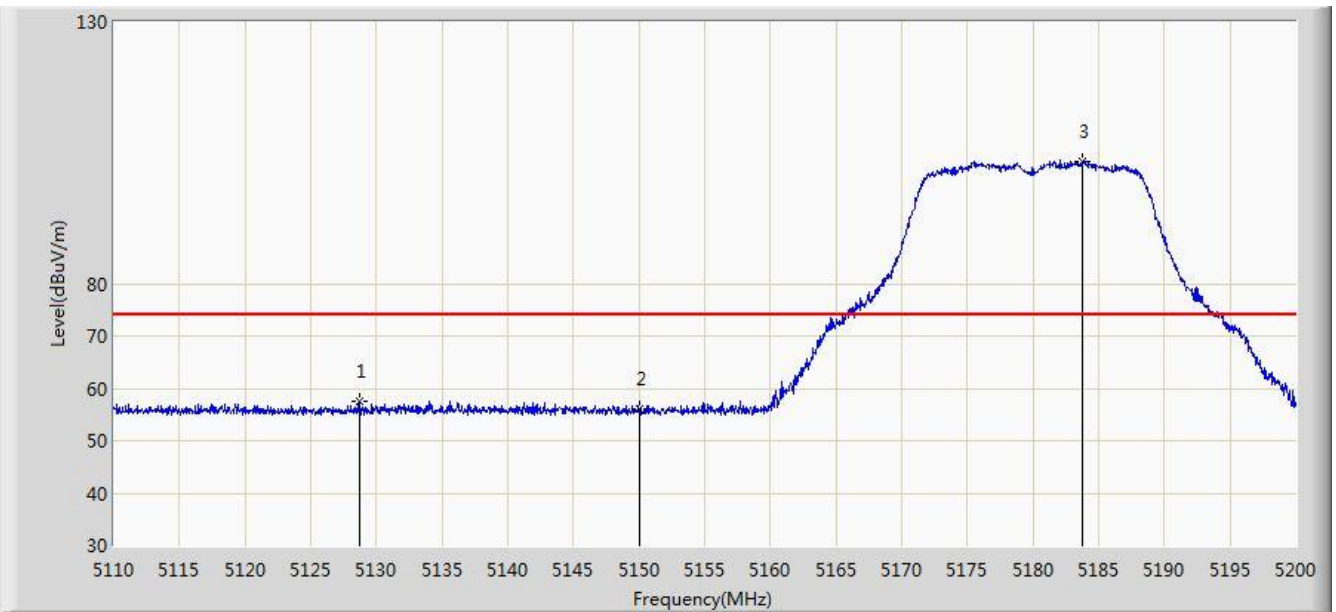

No	Flag	Mark	Frequency (MHz)	Measure Level (dBuV/m)	Reading Level (dBuV)	Over Limit (dB)	Limit (dBuV/m)	Factor (dB)	Type
1			5128.675	57.551	54.392	-16.449	74.000	3.159	PK
2			5150.000	56.041	52.971	-17.959	74.000	3.069	PK
3		*	5183.800	103.447	100.419	N/A	N/A	3.028	PK

Note: Measure Level (dB $\mu$ V/m) = Reading Level (dB $\mu$ V) + Factor (dB)

Factor (dB) = Cable Loss (dB) + Antenna Factor (dB/m) - Pre\_Amplifier Gain (dB)

Site: AC2	Time: 2017/12/02 - 15:10
Limit: FCC_Part15.209_RE(3m)	Engineer: Snake Ni
Probe: BBHA9120D_1-18GHz	Polarity: Horizontal
EUT: VR All-In-One Headset	Power: By Battery
Test Mode: Transmit by 802.11n-HT20 at Channel 5180MHz Ant 0 + 1	

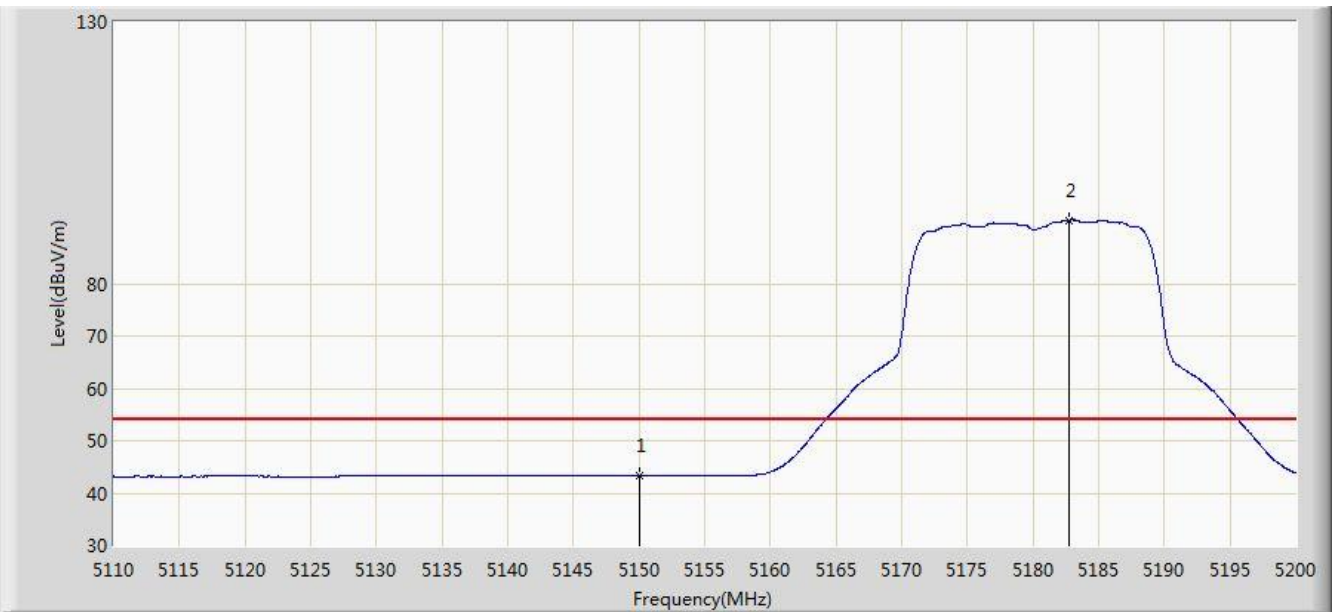

No	Flag	Mark	Frequency (MHz)	Measure Level (dBuV/m)	Reading Level (dBuV)	Over Limit (dB)	Limit (dBuV/m)	Factor (dB)	Type
1			5150.000	43.231	40.161	-10.769	54.000	3.069	AV
2		*	5182.720	92.122	89.080	N/A	N/A	3.043	AV

Note: Measure Level (dB $\mu$ V/m) = Reading Level (dB $\mu$ V) + Factor (dB)

Factor (dB) = Cable Loss (dB) + Antenna Factor (dB/m) - Pre\_Amplifier Gain (dB)

Site: AC2	Time: 2017/12/02 - 15:12
Limit: FCC_Part15.209_RE(3m)	Engineer: Snake Ni
Probe: BBHA9120D_1-18GHz	Polarity: Vertical
EUT: VR All-In-One Headset	Power: By Battery
Test Mode: Transmit by 802.11n-HT20 at Channel 5180MHz Ant 0 + 1	

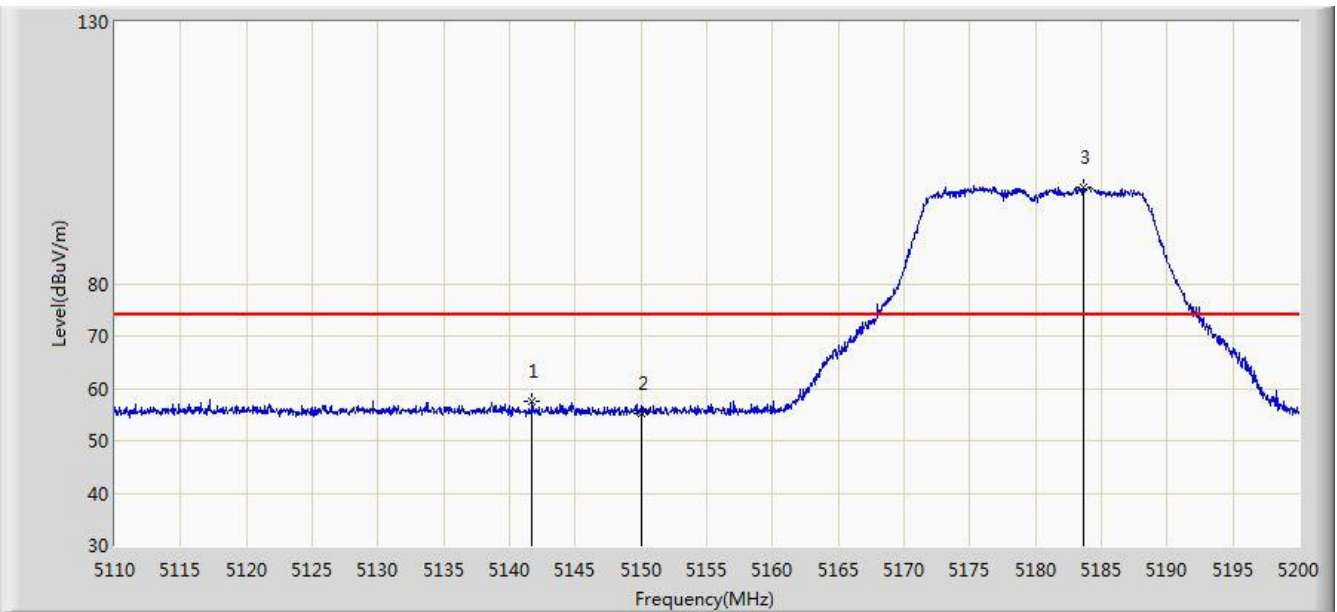

No	Flag	Mark	Frequency (MHz)	Measure Level (dBuV/m)	Reading Level (dBuV)	Over Limit (dB)	Limit (dBuV/m)	Factor (dB)	Type
1			5141.725	57.577	54.487	-16.423	74.000	3.090	PK
2			5150.000	55.304	52.234	-18.696	74.000	3.069	PK
3		*	5183.665	98.548	95.518	N/A	N/A	3.029	PK

Note: Measure Level (dB $\mu$ V/m) = Reading Level (dB $\mu$ V) + Factor (dB)

Factor (dB) = Cable Loss (dB) + Antenna Factor (dB/m) - Pre\_Amplifier Gain (dB)

Site: AC2	Time: 2017/12/02 - 15:14
Limit: FCC_Part15.209_RE(3m)	Engineer: Snake Ni
Probe: BBHA9120D_1-18GHz	Polarity: Vertical
EUT: VR All-In-One Headset	Power: By Battery
Test Mode: Transmit by 802.11n-HT20 at Channel 5180MHz Ant 0 + 1	

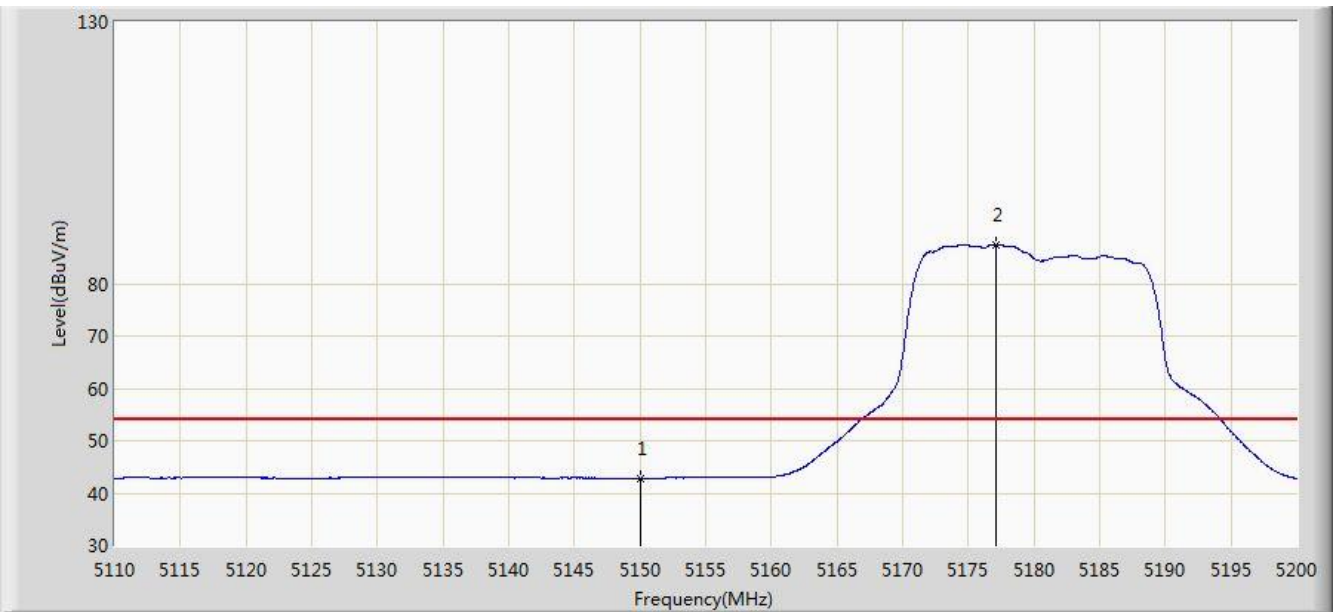

No	Flag	Mark	Frequency (MHz)	Measure Level (dBuV/m)	Reading Level (dBuV)	Over Limit (dB)	Limit (dBuV/m)	Factor (dB)	Type
1			5150.000	42.851	39.781	-11.149	54.000	3.069	AV
2		*	5177.140	87.431	84.399	N/A	N/A	3.032	AV

Note: Measure Level (dB $\mu$ V/m) = Reading Level (dB $\mu$ V) + Factor (dB)

Factor (dB) = Cable Loss (dB) + Antenna Factor (dB/m) - Pre\_Amplifier Gain (dB)



Site: AC2	Time: 2017/12/02 - 15:16
Limit: FCC_Part15.209_RE(3m)	Engineer: Snake Ni
Probe: BBHA9120D_1-18GHz	Polarity: Horizontal
EUT: VR All-In-One Headset	Power: By Battery
Test Mode: Transmit by 802.11n-HT20 at Channel 5320MHz Ant 0 + 1	

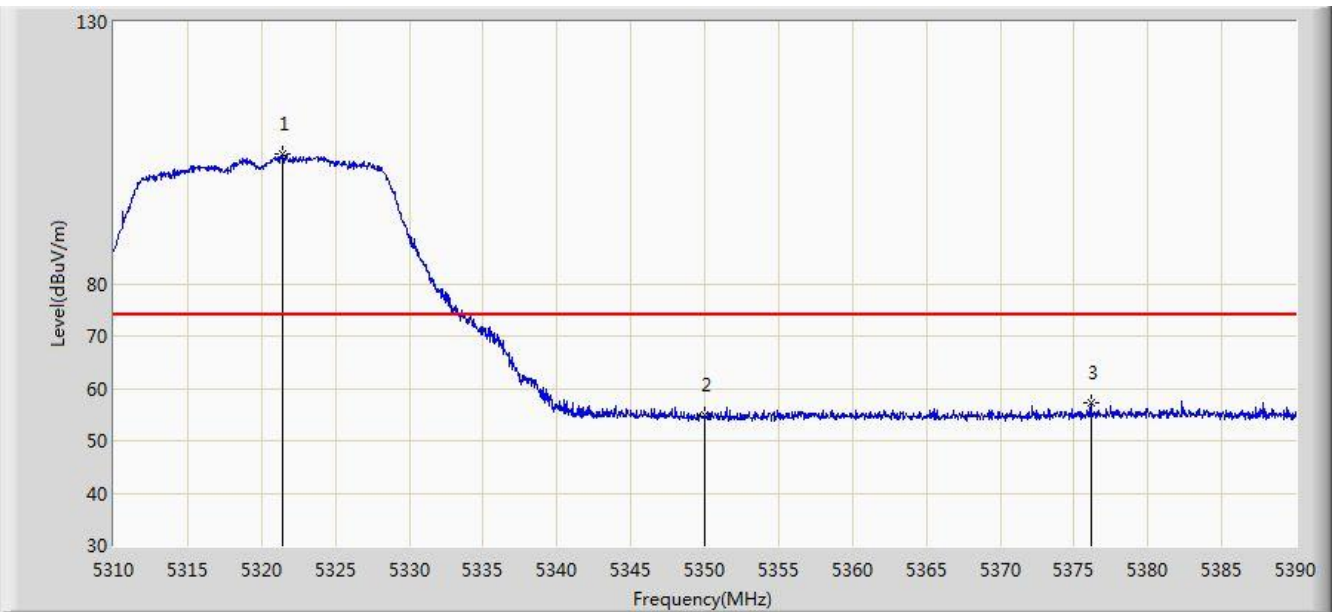

No	Flag	Mark	Frequency (MHz)	Measure Level (dBuV/m)	Reading Level (dBuV)	Over Limit (dB)	Limit (dBuV/m)	Factor (dB)	Type
1		*	5321.400	104.795	102.127	N/A	N/A	2.668	PK
2			5350.000	54.944	52.247	-19.056	74.000	2.697	PK
3			5376.120	57.192	54.199	-16.808	74.000	2.992	PK

Note: Measure Level (dBμV/m) = Reading Level (dBμV) + Factor (dB)

Factor (dB) = Cable Loss (dB) + Antenna Factor (dB/m) - Pre\_Amplifier Gain (dB)

Site: AC2	Time: 2017/12/02 - 15:18
Limit: FCC_Part15.209_RE(3m)	Engineer: Snake Ni
Probe: BBHA9120D_1-18GHz	Polarity: Horizontal
EUT: VR All-In-One Headset	Power: By Battery
Test Mode: Transmit by 802.11n-HT20 at Channel 5320MHz Ant 0 + 1	

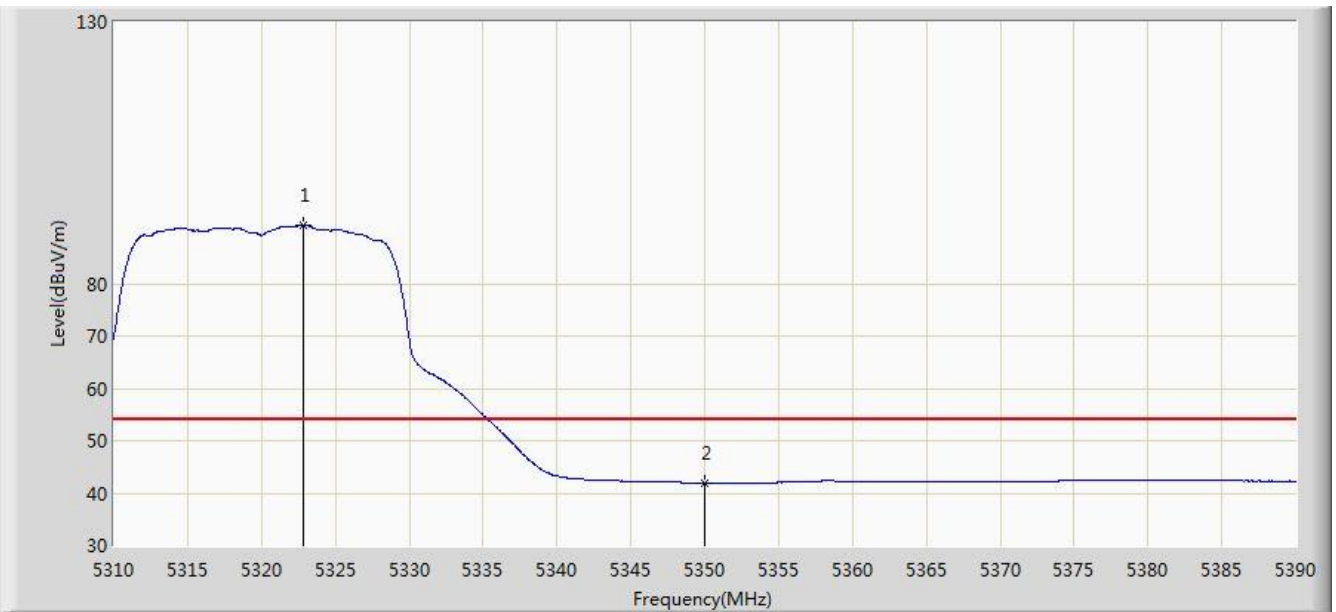

No	Flag	Mark	Frequency (MHz)	Measure Level (dBuV/m)	Reading Level (dBuV)	Over Limit (dB)	Limit (dBuV/m)	Factor (dB)	Type
1		*	5322.880	91.119	88.444	N/A	N/A	2.675	AV
2			5350.000	41.940	39.243	-12.060	54.000	2.697	AV

Note: Measure Level (dBμV/m) = Reading Level (dBμV) + Factor (dB)

Factor (dB) = Cable Loss (dB) + Antenna Factor (dB/m) - Pre\_Amplifier Gain (dB)

Site: AC2	Time: 2017/12/02 - 15:19
Limit: FCC_Part15.209_RE(3m)	Engineer: Snake Ni
Probe: BBHA9120D_1-18GHz	Polarity: Vertical
EUT: VR All-In-One Headset	Power: By Battery
Test Mode: Transmit by 802.11n-HT20 at Channel 5320MHz Ant 0 + 1	

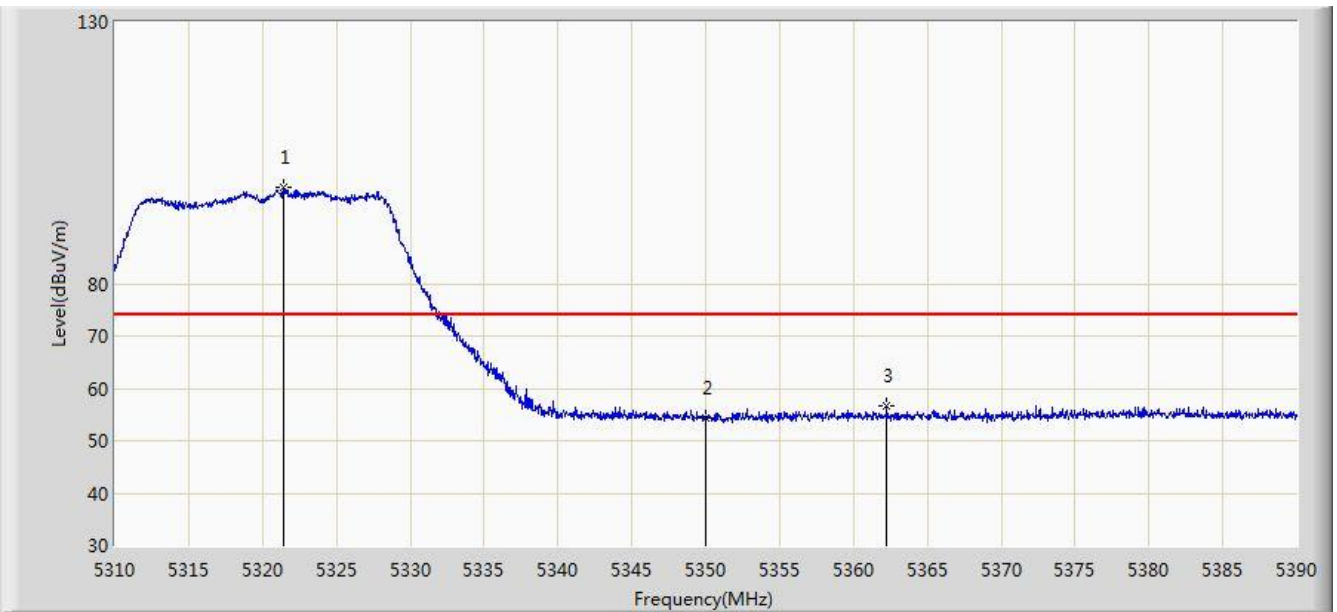

No	Flag	Mark	Frequency (MHz)	Measure Level (dBuV/m)	Reading Level (dBuV)	Over Limit (dB)	Limit (dBuV/m)	Factor (dB)	Type
1		*	5321.440	98.323	95.655	N/A	N/A	2.668	PK
2			5350.000	54.327	51.630	-19.673	74.000	2.697	PK
3			5362.280	56.556	53.830	-17.444	74.000	2.726	PK

Note: Measure Level (dB $\mu$ V/m) = Reading Level (dB $\mu$ V) + Factor (dB)

Factor (dB) = Cable Loss (dB) + Antenna Factor (dB/m) - Pre\_Amplifier Gain (dB)

Site: AC2	Time: 2017/12/02 - 15:21
Limit: FCC_Part15.209_RE(3m)	Engineer: Snake Ni
Probe: BBHA9120D_1-18GHz	Polarity: Vertical
EUT: VR All-In-One Headset	Power: By Battery
Test Mode: Transmit by 802.11n-HT20 at Channel 5320MHz Ant 0 + 1	

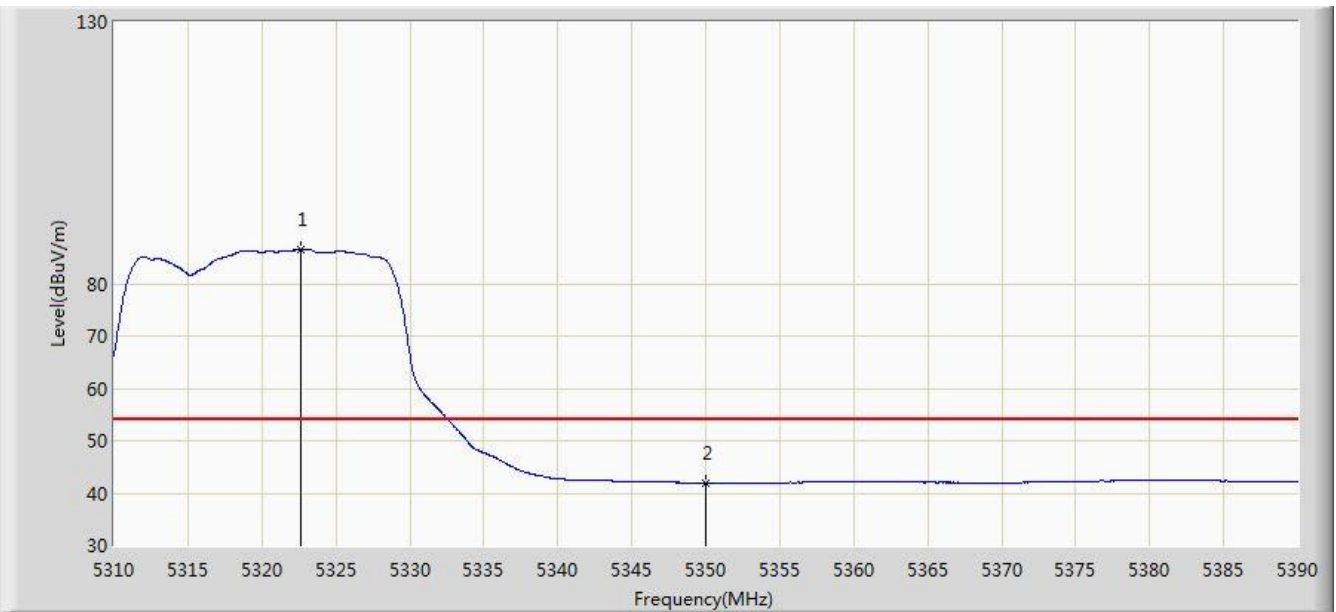

No	Flag	Mark	Frequency (MHz)	Measure Level (dBuV/m)	Reading Level (dBuV)	Over Limit (dB)	Limit (dBuV/m)	Factor (dB)	Type
1		*	5322.640	86.494	83.820	N/A	N/A	2.674	AV
2			5350.000	41.880	39.183	-12.120	54.000	2.697	AV

Note: Measure Level (dB $\mu$ V/m) = Reading Level (dB $\mu$ V) + Factor (dB)

Factor (dB) = Cable Loss (dB) + Antenna Factor (dB/m) - Pre\_Amplifier Gain (dB)

Site: AC2	Time: 2017/12/02 - 15:24
Limit: FCC_Part15.209_RE(3m)	Engineer: Snake Ni
Probe: BBHA9120D_1-18GHz	Polarity: Horizontal
EUT: VR All-In-One Headset	Power: By Battery
Test Mode: Transmit by 802.11n-HT20 at Channel 5500MHz Ant 0 + 1	

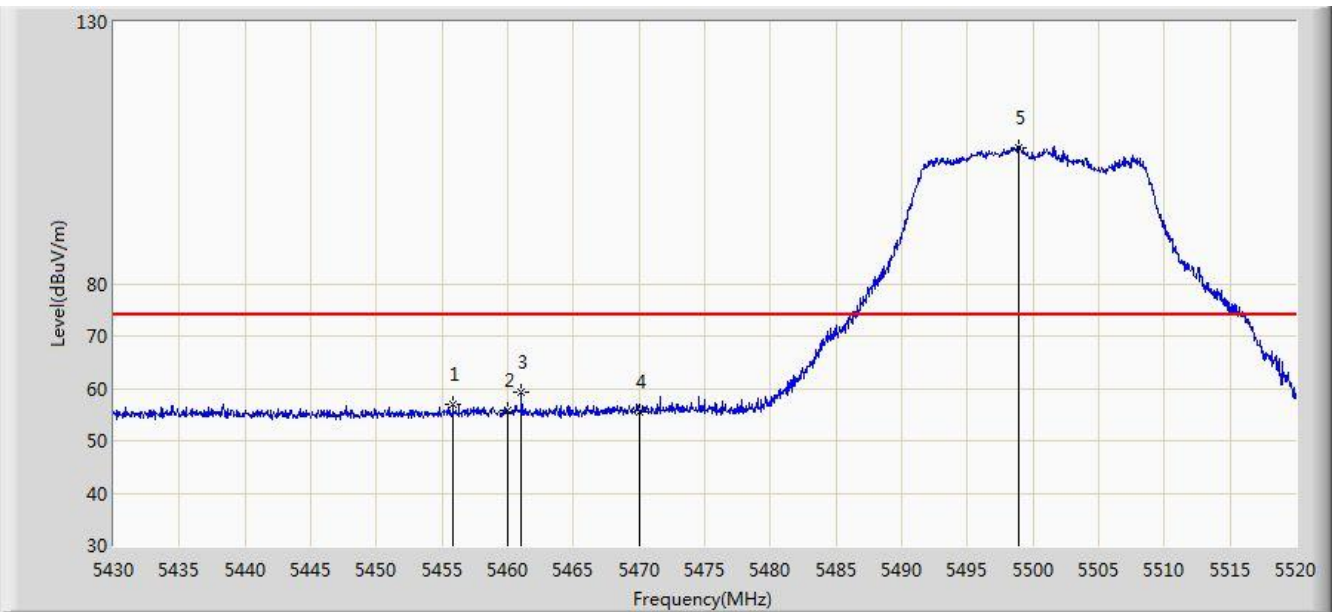

No	Flag	Mark	Frequency (MHz)	Measure Level (dBuV/m)	Reading Level (dBuV)	Over Limit (dB)	Limit (dBuV/m)	Factor (dB)	Type
1			5455.830	57.028	53.975	-16.972	74.000	3.053	PK
2			5460.000	55.754	52.561	-18.246	74.000	3.194	PK
3			5461.050	59.176	55.947	-14.824	74.000	3.229	PK
4			5470.000	55.632	52.103	-18.368	74.000	3.529	PK
5		*	5498.940	105.934	102.810	N/A	N/A	3.124	PK

Note: Measure Level (dBμV/m) = Reading Level (dBμV) + Factor (dB)

Factor (dB) = Cable Loss (dB) + Antenna Factor (dB/m) - Pre\_Amplifier Gain (dB)

Site: AC2	Time: 2017/12/02 - 15:25
Limit: FCC_Part15.209_RE(3m)	Engineer: Snake Ni
Probe: BBHA9120D_1-18GHz	Polarity: Horizontal
EUT: VR All-In-One Headset	Power: By Battery
Test Mode: Transmit by 802.11n-HT20 at Channel 5500MHz Ant 0 + 1	

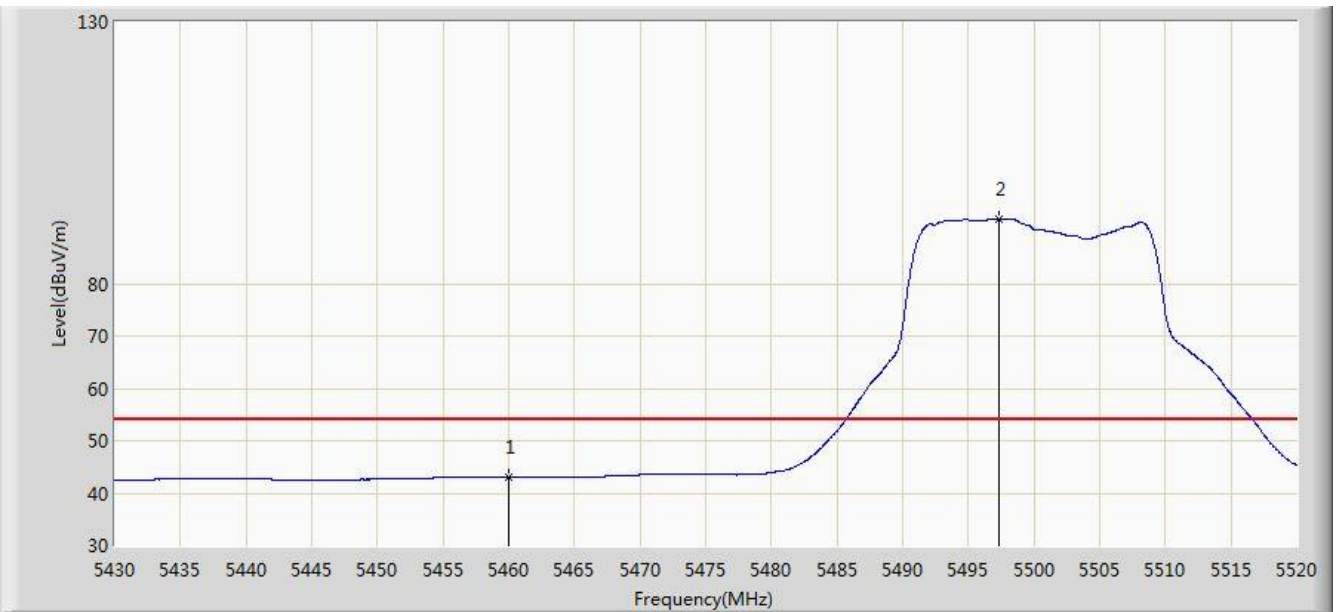

No	Flag	Mark	Frequency (MHz)	Measure Level (dBuV/m)	Reading Level (dBuV)	Over Limit (dB)	Limit (dBuV/m)	Factor (dB)	Type
1			5460.000	43.081	39.888	-10.919	54.000	3.194	AV
2		*	5497.275	92.453	89.313	N/A	N/A	3.140	AV

Note: Measure Level (dB $\mu$ V/m) = Reading Level (dB $\mu$ V) + Factor (dB)

Factor (dB) = Cable Loss (dB) + Antenna Factor (dB/m) - Pre\_Amplifier Gain (dB)

Site: AC2	Time: 2017/12/02 - 15:26
Limit: FCC_Part15.209_RE(3m)	Engineer: Snake Ni
Probe: BBHA9120D_1-18GHz	Polarity: Vertical
EUT: VR All-In-One Headset	Power: By Battery
Test Mode: Transmit by 802.11n-HT20 at Channel 5500MHz Ant 0 + 1	

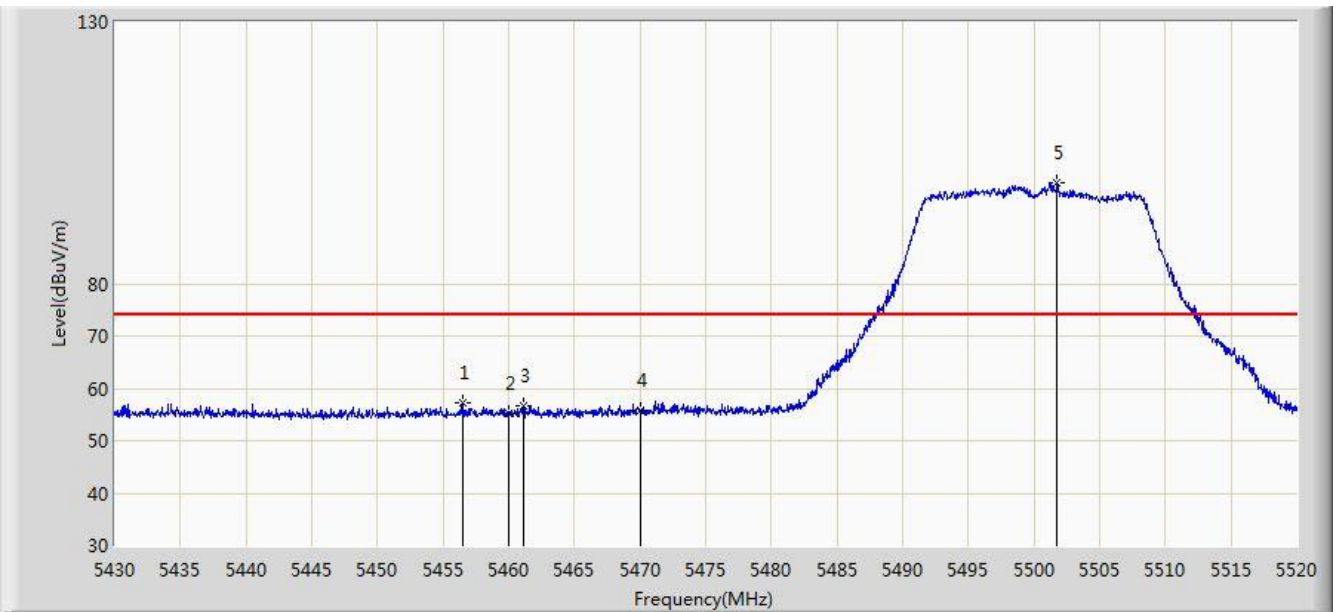

No	Flag	Mark	Frequency (MHz)	Measure Level (dBuV/m)	Reading Level (dBuV)	Over Limit (dB)	Limit (dBuV/m)	Factor (dB)	Type
1			5456.460	57.259	54.185	-16.741	74.000	3.074	PK
2			5460.000	55.203	52.010	-18.797	74.000	3.194	PK
3			5461.095	56.673	53.443	-17.327	74.000	3.230	PK
4			5470.000	55.669	52.140	-18.331	74.000	3.529	PK
5		*	5501.730	99.205	96.108	N/A	N/A	3.097	PK

Note: Measure Level (dBuV/m) = Reading Level (dBuV) + Factor (dB)

Factor (dB) = Cable Loss (dB) + Antenna Factor (dB/m) - Pre\_Amplifier Gain (dB)

Site: AC2	Time: 2017/12/02 - 15:28
Limit: FCC_Part15.209_RE(3m)	Engineer: Snake Ni
Probe: BBHA9120D_1-18GHz	Polarity: Vertical
EUT: VR All-In-One Headset	Power: By Battery
Test Mode: Transmit by 802.11n-HT20 at Channel 5500MHz Ant 0 + 1	

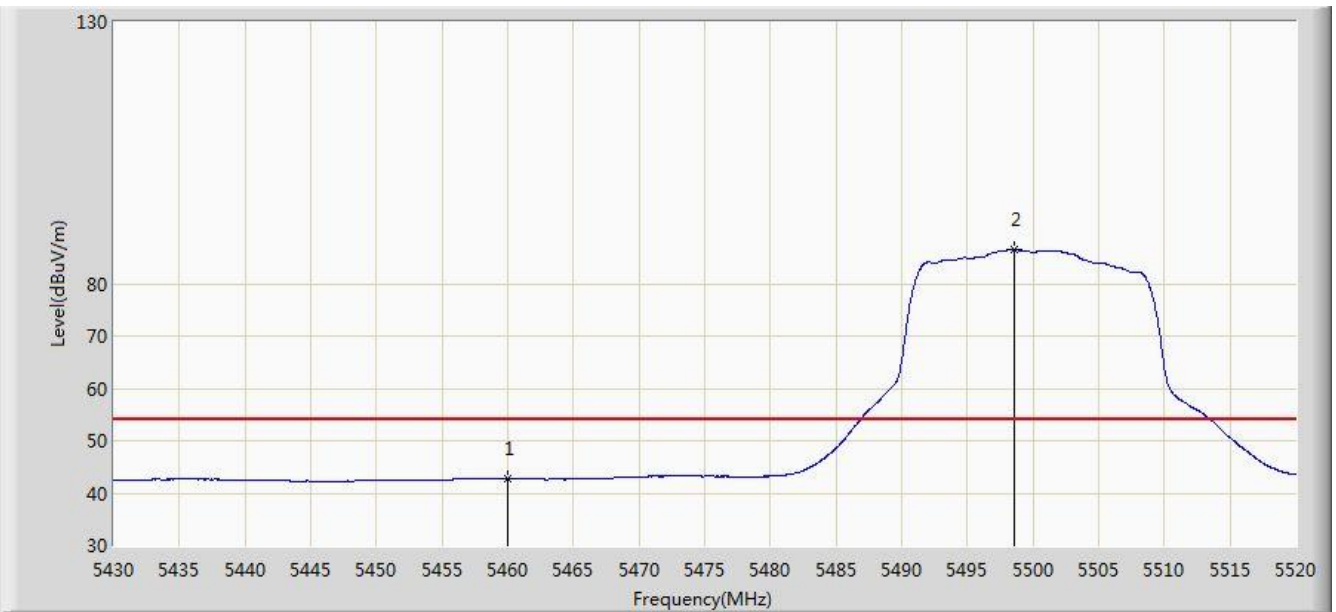

No	Flag	Mark	Frequency (MHz)	Measure Level (dBuV/m)	Reading Level (dBuV)	Over Limit (dB)	Limit (dBuV/m)	Factor (dB)	Type
1			5460.000	42.696	39.503	-11.304	54.000	3.194	AV
2		*	5498.535	86.654	83.526	N/A	N/A	3.127	AV

Note: Measure Level (dBμV/m) = Reading Level (dBμV) + Factor (dB)

Factor (dB) = Cable Loss (dB) + Antenna Factor (dB/m) - Pre\_Amplifier Gain (dB)



Site: AC2	Time: 2017/12/02 - 15:29
Limit: FCC_Part15.209_RE(3m)	Engineer: Snake Ni
Probe: BBHA9120D_1-18GHz	Polarity: Horizontal
EUT: VR All-In-One Headset	Power: By Battery
Test Mode: Transmit by 802.11n-HT20 at Channel 5700MHz Ant 0 + 1	

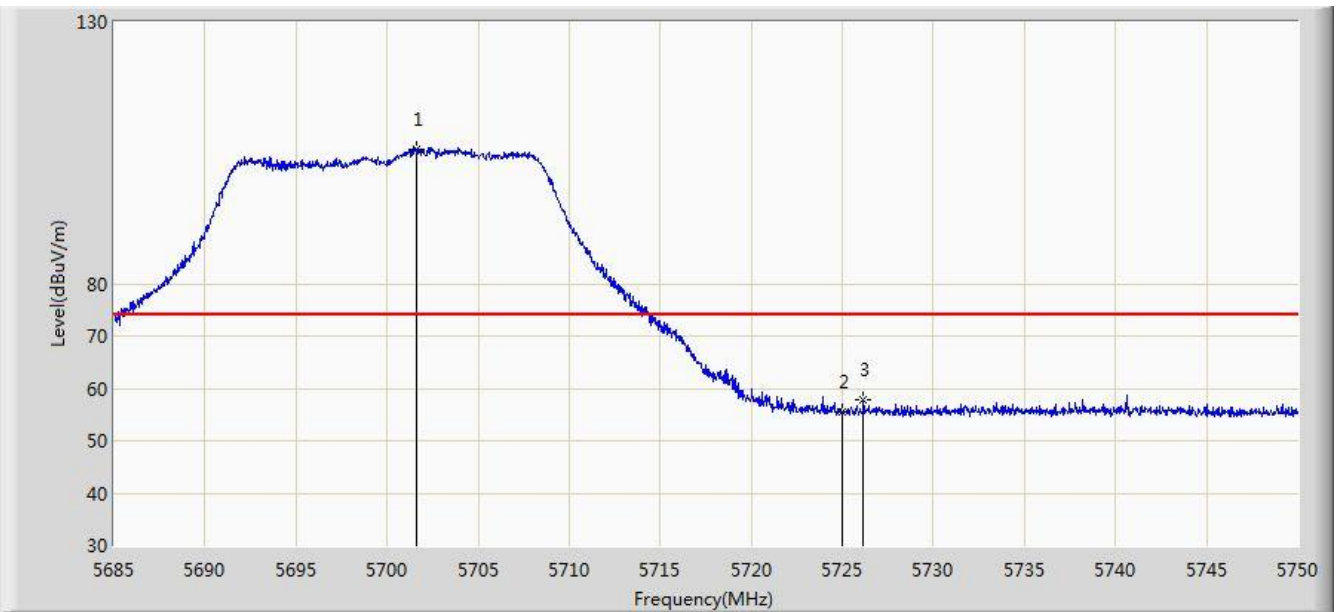

No	Flag	Mark	Frequency (MHz)	Measure Level (dBuV/m)	Reading Level (dBuV)	Over Limit (dB)	Limit (dBuV/m)	Factor (dB)	Type
1		*	5701.607	105.661	101.739	N/A	N/A	3.922	PK
2			5725.000	55.453	51.347	-18.547	74.000	4.105	PK
3			5726.145	57.887	53.753	-16.113	74.000	4.133	PK

Note: Measure Level (dB $\mu$ V/m) = Reading Level (dB $\mu$ V) + Factor (dB)

Factor (dB) = Cable Loss (dB) + Antenna Factor (dB/m) - Pre\_Amplifier Gain (dB)

Site: AC2	Time: 2017/12/02 - 15:31
Limit: FCC_Part15.209_RE(3m)	Engineer: Snake Ni
Probe: BBHA9120D_1-18GHz	Polarity: Horizontal
EUT: VR All-In-One Headset	Power: By Battery
Test Mode: Transmit by 802.11n-HT20 at Channel 5700MHz Ant 0 + 1	

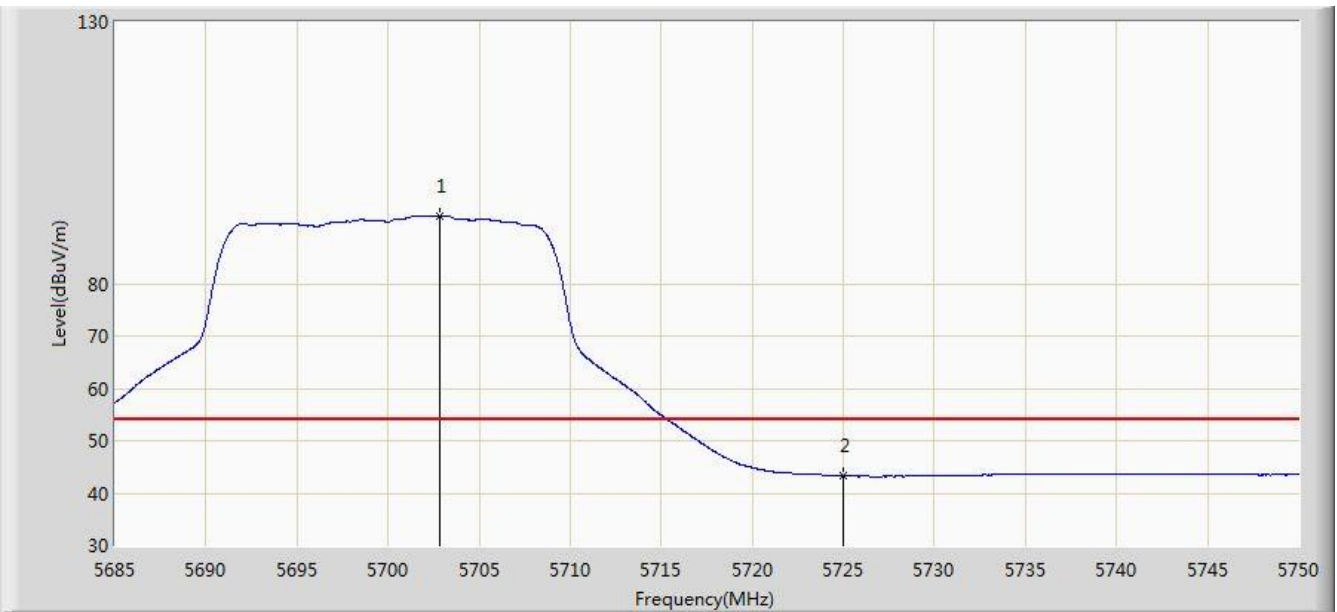

No	Flag	Mark	Frequency (MHz)	Measure Level (dBuV/m)	Reading Level (dBuV)	Over Limit (dB)	Limit (dBuV/m)	Factor (dB)	Type
1		*	5702.842	92.959	89.050	N/A	N/A	3.909	AV
2			5725.000	43.276	39.170	-10.724	54.000	4.105	AV

Note: Measure Level (dB $\mu$ V/m) = Reading Level (dB $\mu$ V) + Factor (dB)

Factor (dB) = Cable Loss (dB) + Antenna Factor (dB/m) - Pre\_Amplifier Gain (dB)

Site: AC2	Time: 2017/12/02 - 15:32
Limit: FCC_Part15.209_RE(3m)	Engineer: Snake Ni
Probe: BBHA9120D_1-18GHz	Polarity: Vertical
EUT: VR All-In-One Headset	Power: By Battery
Test Mode: Transmit by 802.11n-HT20 at Channel 5700MHz Ant 0 + 1	

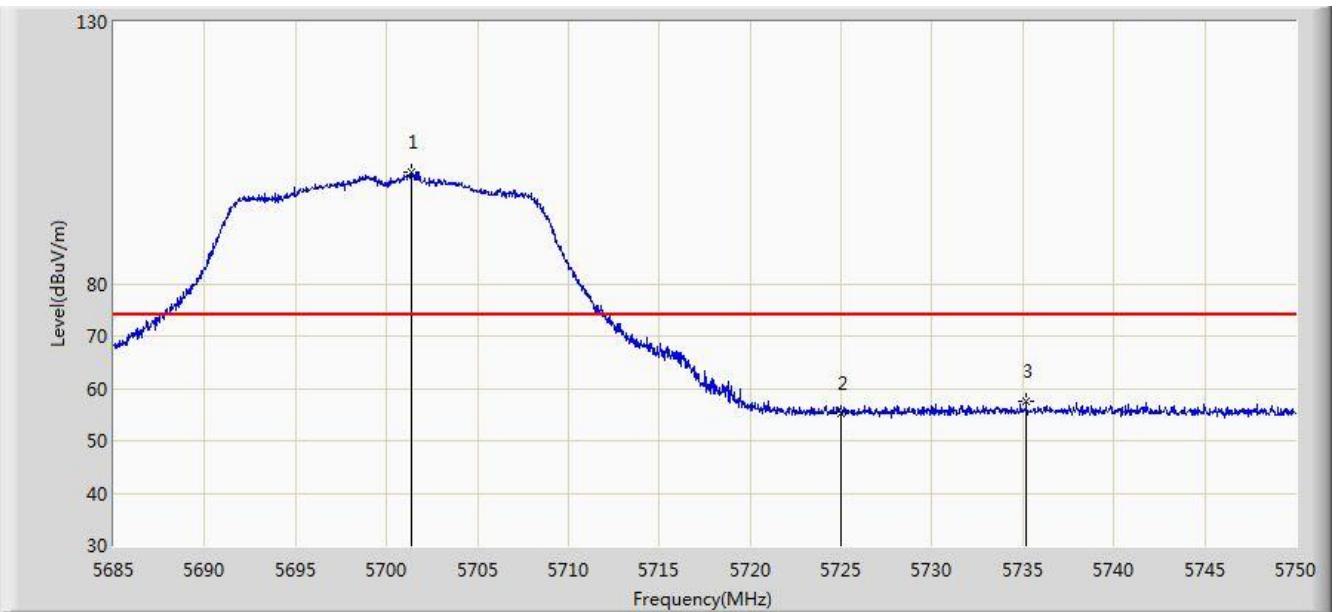

No	Flag	Mark	Frequency (MHz)	Measure Level (dBuV/m)	Reading Level (dBuV)	Over Limit (dB)	Limit (dBuV/m)	Factor (dB)	Type
1		*	5701.380	101.387	97.462	N/A	N/A	3.925	PK
2			5725.000	55.343	51.237	-18.657	74.000	4.105	PK
3			5735.180	57.565	53.276	-16.435	74.000	4.288	PK

Note: Measure Level (dBμV/m) = Reading Level (dBμV) + Factor (dB)

Factor (dB) = Cable Loss (dB) + Antenna Factor (dB/m) - Pre\_Amplifier Gain (dB)

Site: AC2	Time: 2017/12/02 - 15:34
Limit: FCC_Part15.209_RE(3m)	Engineer: Snake Ni
Probe: BBHA9120D_1-18GHz	Polarity: Vertical
EUT: VR All-In-One Headset	Power: By Battery
Test Mode: Transmit by 802.11n-HT20 at Channel 5700MHz Ant 0 + 1	

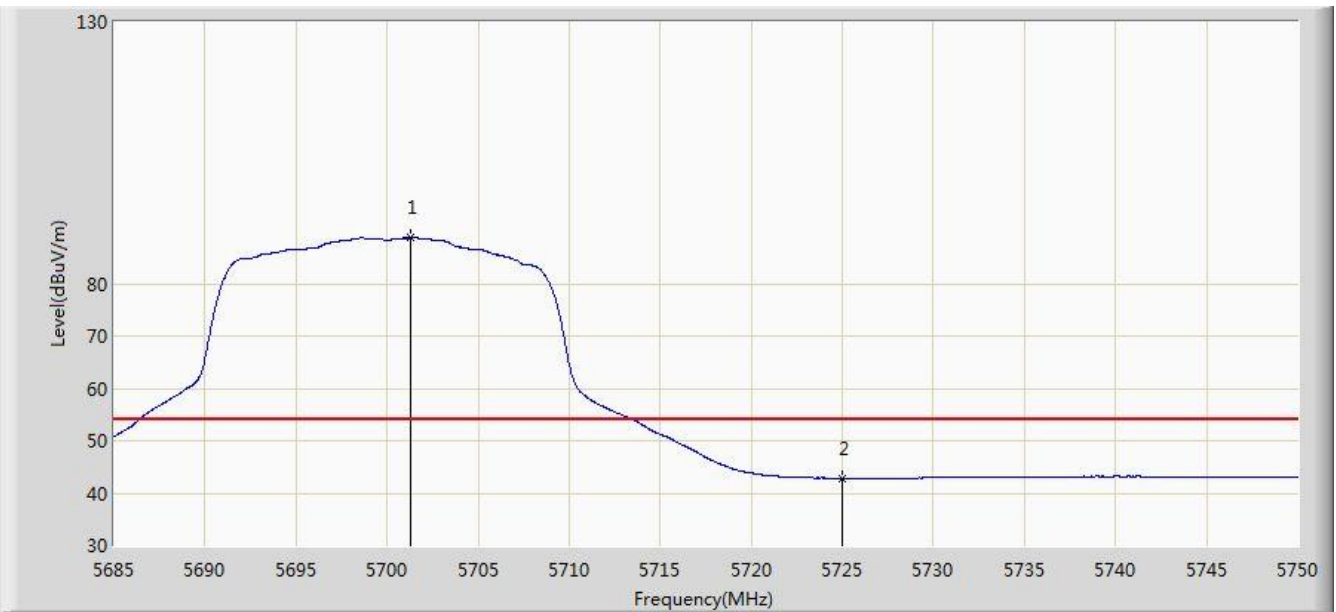

No	Flag	Mark	Frequency (MHz)	Measure Level (dBuV/m)	Reading Level (dBuV)	Over Limit (dB)	Limit (dBuV/m)	Factor (dB)	Type
1		*	5701.250	88.774	84.848	N/A	N/A	3.927	AV
2			5725.000	42.834	38.728	-11.166	54.000	4.105	AV

Note: Measure Level (dB $\mu$ V/m) = Reading Level (dB $\mu$ V) + Factor (dB)

Factor (dB) = Cable Loss (dB) + Antenna Factor (dB/m) - Pre\_Amplifier Gain (dB)

Site: AC2	Time: 2017/12/02 - 15:35
Limit: FCC_Part15.407_RE(3m)	Engineer: Snake Ni
Probe: BBHA9120D_1-18GHz	Polarity: Horizontal
EUT: VR All-In-One Headset	Power: By Battery
Test Mode: Transmit by 802.11n-HT20 at Channel 5745MHz Ant 0 + 1	

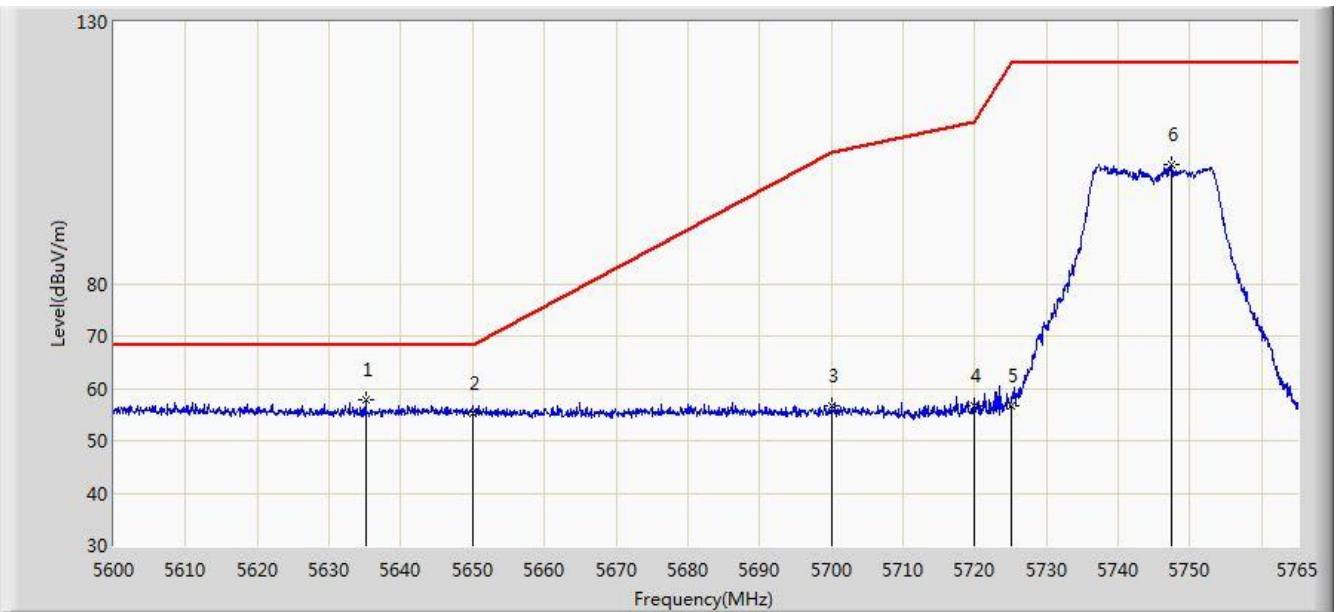

No	Flag	Mark	Frequency (MHz)	Measure Level (dBuV/m)	Reading Level (dBuV)	Over Limit (dB)	Limit (dBuV/m)	Factor (dB)	Type
1		*	5635.062	57.909	54.188	-10.291	68.200	3.721	PK
2			5650.000	55.247	51.444	-12.953	68.200	3.803	PK
3			5700.000	56.535	52.595	-48.665	105.200	3.940	PK
4			5720.000	56.525	52.543	-54.275	110.800	3.982	PK
5			5725.000	56.646	52.540	-65.554	122.200	4.105	PK
6			5747.510	102.709	98.441	N/A	N/A	4.268	PK

Note: Measure Level (dBμV/m) = Reading Level (dBμV) + Factor (dB)

Factor (dB) = Cable Loss (dB) + Antenna Factor (dB/m) - Pre\_Amplifier Gain (dB)

Site: AC2	Time: 2017/12/02 - 15:37
Limit: FCC_Part15.407_RE(3m)	Engineer: Snake Ni
Probe: BBHA9120D_1-18GHz	Polarity: Vertical
EUT: VR All-In-One Headset	Power: By Battery
Test Mode: Transmit by 802.11n-HT20 at Channel 5745MHz Ant 0 + 1	

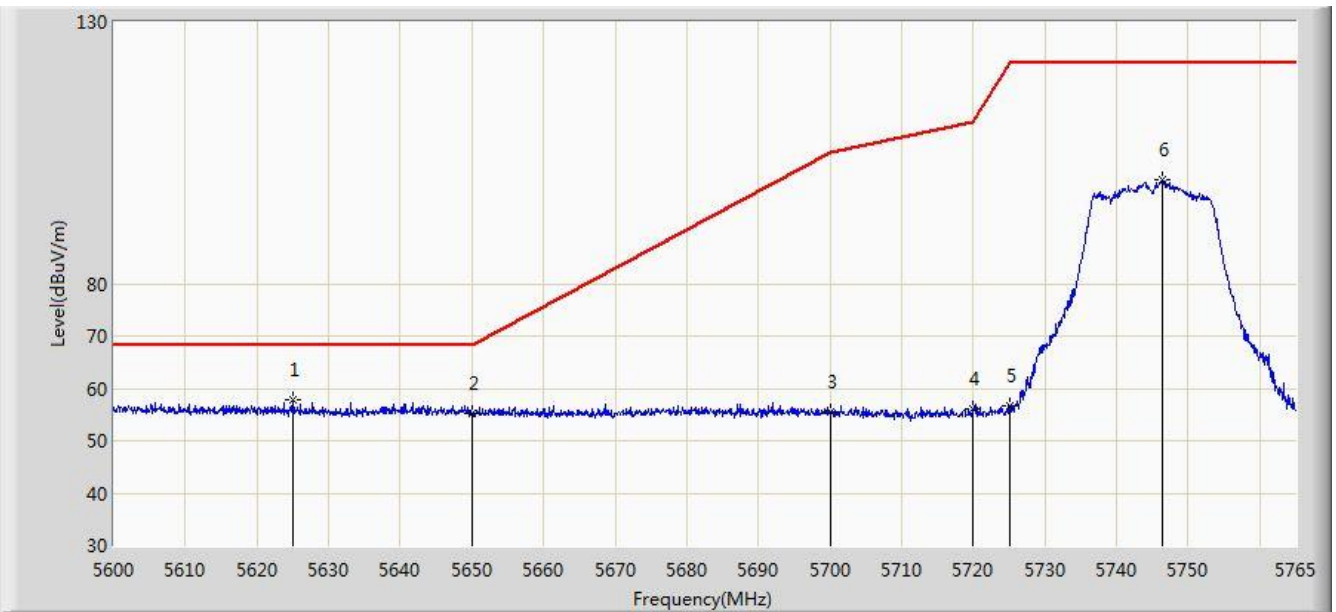

No	Flag	Mark	Frequency (MHz)	Measure Level (dBuV/m)	Reading Level (dBuV)	Over Limit (dB)	Limit (dBuV/m)	Factor (dB)	Type
1		*	5624.998	57.756	54.186	-10.444	68.200	3.570	PK
2			5650.000	55.241	51.438	-12.959	68.200	3.803	PK
3			5700.000	55.496	51.556	-49.704	105.200	3.940	PK
4			5720.000	56.091	52.109	-54.709	110.800	3.982	PK
5			5725.000	56.660	52.554	-65.540	122.200	4.105	PK
6			5746.437	99.919	95.651	N/A	N/A	4.268	PK

Note: Measure Level (dBμV/m) = Reading Level (dBμV) + Factor (dB)

Factor (dB) = Cable Loss (dB) + Antenna Factor (dB/m) - Pre\_Amplifier Gain (dB)

Site: AC2	Time: 2017/12/02 - 15:38
Limit: FCC_Part15.407_RE(3m)	Engineer: Snake Ni
Probe: BBHA9120D_1-18GHz	Polarity: Horizontal
EUT: VR All-In-One Headset	Power: By Battery
Test Mode: Transmit by 802.11n-HT20 at Channel 5825MHz Ant 0 + 1	

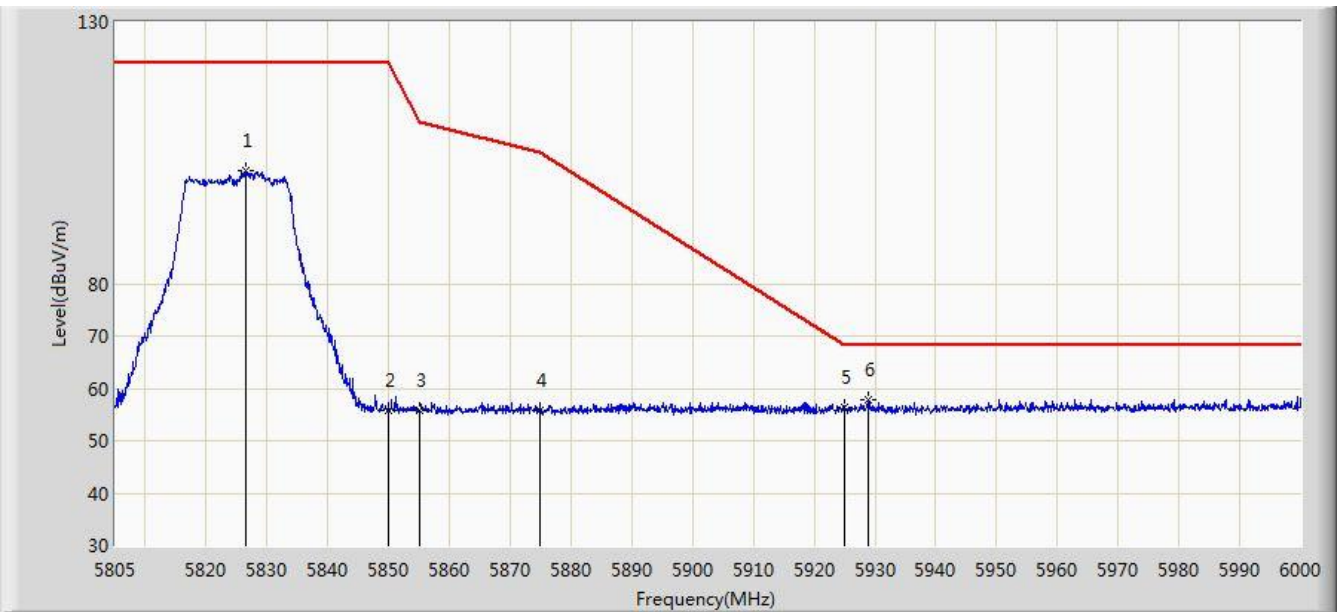

No	Flag	Mark	Frequency (MHz)	Measure Level (dBuV/m)	Reading Level (dBuV)	Over Limit (dB)	Limit (dBuV/m)	Factor (dB)	Type
1			5826.450	101.518	96.758	N/A	N/A	4.760	PK
2			5850.000	55.836	50.841	-66.364	122.200	4.995	PK
3			5855.000	55.678	50.690	-55.122	110.800	4.987	PK
4			5875.000	55.705	50.698	-49.495	105.200	5.008	PK
5			5925.000	56.233	51.081	-11.967	68.200	5.152	PK
6		*	5928.825	57.865	52.679	-10.335	68.200	5.186	PK

Note: Measure Level (dBμV/m) = Reading Level (dBμV) + Factor (dB)

Factor (dB) = Cable Loss (dB) + Antenna Factor (dB/m) - Pre\_Amplifier Gain (dB)

Site: AC2	Time: 2017/12/02 - 15:41
Limit: FCC_Part15.407_RE(3m)	Engineer: Snake Ni
Probe: BBHA9120D_1-18GHz	Polarity: Vertical
EUT: VR All-In-One Headset	Power: By Battery
Test Mode: Transmit by 802.11n-HT20 at Channel 5825MHz Ant 0 + 1	

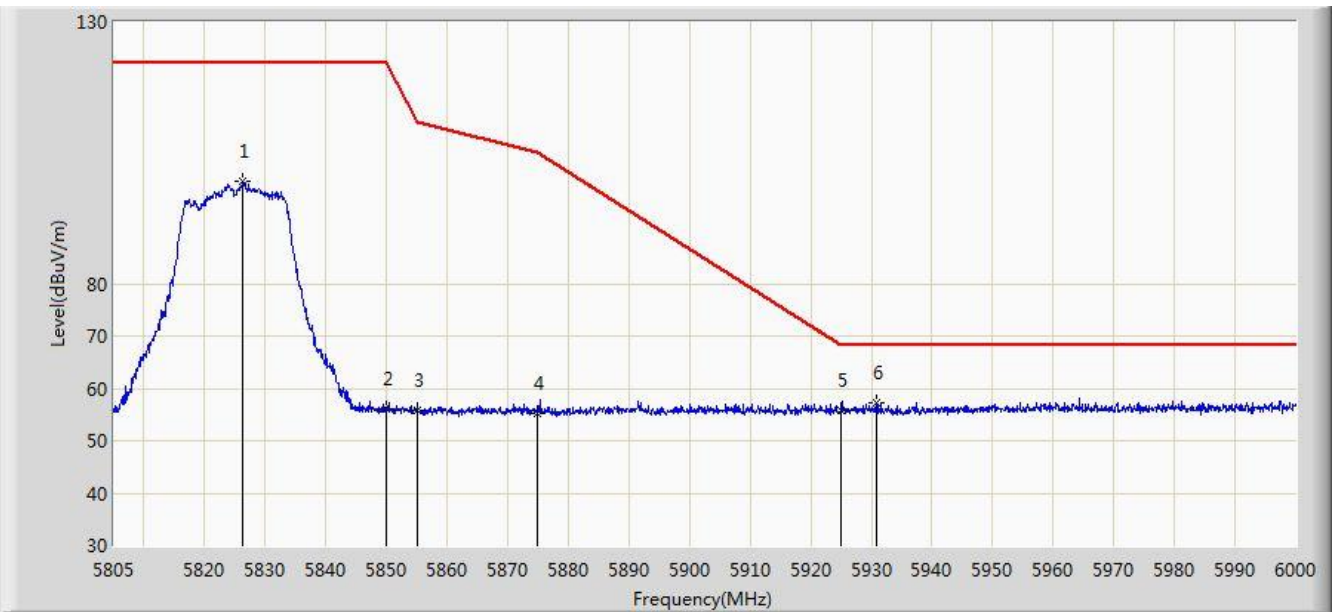

No	Flag	Mark	Frequency (MHz)	Measure Level (dBuV/m)	Reading Level (dBuV)	Over Limit (dB)	Limit (dBuV/m)	Factor (dB)	Type
1			5826.255	99.463	94.706	N/A	N/A	4.757	PK
2			5850.000	56.125	51.130	-66.075	122.200	4.995	PK
3			5855.000	55.911	50.923	-54.889	110.800	4.987	PK
4			5875.000	55.285	50.278	-49.915	105.200	5.008	PK
5			5925.000	55.703	50.551	-12.497	68.200	5.152	PK
6		*	5930.775	57.372	52.178	-10.828	68.200	5.195	PK

Note: Measure Level (dBμV/m) = Reading Level (dBμV) + Factor (dB)

Factor (dB) = Cable Loss (dB) + Antenna Factor (dB/m) - Pre\_Amplifier Gain (dB)



Site: AC2	Time: 2017/12/02 - 15:42
Limit: FCC_Part15.209_RE(3m)	Engineer: Snake Ni
Probe: BBHA9120D_1-18GHz	Polarity: Horizontal
EUT: VR All-In-One Headset	Power: By Battery
Test Mode: Transmit by 802.11n-HT40 at Channel 5190MHz Ant 0 + 1	

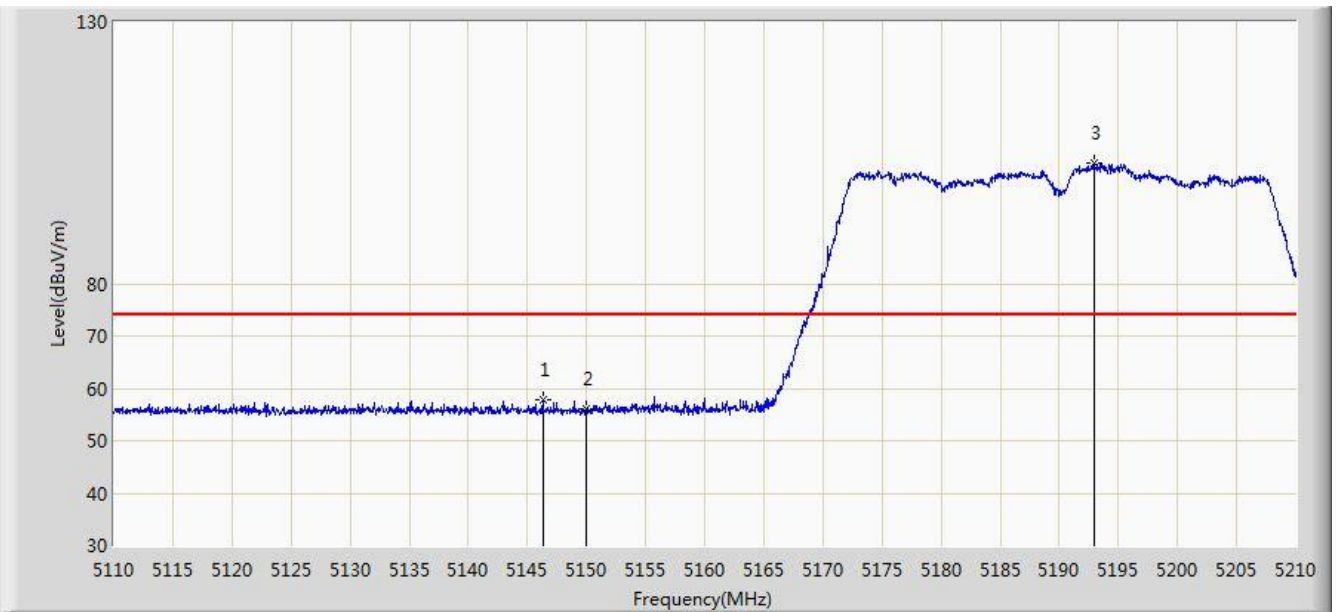

No	Flag	Mark	Frequency (MHz)	Measure Level (dBuV/m)	Reading Level (dBuV)	Over Limit (dB)	Limit (dBuV/m)	Factor (dB)	Type
1			5146.350	57.774	54.696	-16.226	74.000	3.078	PK
2			5150.000	56.002	52.932	-17.998	74.000	3.069	PK
3		*	5192.950	102.995	100.088	N/A	N/A	2.907	PK

Note: Measure Level (dB $\mu$ V/m) = Reading Level (dB $\mu$ V) + Factor (dB)

Factor (dB) = Cable Loss (dB) + Antenna Factor (dB/m) - Pre\_Amplifier Gain (dB)

Site: AC2	Time: 2017/12/02 - 15:44
Limit: FCC_Part15.209_RE(3m)	Engineer: Snake Ni
Probe: BBHA9120D_1-18GHz	Polarity: Horizontal
EUT: VR All-In-One Headset	Power: By Battery
Test Mode: Transmit by 802.11n-HT40 at Channel 5190MHz Ant 0 + 1	

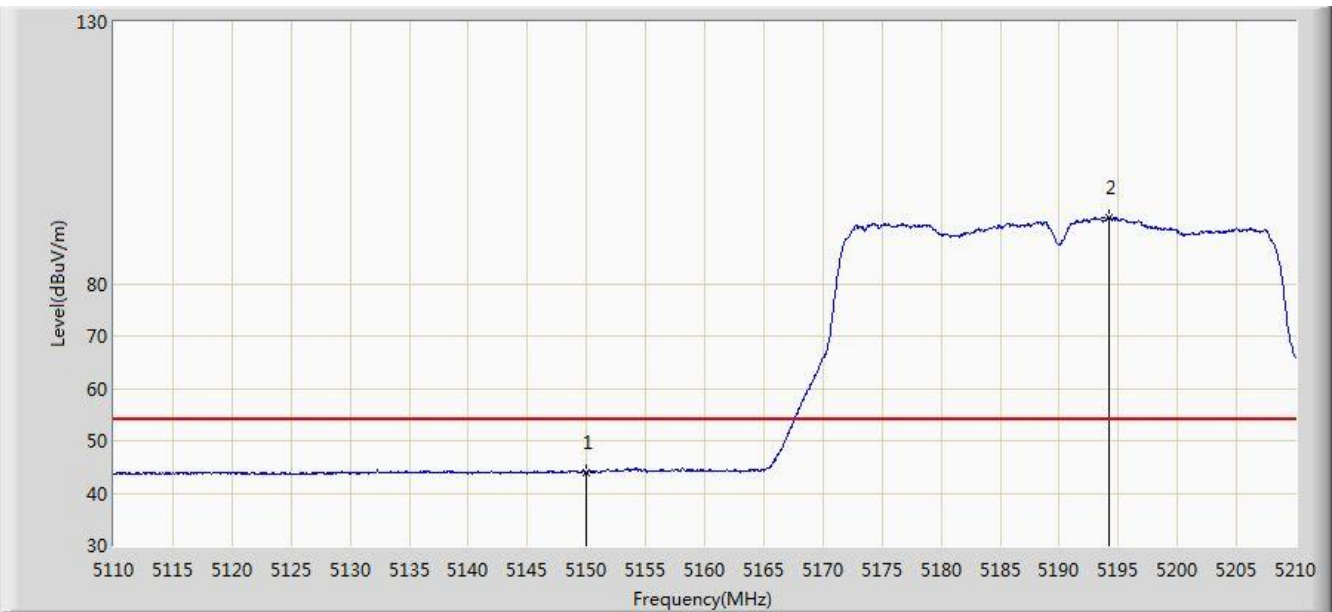

No	Flag	Mark	Frequency (MHz)	Measure Level (dBuV/m)	Reading Level (dBuV)	Over Limit (dB)	Limit (dBuV/m)	Factor (dB)	Type
1			5150.000	43.888	40.818	-10.112	54.000	3.069	AV
2		*	5194.250	92.683	89.795	N/A	N/A	2.888	AV

Note: Measure Level (dBμV/m) = Reading Level (dBμV) + Factor (dB)

Factor (dB) = Cable Loss (dB) + Antenna Factor (dB/m) - Pre\_Amplifier Gain (dB)

Site: AC2	Time: 2017/12/02 - 15:48
Limit: FCC_Part15.209_RE(3m)	Engineer: Snake Ni
Probe: BBHA9120D_1-18GHz	Polarity: Vertical
EUT: VR All-In-One Headset	Power: By Battery
Test Mode: Transmit by 802.11n-HT40 at Channel 5190MHz Ant 0 + 1	

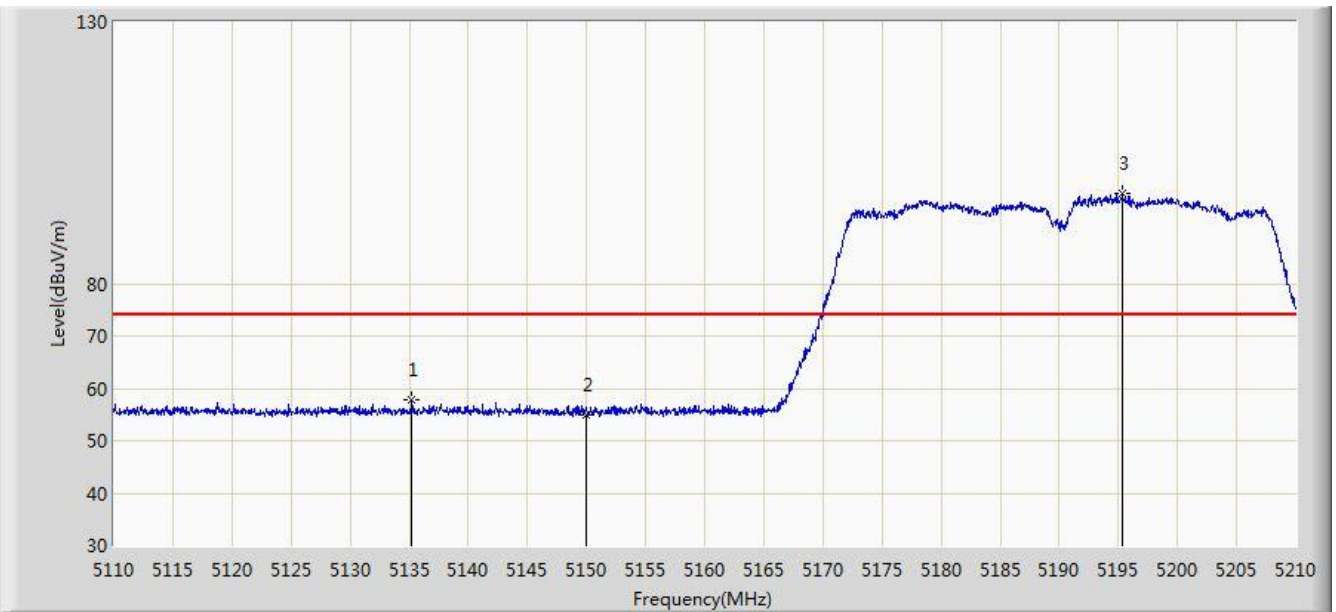

No	Flag	Mark	Frequency (MHz)	Measure Level (dBuV/m)	Reading Level (dBuV)	Over Limit (dB)	Limit (dBuV/m)	Factor (dB)	Type
1			5135.250	57.804	54.684	-16.196	74.000	3.120	PK
2			5150.000	54.943	51.873	-19.057	74.000	3.069	PK
3		*	5195.350	97.244	94.372	N/A	N/A	2.871	PK

Note: Measure Level (dB $\mu$ V/m) = Reading Level (dB $\mu$ V) + Factor (dB)

Factor (dB) = Cable Loss (dB) + Antenna Factor (dB/m) - Pre\_Amplifier Gain (dB)

Site: AC2	Time: 2017/12/02 - 15:49
Limit: FCC_Part15.209_RE(3m)	Engineer: Snake Ni
Probe: BBHA9120D_1-18GHz	Polarity: Vertical
EUT: VR All-In-One Headset	Power: By Battery
Test Mode: Transmit by 802.11n-HT40 at Channel 5190MHz Ant 0 + 1	

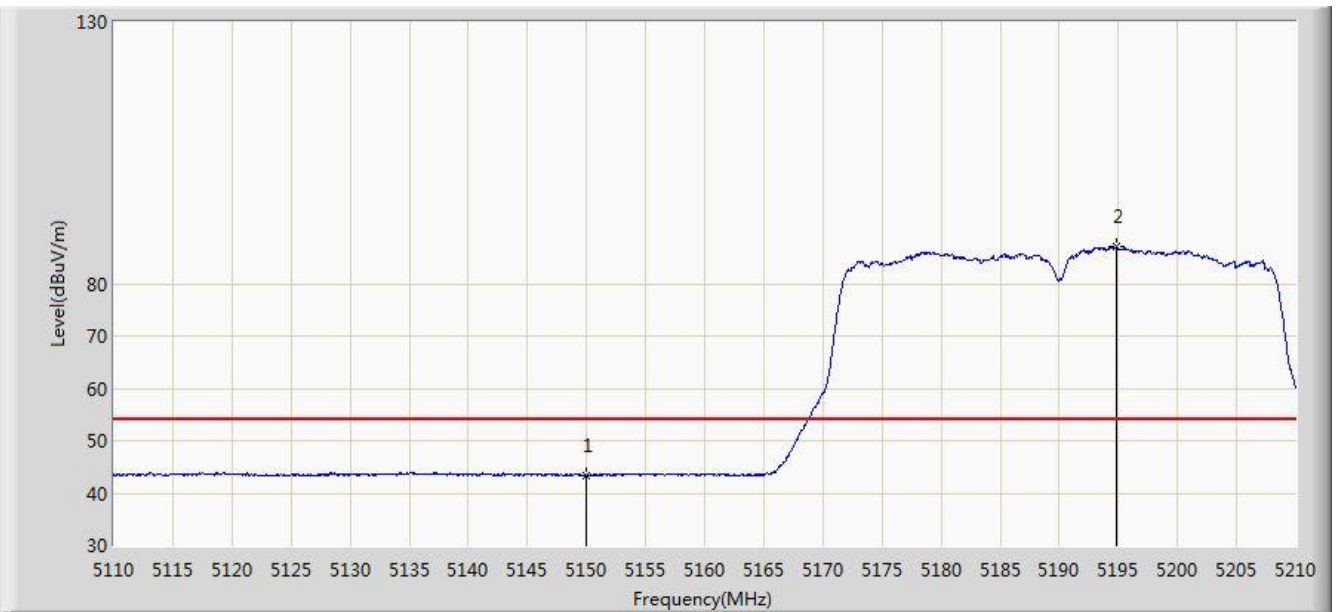

No	Flag	Mark	Frequency (MHz)	Measure Level (dBuV/m)	Reading Level (dBuV)	Over Limit (dB)	Limit (dBuV/m)	Factor (dB)	Type
1			5150.000	43.379	40.309	-10.621	54.000	3.069	AV
2		*	5194.800	87.111	84.231	N/A	N/A	2.880	AV

Note: Measure Level (dB $\mu$ V/m) = Reading Level (dB $\mu$ V) + Factor (dB)

Factor (dB) = Cable Loss (dB) + Antenna Factor (dB/m) - Pre\_Amplifier Gain (dB)

Site: AC2	Time: 2017/12/02 - 15:51
Limit: FCC_Part15.209_RE(3m)	Engineer: Snake Ni
Probe: BBHA9120D_1-18GHz	Polarity: Horizontal
EUT: VR All-In-One Headset	Power: By Battery
Test Mode: Transmit by 802.11n-HT40 at Channel 5310MHz Ant 0 + 1	

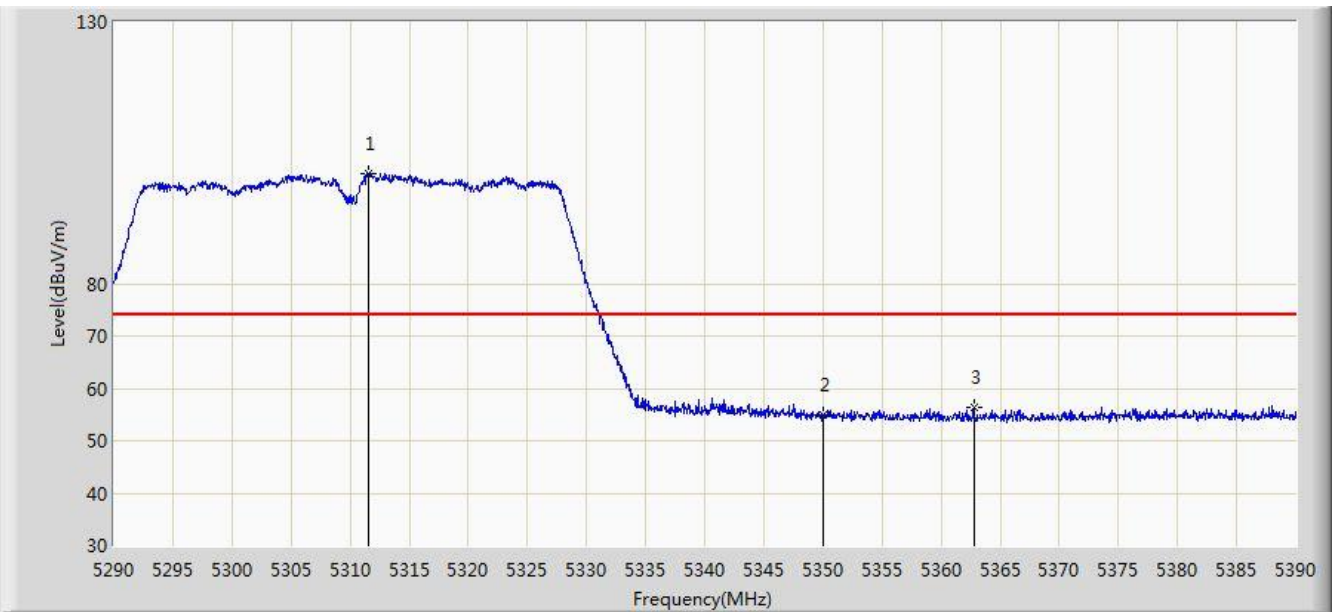

No	Flag	Mark	Frequency (MHz)	Measure Level (dBuV/m)	Reading Level (dBuV)	Over Limit (dB)	Limit (dBuV/m)	Factor (dB)	Type
1		*	5311.550	101.037	98.432	N/A	N/A	2.605	PK
2			5350.000	54.829	52.132	-19.171	74.000	2.697	PK
3			5362.750	56.259	53.532	-17.741	74.000	2.727	PK

Note: Measure Level (dBμV/m) = Reading Level (dBμV) + Factor (dB)

Factor (dB) = Cable Loss (dB) + Antenna Factor (dB/m) - Pre\_Amplifier Gain (dB)

Site: AC2	Time: 2017/12/02 - 15:53
Limit: FCC_Part15.209_RE(3m)	Engineer: Snake Ni
Probe: BBHA9120D_1-18GHz	Polarity: Horizontal
EUT: VR All-In-One Headset	Power: By Battery
Test Mode: Transmit by 802.11n-HT40 at Channel 5310MHz Ant 0 + 1	

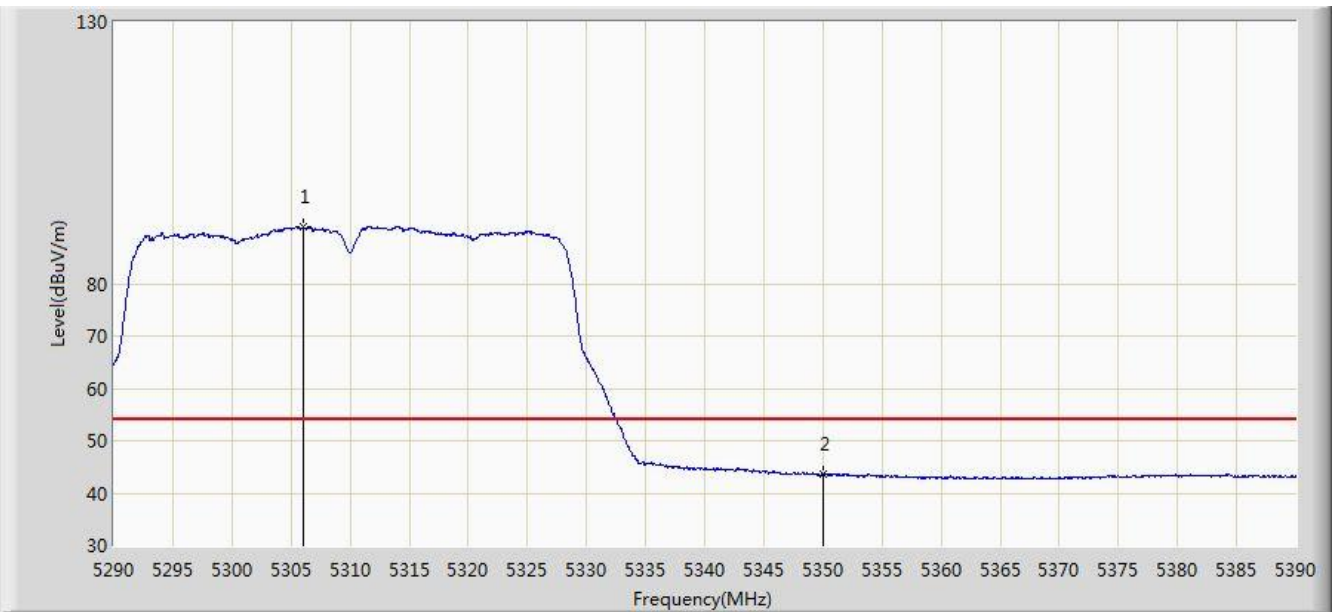

No	Flag	Mark	Frequency (MHz)	Measure Level (dBuV/m)	Reading Level (dBuV)	Over Limit (dB)	Limit (dBuV/m)	Factor (dB)	Type
1		*	5306.100	90.757	88.145	N/A	N/A	2.612	AV
2			5350.000	43.641	40.944	-10.359	54.000	2.697	AV

Note: Measure Level (dB $\mu$ V/m) = Reading Level (dB $\mu$ V) + Factor (dB)

Factor (dB) = Cable Loss (dB) + Antenna Factor (dB/m) - Pre\_Amplifier Gain (dB)

Site: AC2	Time: 2017/12/02 - 15:54
Limit: FCC_Part15.209_RE(3m)	Engineer: Snake Ni
Probe: BBHA9120D_1-18GHz	Polarity: Vertical
EUT: VR All-In-One Headset	Power: By Battery
Test Mode: Transmit by 802.11n-HT40 at Channel 5310MHz Ant 0 + 1	

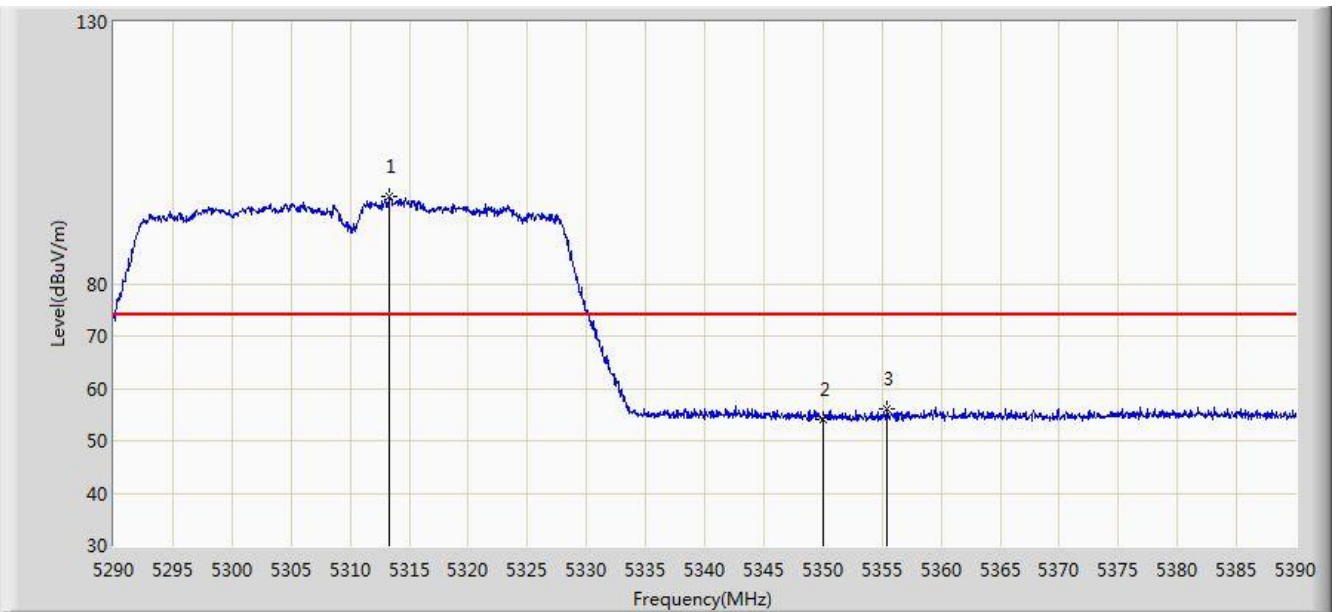

No	Flag	Mark	Frequency (MHz)	Measure Level (dBuV/m)	Reading Level (dBuV)	Over Limit (dB)	Limit (dBuV/m)	Factor (dB)	Type
1		*	5313.250	96.616	94.006	N/A	N/A	2.610	PK
2			5350.000	54.081	51.384	-19.919	74.000	2.697	PK
3			5355.450	56.003	53.291	-17.997	74.000	2.712	PK

Note: Measure Level (dB $\mu$ V/m) = Reading Level (dB $\mu$ V) + Factor (dB)

Factor (dB) = Cable Loss (dB) + Antenna Factor (dB/m) - Pre\_Amplifier Gain (dB)

Site: AC2	Time: 2017/12/02 - 15:56
Limit: FCC_Part15.209_RE(3m)	Engineer: Snake Ni
Probe: BBHA9120D_1-18GHz	Polarity: Vertical
EUT: VR All-In-One Headset	Power: By Battery
Test Mode: Transmit by 802.11n-HT40 at Channel 5310MHz Ant 0 + 1	

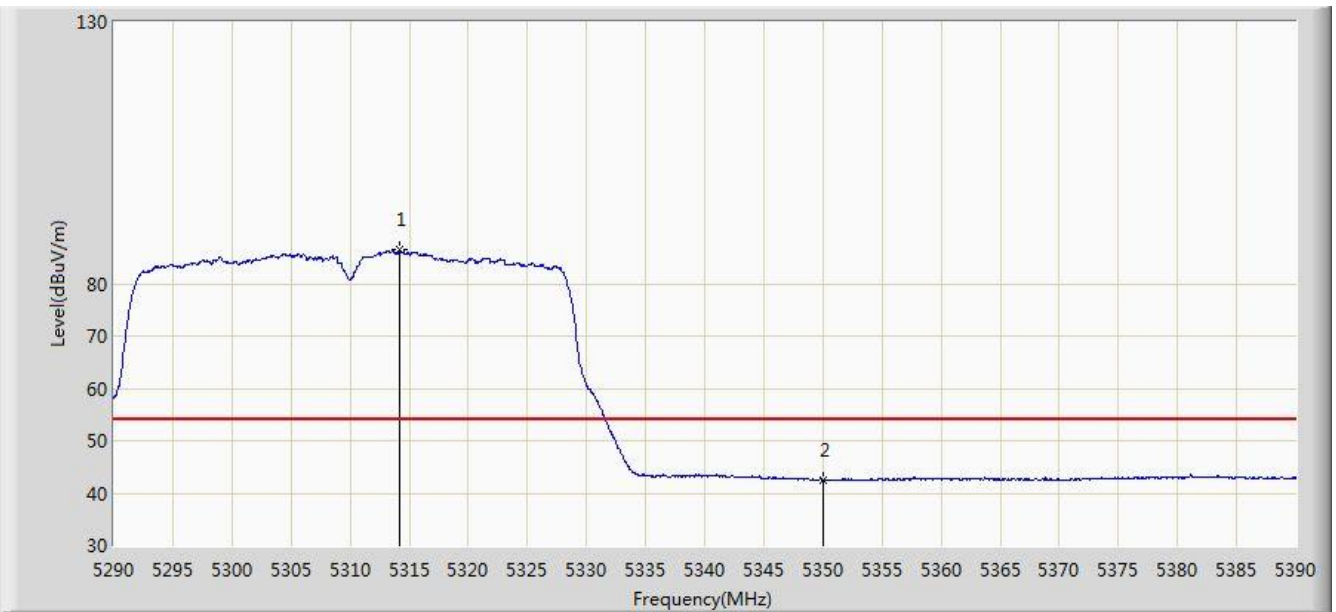

No	Flag	Mark	Frequency (MHz)	Measure Level (dBuV/m)	Reading Level (dBuV)	Over Limit (dB)	Limit (dBuV/m)	Factor (dB)	Type
1		*	5314.200	86.378	83.760	N/A	N/A	2.618	AV
2			5350.000	42.425	39.728	-11.575	54.000	2.697	AV

Note: Measure Level (dBμV/m) = Reading Level (dBμV) + Factor (dB)

Factor (dB) = Cable Loss (dB) + Antenna Factor (dB/m) - Pre\_Amplifier Gain (dB)



Site: AC2	Time: 2017/12/02 - 15:58
Limit: FCC_Part15.209_RE(3m)	Engineer: Snake Ni
Probe: BBHA9120D_1-18GHz	Polarity: Horizontal
EUT: VR All-In-One Headset	Power: By Battery
Test Mode: Transmit by 802.11n-HT40 at Channel 5510MHz Ant 0 + 1	

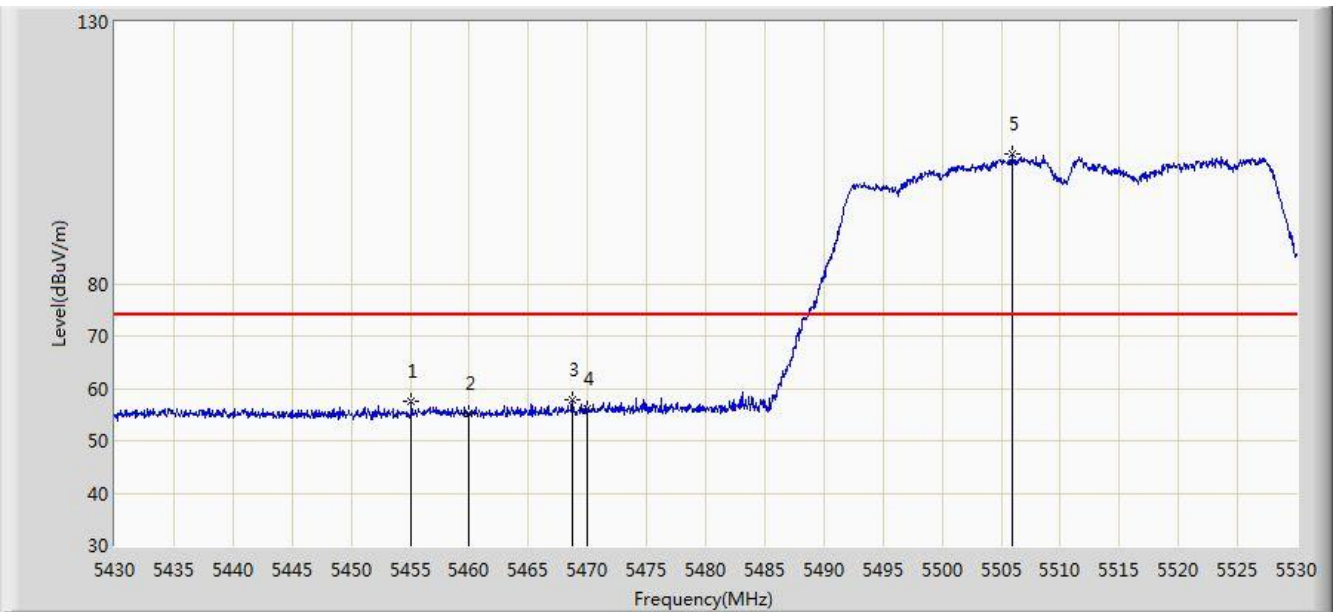

No	Flag	Mark	Frequency (MHz)	Measure Level (dBuV/m)	Reading Level (dBuV)	Over Limit (dB)	Limit (dBuV/m)	Factor (dB)	Type
1			5455.100	57.394	54.365	-16.606	74.000	3.029	PK
2			5460.000	55.152	51.959	-18.848	74.000	3.194	PK
3			5468.750	57.856	54.369	-16.144	74.000	3.487	PK
4			5470.000	56.018	52.489	-17.982	74.000	3.529	PK
5		*	5505.900	104.828	101.740	N/A	N/A	3.088	PK

Note: Measure Level (dB $\mu$ V/m) = Reading Level (dB $\mu$ V) + Factor (dB)

Factor (dB) = Cable Loss (dB) + Antenna Factor (dB/m) - Pre\_Amplifier Gain (dB)

Site: AC2	Time: 2017/12/02 - 15:59
Limit: FCC_Part15.209_RE(3m)	Engineer: Snake Ni
Probe: BBHA9120D_1-18GHz	Polarity: Horizontal
EUT: VR All-In-One Headset	Power: By Battery
Test Mode: Transmit by 802.11n-HT40 at Channel 5510MHz Ant 0 + 1	

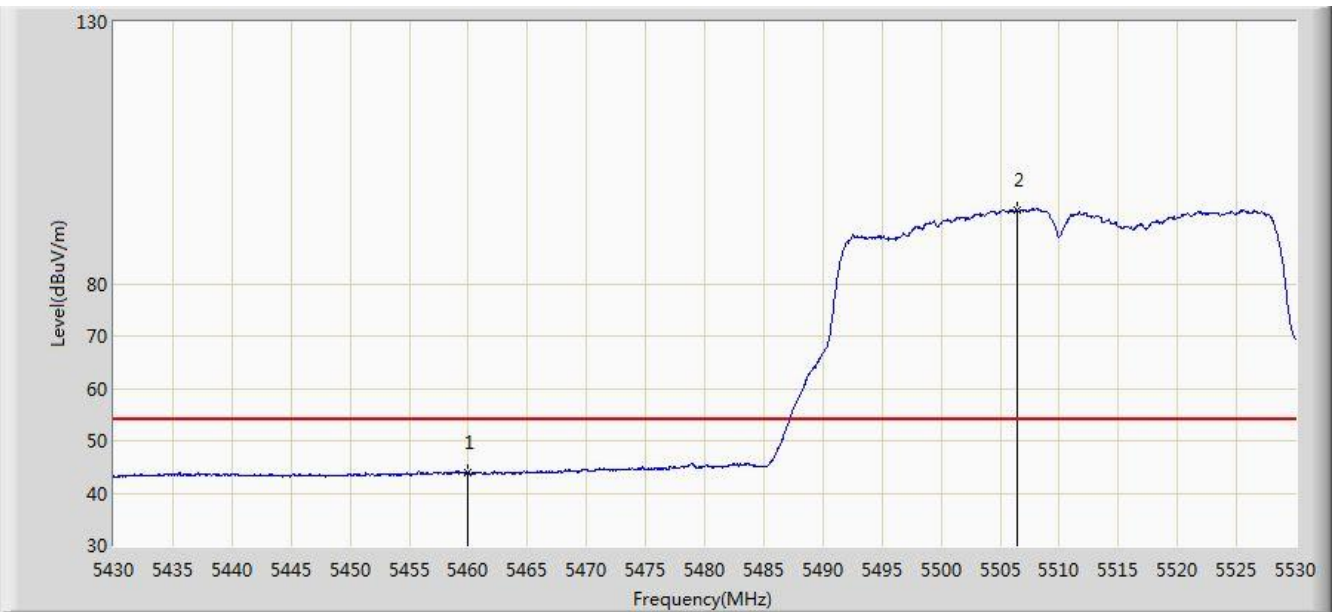

No	Flag	Mark	Frequency (MHz)	Measure Level (dBuV/m)	Reading Level (dBuV)	Over Limit (dB)	Limit (dBuV/m)	Factor (dB)	Type
1			5460.000	44.044	40.851	-9.956	54.000	3.194	AV
2		*	5506.450	94.165	91.064	N/A	N/A	3.101	AV

Note: Measure Level (dBμV/m) = Reading Level (dBμV) + Factor (dB)

Factor (dB) = Cable Loss (dB) + Antenna Factor (dB/m) - Pre\_Amplifier Gain (dB)

Site: AC2	Time: 2017/12/02 - 16:01
Limit: FCC_Part15.209_RE(3m)	Engineer: Snake Ni
Probe: BBHA9120D_1-18GHz	Polarity: Vertical
EUT: VR All-In-One Headset	Power: By Battery
Test Mode: Transmit by 802.11n-HT40 at Channel 5510MHz Ant 0 + 1	

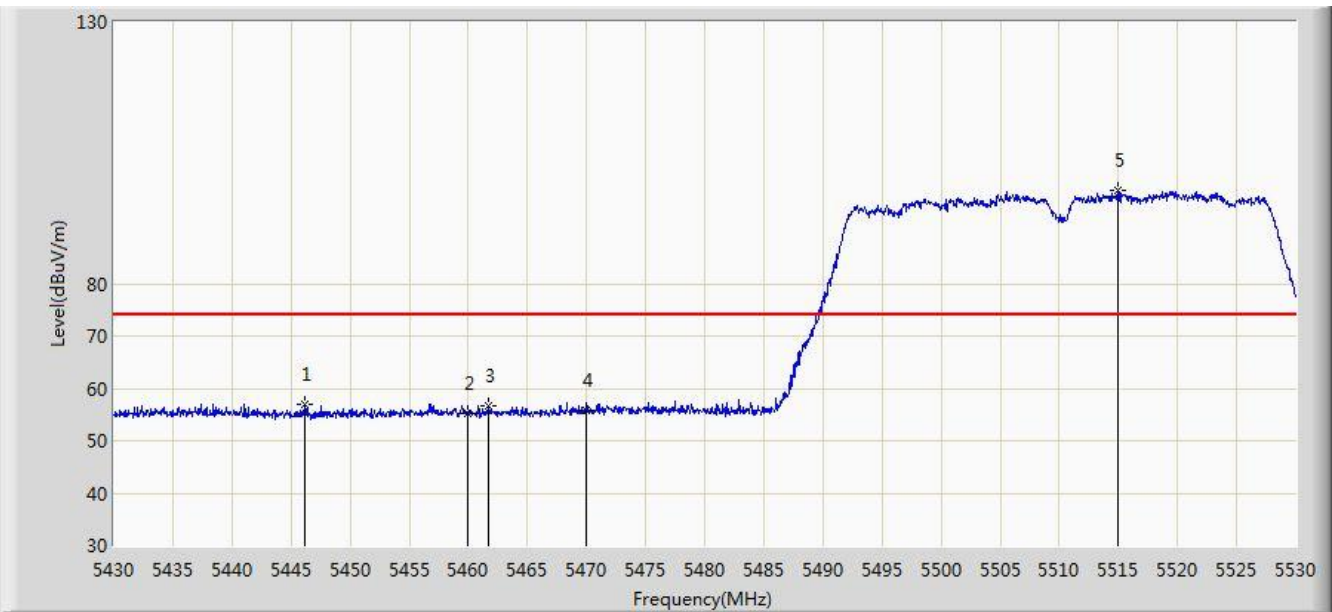

No	Flag	Mark	Frequency (MHz)	Measure Level (dBuV/m)	Reading Level (dBuV)	Over Limit (dB)	Limit (dBuV/m)	Factor (dB)	Type
1			5446.200	56.893	53.799	-17.107	74.000	3.093	PK
2			5460.000	55.185	51.992	-18.815	74.000	3.194	PK
3			5461.700	56.706	53.456	-17.294	74.000	3.251	PK
4			5470.000	55.775	52.246	-18.225	74.000	3.529	PK
5		*	5514.900	97.791	94.484	N/A	N/A	3.307	PK

Note: Measure Level (dBμV/m) = Reading Level (dBμV) + Factor (dB)

Factor (dB) = Cable Loss (dB) + Antenna Factor (dB/m) - Pre\_Amplifier Gain (dB)

Site: AC2	Time: 2017/12/02 - 16:03
Limit: FCC_Part15.209_RE(3m)	Engineer: Snake Ni
Probe: BBHA9120D_1-18GHz	Polarity: Vertical
EUT: VR All-In-One Headset	Power: By Battery
Test Mode: Transmit by 802.11n-HT40 at Channel 5510MHz Ant 0 + 1	

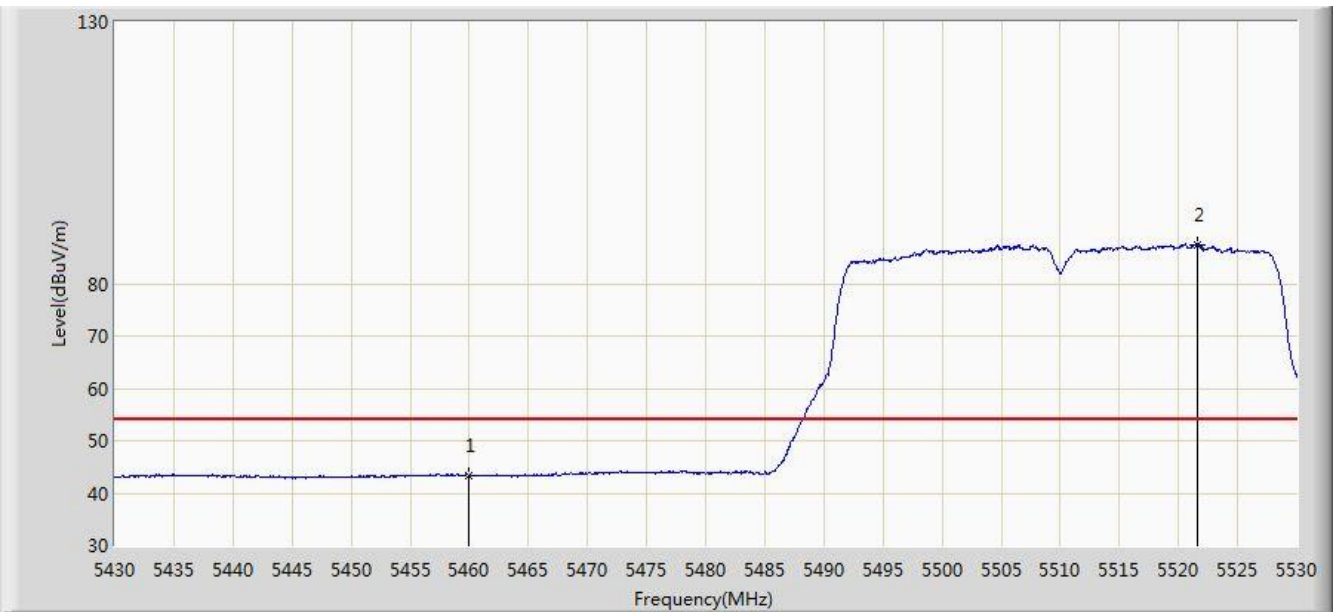

No	Flag	Mark	Frequency (MHz)	Measure Level (dBuV/m)	Reading Level (dBuV)	Over Limit (dB)	Limit (dBuV/m)	Factor (dB)	Type
1			5460.000	43.262	40.069	-10.738	54.000	3.194	AV
2		*	5521.550	87.504	84.036	N/A	N/A	3.469	AV

Note: Measure Level (dB $\mu$ V/m) = Reading Level (dB $\mu$ V) + Factor (dB)

Factor (dB) = Cable Loss (dB) + Antenna Factor (dB/m) - Pre\_Amplifier Gain (dB)

Site: AC2	Time: 2017/12/02 - 16:04
Limit: FCC_Part15.209_RE(3m)	Engineer: Snake Ni
Probe: BBHA9120D_1-18GHz	Polarity: Horizontal
EUT: VR All-In-One Headset	Power: By Battery
Test Mode: Transmit by 802.11n-HT40 at Channel 5670MHz Ant 0 + 1	

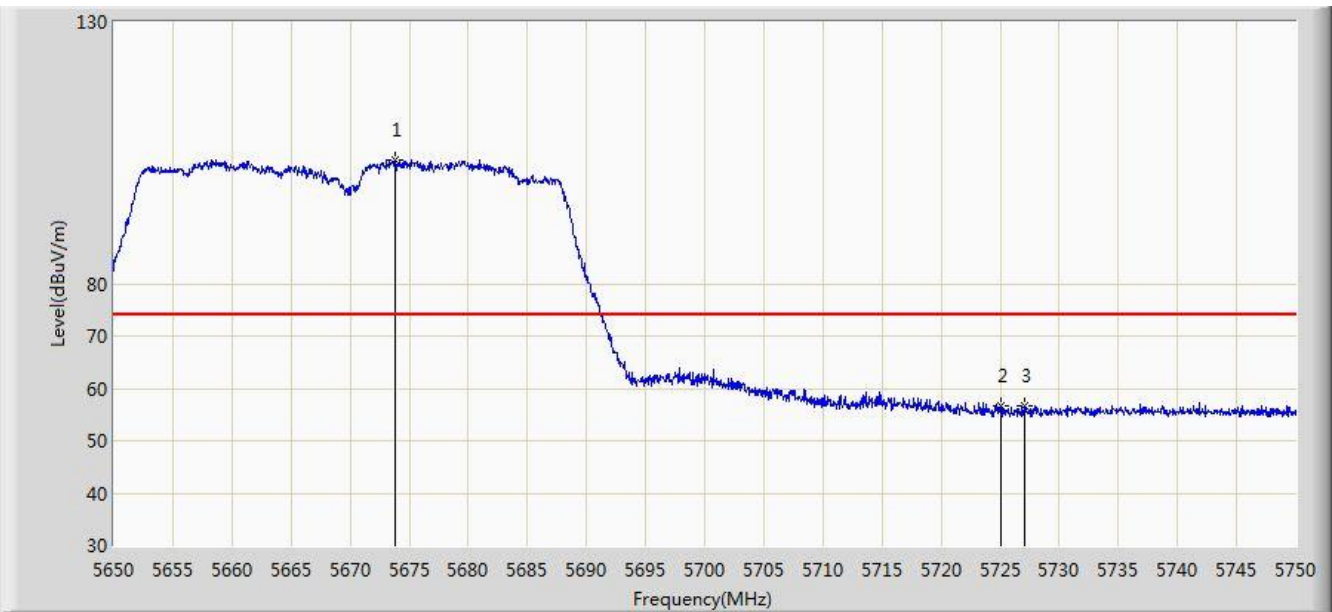

No	Flag	Mark	Frequency (MHz)	Measure Level (dBuV/m)	Reading Level (dBuV)	Over Limit (dB)	Limit (dBuV/m)	Factor (dB)	Type
1		*	5673.850	103.705	99.866	N/A	N/A	3.839	PK
2			5725.000	56.732	52.626	-17.268	74.000	4.105	PK
3			5727.100	56.793	52.635	-17.207	74.000	4.158	PK

Note: Measure Level (dBμV/m) = Reading Level (dBμV) + Factor (dB)

Factor (dB) = Cable Loss (dB) + Antenna Factor (dB/m) - Pre\_Amplifier Gain (dB)

Site: AC2	Time: 2017/12/02 - 16:06
Limit: FCC_Part15.209_RE(3m)	Engineer: Snake Ni
Probe: BBHA9120D_1-18GHz	Polarity: Horizontal
EUT: VR All-In-One Headset	Power: By Battery
Test Mode: Transmit by 802.11n-HT40 at Channel 5670MHz Ant 0 + 1	

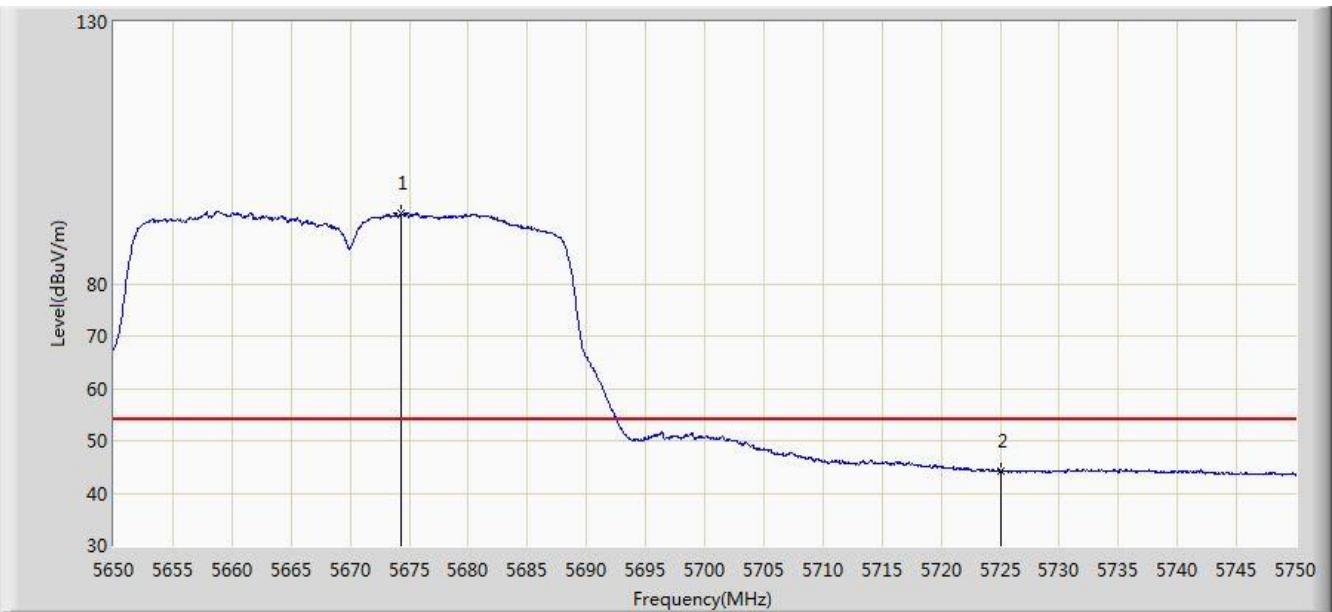

No	Flag	Mark	Frequency (MHz)	Measure Level (dBuV/m)	Reading Level (dBuV)	Over Limit (dB)	Limit (dBuV/m)	Factor (dB)	Type
1		*	5674.350	93.542	89.689	N/A	N/A	3.853	AV
2			5725.000	44.299	40.193	-9.701	54.000	4.105	AV

Note: Measure Level (dBμV/m) = Reading Level (dBμV) + Factor (dB)

Factor (dB) = Cable Loss (dB) + Antenna Factor (dB/m) - Pre\_Amplifier Gain (dB)

Site: AC2	Time: 2017/12/02 - 16:08
Limit: FCC_Part15.209_RE(3m)	Engineer: Snake Ni
Probe: BBHA9120D_1-18GHz	Polarity: Vertical
EUT: VR All-In-One Headset	Power: By Battery
Test Mode: Transmit by 802.11n-HT40 at Channel 5670MHz Ant 0 + 1	

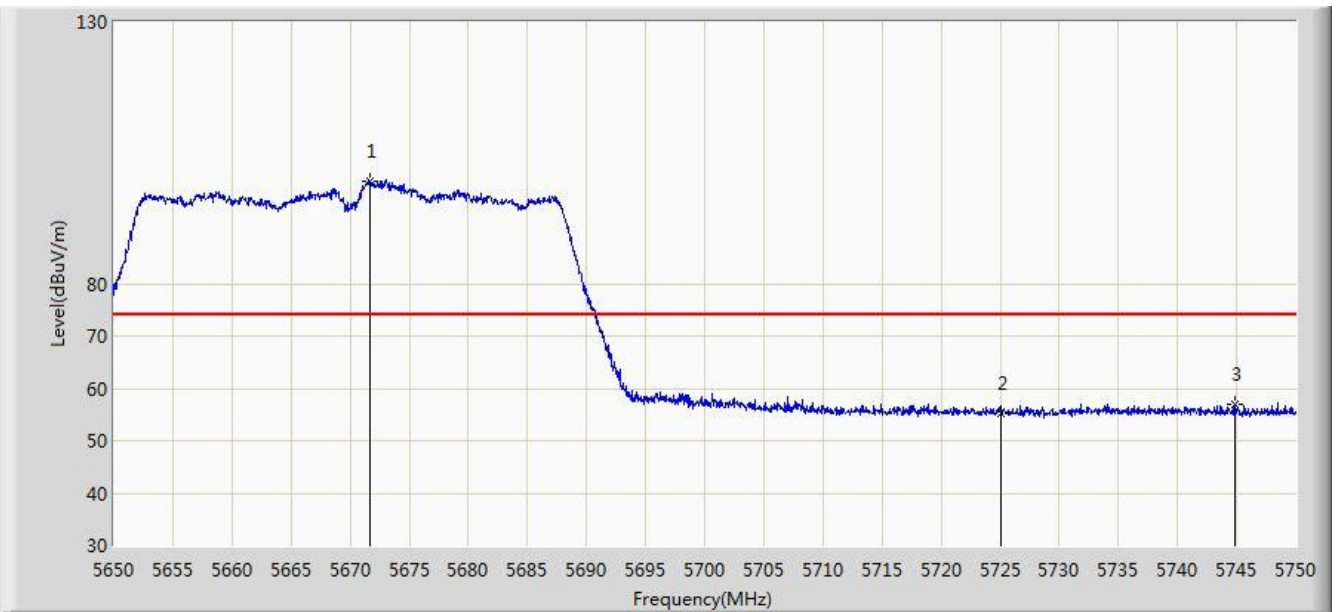

No	Flag	Mark	Frequency (MHz)	Measure Level (dBuV/m)	Reading Level (dBuV)	Over Limit (dB)	Limit (dBuV/m)	Factor (dB)	Type
1		*	5671.700	99.649	95.866	N/A	N/A	3.783	PK
2			5725.000	55.253	51.147	-18.747	74.000	4.105	PK
3			5744.800	56.950	52.681	-17.050	74.000	4.269	PK

Note: Measure Level (dBμV/m) = Reading Level (dBμV) + Factor (dB)

Factor (dB) = Cable Loss (dB) + Antenna Factor (dB/m) - Pre\_Amplifier Gain (dB)

Site: AC2	Time: 2017/12/02 - 16:09
Limit: FCC_Part15.209_RE(3m)	Engineer: Snake Ni
Probe: BBHA9120D_1-18GHz	Polarity: Vertical
EUT: VR All-In-One Headset	Power: By Battery
Test Mode: Transmit by 802.11n-HT40 at Channel 5670MHz Ant 0 + 1	

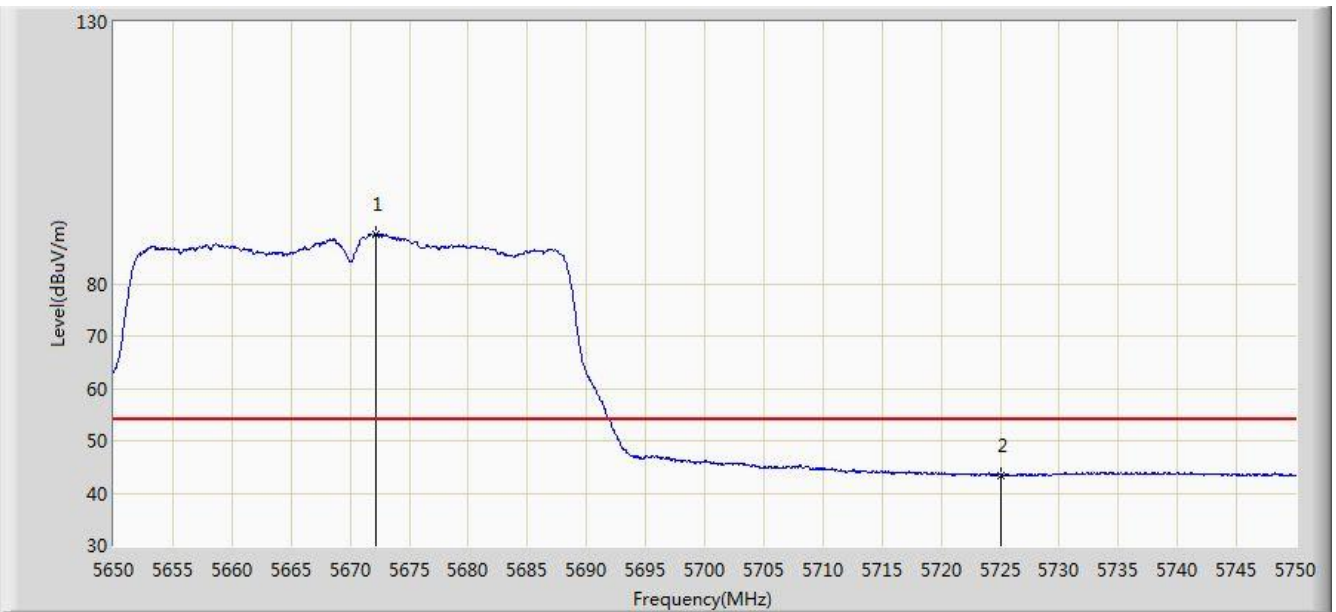

No	Flag	Mark	Frequency (MHz)	Measure Level (dBuV/m)	Reading Level (dBuV)	Over Limit (dB)	Limit (dBuV/m)	Factor (dB)	Type
1		*	5672.200	89.402	85.606	N/A	N/A	3.795	AV
2			5725.000	43.412	39.306	-10.588	54.000	4.105	AV

Note: Measure Level (dB $\mu$ V/m) = Reading Level (dB $\mu$ V) + Factor (dB)

Factor (dB) = Cable Loss (dB) + Antenna Factor (dB/m) - Pre\_Amplifier Gain (dB)



Site: AC2	Time: 2017/12/02 - 16:10
Limit: FCC_Part15.407_RE(3m)	Engineer: Snake Ni
Probe: BBHA9120D_1-18GHz	Polarity: Horizontal
EUT: VR All-In-One Headset	Power: By Battery
Test Mode: Transmit by 802.11n-HT40 at Channel 5755MHz Ant 0 + 1	

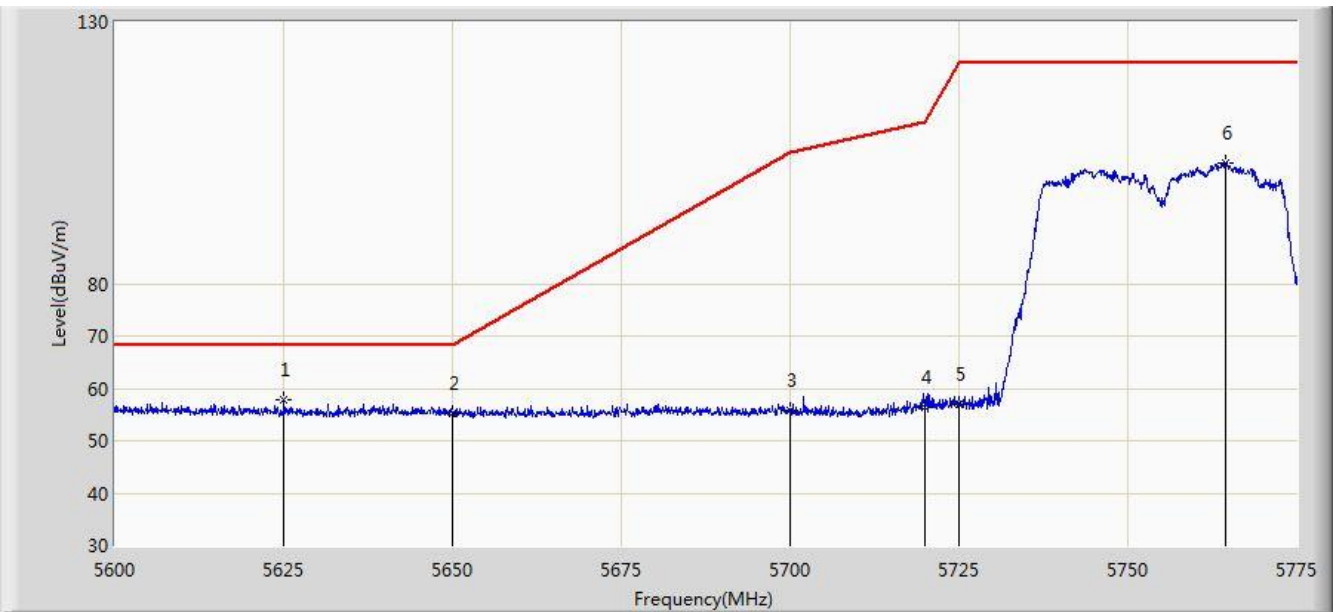

No	Flag	Mark	Frequency (MHz)	Measure Level (dBuV/m)	Reading Level (dBuV)	Over Limit (dB)	Limit (dBuV/m)	Factor (dB)	Type
1		*	5625.025	57.718	54.148	-10.482	68.200	3.570	PK
2			5650.000	55.183	51.380	-13.017	68.200	3.803	PK
3			5700.000	55.871	51.931	-49.329	105.200	3.940	PK
4			5720.000	56.453	52.471	-54.347	110.800	3.982	PK
5			5725.000	56.882	52.776	-65.318	122.200	4.105	PK
6			5764.413	103.156	98.710	N/A	N/A	4.447	PK

Note: Measure Level (dBμV/m) = Reading Level (dBμV) + Factor (dB)

Factor (dB) = Cable Loss (dB) + Antenna Factor (dB/m) - Pre\_Amplifier Gain (dB)

Site: AC2	Time: 2017/12/02 - 16:12
Limit: FCC_Part15.407_RE(3m)	Engineer: Snake Ni
Probe: BBHA9120D_1-18GHz	Polarity: Vertical
EUT: VR All-In-One Headset	Power: By Battery
Test Mode: Transmit by 802.11n-HT40 at Channel 5755MHz Ant 0 + 1	

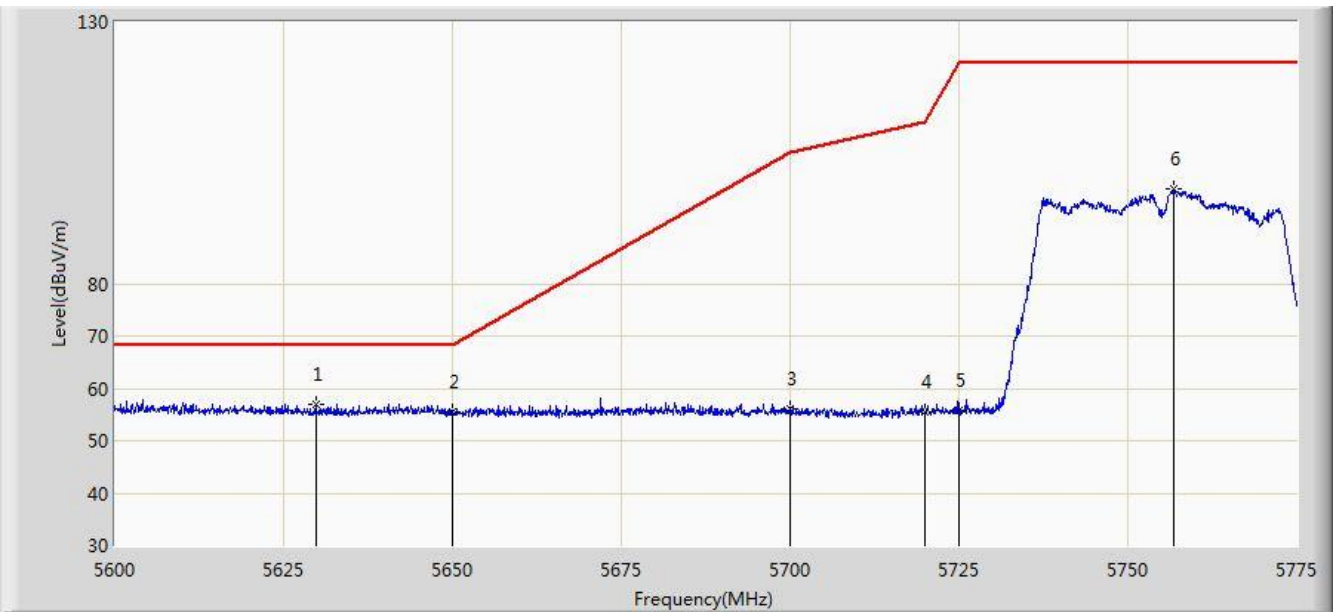

No	Flag	Mark	Frequency (MHz)	Measure Level (dBuV/m)	Reading Level (dBuV)	Over Limit (dB)	Limit (dBuV/m)	Factor (dB)	Type
1		*	5629.750	57.023	53.416	-11.177	68.200	3.608	PK
2			5650.000	55.497	51.694	-12.703	68.200	3.803	PK
3			5700.000	56.226	52.286	-48.974	105.200	3.940	PK
4			5720.000	55.391	51.409	-55.409	110.800	3.982	PK
5			5725.000	55.770	51.664	-66.430	122.200	4.105	PK
6			5756.712	98.172	93.789	N/A	N/A	4.383	PK

Note: Measure Level (dBμV/m) = Reading Level (dBμV) + Factor (dB)

Factor (dB) = Cable Loss (dB) + Antenna Factor (dB/m) - Pre\_Amplifier Gain (dB)

Site: AC2	Time: 2017/12/02 - 16:14
Limit: FCC_Part15.407_RE(3m)	Engineer: Snake Ni
Probe: BBHA9120D_1-18GHz	Polarity: Horizontal
EUT: VR All-In-One Headset	Power: By Battery
Test Mode: Transmit by 802.11n-HT40 at Channel 5795MHz Ant 0 + 1	

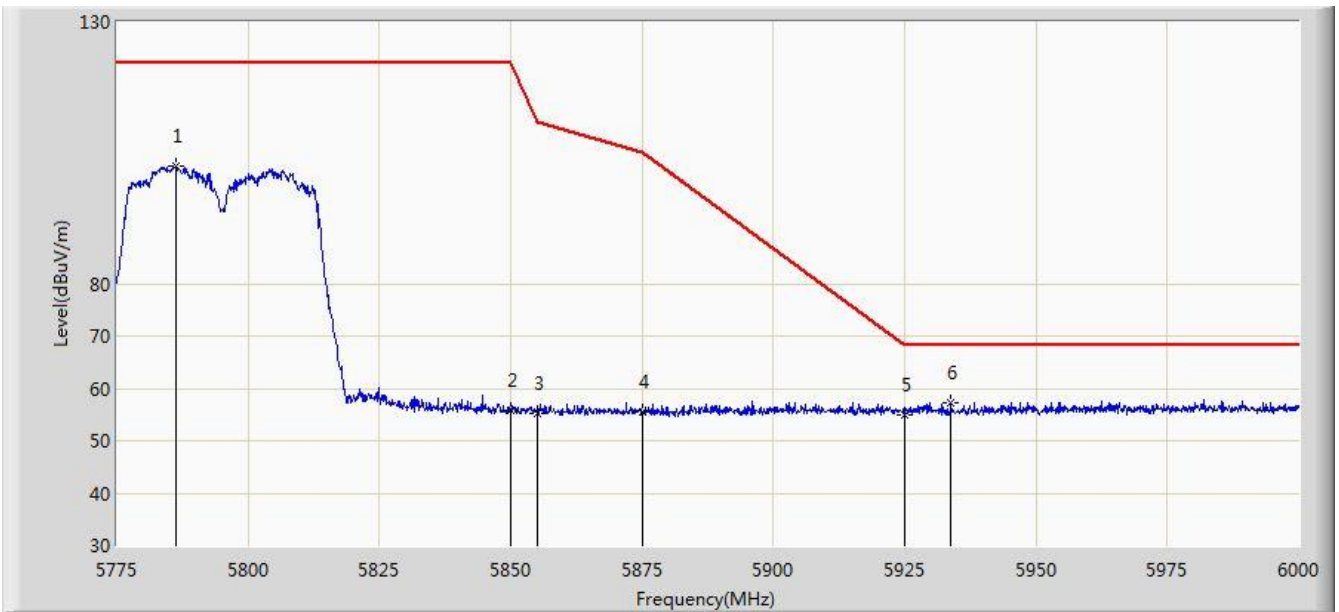

No	Flag	Mark	Frequency (MHz)	Measure Level (dBuV/m)	Reading Level (dBuV)	Over Limit (dB)	Limit (dBuV/m)	Factor (dB)	Type
1			5786.138	102.531	98.045	N/A	N/A	4.486	PK
2			5850.000	55.906	50.911	-66.294	122.200	4.995	PK
3			5855.000	55.246	50.258	-55.554	110.800	4.987	PK
4			5875.000	55.446	50.439	-49.754	105.200	5.008	PK
5			5925.000	55.011	49.859	-13.189	68.200	5.152	PK
6		*	5933.850	57.311	52.124	-10.889	68.200	5.187	PK

Note: Measure Level (dB $\mu$ V/m) = Reading Level (dB $\mu$ V) + Factor (dB)

Factor (dB) = Cable Loss (dB) + Antenna Factor (dB/m) - Pre\_Amplifier Gain (dB)

Site: AC2	Time: 2017/12/02 - 16:16
Limit: FCC_Part15.407_RE(3m)	Engineer: Snake Ni
Probe: BBHA9120D_1-18GHz	Polarity: Vertical
EUT: VR All-In-One Headset	Power: By Battery
Test Mode: Transmit by 802.11n-HT40 at Channel 5795MHz Ant 0 + 1	

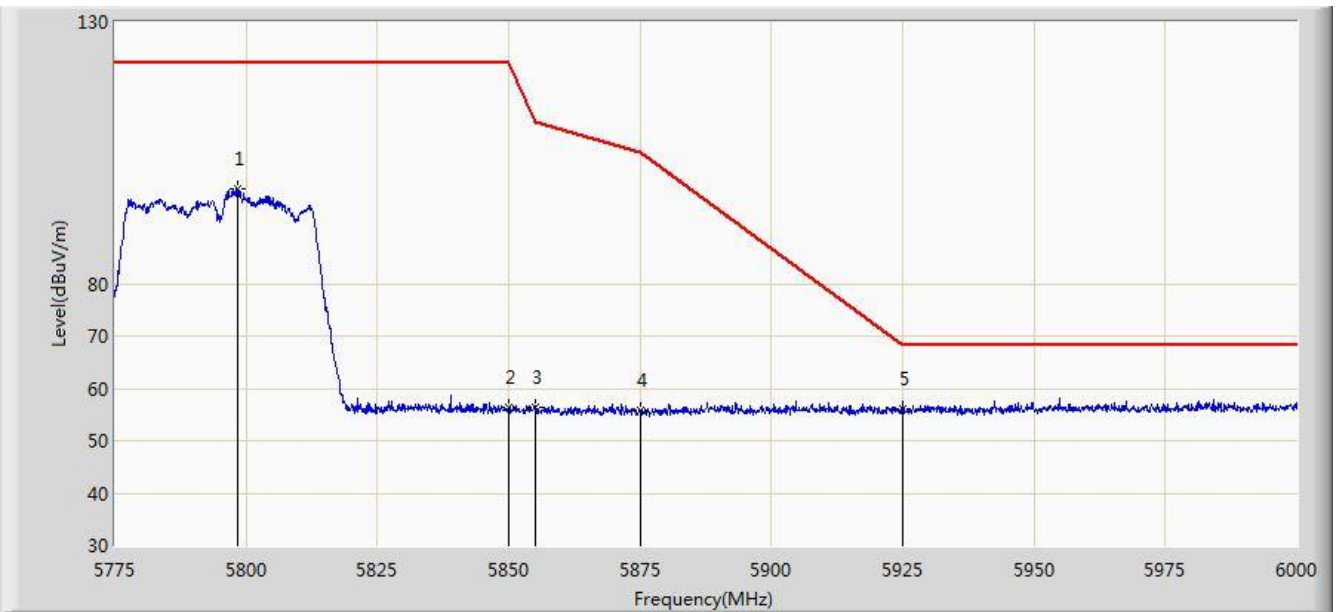

No	Flag	Mark	Frequency (MHz)	Measure Level (dBuV/m)	Reading Level (dBuV)	Over Limit (dB)	Limit (dBuV/m)	Factor (dB)	Type
1			5798.288	98.211	93.579	N/A	N/A	4.632	PK
2			5850.000	56.291	51.296	-65.909	122.200	4.995	PK
3			5855.000	56.449	51.461	-54.351	110.800	4.987	PK
4			5875.000	55.761	50.754	-49.439	105.200	5.008	PK
5		*	5925.000	56.213	51.061	-11.987	68.200	5.152	PK

Note: Measure Level (dBμV/m) = Reading Level (dBμV) + Factor (dB)

Factor (dB) = Cable Loss (dB) + Antenna Factor (dB/m) - Pre\_Amplifier Gain (dB)

Site: AC2	Time: 2017/12/06 - 16:02
Limit: FCC_Part15.209_RE(3m)	Engineer: Snake Ni
Probe: BBHA9120D_1-18GHz	Polarity: Horizontal
EUT: VR All-In-One Headset	Power: By Battery
Test Mode: Transmit by 802.11ac-VHT20 at Channel 5180MHz Ant 0 + 1	

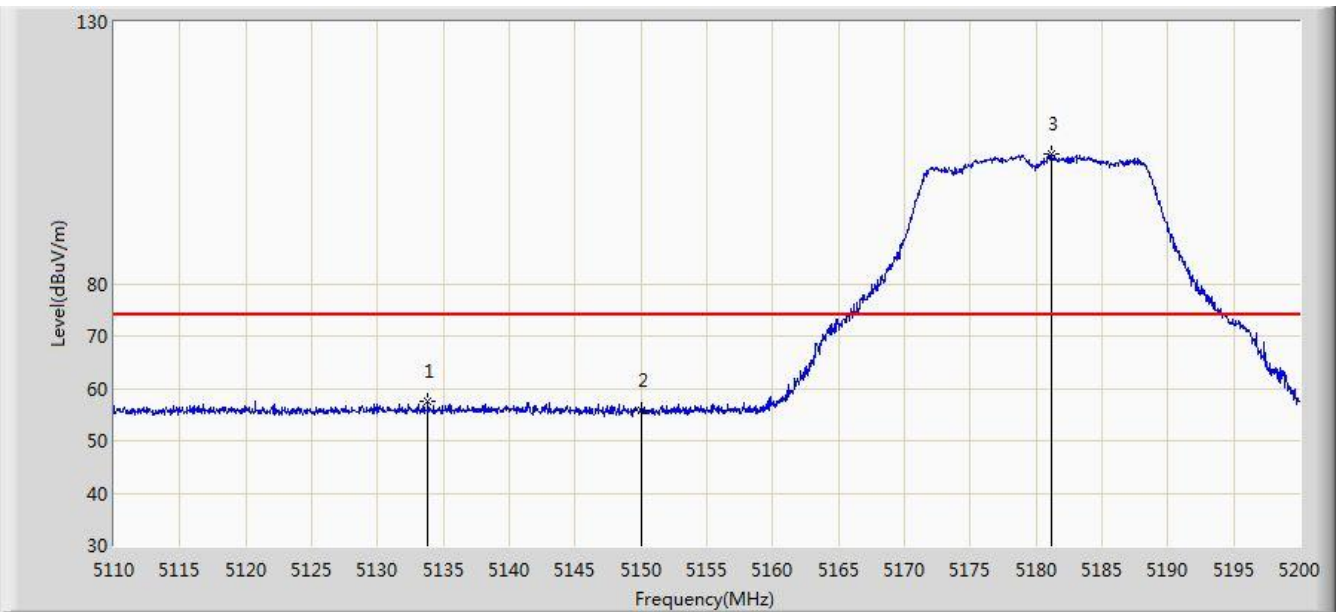

No	Flag	Mark	Frequency (MHz)	Measure Level (dBuV/m)	Reading Level (dBuV)	Over Limit (dB)	Limit (dBuV/m)	Factor (dB)	Type
1			5133.850	57.535	54.404	-16.465	74.000	3.131	PK
2			5150.000	55.834	52.764	-18.166	74.000	3.069	PK
3		*	5181.145	104.857	101.810	N/A	N/A	3.048	PK

Note: Measure Level (dBμV/m) = Reading Level (dBμV) + Factor (dB)

Factor (dB) = Cable Loss (dB) + Antenna Factor (dB/m) - Pre\_Amplifier Gain (dB)

Site: AC2	Time: 2017/12/06 - 16:07
Limit: FCC_Part15.209_RE(3m)	Engineer: Snake Ni
Probe: BBHA9120D_1-18GHz	Polarity: Horizontal
EUT: VR All-In-One Headset	Power: By Battery
Test Mode: Transmit by 802.11ac-VHT20 at Channel 5180MHz Ant 0 + 1	

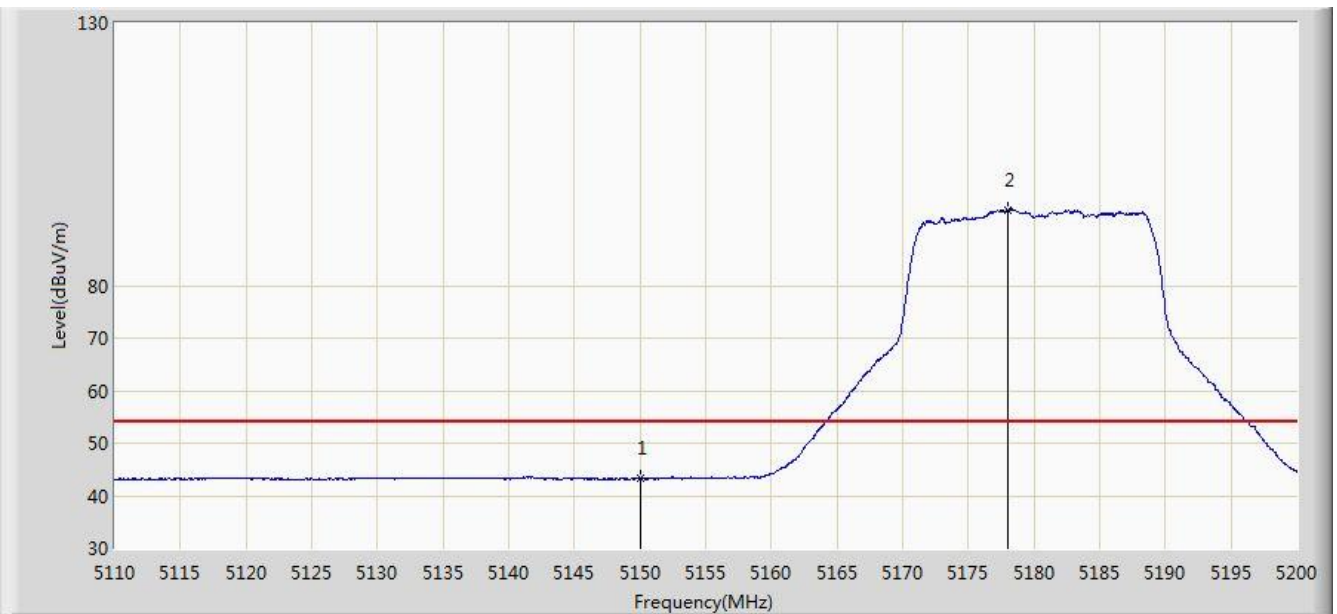

No	Flag	Mark	Frequency (MHz)	Measure Level (dBuV/m)	Reading Level (dBuV)	Over Limit (dB)	Limit (dBuV/m)	Factor (dB)	Type
1			5150.000	43.208	40.138	-10.792	54.000	3.069	AV
2		*	5177.995	94.447	91.412	N/A	N/A	3.035	AV

Note: Measure Level (dB $\mu$ V/m) = Reading Level (dB $\mu$ V) + Factor (dB)

Factor (dB) = Cable Loss (dB) + Antenna Factor (dB/m) - Pre\_Amplifier Gain (dB)

Site: AC2	Time: 2017/12/06 - 16:09
Limit: FCC_Part15.209_RE(3m)	Engineer: Snake Ni
Probe: BBHA9120D_1-18GHz	Polarity: Vertical
EUT: VR All-In-One Headset	Power: By Battery
Test Mode: Transmit by 802.11ac-VHT20 at Channel 5180MHz Ant 0 + 1	

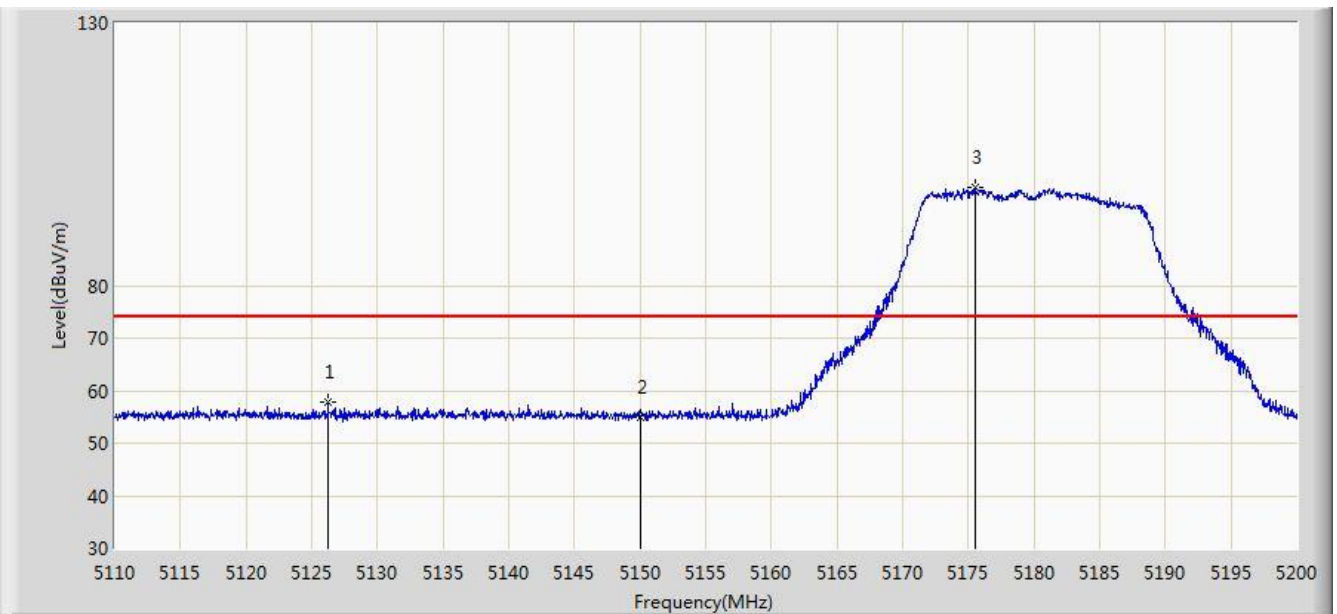

No	Flag	Mark	Frequency (MHz)	Measure Level (dBuV/m)	Reading Level (dBuV)	Over Limit (dB)	Limit (dBuV/m)	Factor (dB)	Type
1			5126.245	57.861	54.696	-16.139	74.000	3.165	PK
2			5150.000	54.905	51.835	-19.095	74.000	3.069	PK
3		*	5175.475	98.586	95.561	N/A	N/A	3.026	PK

Note: Measure Level (dB $\mu$ V/m) = Reading Level (dB $\mu$ V) + Factor (dB)

Factor (dB) = Cable Loss (dB) + Antenna Factor (dB/m) - Pre\_Amplifier Gain (dB)

Site: AC2	Time: 2017/12/06 - 16:10
Limit: FCC_Part15.209_RE(3m)	Engineer: Snake Ni
Probe: BBHA9120D_1-18GHz	Polarity: Vertical
EUT: VR All-In-One Headset	Power: By Battery
Test Mode: Transmit by 802.11ac-VHT20 at Channel 5180MHz Ant 0 + 1	

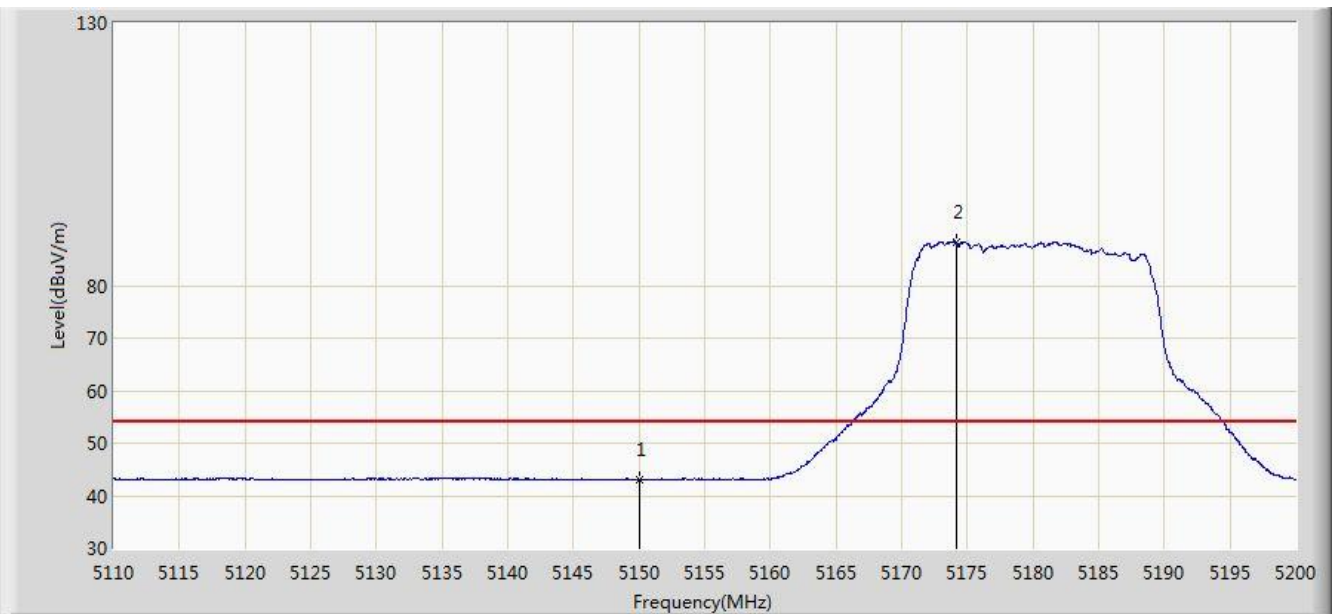

No	Flag	Mark	Frequency (MHz)	Measure Level (dBuV/m)	Reading Level (dBuV)	Over Limit (dB)	Limit (dBuV/m)	Factor (dB)	Type
1			5150.000	43.024	39.954	-10.976	54.000	3.069	AV
2		*	5174.170	88.244	85.224	N/A	N/A	3.020	AV

Note: Measure Level (dBμV/m) = Reading Level (dBμV) + Factor (dB)

Factor (dB) = Cable Loss (dB) + Antenna Factor (dB/m) - Pre\_Amplifier Gain (dB)



Site: AC2	Time: 2017/12/06 - 16:12
Limit: FCC_Part15.209_RE(3m)	Engineer: Snake Ni
Probe: BBHA9120D_1-18GHz	Polarity: Horizontal
EUT: VR All-In-One Headset	Power: By Battery
Test Mode: Transmit by 802.11ac-VHT20 at Channel 5320MHz Ant 0 + 1	

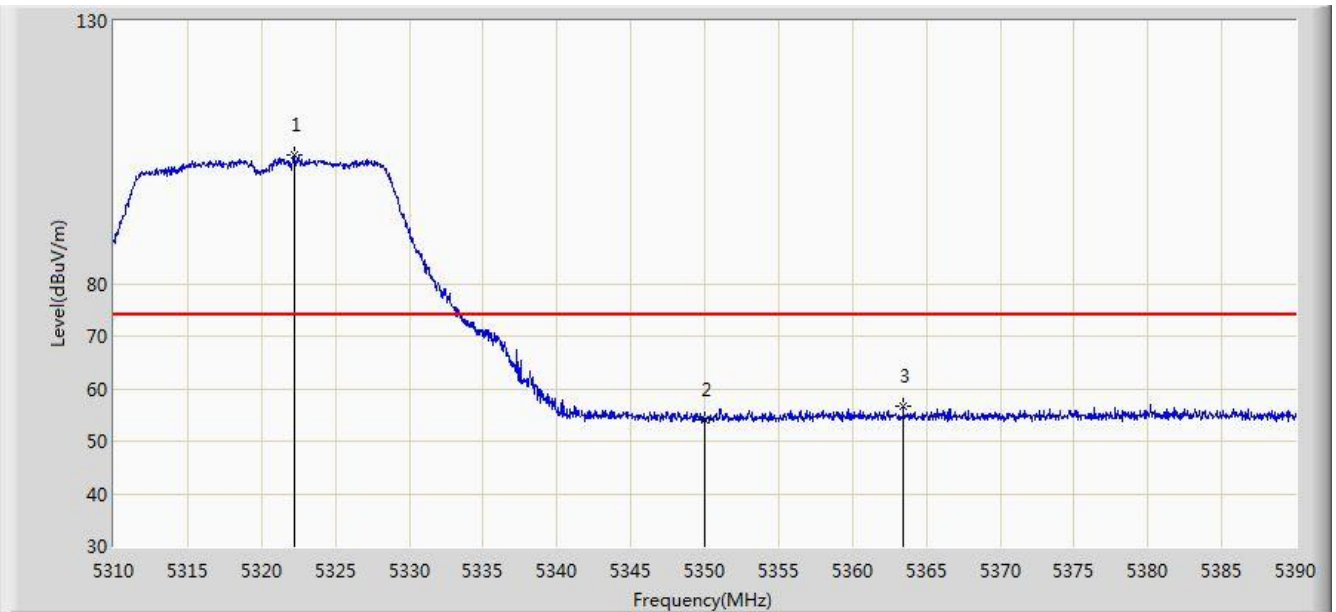

No	Flag	Mark	Frequency (MHz)	Measure Level (dBuV/m)	Reading Level (dBuV)	Over Limit (dB)	Limit (dBuV/m)	Factor (dB)	Type
1		*	5322.280	104.481	101.809	N/A	N/A	2.673	PK
2			5350.000	54.192	51.495	-19.808	74.000	2.697	PK
3			5363.440	56.621	53.892	-17.379	74.000	2.728	PK

Note: Measure Level (dBμV/m) = Reading Level (dBμV) + Factor (dB)

Factor (dB) = Cable Loss (dB) + Antenna Factor (dB/m) - Pre\_Amplifier Gain (dB)

Site: AC2	Time: 2017/12/06 - 16:13
Limit: FCC_Part15.209_RE(3m)	Engineer: Snake Ni
Probe: BBHA9120D_1-18GHz	Polarity: Horizontal
EUT: VR All-In-One Headset	Power: By Battery
Test Mode: Transmit by 802.11ac-VHT20 at Channel 5320MHz Ant 0 + 1	

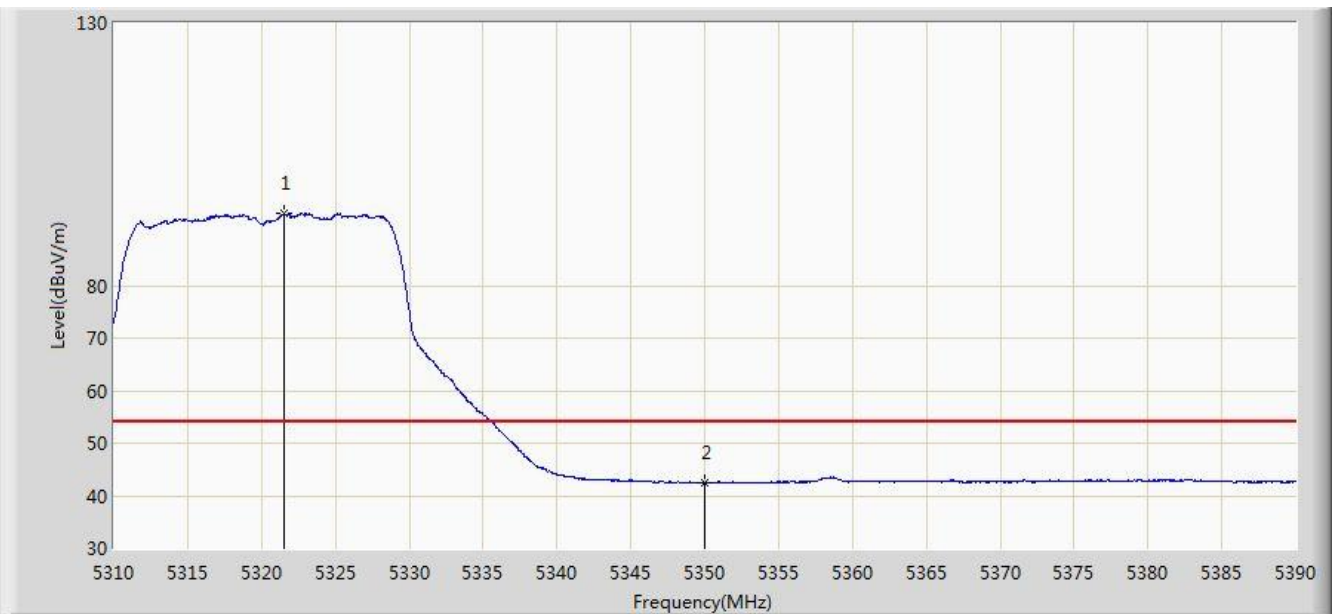

No	Flag	Mark	Frequency (MHz)	Measure Level (dBuV/m)	Reading Level (dBuV)	Over Limit (dB)	Limit (dBuV/m)	Factor (dB)	Type
1		*	5321.520	93.650	90.981	N/A	N/A	2.668	AV
2			5350.000	42.441	39.744	-11.559	54.000	2.697	AV

Note: Measure Level (dBμV/m) = Reading Level (dBμV) + Factor (dB)

Factor (dB) = Cable Loss (dB) + Antenna Factor (dB/m) - Pre\_Amplifier Gain (dB)

Site: AC2	Time: 2017/12/06 - 16:14
Limit: FCC_Part15.209_RE(3m)	Engineer: Snake Ni
Probe: BBHA9120D_1-18GHz	Polarity: Vertical
EUT: VR All-In-One Headset	Power: By Battery
Test Mode: Transmit by 802.11ac-VHT20 at Channel 5320MHz Ant 0 + 1	

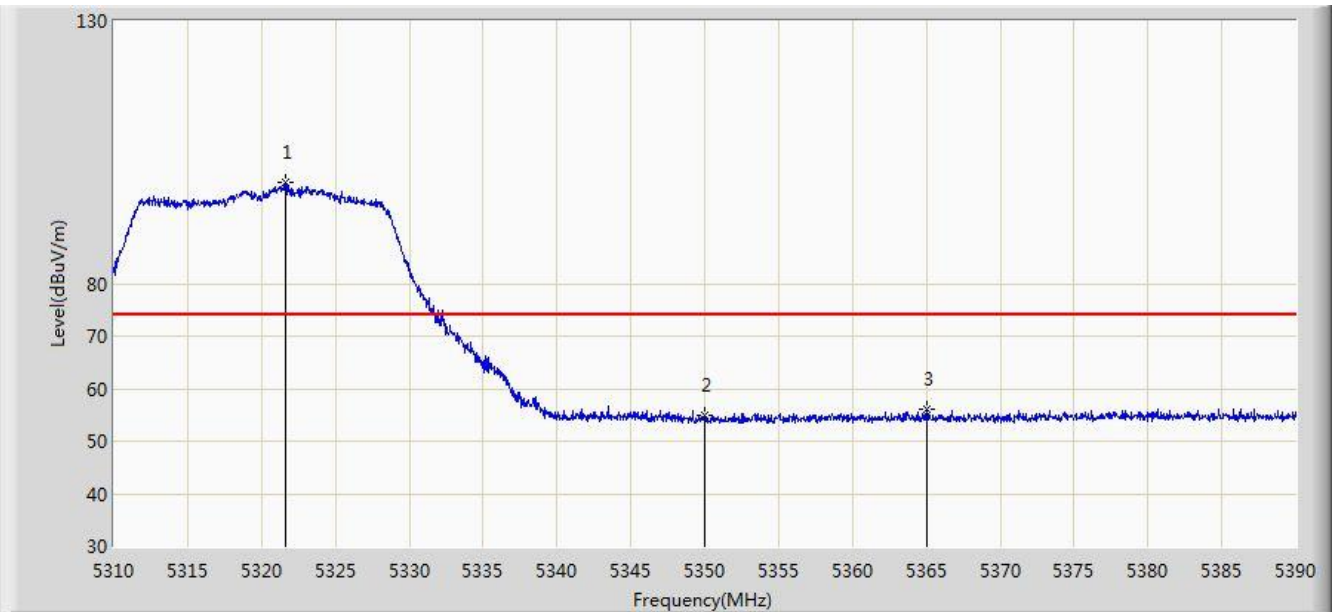

No	Flag	Mark	Frequency (MHz)	Measure Level (dBuV/m)	Reading Level (dBuV)	Over Limit (dB)	Limit (dBuV/m)	Factor (dB)	Type
1		*	5321.600	99.326	96.657	N/A	N/A	2.669	PK
2			5350.000	54.974	52.277	-19.026	74.000	2.697	PK
3			5365.000	56.095	53.363	-17.905	74.000	2.732	PK

Note: Measure Level (dB $\mu$ V/m) = Reading Level (dB $\mu$ V) + Factor (dB)

Factor (dB) = Cable Loss (dB) + Antenna Factor (dB/m) - Pre\_Amplifier Gain (dB)

Site: AC2	Time: 2017/12/06 - 16:16
Limit: FCC_Part15.209_RE(3m)	Engineer: Snake Ni
Probe: BBHA9120D_1-18GHz	Polarity: Vertical
EUT: VR All-In-One Headset	Power: By Battery
Test Mode: Transmit by 802.11ac-VHT20 at Channel 5320MHz Ant 0 + 1	

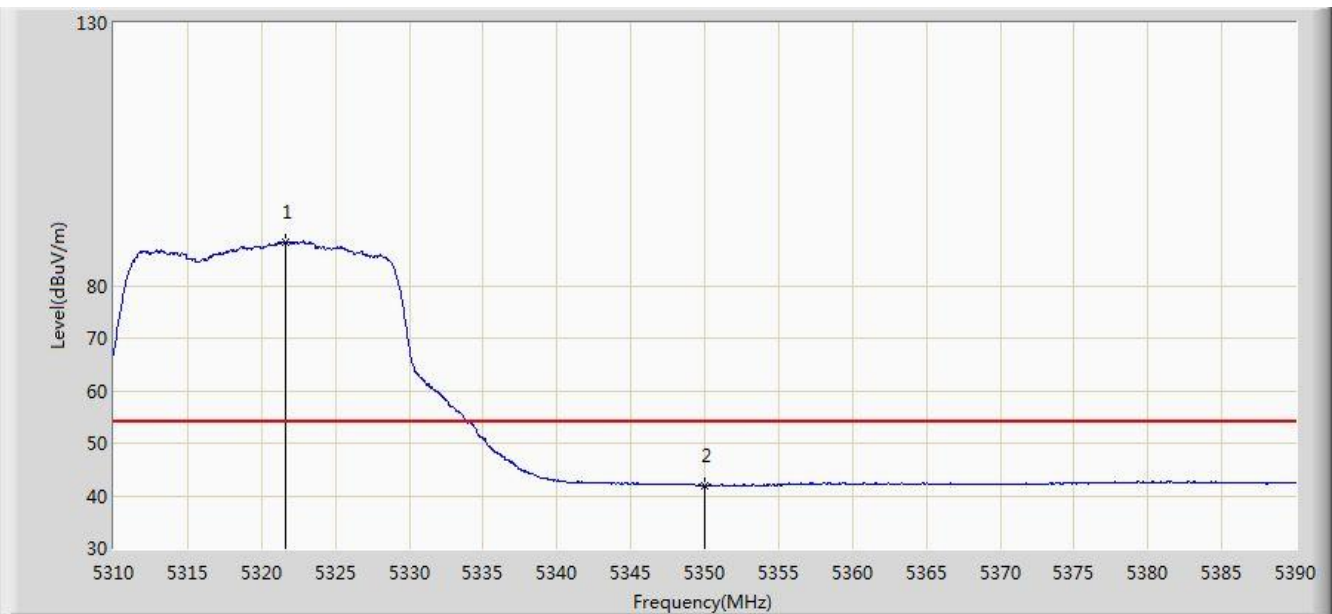

No	Flag	Mark	Frequency (MHz)	Measure Level (dBuV/m)	Reading Level (dBuV)	Over Limit (dB)	Limit (dBuV/m)	Factor (dB)	Type
1		*	5321.640	88.250	85.581	N/A	N/A	2.669	AV
2			5350.000	41.989	39.292	-12.011	54.000	2.697	AV

Note: Measure Level (dBμV/m) = Reading Level (dBμV) + Factor (dB)

Factor (dB) = Cable Loss (dB) + Antenna Factor (dB/m) - Pre\_Amplifier Gain (dB)

Site: AC2	Time: 2017/12/08 - 18:40
Limit: FCC_Part15.209_RE(3m)	Engineer: Snake Ni
Probe: BBHA9120D_1-18GHz	Polarity: Horizontal
EUT: VR All-In-One Headset	Power: By Battery
Test Mode: Transmit by 802.11ac-VHT20 at Channel 5500MHz Ant 0 + 1	

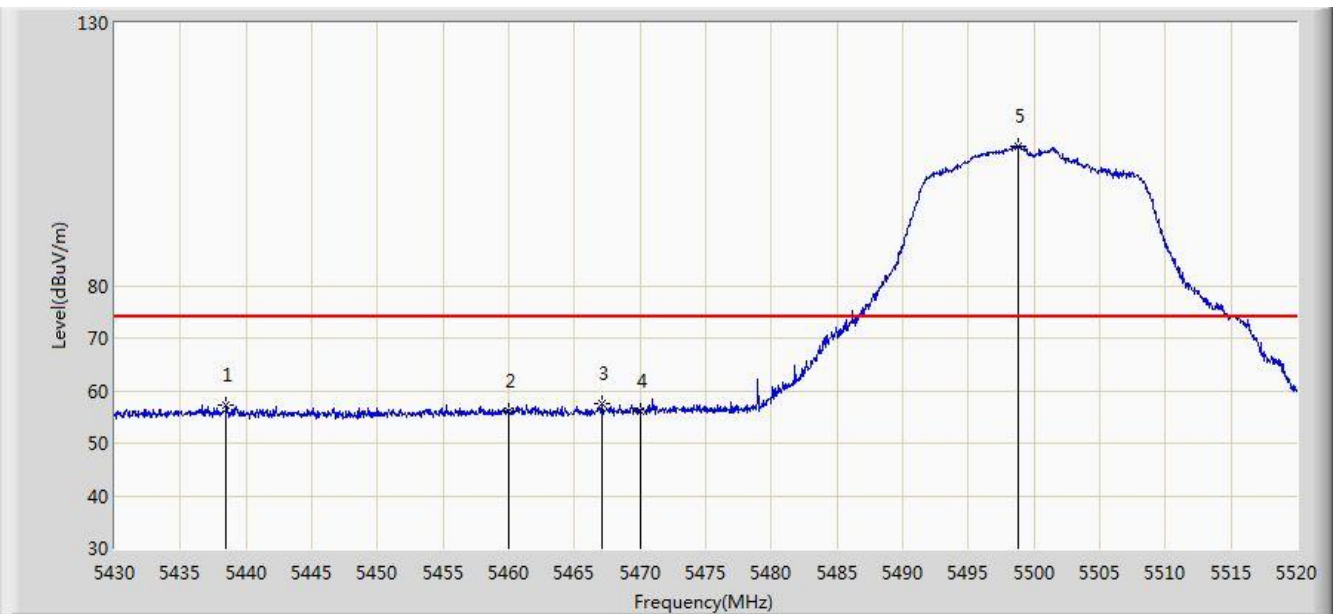

No	Flag	Mark	Frequency (MHz)	Measure Level (dBuV/m)	Reading Level (dBuV)	Over Limit (dB)	Limit (dBuV/m)	Factor (dB)	Type
1			5438.505	57.317	54.051	-16.683	74.000	3.265	PK
2			5460.000	56.024	52.831	-17.976	74.000	3.194	PK
3			5467.125	57.603	54.171	-16.397	74.000	3.432	PK
4			5470.000	56.146	52.617	-17.854	74.000	3.529	PK
5		*	5498.850	106.563	103.438	N/A	N/A	3.124	PK

Note: Measure Level (dB $\mu$ V/m) = Reading Level (dB $\mu$ V) + Factor (dB)

Factor (dB) = Cable Loss (dB) + Antenna Factor (dB/m) - Pre\_Amplifier Gain (dB)

Site: AC2	Time: 2017/12/08 - 18:47
Limit: FCC_Part15.209_RE(3m)	Engineer: Snake Ni
Probe: BBHA9120D_1-18GHz	Polarity: Horizontal
EUT: VR All-In-One Headset	Power: By Battery
Test Mode: Transmit by 802.11ac-VHT20 at Channel 5500MHz Ant 0 + 1	

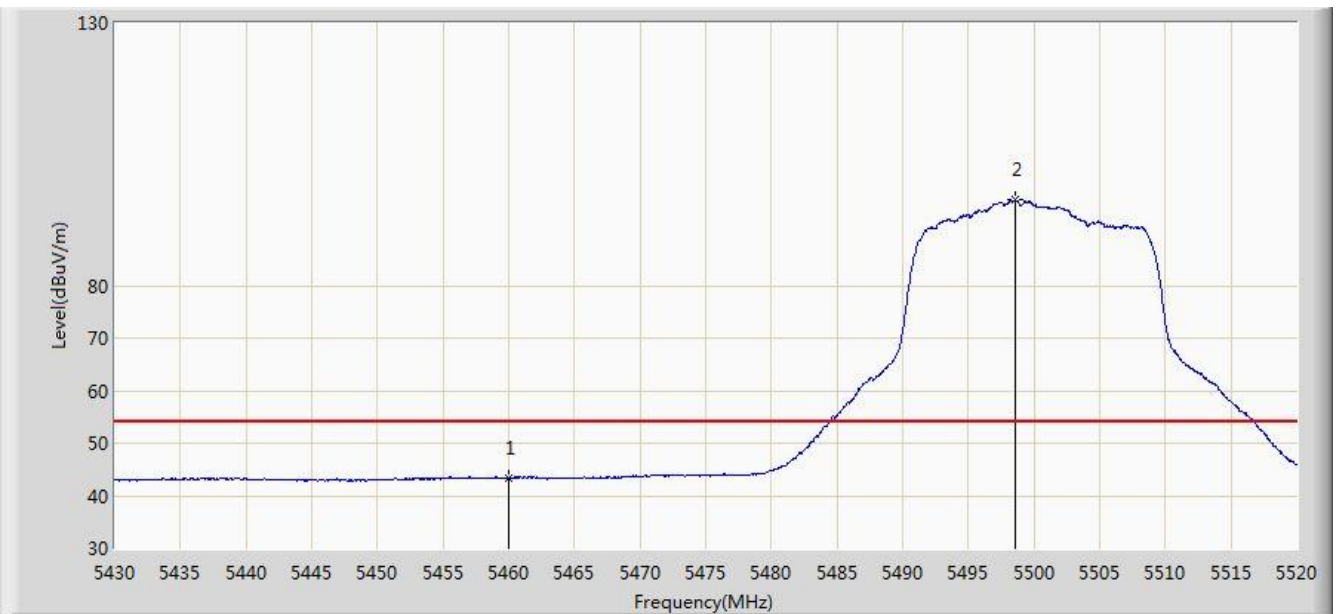

No	Flag	Mark	Frequency (MHz)	Measure Level (dBuV/m)	Reading Level (dBuV)	Over Limit (dB)	Limit (dBuV/m)	Factor (dB)	Type
1			5460.000	43.440	40.247	-10.560	54.000	3.194	AV
2		*	5498.580	96.247	93.120	N/A	N/A	3.127	AV

Note: Measure Level (dB $\mu$ V/m) = Reading Level (dB $\mu$ V) + Factor (dB)

Factor (dB) = Cable Loss (dB) + Antenna Factor (dB/m) - Pre\_Amplifier Gain (dB)

Site: AC2	Time: 2017/12/08 - 18:52
Limit: FCC_Part15.209_RE(3m)	Engineer: Snake Ni
Probe: BBHA9120D_1-18GHz	Polarity: Vertical
EUT: VR All-In-One Headset	Power: By Battery
Test Mode: Transmit by 802.11ac-VHT20 at Channel 5500MHz Ant 0 + 1	

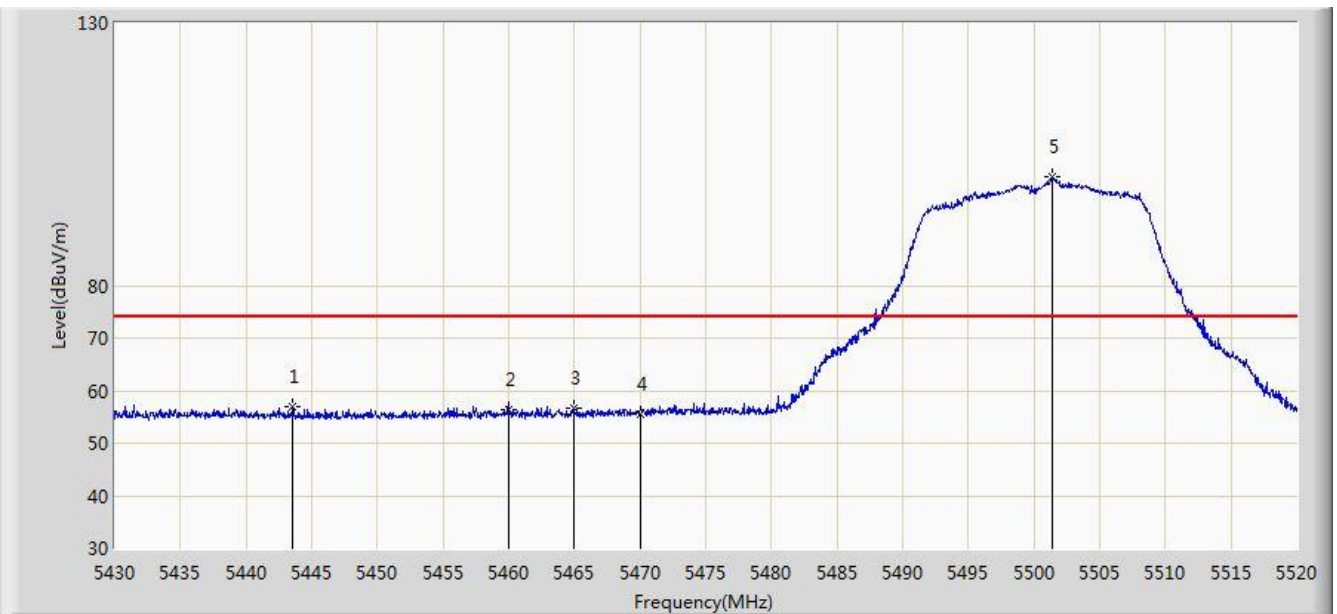

No	Flag	Mark	Frequency (MHz)	Measure Level (dBuV/m)	Reading Level (dBuV)	Over Limit (dB)	Limit (dBuV/m)	Factor (dB)	Type
1			5443.590	56.863	53.711	-17.137	74.000	3.152	PK
2			5460.000	56.342	53.149	-17.658	74.000	3.194	PK
3			5465.010	56.679	53.318	-17.321	74.000	3.362	PK
4			5470.000	55.631	52.102	-18.369	74.000	3.529	PK
5		*	5501.415	100.610	97.510	N/A	N/A	3.100	PK

Note: Measure Level (dB $\mu$ V/m) = Reading Level (dB $\mu$ V) + Factor (dB)

Factor (dB) = Cable Loss (dB) + Antenna Factor (dB/m) - Pre\_Amplifier Gain (dB)

Site: AC2	Time: 2017/12/08 - 18:56
Limit: FCC_Part15.209_RE(3m)	Engineer: Snake Ni
Probe: BBHA9120D_1-18GHz	Polarity: Vertical
EUT: VR All-In-One Headset	Power: By Battery
Test Mode: Transmit by 802.11ac-VHT20 at Channel 5500MHz Ant 0 + 1	

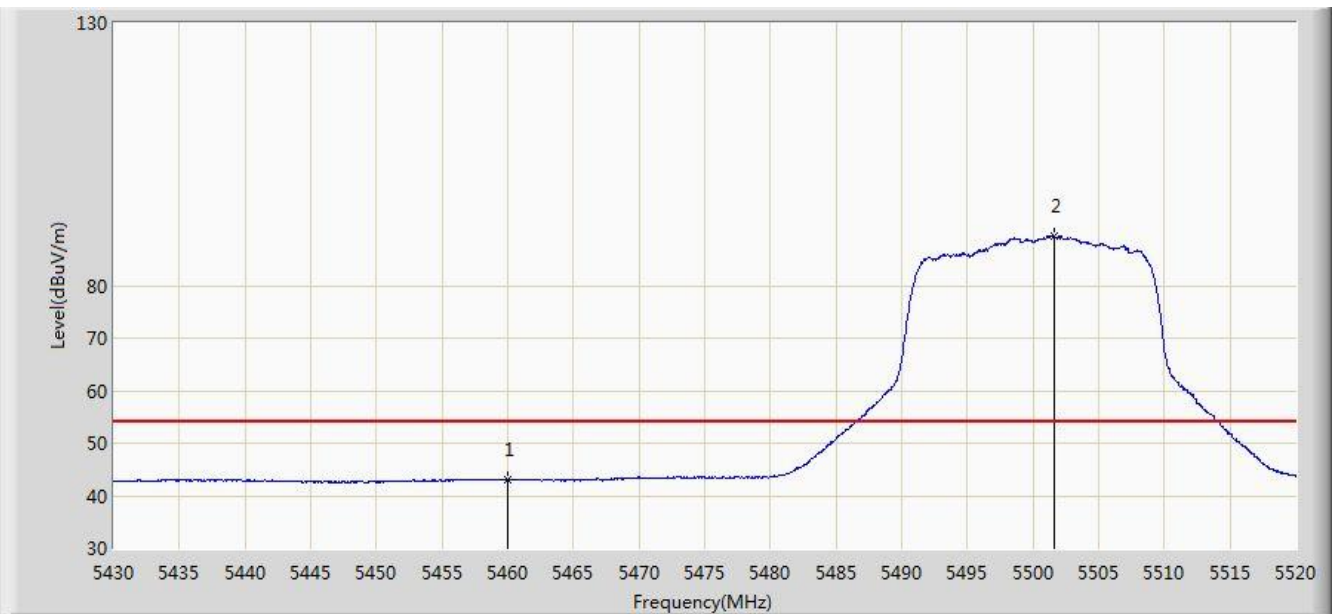

No	Flag	Mark	Frequency (MHz)	Measure Level (dBuV/m)	Reading Level (dBuV)	Over Limit (dB)	Limit (dBuV/m)	Factor (dB)	Type
1			5460.000	42.998	39.805	-11.002	54.000	3.194	AV
2		*	5501.595	89.508	86.410	N/A	N/A	3.098	AV

Note: Measure Level (dBμV/m) = Reading Level (dBμV) + Factor (dB)

Factor (dB) = Cable Loss (dB) + Antenna Factor (dB/m) - Pre\_Amplifier Gain (dB)



Site: AC2	Time: 2017/12/08 - 18:57
Limit: FCC_Part15.209_RE(3m)	Engineer: Snake Ni
Probe: BBHA9120D_1-18GHz	Polarity: Horizontal
EUT: VR All-In-One Headset	Power: By Battery
Test Mode: Transmit by 802.11ac-VHT20 at Channel 5700MHz Ant 0 + 1	

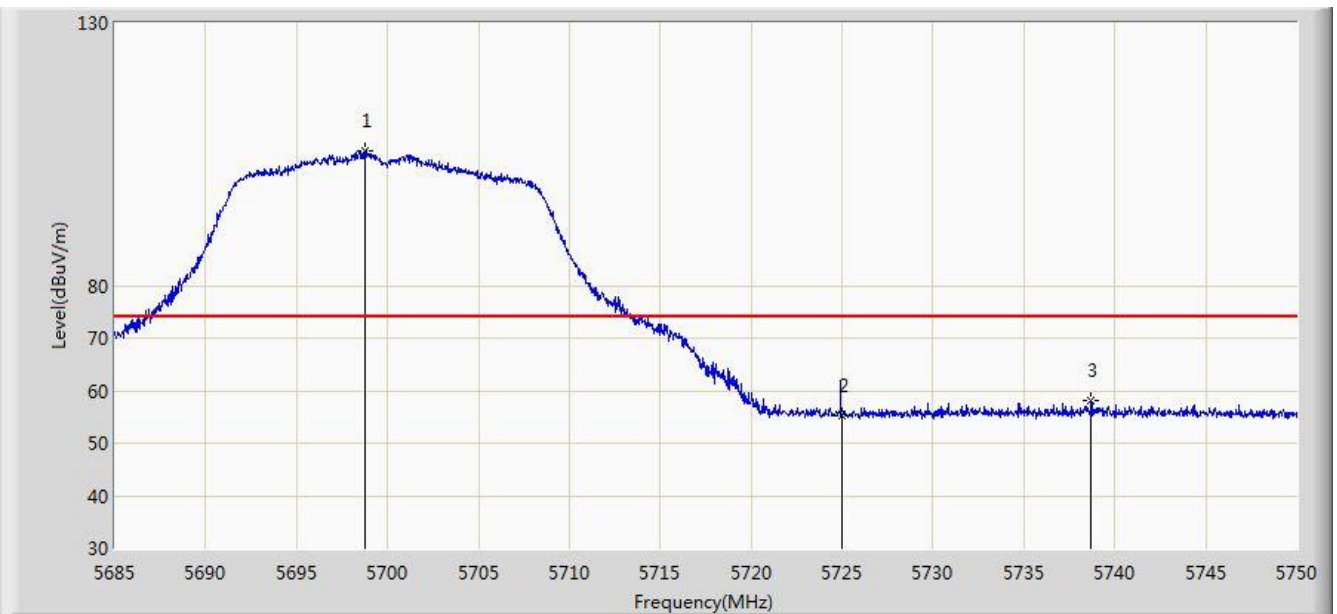

No	Flag	Mark	Frequency (MHz)	Measure Level (dBuV/m)	Reading Level (dBuV)	Over Limit (dB)	Limit (dBuV/m)	Factor (dB)	Type
1		*	5698.780	105.618	101.665	N/A	N/A	3.953	PK
2			5725.000	55.354	51.248	-18.646	74.000	4.105	PK
3			5738.690	57.999	53.718	-16.001	74.000	4.280	PK

Note: Measure Level (dBμV/m) = Reading Level (dBμV) + Factor (dB)

Factor (dB) = Cable Loss (dB) + Antenna Factor (dB/m) - Pre\_Amplifier Gain (dB)

Site: AC2	Time: 2017/12/08 - 19:00
Limit: FCC_Part15.209_RE(3m)	Engineer: Snake Ni
Probe: BBHA9120D_1-18GHz	Polarity: Horizontal
EUT: VR All-In-One Headset	Power: By Battery
Test Mode: Transmit by 802.11ac-VHT20 at Channel 5700MHz Ant 0 + 1	

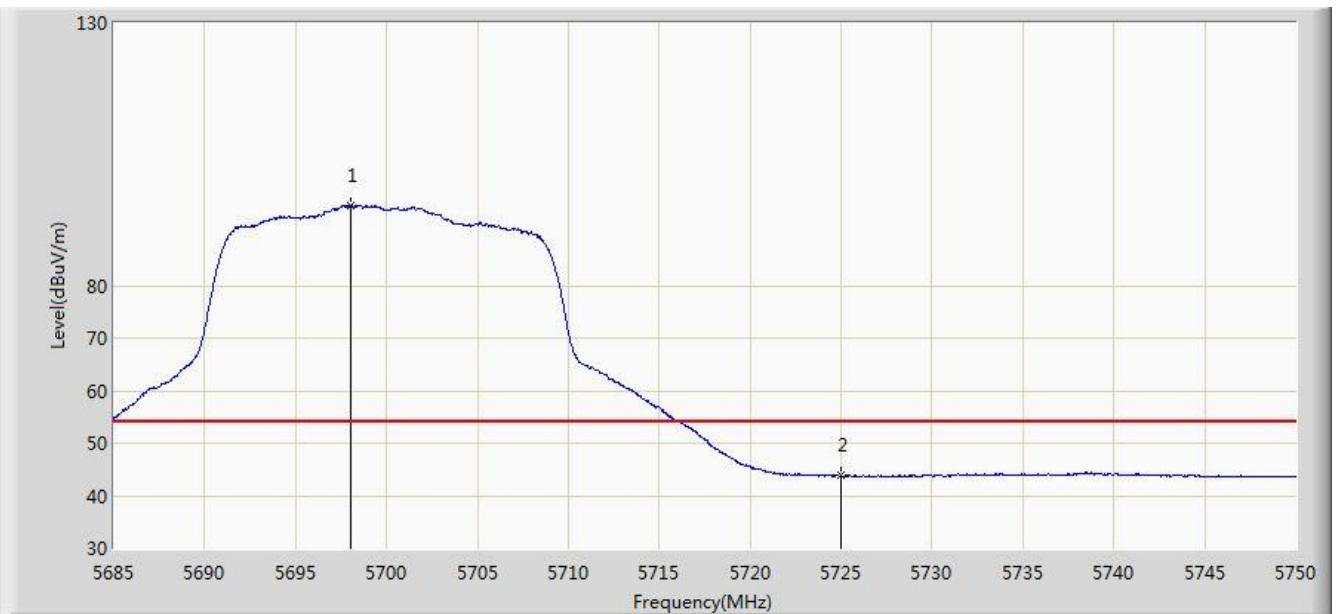

No	Flag	Mark	Frequency (MHz)	Measure Level (dBuV/m)	Reading Level (dBuV)	Over Limit (dB)	Limit (dBuV/m)	Factor (dB)	Type
1		*	5698.033	95.277	91.316	N/A	N/A	3.961	AV
2			5725.000	43.795	39.689	-10.205	54.000	4.105	AV

Note: Measure Level (dBμV/m) = Reading Level (dBμV) + Factor (dB)

Factor (dB) = Cable Loss (dB) + Antenna Factor (dB/m) - Pre\_Amplifier Gain (dB)

Site: AC2	Time: 2017/12/08 - 19:01
Limit: FCC_Part15.209_RE(3m)	Engineer: Snake Ni
Probe: BBHA9120D_1-18GHz	Polarity: Vertical
EUT: VR All-In-One Headset	Power: By Battery
Test Mode: Transmit by 802.11ac-VHT20 at Channel 5700MHz Ant 0 + 1	

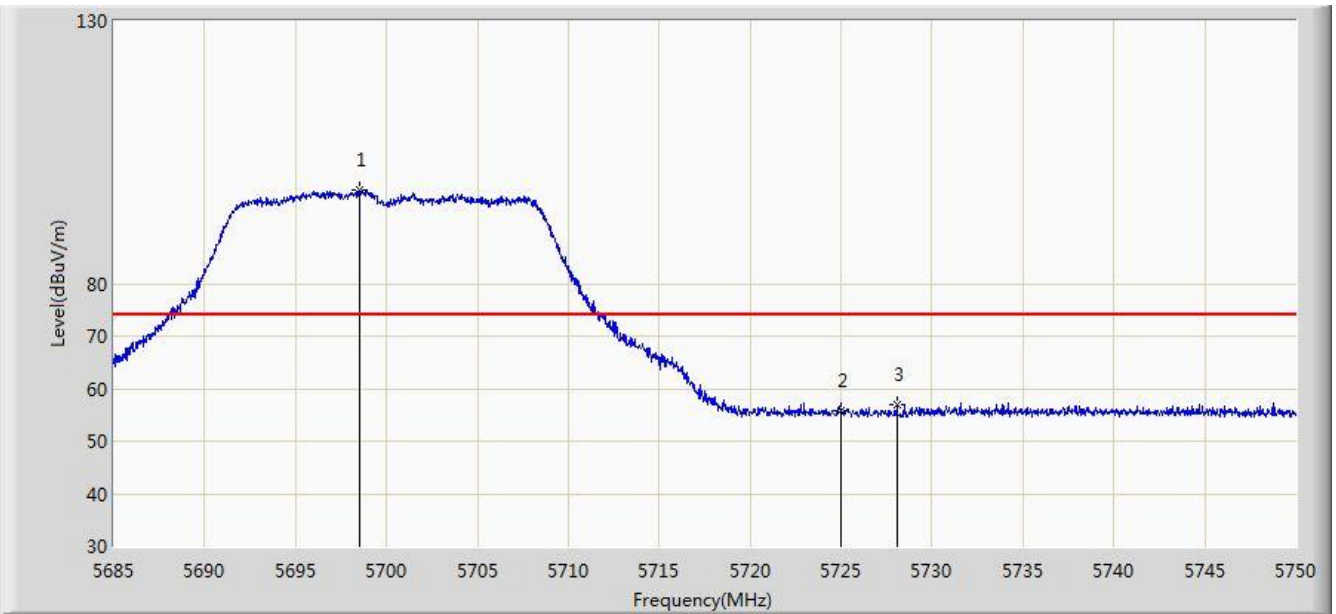

No	Flag	Mark	Frequency (MHz)	Measure Level (dBuV/m)	Reading Level (dBuV)	Over Limit (dB)	Limit (dBuV/m)	Factor (dB)	Type
1		*	5698.553	97.891	93.935	N/A	N/A	3.956	PK
2			5725.000	55.928	51.822	-18.072	74.000	4.105	PK
3			5728.095	57.003	52.820	-16.997	74.000	4.183	PK

Note: Measure Level (dB $\mu$ V/m) = Reading Level (dB $\mu$ V) + Factor (dB)

Factor (dB) = Cable Loss (dB) + Antenna Factor (dB/m) - Pre\_Amplifier Gain (dB)

Site: AC2	Time: 2017/12/08 - 19:03
Limit: FCC_Part15.209_RE(3m)	Engineer: Snake Ni
Probe: BBHA9120D_1-18GHz	Polarity: Vertical
EUT: VR All-In-One Headset	Power: By Battery
Test Mode: Transmit by 802.11ac-VHT20 at Channel 5700MHz Ant 0 + 1	

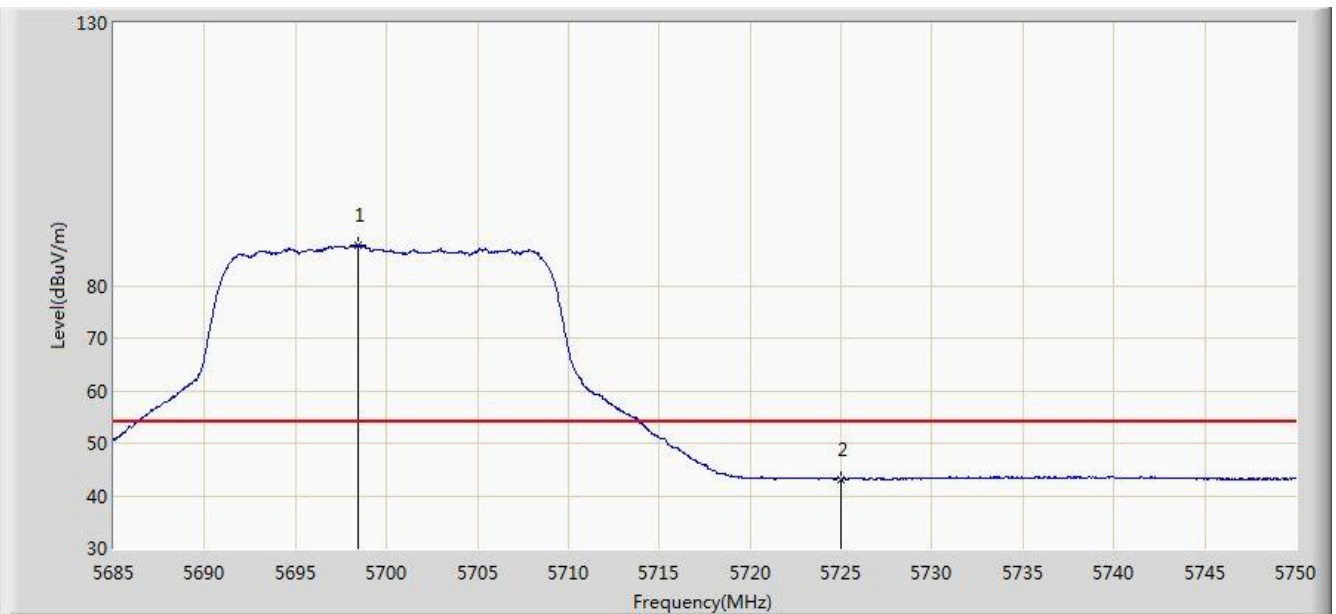

No	Flag	Mark	Frequency (MHz)	Measure Level (dBuV/m)	Reading Level (dBuV)	Over Limit (dB)	Limit (dBuV/m)	Factor (dB)	Type
1		*	5698.455	87.649	83.692	N/A	N/A	3.956	AV
2			5725.000	43.156	39.050	-10.844	54.000	4.105	AV

Note: Measure Level (dB $\mu$ V/m) = Reading Level (dB $\mu$ V) + Factor (dB)

Factor (dB) = Cable Loss (dB) + Antenna Factor (dB/m) - Pre\_Amplifier Gain (dB)

Site: AC2	Time: 2017/12/08 - 19:05
Limit: FCC_Part15.407_RE(3m)	Engineer: Snake Ni
Probe: BBHA9120D_1-18GHz	Polarity: Horizontal
EUT: VR All-In-One Headset	Power: By Battery
Test Mode: Transmit by 802.11ac-VHT20 at Channel 5745MHz Ant 0 + 1	

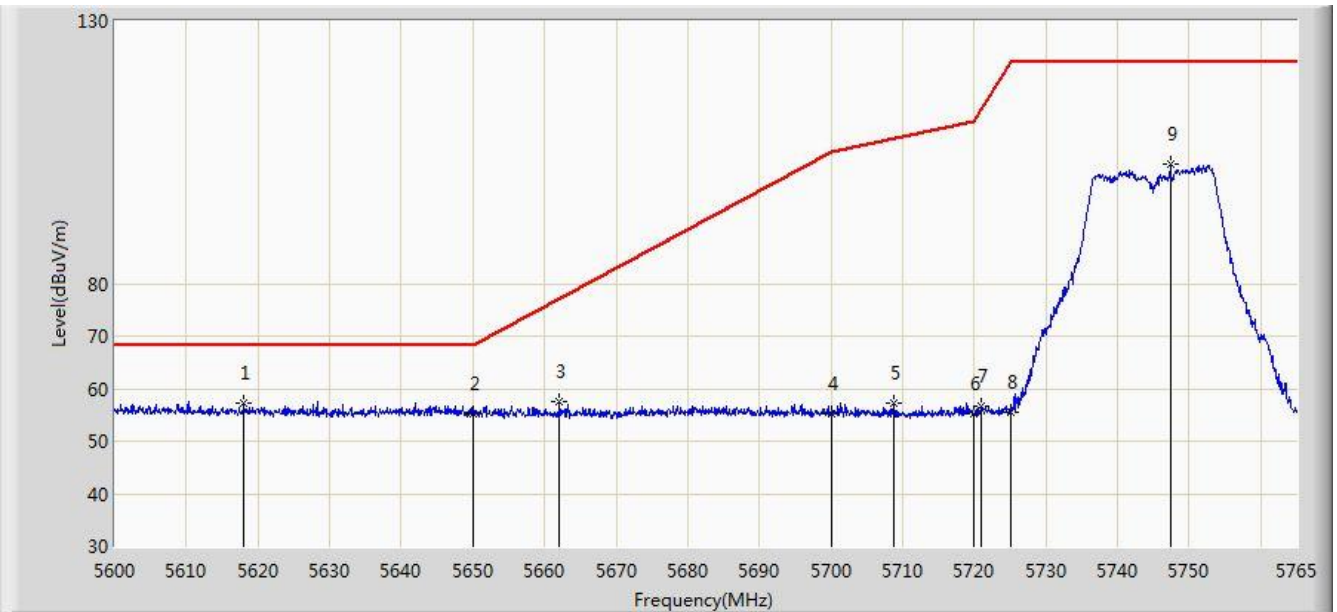

No	Flag	Mark	Frequency (MHz)	Measure Level (dBuV/m)	Reading Level (dBuV)	Over Limit (dB)	Limit (dBuV/m)	Factor (dB)	Type
1		*	5618.067	57.257	53.622	-10.943	68.200	3.635	PK
2			5650.000	55.283	51.480	-12.917	68.200	3.803	PK
3			5662.123	57.629	54.082	-19.572	77.201	3.546	PK
4			5700.000	55.135	51.195	-50.065	105.200	3.940	PK
5			5708.817	57.166	53.311	-50.505	107.671	3.855	PK
6			5720.000	55.219	51.237	-55.581	110.800	3.982	PK
7			5720.945	56.728	52.722	-56.228	112.955	4.006	PK
8			5725.000	55.466	51.360	-66.734	122.200	4.105	PK
9			5747.428	102.853	98.585	N/A	N/A	4.268	PK

Note: Measure Level (dBuV/m) = Reading Level (dBuV) + Factor (dB)

Factor (dB) = Cable Loss (dB) + Antenna Factor (dB/m) - Pre\_Amplifier Gain (dB)

Site: AC2	Time: 2017/12/08 - 19:07
Limit: FCC_Part15.407_RE(3m)	Engineer: Snake Ni
Probe: BBHA9120D_1-18GHz	Polarity: Vertical
EUT: VR All-In-One Headset	Power: By Battery
Test Mode: Transmit by 802.11ac-VHT20 at Channel 5745MHz Ant 0 + 1	

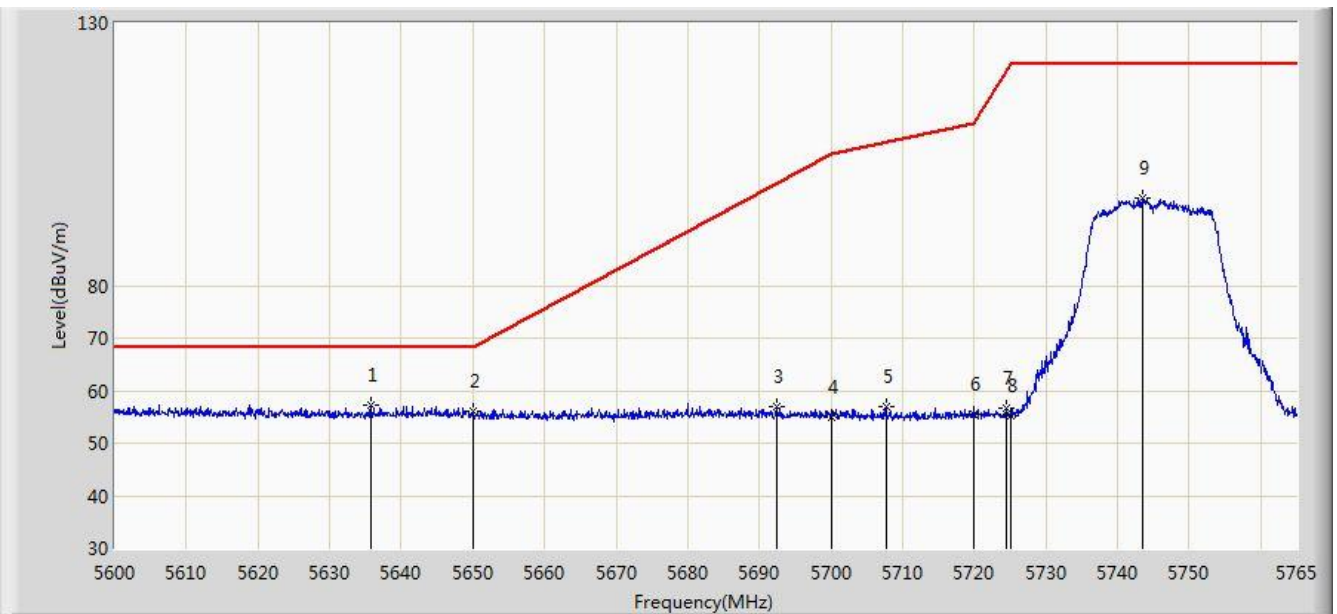

No	Flag	Mark	Frequency (MHz)	Measure Level (dBuV/m)	Reading Level (dBuV)	Over Limit (dB)	Limit (dBuV/m)	Factor (dB)	Type
1		*	5635.805	57.278	53.541	-10.922	68.200	3.737	PK
2			5650.000	55.959	52.156	-12.241	68.200	3.803	PK
3			5692.482	57.033	53.018	-42.624	99.657	4.015	PK
4			5700.000	55.058	51.118	-50.142	105.200	3.940	PK
5			5707.745	57.079	53.214	-50.292	107.371	3.865	PK
6			5720.000	55.592	51.610	-55.208	110.800	3.982	PK
7			5724.575	56.565	52.470	-64.666	121.231	4.095	PK
8			5725.000	55.320	51.214	-66.880	122.200	4.105	PK
9			5743.550	96.558	92.288	N/A	N/A	4.270	PK

Note: Measure Level (dBuV/m) = Reading Level (dBuV) + Factor (dB)

Factor (dB) = Cable Loss (dB) + Antenna Factor (dB/m) - Pre\_Amplifier Gain (dB)

Site: AC2	Time: 2017/12/08 - 19:09
Limit: FCC_Part15.407_RE(3m)	Engineer: Snake Ni
Probe: BBHA9120D_1-18GHz	Polarity: Horizontal
EUT: VR All-In-One Headset	Power: By Battery
Test Mode: Transmit by 802.11ac-VHT20 at Channel 5825MHz Ant 0 + 1	

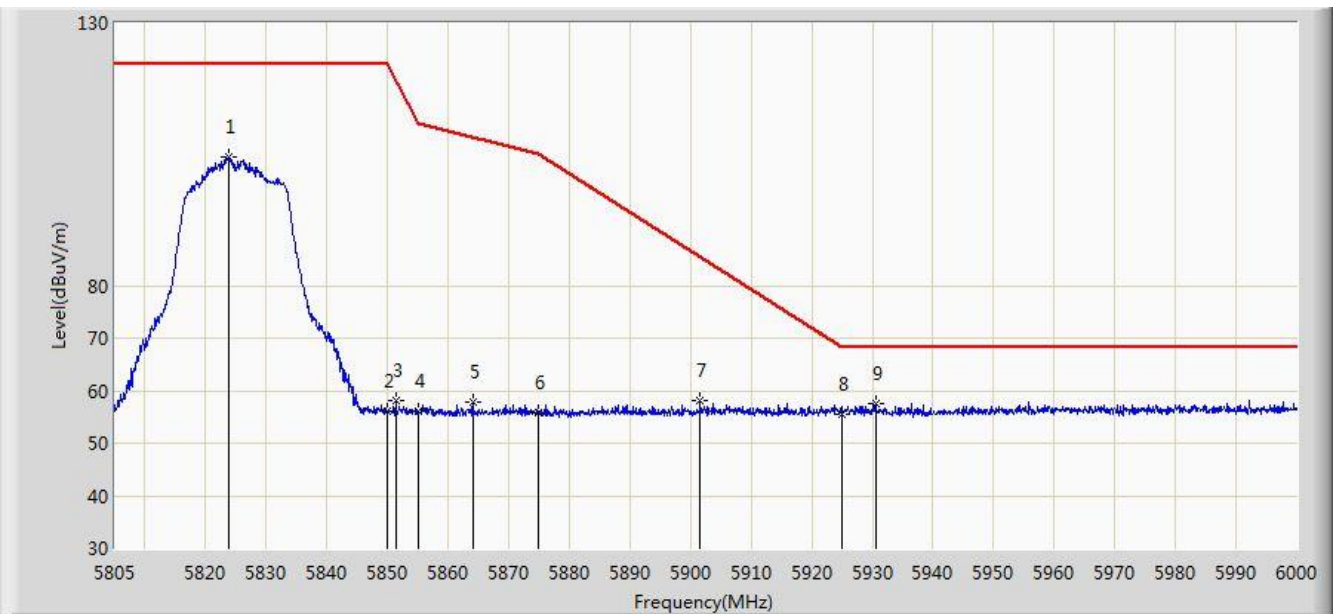

No	Flag	Mark	Frequency (MHz)	Measure Level (dBuV/m)	Reading Level (dBuV)	Over Limit (dB)	Limit (dBuV/m)	Factor (dB)	Type
1			5823.720	104.474	99.755	N/A	N/A	4.719	PK
2			5850.000	56.137	51.142	-66.063	122.200	4.995	PK
3			5851.312	58.004	53.011	-61.204	119.208	4.993	PK
4			5855.000	56.059	51.071	-54.741	110.800	4.987	PK
5			5864.085	57.817	52.840	-50.437	108.254	4.977	PK
6			5875.000	55.791	50.784	-49.409	105.200	5.008	PK
7			5901.623	58.155	52.996	-27.305	85.460	5.158	PK
8			5925.000	55.506	50.354	-12.694	68.200	5.152	PK
9		*	5930.482	57.642	52.447	-10.558	68.200	5.195	PK

Note: Measure Level (dBuV/m) = Reading Level (dBuV) + Factor (dB)

Factor (dB) = Cable Loss (dB) + Antenna Factor (dB/m) - Pre\_Amplifier Gain (dB)

Site: AC2	Time: 2017/12/08 - 19:12
Limit: FCC_Part15.407_RE(3m)	Engineer: Snake Ni
Probe: BBHA9120D_1-18GHz	Polarity: Vertical
EUT: VR All-In-One Headset	Power: By Battery
Test Mode: Transmit by 802.11ac-VHT20 at Channel 5825MHz Ant 0 + 1	

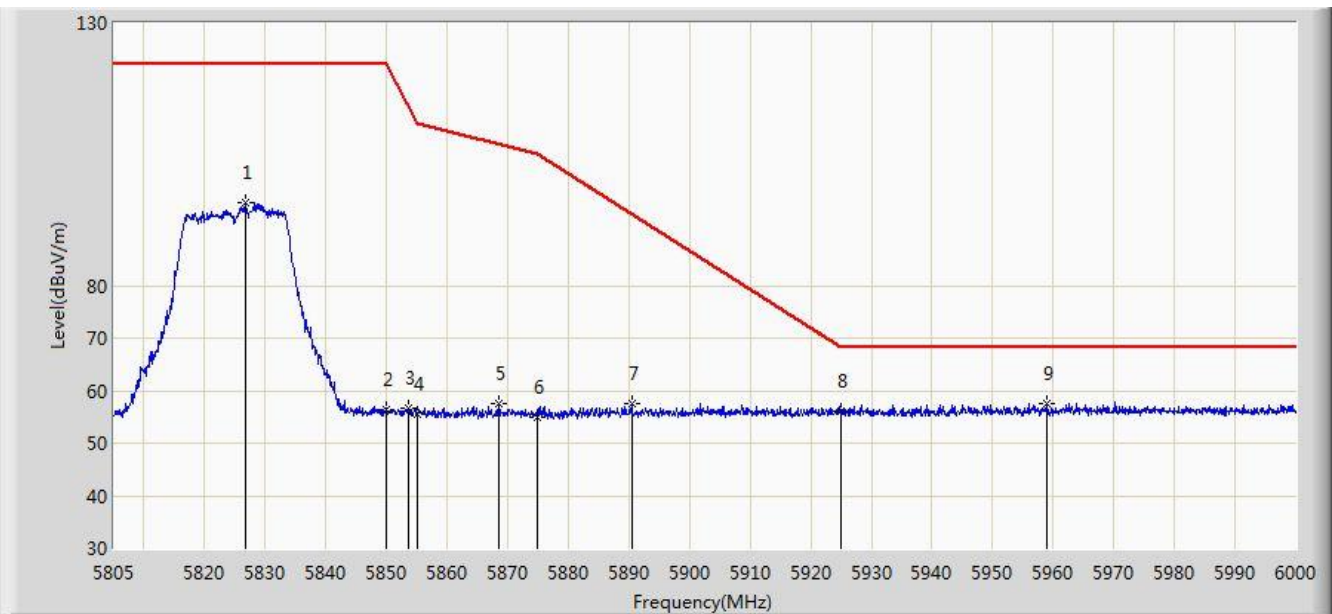

No	Flag	Mark	Frequency (MHz)	Measure Level (dBuV/m)	Reading Level (dBuV)	Over Limit (dB)	Limit (dBuV/m)	Factor (dB)	Type
1			5826.743	95.739	90.975	N/A	N/A	4.764	PK
2			5850.000	56.232	51.237	-65.968	122.200	4.995	PK
3			5853.652	56.564	51.574	-57.309	113.872	4.990	PK
4			5855.000	55.570	50.582	-55.230	110.800	4.987	PK
5			5868.473	57.496	52.518	-49.530	107.025	4.978	PK
6			5875.000	55.052	50.045	-50.148	105.200	5.008	PK
7			5890.410	57.626	52.511	-36.137	93.763	5.116	PK
8			5925.000	56.071	50.919	-12.129	68.200	5.152	PK
9		*	5958.855	57.490	52.134	-10.710	68.200	5.356	PK

Note: Measure Level (dBuV/m) = Reading Level (dBuV) + Factor (dB)

Factor (dB) = Cable Loss (dB) + Antenna Factor (dB/m) - Pre\_Amplifier Gain (dB)



Site: AC2	Time: 2017/12/08 - 19:14
Limit: FCC_Part15.209_RE(3m)	Engineer: Snake Ni
Probe: BBHA9120D_1-18GHz	Polarity: Horizontal
EUT: VR All-In-One Headset	Power: By Battery
Test Mode: Transmit by 802.11ac-VHT40 at Channel 5190MHz Ant 0 + 1	

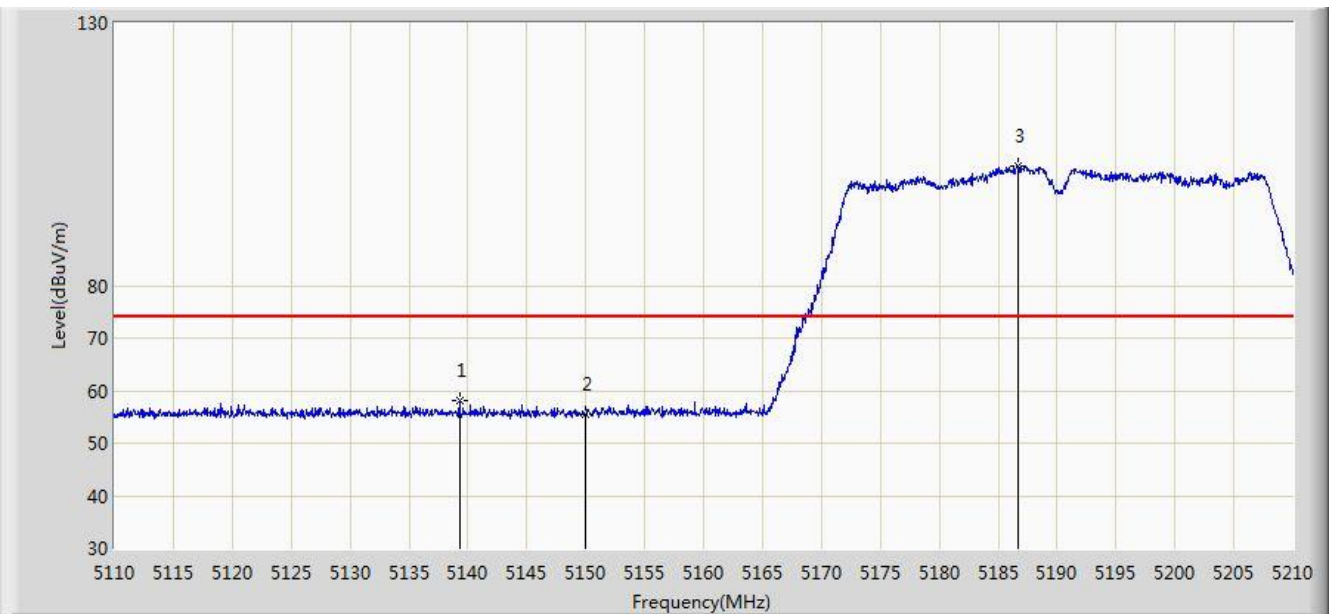

No	Flag	Mark	Frequency (MHz)	Measure Level (dBuV/m)	Reading Level (dBuV)	Over Limit (dB)	Limit (dBuV/m)	Factor (dB)	Type
1			5139.300	58.189	55.093	-15.811	74.000	3.096	PK
2			5150.000	55.365	52.295	-18.635	74.000	3.069	PK
3		*	5186.750	102.652	99.660	N/A	N/A	2.992	PK

Note: Measure Level (dB $\mu$ V/m) = Reading Level (dB $\mu$ V) + Factor (dB)

Factor (dB) = Cable Loss (dB) + Antenna Factor (dB/m) - Pre\_Amplifier Gain (dB)

Site: AC2	Time: 2017/12/08 - 19:18
Limit: FCC_Part15.209_RE(3m)	Engineer: Snake Ni
Probe: BBHA9120D_1-18GHz	Polarity: Horizontal
EUT: VR All-In-One Headset	Power: By Battery
Test Mode: Transmit by 802.11ac-VHT40 at Channel 5190MHz Ant 0 + 1	

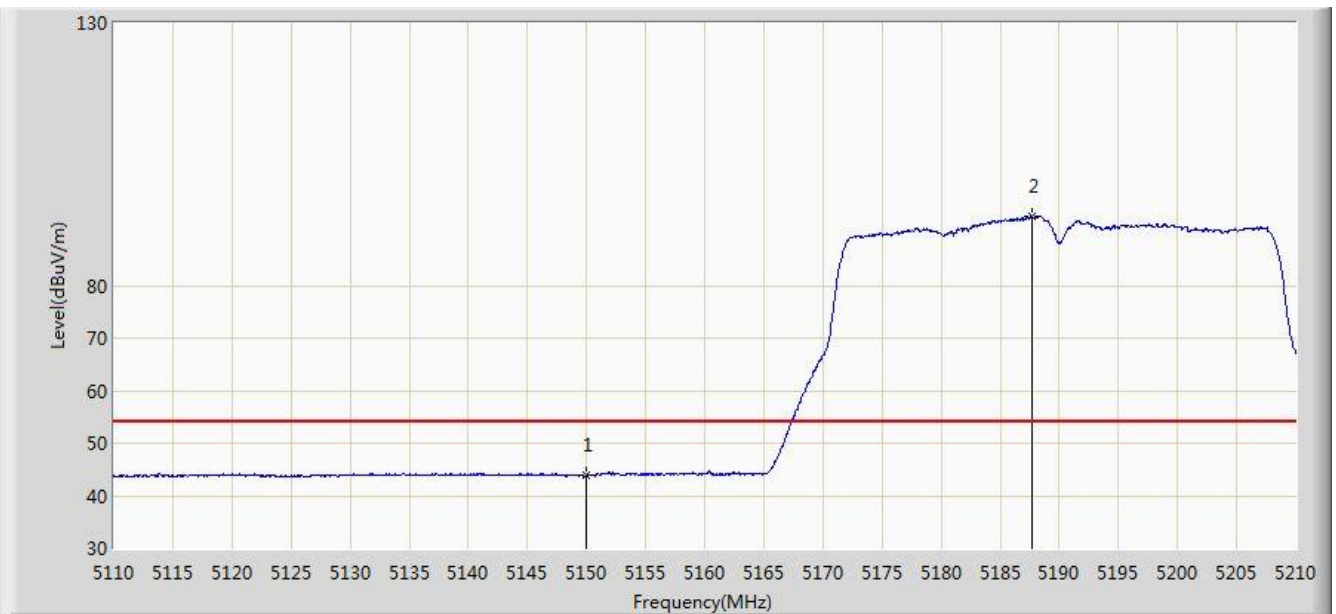

No	Flag	Mark	Frequency (MHz)	Measure Level (dBuV/m)	Reading Level (dBuV)	Over Limit (dB)	Limit (dBuV/m)	Factor (dB)	Type
1			5150.000	43.991	40.921	-10.009	54.000	3.069	AV
2		*	5187.700	93.158	90.178	N/A	N/A	2.980	AV

Note: Measure Level (dBμV/m) = Reading Level (dBμV) + Factor (dB)

Factor (dB) = Cable Loss (dB) + Antenna Factor (dB/m) - Pre\_Amplifier Gain (dB)

Site: AC2	Time: 2017/12/08 - 19:20
Limit: FCC_Part15.209_RE(3m)	Engineer: Snake Ni
Probe: BBHA9120D_1-18GHz	Polarity: Vertical
EUT: VR All-In-One Headset	Power: By Battery
Test Mode: Transmit by 802.11ac-VHT40 at Channel 5190MHz Ant 0 + 1	

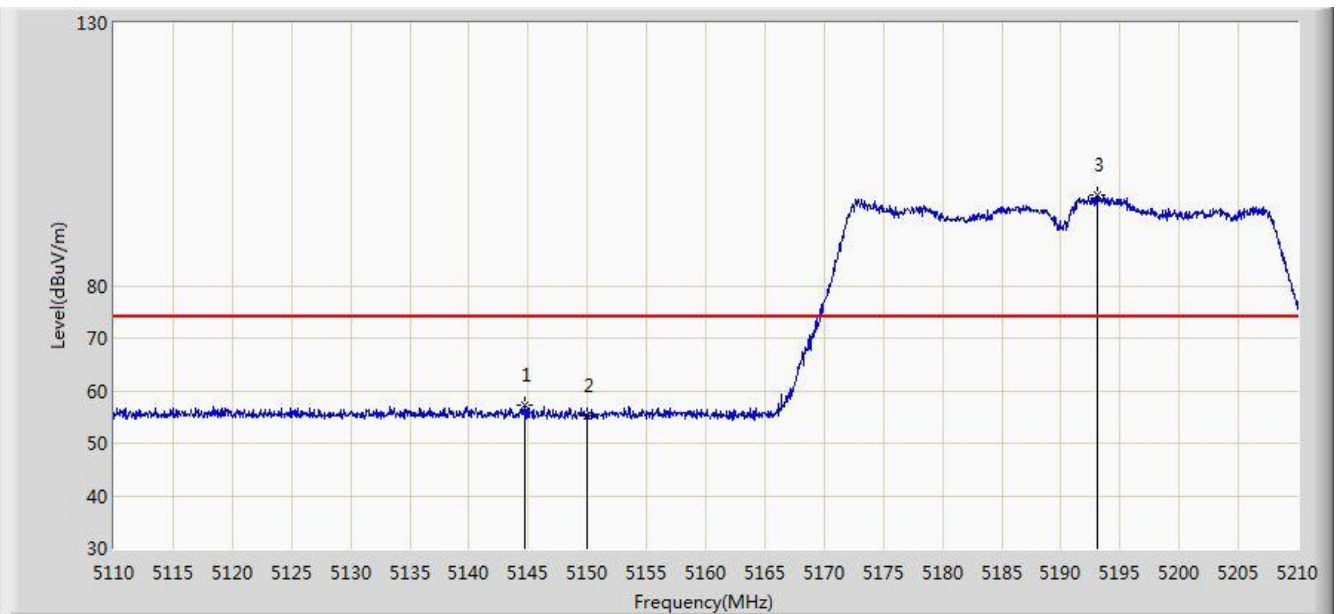

No	Flag	Mark	Frequency (MHz)	Measure Level (dBuV/m)	Reading Level (dBuV)	Over Limit (dB)	Limit (dBuV/m)	Factor (dB)	Type
1			5144.650	57.261	54.178	-16.739	74.000	3.082	PK
2			5150.000	55.244	52.174	-18.756	74.000	3.069	PK
3		*	5193.050	97.366	94.460	N/A	N/A	2.906	PK

Note: Measure Level (dB $\mu$ V/m) = Reading Level (dB $\mu$ V) + Factor (dB)

Factor (dB) = Cable Loss (dB) + Antenna Factor (dB/m) - Pre\_Amplifier Gain (dB)

Site: AC2	Time: 2017/12/08 - 19:21
Limit: FCC_Part15.209_RE(3m)	Engineer: Snake Ni
Probe: BBHA9120D_1-18GHz	Polarity: Vertical
EUT: VR All-In-One Headset	Power: By Battery
Test Mode: Transmit by 802.11ac-VHT40 at Channel 5190MHz Ant 0 + 1	

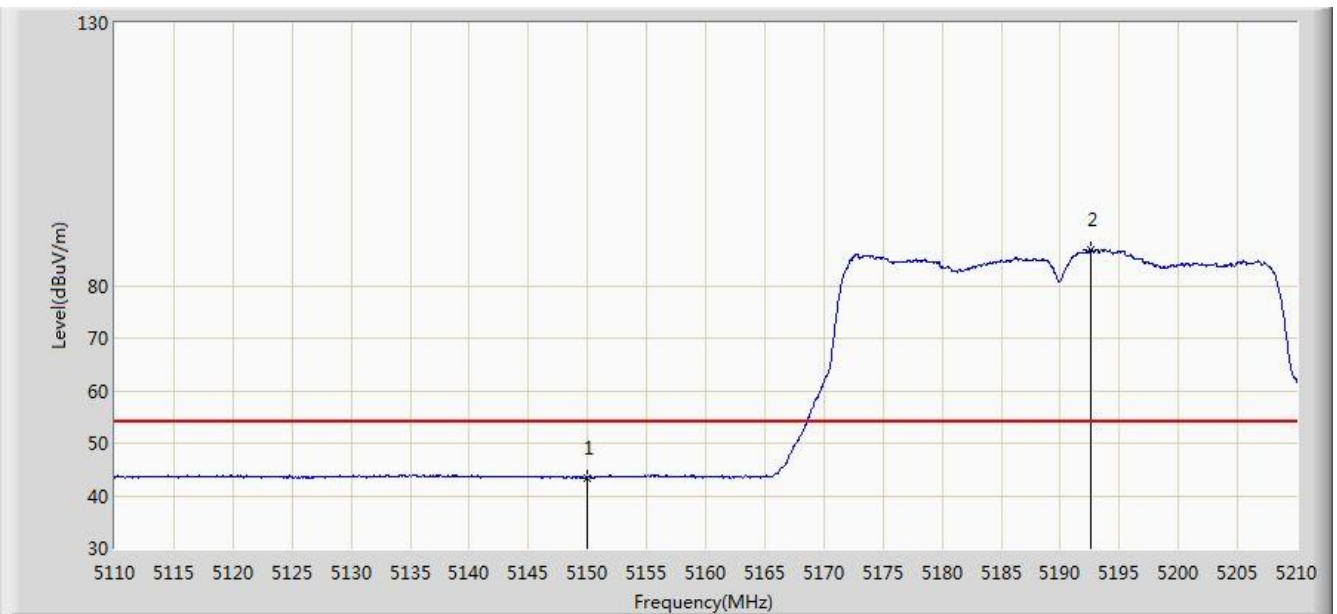

No	Flag	Mark	Frequency (MHz)	Measure Level (dBuV/m)	Reading Level (dBuV)	Over Limit (dB)	Limit (dBuV/m)	Factor (dB)	Type
1			5150.000	43.470	40.400	-10.530	54.000	3.069	AV
2		*	5192.600	86.850	83.937	N/A	N/A	2.912	AV

Note: Measure Level (dB $\mu$ V/m) = Reading Level (dB $\mu$ V) + Factor (dB)

Factor (dB) = Cable Loss (dB) + Antenna Factor (dB/m) - Pre\_Amplifier Gain (dB)

Site: AC2	Time: 2017/12/08 - 19:24
Limit: FCC_Part15.209_RE(3m)	Engineer: Snake Ni
Probe: BBHA9120D_1-18GHz	Polarity: Horizontal
EUT: VR All-In-One Headset	Power: By Battery
Test Mode: Transmit by 802.11ac-VHT40 at Channel 5310MHz Ant 0 + 1	

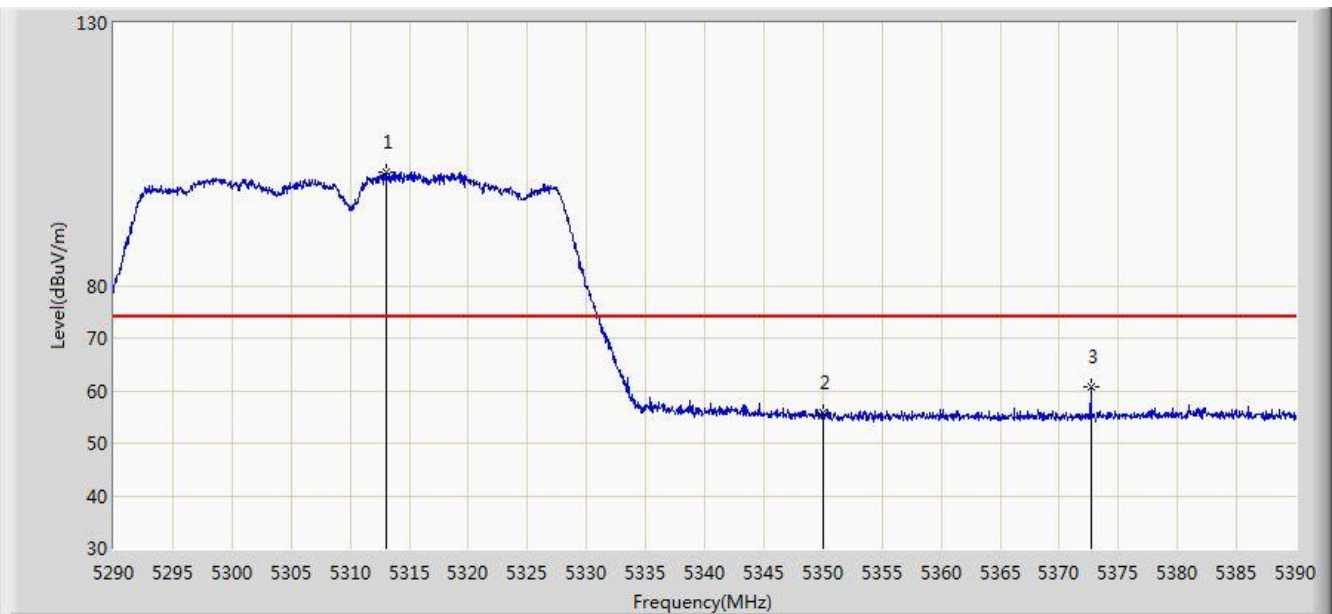

No	Flag	Mark	Frequency (MHz)	Measure Level (dBuV/m)	Reading Level (dBuV)	Over Limit (dB)	Limit (dBuV/m)	Factor (dB)	Type
1		*	5313.100	101.674	99.066	N/A	N/A	2.609	PK
2			5350.000	55.793	53.096	-18.207	74.000	2.697	PK
3			5372.650	60.761	57.864	-13.239	74.000	2.897	PK

Note: Measure Level (dBμV/m) = Reading Level (dBμV) + Factor (dB)

Factor (dB) = Cable Loss (dB) + Antenna Factor (dB/m) - Pre\_Amplifier Gain (dB)

Site: AC2	Time: 2017/12/08 - 19:27
Limit: FCC_Part15.209_RE(3m)	Engineer: Snake Ni
Probe: BBHA9120D_1-18GHz	Polarity: Horizontal
EUT: VR All-In-One Headset	Power: By Battery
Test Mode: Transmit by 802.11ac-VHT40 at Channel 5310MHz Ant 0 + 1	

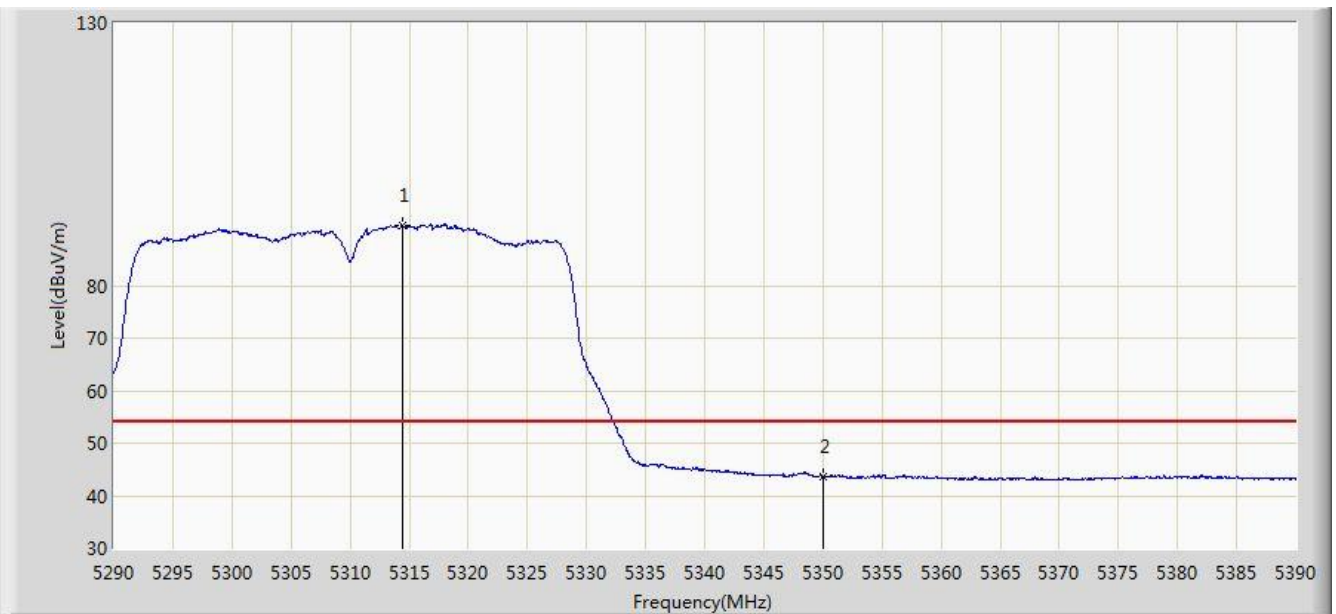

No	Flag	Mark	Frequency (MHz)	Measure Level (dBuV/m)	Reading Level (dBuV)	Over Limit (dB)	Limit (dBuV/m)	Factor (dB)	Type
1		*	5314.400	91.584	88.964	N/A	N/A	2.620	AV
2			5350.000	43.745	41.048	-10.255	54.000	2.697	AV

Note: Measure Level (dBμV/m) = Reading Level (dBμV) + Factor (dB)

Factor (dB) = Cable Loss (dB) + Antenna Factor (dB/m) - Pre\_Amplifier Gain (dB)

Site: AC2	Time: 2017/12/08 - 19:29
Limit: FCC_Part15.209_RE(3m)	Engineer: Snake Ni
Probe: BBHA9120D_1-18GHz	Polarity: Vertical
EUT: VR All-In-One Headset	Power: By Battery
Test Mode: Transmit by 802.11ac-VHT40 at Channel 5310MHz Ant 0 + 1	

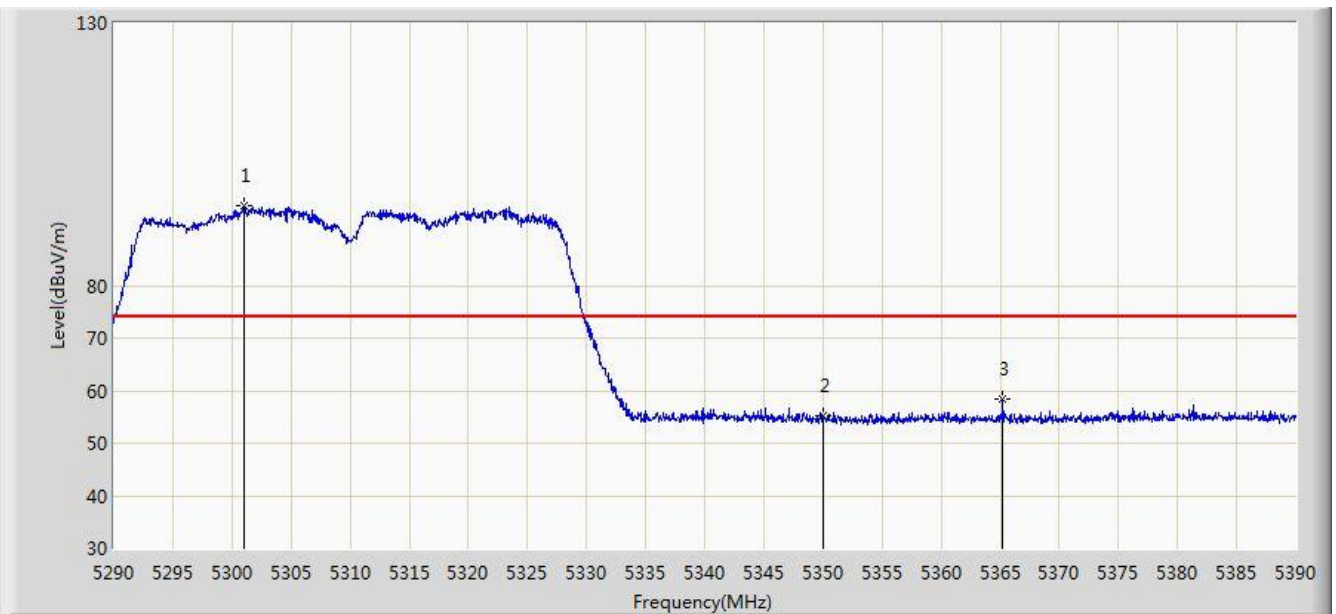

No	Flag	Mark	Frequency (MHz)	Measure Level (dBuV/m)	Reading Level (dBuV)	Over Limit (dB)	Limit (dBuV/m)	Factor (dB)	Type
1		*	5301.050	95.138	92.519	N/A	N/A	2.619	PK
2			5350.000	55.269	52.572	-18.731	74.000	2.697	PK
3			5365.250	58.429	55.693	-15.571	74.000	2.736	PK

Note: Measure Level (dBμV/m) = Reading Level (dBμV) + Factor (dB)

Factor (dB) = Cable Loss (dB) + Antenna Factor (dB/m) - Pre\_Amplifier Gain (dB)

Site: AC2	Time: 2017/12/08 - 19:30
Limit: FCC_Part15.209_RE(3m)	Engineer: Snake Ni
Probe: BBHA9120D_1-18GHz	Polarity: Vertical
EUT: VR All-In-One Headset	Power: By Battery
Test Mode: Transmit by 802.11ac-VHT40 at Channel 5310MHz Ant 0 + 1	

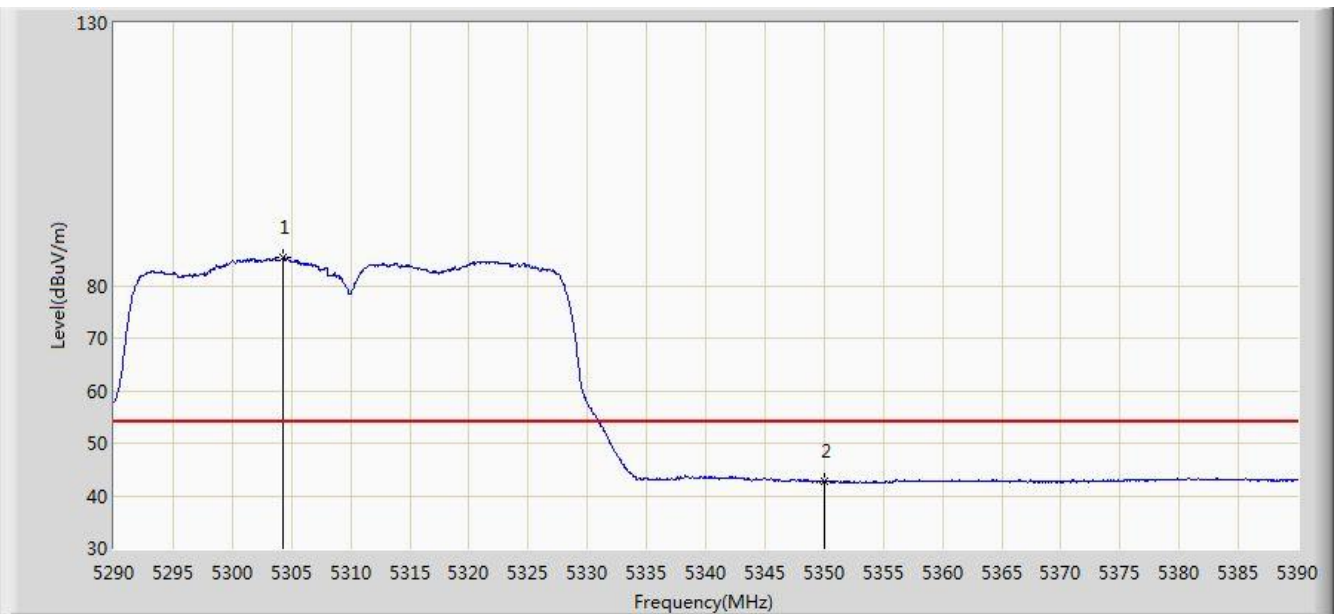

No	Flag	Mark	Frequency (MHz)	Measure Level (dBuV/m)	Reading Level (dBuV)	Over Limit (dB)	Limit (dBuV/m)	Factor (dB)	Type
1		*	5304.250	85.310	82.695	N/A	N/A	2.614	AV
2			5350.000	42.762	40.065	-11.238	54.000	2.697	AV

Note: Measure Level (dB $\mu$ V/m) = Reading Level (dB $\mu$ V) + Factor (dB)

Factor (dB) = Cable Loss (dB) + Antenna Factor (dB/m) - Pre\_Amplifier Gain (dB)



Site: AC2	Time: 2017/12/08 - 19:32
Limit: FCC_Part15.209_RE(3m)	Engineer: Snake Ni
Probe: BBHA9120D_1-18GHz	Polarity: Horizontal
EUT: VR All-In-One Headset	Power: By Battery
Test Mode: Transmit by 802.11ac-VHT40 at Channel 5510MHz Ant 0 + 1	

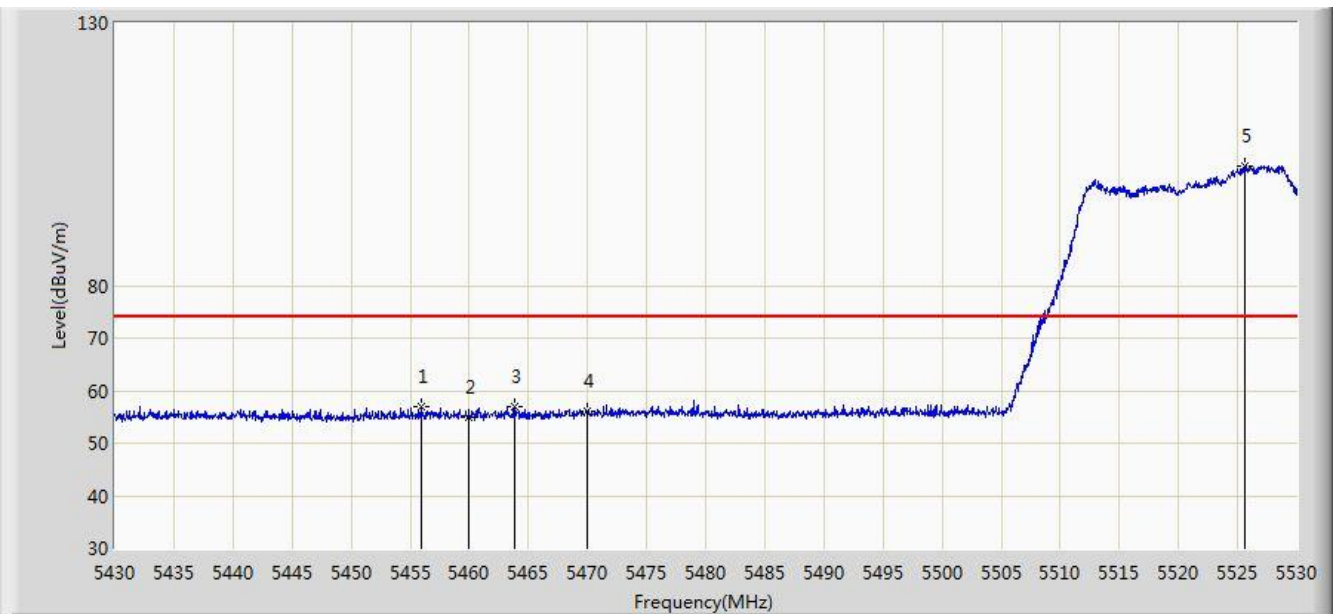

No	Flag	Mark	Frequency (MHz)	Measure Level (dBuV/m)	Reading Level (dBuV)	Over Limit (dB)	Limit (dBuV/m)	Factor (dB)	Type
1			5455.900	56.973	53.917	-17.027	74.000	3.056	PK
2			5460.000	55.011	51.818	-18.989	74.000	3.194	PK
3			5463.800	56.882	53.561	-17.118	74.000	3.321	PK
4			5470.000	56.029	52.500	-17.971	74.000	3.529	PK
5		*	5525.650	102.723	99.267	N/A	N/A	3.456	PK

Note: Measure Level (dB $\mu$ V/m) = Reading Level (dB $\mu$ V) + Factor (dB)

Factor (dB) = Cable Loss (dB) + Antenna Factor (dB/m) - Pre\_Amplifier Gain (dB)

Site: AC2	Time: 2017/12/08 - 19:34
Limit: FCC_Part15.209_RE(3m)	Engineer: Snake Ni
Probe: BBHA9120D_1-18GHz	Polarity: Horizontal
EUT: VR All-In-One Headset	Power: By Battery
Test Mode: Transmit by 802.11ac-VHT40 at Channel 5510MHz Ant 0 + 1	

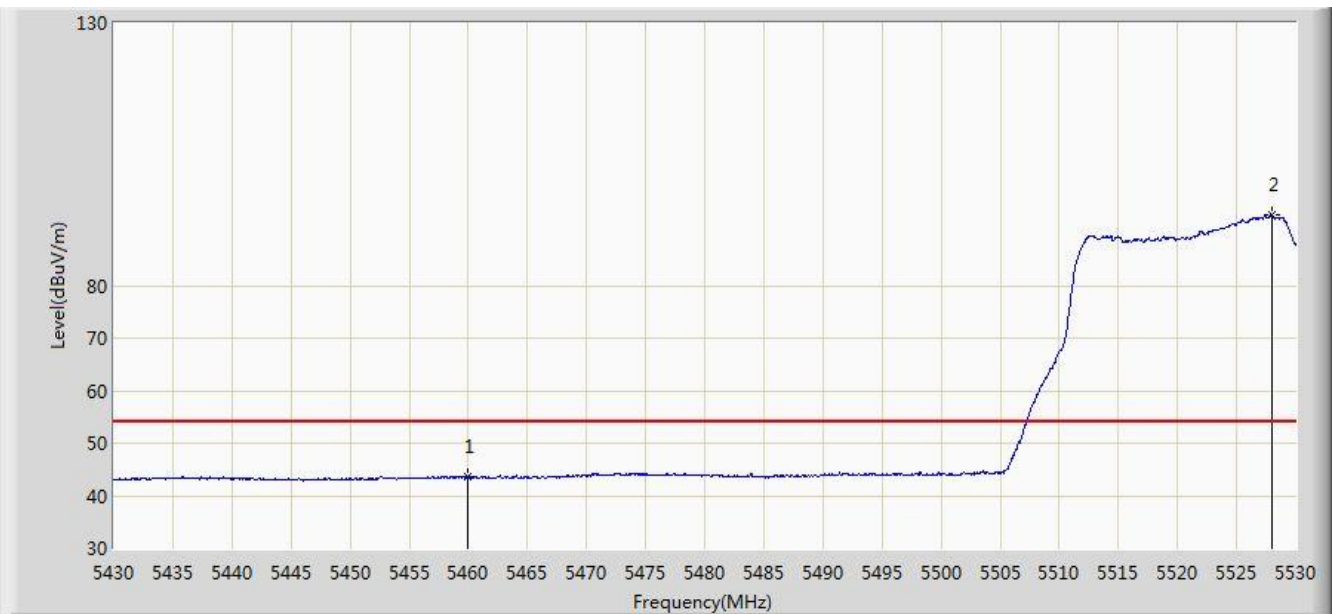

N	Fl	M	Frequency (MHz)	Measure Level (dBuV/m)	Reading Level (dBuV)	Over Limit (dB)	Limit (dBuV/m)	Factor (dB)	Type
1			5460.000	43.492	40.299	-10.508	54.000	3.194	AV
2		*	5528.000	93.421	89.987	N/A	N/A	3.433	AV

Note: Measure Level (dBμV/m) = Reading Level (dBμV) + Factor (dB)

Factor (dB) = Cable Loss (dB) + Antenna Factor (dB/m) - Pre\_Amplifier Gain (dB)

Site: AC2	Time: 2017/12/08 - 19:35
Limit: FCC_Part15.209_RE(3m)	Engineer: Snake Ni
Probe: BBHA9120D_1-18GHz	Polarity: Vertical
EUT: VR All-In-One Headset	Power: By Battery
Test Mode: Transmit by 802.11ac-VHT40 at Channel 5510MHz Ant 0 + 1	

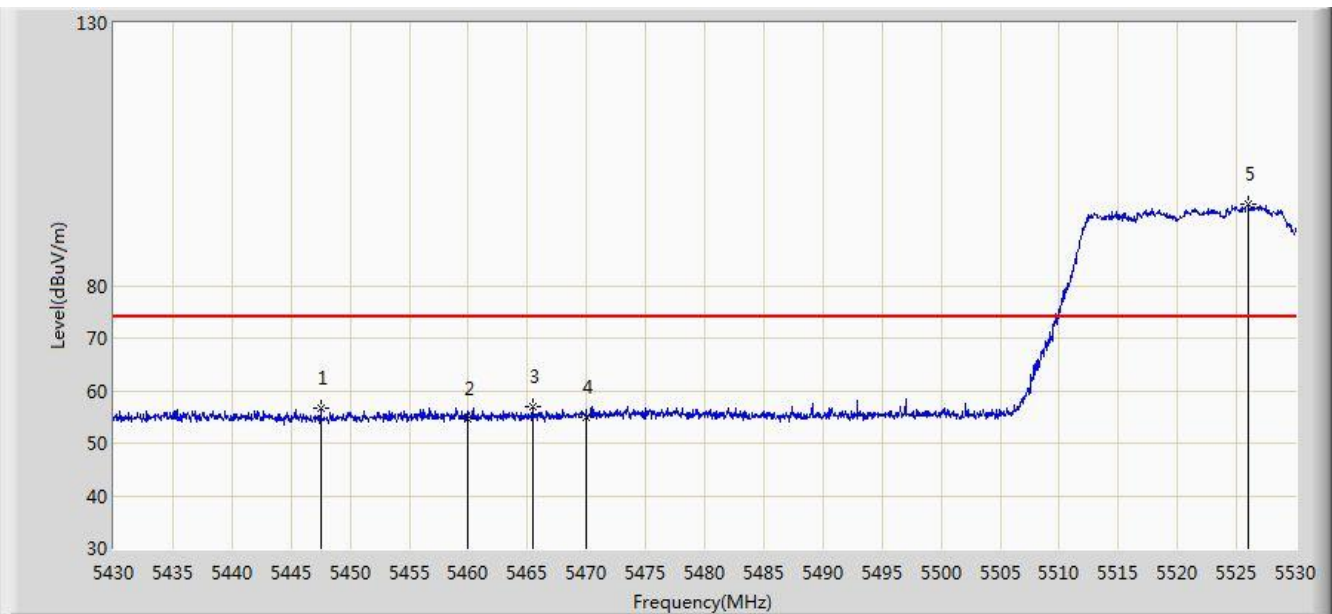

No	Flag	Mark	Frequency (MHz)	Measure Level (dBuV/m)	Reading Level (dBuV)	Over Limit (dB)	Limit (dBuV/m)	Factor (dB)	Type
1			5447.500	56.653	53.588	-17.347	74.000	3.064	PK
2			5460.000	54.733	51.540	-19.267	74.000	3.194	PK
3			5465.450	56.879	53.503	-17.121	74.000	3.377	PK
4			5470.000	54.855	51.326	-19.145	74.000	3.529	PK
5		*	5526.000	95.564	92.112	N/A	N/A	3.452	PK

Note: Measure Level (dBμV/m) = Reading Level (dBμV) + Factor (dB)

Factor (dB) = Cable Loss (dB) + Antenna Factor (dB/m) - Pre\_Amplifier Gain (dB)

Site: AC2	Time: 2017/12/08 - 19:38
Limit: FCC_Part15.209_RE(3m)	Engineer: Snake Ni
Probe: BBHA9120D_1-18GHz	Polarity: Vertical
EUT: VR All-In-One Headset	Power: By Battery
Test Mode: Transmit by 802.11ac-VHT40 at Channel 5510MHz Ant 0 + 1	

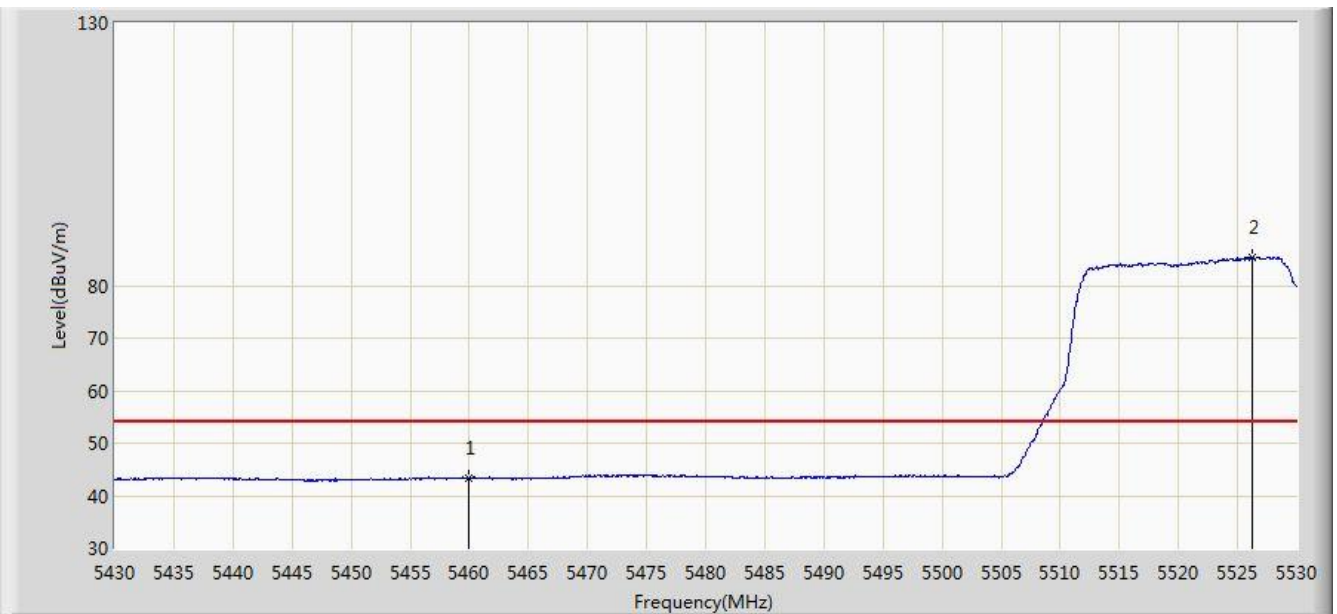

No	Flag	Mark	Frequency (MHz)	Measure Level (dBuV/m)	Reading Level (dBuV)	Over Limit (dB)	Limit (dBuV/m)	Factor (dB)	Type
1			5460.000	43.320	40.127	-10.680	54.000	3.194	AV
2		*	5526.300	85.432	81.982	N/A	N/A	3.450	AV

Note: Measure Level (dB $\mu$ V/m) = Reading Level (dB $\mu$ V) + Factor (dB)

Factor (dB) = Cable Loss (dB) + Antenna Factor (dB/m) - Pre\_Amplifier Gain (dB)

Site: AC2	Time: 2017/12/08 - 19:40
Limit: FCC_Part15.209_RE(3m)	Engineer: Snake Ni
Probe: BBHA9120D_1-18GHz	Polarity: Horizontal
EUT: VR All-In-One Headset	Power: By Battery
Test Mode: Transmit by 802.11ac-VHT40 at Channel 5670MHz Ant 0 + 1	

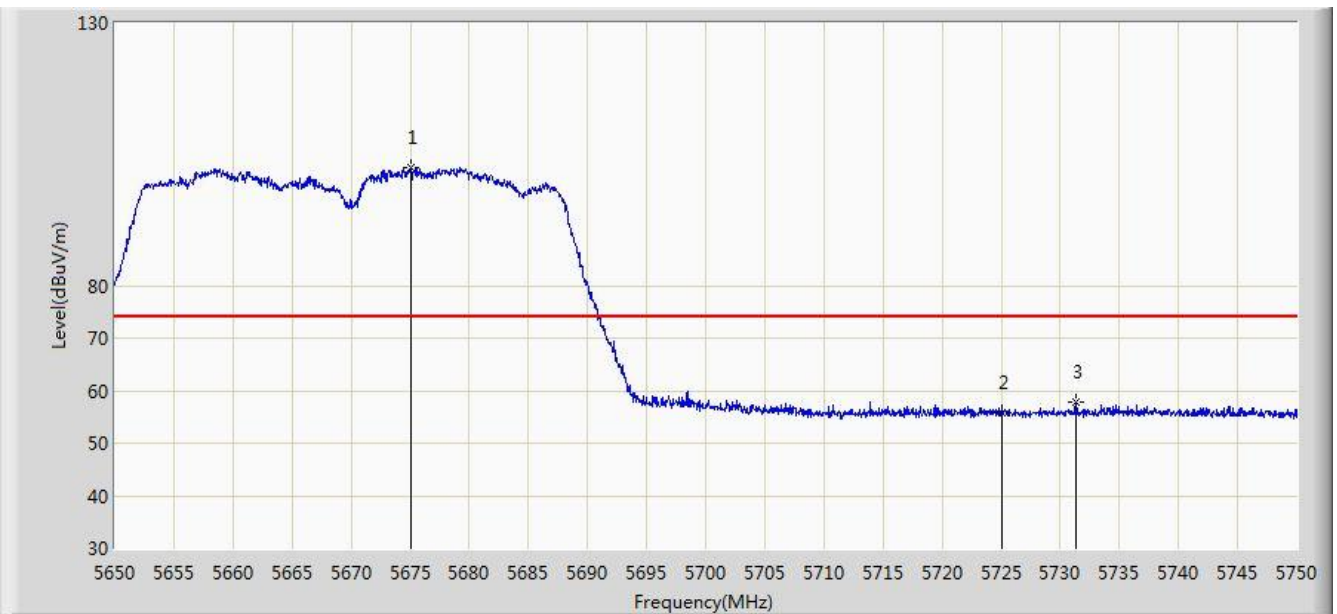

No	Flag	Mark	Frequency (MHz)	Measure Level (dBuV/m)	Reading Level (dBuV)	Over Limit (dB)	Limit (dBuV/m)	Factor (dB)	Type
1		*	5675.000	102.425	98.555	N/A	N/A	3.870	PK
2			5725.000	55.708	51.602	-18.292	74.000	4.105	PK
3			5731.300	57.948	53.684	-16.052	74.000	4.264	PK

Note: Measure Level (dB $\mu$ V/m) = Reading Level (dB $\mu$ V) + Factor (dB)

Factor (dB) = Cable Loss (dB) + Antenna Factor (dB/m) - Pre\_Amplifier Gain (dB)

Site: AC2	Time: 2017/12/08 - 19:43
Limit: FCC_Part15.209_RE(3m)	Engineer: Snake Ni
Probe: BBHA9120D_1-18GHz	Polarity: Horizontal
EUT: VR All-In-One Headset	Power: By Battery
Test Mode: Transmit by 802.11ac-VHT40 at Channel 5670MHz Ant 0 + 1	

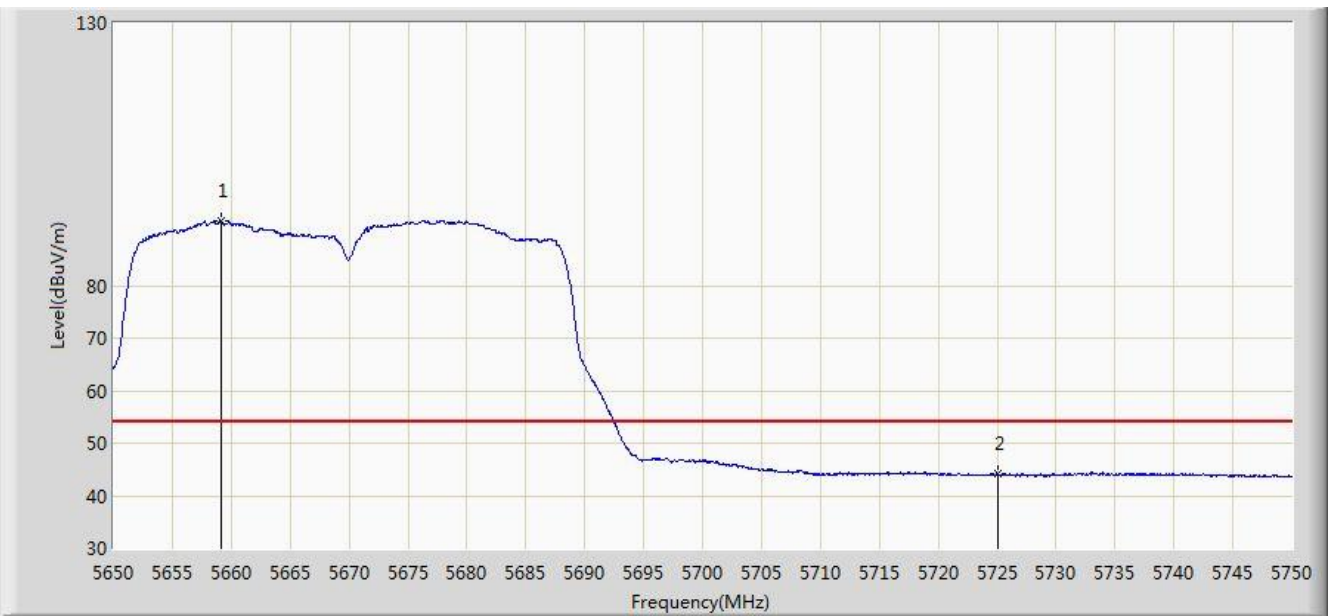

No	Flag	Mark	Frequency (MHz)	Measure Level (dBuV/m)	Reading Level (dBuV)	Over Limit (dB)	Limit (dBuV/m)	Factor (dB)	Type
1		*	5659.100	92.361	88.757	N/A	N/A	3.605	AV
2			5725.000	44.062	39.956	-9.938	54.000	4.105	AV

Note: Measure Level (dBμV/m) = Reading Level (dBμV) + Factor (dB)

Factor (dB) = Cable Loss (dB) + Antenna Factor (dB/m) - Pre\_Amplifier Gain (dB)

Site: AC2	Time: 2017/12/08 - 19:44
Limit: FCC_Part15.209_RE(3m)	Engineer: Snake Ni
Probe: BBHA9120D_1-18GHz	Polarity: Vertical
EUT: VR All-In-One Headset	Power: By Battery
Test Mode: Transmit by 802.11ac-VHT40 at Channel 5670MHz Ant 0 + 1	

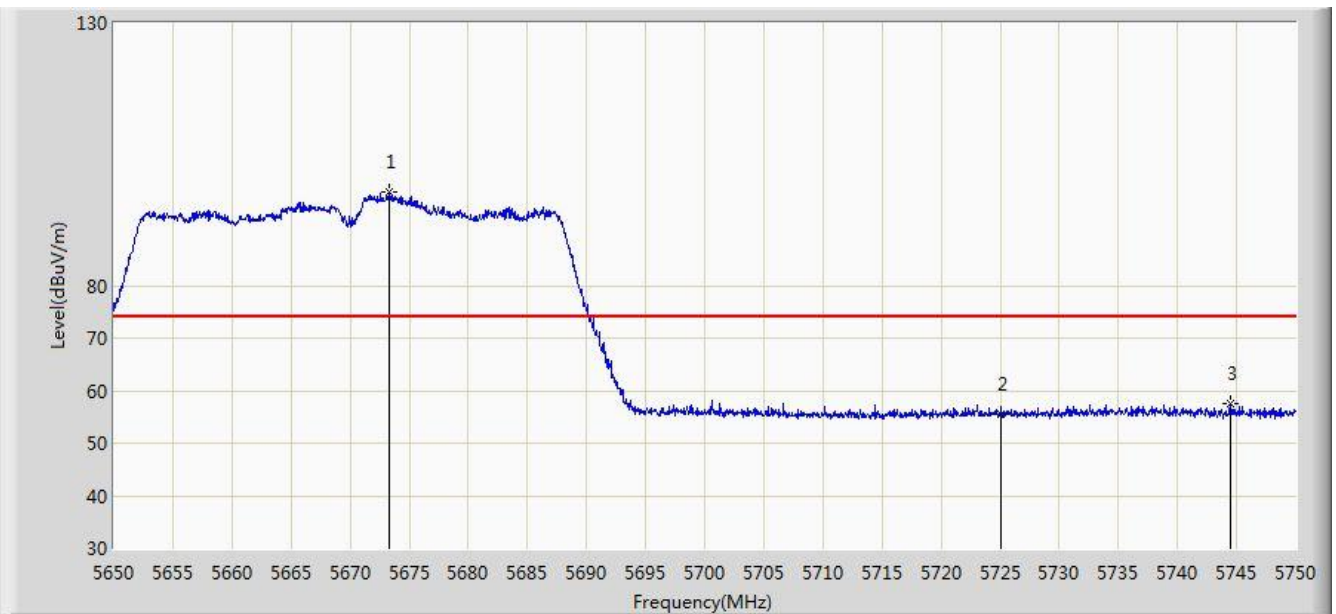

No	Flag	Mark	Frequency (MHz)	Measure Level (dBuV/m)	Reading Level (dBuV)	Over Limit (dB)	Limit (dBuV/m)	Factor (dB)	Type
1		*	5673.250	97.689	93.865	N/A	N/A	3.824	PK
2			5725.000	55.577	51.471	-18.423	74.000	4.105	PK
3			5744.450	57.617	53.347	-16.383	74.000	4.269	PK

Note: Measure Level (dBμV/m) = Reading Level (dBμV) + Factor (dB)

Factor (dB) = Cable Loss (dB) + Antenna Factor (dB/m) - Pre\_Amplifier Gain (dB)

Site: AC2	Time: 2017/12/08 - 19:46
Limit: FCC_Part15.209_RE(3m)	Engineer: Snake Ni
Probe: BBHA9120D_1-18GHz	Polarity: Vertical
EUT: VR All-In-One Headset	Power: By Battery
Test Mode: Transmit by 802.11ac-VHT40 at Channel 5670MHz Ant 0 + 1	

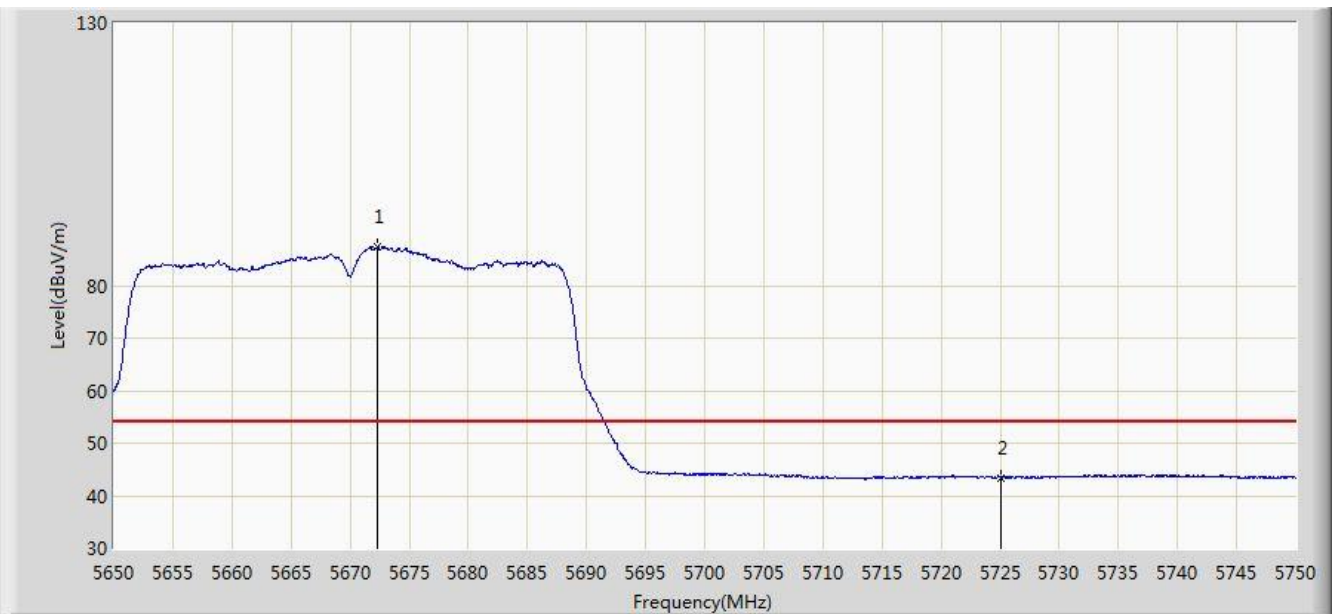

No	Flag	Mark	Frequency (MHz)	Measure Level (dBuV/m)	Reading Level (dBuV)	Over Limit (dB)	Limit (dBuV/m)	Factor (dB)	Type
1		*	5672.350	87.310	83.510	N/A	N/A	3.800	AV
2			5725.000	43.419	39.313	-10.581	54.000	4.105	AV

Note: Measure Level (dBμV/m) = Reading Level (dBμV) + Factor (dB)

Factor (dB) = Cable Loss (dB) + Antenna Factor (dB/m) - Pre\_Amplifier Gain (dB)



Site: AC2	Time: 2017/12/08 - 19:48
Limit: FCC_Part15.407_RE(3m)	Engineer: Snake Ni
Probe: BBHA9120D_1-18GHz	Polarity: Horizontal
EUT: VR All-In-One Headset	Power: By Battery
Test Mode: Transmit by 802.11ac-VHT40 at Channel 5755MHz Ant 0 + 1	

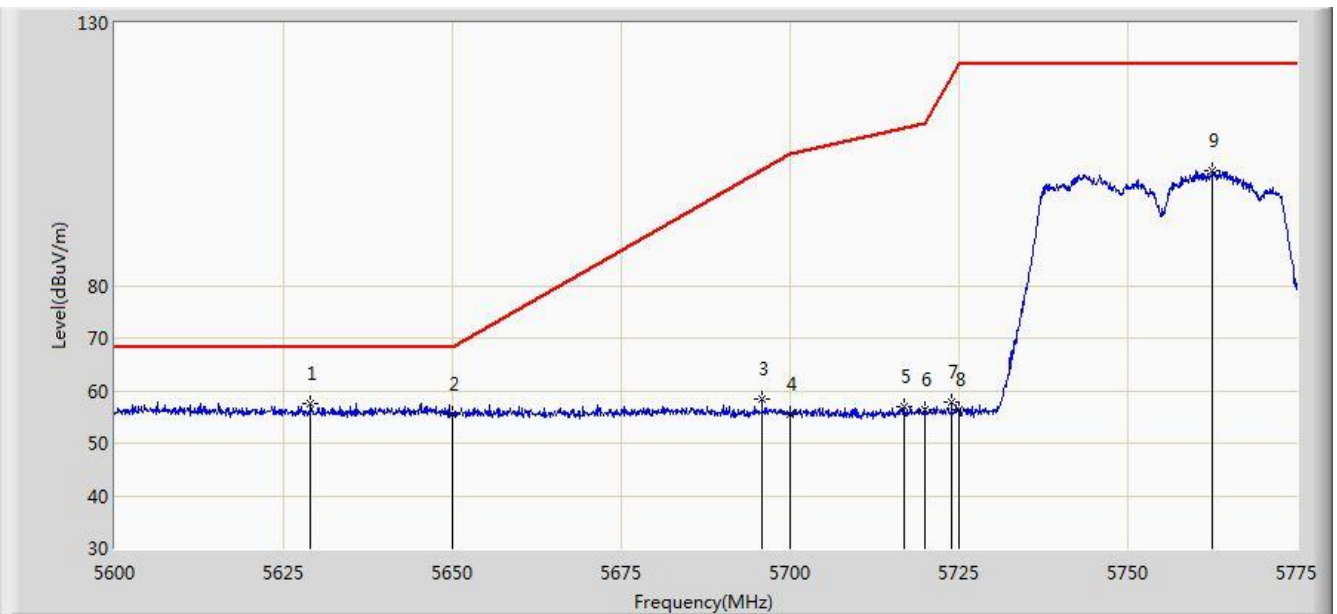

No	Flag	Mark	Frequency (MHz)	Measure Level (dBuV/m)	Reading Level (dBuV)	Over Limit (dB)	Limit (dBuV/m)	Factor (dB)	Type
1		*	5629.050	57.607	54.015	-10.593	68.200	3.593	PK
2			5650.000	55.633	51.830	-12.567	68.200	3.803	PK
3			5695.812	58.452	54.469	-43.661	102.113	3.983	PK
4			5700.000	55.598	51.658	-49.602	105.200	3.940	PK
5			5716.812	56.949	53.045	-52.960	109.909	3.905	PK
6			5720.000	56.259	52.277	-54.541	110.800	3.982	PK
7			5723.900	57.865	53.787	-61.827	119.693	4.079	PK
8			5725.000	56.304	52.198	-65.896	122.200	4.105	PK
9			5762.487	101.793	97.350	N/A	N/A	4.443	PK

Note: Measure Level (dBuV/m) = Reading Level (dBuV) + Factor (dB)

Factor (dB) = Cable Loss (dB) + Antenna Factor (dB/m) - Pre\_Amplifier Gain (dB)

Site: AC2	Time: 2017/12/08 - 19:52
Limit: FCC_Part15.407_RE(3m)	Engineer: Snake Ni
Probe: BBHA9120D_1-18GHz	Polarity: Vertical
EUT: VR All-In-One Headset	Power: By Battery
Test Mode: Transmit by 802.11ac-VHT40 at Channel 5755MHz Ant 0 + 1	

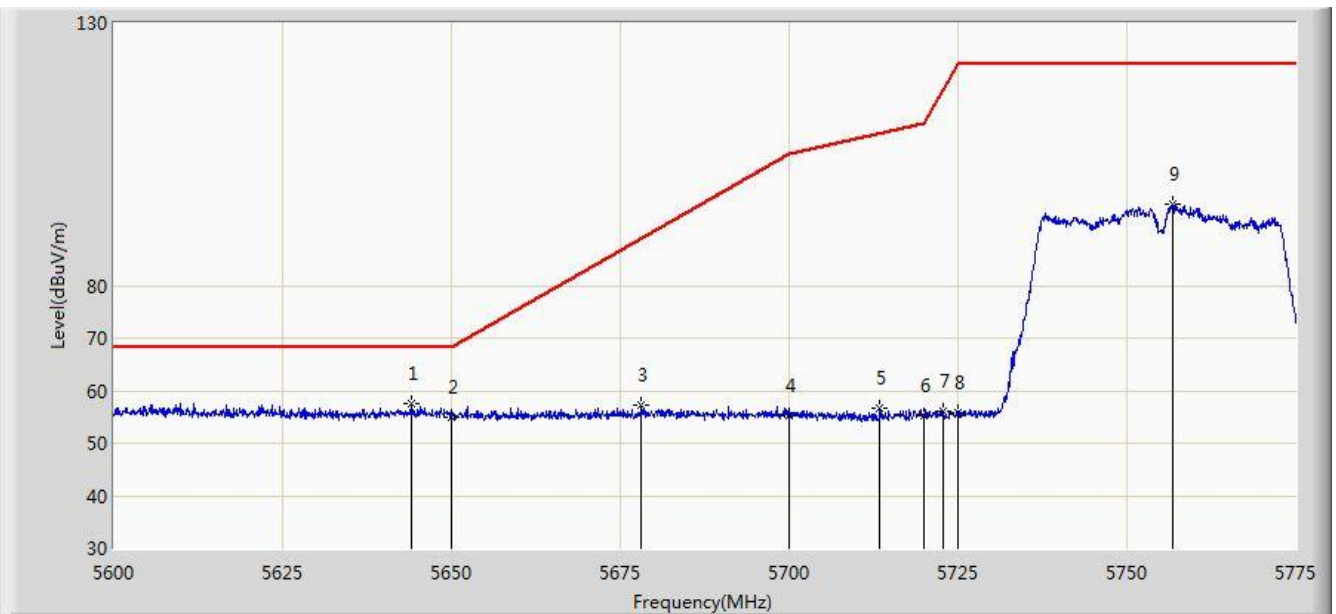

No	Flag	Mark	Frequency (MHz)	Measure Level (dBuV/m)	Reading Level (dBuV)	Over Limit (dB)	Limit (dBuV/m)	Factor (dB)	Type
1		*	5644.187	57.535	53.632	-10.665	68.200	3.903	PK
2			5650.000	55.014	51.211	-13.186	68.200	3.803	PK
3			5678.138	57.178	53.218	-31.884	89.062	3.960	PK
4			5700.000	55.306	51.366	-49.894	105.200	3.940	PK
5			5713.400	56.641	52.783	-52.313	108.954	3.858	PK
6			5720.000	55.137	51.155	-55.663	110.800	3.982	PK
7			5722.763	56.194	52.144	-60.906	117.101	4.050	PK
8			5725.000	55.665	51.559	-66.535	122.200	4.105	PK
9			5756.800	95.528	91.143	N/A	N/A	4.385	PK

Note: Measure Level (dBuV/m) = Reading Level (dBuV) + Factor (dB)

Factor (dB) = Cable Loss (dB) + Antenna Factor (dB/m) - Pre\_Amplifier Gain (dB)

Site: AC2	Time: 2017/12/08 - 19:54
Limit: FCC_Part15.407_RE(3m)	Engineer: Snake Ni
Probe: BBHA9120D_1-18GHz	Polarity: Horizontal
EUT: VR All-In-One Headset	Power: By Battery
Test Mode: Transmit by 802.11ac-VHT40 at Channel 5795MHz Ant 0 + 1	

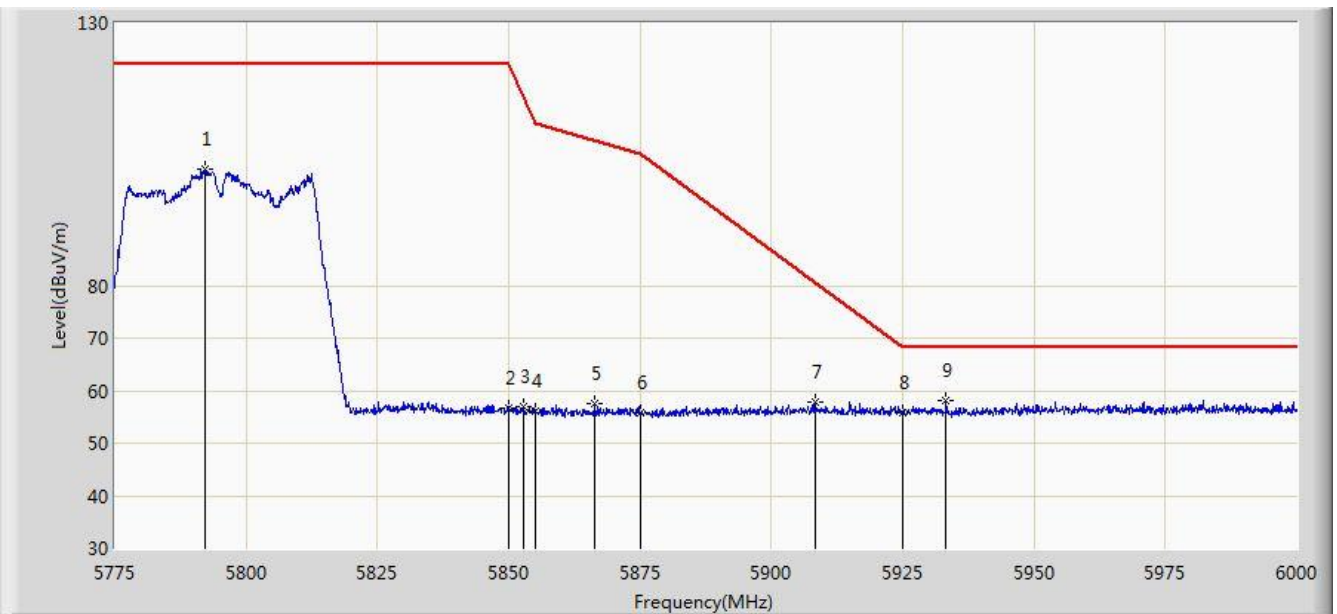

No	Flag	Mark	Frequency (MHz)	Measure Level (dBuV/m)	Reading Level (dBuV)	Over Limit (dB)	Limit (dBuV/m)	Factor (dB)	Type
1			5792.212	102.126	97.553	N/A	N/A	4.573	PK
2			5850.000	56.724	51.729	-65.476	122.200	4.995	PK
3			5852.737	56.953	51.962	-59.005	115.958	4.991	PK
4			5855.000	56.030	51.042	-54.770	110.800	4.987	PK
5			5866.462	57.558	52.581	-50.030	107.588	4.977	PK
6			5875.000	55.829	50.822	-49.371	105.200	5.008	PK
7			5908.312	57.720	52.532	-22.794	80.514	5.188	PK
8			5925.000	55.904	50.752	-12.296	68.200	5.152	PK
9		*	5933.288	58.106	52.918	-10.094	68.200	5.189	PK

Note: Measure Level (dBuV/m) = Reading Level (dBuV) + Factor (dB)

Factor (dB) = Cable Loss (dB) + Antenna Factor (dB/m) - Pre\_Amplifier Gain (dB)

Site: AC2	Time: 2017/12/08 - 19:56
Limit: FCC_Part15.407_RE(3m)	Engineer: Snake Ni
Probe: BBHA9120D_1-18GHz	Polarity: Vertical
EUT: VR All-In-One Headset	Power: By Battery
Test Mode: Transmit by 802.11ac-VHT40 at Channel 5795MHz Ant 0 + 1	

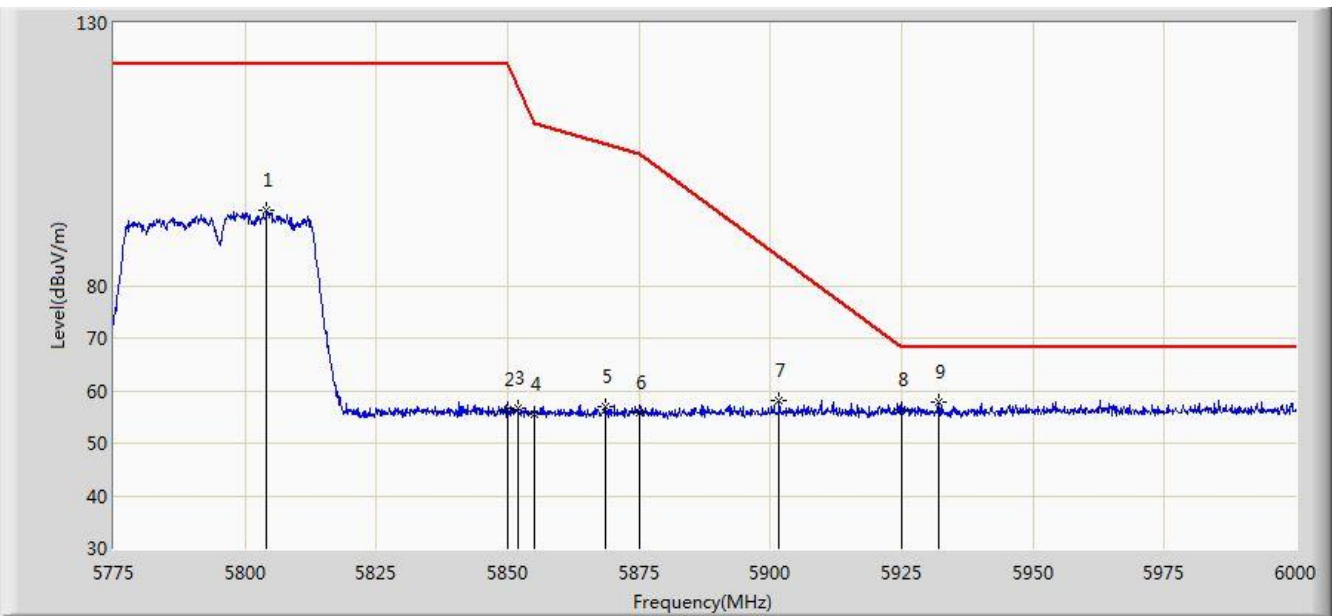

No	Flag	Mark	Frequency (MHz)	Measure Level (dBuV/m)	Reading Level (dBuV)	Over Limit (dB)	Limit (dBuV/m)	Factor (dB)	Type
1			5804.138	94.335	89.672	N/A	N/A	4.664	PK
2			5850.000	56.479	51.484	-65.721	122.200	4.995	PK
3			5852.062	56.557	51.565	-60.940	117.497	4.992	PK
4			5855.000	55.626	50.638	-55.174	110.800	4.987	PK
5			5868.487	57.088	52.110	-49.934	107.022	4.978	PK
6			5875.000	55.670	50.663	-49.530	105.200	5.008	PK
7			5901.675	58.234	53.075	-27.188	85.421	5.159	PK
8			5925.000	56.459	51.307	-11.741	68.200	5.152	PK
9		*	5932.163	57.797	52.606	-10.403	68.200	5.191	PK

Note: Measure Level (dBuV/m) = Reading Level (dBuV) + Factor (dB)

Factor (dB) = Cable Loss (dB) + Antenna Factor (dB/m) - Pre\_Amplifier Gain (dB)

Site: AC2	Time: 2017/12/08 - 19:59
Limit: FCC_Part15.209_RE(3m)	Engineer: Snake Ni
Probe: BBHA9120D_1-18GHz	Polarity: Horizontal
EUT: VR All-In-One Headset	Power: By Battery
Test Mode: Transmit by 802.11ac-VHT80 at Channel 5210MHz Ant 0 + 1	

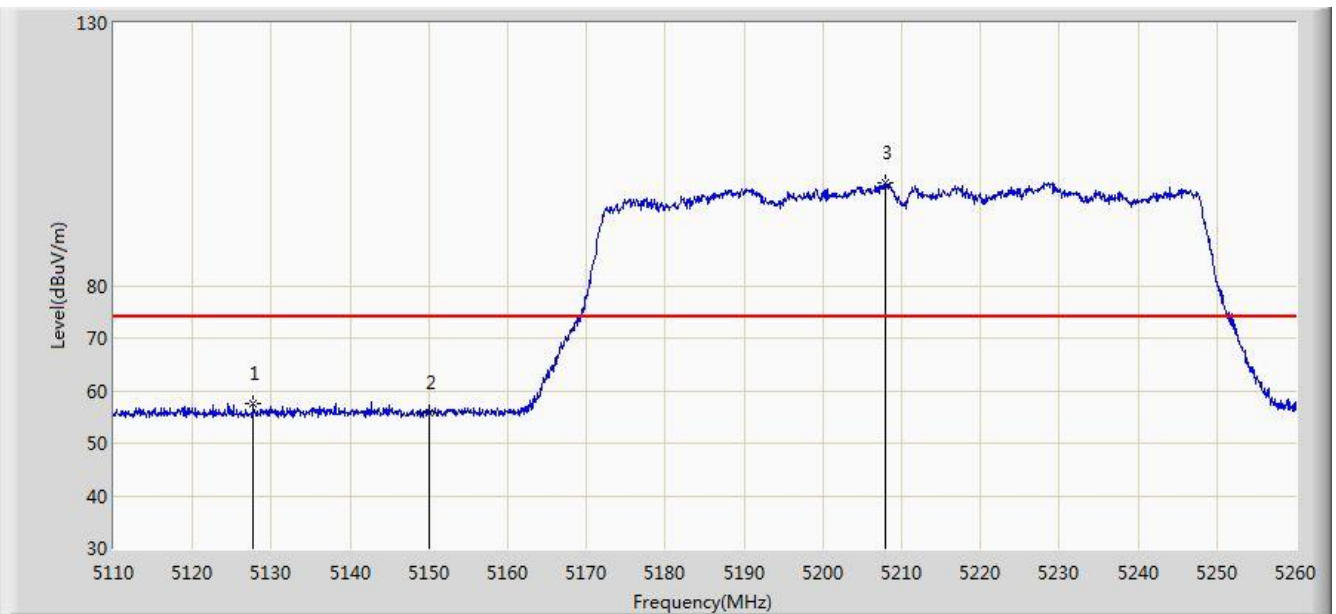

No	Flag	Mark	Frequency (MHz)	Measure Level (dBuV/m)	Reading Level (dBuV)	Over Limit (dB)	Limit (dBuV/m)	Factor (dB)	Type
1			5127.700	57.552	54.390	-16.448	74.000	3.161	PK
2			5150.000	55.849	52.779	-18.151	74.000	3.069	PK
3		*	5207.875	99.615	96.823	N/A	N/A	2.792	PK

Note: Measure Level (dBμV/m) = Reading Level (dBμV) + Factor (dB)

Factor (dB) = Cable Loss (dB) + Antenna Factor (dB/m) - Pre\_Amplifier Gain (dB)

Site: AC2	Time: 2017/12/08 - 20:04
Limit: FCC_Part15.209_RE(3m)	Engineer: Snake Ni
Probe: BBHA9120D_1-18GHz	Polarity: Horizontal
EUT: VR All-In-One Headset	Power: By Battery
Test Mode: Transmit by 802.11ac-VHT80 at Channel 5210MHz Ant 0 + 1	

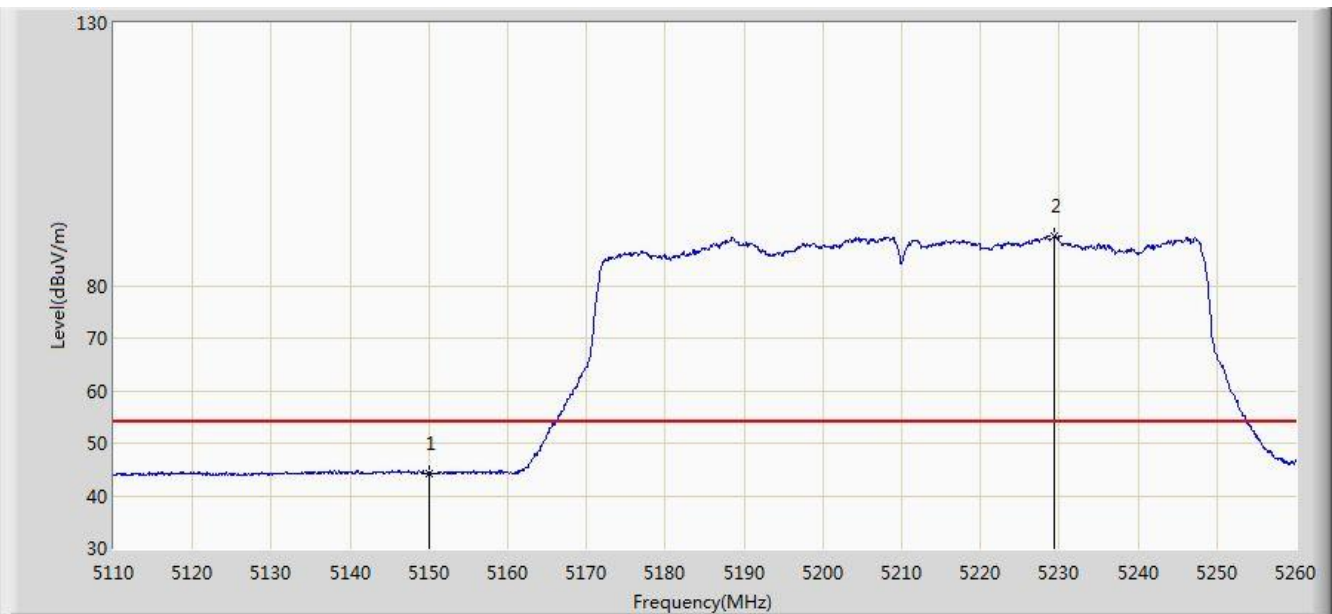

No	Flag	Mark	Frequency (MHz)	Measure Level (dBuV/m)	Reading Level (dBuV)	Over Limit (dB)	Limit (dBuV/m)	Factor (dB)	Type
1			5150.000	44.243	41.173	-9.757	54.000	3.069	AV
2		*	5229.400	89.376	86.571	N/A	N/A	2.805	AV

Note: Measure Level (dBμV/m) = Reading Level (dBμV) + Factor (dB)

Factor (dB) = Cable Loss (dB) + Antenna Factor (dB/m) - Pre\_Amplifier Gain (dB)

Site: AC2	Time: 2017/12/08 - 20:06
Limit: FCC_Part15.209_RE(3m)	Engineer: Snake Ni
Probe: BBHA9120D_1-18GHz	Polarity: Vertical
EUT: VR All-In-One Headset	Power: By Battery
Test Mode: Transmit by 802.11ac-VHT80 at Channel 5210MHz Ant 0 + 1	

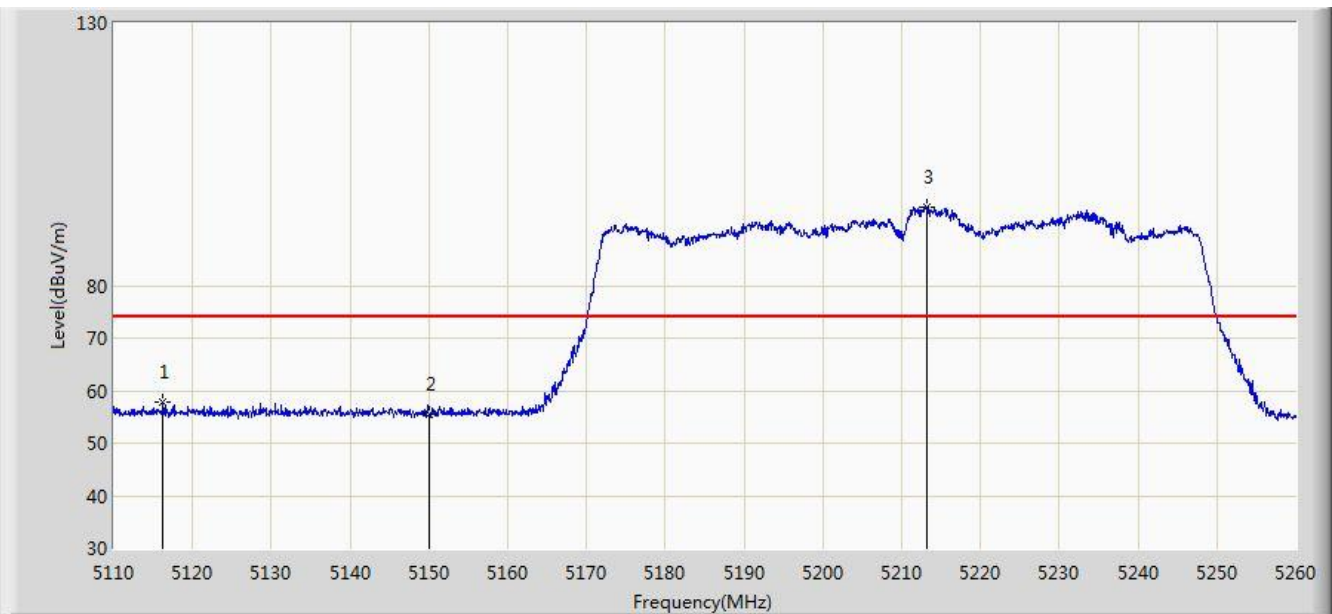

No	Flag	Mark	Frequency (MHz)	Measure Level (dBuV/m)	Reading Level (dBuV)	Over Limit (dB)	Limit (dBuV/m)	Factor (dB)	Type
1			5116.225	57.705	54.540	-16.295	74.000	3.164	PK
2			5150.000	55.548	52.478	-18.452	74.000	3.069	PK
3		*	5213.200	94.982	92.183	N/A	N/A	2.799	PK

Note: Measure Level (dBμV/m) = Reading Level (dBμV) + Factor (dB)

Factor (dB) = Cable Loss (dB) + Antenna Factor (dB/m) - Pre\_Amplifier Gain (dB)

Site: AC2	Time: 2017/12/08 - 20:08
Limit: FCC_Part15.209_RE(3m)	Engineer: Snake Ni
Probe: BBHA9120D_1-18GHz	Polarity: Vertical
EUT: VR All-In-One Headset	Power: By Battery
Test Mode: Transmit by 802.11ac-VHT80 at Channel 5210MHz Ant 0 + 1	

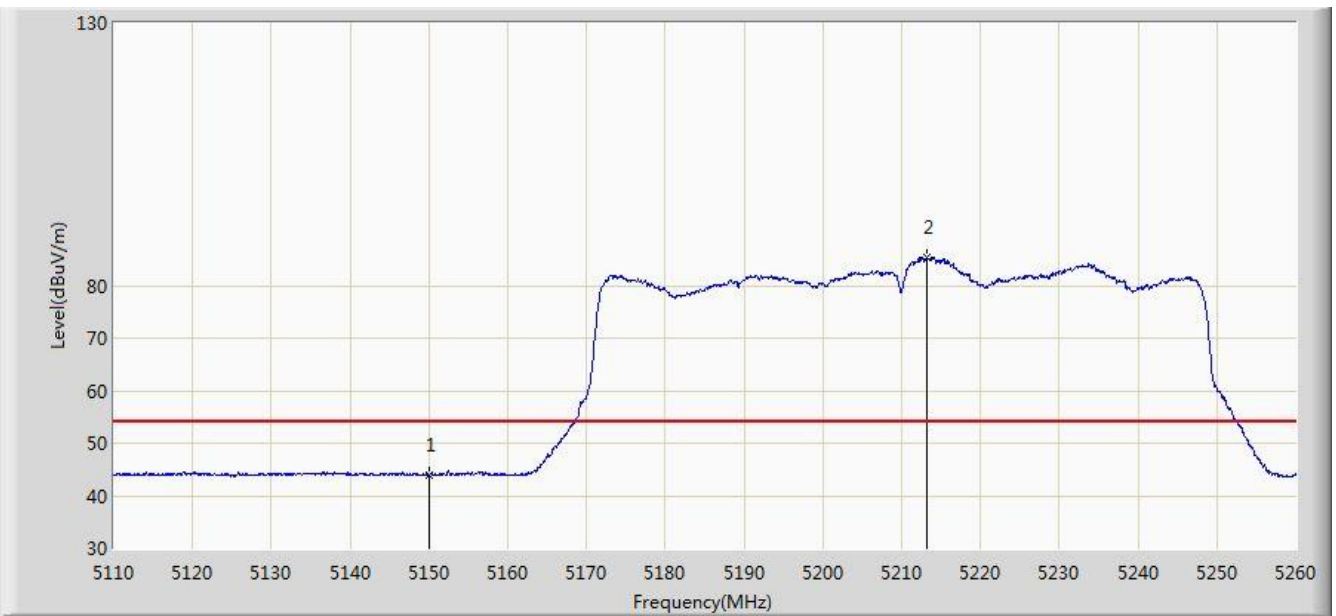

No	Flag	Mark	Frequency (MHz)	Measure Level (dBuV/m)	Reading Level (dBuV)	Over Limit (dB)	Limit (dBuV/m)	Factor (dB)	Type
1			5150.000	43.778	40.708	-10.222	54.000	3.069	AV
2		*	5213.275	85.225	82.425	N/A	N/A	2.800	AV

Note: Measure Level (dBμV/m) = Reading Level (dBμV) + Factor (dB)

Factor (dB) = Cable Loss (dB) + Antenna Factor (dB/m) - Pre\_Amplifier Gain (dB)



Site: AC2	Time: 2017/12/08 - 20:10
Limit: FCC_Part15.209_RE(3m)	Engineer: Snake Ni
Probe: BBHA9120D_1-18GHz	Polarity: Horizontal
EUT: VR All-In-One Headset	Power: By Battery
Test Mode: Transmit by 802.11ac-VHT80 at Channel 5290MHz Ant 0 + 1	

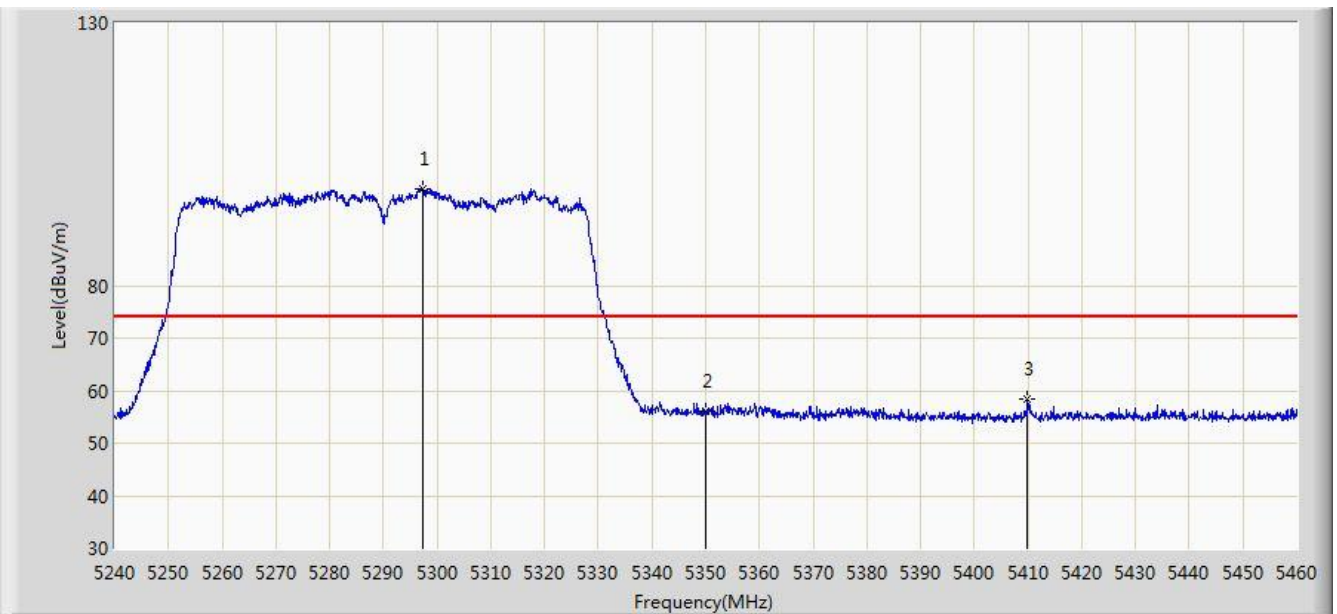

No	Flag	Mark	Frequency (MHz)	Measure Level (dBuV/m)	Reading Level (dBuV)	Over Limit (dB)	Limit (dBuV/m)	Factor (dB)	Type
1		*	5297.420	98.534	95.895	N/A	N/A	2.639	PK
2			5350.000	56.058	53.361	-17.942	74.000	2.697	PK
3			5409.950	58.290	55.165	-15.710	74.000	3.125	PK

Note: Measure Level (dB $\mu$ V/m) = Reading Level (dB $\mu$ V) + Factor (dB)

Factor (dB) = Cable Loss (dB) + Antenna Factor (dB/m) - Pre\_Amplifier Gain (dB)

Site: AC2	Time: 2017/12/08 - 20:11
Limit: FCC_Part15.209_RE(3m)	Engineer: Snake Ni
Probe: BBHA9120D_1-18GHz	Polarity: Horizontal
EUT: VR All-In-One Headset	Power: By Battery
Test Mode: Transmit by 802.11ac-VHT80 at Channel 5290MHz Ant 0 + 1	

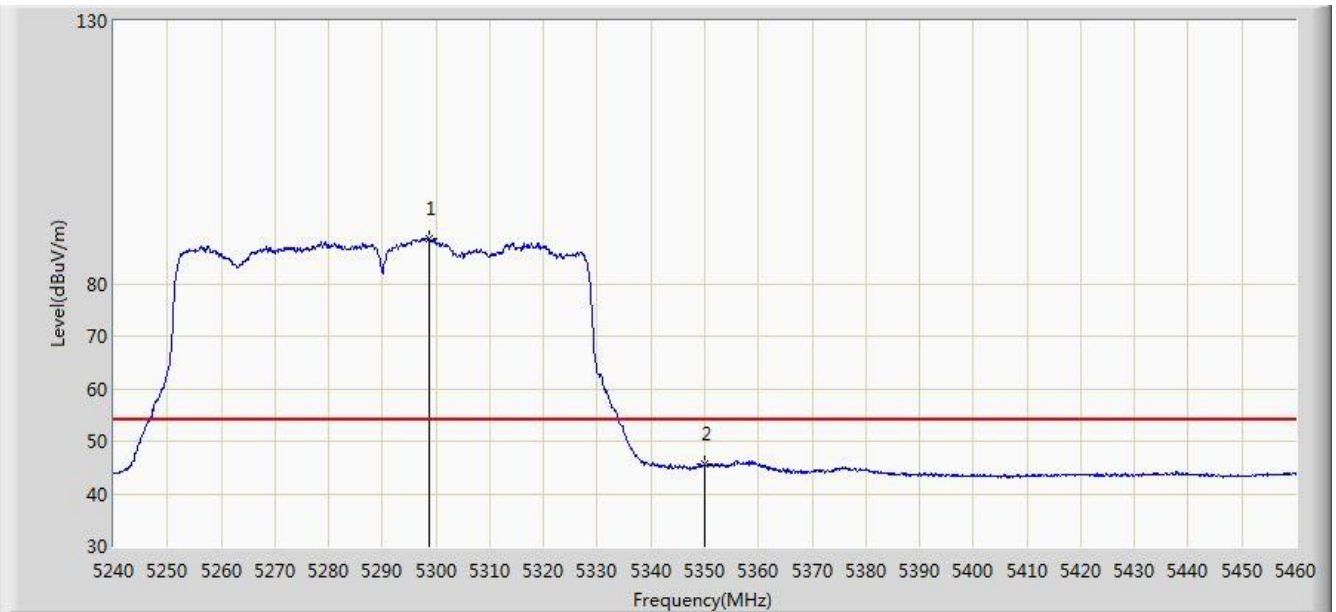

No	Flag	Mark	Frequency (MHz)	Measure Level (dBuV/m)	Reading Level (dBuV)	Over Limit (dB)	Limit (dBuV/m)	Factor (dB)	Type
1		*	5298.630	88.679	86.047	N/A	N/A	2.632	AV
2			5350.000	45.641	42.944	-8.359	54.000	2.697	AV

Note: Measure Level (dBμV/m) = Reading Level (dBμV) + Factor (dB)

Factor (dB) = Cable Loss (dB) + Antenna Factor (dB/m) - Pre\_Amplifier Gain (dB)

Site: AC2	Time: 2017/12/08 - 20:14
Limit: FCC_Part15.209_RE(3m)	Engineer: Snake Ni
Probe: BBHA9120D_1-18GHz	Polarity: Vertical
EUT: VR All-In-One Headset	Power: By Battery
Test Mode: Transmit by 802.11ac-VHT80 at Channel 5290MHz Ant 0 + 1	

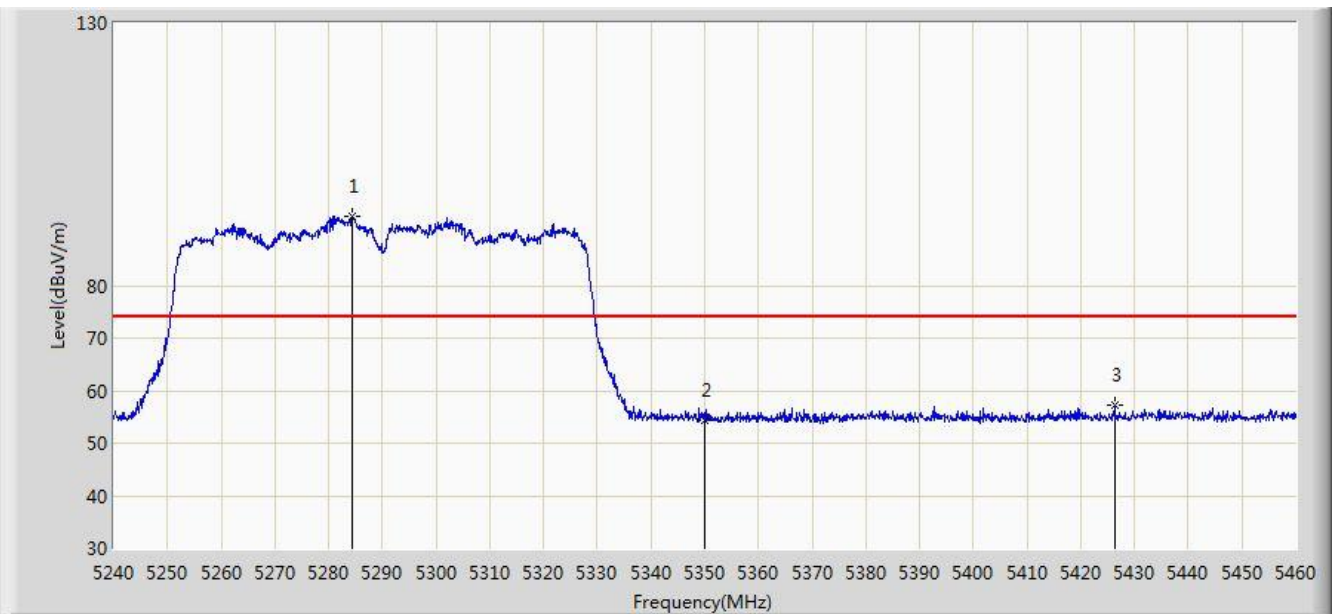

No	Flag	Mark	Frequency (MHz)	Measure Level (dBuV/m)	Reading Level (dBuV)	Over Limit (dB)	Limit (dBuV/m)	Factor (dB)	Type
1		*	5284.440	93.201	90.511	N/A	N/A	2.690	PK
2			5350.000	54.458	51.761	-19.542	74.000	2.697	PK
3			5426.230	57.312	54.002	-16.688	74.000	3.310	PK

Note: Measure Level (dBμV/m) = Reading Level (dBμV) + Factor (dB)

Factor (dB) = Cable Loss (dB) + Antenna Factor (dB/m) - Pre\_Amplifier Gain (dB)

Site: AC2	Time: 2017/12/08 - 20:15
Limit: FCC_Part15.209_RE(3m)	Engineer: Snake Ni
Probe: BBHA9120D_1-18GHz	Polarity: Vertical
EUT: VR All-In-One Headset	Power: By Battery
Test Mode: Transmit by 802.11ac-VHT80 at Channel 5290MHz Ant 0 + 1	

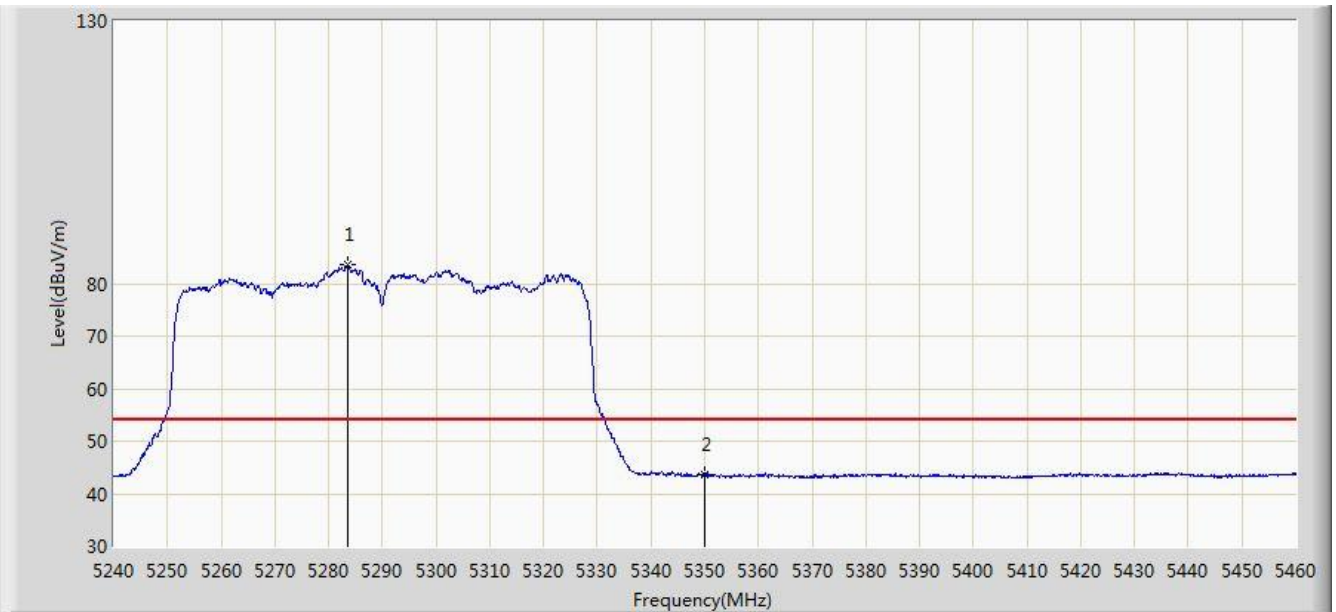

No	Flag	Mark	Frequency (MHz)	Measure Level (dBuV/m)	Reading Level (dBuV)	Over Limit (dB)	Limit (dBuV/m)	Factor (dB)	Type
1		*	5283.670	83.513	80.822	N/A	N/A	2.691	AV
2			5350.000	43.737	41.040	-10.263	54.000	2.697	AV

Note: Measure Level (dBμV/m) = Reading Level (dBμV) + Factor (dB)

Factor (dB) = Cable Loss (dB) + Antenna Factor (dB/m) - Pre\_Amplifier Gain (dB)

Site: AC2	Time: 2017/12/08 - 20:17
Limit: FCC_Part15.209_RE(3m)	Engineer: Snake Ni
Probe: BBHA9120D_1-18GHz	Polarity: Horizontal
EUT: VR All-In-One Headset	Power: By Battery
Test Mode: Transmit by 802.11ac-VHT80 at Channel 5530MHz Ant 0 + 1	

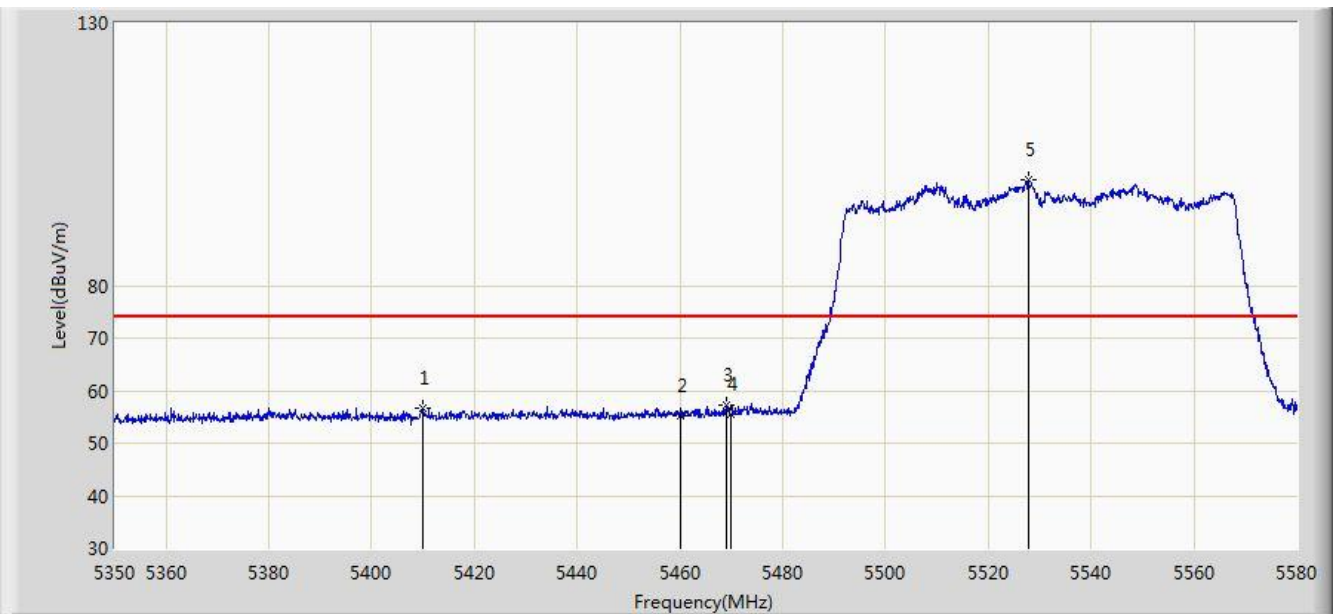

No	Flag	Mark	Frequency (MHz)	Measure Level (dBuV/m)	Reading Level (dBuV)	Over Limit (dB)	Limit (dBuV/m)	Factor (dB)	Type
1			5410.030	56.771	53.644	-17.229	74.000	3.127	PK
2			5460.000	55.172	51.979	-18.828	74.000	3.194	PK
3			5468.910	57.226	53.734	-16.774	74.000	3.493	PK
4			5470.000	55.569	52.040	-18.431	74.000	3.529	PK
5		*	5527.790	100.091	96.655	N/A	N/A	3.436	PK

Note: Measure Level (dB $\mu$ V/m) = Reading Level (dB $\mu$ V) + Factor (dB)

Factor (dB) = Cable Loss (dB) + Antenna Factor (dB/m) - Pre\_Amplifier Gain (dB)

Site: AC2	Time: 2017/12/08 - 20:19
Limit: FCC_Part15.209_RE(3m)	Engineer: Snake Ni
Probe: BBHA9120D_1-18GHz	Polarity: Horizontal
EUT: VR All-In-One Headset	Power: By Battery
Test Mode: Transmit by 802.11ac-VHT80 at Channel 5530MHz Ant 0 + 1	

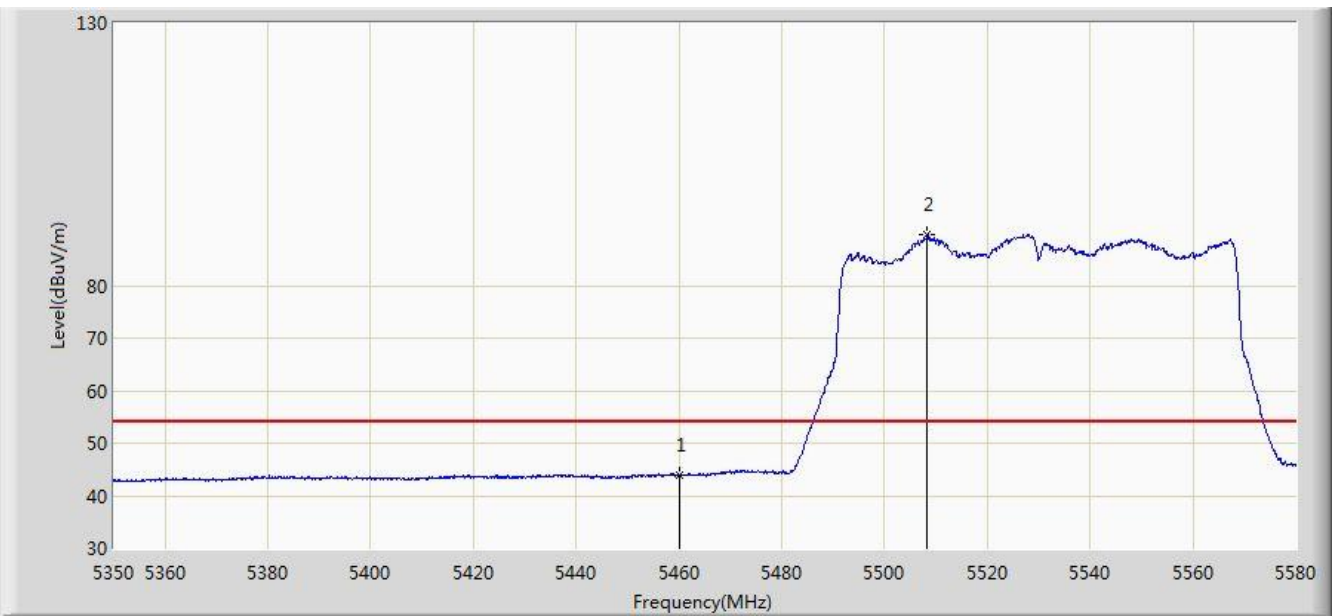

No	Flag	Mark	Frequency (MHz)	Measure Level (dBuV/m)	Reading Level (dBuV)	Over Limit (dB)	Limit (dBuV/m)	Factor (dB)	Type
1			5460.000	43.991	40.798	-10.009	54.000	3.194	AV
2		*	5508.355	89.712	86.565	N/A	N/A	3.147	AV

Note: Measure Level (dBμV/m) = Reading Level (dBμV) + Factor (dB)

Factor (dB) = Cable Loss (dB) + Antenna Factor (dB/m) - Pre\_Amplifier Gain (dB)

Site: AC2	Time: 2017/12/08 - 20:20
Limit: FCC_Part15.209_RE(3m)	Engineer: Snake Ni
Probe: BBHA9120D_1-18GHz	Polarity: Vertical
EUT: VR All-In-One Headset	Power: By Battery
Test Mode: Transmit by 802.11ac-VHT80 at Channel 5530MHz Ant 0 + 1	

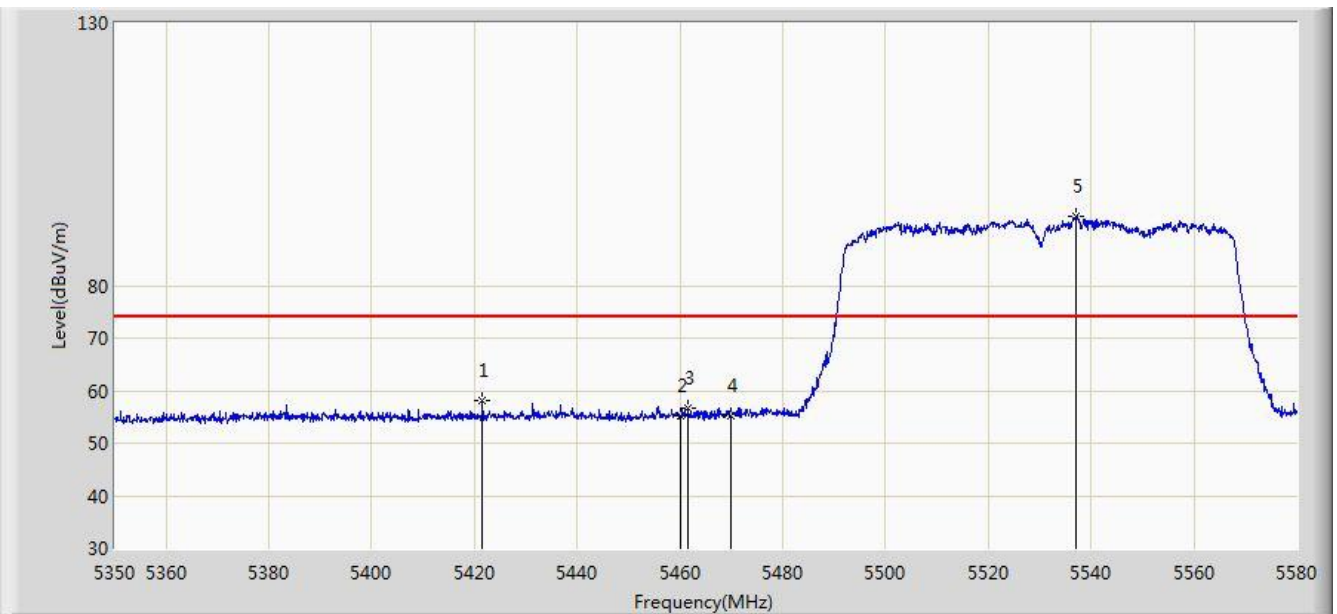

No	Flag	Mark	Frequency (MHz)	Measure Level (dBuV/m)	Reading Level (dBuV)	Over Limit (dB)	Limit (dBuV/m)	Factor (dB)	Type
1			5421.530	58.248	54.956	-15.752	74.000	3.292	PK
2			5460.000	55.223	52.030	-18.777	74.000	3.194	PK
3			5461.665	56.768	53.519	-17.232	74.000	3.249	PK
4			5470.000	55.326	51.797	-18.674	74.000	3.529	PK
5		*	5536.990	93.247	89.898	N/A	N/A	3.349	PK

Note: Measure Level (dBμV/m) = Reading Level (dBμV) + Factor (dB)

Factor (dB) = Cable Loss (dB) + Antenna Factor (dB/m) - Pre\_Amplifier Gain (dB)

Site: AC2	Time: 2017/12/08 - 20:22
Limit: FCC_Part15.209_RE(3m)	Engineer: Snake Ni
Probe: BBHA9120D_1-18GHz	Polarity: Vertical
EUT: VR All-In-One Headset	Power: By Battery
Test Mode: Transmit by 802.11ac-VHT80 at Channel 5530MHz Ant 0 + 1	

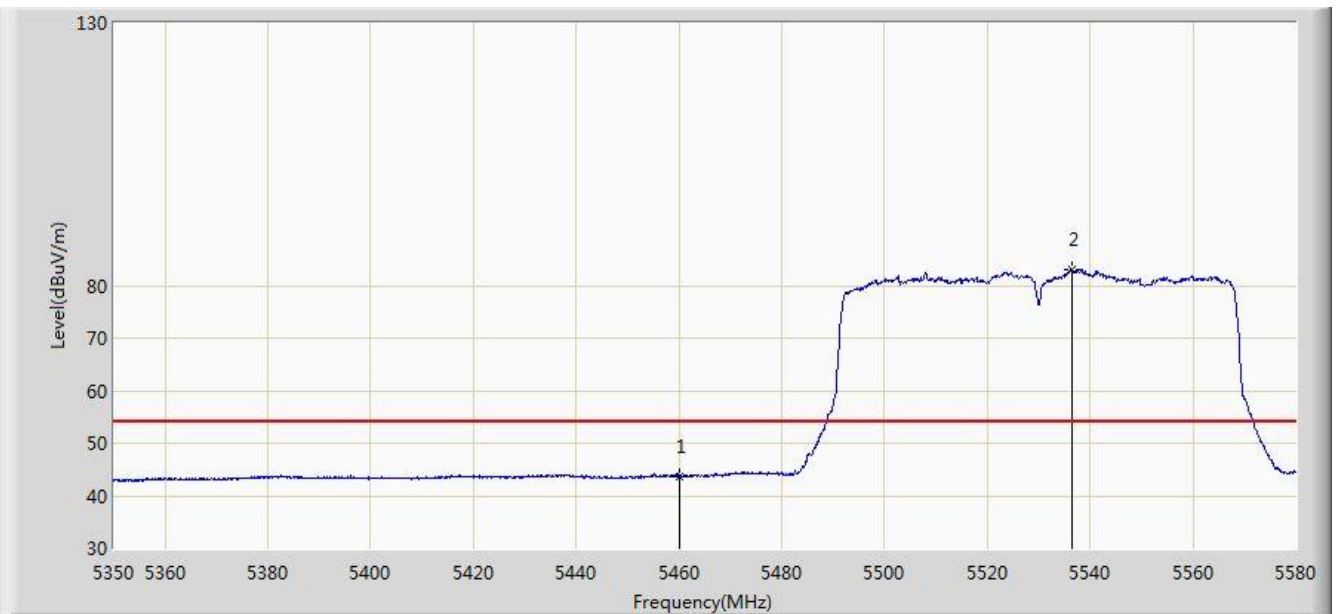

No	Flag	Mark	Frequency (MHz)	Measure Level (dBuV/m)	Reading Level (dBuV)	Over Limit (dB)	Limit (dBuV/m)	Factor (dB)	Type
1			5460.000	43.724	40.531	-10.276	54.000	3.194	AV
2		*	5536.530	83.169	79.816	N/A	N/A	3.354	AV

Note: Measure Level (dB $\mu$ V/m) = Reading Level (dB $\mu$ V) + Factor (dB)

Factor (dB) = Cable Loss (dB) + Antenna Factor (dB/m) - Pre\_Amplifier Gain (dB)



Site: AC2	Time: 2017/12/08 - 20:27
Limit: FCC_Part15.407_RE(3m)	Engineer: Snake Ni
Probe: BBHA9120D_1-18GHz	Polarity: Horizontal
EUT: VR All-In-One Headset	Power: By Battery
Test Mode: Transmit by 802.11ac-VHT80 at Channel 5775MHz Ant 0 + 1	

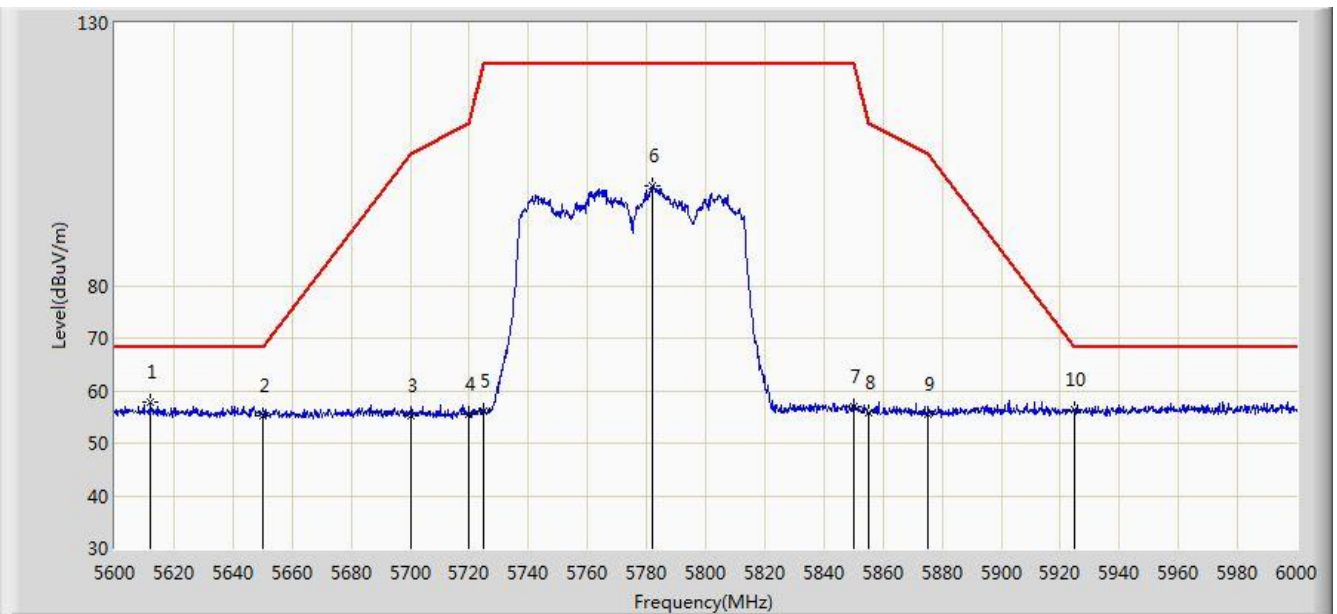

No	Flag	Mark	Frequency (MHz)	Measure Level (dBuV/m)	Reading Level (dBuV)	Over Limit (dB)	Limit (dBuV/m)	Factor (dB)	Type
1		*	5612.200	57.821	54.125	-10.379	68.200	3.696	PK
2			5650.000	55.314	51.511	-12.886	68.200	3.803	PK
3			5700.000	55.204	51.264	-49.996	105.200	3.940	PK
4			5720.000	55.484	51.502	-55.316	110.800	3.982	PK
5			5725.000	56.168	52.062	-66.032	122.200	4.105	PK
6			5782.000	99.006	94.564	N/A	N/A	4.442	PK
7			5850.000	56.838	51.843	-65.362	122.200	4.995	PK
8			5855.000	55.861	50.873	-54.939	110.800	4.987	PK
9			5875.000	55.511	50.504	-49.689	105.200	5.008	PK
10			5925.000	56.469	51.317	-11.731	68.200	5.152	PK

Note: Measure Level (dB $\mu$ V/m) = Reading Level (dB $\mu$ V) + Factor (dB)

Factor (dB) = Cable Loss (dB) + Antenna Factor (dB/m) - Pre\_Amplifier Gain (dB)

Site: AC2	Time: 2017/12/08 - 20:31
Limit: FCC_Part15.407_RE(3m)	Engineer: Snake Ni
Probe: BBHA9120D_1-18GHz	Polarity: Vertical
EUT: VR All-In-One Headset	Power: By Battery
Test Mode: Transmit by 802.11ac-VHT80 at Channel 5775MHz Ant 0 + 1	

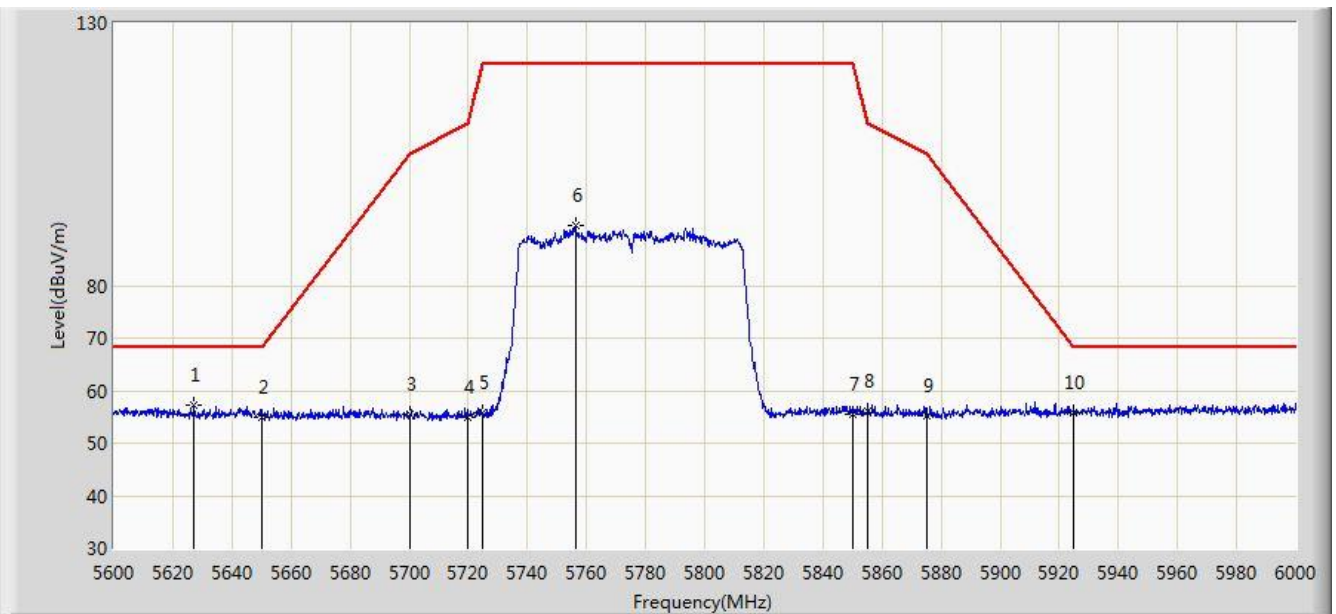

No	Flag	Mark	Frequency (MHz)	Measure Level (dBuV/m)	Reading Level (dBuV)	Over Limit (dB)	Limit (dBuV/m)	Factor (dB)	Type
1		*	5627.200	57.180	53.619	-11.020	68.200	3.561	PK
2			5650.000	54.927	51.124	-13.273	68.200	3.803	PK
3			5700.000	55.380	51.440	-49.820	105.200	3.940	PK
4			5720.000	55.032	51.050	-55.768	110.800	3.982	PK
5			5725.000	55.779	51.673	-66.421	122.200	4.105	PK
6			5756.400	91.419	87.041	N/A	N/A	4.378	PK
7			5850.000	55.635	50.640	-66.565	122.200	4.995	PK
8			5855.000	56.076	51.088	-54.724	110.800	4.987	PK
9			5875.000	55.122	50.115	-50.078	105.200	5.008	PK
10			5925.000	55.839	50.687	-12.361	68.200	5.152	PK

Note: Measure Level (dBuV/m) = Reading Level (dBuV) + Factor (dB)

Factor (dB) = Cable Loss (dB) + Antenna Factor (dB/m) - Pre\_Amplifier Gain (dB)

## 7.9. AC Conducted Emissions Measurement

### 7.9.1. Test Limit

FCC Part 15 Subpart C Paragraph 15.207 Limits		
Frequency (MHz)	QP (dBuV)	AV (dBuV)
0.15 - 0.50	66 - 56	56 - 46
0.50 - 5.0	56	46
5.0 - 30	60	50

Note 1: The lower limit shall apply at the transition frequencies.

Note 2: The limit decreases linearly with the logarithm of the frequency in the range 0.15MHz to 0.5MHz.

### 7.9.2. Test Setup

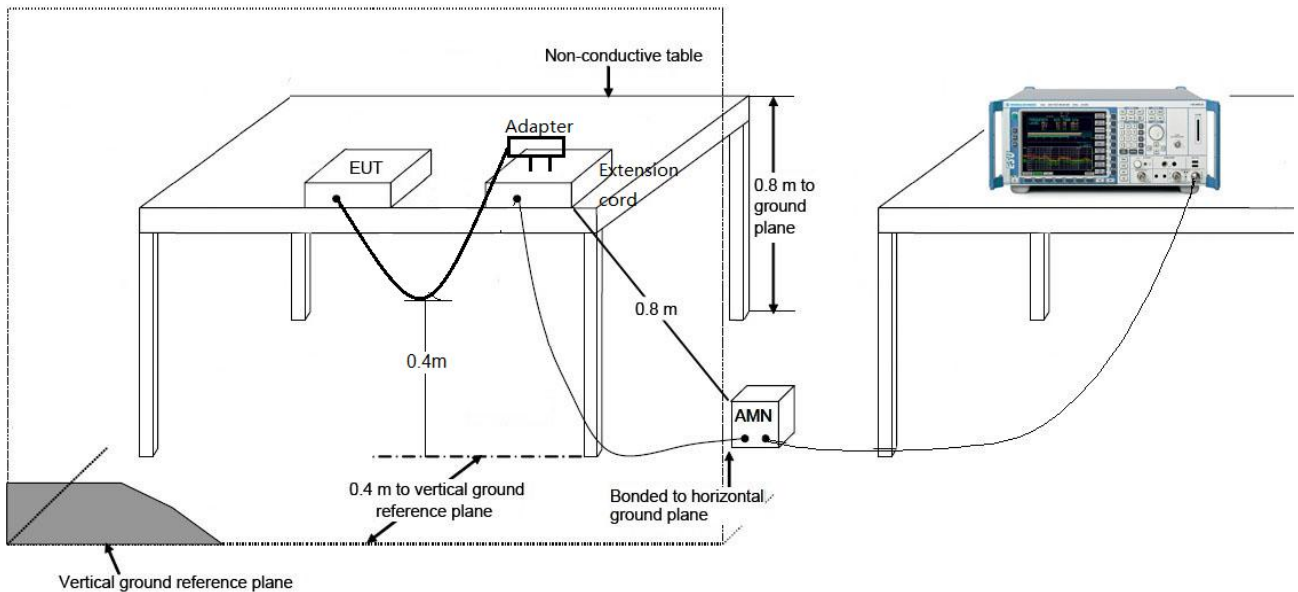

**7.9.3. Test Result**

Site: SR2	Time: 2017/12/11 - 09:42
Limit: FCC_Part15.207_CE_AC Power	Engineer: Polly Zong
Probe: ENV216_101683_Filter On	Polarity: Line
EUT: VR All-In-One Headset	Power: AC 120V/60Hz
Test Mode 1	

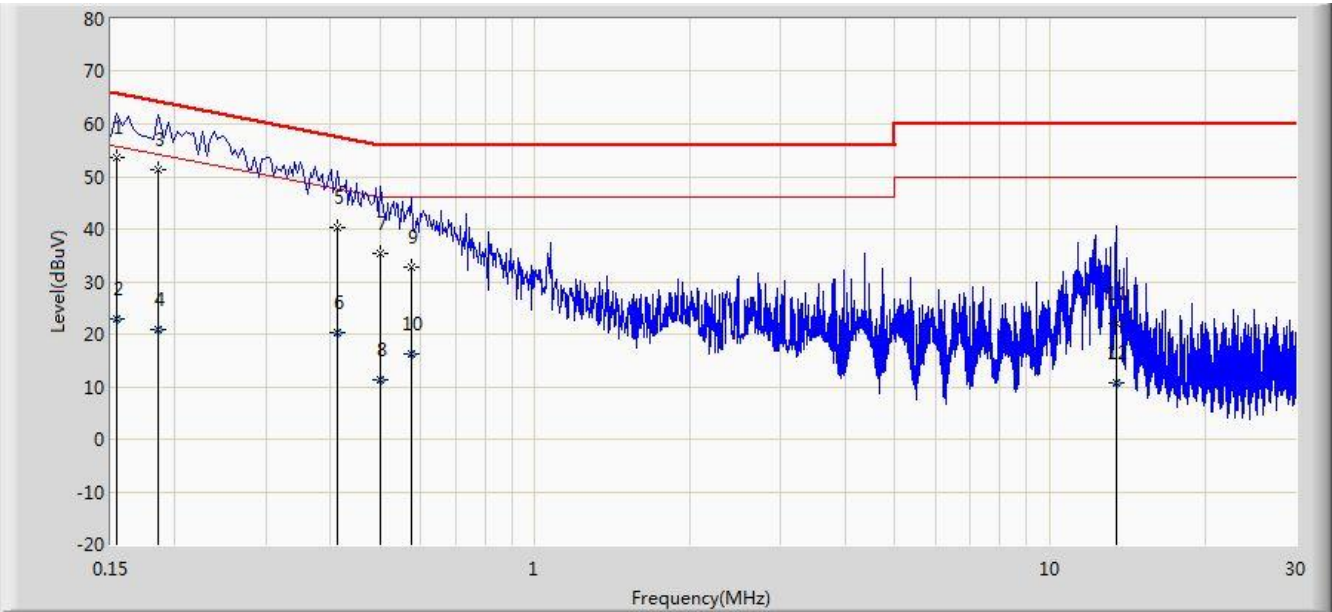

No	Flag	Mark	Frequency (MHz)	Measure Level (DBUV)	Reading Level (DBUV)	Over Limit (dB)	Limit (DBUV)	Factor (dB)	Type
1		*	0.154	53.703	42.963	-12.079	65.781	10.740	QP
2			0.154	22.917	12.178	-32.864	55.781	10.740	AV
3			0.186	51.290	41.251	-12.923	64.213	10.039	QP
4			0.186	20.816	10.777	-33.398	54.213	10.039	AV
5			0.414	40.173	30.076	-17.395	57.568	10.097	QP
6			0.414	20.256	10.159	-27.312	47.568	10.097	AV
7			0.502	35.484	25.327	-20.516	56.000	10.157	QP
8			0.502	11.164	1.007	-34.836	46.000	10.157	AV
9			0.574	32.660	22.531	-23.340	56.000	10.128	QP
10			0.574	16.193	6.065	-29.807	46.000	10.128	AV
11			13.478	22.065	12.006	-37.935	60.000	10.058	QP
12			13.478	10.723	0.664	-39.277	50.000	10.058	AV

Note: Measure Level (dBμV) = Reading Level (dBμV) + Factor (dB)

Factor (dB) = Cable Loss (dB) + LISN Factor (dB)

Site: SR2	Time: 2017/12/11 - 09:47
Limit: FCC_Part15.207_CE_AC Power	Engineer: Polly Zong
Probe: ENV216_101683_Filter On	Polarity: Neutral
EUT: VR All-In-One Headset	Power: AC 120V/60Hz
Test Mode 1	

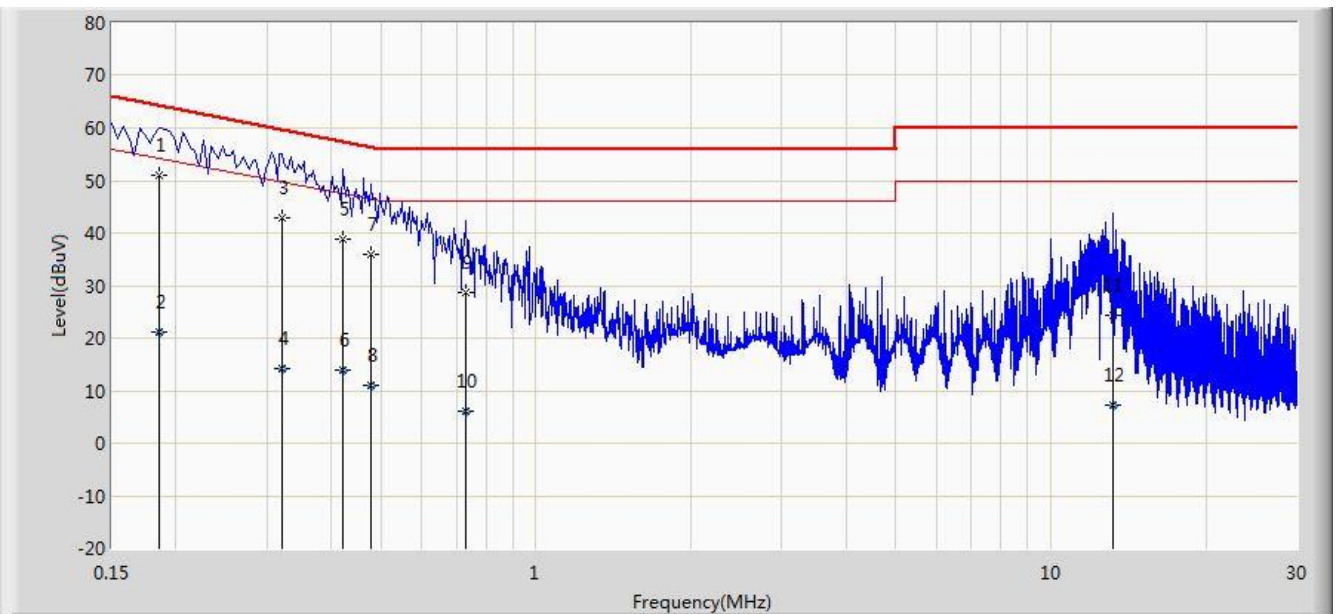

No	Flag	Mark	Frequency (MHz)	Measure Level (DBUV)	Reading Level (DBUV)	Over Limit (dB)	Limit (DBUV)	Factor (dB)	Type
1		*	0.186	51.156	41.121	-13.058	64.213	10.035	QP
2			0.186	21.022	10.987	-33.191	54.213	10.035	AV
3			0.322	42.988	32.934	-16.667	59.655	10.054	QP
4			0.322	14.165	4.111	-35.490	49.655	10.054	AV
5			0.422	38.901	28.772	-18.508	57.409	10.129	QP
6			0.422	13.852	3.723	-33.556	47.409	10.129	AV
7			0.478	36.045	25.874	-20.329	56.374	10.170	QP
8			0.478	10.930	0.759	-35.444	46.374	10.170	AV
9			0.730	28.618	18.561	-27.382	56.000	10.058	QP
10			0.730	6.187	-3.870	-39.813	46.000	10.058	AV
11			13.218	24.400	14.307	-35.600	60.000	10.093	QP
12			13.218	7.292	-2.802	-42.708	50.000	10.093	AV

Note: Measure Level (dB $\mu$ V) = Reading Level (dB $\mu$ V) + Factor (dB)

Factor (dB) = Cable Loss (dB) + LISN Factor (dB)

## 8. CONCLUSION

The data collected relate only the item(s) tested and show that the **VR All-In-One Headset** is in compliance with Part 15E of the FCC Rules.

————— The End —————