

iSenseTek Technology, Inc



Approval Sheet

Model : BLE module (nRF51xxx)

Part No : ISBLE1810-P51xxxxxA

ISBLE1506-A51xxxxxA

Datasheet Version : v2.1

Date : 2016/07/14

Approved	Checked	Designed

Customer name : _____

Model : _____

P/N : _____

Checked	Received

Index

1.	Overall Introduction.....	3
1.1	Applications	3
1.2	Features.....	4
2.	P/N Number Define.....	5
3.	Module Dimension	6
3.1	Product Dimensions.....	6
3.2	Pin Descriptions.....	7
3.3	PCB Layout Guide.....	12
4.	Main Chip Solution.....	13
5.	Shipment Packing Information	13
6.	Specification	14
6.1	Absolute Maximum Ratings	14
6.2	Operation Conditions	15
6.3	Electrical Specifications.....	15
6.3.1	Radio Transceiver	15
6.3.2	Transmitter Specifications	16
6.3.3	Receiver Specifications	17
6.3.4	Radio Timing Parameters.....	19
6.3.5	RSSI Specifications.....	19
6.3.6	CPU	19
6.3.7	Power Management.....	20
7.	Reference Circuit.....	21
7.1	Schematic with Internal LDO	21
7.2	Schematic with Internal DC/DC Converter.....	22
8.	Development Kit	23
9.	Antenna Forbidden Zone Description	25
10.	Statements	27
11.	Document History.....	28

1. Overall Introduction

iSenseTek's ISBLE is a Bluetooth smart (Bluetooth low energy or BLE) module designed based on Nordic solution. The feature of the module.

- Based on the Nordic nRF51822 SoC
- Multiple protocol of BLE & RF 2.4GHz & ANT+ upon customer preference
- Dimension:

Length	Width	Height	Part No
18 ± 0.3mm	10 ± 0.3mm	1.95 ± 0.2mm	ISBLE1810-P51xxxxxA
15 ± 0.3mm	6 ± 0.3mm	2 ± 0.2mm	ISBLE1506-A51xxxxxA

- Low power requirements, Ultra-low peak, Average and idle mode power Consumption
- Compatible with a large installed based of mobiles phones, tablets and computers
- Fully coverage of wireless applications
- BLE & RF transmission switching may help products to fit all operation system
- BLE & RF transmission switching may help products to fit all kinds of hardwares

1.1 Applications

Computer peripherals and I/O devices

- Mouse
- Keyboard
- Multi-touch trackpad

Interactive entertainment devices

- Remote control
- Gaming controller

Beacons

Personal area networks

- Health/fitness sensor and monitor devices
- Medical devices
- Key-fobs + Wrist watch
- Remote control toys

1.2 Features

2.4GHz transceiver

- -93 dBm sensitivity in Bluetooth® low energy mode
- 250 kbps, 1 Mbps, 2 Mbps supported data rates
- TX Power -20 to +4 dBm in 4 dB steps
- TX Power -30 dBm Whisper mode
- RSSI (1 dB resolution)

ARM® Cortex™-M0 32 bit processor

- Serial Wire Debug (SWD)

Memory

- 256 kB or 128 kB embedded flash program memory
- 16 kB or 32 kB RAM

Flexible Power Management

- Supply voltage range 1.8 V to 3.6 V
- 4.2 μ s wake-up using 16 MHz RCOSC
- 0.6 μ A at 3 V OFF mode
- 1.2 μ A at 3 V in OFF mode + 1 region RAM retention
- 2.6 μ A at 3 V ON mode, all blocks IDLE

S100 series Soft Device ready

On-air compatibility with nRF24L series

8/9/10 bit ADC - 8 configurable channels

32 General Purpose I/O Pins

One 32 bit and two 16 bit timers with counter mode

SPI Master/Slave

Low power comparator

Temperature sensor

Two-wire Master (I2C compatible)

UART (CTS/RTS)

CPU independent Programmable Peripheral Interconnect (PPI)

Quadrature Decoder (QDEC)

AES HW encryption

Real Timer Counter (RTC)

2. P/N Number Define

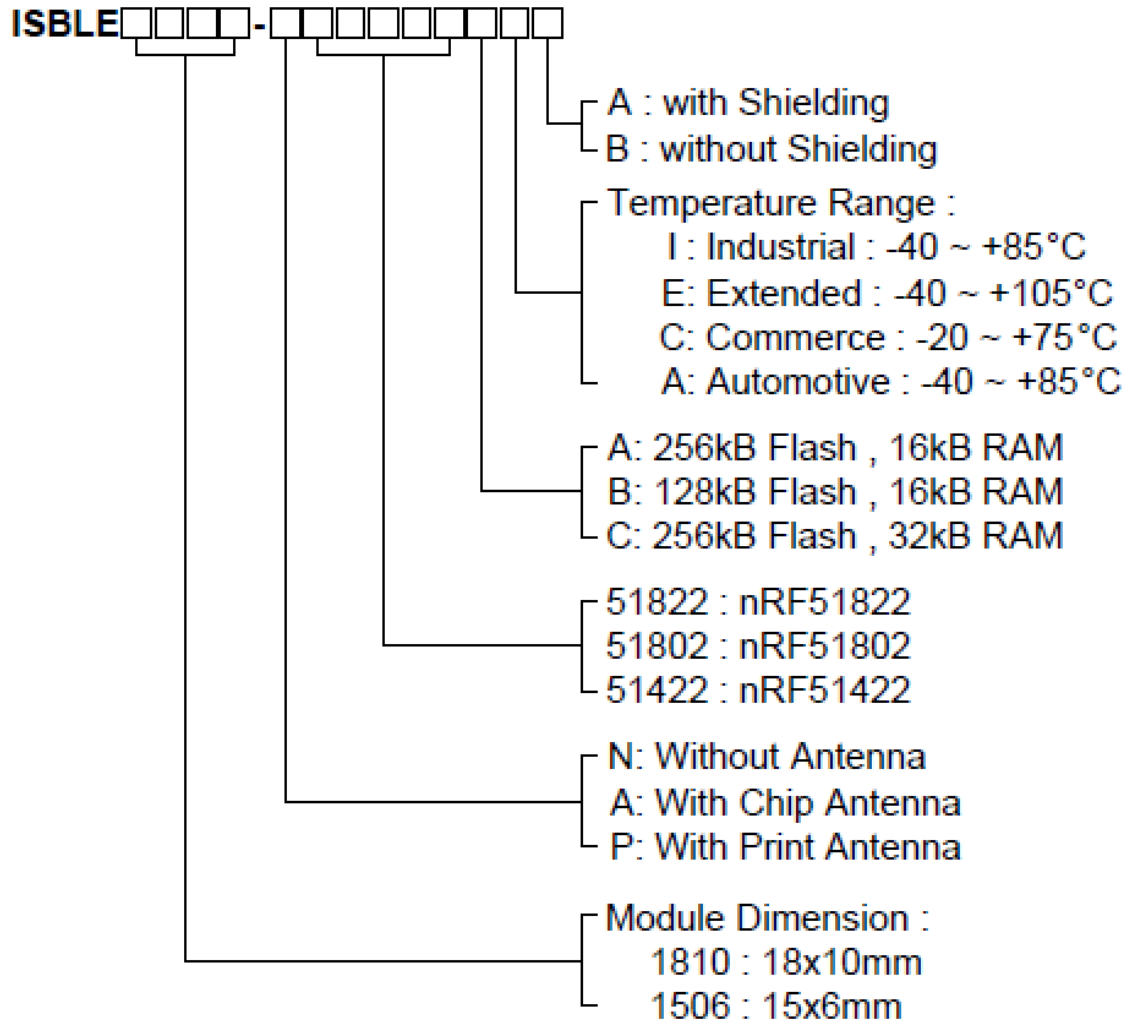

Figure 1 : P/N Number Define

3. Module Dimension

3.1 Product Dimensions

- ISBLE1810-P51xxxxxA

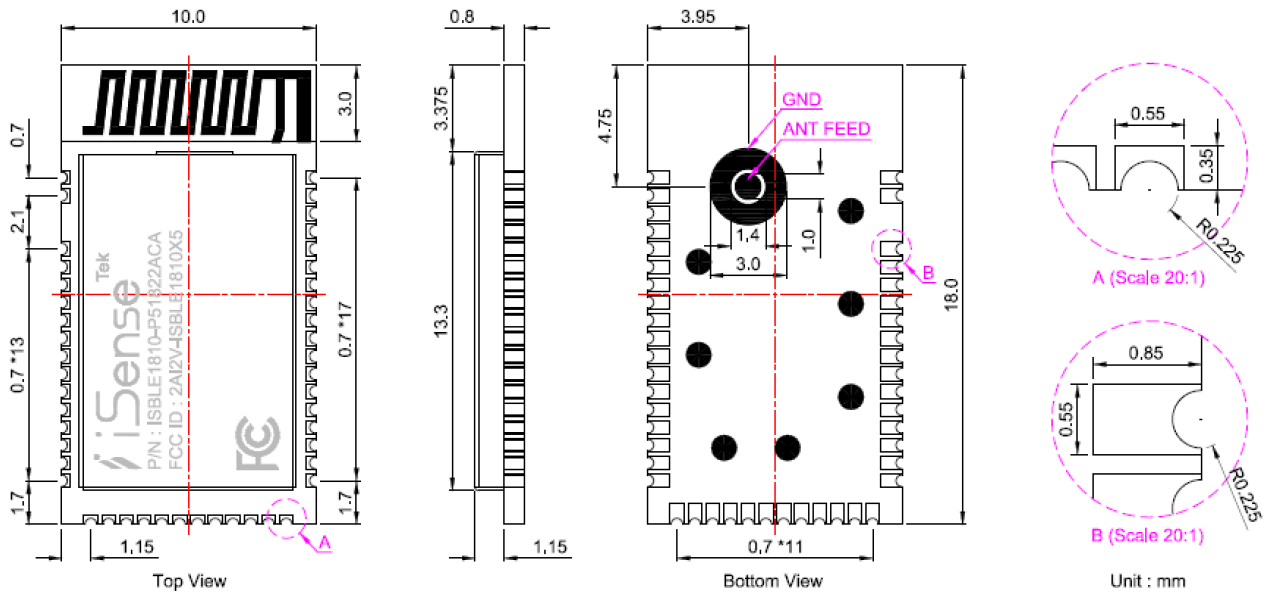

Figure 2 : Product Dimensions (ISBLE1810-P51xxxxxA)

- ISBLE1506-A51xxxxxA

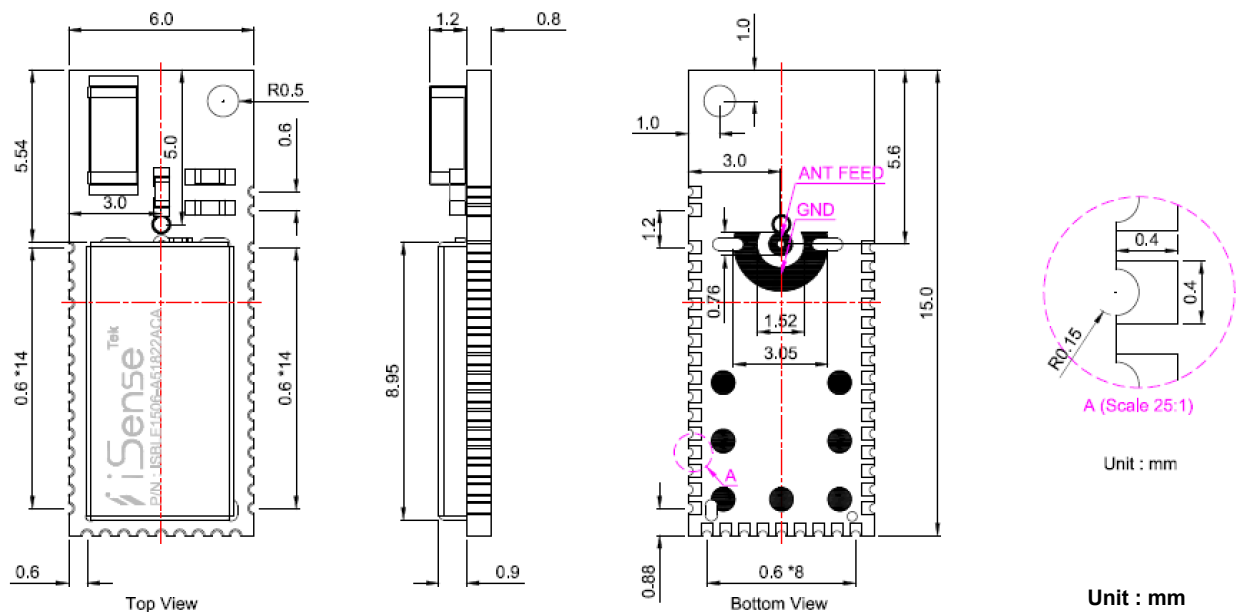

Figure 3 : Product Dimensions (ISBLE1506-A51xxxxxA)

3.2 Pin Descriptions

- ISBLE1810-P51xxxxA

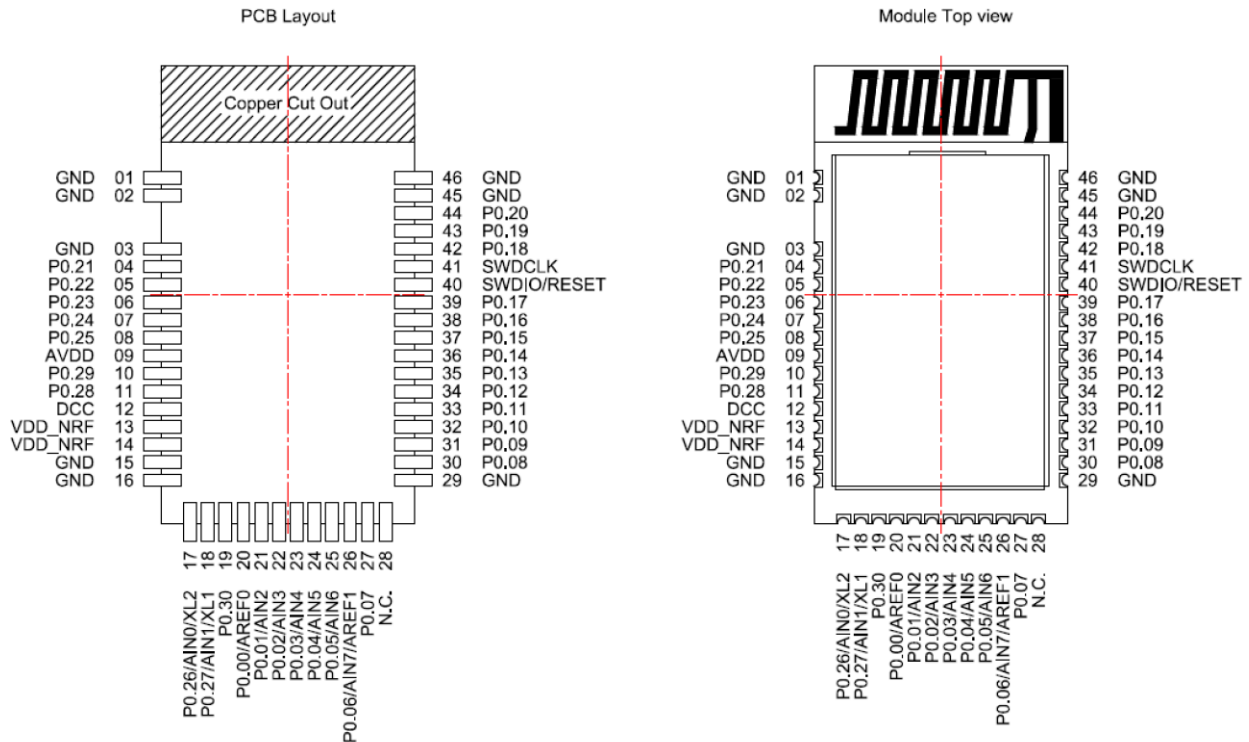

Figure 4 : Module Pin Descriptions (ISBLE1810-P51xxxxA)

Pin NO.	Name	Pin function	Description
1	GND	Ground	The pad must be connected to a solid ground plane
2	GND	Ground	The pad must be connected to a solid ground plane
3	GND	Ground	The pad must be connected to a solid ground plane
4	P0.21	Digital I/O	General-purpose digital I/O
5	P0.22	Digital I/O	General-purpose digital I/O
6	P0.23	Digital I/O	General-purpose digital I/O
7	P0.24	Digital I/O	General-purpose digital I/O
8	P0.25	Digital I/O	General-purpose digital I/O
9	AVDD	Power	Analog power supply
10	P0.29	Digital I/O	General-purpose digital I/O
11	P0.28	Digital I/O	General-purpose digital I/O
12	DCC	Power	DC/DC output voltage to external LC filter
13	VDD_NRF	Power	Power supply
14	VDD_NRF	Power	Power supply

Pin NO.	Name	Pin function	Description
15	GND	Ground	The pad must be connected to a solid ground plane
16	GND	Ground	The pad must be connected to a solid ground plane
17	P0.26	Digital I/O	General-purpose digital I/O
	AIN0	Analog input	ADC input 2
	XL2	Analog output	Connector for 32.768KHz crystal
	P0.27	Digital I/O	General-purpose digital I/O
18	AIN1	Analog input	ADC input 2
	XL1	Analog output	Connector for 32.768KHz crystal
19	P0.30	Digital I/O	General-purpose digital I/O
20	P0.00	Digital I/O	General-purpose digital I/O
	AREF0	Analog input	ADC Reference voltage
21	P0.01	Digital I/O	General-purpose digital I/O
	AIN2	Analog input	ADC input 2
22	P0.02	Digital I/O	General-purpose digital I/O
	AIN3	Analog input	ADC input 3
23	P0.03	Digital I/O	General-purpose digital I/O
	AIN4	Analog input	ADC input 4
24	P0.04	Digital I/O	General-purpose digital I/O
	AIN5	Analog input	ADC input 5
25	P0.05	Digital I/O	General-purpose digital I/O
	AIN6	Analog input	ADC input 6
26	P0.06	Digital I/O	General-purpose digital I/O
	AIN7	Analog input	ADC input 7
	AREF1	Analog input	ADC Reference voltage
27	P0.07	Digital I/O	General-purpose digital I/O
28	N.C.	/	/
29	GND	Ground	The pad must be connected to a solid ground plane
30	P0.08	Digital I/O	General-purpose digital I/O
31	P0.09	Digital I/O	General-purpose digital I/O
32	P0.10	Digital I/O	General-purpose digital I/O
33	P0.11	Digital I/O	General-purpose digital I/O
34	P0.12	Digital I/O	General-purpose digital I/O
35	P0.13	Digital I/O	General-purpose digital I/O
36	P0.14	Digital I/O	General-purpose digital I/O
37	P0.15	Digital I/O	General-purpose digital I/O
38	P0.16	Digital I/O	General-purpose digital I/O

Pin NO.	Name	Pin function	Description
39	P0.17	Digital I/O	General-purpose digital I/O
40	SWDIO	Digital I/O	Also HW debug and flash programming I/O
	RESET	Digital I/O	System reset(active low).
41	SWDCLK	Digital input	HW debug and flash programming. Connect a 12K ohm resistor to GND for flash programming .
42	P0.18	Digital I/O	General-purpose digital I/O
43	P0.19	Digital I/O	General-purpose digital I/O
44	P0.20	Digital I/O	General-purpose digital I/O
45	GND	Ground	The pad must be connected to a solid ground plane
46	GND	Ground	The pad must be connected to a solid ground plane

- Digital I/O pad with 5mA source/sink capability.

Table 1 : Pin function (ISBLE1810-P51xxxxxA)

- ISBLE1506-A51xxxxxA**

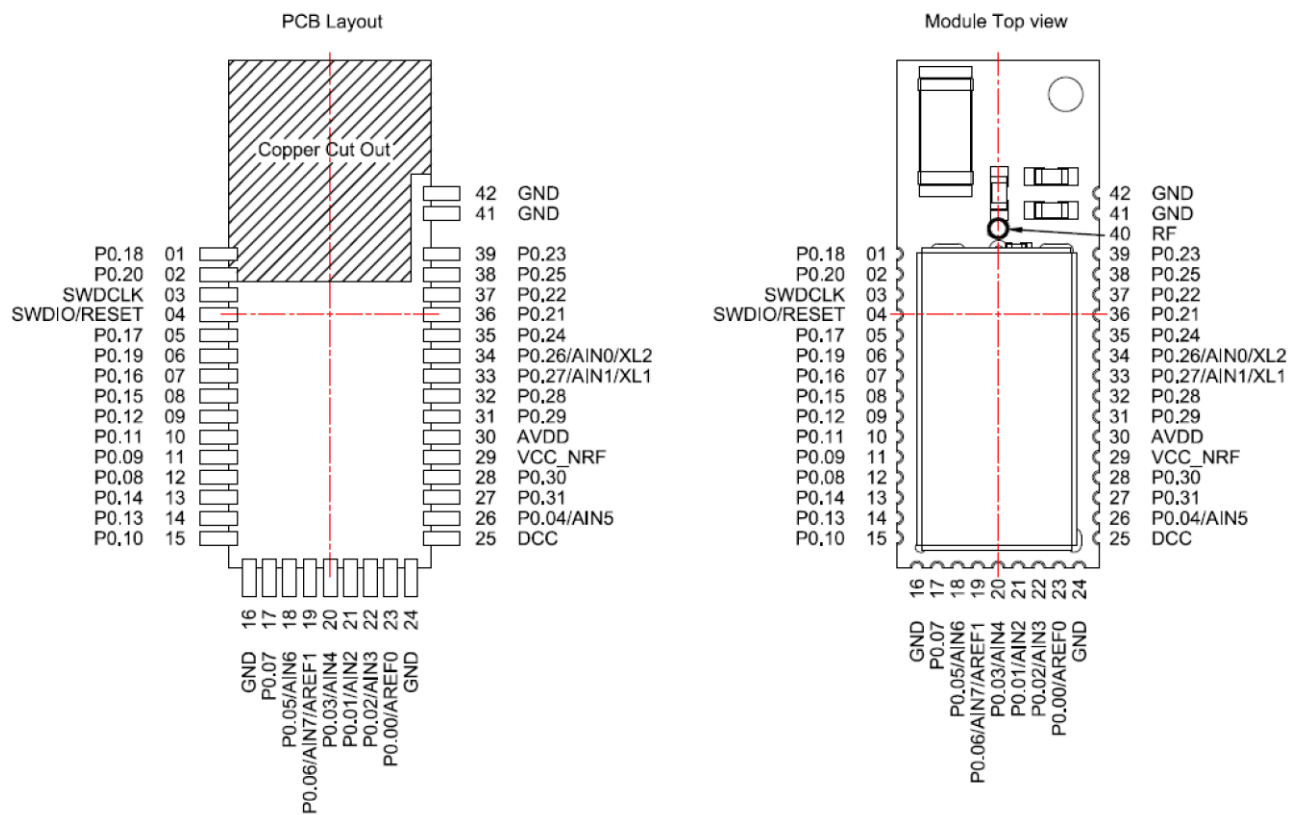

Figure 5 : Module Pin Descriptions (ISBLE1506-A51xxxxxA)

Pin NO.	Name	Pin function	Description
1	P0.18	Digital I/O	General-purpose digital I/O
2	P0.20	Digital I/O	General-purpose digital I/O
3	SWDCLK	Digital input	HW debug and flash programming. Connect a 12K ohm resistor to GND for flash programming .
4	SWDIO	Digital I/O	Also HW debug and flash programming I/O
	RESET	Digital I/O	System reset(active low)
5	P0.17	Digital I/O	General-purpose digital I/O
6	P0.19	Digital I/O	General-purpose digital I/O
7	P0.16	Digital I/O	General-purpose digital I/O
8	P0.15	Digital I/O	General-purpose digital I/O
9	P0.12	Digital I/O	General-purpose digital I/O
10	P0.11	Digital I/O	General-purpose digital I/O
11	P0.09	Digital I/O	General-purpose digital I/O
12	P0.08	Digital I/O	General-purpose digital I/O
13	P0.14	Digital I/O	General-purpose digital I/O
14	P0.13	Digital I/O	General-purpose digital I/O
15	P0.10	Digital I/O	General-purpose digital I/O
16	GND	Ground	The pad must be connected to a solid ground plane
17	P0.07	Digital I/O	General-purpose digital I/O
18	P0.05	Digital I/O	General-purpose digital I/O
	AIN6	Analog input	ADC input 6
19	P0.06	Digital I/O	General-purpose digital I/O
	AIN7	Analog input	ADC input 7
	AREF1	Analog input	ADC Reference voltage
20	P0.03	Digital I/O	General-purpose digital I/O
	AIN4	Analog input	ADC input 4
21	P0.01	Digital I/O	General-purpose digital I/O
	AIN2	Analog input	ADC input 2
22	P0.02	Digital I/O	General-purpose digital I/O
	AIN3	Analog input	ADC input 3
23	P0.00	Digital I/O	General-purpose digital I/O
	AREF0	Analog input	ADC Reference voltage
24	GND	Ground	The pad must be connected to a solid ground plane
25	DCC	Power	DC/DC output voltage to external LC filter
26	P0.04	Digital Input	General-purpose digital I/O
	AIN5	Analog input	ADC input 5

Pin NO.	Name	Pin function	Description
27	P0.31	Digital I/O	General-purpose digital I/O
28	P0.30	Digital I/O	General-purpose digital I/O
29	VCC_nRF	Power	Power supply
30	AVDD	Power	Analog power supply
31	P0.29	Digital I/O	General-purpose digital I/O
32	P0.28	Digital I/O	General-purpose digital I/O
33	P0.27	Digital I/O	General-purpose digital I/O
	AIN1	Analog input	ADC input 1
	XL1	Analog input	Connector for 32.768KHz crystal
34	P0.26	Digital I/O	General-purpose digital I/O
	AIN0	Analog input	ADC input 0
	XL2	Analog output	Connector for 32.768KHz crystal
35	P0.24	Digital I/O	General-purpose digital I/O
36	P0.21	Digital I/O	General-purpose digital I/O
37	P0.22	Digital I/O	General-purpose digital I/O
38	P0.25	Digital I/O	General-purpose digital I/O
39	P0.23	Digital I/O	General-purpose digital I/O
40	RF	RFout	2.4GHz 50ohm RF out, not need to mount.
41	GND	Ground	The pad must be connected to a solid ground plane
42	GND	Ground	The pad must be connected to a solid ground plane

1. Digital I/O pad with 5mA source/sink capability.

Table 2 : Pin function (ISBLE1506-A51xxxxxA)

3.3 PCB Layout Guide

- ISBLE1810-P51xxxxxA

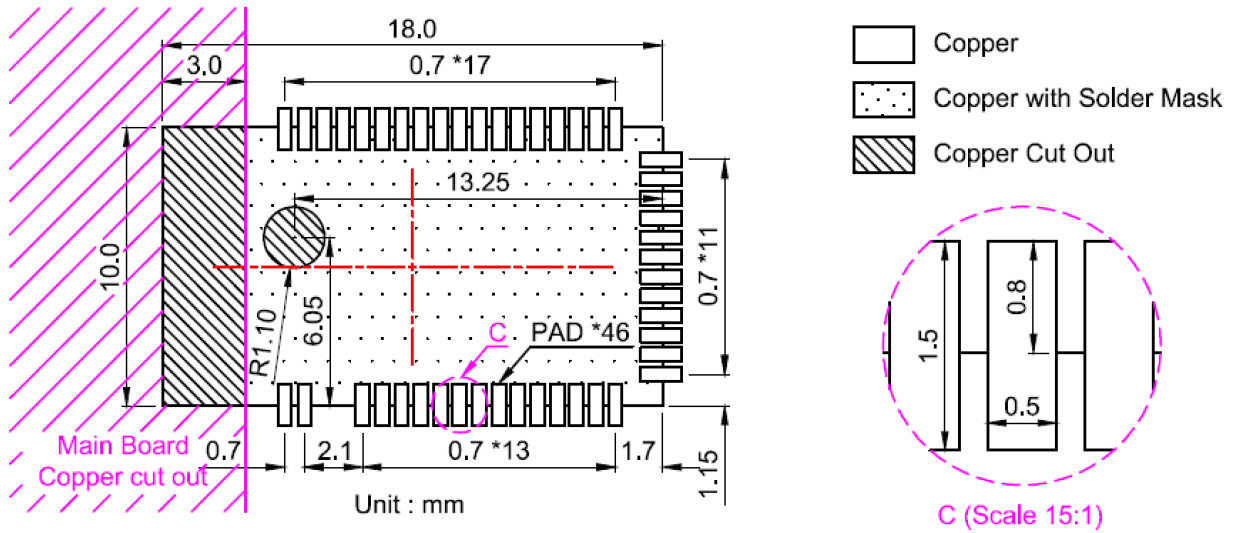

Figure 6 : PCB Layout Guide (ISBLE1810-P51xxxxxA)

- ISBLE1506-A51xxxxxA

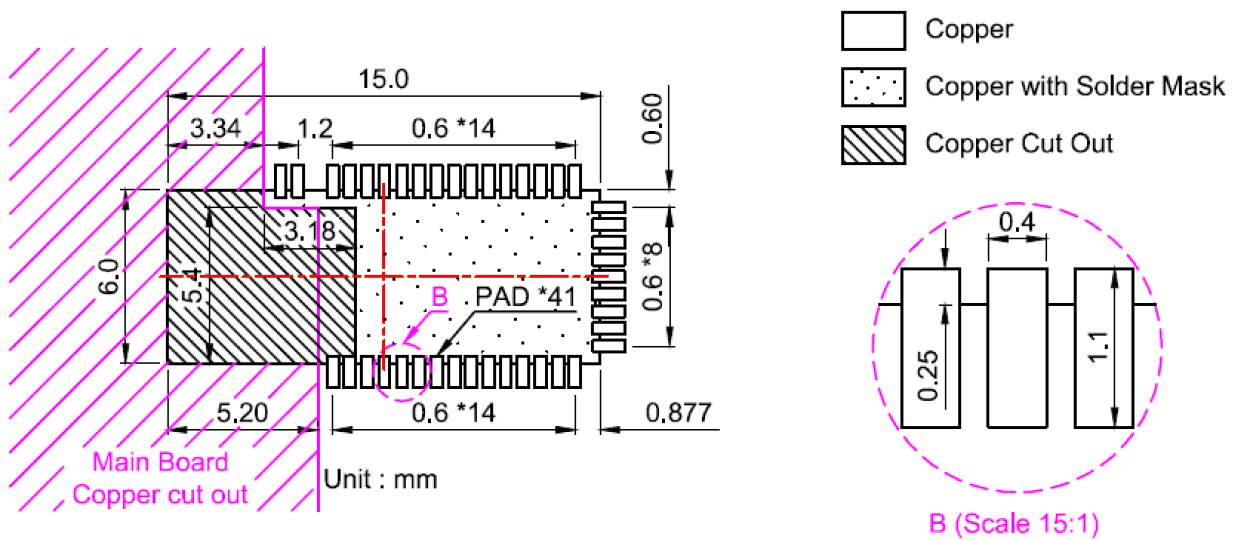

Figure 7 : PCB Layout Guide (ISBLE1506-A51xxxxxA)

4. Main Chip Solution

RF IC	Crystal Frequency
Nordic nRF51822-QFAA	16MHz
Nordic nRF51822-CEAA	16MHz

Table 3 : Main Chip Solution

5. Shipment Packing Information

Part Number	Package
ISBLE1810-P51822ACA	500 PCS/BOX
ISBLE1506-A51822ACA	500 PCS/BOX

Table 4 : Shipment Packing Information

- ISBLE1810-P51xxxxxA

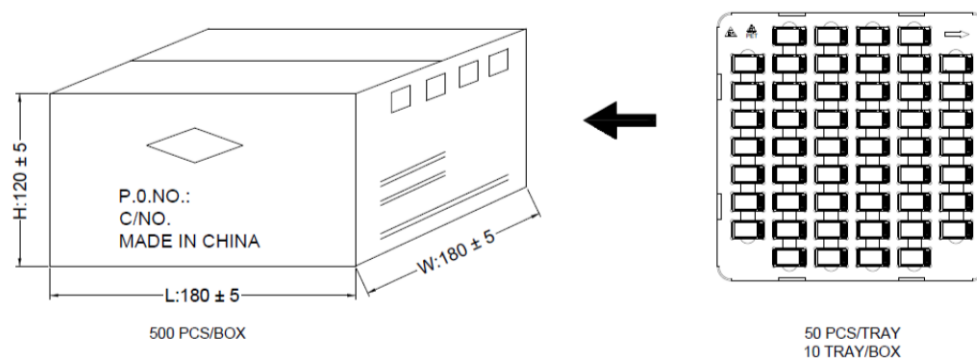

Figure 8 : Packing Information (ISBLE1810-P51xxxxxA)

- ISBLE1506-A51xxxxxA

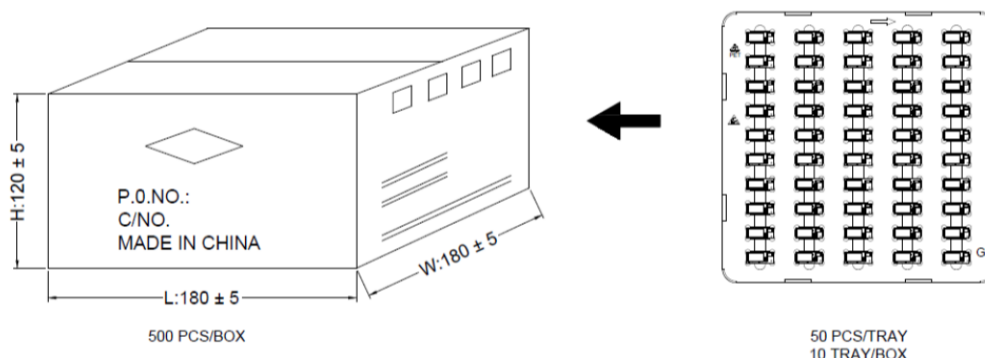

Figure 9 : Packing Information (ISBLE1810-P51xxxxxA)

6. Specification

6.1 Absolute Maximum Ratings

Maximum ratings are the extreme limits the chip can be exposed to without causing permanent damage. Exposure to absolute maximum ratings for prolonged periods of time may affect the reliability of the chip.

Table 5 specifies the absolute maximum ratings.

Symbol	Parameter	Min.	Max.	Units
Supply voltages				
VDD		-0.3	+3.9	V
DEC2			2	V
VSS			0	V
I/O pin voltage				
VIO		-0.3	VDD+0.3	V
Environmental QFN48 package				
Storage temperature		-40	+125	°C
MSL	Moisture Sensitivity Level		2	
ESD HBM	Human Body Model		3	kV
ESD CDM	Charged Device Model		750	V
Environmental WLCSP package				
Storage temperature		-40	+125	°C
MSL	Moisture Sensitivity Level		1	
ESD HBM	Human Body Model		4	kV
ESD CDM	Charged Device Model		500	V
Flash memory				
Endurance		20000 ¹		Write / erase cycles
Retention		10 years at 40 °C 50 years at 25 °C		
Number of times an address can be written between erase cycles			2	times

1. Flash endurance is 20,000 erase cycles. The smallest element of flash that can be written is a 32 bit word.

Table 5 : Absolute maximum ratings

6.2 Operation Conditions

The operating conditions are the physical parameters that the chip can operate within as defined in Table 6.

Symbol	Parameter	Notes	Min.	Typ.	Max.	Units
VDD	Supply voltage, internal LDO setup		1.8	3.0	3.6	V
VDD	Supply voltage, DC/DC converter setup		2.1	3.0	3.6	V
VDD	Supply voltage, low voltage mode setup	1	1.75	1.8	1.95	V
t_{R_VDD}	Supply rise time (0 V to VDD)	2			100	ms
T_A	Operating temperature		-25	25	75	°C

1. DEC2 shall be connected to VDD in this mode.
2. The on-chip power-on reset circuitry may not function properly for rise times outside the specified interval.

Table 6 : Operating conditions

6.3 Electrical Specifications

6.3.1 Radio Transceiver

- General radio characteristics

Symbol	Parameter	Notes	Min.	Typ.	Max.	Units	Test Level
f_{OP}	Operating frequencies.	1 MHz channel spacing	2400		2483	MHz	N/A
PLL_{res}	PLL programming resolution.			1		MHz	N/A
Δf_{250}	Frequency deviation at 250 kbps.			±170		kHz	2
Δf_{1M}	Frequency deviation at 1 Mbps.			±170		kHz	2
Δf_{2M}	Frequency deviation at 2 Mbps.			±320		kHz	2
Δf_{BLE}	Frequency deviation at BLE.		±225	±250	±275	kHz	4
bps_{FSK}	On-air data rate.		250		2000	kbps	N/A

Table 7 : General radio characteristics

- Radio current consumption

Symbol	Parameter	Notes	Min.	Typ.	Max.	Units	Test Level
$I_{TX,+4dBm}$	TX only run current at $P_{OUT} = +4$ dBm.	1		16		mA	4
$I_{TX,0dBm}$	TX only run current at $P_{OUT} = 0$ dBm.	1		10.5		mA	4
$I_{TX,-4dBm}$	TX only run current at $P_{OUT} = -4$ dBm.	1		8		mA	2
$I_{TX,-8dBm}$	TX only run current at $P_{OUT} = -8$ dBm.	1		7		mA	2

Symbol	Parameter	Notes	Min.	Typ.	Max.	Units	Test Level
$I_{TX,-12dBm}$	TX only run current at $P_{OUT} = -12$ dBm.	1		6.5		mA	2
$I_{TX,-16dBm}$	TX only run current at $P_{OUT} = -16$ dBm.	1		6		mA	2
$I_{TX,-20dBm}$	TX only run current at $P_{OUT} = -20$ dBm.	1		5.5		mA	2
$I_{TX,-30dBm}$	TX only run current at $P_{OUT} = -30$ dBm.	1		5.5		mA	2
$I_{START,TX}$	TX startup current.	2		7		mA	1
$I_{RX,250}$	RX only run current at 250 kbps.			12.6		mA	1
$I_{RX,1M}$	RX only run current at 1 Mbps.			13		mA	4
$I_{RX,2M}$	RX only run current at 2 Mbps.			13.4		mA	1
I_{START}	RX startup current.	3		8.7		mA	1

1. Valid for data rates 250 kbps, 1 Mbps, and 2 Mbps.
2. Average current consumption (at 0 dBm TX output power) for TX startup (130 μ s), and when changing mode from RX to TX (130 μ s).
3. Average current consumption for RX startup (130 μ s), and when changing mode from TX to RX (130 μ s).

Table 8 : Radio current consumption

6.3.2 Transmitter Specifications

Symbol	Description	Min.	Typ.	Max.	Units	Test Level
P_{RF}	Maximum output power.		4		dBm	4
P_{RFC}	RF power control range.	20	24		dB	2
P_{RFCR}	RF power accuracy.			± 4	dB	1
P_{WHISP}	RF power whisper mode.		-30		dBm	2
P_{BW2}	20 dB bandwidth for modulated carrier (2 Mbps).		1800	2000	kHz	2
P_{BW1}	20 dB bandwidth for modulated carrier (1 Mbps).		950	1100	kHz	2
P_{BW250}	20 dB bandwidth for modulated carrier (250 kbps).		700	800	kHz	2
$P_{RF1.2}$	1st Adjacent Channel Transmit Power. ± 2 MHz (2 Mbps).			-20	dBc	2
$P_{RF2.2}$	2nd Adjacent Channel Transmit Power. ± 4 MHz (2 Mbps).			-45	dBc	2
$P_{RF1.1}$	1st Adjacent Channel Transmit Power. ± 1 MHz (1 Mbps).			-20	dBc	2
$P_{RF2.1}$	2nd Adjacent Channel Transmit Power. ± 2 MHz (1 Mbps).			-40	dBc	2
$P_{RF1.250}$	1st Adjacent Channel Transmit Power. ± 1 MHz (250 kbps).			-25	dBc	2
$P_{RF2.250}$	2nd Adjacent Channel Transmit Power. ± 2 MHz (250 kbps).			-40	dBc	2

Symbol	Description	Min.	Typ.	Max.	Units	Test Level
$t_{TX,30}$	Maximum consecutive transmission time, $f_{TOL} < \pm 30$ ppm.			16	ms	1
$t_{TX,60}$	Maximum consecutive transmission time, $f_{TOL} < \pm 60$ ppm.			4	ms	1

Table 9 : Transmitter specifications

6.3.3 Receiver Specifications

Symbol	Description	Min.	Typ.	Max.	Units	Test Level
Receiver operation						
PRX_{MAX}	Maximum received signal strength at < 0.1% PER.		0		dBm	1
$PRX_{SENS,2M}$	Sensitivity (0.1% BER) at 2 Mbps.		-85		dBm	2
$PRX_{SENS,1M}$	Sensitivity (0.1% BER) at 1 Mbps.		-90		dBm	2
$PRX_{SENS,250k}$	Sensitivity (0.1% BER) at 250 kbps.		-96		dBm	2
$P_{SENS IT}$ 1 Mbps BLE	Receiver sensitivity: Ideal transmitter.		-93		dBm	2
$P_{SENS DT}$ 1 Mbps BLE	Receiver sensitivity: Dirty transmitter.1		-91		dBm	2
RX selectivity - modulated interfering signal²						
2 Mbps						
C/I_{CO}	C/I co-channel.		12		dB	2
C/I_{1ST}	1 st ACS, C/I 2 MHz.		-4		dB	2
C/I_{2ND}	2 nd ACS, C/I 4 MHz.		-24		dB	2
C/I_{3RD}	3 rd ACS, C/I 6 MHz.		-28		dB	2
C/I_{6th}	6 th ACS, C/I 12 MHz.		-44		dB	2
C/I_{Nth}	N th ACS, C/I $f_i > 25$ MHz.		-50		dB	2
1 Mbps						
C/I_{CO}	C/I co-channel (1 Mbps).		12		dB	2
C/I_{1ST}	1 st ACS, C/I 1 MHz.		4		dB	2
C/I_{2ND}	2 nd ACS, C/I 2 MHz.		-24		dB	2
C/I_{3RD}	3 rd ACS, C/I 3 MHz.		-30		dB	2
C/I_{6th}	6 th ACS, C/I 6 MHz.		-40		dB	2
C/I_{12th}	12 th ACS, C/I 12 MHz.		-50		dB	2
C/I_{Nth}	N th ACS, C/I $f_i > 25$ MHz.		-53		dB	2

Symbol	Description	Min.	Typ.	Max.	Units	Test Level
250 kbps						
C/I_{CO}	C/I co-channel.		4		dB	2
C/I_{1ST}	1 st ACS, C/I 1 MHz.		-10		dB	2
C/I_{2ND}	2 nd ACS, C/I 2 MHz.		-34		dB	2
C/I_{3RD}	3 rd ACS, C/I 3 MHz.		-39		dB	2
C/I_{6th}	6 th ACS, C/I $f_i > 6$ MHz.		-50		dB	2
C/I_{12th}	12 th ACS, C/I 12 MHz.		-55		dB	2
C/I_{Nth}	N^{th} ACS, C/I $f_i > 25$ MHz.		-60		dB	2
Bluetooth Low Energy RX selectivity						
C/I_{CO}	C/I co-channel.		10		dB	2
C/I_{1ST}	1 st ACS, C/I 1 MHz.		1		dB	2
C/I_{2ND}	2 nd ACS, C/I 2 MHz.		-25		dB	2
C/I_{3+N}	ACS, C/I (3+n) MHz offset [n = 0, 1, 2, . . .].		-51		dB	2
C/I_{Image}	Image blocking level.		-30		dB	2
$C/I_{Image\pm 1MHz}$	Adjacent channel to image blocking level (± 1 MHz).		-31		dB	2
RX intermodulation³						
P_IMD_{2Mbps}	IMD performance, 2 Mbps, 3rd, 4th, and 5th offset channel.		-41		dBm	2
P_IMD_{1Mbps}	IMD performance, 1 Mbps, 3rd, 4th, and 5th offset channel.		-40		dBm	2
$P_IMD_{250kbps}$	IMD performance, 250 kbps, 3rd, 4th, and 5th offset channel.		-36		dBm	2
P_IMD_{BLE}	IMD performance, 1 Mbps BLE, 3rd, 4th, and 5th offset channel.		-39		dBm	2

1. As defined in the Bluetooth Core Specification v4.0 Volume 6: Core System Package (Low Energy Controller Volume).
2. Wanted signal level at PIN = -67 dBm. One interferer is used, having equal modulation as the wanted signal. The input power of the interferer where the sensitivity equals BER = 0.1% is presented.
3. Wanted signal level at PIN = -64 dBm. Two interferers with equal input power are used. The interferer closest in frequency is not modulated, the other interferer is modulated equal with the wanted signal. The input power of interferers where the sensitivity equals BER = 0.1% is presented.

Table 10 : Receiver specifications

6.3.4 Radio Timing Parameters

Symbol	Description	250 k	1 M	2 M	BLE	Jitter	Units
t_{TXEN}	Time between TXEN task and READY event.	132	132	132	140	0	μs
$t_{TXDISABLE}$	Time between DISABLE task and DISABLED event when the radio was in TX.	10	4	3	4	1	μs
t_{RXEN}	Time between the RXEN task and READY event.	130	130	130	138	0	μs
$t_{RXDISABLE}$	Time between DISABLE task and DISABLED event when the radio was in RX.	0	0	0	0	1	μs
$t_{TXCHAIN}$	TX chain delay.	5	1	0.5	1	0	μs
$t_{RXCHAIN}$	RX chain delay.	12.5	3	2	3	0	μs

Table 11 : Radio timing

6.3.5 RSSI Specifications

Symbol	Description	Notes	Min.	Typ.	Max.	Units	Test Level
$RSSI_{ACC}$	RSSI accuracy.	Valid range -50 dBm to -80 dBm.			± 6	dB	2
$RSSI_{RESOLUTION}$	RSSI resolution.			1		dB	1
$RSSI_{PERIOD}$	Sample period.		8.8			μs	1
$RSSI_{CURRENT}$	Current consumption in addition to IRX.			250		μA	1

Table 12 : RSSI specifications

6.3.6 CPU

Symbol	Description	Min.	Typ.	Max.	Units	Test Level
$I_{CPU, FLASH}$	Run current at 16 MHz (XOSC). Executing code from flash memory.		4.1		mA	2
$I_{CPU, RAM}$	Run current at 16 MHz (XOSC). Executing code from RAM.		2.4		mA	1
$I_{START, CPU}$	CPU startup current.		600		μA	1
$t_{START, CPU}$	IDLE to CPU execute.	0			μs	1

Table 13 : RSSI specifications

6.3.7 Power Management

Symbol	Description	Min.	Typ.	Max.	Units	Test Level
I_{OFF}	Current in SYSTEM OFF, no RAM retention.		0.6 ¹		μA	2
$I_{OFF, RET, 8k}$	Additional current in SYSTEM OFF per retained RAM block (8 kB).		0.6 ¹		μA	2
I_{OFF2ON}	OFF to CPU execute transition current.		400		μA	1
t_{OFF2ON}	OFF to CPU execute.		9.6	10.6	μs	1
$I_{ON,16k}$	SYSTEM-ON base current with 16 kB RAM enabled.		2.6 ¹		μA	2
$I_{ON,32k}$	SYSTEM-ON base current with 32 kB RAM enabled.		3.8 ¹		μA	2
t_{1V2}	Startup time for 1V2 regulator.		2.3		μs	1
$I_{1V2XO16}$	Current drawn by 1V2 regulator and 16 MHz XOSC when both are on at the same time.		810 ²		μA	1
$I_{1V2XO32}$	Current drawn by 1V2 regulator and 32 MHz XOSC when both are on at the same time.		840 ²		μA	1
$I_{1V2RC16}$	Current drawn by 1V2 regulator and 16 MHz RCOSC when both are on at the same time.		880 ²		μA	1
$I_{1V2XO16,1M}$	For HFCLK in 1 MHz mode3. Current drawn by 1V2 regulator and 16 MHz XOSC when both are on at the same time.		520 ²		μA	1
$I_{1V2XO32,1M}$	For HFCLK in 1 MHz mode3. Current drawn by 1V2 regulator and 32 MHz XOSC when both are on at the same time.		560 ²		μA	1
$I_{1V2RC16,1M}$	For HFCLK in 1 MHz mode3. Current drawn by 1V2 regulator and 16 MHz RCOSC when both are on at the same time.		630 ²		μA	1
t_{XO}	Startup time for the clock management system when the XTAL is in standby.		2.3		μs	1
t_{1V7}	Startup time for 1V7 regulator.		2	3.6	μs	1
I_{1V7}	Current drawn by 1V7 regulator.		105		μA	2
F_{DCDC}	DC/DC converter current conversion factor.	0.65 ⁴		1.2 ⁴		1

1. Add 1 μA to the current value if the device is used in Low voltage mode.
2. This number includes the current used by the automated power and clock management system.
3. For details on 1 MHz mode, see Section 4.2 "Timer/counters (TIMER)" on page 33.
4. FDCDC will vary depending on VDD and internal radio current consumption (IDD). Please refer to the nRF51 Series Reference Manual, v3.0 or later, for a method to calculate IDD,DCDC. See Figure 11 on page 51 for a DC/DC conversion factor chart.

Table 14 : Power management

7. Reference Circuit

7.1 Schematic with Internal LDO

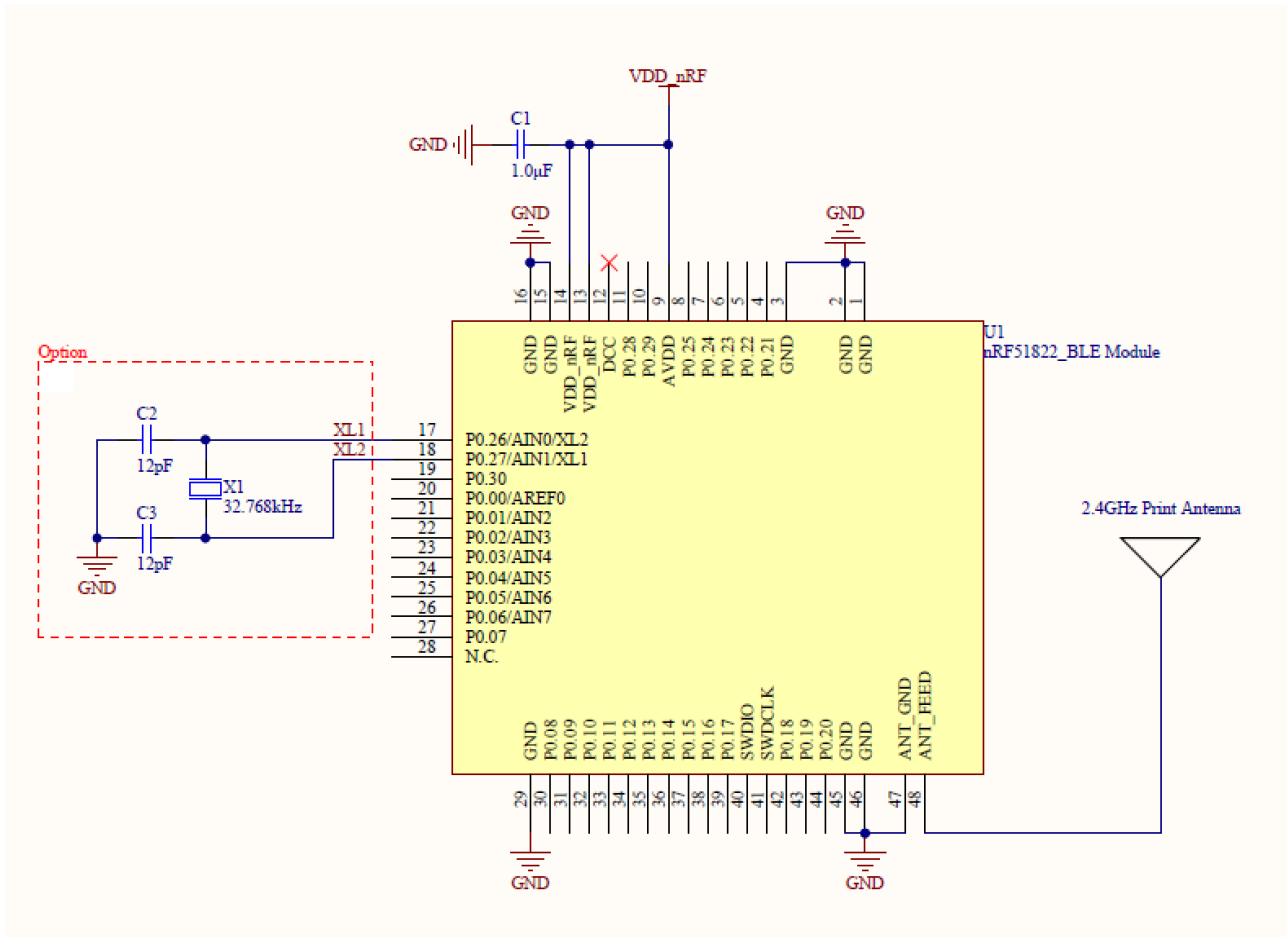

Figure 10 : Schematic with internal LDO

7.2 Schematic with Internal DC/DC Converter

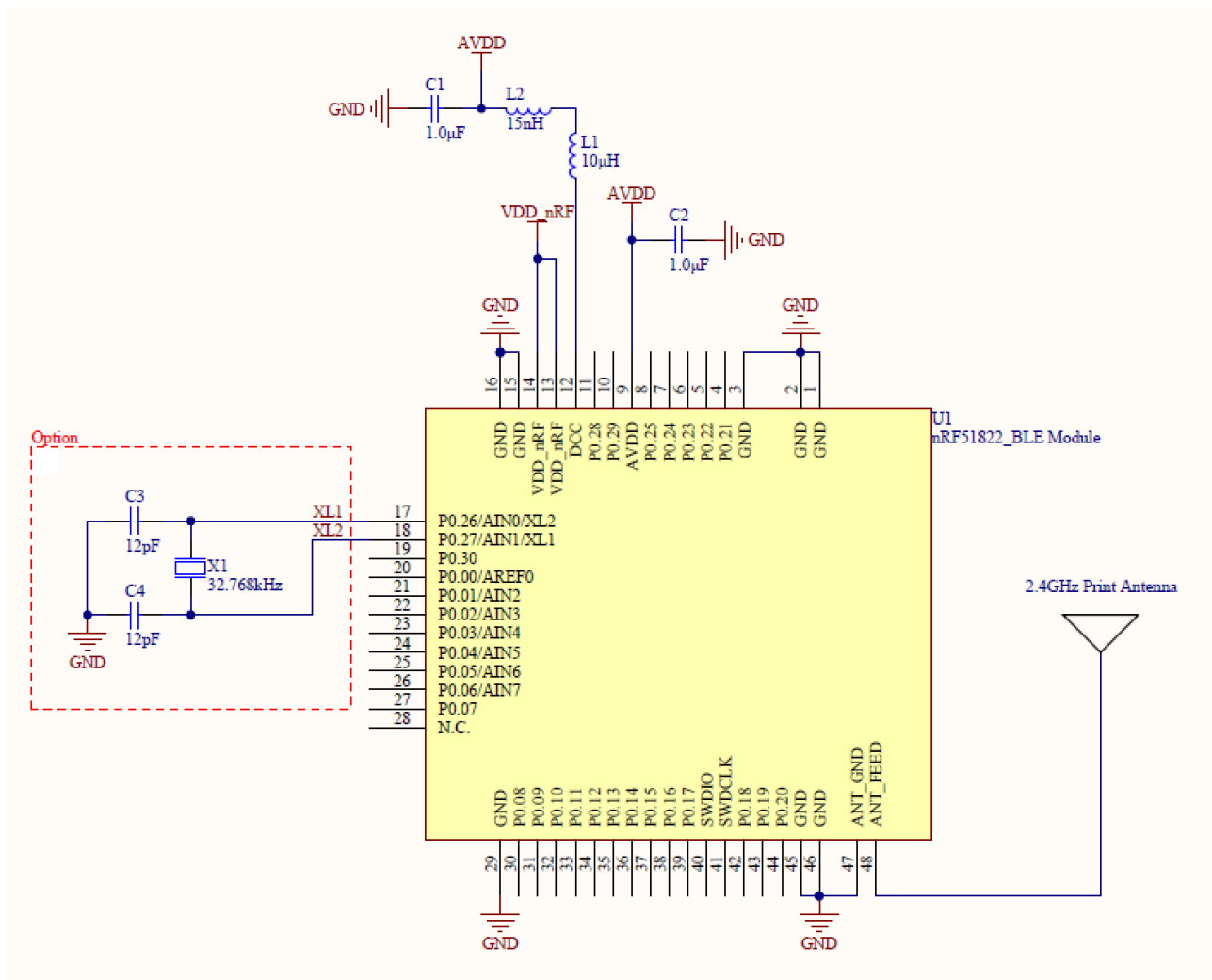

Figure 11 : Schematic with internal DC/DC converter

8. Development Kit

- Development Kit for ISBLE1810

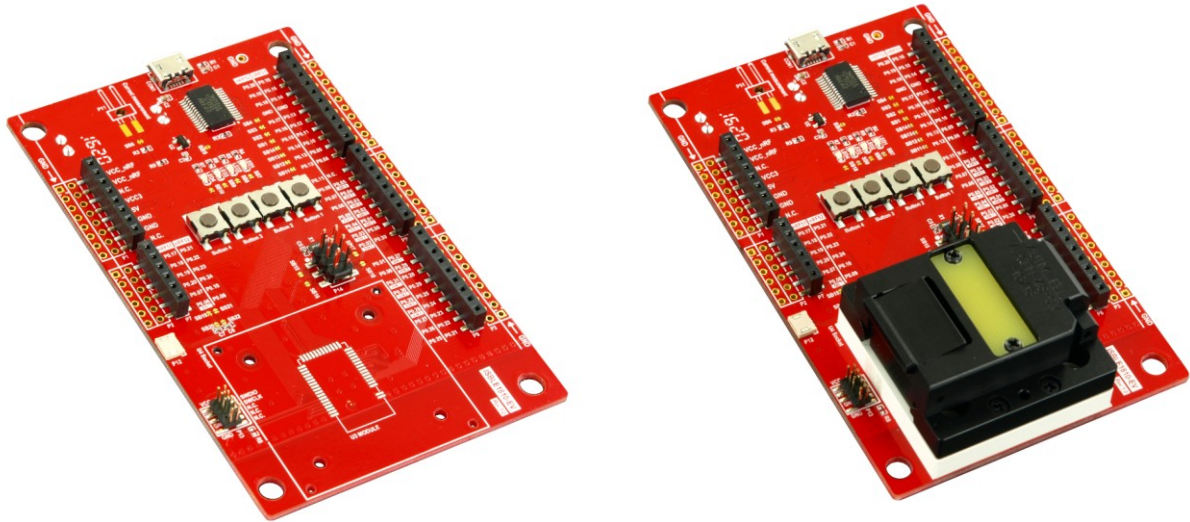

Figure 12 : Development Kit for ISBLE1810

- Support USB to UART for DTM use
- Button *4 and LED *4
- 32 Pin GPIO to 2.54mm Female Pin Holder
- Support Module Test Socket

- **Development Kit for ISBLE1506**

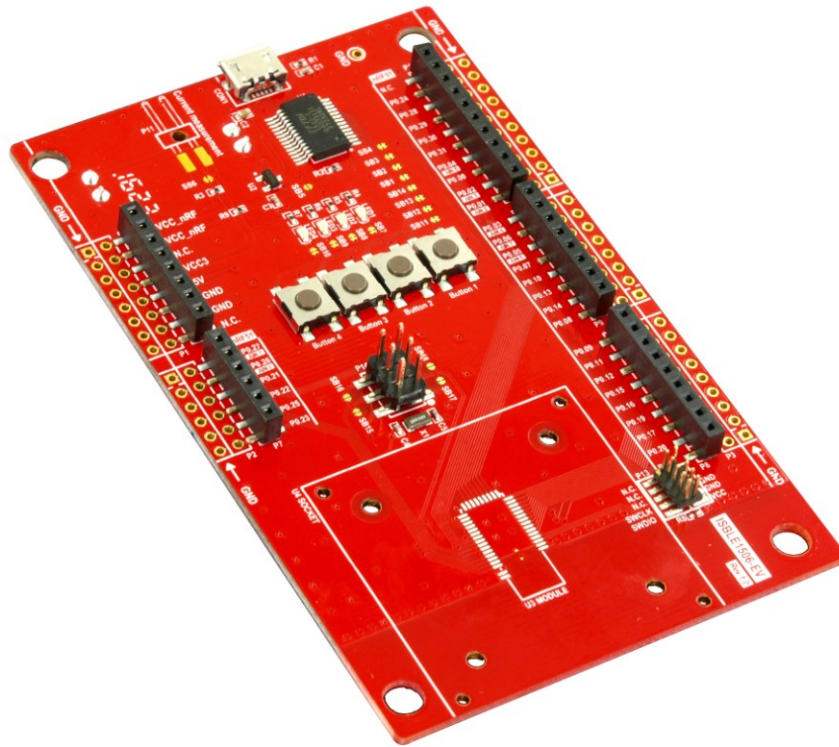

Figure 13 : Development Kit for ISBLE1506

- Support USB to UART for DTM use
- Button *4 and LED *4
- 32 Pin GPIO to 2.54mm Female Pin Holder
- Support Module Test Socket

9. Antenna Forbidden Zone Description

The PCB and mechanism design need to meet antenna forbidden zone description Table. Otherwise affect the efficiency of the antenna.

- **ISBLE1810-P51xxxxxA**

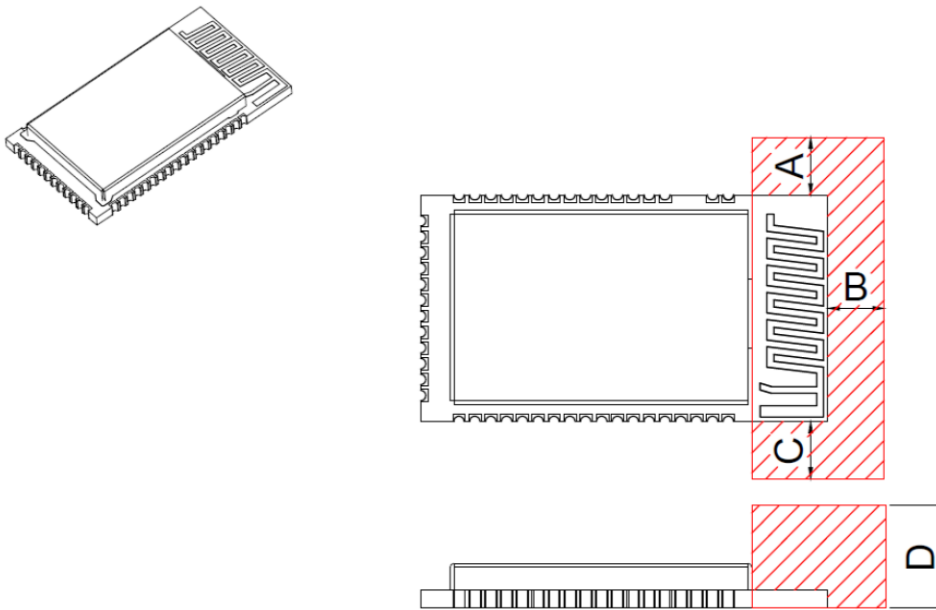

Figure 14 : Antenna Forbidden Zone Description (ISBLE1810-P51xxxxxA)

Material \ Dimension	A	B	C	D
FR4 (without Copper)	$\geq 1\text{mm}$	$\geq 3\text{mm}$	$\geq 1\text{mm}$	$\geq 3\text{mm}$
FR4 (with Copper)	$\geq 4\text{mm}$	$\geq 7\text{mm}$	$\geq 10\text{mm}$	$\geq 4\text{mm}$
Metal	$\geq 4\text{mm}$	$\geq 3.5\text{mm}$	$\geq 10\text{mm}$	$\geq 3\text{mm}$
Plastic	$\geq 1\text{mm}$	$\geq 1\text{mm}$	$\geq 1\text{mm}$	$\geq 3\text{mm}$

Table 15 : Antenna Forbidden Zone List (ISBLE1810-P51xxxxxA)

- ISBLE1506-A51xxxxxA

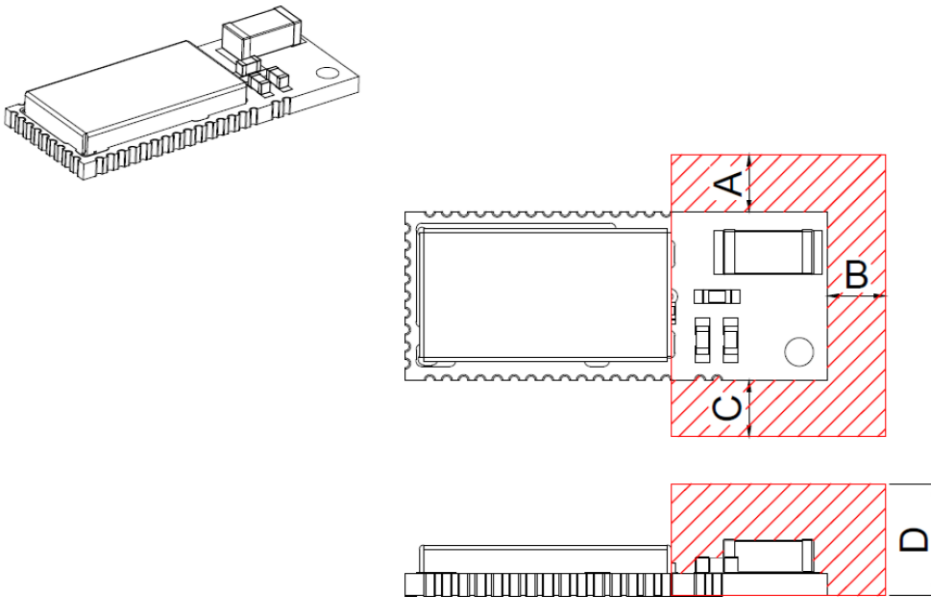

Figure 15 : Antenna Forbidden Zone Description (ISBLE1506-P51xxxxxA)

Material \ Dimension	A	B	C	D
FR4 (without Copper)	$\geq 2\text{mm}$	$\geq 3\text{mm}$	$\geq 0.5\text{mm}$	$\geq 5\text{mm}$
FR4 (with Copper)	$\geq 6\text{mm}$	$\geq 6\text{mm}$	$\geq 3\text{mm}$	$\geq 8\text{mm}$
Metal	$\geq 6\text{mm}$	$\geq 6\text{mm}$	$\geq 3\text{mm}$	$\geq 8\text{mm}$
Plastic	$\geq 2\text{mm}$	$\geq 2\text{mm}$	$\geq 0.5\text{mm}$	$\geq 3.5\text{mm}$

Table 16 : Antenna Forbidden Zone List (ISBLE1506-P51xxxxxA)

10. Statements

Federal Communications Commission (FCC) Statement

15.21

You are cautioned that changes or modifications not expressly approved by the part responsible for compliance could void the user's authority to operate the equipment.

15.105(b)

This equipment has been tested and found to comply with the limits for a Class B digital device, pursuant to part 15 of the FCC rules. These limits are designed to provide reasonable protection against harmful interference in a residential installation. This equipment generates, uses and can radiate radio frequency energy and, if not installed and used in accordance with the instructions, may cause harmful interference to radio communications. However, there is no guarantee that interference will not occur in a particular installation. If this equipment does cause harmful interference to radio or television reception, which can be determined by turning the equipment off and on, the user is encouraged to try to correct the interference by one or more of the following measures:

- Reorient or relocate the receiving antenna.
- Increase the separation between the equipment and receiver.
- Connect the equipment into an outlet on a circuit different from that to which the receiver is connected.
- Consult the dealer or an experienced radio/TV technician for help.

This device complies with Part 15 of the FCC Rules. Operation is subject to the following two conditions:

- 1) this device may not cause harmful interference, and
- 2) this device must accept any interference received, including interference that may cause undesired operation of the device.

FCC RF Radiation Exposure Statement :

This equipment complies with FCC radiation exposure limits set forth for an uncontrolled environment. End users must follow the specific operating instructions for satisfying RF exposure compliance. This transmitter must not be co-located or operating in conjunction with any other antenna or transmitter.

Note: The end product shall have the words "Contains Transmitter Module FCC ID: 2A12V-ISBLE1810X5 "

