

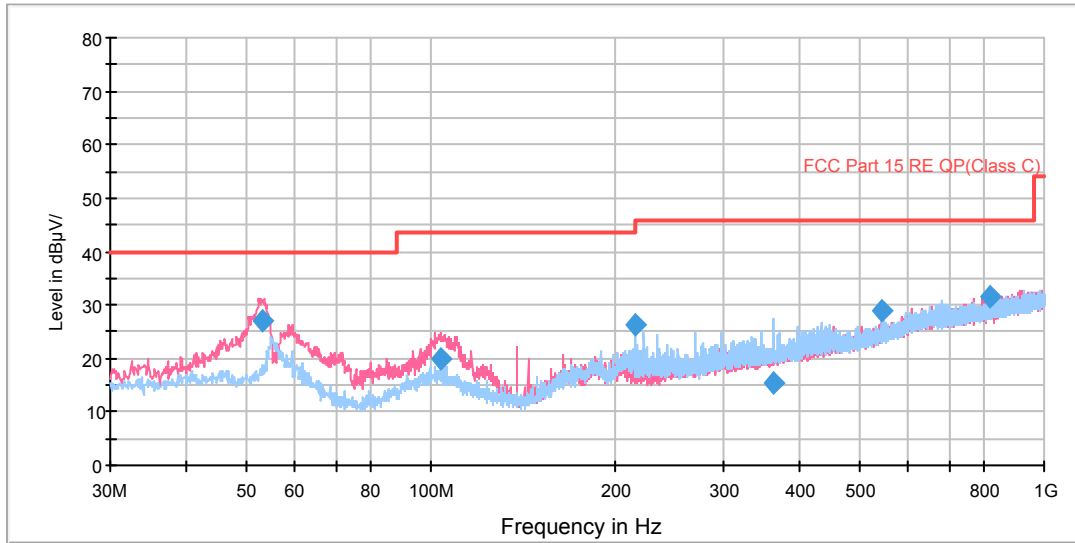

802.11g CH1

RE 0.03-1GHz QP Class B



Radiates Emission from 30MHz to 1GHz

Frequency (MHz)	Quasi-Peak (dBuV/m)	Height (cm)	Polarization	Azimuth (deg)	Reading value (dBuV/m)	Correct Factor (dB)	Margin (dB)	Limit (dBuV/m)
53.076250	27.0	100.0	V	332.0	39.8	12.8	13.0	40.0
103.721250	20.0	100.0	V	288.0	32.9	12.9	20.0	40.0
215.997500	26.3	125.0	H	326.0	39.0	12.7	13.7	40.0
363.072500	15.3	100.0	H	269.0	32.3	17.0	31.7	47.0
544.503750	28.9	125.0	H	250.0	49.8	20.9	18.1	47.0
816.751250	31.6	100.0	H	301.0	56.2	24.6	15.4	47.0

- Remark: 1. Quasi-Peak = Reading value + Correction factor
 2. Correction Factor = Antenna factor+ Insertion loss(cable loss+amplifier gain)
 3. Margin = Limit – Quasi-Peak

RE 1G-3GHz PK+AV

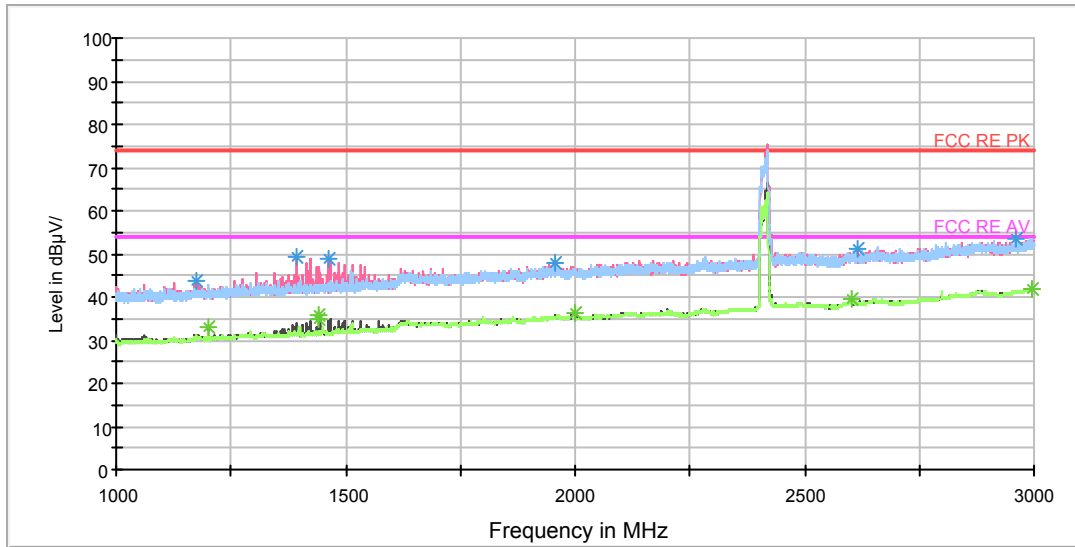

Note: The signal beyond the limit is carrier.

Radiates Emission from 1GHz to 3GHz

Frequency (MHz)	Peak (dBuV/m)	Height (cm)	Polarization	Azimuth (deg)	Reading value (dBuV/m)	Correct Factor (dB)	Margin (dB)	Limit (dBuV/m)
1175.750000	43.7	101.0	V	172.0	51.7	-8.0	30.3	74
1393.750000	49.1	101.0	V	219.0	56.1	-7.0	24.9	74
1462.500000	48.7	101.0	V	207.0	55.5	-6.8	25.3	74
1954.250000	47.8	101.0	V	322.0	51.4	-3.6	26.2	74
2614.000000	51.0	101.0	V	0.0	51.1	0.1	23.0	74
2958.750000	53.6	101.0	H	84.0	55.7	2.1	20.4	74

Remark: 1. Correction Factor = Antenna factor+ Insertion loss (cable loss + amplifier gain)

Frequency (MHz)	Average (dBuV/m)	Height (cm)	Polarization	Azimuth (deg)	Reading value (dBuV/m)	Correct Factor (dB)	Margin (dB)	Limit (dBuV/m)
1200.000000	32.9	101.0	V	65.0	41.1	-8.2	21.1	54
1442.000000	35.0	101.0	V	114.0	41.8	-6.8	19.0	54
1442.500000	35.8	101.0	V	114.0	42.6	-6.8	18.2	54
2000.000000	36.4	101.0	H	2.0	39.8	-3.4	17.6	54
2600.500000	39.4	101.0	V	207.0	39.8	0.4	14.6	54
2996.250000	42.1	101.0	V	77.0	44.4	2.3	11.9	54

Remark: 1. Correction Factor = Antenna factor+ Insertion loss (cable loss + amplifier gain)

RE 3-18GHz PK+AV

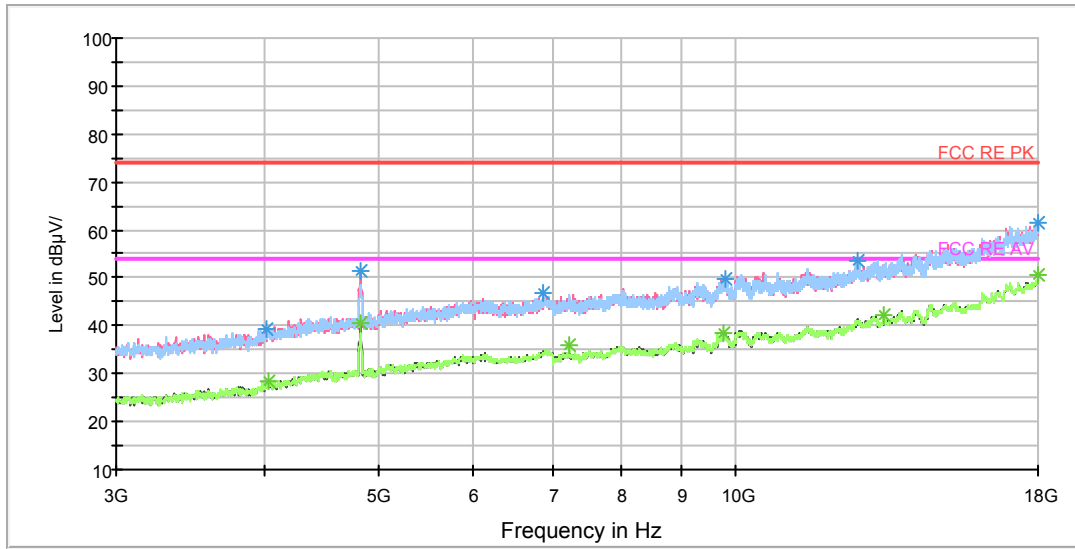

Radiates Emission from 3GHz to 18GHz

Frequency (MHz)	Peak (dBuV/m)	Height (cm)	Polarization	Azimuth (deg)	Reading value (dBuV/m)	Correct Factor (dB)	Margin (dB)	Limit (dBuV/m)
4023.750000	39.4	102.0	V	326.0	40.0	0.6	34.6	74
4828.125000	51.5	102.0	V	175.0	54.3	2.8	22.5	74
6866.250000	46.7	102.0	H	0.0	53.4	6.7	27.3	74
9817.500000	49.9	102.0	V	114.0	62.0	12.1	24.1	74
12693.750000	53.7	102.0	H	110.0	68.8	15.1	20.3	74
17971.875000	61.6	102.0	H	0.0	86.7	25.1	12.4	74

Remark: 1. Correction Factor = Antenna factor+ Insertion loss (cable loss + amplifier gain)

Frequency (MHz)	Average (dBuV/m)	Height (cm)	Polarization	Azimuth (deg)	Reading value (dBuV/m)	Correct Factor (dB)	Margin (dB)	Limit (dBuV/m)
4036.875000	28.3	102.0	V	144.0	28.9	0.6	25.7	54
4820.625000	40.6	102.0	V	175.0	43.3	2.7	13.4	54
7233.750000	35.8	102.0	H	157.0	44.5	8.7	18.2	54
9757.500000	38.4	102.0	V	48.0	50.1	11.7	15.6	54
13351.875000	42.0	102.0	H	20.0	57.8	15.8	12.0	54
17998.125000	50.5	102.0	V	266.0	75.9	25.4	3.5	54

Remark: 1. Correction Factor = Antenna factor+ Insertion loss (cable loss + amplifier gain)

RE 18-26.5GHz PK+AV

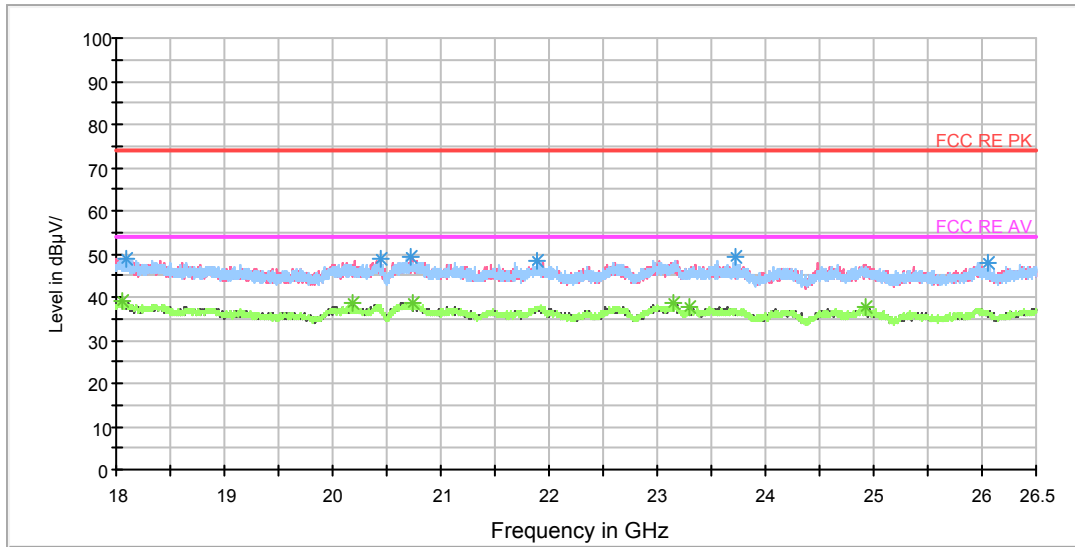

Radiates Emission from 18GHz to 26.5GHz

Frequency (MHz)	Peak (dBuV/m)	Height (cm)	Polarization	Azimuth (deg)	Reading value (dBuV/m)	Correct Factor (dB)	Margin (dB)	Limit (dBuV/m)
18087.125000	48.9	101.0	V	297.0	51.1	-2.2	25.1	74
20435.250000	48.6	101.0	V	0.0	54.7	-6.1	25.4	74
20714.687500	49.4	101.0	V	334.0	56.1	-6.7	24.6	74
21883.437500	48.5	101.0	V	346.0	56.5	-8.0	25.5	74
23718.375000	49.2	101.0	H	23.0	55.1	-5.9	24.8	74
26049.500000	48.1	101.0	V	85.0	53.5	-5.4	25.9	74

Remark: 1. Correction Factor = Antenna factor+ Insertion loss (cable loss + amplifier gain)

Frequency (MHz)	Average (dBuV/m)	Height (cm)	Polarization	Azimuth (deg)	Reading value (dBuV/m)	Correct Factor (dB)	Margin (dB)	Limit (dBuV/m)
18053.125000	39.2	101.0	H	348.0	41.2	-2.0	14.8	54
20180.250000	38.5	101.0	V	260.0	44.3	-5.8	15.5	54
20743.375000	38.6	101.0	H	252.0	45.4	-6.8	15.4	54
23148.875000	38.7	101.0	H	0.0	44.8	-6.1	15.3	54
23295.500000	37.6	101.0	V	358.0	43.6	-6.0	16.4	54
24923.250000	37.5	101.0	H	23.0	43.4	-5.9	16.5	54

Remark: 1. Correction Factor = Antenna factor+ Insertion loss (cable loss + amplifier gain)



802.11g CH6

RE 0.03-1GHz QP Class B

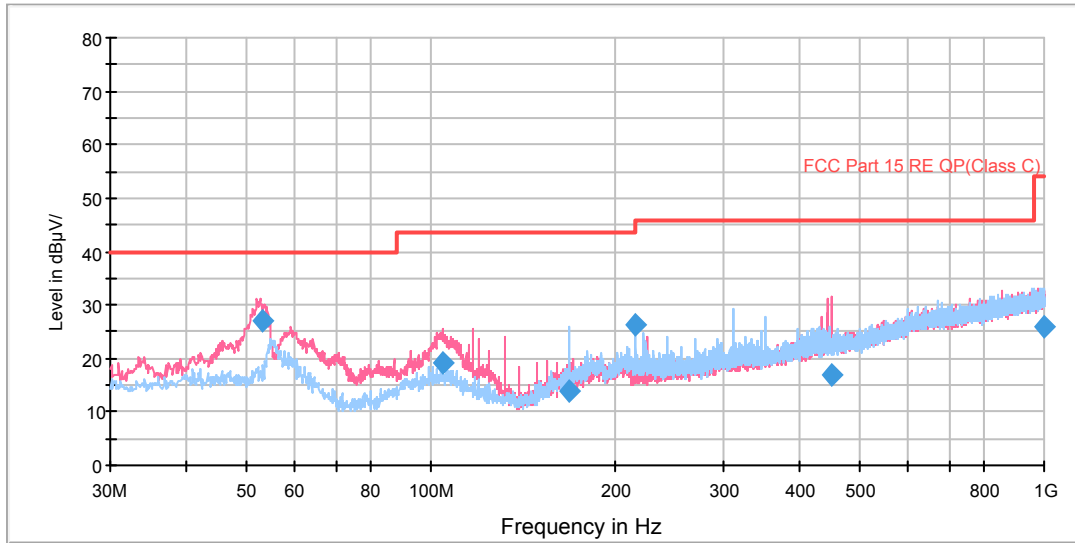

Radiates Emission from 30MHz to 1GHz

Frequency (MHz)	Quasi-Peak (dBuV/m)	Height (cm)	Polarization	Azimuth (deg)	Reading value (dBuV/m)	Correct Factor (dB)	Margin (dB)	Limit (dBuV/m)
53.073750	27.1	100.0	V	300.0	39.9	12.8	12.9	40.0
104.938750	19.3	100.0	V	0.0	32.1	12.8	20.7	40.0
168.343750	13.9	125.0	H	68.0	24.1	10.2	26.1	40.0
215.997500	26.4	125.0	H	314.0	39.1	12.7	13.6	40.0
450.418750	17.0	100.0	V	167.0	36.0	19.0	30.0	47.0
998.995000	26.1	100.0	H	288.0	52.6	26.5	20.9	47.0

- Remark:**
1. Quasi-Peak = Reading value + Correction factor
 2. Correction Factor = Antenna factor+ Insertion loss (cable loss+amplifier gain)
 3. Margin = Limit – Quasi-Peak

RE 1G-3GHz PK+AV

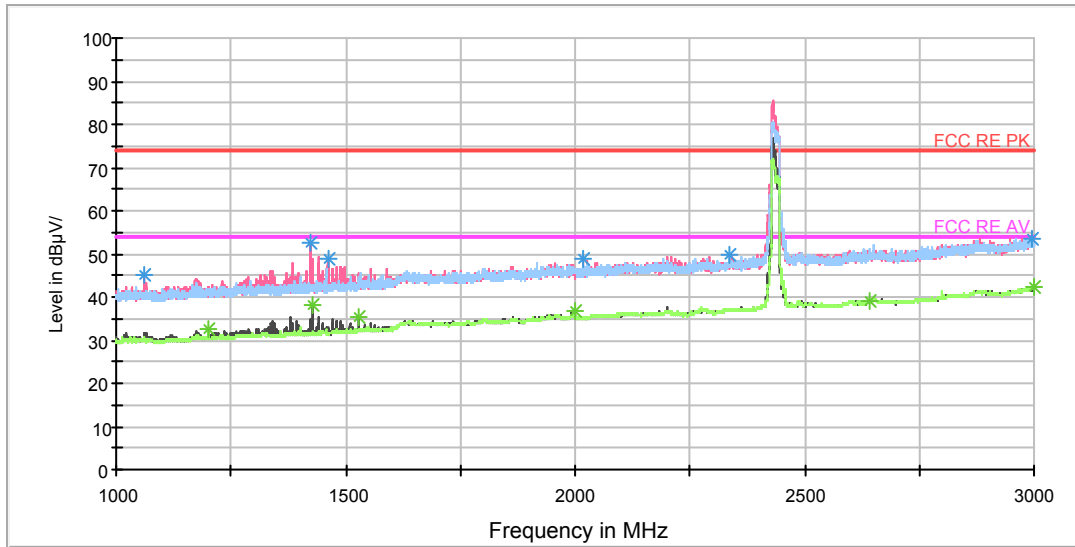

Note: The signal beyond the limit is carrier.
Radiates Emission from 1GHz to 3GHz

Frequency (MHz)	Peak (dBuV/m)	Height (cm)	Polarization	Azimuth (deg)	Reading value (dBuV/m)	Correct Factor (dB)	Margin (dB)	Limit (dBuV/m)
1061.750000	44.9	102.0	V	116.0	53.8	-8.9	29.1	74
1424.750000	52.8	102.0	V	0.0	59.7	-6.9	21.2	74
1460.750000	49.1	102.0	V	193.0	56.0	-6.9	24.9	74
2016.250000	48.6	102.0	V	0.0	52.2	-3.6	25.4	74
2337.250000	49.8	102.0	H	149.0	51.1	-1.3	24.2	74
2996.750000	53.7	102.0	V	0.0	56.0	2.3	20.3	74

Remark: 1. Correction Factor = Antenna factor+ Insertion loss (cable loss + amplifier gain)

Frequency (MHz)	Average (dBuV/m)	Height (cm)	Polarization	Azimuth (deg)	Reading value (dBuV/m)	Correct Factor (dB)	Margin (dB)	Limit (dBuV/m)
1200.000000	32.4	102.0	H	1.0	40.6	-8.2	21.6	54
1429.500000	38.4	102.0	V	161.0	45.3	-6.9	15.6	54
1530.000000	35.3	102.0	V	98.0	41.8	-6.5	18.7	54
2000.000000	36.8	102.0	H	10.0	40.2	-3.4	17.2	54
2640.000000	39.2	102.0	V	266.0	39.4	0.2	14.8	54
3000.000000	42.2	102.0	V	358.0	44.5	2.3	11.8	54

Remark: 1. Correction Factor = Antenna factor+ Insertion loss (cable loss + amplifier gain)

RE 3-18GHz PK+AV

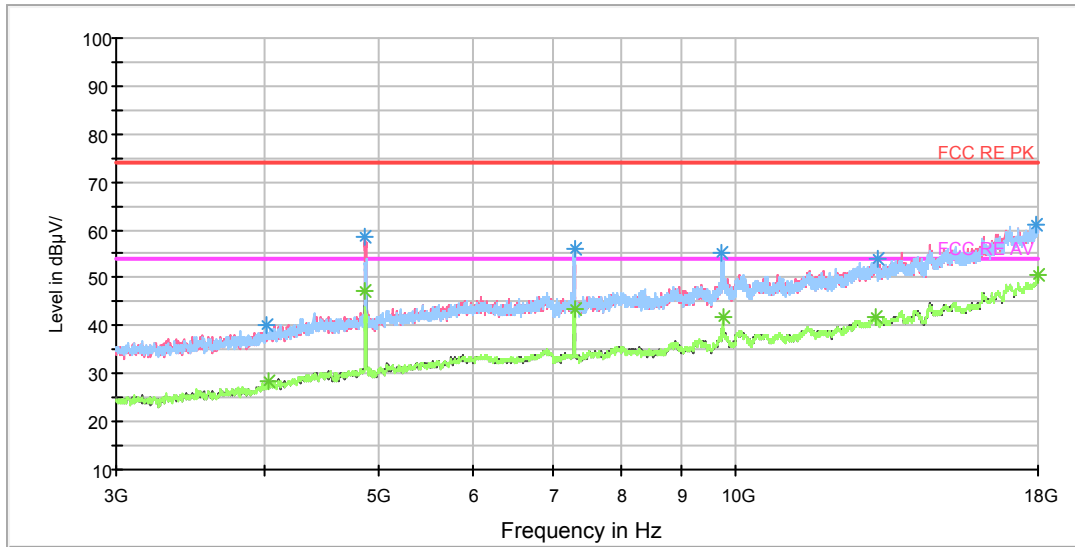

Radiates Emission from 3GHz to 18GHz

Frequency (MHz)	Peak (dBuV/m)	Height (cm)	Polarization	Azimuth (deg)	Reading value (dBuV/m)	Correct Factor (dB)	Margin (dB)	Limit (dBuV/m)
4023.750000	39.9	102.0	H	16.0	40.5	0.6	34.1	74
4867.500000	58.5	102.0	V	173.0	61.5	3.0	15.5	74
7312.500000	55.9	102.0	H	155.0	64.5	8.6	18.1	74
9735.000000	55.3	102.0	H	247.0	66.8	11.5	18.7	74
13160.625000	53.7	102.0	V	0.0	69.1	15.4	20.3	74
17917.500000	61.2	102.0	V	234.0	85.6	24.4	12.8	74

Remark: 1. Correction Factor = Antenna factor+ Insertion loss (cable loss + amplifier gain)

Frequency (MHz)	Average (dBuV/m)	Height (cm)	Polarization	Azimuth (deg)	Reading value (dBuV/m)	Correct Factor (dB)	Margin (dB)	Limit (dBuV/m)
4036.875000	28.6	102.0	H	62.0	29.2	0.6	25.4	54
4871.250000	47.2	102.0	V	173.0	50.2	3.0	6.8	54
7306.875000	43.5	102.0	H	155.0	52.1	8.6	10.5	54
9748.125000	41.8	102.0	H	247.0	53.4	11.6	12.2	54
13121.250000	41.9	102.0	V	203.0	57.8	15.9	12.1	54
17994.375000	50.5	102.0	H	78.0	75.8	25.3	3.5	54

Remark: 1. Correction Factor = Antenna factor+ Insertion loss (cable loss + amplifier gain)

RE 18-26.5GHz PK+AV

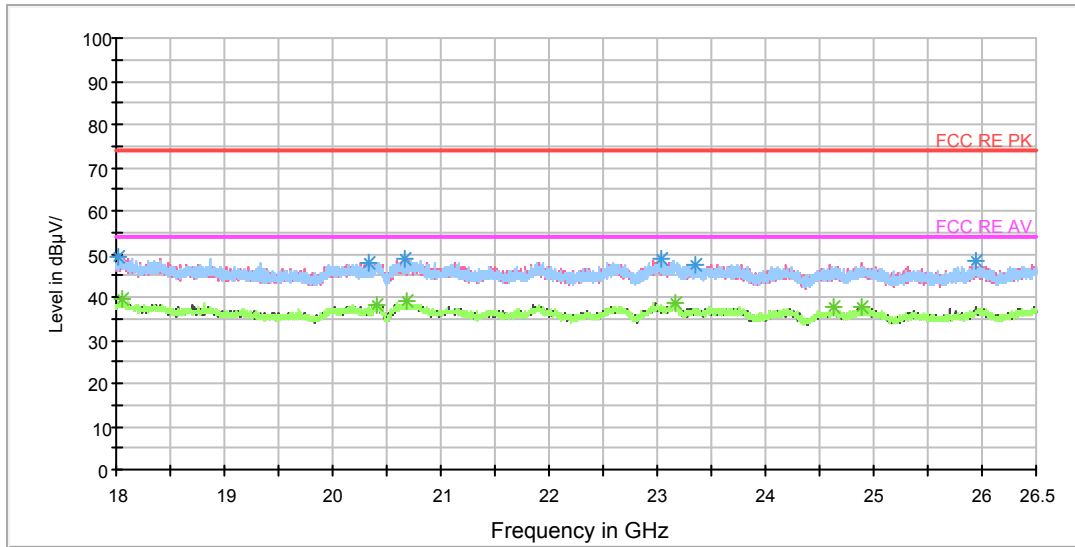

Radiates Emission from 18GHz to 26.5GHz

Frequency (MHz)	Peak (dBuV/m)	Height (cm)	Polarization	Azimuth (deg)	Reading value (dBuV/m)	Correct Factor (dB)	Margin (dB)	Limit (dBuV/m)
18024.437500	49.3	101.0	V	352.0	51.2	-1.9	24.7	74
20334.312500	48.1	101.0	V	263.0	54.1	-6.0	25.9	74
20661.562500	48.7	101.0	V	288.0	55.3	-6.6	25.3	74
23032.000000	48.6	101.0	H	277.0	54.7	-6.1	25.4	74
23348.625000	47.6	101.0	H	101.0	53.5	-5.9	26.4	74
25935.812500	48.3	101.0	H	14.0	53.7	-5.4	25.7	74

Remark: 1. Correction Factor = Antenna factor+ Insertion loss (cable loss + amplifier gain)

Frequency (MHz)	Average (dBuV/m)	Height (cm)	Polarization	Azimuth (deg)	Reading value (dBuV/m)	Correct Factor (dB)	Margin (dB)	Limit (dBuV/m)
18057.375000	39.5	101.0	H	137.0	41.5	-2.0	14.5	54
20414.000000	38.3	101.0	V	162.0	44.4	-6.1	15.7	54
20683.875000	39.1	101.0	V	339.0	45.7	-6.6	14.9	54
23164.812500	38.7	101.0	H	27.0	44.8	-6.1	15.3	54
24638.500000	37.5	101.0	H	2.0	43.5	-6.0	16.5	54
24893.500000	37.7	101.0	H	52.0	43.6	-5.9	16.3	54

Remark: 1. Correction Factor = Antenna factor+ Insertion loss (cable loss + amplifier gain)



802.11g CH11

RE 0.03-1GHz QP Class B

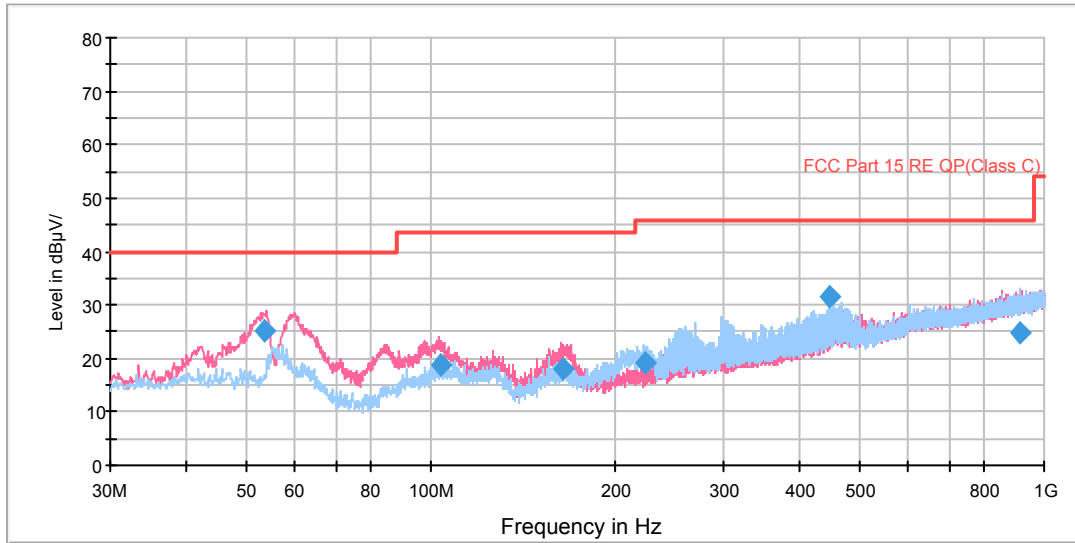

Radiates Emission from 30MHz to 1GHz

Frequency (MHz)	Quasi-Peak (dBuV/m)	Height (cm)	Polarization	Azimuth (deg)	Reading value (dBuV/m)	Correct Factor (dB)	Margin (dB)	Limit (dBuV/m)
53.607500	25.1	100.0	V	0.0	37.9	12.8	14.9	40.0
103.475000	18.8	100.0	V	266.0	31.7	12.9	21.2	40.0
163.853750	18.1	100.0	V	216.0	28.0	9.9	21.9	40.0
222.947500	19.1	125.0	H	344.0	32.1	13.0	20.9	40.0
445.483750	31.6	100.0	H	137.0	50.5	18.9	15.4	47.0
916.222500	24.7	114.0	H	0.0	50.5	25.8	22.3	47.0

- Remark: 1. Quasi-Peak = Reading value + Correction factor
 2. Correction Factor = Antenna factor+ Insertion loss (cable loss+amplifier gain)
 3. Margin = Limit – Quasi-Peak

RE 1G-3GHz PK+AV

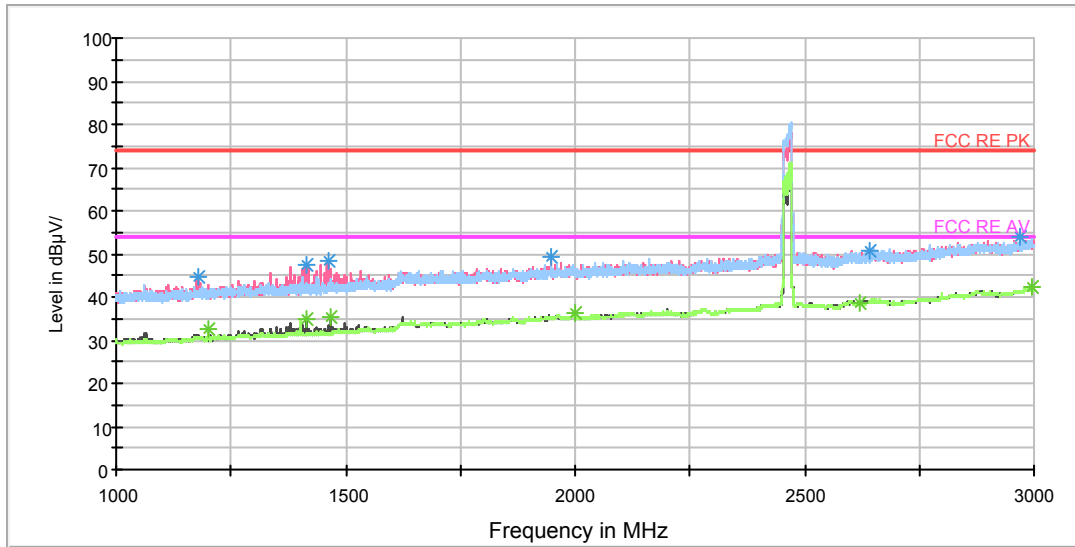

Note: The signal beyond the limit is carrier.

Radiates Emission from 1GHz to 3GHz

Frequency (MHz)	Peak (dBuV/m)	Height (cm)	Polarization	Azimuth (deg)	Reading value (dBuV/m)	Correct Factor (dB)	Margin (dB)	Limit (dBuV/m)
1179.500000	44.6	101.0	V	238.0	52.6	-8.0	29.4	74
1414.750000	47.3	101.0	V	283.0	54.3	-7.0	26.7	74
1460.750000	48.2	101.0	V	227.0	55.1	-6.9	25.8	74
1949.000000	49.2	101.0	V	144.0	52.7	-3.5	24.8	74
2641.000000	50.8	101.0	V	156.0	51.0	0.2	23.2	74
2969.250000	54.0	101.0	H	0.0	56.2	2.2	20.0	74

Remark: 1. Correction Factor = Antenna factor+ Insertion loss (cable loss + amplifier gain)

Frequency (MHz)	Average (dBuV/m)	Height (cm)	Polarization	Azimuth (deg)	Reading value (dBuV/m)	Correct Factor (dB)	Margin (dB)	Limit (dBuV/m)
1199.750000	32.6	101.0	H	3.0	40.8	-8.2	21.4	54
1416.750000	34.8	101.0	V	227.0	41.8	-7.0	19.2	54
1465.750000	35.4	101.0	V	227.0	42.2	-6.8	18.6	54
2000.000000	36.3	101.0	H	3.0	39.7	-3.4	17.7	54
2620.500000	38.8	101.0	H	38.0	38.9	-0.1	15.2	54
2997.000000	42.4	101.0	H	0.0	44.7	2.3	11.6	54

Remark: 1. Correction Factor = Antenna factor+ Insertion loss (cable loss + amplifier gain)



RE 3-18GHz PK+AV

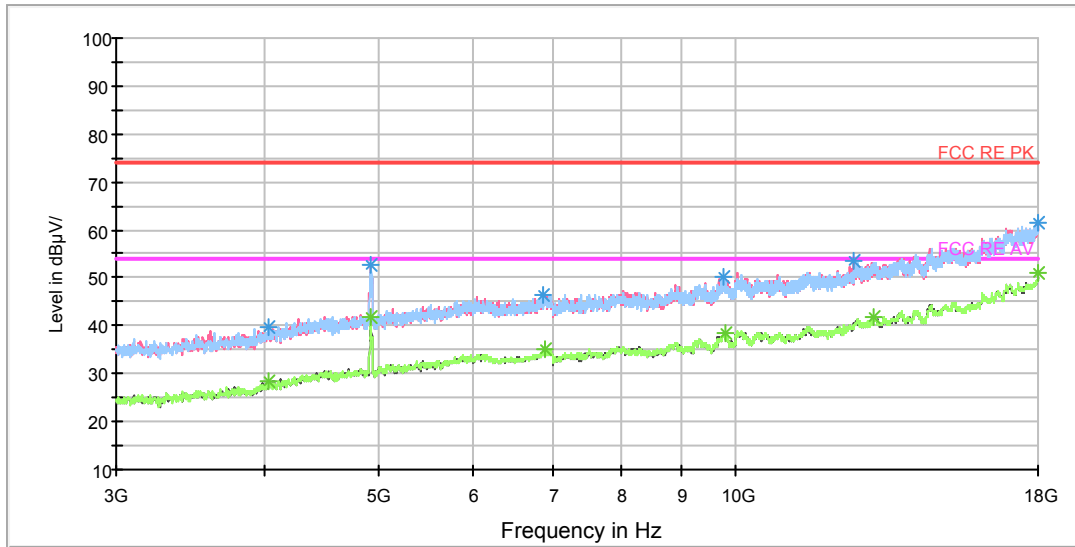

Radiates Emission from 3GHz to 18GHz

Frequency (MHz)	Peak (dBuV/m)	Height (cm)	Polarization	Azimuth (deg)	Reading value (dBuV/m)	Correct Factor (dB)	Margin (dB)	Limit (dBuV/m)
4036.875000	39.5	102.0	H	0.0	40.1	0.6	34.5	74
4918.125000	52.8	102.0	V	209.0	55.9	3.1	21.2	74
6890.625000	46.5	102.0	H	187.0	53.4	6.9	27.5	74
9770.625000	50.4	102.0	H	0.0	62.3	11.9	23.6	74
12594.375000	53.3	102.0	V	300.0	68.0	14.7	20.7	74
17998.125000	61.5	102.0	H	0.0	86.9	25.4	12.5	74

Remark: 1. Correction Factor = Antenna factor+ Insertion loss (cable loss + amplifier gain)

Frequency (MHz)	Average (dBuV/m)	Height (cm)	Polarization	Azimuth (deg)	Reading value (dBuV/m)	Correct Factor (dB)	Margin (dB)	Limit (dBuV/m)
4035.000000	28.3	102.0	V	179.0	28.9	0.6	25.7	54
4920.000000	41.9	102.0	V	164.0	45.0	3.1	12.1	54
6916.875000	35.3	102.0	V	0.0	42.2	6.9	18.7	54
9810.000000	38.4	102.0	V	0.0	50.6	12.2	15.6	54
13093.125000	41.8	102.0	V	316.0	58.0	16.2	12.2	54
18000.000000	50.8	102.0	H	187.0	76.2	25.4	3.2	54

Remark: 1. Correction Factor = Antenna factor+ Insertion loss (cable loss + amplifier gain)

RE 18-26.5GHz PK+AV

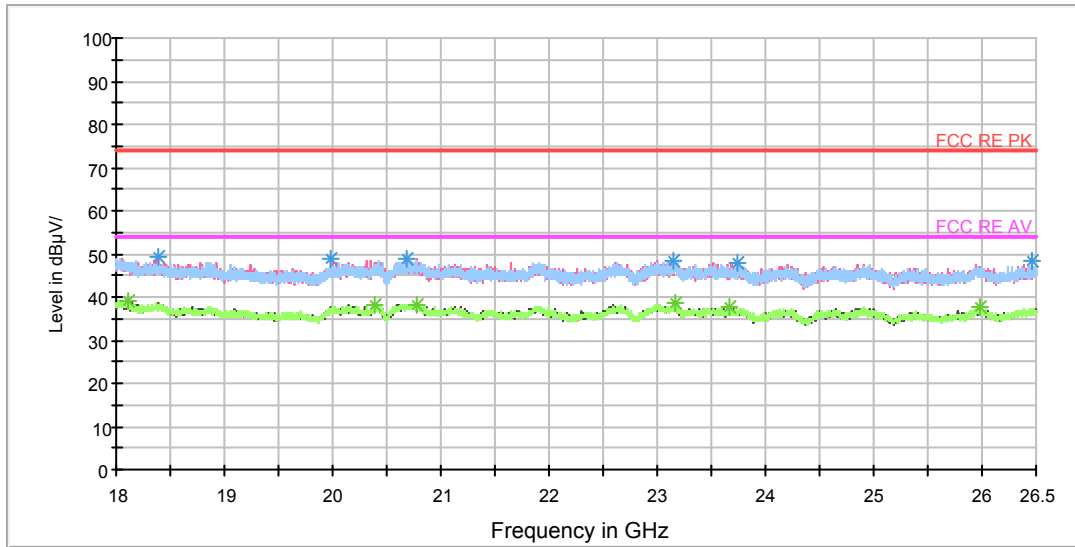

Radiates Emission from 18GHz to 26.5GHz

Frequency (MHz)	Peak (dBuV/m)	Height (cm)	Polarization	Azimuth (deg)	Reading value (dBuV/m)	Correct Factor (dB)	Margin (dB)	Limit (dBuV/m)
18381.437500	49.1	101.0	V	275.0	52.5	-3.4	24.9	74
19986.875000	48.7	101.0	H	0.0	54.4	-5.7	25.3	74
20692.375000	49.0	101.0	V	338.0	55.7	-6.7	25.0	74
23153.125000	48.3	101.0	H	265.0	54.4	-6.1	25.7	74
23747.062500	48.0	101.0	H	21.0	53.9	-5.9	26.0	74
26466.000000	48.2	101.0	V	0.0	53.6	-5.4	25.8	74

Remark: 1. Correction Factor = Antenna factor+ Insertion loss (cable loss + amplifier gain)

Frequency (MHz)	Average (dBuV/m)	Height (cm)	Polarization	Azimuth (deg)	Reading value (dBuV/m)	Correct Factor (dB)	Margin (dB)	Limit (dBuV/m)
18103.062500	39.1	101.0	H	47.0	41.3	-2.2	14.9	54
20384.250000	38.1	101.0	V	238.0	44.2	-6.1	15.9	54
20779.500000	38.3	101.0	V	263.0	45.2	-6.9	15.7	54
23161.625000	38.5	101.0	H	0.0	44.6	-6.1	15.5	54
23668.437500	37.6	101.0	H	0.0	43.5	-5.9	16.4	54
25978.312500	37.7	101.0	V	0.0	43.1	-5.4	16.3	54

Remark: 1. Correction Factor = Antenna factor+ Insertion loss (cable loss + amplifier gain)

MIMO
802.11n (HT20) CH1

FCC RE 0.03-1GHz QP Class C

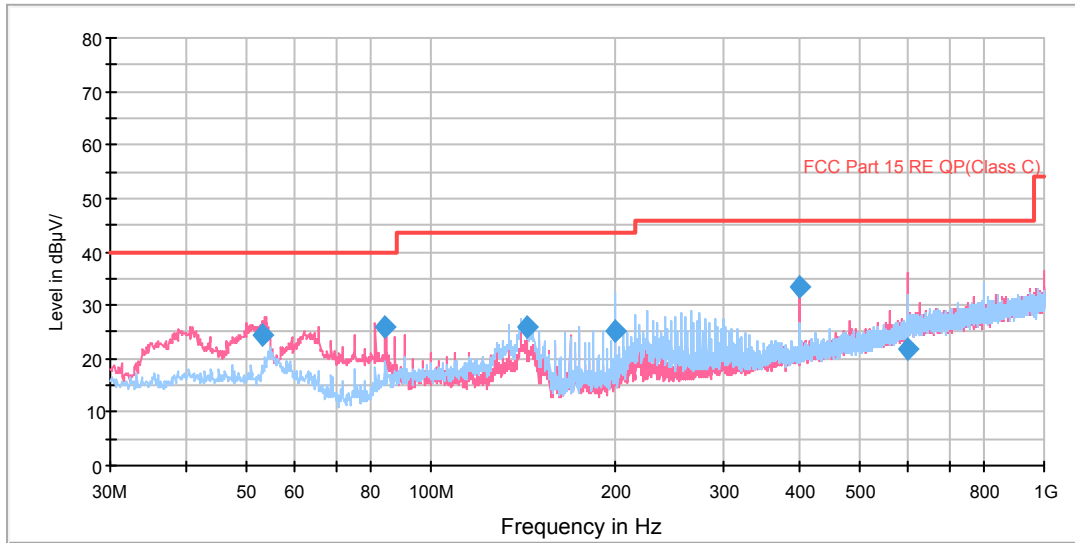

Radiates Emission from 30MHz to 1GHz

Frequency (MHz)	Quasi-Peak (dBuV/m)	Height (cm)	Polarization	Azimuth (deg)	Reading value (dBuV/m)	Correct Factor (dB)	Margin (dB)	Limit (dBuV/m)
53.123750	24.5	100.0	V	223.0	37.3	12.8	15.5	40.0
84.360000	25.8	125.0	V	335.0	35.8	10.0	14.2	40.0
143.732500	25.9	125.0	H	29.0	34.8	8.9	17.6	43.5
199.991250	25.3	125.0	H	137.0	37.3	12.0	18.2	43.5
399.975000	33.5	125.0	V	68.0	51.4	17.9	12.5	46.0
600.116250	21.7	100.0	V	222.0	43.9	22.2	24.3	46.0

- Remark: 1. Quasi-Peak = Reading value + Correction factor**
2. Correction Factor = Antenna factor+ Insertion loss (cable loss+amplifier gain)
3. Margin = Limit – Quasi-Peak

RE 1G-3GHz PK+AV

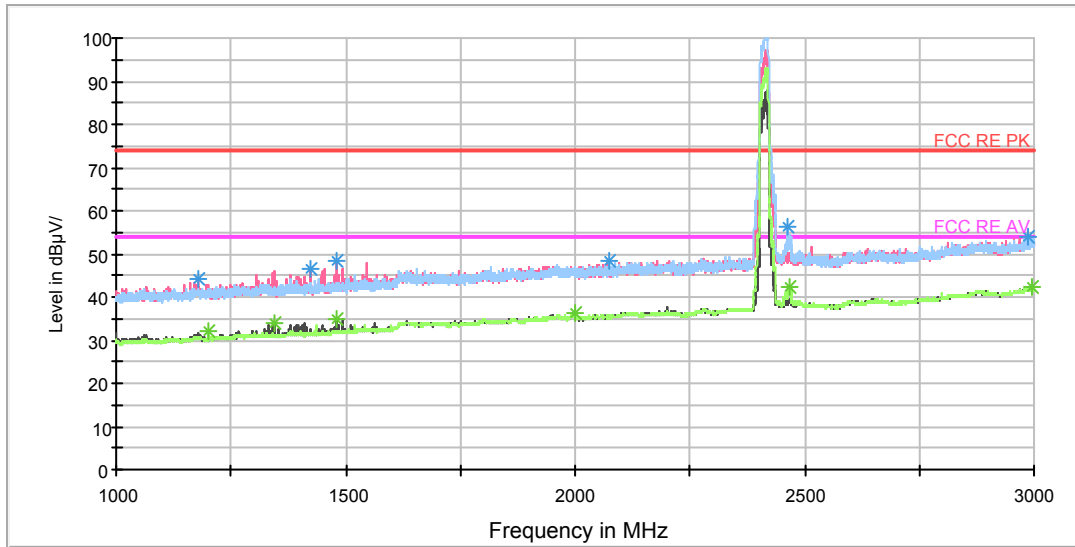

Note: The signal beyond the limit is carrier.
Radiates Emission from 1GHz to 3GHz

Frequency (MHz)	Peak (dBuV/m)	Height (cm)	Polarization	Azimuth (deg)	Reading value (dBuV/m)	Correct Factor (dB)	Margin (dB)	Limit (dBuV/m)
1178.250000	44.2	101.0	V	194.0	52.2	-8.0	29.8	74
1422.500000	46.3	101.0	V	136.0	53.2	-6.9	27.7	74
1479.750000	48.3	101.0	V	218.0	54.8	-6.5	25.7	74
2072.500000	48.3	101.0	H	157.0	51.4	-3.1	25.7	74
2462.500000	56.2	101.0	H	146.0	56.7	-0.5	17.8	74
2988.250000	53.8	101.0	H	76.0	56.0	2.2	20.2	74

Remark: 1. Correction Factor = Antenna factor+ Insertion loss (cable loss + amplifier gain)

Frequency (MHz)	Average (dBuV/m)	Height (cm)	Polarization	Azimuth (deg)	Reading value (dBuV/m)	Correct Factor (dB)	Margin (dB)	Limit (dBuV/m)
1200.000000	32.0	101.0	H	8.0	40.2	-8.2	22.0	54
1346.000000	34.1	101.0	V	287.0	41.6	-7.5	19.9	54
1479.750000	34.8	101.0	V	218.0	41.3	-6.5	19.2	54
2000.000000	36.1	101.0	H	0.0	39.5	-3.4	17.9	54
2467.750000	42.5	101.0	H	192.0	42.9	-0.4	11.5	54
2995.250000	42.3	101.0	V	113.0	44.6	2.3	11.7	54

Remark: 1. Correction Factor = Antenna factor+ Insertion loss (cable loss + amplifier gain)

RE 3-18GHz PK+AV

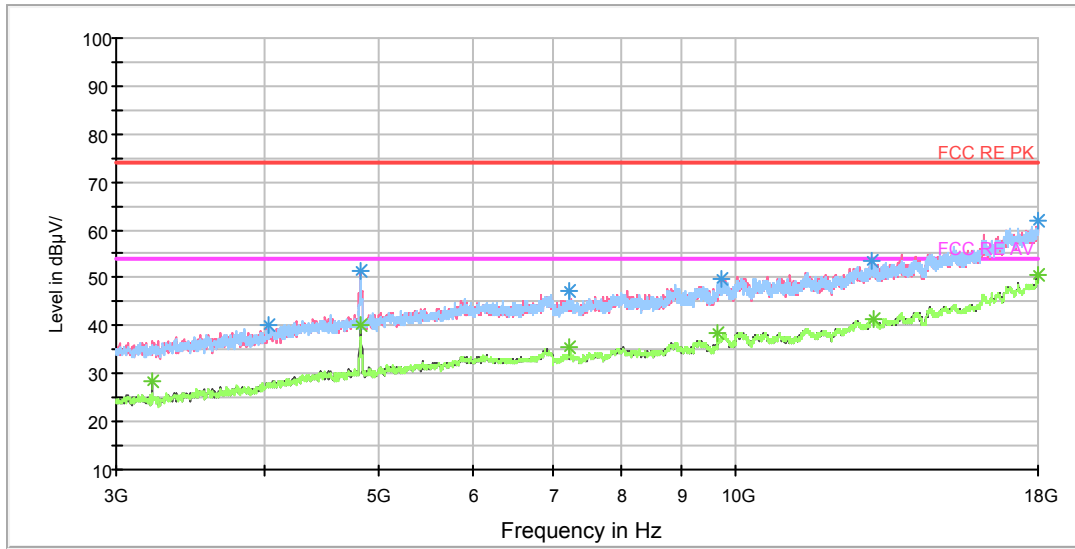

Radiates Emission from 3GHz to 18GHz

Frequency (MHz)	Peak (dBuV/m)	Height (cm)	Polarization	Azimuth (deg)	Reading value (dBuV/m)	Correct Factor (dB)	Margin (dB)	Limit (dBuV/m)
4036.875000	40.3	101.0	H	0.0	40.9	0.6	33.7	74
4824.375000	51.4	101.0	V	189.0	54.2	2.8	22.6	74
7237.500000	47.2	101.0	H	3.0	55.9	8.7	26.8	74
9721.875000	49.7	101.0	V	355.0	61.0	11.3	24.3	74
13003.125000	53.6	101.0	V	325.0	69.8	16.2	20.4	74
17979.375000	61.8	101.0	H	217.0	87.0	25.2	12.2	74

Remark: 1. Correction Factor = Antenna factor+ Insertion loss (cable loss + amplifier gain)

Frequency (MHz)	Average (dBuV/m)	Height (cm)	Polarization	Azimuth (deg)	Reading value (dBuV/m)	Correct Factor (dB)	Margin (dB)	Limit (dBuV/m)
3215.625000	28.4	101.0	V	0.0	30.1	-1.7	25.6	54
4820.625000	40.2	101.0	V	189.0	42.9	2.7	13.8	54
7239.375000	35.7	101.0	H	296.0	44.4	8.7	18.3	54
9648.750000	38.5	101.0	H	201.0	49.0	10.5	15.5	54
13063.125000	41.6	101.0	H	94.0	57.8	16.2	12.4	54
18000.000000	50.5	101.0	H	109.0	75.9	25.4	3.5	54

Remark: 1. Correction Factor = Antenna factor+ Insertion loss (cable loss + amplifier gain)

RE 18-26.5GHz PK+AV

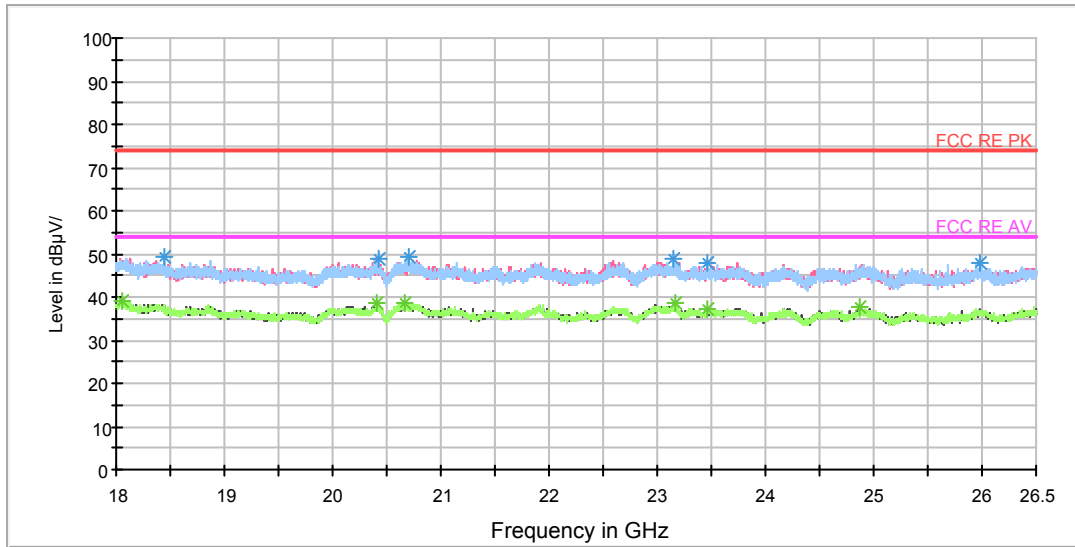

Radiates Emission from 18GHz to 26.5GHz

Frequency (MHz)	Peak (dBuV/m)	Height (cm)	Polarization	Azimuth (deg)	Reading value (dBuV/m)	Correct Factor (dB)	Margin (dB)	Limit (dBuV/m)
18439.875000	49.5	101.0	H	212.0	53.2	-3.7	24.5	74
20426.750000	48.9	101.0	V	152.0	55.0	-6.1	25.1	74
20698.750000	49.3	101.0	V	101.0	56.0	-6.7	24.7	74
23151.000000	48.7	101.0	H	2.0	54.8	-6.1	25.3	74
23458.062500	48.1	101.0	H	2.0	54.0	-5.9	25.9	74
25977.250000	47.8	101.0	H	0.0	53.2	-5.4	26.2	74

Remark: 1. Correction Factor = Antenna factor+ Insertion loss (cable loss + amplifier gain)

Frequency (MHz)	Average (dBuV/m)	Height (cm)	Polarization	Azimuth (deg)	Reading value (dBuV/m)	Correct Factor (dB)	Margin (dB)	Limit (dBuV/m)
18062.687500	39.1	101.0	H	76.0	41.2	-2.1	14.9	54
20400.187500	38.6	101.0	H	250.0	44.7	-6.1	15.4	54
20672.187500	38.6	101.0	H	237.0	45.2	-6.6	15.4	54
23165.875000	38.7	101.0	H	100.0	44.8	-6.1	15.3	54
23454.875000	37.4	101.0	V	263.0	43.3	-5.9	16.6	54
24873.312500	37.8	101.0	V	30.0	43.7	-5.9	16.2	54

Remark: 1. Correction Factor = Antenna factor+ Insertion loss (cable loss + amplifier gain)

802.11n (HT20) CH6

FCC RE 0.03-1GHz QP Class C

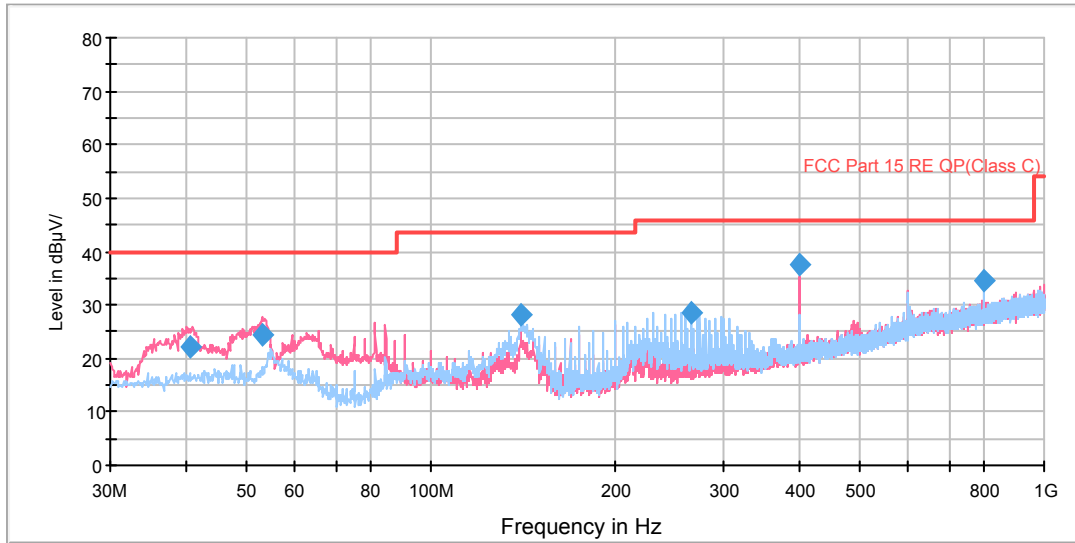

Radiates Emission from 30MHz to 1GHz

Frequency (MHz)	Quasi-Peak (dBuV/m)	Height (cm)	Polarization	Azimuth (deg)	Reading value (dBuV/m)	Correct Factor (dB)	Margin (dB)	Limit (dBuV/m)
40.663750	22.0	100.0	V	254.0	35.2	13.2	18.0	40.0
53.118750	24.4	100.0	V	220.0	37.2	12.8	15.6	40.0
140.620000	28.0	125.0	H	177.0	36.9	8.9	15.5	43.5
265.628750	28.6	100.0	H	17.0	43.1	14.5	17.4	46.0
400.015000	37.5	100.0	V	266.0	55.4	17.9	8.5	46.0
800.018750	34.7	100.0	H	194.0	59.1	24.4	11.3	46.0

- Remark:**
1. Quasi-Peak = Reading value + Correction factor
 2. Correction Factor = Antenna factor+ Insertion loss (cable loss+amplifier gain)
 3. Margin = Limit – Quasi-Peak

RE 1G-3GHz PK+AV

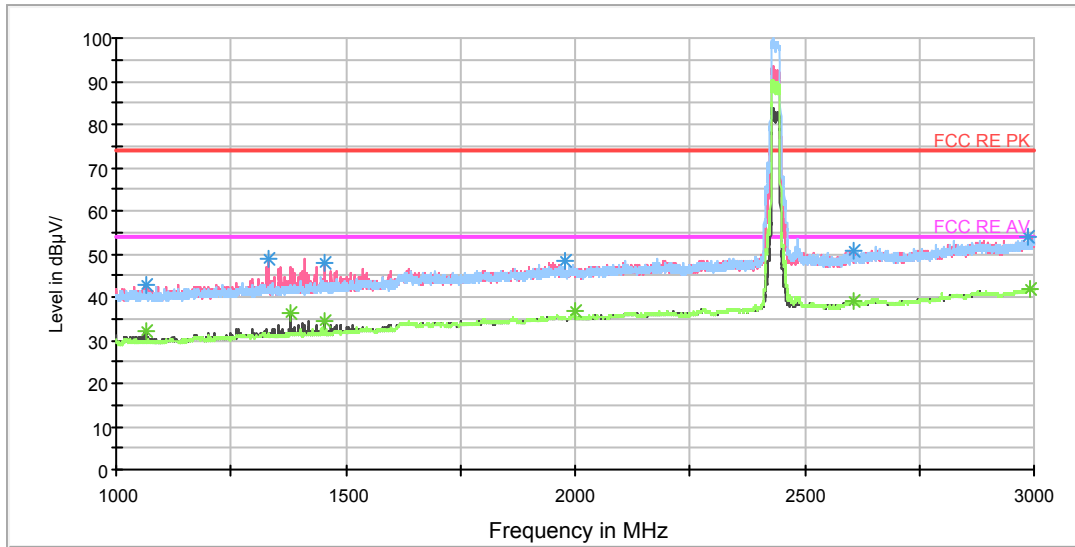

Note: The signal beyond the limit is carrier.
Radiates Emission from 1GHz to 3GHz

Frequency (MHz)	Peak (dBuV/m)	Height (cm)	Polarization	Azimuth (deg)	Reading value (dBuV/m)	Correct Factor (dB)	Margin (dB)	Limit (dBuV/m)
1064.000000	42.8	101.0	V	202.0	51.7	-8.9	31.2	74
1332.750000	49.1	101.0	V	276.0	56.5	-7.4	24.9	74
1454.250000	48.1	101.0	V	239.0	54.8	-6.7	25.9	74
1979.000000	48.5	101.0	V	0.0	52.2	-3.7	25.5	74
2605.500000	50.8	101.0	V	294.0	51.1	0.3	23.2	74
2989.000000	53.8	101.0	H	140.0	56.0	2.2	20.2	74

Remark: 1. Correction Factor = Antenna factor+ Insertion loss (cable loss + amplifier gain)

Frequency (MHz)	Average (dBuV/m)	Height (cm)	Polarization	Azimuth (deg)	Reading value (dBuV/m)	Correct Factor (dB)	Margin (dB)	Limit (dBuV/m)
1066.000000	32.2	101.0	V	202.0	41.1	-8.9	21.8	54
1380.250000	36.4	101.0	V	276.0	43.4	-7.0	17.6	54
1454.250000	34.6	101.0	V	239.0	41.3	-6.7	19.4	54
2000.000000	36.9	101.0	H	0.0	40.3	-3.4	17.1	54
2605.500000	39.1	101.0	V	294.0	39.4	0.3	14.9	54
2993.250000	42.0	101.0	H	44.0	44.2	2.2	12.0	54

Remark: 1. Correction Factor = Antenna factor+ Insertion loss (cable loss + amplifier gain)

RE 3-18GHz PK+AV

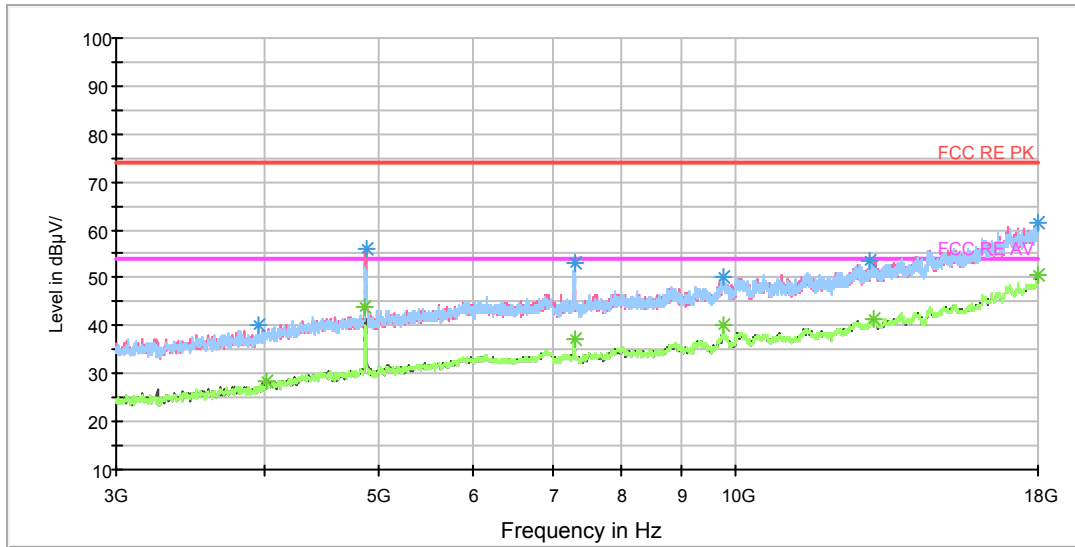

Radiates Emission from 3GHz to 18GHz

Frequency (MHz)	Peak (dBuV/m)	Height (cm)	Polarization	Azimuth (deg)	Reading value (dBuV/m)	Correct Factor (dB)	Margin (dB)	Limit (dBuV/m)
3952.500000	40.1	101.0	H	0.0	40.3	0.2	33.9	74
4873.125000	55.9	101.0	V	188.0	58.9	3.0	18.1	74
7314.375000	53.3	101.0	H	199.0	61.9	8.6	20.7	74
9757.500000	50.0	101.0	V	250.0	61.7	11.7	24.0	74
12988.125000	53.4	101.0	H	48.0	69.6	16.2	20.6	74
17970.000000	61.5	101.0	H	77.0	86.6	25.1	12.5	74

Remark: 1. Correction Factor = Antenna factor+ Insertion loss (cable loss + amplifier gain)

Frequency (MHz)	Average (dBuV/m)	Height (cm)	Polarization	Azimuth (deg)	Reading value (dBuV/m)	Correct Factor (dB)	Margin (dB)	Limit (dBuV/m)
4023.750000	28.4	101.0	H	0.0	29.0	0.6	25.6	54
4869.375000	43.8	101.0	V	188.0	46.8	3.0	10.2	54
7306.875000	37.1	101.0	H	139.0	45.7	8.6	16.9	54
9748.125000	40.1	101.0	H	231.0	51.7	11.6	13.9	54
13061.250000	41.5	101.0	H	199.0	57.7	16.2	12.5	54
18000.000000	50.6	101.0	H	0.0	76.0	25.4	3.4	54

Remark: 1. Correction Factor = Antenna factor+ Insertion loss (cable loss + amplifier gain)



RE 18-26.5GHz PK+AV

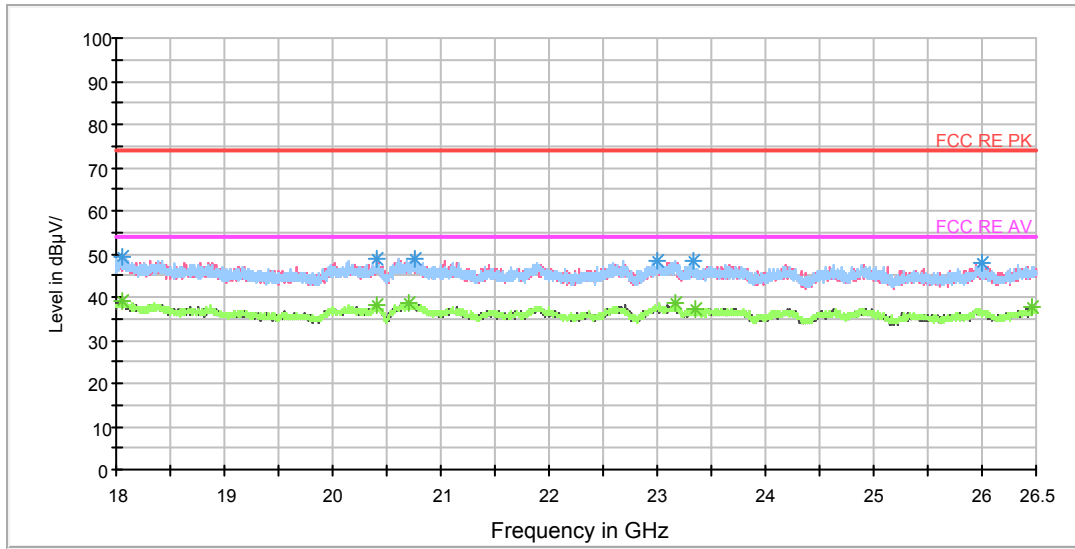

Radiates Emission from 18GHz to 26.5GHz

Frequency (MHz)	Peak (dBuV/m)	Height (cm)	Polarization	Azimuth (deg)	Reading value (dBuV/m)	Correct Factor (dB)	Margin (dB)	Limit (dBuV/m)
18057.375000	49.2	101.0	V	237.0	51.2	-2.0	24.8	74
20403.375000	48.7	101.0	V	138.0	54.8	-6.1	25.3	74
20754.000000	49.1	101.0	V	237.0	55.9	-6.8	24.9	74
22992.687500	48.5	101.0	V	0.0	54.7	-6.2	25.5	74
23336.937500	48.1	101.0	H	51.0	54.1	-6.0	25.9	74
26002.750000	47.7	101.0	H	239.0	53.1	-5.4	26.3	74

Remark: 1. Correction Factor = Antenna factor+ Insertion loss (cable loss + amplifier gain)

Frequency (MHz)	Average (dBuV/m)	Height (cm)	Polarization	Azimuth (deg)	Reading value (dBuV/m)	Correct Factor (dB)	Margin (dB)	Limit (dBuV/m)
18064.812500	39.1	101.0	H	25.0	41.2	-2.1	14.9	54
20404.437500	38.2	101.0	V	275.0	44.3	-6.1	15.8	54
20703.000000	38.7	101.0	V	349.0	45.4	-6.7	15.3	54
23170.125000	38.4	101.0	V	325.0	44.5	-6.1	15.6	54
23345.437500	37.3	101.0	V	349.0	43.2	-5.9	16.7	54
26466.000000	37.6	101.0	V	300.0	43.0	-5.4	16.4	54

Remark: 1. Correction Factor = Antenna factor+ Insertion loss (cable loss + amplifier gain)

802.11n (HT20) CH11

FCC RE 0.03-1GHz QP Class C

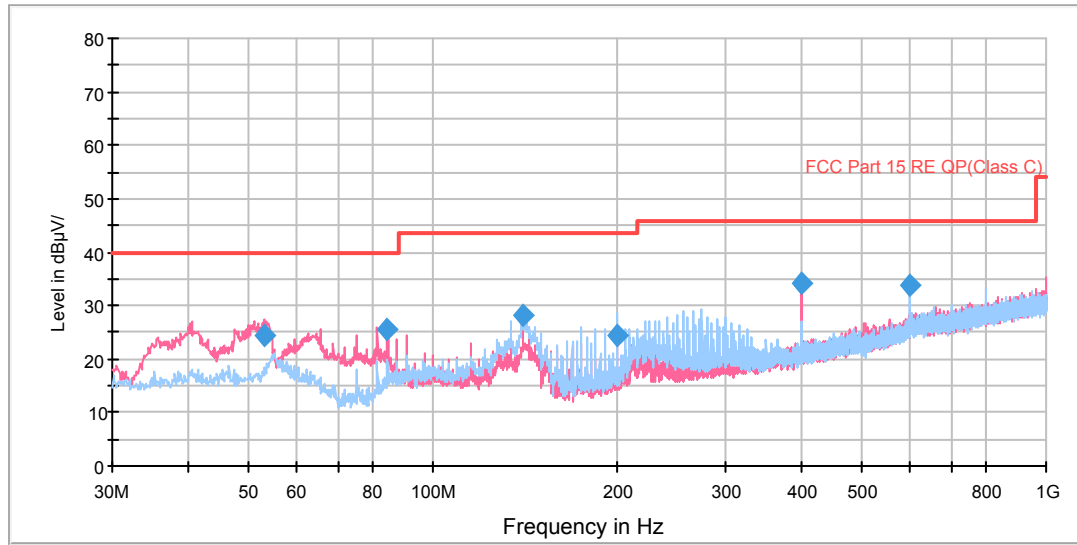

Radiates Emission from 30MHz to 1GHz

Frequency (MHz)	Quasi-Peak (dBuV/m)	Height (cm)	Polarization	Azimuth (deg)	Reading value (dBuV/m)	Correct Factor (dB)	Margin (dB)	Limit (dBuV/m)
53.117500	24.4	100.0	V	198.0	37.2	12.8	15.6	40.0
84.360000	25.4	114.0	V	349.0	35.4	10.0	14.6	40.0
140.620000	28.2	125.0	H	175.0	37.1	8.9	15.3	43.5
199.952500	24.5	125.0	H	147.0	36.5	12.0	19.0	43.5
400.015000	34.3	100.0	V	22.0	52.2	17.9	11.7	46.0
599.997500	33.8	100.0	H	205.0	56.0	22.2	12.2	46.0

- Remark: 1. Quasi-Peak = Reading value + Correction factor
 2. Correction Factor = Antenna factor+ Insertion loss (cable loss+amplifier gain)
 3. Margin = Limit – Quasi-Peak

RE 1G-3GHz PK+AV

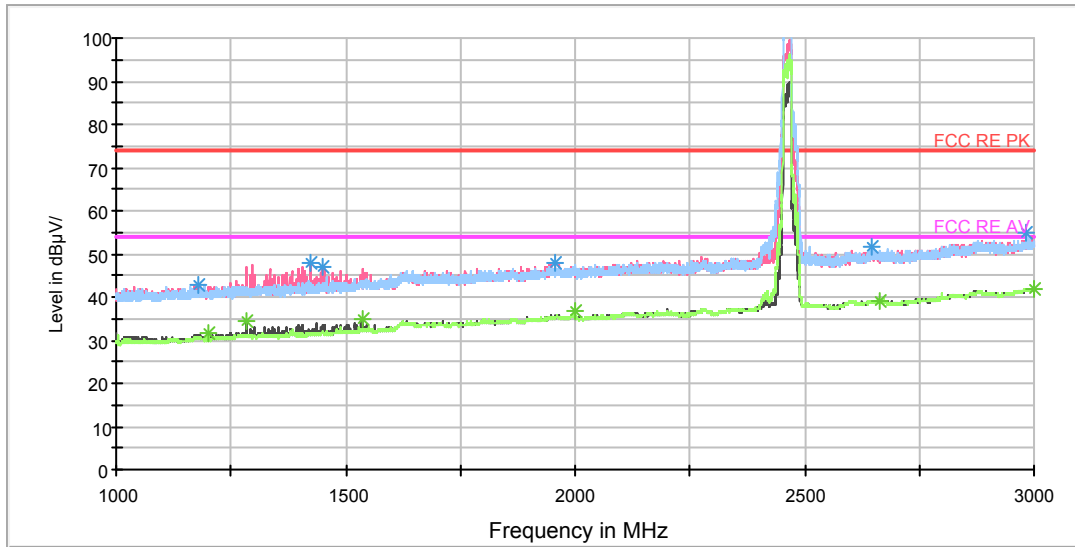

Note: The signal beyond the limit is carrier.
Radiates Emission from 1GHz to 3GHz

Frequency (MHz)	Peak (dBuV/m)	Height (cm)	Polarization	Azimuth (deg)	Reading value (dBuV/m)	Correct Factor (dB)	Margin (dB)	Limit (dBuV/m)
1180.000000	42.8	101.0	V	212.0	50.8	-8.0	31.2	74
1425.500000	47.9	101.0	V	295.0	54.8	-6.9	26.1	74
1449.000000	46.8	101.0	V	276.0	53.4	-6.6	27.2	74
1955.000000	47.8	101.0	V	138.0	51.3	-3.5	26.2	74
2646.750000	51.4	101.0	H	65.0	51.7	0.3	22.6	74
2983.000000	55.0	101.0	H	0.0	57.2	2.2	19.0	74

Remark: 1. Correction Factor = Antenna factor+ Insertion loss (cable loss + amplifier gain)

Frequency (MHz)	Average (dBuV/m)	Height (cm)	Polarization	Azimuth (deg)	Reading value (dBuV/m)	Correct Factor (dB)	Margin (dB)	Limit (dBuV/m)
1200.000000	31.6	101.0	V	240.0	39.8	-8.2	22.4	54
1284.500000	34.5	101.0	V	82.0	42.2	-7.7	19.5	54
1535.000000	34.7	101.0	V	221.0	41.1	-6.4	19.3	54
1999.750000	36.5	101.0	H	10.0	39.9	-3.4	17.5	54
2662.250000	39.2	101.0	V	0.0	39.5	0.3	14.8	54
2999.750000	42.1	101.0	V	221.0	44.4	2.3	11.9	54

Remark: 1. Correction Factor = Antenna factor+ Insertion loss (cable loss + amplifier gain)

RE 3-18GHz PK+AV

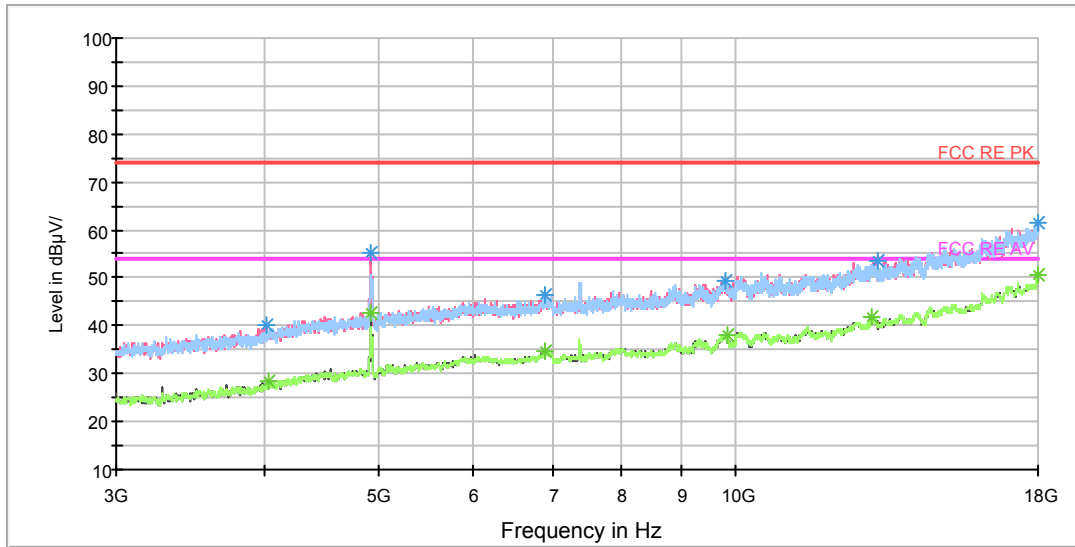

Radiates Emission from 3GHz to 18GHz

Frequency (MHz)	Peak (dBuV/m)	Height (cm)	Polarization	Azimuth (deg)	Reading value (dBuV/m)	Correct Factor (dB)	Margin (dB)	Limit (dBuV/m)
4021.875000	40.0	101.0	V	159.0	40.5	0.5	34.0	74
4920.000000	55.3	101.0	V	174.0	58.4	3.1	18.7	74
6898.125000	46.2	101.0	V	235.0	53.2	7.0	27.8	74
9785.625000	49.5	101.0	H	30.0	61.6	12.1	24.5	74
13175.625000	53.4	101.0	H	30.0	68.7	15.3	20.6	74
17988.750000	61.4	101.0	H	77.0	86.7	25.3	12.6	74

Remark: 1. Correction Factor = Antenna factor+ Insertion loss (cable loss + amplifier gain)

Frequency (MHz)	Average (dBuV/m)	Height (cm)	Polarization	Azimuth (deg)	Reading value (dBuV/m)	Correct Factor (dB)	Margin (dB)	Limit (dBuV/m)
4036.875000	28.3	101.0	V	0.0	28.9	0.6	25.7	54
4920.000000	42.8	101.0	V	174.0	45.9	3.1	11.2	54
6911.250000	34.8	101.0	H	0.0	41.7	6.9	19.2	54
9847.500000	38.1	101.0	H	233.0	49.9	11.8	15.9	54
13046.250000	41.6	101.0	H	15.0	57.8	16.2	12.4	54
17996.250000	50.5	101.0	H	30.0	75.9	25.4	3.5	54

Remark: 1. Correction Factor = Antenna factor+ Insertion loss (cable loss + amplifier gain)

RE 18-26.5GHz PK+AV

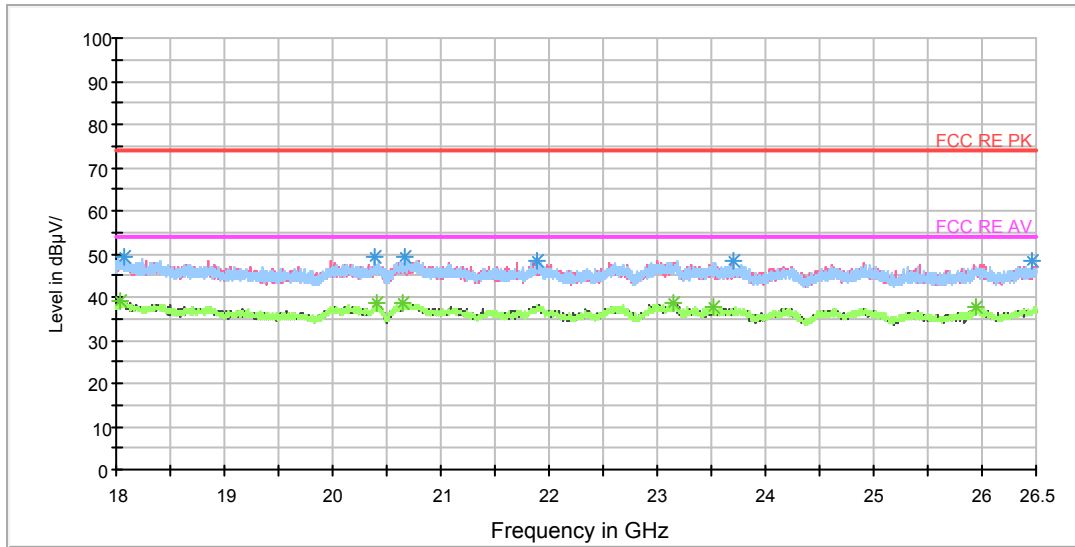

Radiates Emission from 18GHz to 26.5GHz

Frequency (MHz)	Peak (dBuV/m)	Height (cm)	Polarization	Azimuth (deg)	Reading value (dBuV/m)	Correct Factor (dB)	Margin (dB)	Limit (dBuV/m)
18066.937500	49.3	101.0	V	242.0	51.4	-2.1	24.7	74
20390.625000	49.3	101.0	H	124.0	55.4	-6.1	24.7	74
20662.625000	49.1	101.0	H	111.0	55.7	-6.6	24.9	74
21880.250000	48.3	101.0	V	175.0	56.3	-8.0	25.7	74
23709.875000	48.2	101.0	V	44.0	54.1	-5.9	25.8	74
26455.375000	48.2	101.0	H	200.0	53.6	-5.4	25.8	74

Remark: 1. Correction Factor = Antenna factor+ Insertion loss (cable loss + amplifier gain)

Frequency (MHz)	Average (dBuV/m)	Height (cm)	Polarization	Azimuth (deg)	Reading value (dBuV/m)	Correct Factor (dB)	Margin (dB)	Limit (dBuV/m)
18041.437500	39.2	101.0	V	352.0	41.2	-2.0	14.8	54
20409.750000	38.4	101.0	H	225.0	44.5	-6.1	15.6	54
20642.437500	38.5	101.0	V	217.0	45.0	-6.5	15.5	54
23151.000000	38.5	101.0	H	3.0	44.6	-6.1	15.5	54
23518.625000	37.6	101.0	V	0.0	43.5	-5.9	16.4	54
25943.250000	37.7	101.0	H	3.0	43.1	-5.4	16.3	54

Remark: 1. Correction Factor = Antenna factor+ Insertion loss (cable loss + amplifier gain)



802.11n (HT40) CH3

FCC RE 0.03-1GHz QP Class C

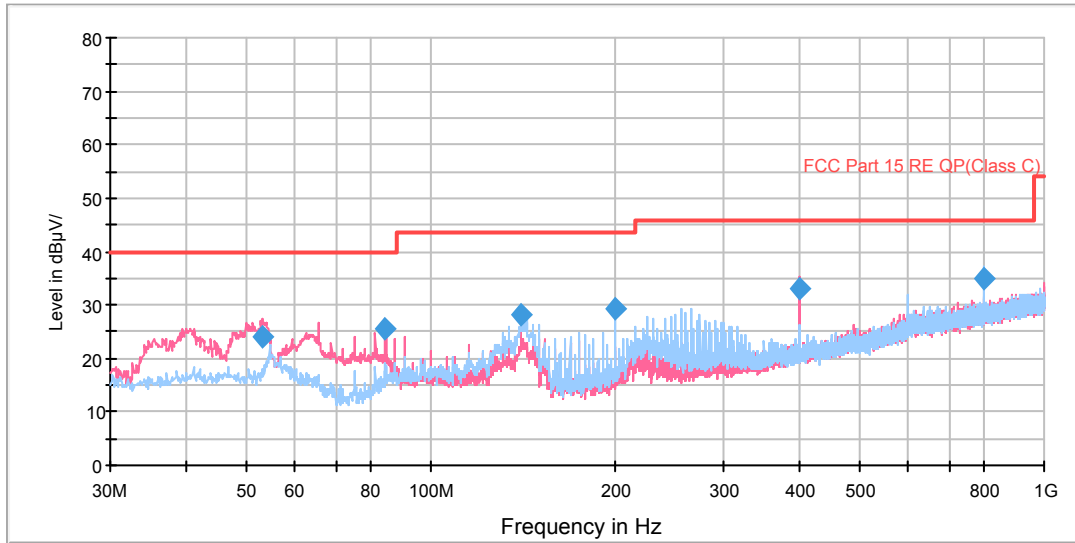

Radiates Emission from 30MHz to 1GHz

Frequency (MHz)	Quasi-Peak (dBuV/m)	Height (cm)	Polarization	Azimuth (deg)	Reading value (dBuV/m)	Correct Factor (dB)	Margin (dB)	Limit (dBuV/m)
53.118750	24.0	100.0	V	282.0	36.8	12.8	16.0	40.0
84.360000	25.7	125.0	V	338.0	35.7	10.0	14.3	40.0
140.620000	28.3	125.0	H	26.0	37.2	8.9	15.2	43.5
199.992500	29.1	100.0	H	0.0	41.1	12.0	14.4	43.5
400.015000	33.2	125.0	V	240.0	51.1	17.9	12.8	46.0
800.018750	34.8	100.0	H	175.0	59.2	24.4	11.2	46.0

- Remark: 1. Quasi-Peak = Reading value + Correction factor
 2. Correction Factor = Antenna factor+ Insertion loss (cable loss+amplifier gain)
 3. Margin = Limit – Quasi-Peak

RE 1G-3GHz PK+AV

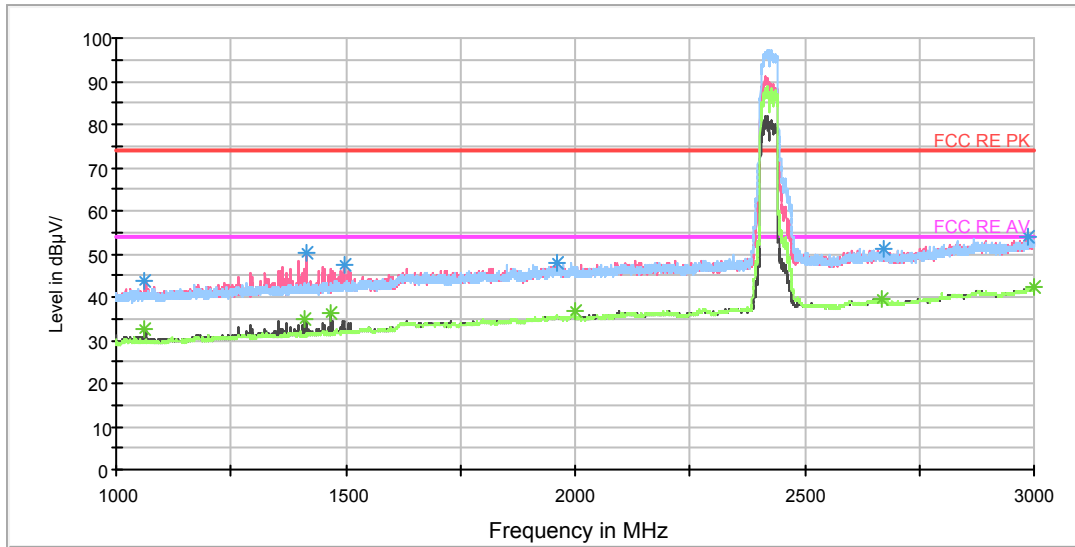

Note: The signal beyond the limit is carrier.

Radiates Emission from 1GHz to 3GHz

Frequency (MHz)	Peak (dBuV/m)	Height (cm)	Polarization	Azimuth (deg)	Reading value (dBuV/m)	Correct Factor (dB)	Margin (dB)	Limit (dBuV/m)
1062.000000	43.9	101.0	V	213.0	52.8	-8.9	30.1	74
1413.250000	50.4	101.0	V	259.0	57.5	-7.1	23.6	74
1495.750000	47.6	101.0	V	213.0	54.3	-6.7	26.4	74
1961.000000	48.0	101.0	V	334.0	51.2	-3.2	26.0	74
2673.250000	51.0	101.0	H	1.0	51.2	0.2	23.0	74
2986.250000	53.8	101.0	H	317.0	56.0	2.2	20.2	74

Remark: 1. Correction Factor = Antenna factor+ Insertion loss (cable loss + amplifier gain)

Frequency (MHz)	Average (dBuV/m)	Height (cm)	Polarization	Azimuth (deg)	Reading value (dBuV/m)	Correct Factor (dB)	Margin (dB)	Limit (dBuV/m)
1063.000000	32.4	101.0	V	213.0	41.3	-8.9	21.6	54
1409.500000	34.9	101.0	V	81.0	42.0	-7.1	19.1	54
1466.000000	36.2	101.0	V	241.0	43.0	-6.8	17.8	54
2000.250000	36.7	101.0	H	10.0	40.1	-3.4	17.3	54
2666.500000	39.3	101.0	H	0.0	39.6	0.3	14.7	54
2999.750000	42.3	101.0	V	0.0	44.6	2.3	11.7	54

Remark: 1. Correction Factor = Antenna factor+ Insertion loss (cable loss + amplifier gain)

RE 3-18GHz PK+AV

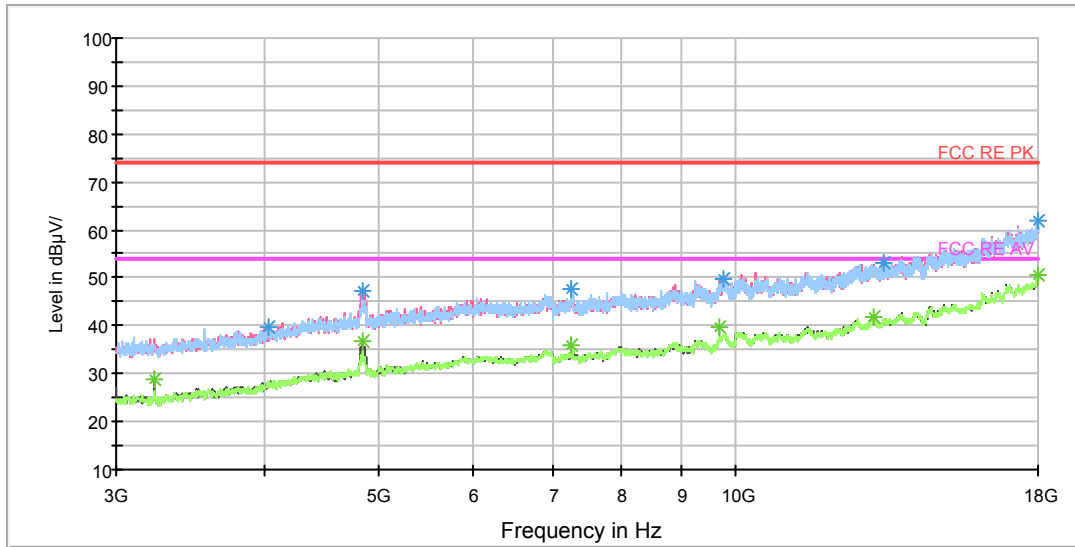

Radiates Emission from 3GHz to 18GHz

Frequency (MHz)	Peak (dBuV/m)	Height (cm)	Polarization	Azimuth (deg)	Reading value (dBuV/m)	Correct Factor (dB)	Margin (dB)	Limit (dBuV/m)
4038.750000	39.5	101.0	V	204.0	40.1	0.6	34.5	74
4841.250000	47.5	101.0	V	187.0	50.3	2.8	26.5	74
7267.500000	47.7	101.0	H	173.0	56.4	8.7	26.3	74
9778.125000	49.8	101.0	V	0.0	61.8	12.0	24.2	74
13351.875000	53.0	101.0	H	66.0	68.8	15.8	21.0	74
17985.000000	62.0	101.0	H	36.0	87.2	25.2	12.0	74

Remark: 1. Correction Factor = Antenna factor+ Insertion loss (cable loss + amplifier gain)

Frequency (MHz)	Average (dBuV/m)	Height (cm)	Polarization	Azimuth (deg)	Reading value (dBuV/m)	Correct Factor (dB)	Margin (dB)	Limit (dBuV/m)
3228.750000	28.6	101.0	V	0.0	30.2	-1.6	25.4	54
4839.375000	36.7	101.0	V	173.0	39.5	2.8	17.3	54
7275.000000	36.0	101.0	H	187.0	44.7	8.7	18.0	54
9688.125000	39.7	101.0	H	203.0	50.6	10.9	14.3	54
13063.125000	41.8	101.0	V	326.0	58.0	16.2	12.2	54
17996.250000	50.5	101.0	H	234.0	75.9	25.4	3.5	54

Remark: 1. Correction Factor = Antenna factor+ Insertion loss (cable loss + amplifier gain)

RE 18-26.5GHz PK+AV

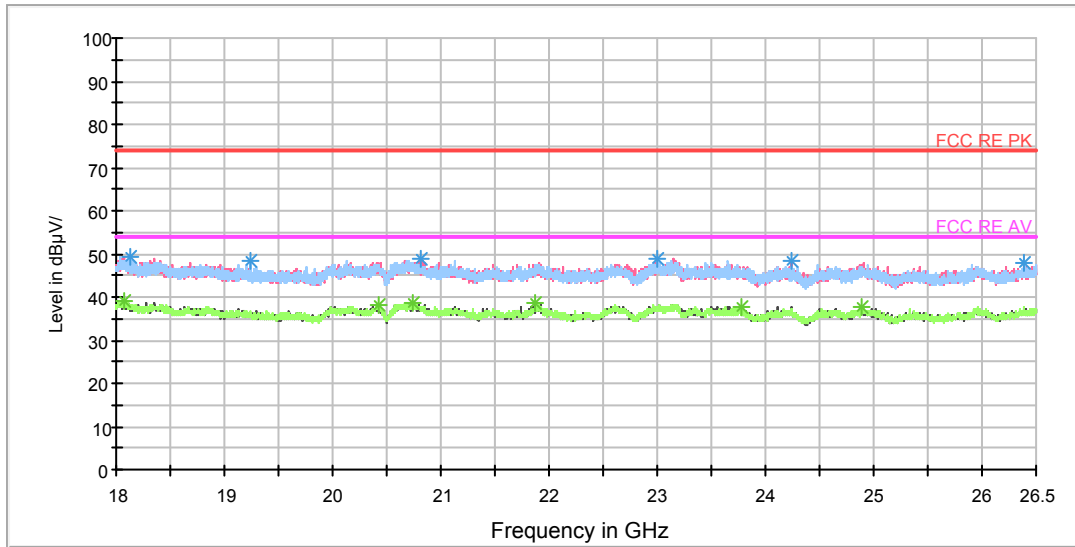

Radiates Emission from 18GHz to 26.5GHz

Frequency (MHz)	Peak (dBuV/m)	Height (cm)	Polarization	Azimuth (deg)	Reading value (dBuV/m)	Correct Factor (dB)	Margin (dB)	Limit (dBuV/m)
18121.125000	49.2	101.0	H	240.0	51.5	-2.3	24.8	74
19242.062500	48.5	101.0	H	188.0	54.1	-5.6	25.5	74
20812.437500	48.8	101.0	V	309.0	55.8	-7.0	25.2	74
22994.812500	49.1	101.0	H	38.0	55.3	-6.2	24.9	74
24248.562500	48.2	101.0	V	260.0	54.1	-5.9	25.8	74
26392.687500	47.8	101.0	H	14.0	53.2	-5.4	26.2	74

Remark: 1. Correction Factor = Antenna factor+ Insertion loss (cable loss + amplifier gain)

Frequency (MHz)	Average (dBuV/m)	Height (cm)	Polarization	Azimuth (deg)	Reading value (dBuV/m)	Correct Factor (dB)	Margin (dB)	Limit (dBuV/m)
18068.000000	39.1	101.0	V	137.0	41.2	-2.1	14.9	54
20431.000000	38.2	101.0	H	164.0	44.3	-6.1	15.8	54
20731.687500	38.6	101.0	H	14.0	45.4	-6.8	15.4	54
21870.687500	38.4	101.0	V	345.0	46.4	-8.0	15.6	54
23769.375000	37.9	101.0	V	0.0	43.8	-5.9	16.1	54
24888.187500	37.7	101.0	V	44.0	43.6	-5.9	16.3	54

Remark: 1. Correction Factor = Antenna factor+ Insertion loss (cable loss + amplifier gain)



802.11n (HT40) CH6

FCC RE 0.03-1GHz QP Class C

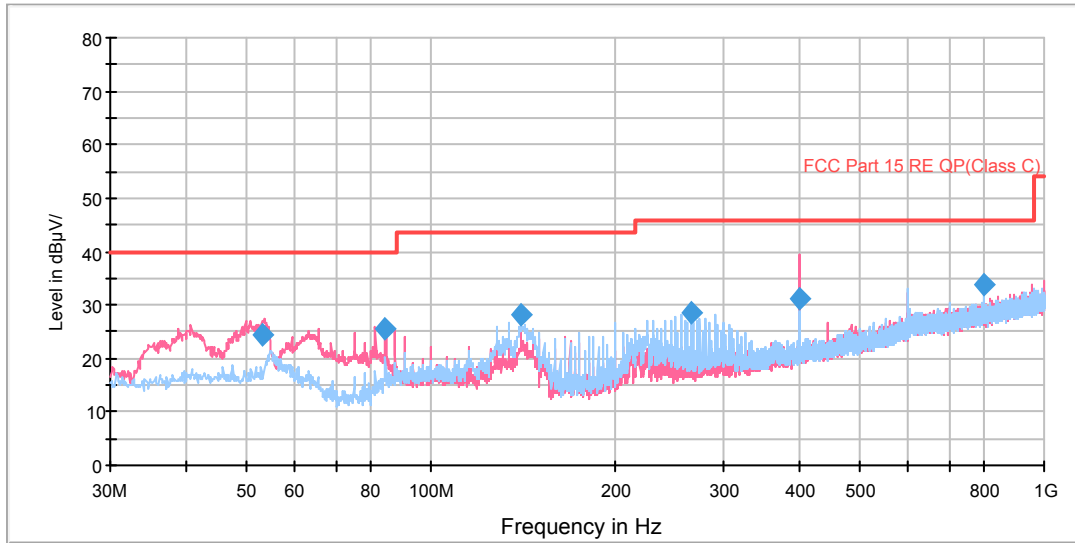

Radiates Emission from 30MHz to 1GHz

Frequency (MHz)	Quasi-Peak (dBuV/m)	Height (cm)	Polarization	Azimuth (deg)	Reading value (dBuV/m)	Correct Factor (dB)	Margin (dB)	Limit (dBuV/m)
53.122500	24.5	100.0	V	221.0	37.3	12.8	15.5	40.0
84.360000	25.4	125.0	V	309.0	35.4	10.0	14.6	40.0
140.620000	28.3	125.0	H	27.0	37.2	8.9	15.2	43.5
265.628750	28.4	100.0	H	19.0	42.9	14.5	17.6	46.0
400.015000	31.1	125.0	V	180.0	49.0	17.9	14.9	46.0
800.018750	33.8	100.0	H	190.0	58.2	24.4	12.2	46.0

- Remark:**
1. Quasi-Peak = Reading value + Correction factor
 2. Correction Factor = Antenna factor+ Insertion loss (cable loss+amplifier gain)
 3. Margin = Limit – Quasi-Peak

RE 1G-3GHz PK+AV

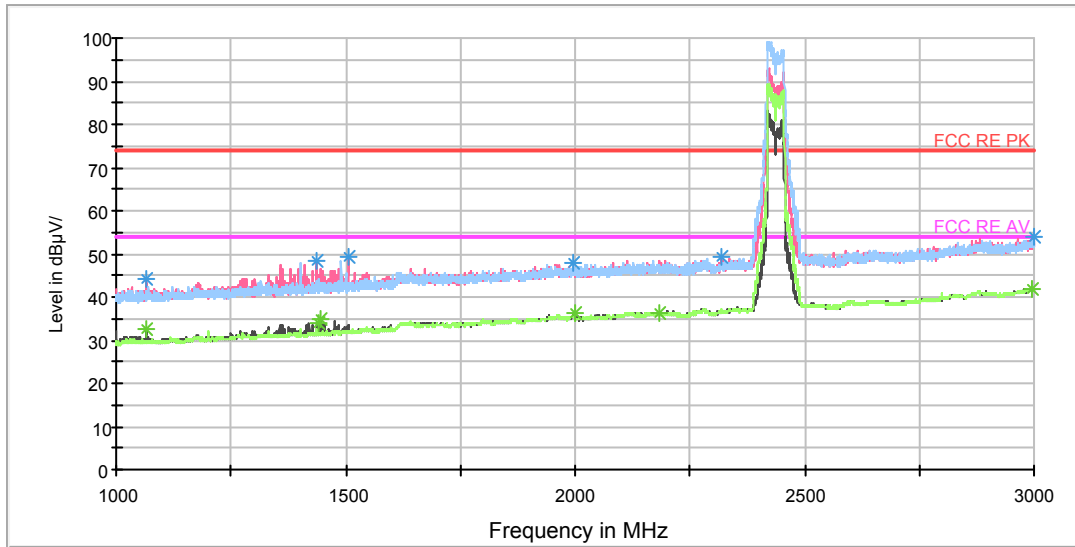

Note: The signal beyond the limit is carrier.

Radiates Emission from 1GHz to 3GHz

Frequency (MHz)	Peak (dBuV/m)	Height (cm)	Polarization	Azimuth (deg)	Reading value (dBuV/m)	Correct Factor (dB)	Margin (dB)	Limit (dBuV/m)
1065.500000	44.1	101.0	V	211.0	53.0	-8.9	29.9	74
1437.750000	48.4	101.0	V	146.0	55.3	-6.9	25.6	74
1505.000000	49.3	101.0	V	230.0	55.9	-6.6	24.7	74
1997.750000	48.1	101.0	H	109.0	51.4	-3.3	25.9	74
2317.250000	49.3	101.0	V	302.0	51.1	-1.8	24.7	74
2999.000000	53.9	101.0	H	119.0	56.2	2.3	20.1	74

Remark: 1. Correction Factor = Antenna factor+ Insertion loss (cable loss + amplifier gain)

Frequency (MHz)	Average (dBuV/m)	Height (cm)	Polarization	Azimuth (deg)	Reading value (dBuV/m)	Correct Factor (dB)	Margin (dB)	Limit (dBuV/m)
1065.750000	32.5	101.0	V	202.0	41.4	-8.9	21.5	54
1439.250000	34.1	101.0	V	257.0	41.0	-6.9	19.9	54
1445.750000	35.0	101.0	V	202.0	41.7	-6.7	19.0	54
2000.000000	36.3	101.0	H	36.0	39.7	-3.4	17.7	54
2185.500000	36.5	101.0	H	27.0	38.7	-2.2	17.5	54
2995.500000	42.1	101.0	V	275.0	44.4	2.3	11.9	54

Remark: 1. Correction Factor = Antenna factor+ Insertion loss (cable loss + amplifier gain)

RE 3-18GHz PK+AV

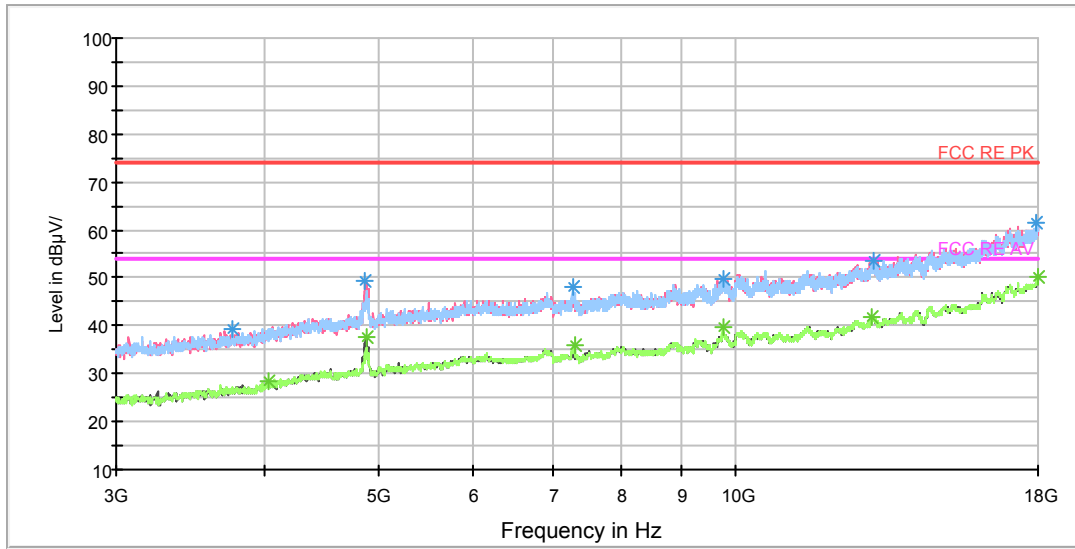

Radiates Emission from 3GHz to 18GHz

Frequency (MHz)	Peak (dBuV/m)	Height (cm)	Polarization	Azimuth (deg)	Reading value (dBuV/m)	Correct Factor (dB)	Margin (dB)	Limit (dBuV/m)
3757.500000	39.4	101.0	H	17.0	39.8	-0.4	34.6	74
4871.250000	49.2	101.0	V	191.0	52.2	3.0	24.8	74
7280.625000	48.1	101.0	H	158.0	56.8	8.7	25.9	74
9781.875000	49.9	101.0	H	33.0	62.0	12.1	24.1	74
13083.750000	53.5	101.0	H	313.0	69.7	16.2	20.5	74
17928.750000	61.5	101.0	V	297.0	86.1	24.6	12.5	74

Remark: 1. Correction Factor = Antenna factor+ Insertion loss (cable loss + amplifier gain)

Frequency (MHz)	Average (dBuV/m)	Height (cm)	Polarization	Azimuth (deg)	Reading value (dBuV/m)	Correct Factor (dB)	Margin (dB)	Limit (dBuV/m)
4036.875000	28.4	101.0	V	48.0	29.0	0.6	25.6	54
4882.500000	37.8	101.0	V	191.0	40.8	3.0	16.2	54
7306.875000	35.9	101.0	H	189.0	44.5	8.6	18.1	54
9748.125000	39.9	101.0	H	204.0	51.5	11.6	14.1	54
13042.500000	41.8	101.0	H	174.0	58.0	16.2	12.2	54
17998.125000	50.4	101.0	V	144.0	75.8	25.4	3.6	54

Remark: 1. Correction Factor = Antenna factor+ Insertion loss (cable loss + amplifier gain)



RE 18-26.5GHz PK+AV

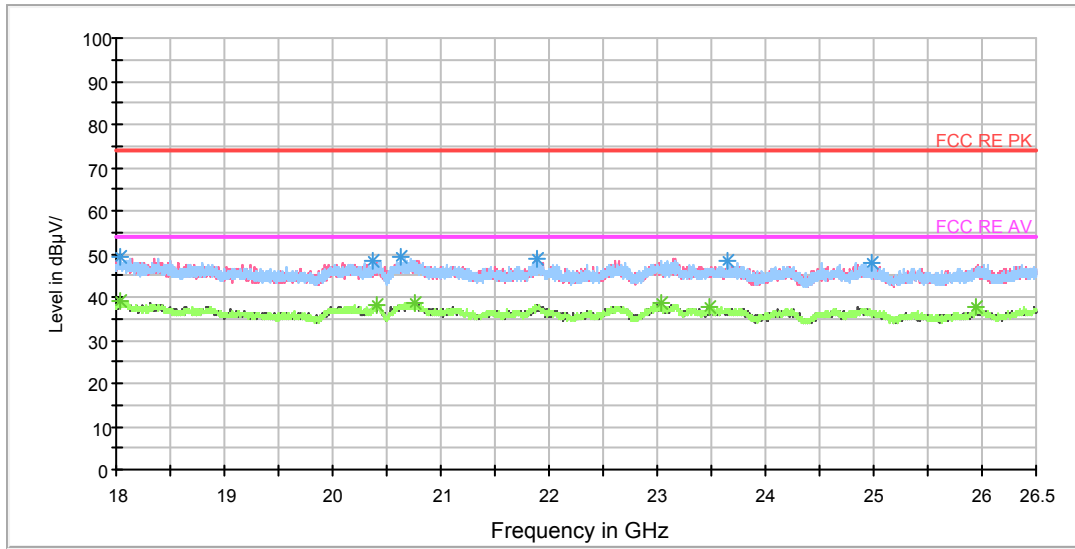

Radiates Emission from 18GHz to 26.5GHz

Frequency (MHz)	Peak (dBuV/m)	Height (cm)	Polarization	Azimuth (deg)	Reading value (dBuV/m)	Correct Factor (dB)	Margin (dB)	Limit (dBuV/m)
18042.500000	49.1	101.0	V	0.0	51.1	-2.0	24.9	74
20372.562500	48.5	101.0	H	228.0	54.6	-6.1	25.5	74
20633.937500	49.4	101.0	H	17.0	55.9	-6.5	24.6	74
21894.062500	49.0	101.0	H	66.0	57.0	-8.0	25.0	74
23640.812500	48.2	101.0	H	0.0	54.1	-5.9	25.8	74
24990.187500	47.9	101.0	H	349.0	53.8	-5.9	26.1	74

Remark: 1. Correction Factor = Antenna factor+ Insertion loss (cable loss + amplifier gain)

Frequency (MHz)	Average (dBuV/m)	Height (cm)	Polarization	Azimuth (deg)	Reading value (dBuV/m)	Correct Factor (dB)	Margin (dB)	Limit (dBuV/m)
18038.250000	39.0	101.0	V	323.0	41.0	-2.0	15.0	54
20407.625000	38.2	101.0	H	291.0	44.3	-6.1	15.8	54
20764.625000	38.6	101.0	H	202.0	45.4	-6.8	15.4	54
23030.937500	38.6	101.0	H	291.0	44.7	-6.1	15.4	54
23479.312500	37.7	101.0	V	71.0	43.6	-5.9	16.3	54
25939.000000	37.8	101.0	H	0.0	43.2	-5.4	16.2	54

Remark: 1. Correction Factor = Antenna factor+ Insertion loss (cable loss + amplifier gain)

802.11n (HT40) CH9

FCC RE 0.03-1GHz QP Class C

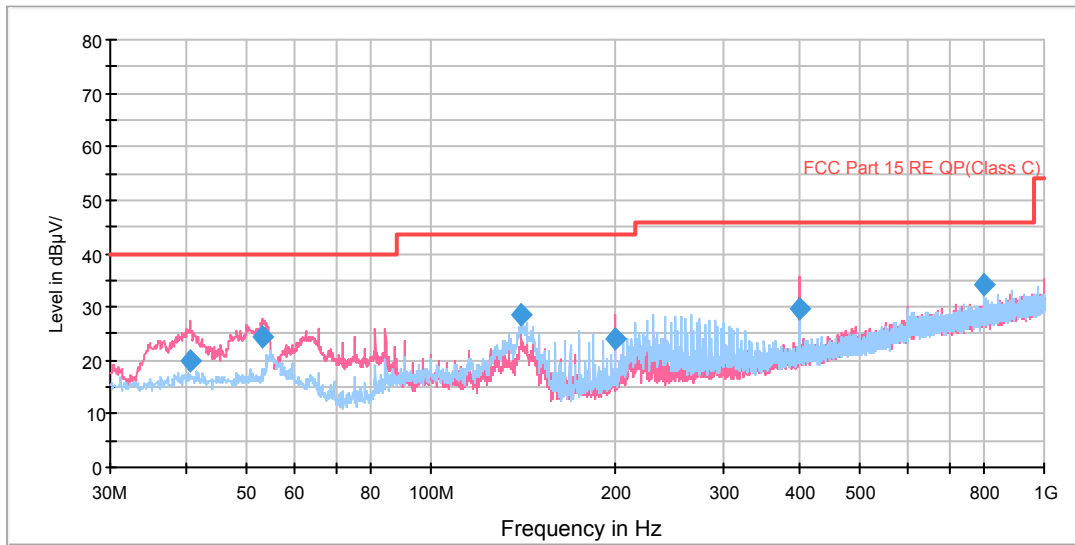

Radiates Emission from 30MHz to 1GHz

Frequency (MHz)	Quasi-Peak (dBuV/m)	Height (cm)	Polarization	Azimuth (deg)	Reading value (dBuV/m)	Correct Factor (dB)	Margin (dB)	Limit (dBuV/m)
40.388750	20.0	100.0	V	266.0	33.2	13.2	20.0	40.0
53.118750	24.4	100.0	V	245.0	37.2	12.8	15.6	40.0
140.620000	28.4	125.0	H	34.0	37.3	8.9	15.1	43.5
199.991250	24.1	125.0	V	209.0	36.1	12.0	19.4	43.5
399.975000	29.7	100.0	V	0.0	47.6	17.9	16.3	46.0
800.018750	34.0	100.0	H	184.0	58.4	24.4	12.0	46.0

- Remark:**
1. Quasi-Peak = Reading value + Correction factor
 2. Correction Factor = Antenna factor+ Insertion loss (cable loss+amplifier gain)
 3. Margin = Limit – Quasi-Peak

RE 1G-3GHz PK+AV

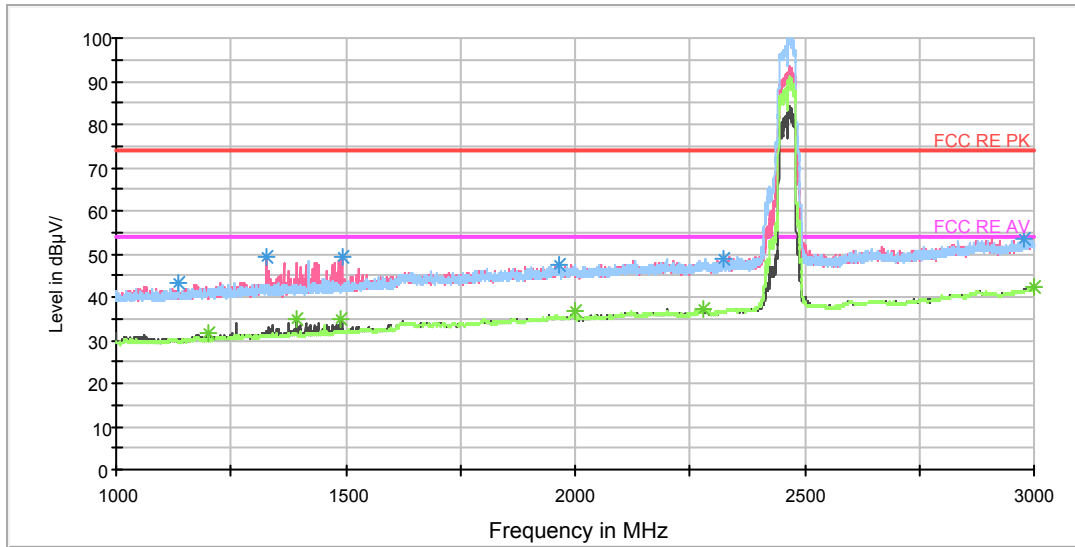

Note: The signal beyond the limit is carrier.
Radiates Emission from 1GHz to 3GHz

Frequency (MHz)	Peak (dBuV/m)	Height (cm)	Polarization	Azimuth (deg)	Reading value (dBuV/m)	Correct Factor (dB)	Margin (dB)	Limit (dBuV/m)
1133.500000	43.2	101.0	H	241.0	51.6	-8.4	30.8	74
1328.500000	49.4	101.0	V	215.0	56.8	-7.4	24.6	74
1491.500000	49.5	101.0	V	122.0	56.2	-6.7	24.5	74
1964.000000	47.6	101.0	V	34.0	50.9	-3.3	26.4	74
2325.000000	48.9	101.0	H	17.0	50.5	-1.6	25.1	74
2979.750000	53.6	101.0	V	243.0	55.8	2.2	20.4	74

Remark: 1. Correction Factor = Antenna factor+ Insertion loss (cable loss + amplifier gain)

Frequency (MHz)	Average (dBuV/m)	Height (cm)	Polarization	Azimuth (deg)	Reading value (dBuV/m)	Correct Factor (dB)	Margin (dB)	Limit (dBuV/m)
1200.000000	31.8	101.0	V	168.0	40.0	-8.2	22.2	54
1392.000000	34.7	101.0	V	243.0	41.7	-7.0	19.3	54
1487.750000	34.9	101.0	V	205.0	41.6	-6.7	19.1	54
2000.000000	36.7	101.0	H	8.0	40.1	-3.4	17.3	54
2280.250000	37.1	101.0	V	279.0	38.4	-1.3	16.9	54
3000.000000	42.2	101.0	V	215.0	44.5	2.3	11.8	54

Remark: 1. Correction Factor = Antenna factor+ Insertion loss (cable loss + amplifier gain)

RE 3-18GHz PK+AV

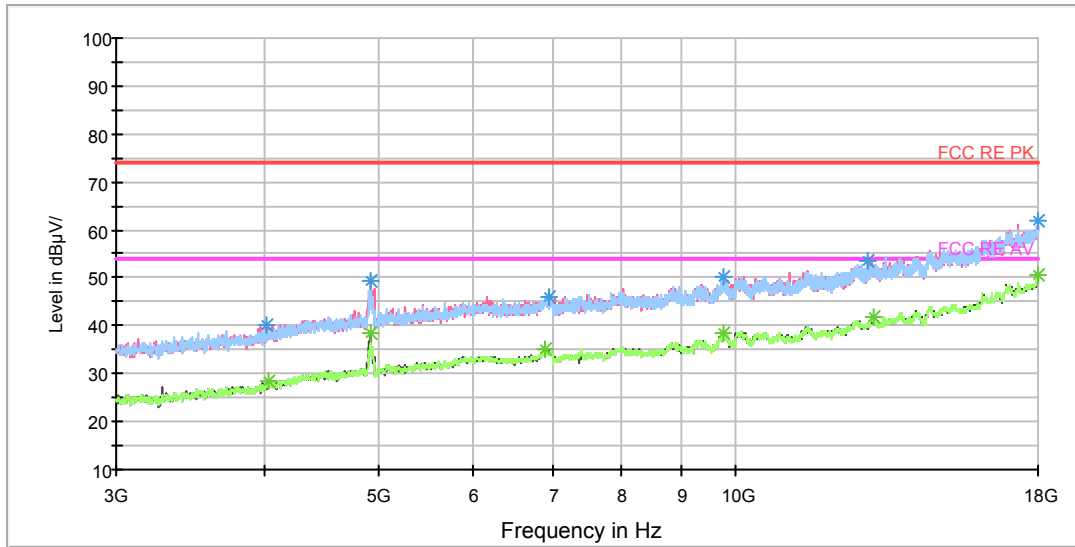

Radiates Emission from 3GHz to 18GHz

Frequency (MHz)	Peak (dBuV/m)	Height (cm)	Polarization	Azimuth (deg)	Reading value (dBuV/m)	Correct Factor (dB)	Margin (dB)	Limit (dBuV/m)
4023.750000	40.2	101.0	V	190.0	40.8	0.6	33.8	74
4927.500000	49.2	101.0	V	174.0	52.3	3.1	24.8	74
6950.625000	46.2	101.0	H	18.0	52.9	6.7	27.8	74
9748.125000	50.4	101.0	V	235.0	62.0	11.6	23.6	74
12943.125000	53.5	101.0	H	156.0	69.8	16.3	20.5	74
17996.250000	61.8	101.0	H	232.0	87.2	25.4	12.2	74

Remark: 1. Correction Factor = Antenna factor+ Insertion loss (cable loss + amplifier gain)

Frequency (MHz)	Average (dBuV/m)	Height (cm)	Polarization	Azimuth (deg)	Reading value (dBuV/m)	Correct Factor (dB)	Margin (dB)	Limit (dBuV/m)
4036.875000	28.6	101.0	H	64.0	29.2	0.6	25.4	54
4923.750000	38.4	101.0	V	174.0	41.5	3.1	15.6	54
6913.125000	35.0	101.0	H	94.0	41.9	6.9	19.0	54
9780.000000	38.3	101.0	V	311.0	50.3	12.0	15.7	54
13061.250000	41.7	101.0	H	3.0	57.9	16.2	12.3	54
17998.125000	50.6	101.0	V	0.0	76.0	25.4	3.4	54

Remark: 1. Correction Factor = Antenna factor+ Insertion loss (cable loss + amplifier gain)



RE 18-26.5GHz PK+AV

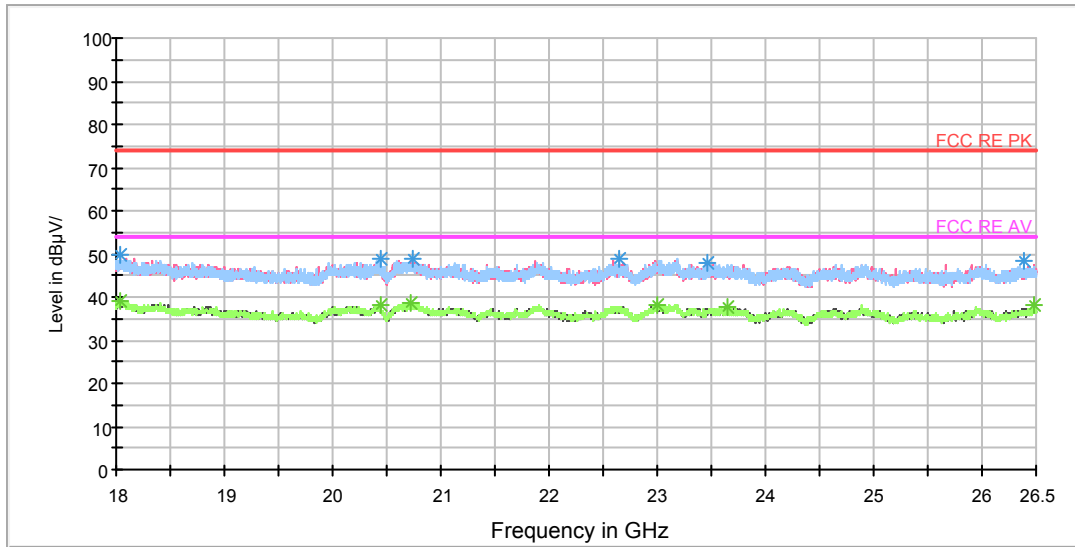

Radiates Emission from 18GHz to 26.5GHz

Frequency (MHz)	Peak (dBuV/m)	Height (cm)	Polarization	Azimuth (deg)	Reading value (dBuV/m)	Correct Factor (dB)	Margin (dB)	Limit (dBuV/m)
18037.187500	49.7	101.0	H	110.0	51.7	-2.0	24.3	74
20441.625000	48.7	101.0	H	60.0	54.8	-6.1	25.3	74
20740.187500	48.8	101.0	V	278.0	55.6	-6.8	25.2	74
22653.750000	49.1	101.0	H	227.0	55.7	-6.6	24.9	74
23469.750000	47.8	101.0	V	0.0	53.7	-5.9	26.2	74
26385.250000	48.3	101.0	H	0.0	53.7	-5.4	25.7	74

Remark: 1. Correction Factor = Antenna factor+ Insertion loss (cable loss + amplifier gain)

Frequency (MHz)	Average (dBuV/m)	Height (cm)	Polarization	Azimuth (deg)	Reading value (dBuV/m)	Correct Factor (dB)	Margin (dB)	Limit (dBuV/m)
18042.500000	38.9	101.0	V	178.0	40.9	-2.0	15.1	54
20444.812500	38.2	101.0	V	327.0	44.3	-6.1	15.8	54
20726.375000	38.7	101.0	H	47.0	45.5	-6.8	15.3	54
22995.875000	38.3	101.0	H	121.0	44.5	-6.2	15.7	54
23649.312500	37.6	101.0	H	160.0	43.5	-5.9	16.4	54
26476.625000	38.3	101.0	V	240.0	43.7	-5.4	15.7	54

Remark: 1. Correction Factor = Antenna factor+ Insertion loss (cable loss + amplifier gain)

5.8. Conducted Emission

Ambient condition

Temperature	Relative humidity	Pressure
23°C ~25°C	45%~50%	101.5kPa

Methods of Measurement

The EUT is placed on a non-metallic table of 80cm height above the horizontal metal reference ground plane. During the test, the EUT was operating in its typical mode. The test method is according to ANSI C63.10-2013. Connect the AC power line of the EUT to the L.I.S.N. Use EMI receiver to detect the average and Quasi-peak value. RBW is set to 9 kHz, VBW is set to 30kHz. The measurement result should include both L line and N line.

The test is in transmitting mode.

Test Setup

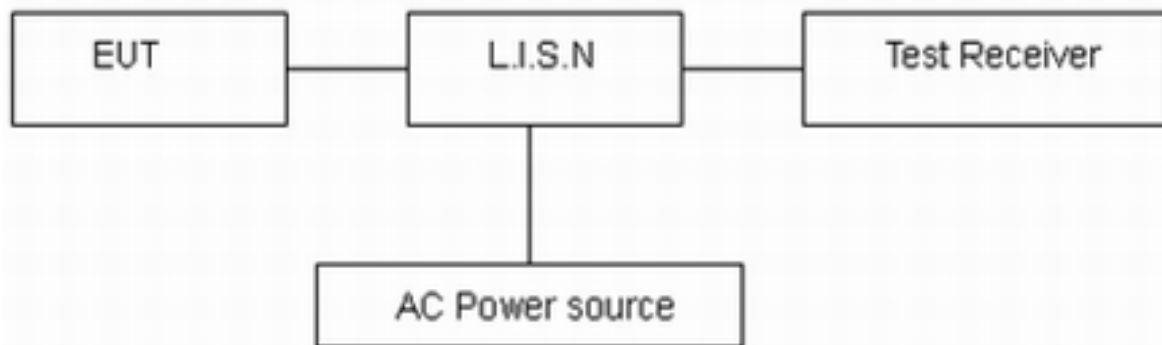

Note: AC Power source is used to change the voltage 110V/60Hz.

Limits

Frequency (MHz)	Conducted Limits(dBμV)	
	Quasi-peak	Average
0.15 - 0.5	66 to 56 *	56 to 46*
0.5 - 5	56	46
5 - 30	60	50

*: Decreases with the logarithm of the frequency.

Measurement Uncertainty

The assessed measurement uncertainty to ensure 95% confidence level for the normal distribution is with the coverage factor $k = 1.96$, $U = 2.69$ dB.



Test Results:

Following plots, Blue trace uses the peak detection and Green trace uses the average detection.

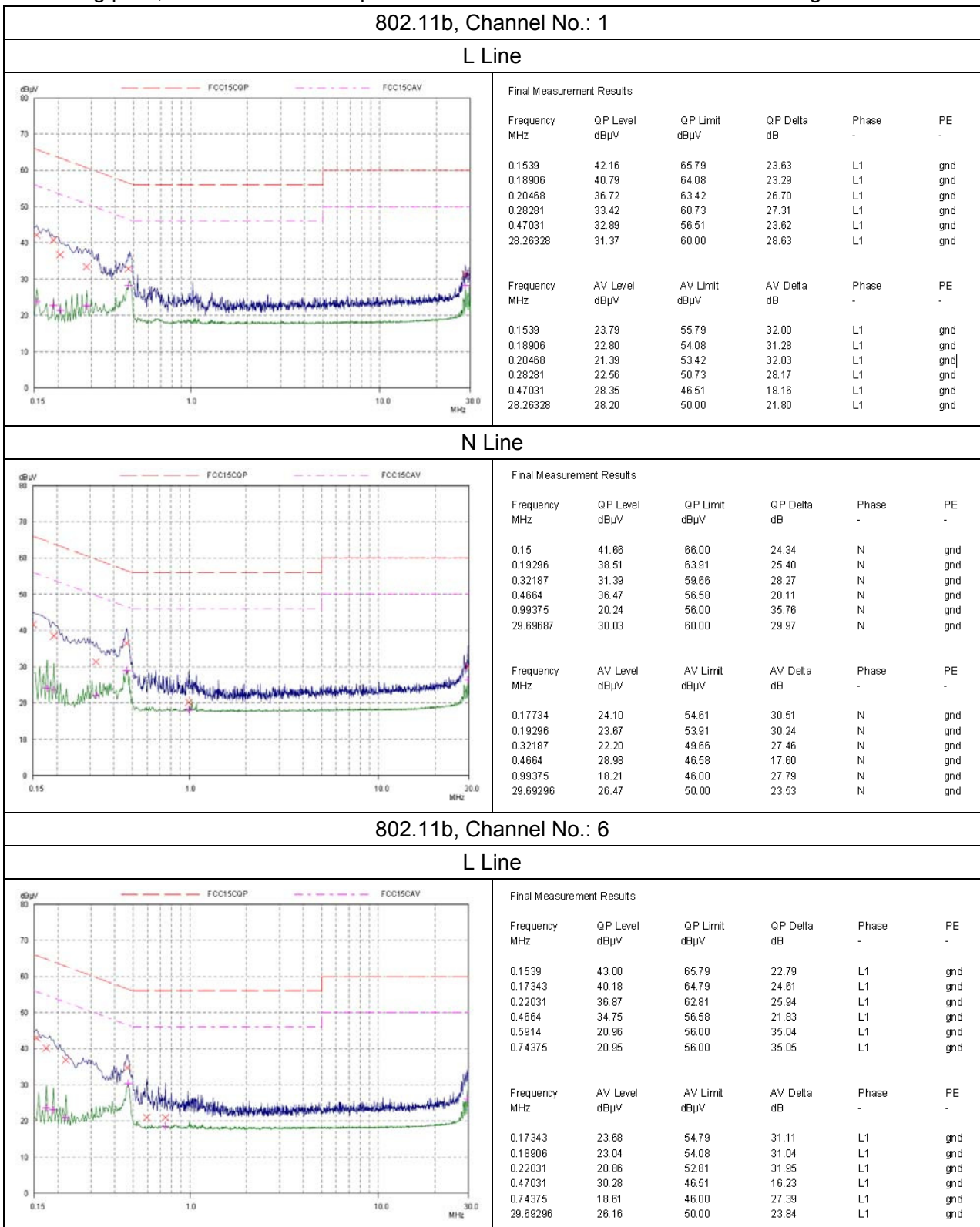

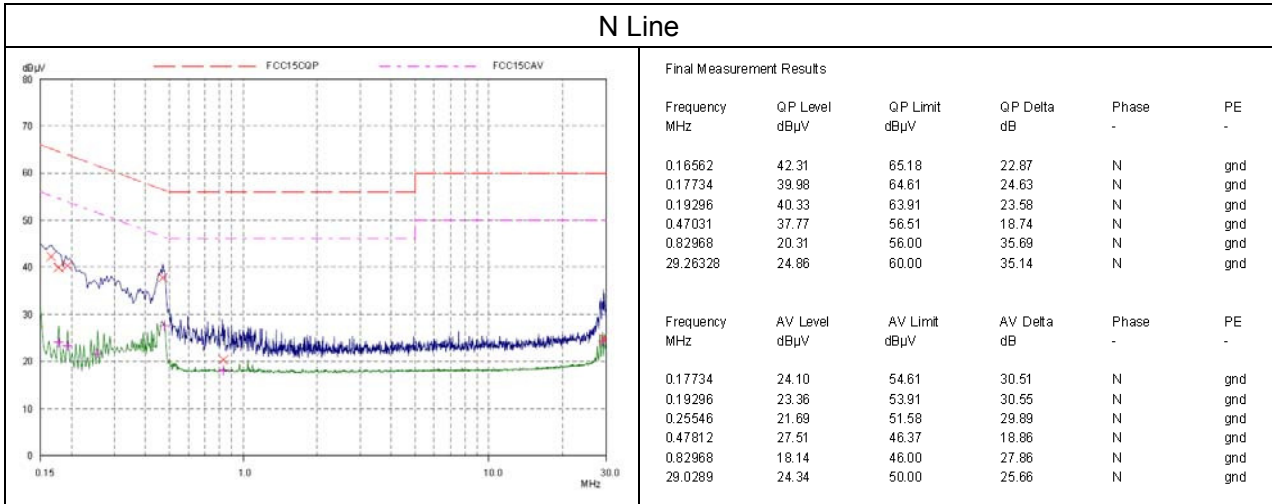

802.11b, Channel No.: 11

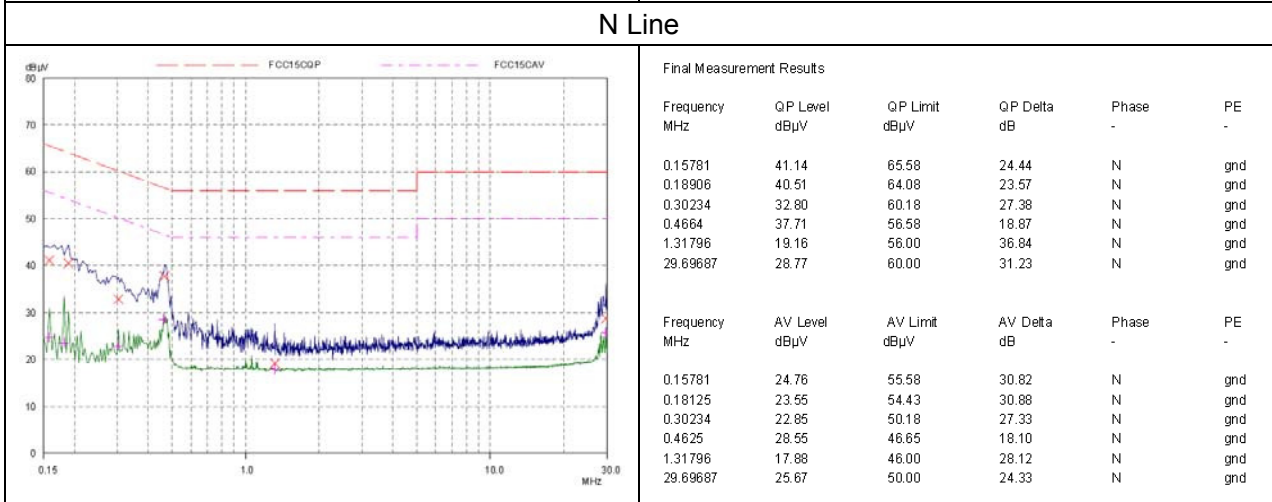
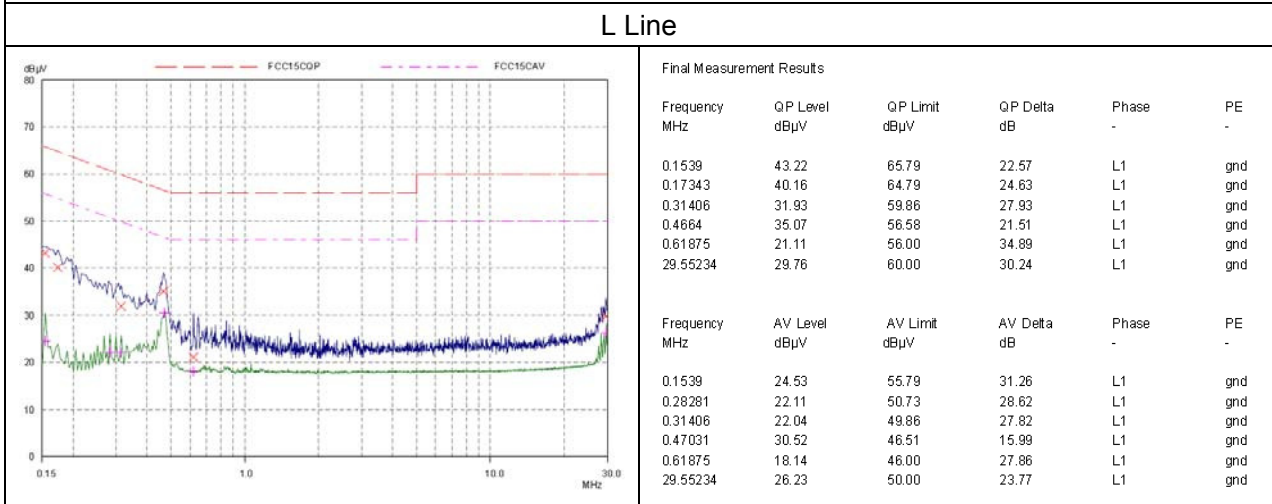



802.11g, Channel No.: 1

L Line

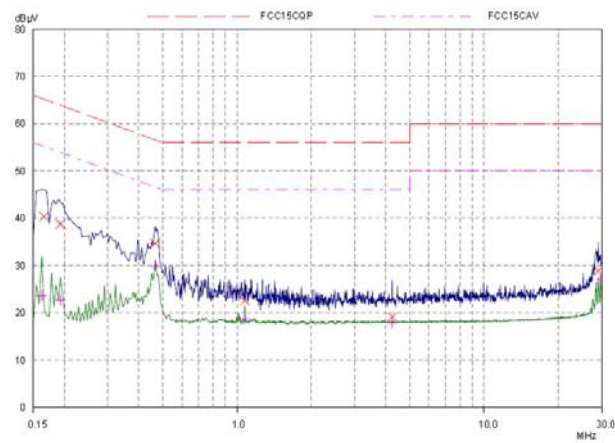

Final Measurement Results

Frequency MHz	QP Level dBµV	QP Limit dBµV	QP Delta dB	Phase	PE
0.16562	40.41	65.18	24.77	L1	gnd
0.19296	38.79	63.91	25.12	L1	gnd
0.4664	34.69	56.58	21.89	L1	gnd
1.07578	22.52	56.00	33.48	L1	gnd
4.24765	19.15	56.00	36.85	L1	gnd
29.0289	28.91	60.00	31.09	L1	gnd

Frequency MHz	AV Level dBµV	AV Limit dBµV	AV Delta dB	Phase	PE
0.16171	23.69	55.38	31.69	L1	gnd
0.19296	22.66	53.91	31.25	L1	gnd
0.4664	29.87	46.58	16.71	L1	gnd
1.07578	18.68	46.00	27.32	L1	gnd
4.24765	17.87	46.00	28.13	L1	gnd
29.69296	26.99	50.00	23.01	L1	gnd

N Line

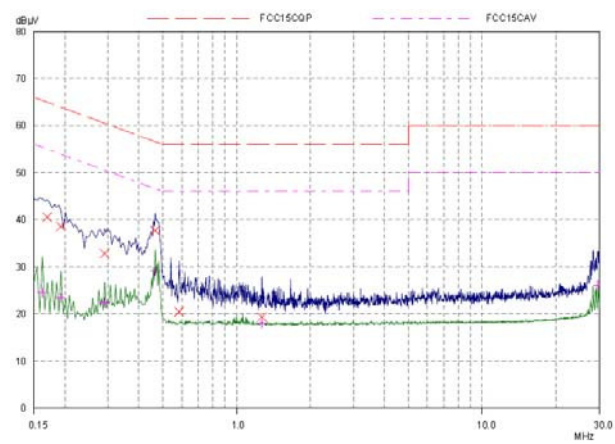

Final Measurement Results

Frequency MHz	QP Level dBµV	QP Limit dBµV	QP Delta dB	Phase	PE
0.16953	40.54	64.98	24.44	N	gnd
0.19296	38.57	63.91	25.34	N	gnd
0.29062	32.80	60.51	27.71	N	gnd
0.4664	37.73	56.58	18.85	N	gnd
0.58359	20.46	56.00	35.54	N	gnd
1.26718	19.34	56.00	36.66	N	gnd

Frequency MHz	AV Level dBµV	AV Limit dBµV	AV Delta dB	Phase	PE
0.16171	24.52	55.38	30.86	N	gnd
0.19296	23.41	53.91	30.50	N	gnd
0.29062	22.46	50.51	28.05	N	gnd
0.4664	29.07	46.58	17.51	N	gnd
1.26718	17.96	46.00	28.04	N	gnd
29.64609	26.08	50.00	23.92	N	gnd

802.11g, Channel No.: 6

L Line

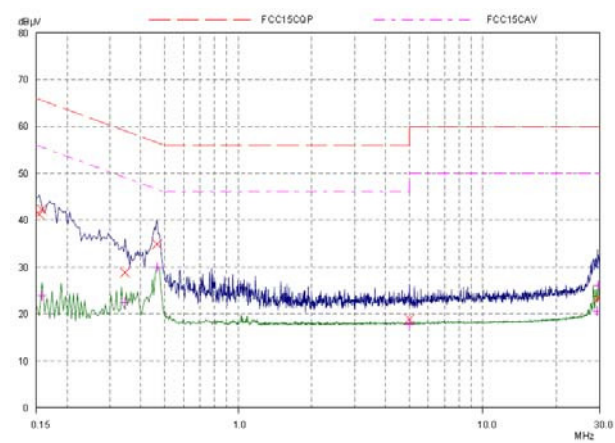

Final Measurement Results

Frequency MHz	QP Level dBµV	QP Limit dBµV	QP Delta dB	Phase	PE
0.1539	41.26	65.79	24.53	L1	gnd
0.15781	42.30	65.58	23.28	L1	gnd
0.34531	28.85	59.07	30.22	L1	gnd
0.4664	34.87	56.58	21.71	L1	gnd
5.01718	18.96	60.00	41.04	L1	gnd
29.49765	23.21	60.00	36.79	L1	gnd

Frequency MHz	AV Level dBµV	AV Limit dBµV	AV Delta dB	Phase	PE
0.15781	23.96	55.58	31.62	L1	gnd
0.34531	22.45	49.07	26.62	L1	gnd
0.4664	30.03	46.58	16.55	L1	gnd
5.01718	17.88	50.00	32.12	L1	gnd
29.49765	20.58	50.00	29.42	L1	gnd
29.69296	26.16	50.00	23.84	L1	gnd

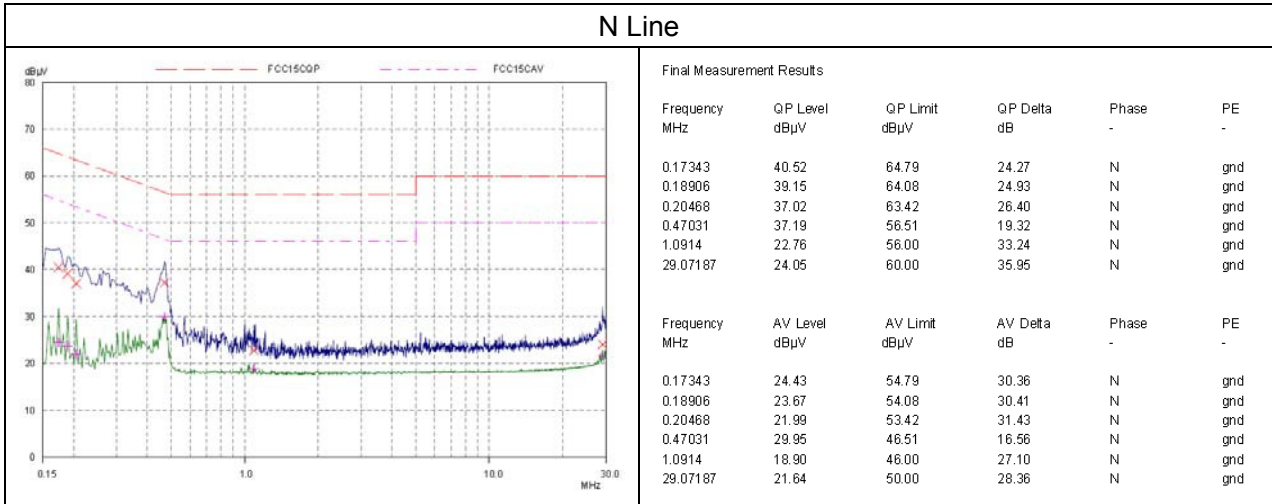

802.11g, Channel No.: 11

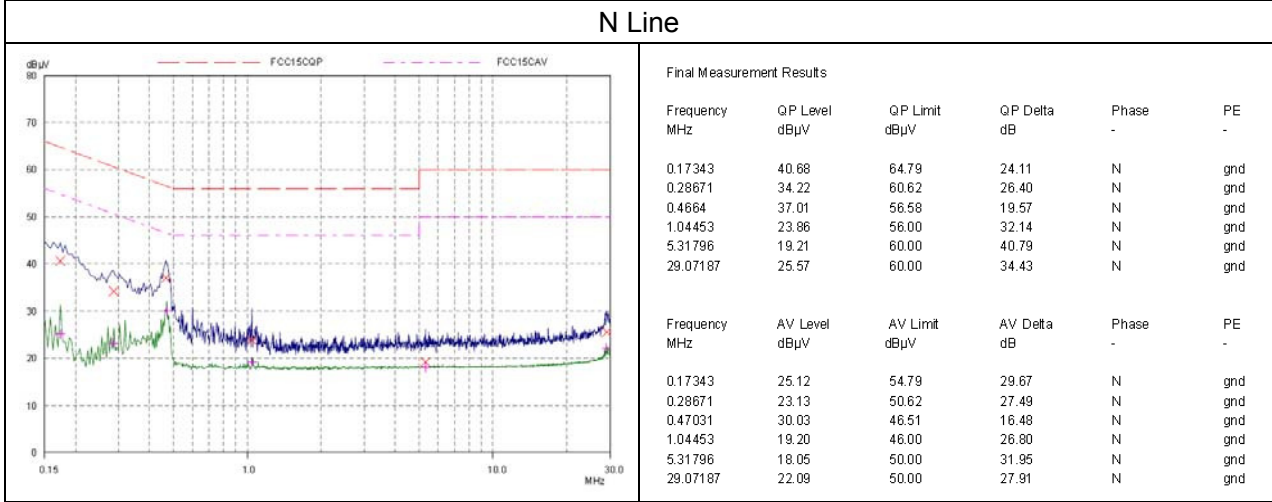
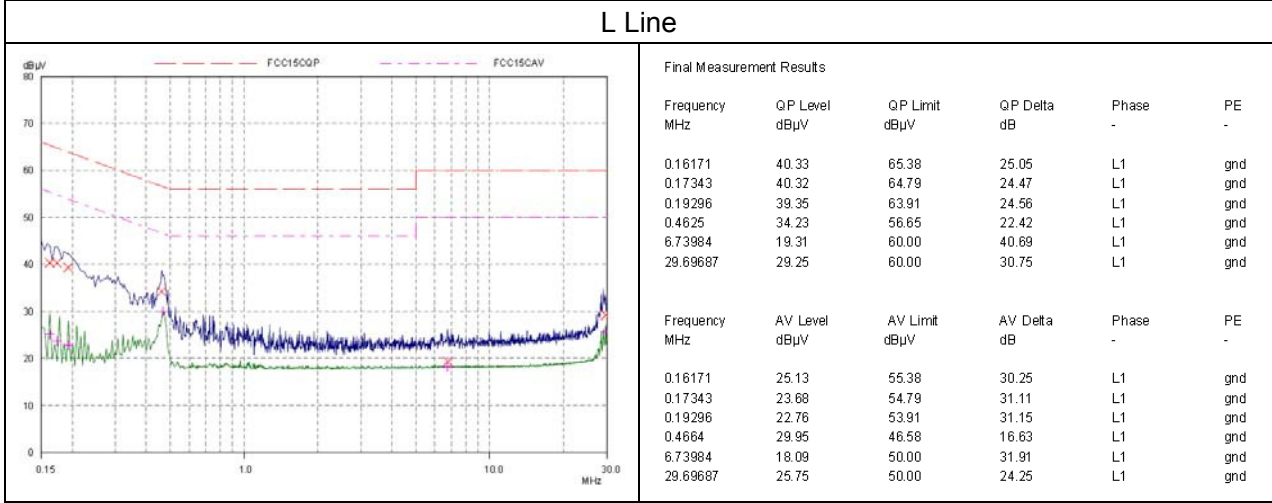



802.11n(HT20), Channel No.: 1

L Line

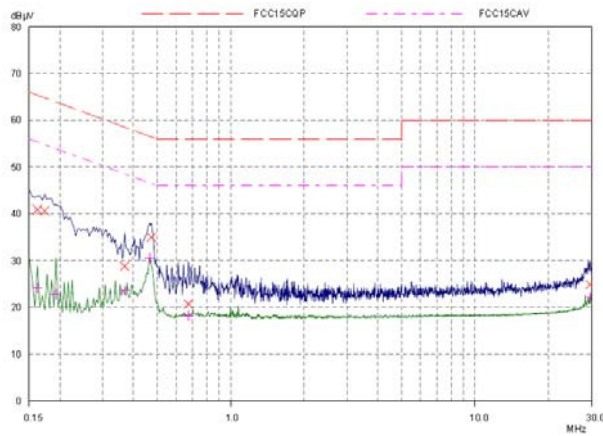

Final Measurement Results

Frequency MHz	QP Level dBµV	QP Limit dBµV	QP Delta dB	Phase	PE
0.16171	40.87	65.38	24.51	L1	gnd
0.17343	40.66	64.79	24.13	L1	gnd
0.36875	28.78	58.53	29.75	L1	gnd
0.47421	34.93	56.44	21.51	L1	gnd
0.67343	20.71	56.00	35.29	L1	gnd
29.55234	24.84	60.00	35.16	L1	gnd

Frequency MHz	AV Level dBµV	AV Limit dBµV	AV Delta dB	Phase	PE
0.16171	24.11	55.38	31.27	L1	gnd
0.19296	22.76	53.91	31.15	L1	gnd
0.36875	23.60	48.53	24.93	L1	gnd
0.4664	30.52	46.58	16.06	L1	gnd
0.67343	18.22	46.00	27.78	L1	gnd
29.55234	22.10	50.00	27.90	L1	gnd

N Line

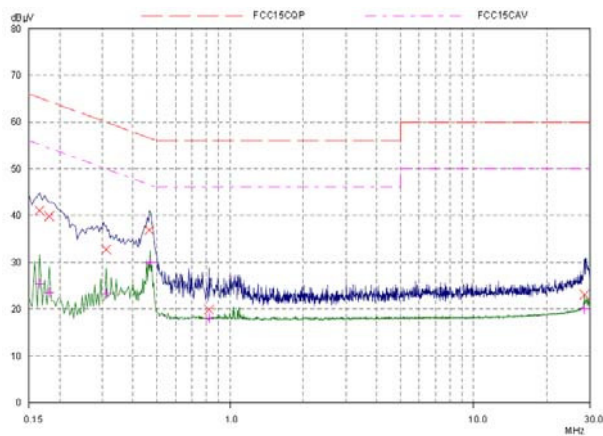

Final Measurement Results

Frequency MHz	QP Level dBµV	QP Limit dBµV	QP Delta dB	Phase	PE
0.16562	41.05	65.18	24.13	N	gnd
0.18125	39.86	64.43	24.57	N	gnd
0.31015	32.72	59.97	27.25	N	gnd
0.4664	36.91	56.58	19.67	N	gnd
0.82187	19.85	56.00	36.15	N	gnd
28.51718	23.06	60.00	36.94	N	gnd

Frequency MHz	AV Level dBµV	AV Limit dBµV	AV Delta dB	Phase	PE
0.16562	25.35	55.18	29.83	N	gnd
0.18125	23.55	54.43	30.88	N	gnd
0.31015	23.27	49.97	26.70	N	gnd
0.47031	29.95	46.51	16.56	N	gnd
0.82187	18.06	46.00	27.94	N	gnd
28.51718	20.07	50.00	29.93	N	gnd

802.11n(HT20), Channel No.: 6

L Line

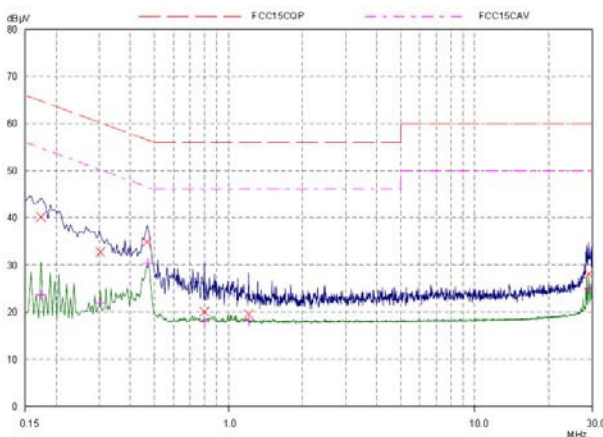

Final Measurement Results

Frequency MHz	QP Level dBµV	QP Limit dBµV	QP Delta dB	Phase	PE
0.17343	40.18	64.79	24.61	L1	gnd
0.30234	32.72	60.18	27.46	L1	gnd
0.4664	34.89	56.58	21.69	L1	gnd
0.79843	20.09	56.00	35.91	L1	gnd
1.20859	19.54	56.00	36.46	L1	gnd
29.0289	28.05	60.00	31.95	L1	gnd

Frequency MHz	AV Level dBµV	AV Limit dBµV	AV Delta dB	Phase	PE
0.17343	23.59	54.79	31.20	L1	gnd
0.30234	21.84	50.18	28.34	L1	gnd
0.47031	30.36	46.51	16.15	L1	gnd
0.79843	18.06	46.00	27.94	L1	gnd
1.20859	18.13	46.00	27.87	L1	gnd
29.0289	24.99	50.00	25.01	L1	gnd

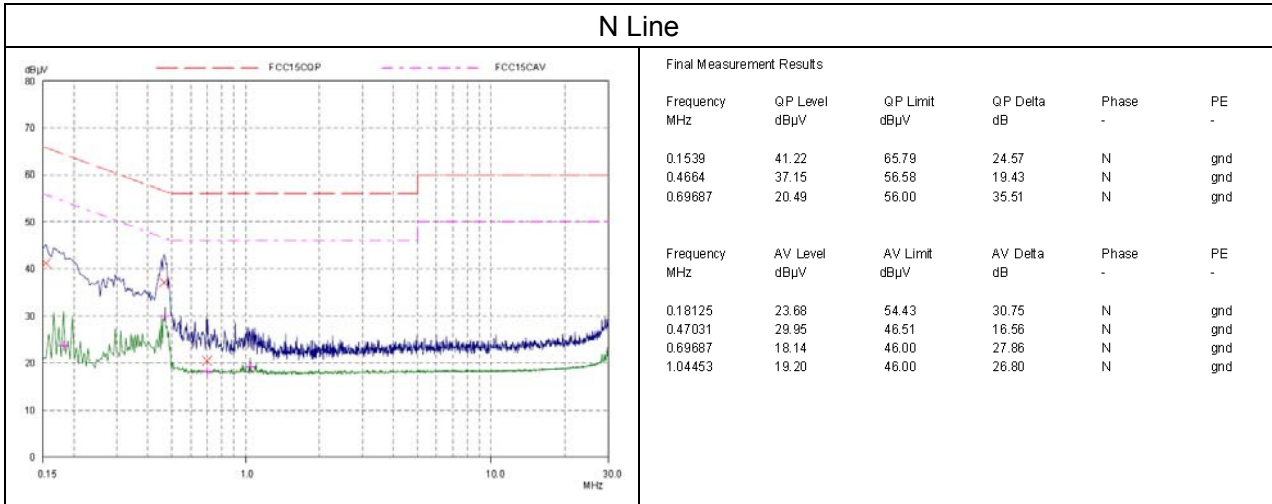

802.11n(HT20), Channel No.: 11

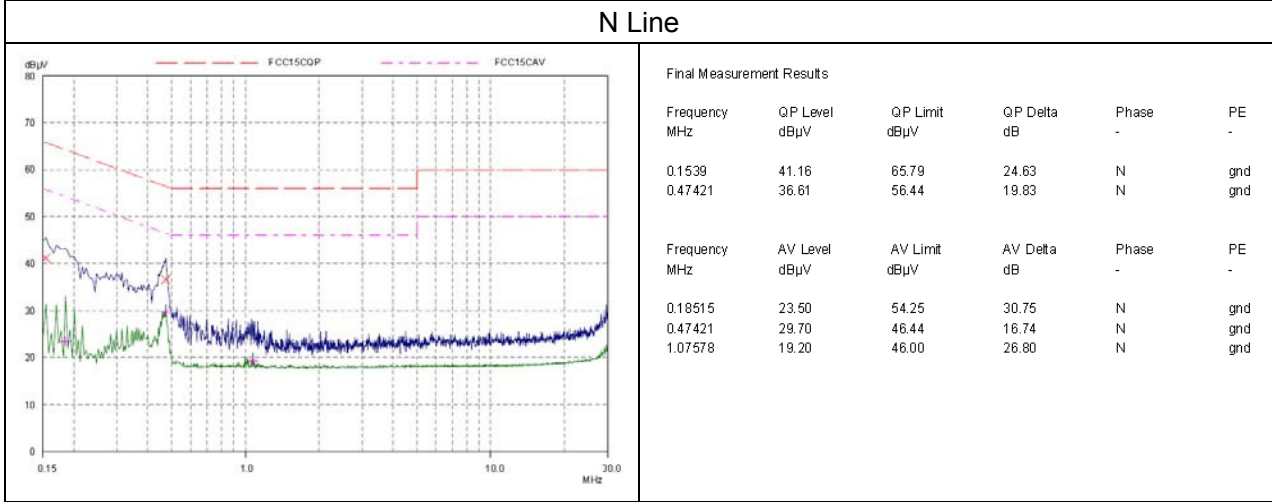
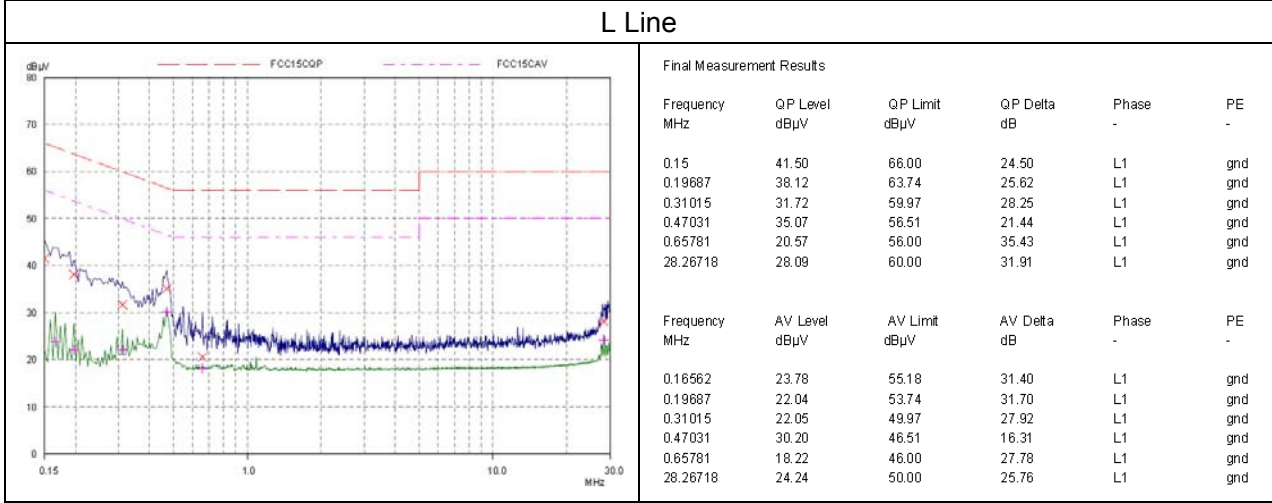



802.11n(HT40), Channel No.: 3

L Line

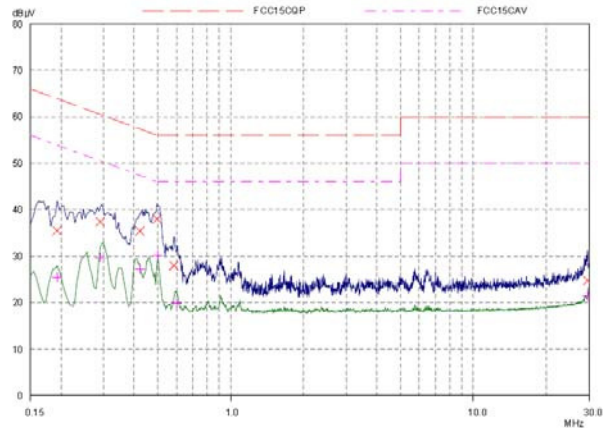

Final Measurement Results

Frequency MHz	QP Level dBµV	QP Limit dBµV	QP Delta dB	Phase	PE
0.19296	35.53	63.91	28.38	L1	gnd
0.29062	37.40	60.51	23.11	L1	gnd
0.42343	35.43	57.38	21.95	L1	gnd
0.49765	37.98	56.04	18.06	L1	gnd
0.58359	27.98	56.00	28.02	L1	gnd
29.50546	24.73	60.00	35.27	L1	gnd

Frequency MHz	AV Level dBµV	AV Limit dBµV	AV Delta dB	Phase	PE
0.19296	25.47	53.91	28.44	L1	gnd
0.29062	29.73	50.51	20.78	L1	gnd
0.42343	27.34	47.38	20.04	L1	gnd
0.50156	30.19	46.00	15.81	L1	gnd
0.59921	19.84	46.00	26.16	L1	gnd
29.50546	21.43	50.00	28.57	L1	gnd

N Line

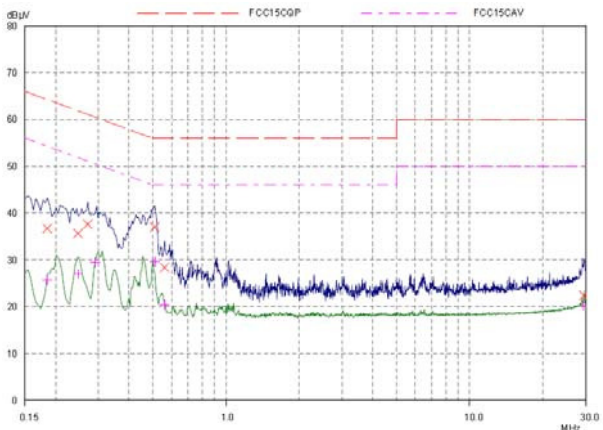

Final Measurement Results

Frequency MHz	QP Level dBµV	QP Limit dBµV	QP Delta dB	Phase	PE
0.18515	36.71	64.25	27.54	N	gnd
0.24765	35.66	61.84	26.18	N	gnd
0.27109	37.59	61.08	23.49	N	gnd
0.50937	37.00	56.00	19.00	N	gnd
0.56015	28.34	56.00	27.66	N	gnd
29.44687	22.36	60.00	37.64	N	gnd

Frequency MHz	AV Level dBµV	AV Limit dBµV	AV Delta dB	Phase	PE
0.18515	25.75	54.25	28.50	N	gnd
0.24765	26.99	51.84	24.85	N	gnd
0.29062	29.47	50.51	21.04	N	gnd
0.50937	29.60	46.00	16.40	N	gnd
0.56015	20.42	46.00	25.58	N	gnd
29.44687	20.19	50.00	29.81	N	gnd

802.11n(HT40), Channel No.: 6

L Line

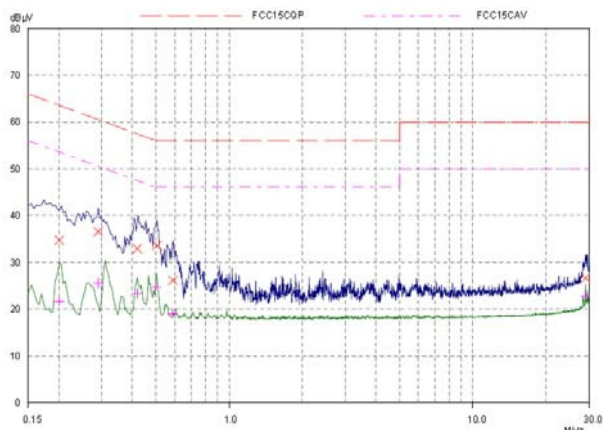

Final Measurement Results

Frequency MHz	QP Level dBµV	QP Limit dBµV	QP Delta dB	Phase	PE
0.20078	34.72	63.58	28.86	L1	gnd
0.29062	36.52	60.51	23.99	L1	gnd
0.41953	32.91	57.46	24.55	L1	gnd
0.50546	33.56	56.00	22.44	L1	gnd
0.5875	26.10	56.00	29.90	L1	gnd
29.07578	26.63	60.00	33.37	L1	gnd

Frequency MHz	AV Level dBµV	AV Limit dBµV	AV Delta dB	Phase	PE
0.20078	21.67	53.58	31.91	L1	gnd
0.29062	25.56	50.51	24.95	L1	gnd
0.41953	23.37	47.46	24.09	L1	gnd
0.50156	24.79	46.00	21.21	L1	gnd
0.5875	19.14	46.00	26.86	L1	gnd
29.07578	22.81	50.00	27.19	L1	gnd

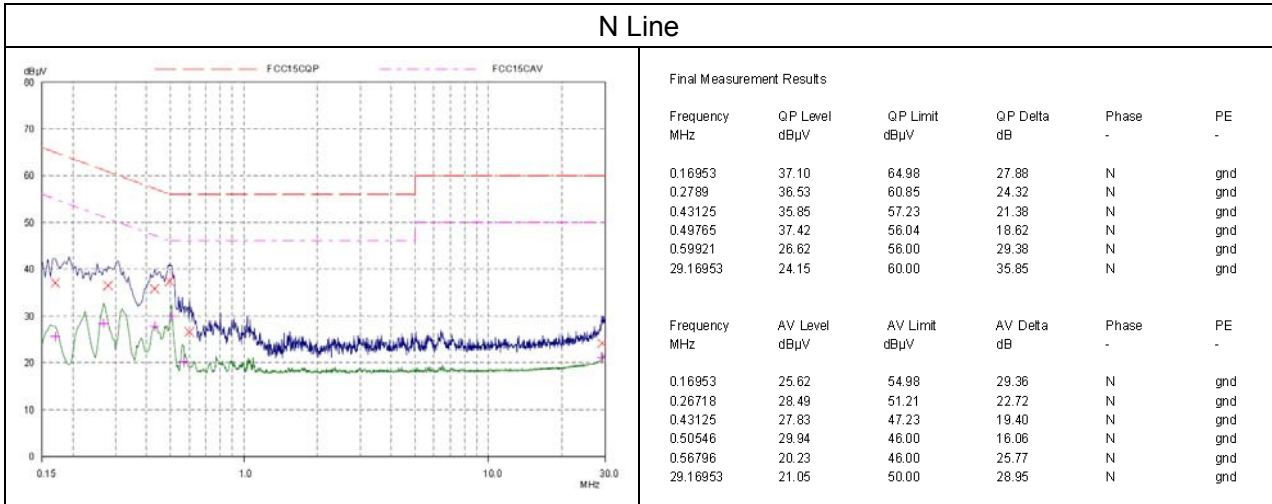

802.11n(HT40), Channel No.: 9

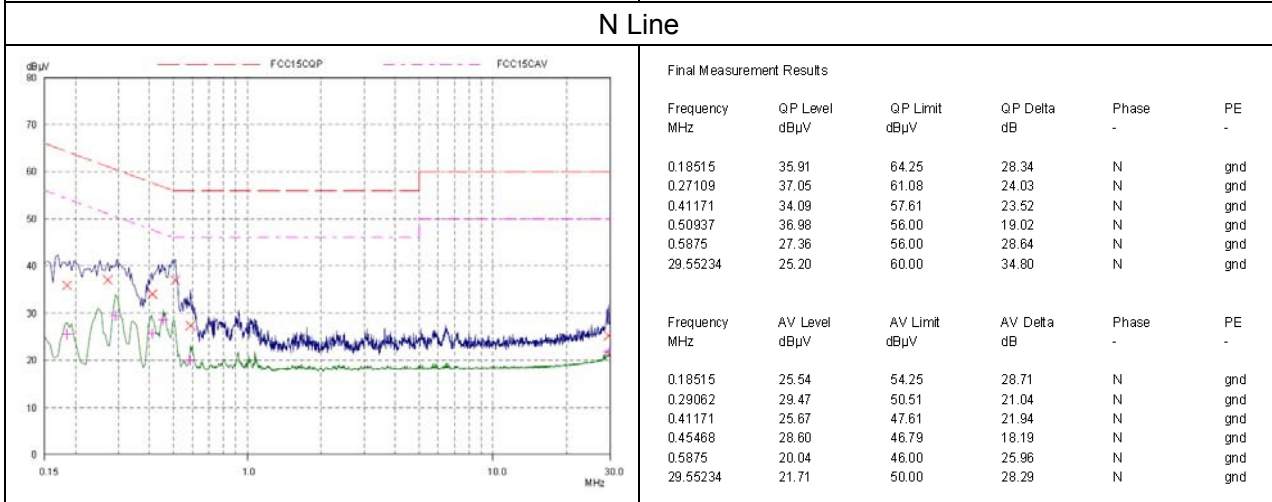
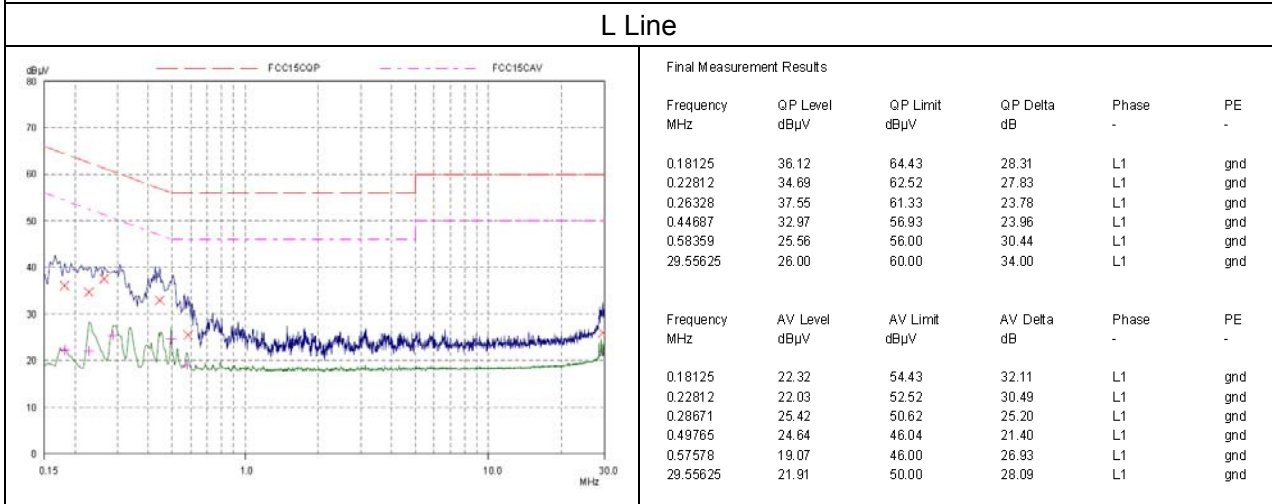

6. Main Test Instruments

Name	Type/Model	Manufacturer	Serial Number	Calibration Date	Expiration Time
Spectrum Analyzer	FSV30	R&S	100815	2015-12-17	2016-12-16
EMI Test Receiver	ESCI	R&S	100948	2016-06-01	2017-05-31
TRILOG Broadband Antenna	VULB 9163	Schwarzbeck	9163-201	2014-12-06	2017-12-05
Double Ridged Waveguide Horn Antenna	HF907	R&S	100126	2014-12-06	2017-12-05
Loop Antenna	FMZB1519	SCHWARZBECK	1519-047	2014-02-19	2017-02-18
Standard Gain Horn	3160-09	ETS-Lindgren	00102644	2015-01-30	2018-01-29
EMI Test Receiver	ESCS30	R&S	100138	2015-12-17	2016-12-16
LISN	ENV216	R&S	101171	2013-12-18	2016-12-17
Spectrum Analyzer	N9010A	Agilent	MY47191109	2016-05-21	2017-05-20
MOB COMMS DC SUPPLY	66319D	Agilent	MY43004105	2016-05-21	2017-05-20
Peak Power Meter	U2021XA	Keysight	MY55240003	2016-06-26	2017-06-25
RF Cable	SMA 15cm	Agilent	0001	2016-08-05	2016-10-04

*****END OF REPORT *****

ANNEX A: EUT Appearance and Test Setup

A.1 EUT Appearance



Front Side



Back Side

Picture 1-1: EUT



Picture 1-2: Adapter



Picture 1-3: Ethernet cables

Picture 1 EUT

A.2 Test Setup



30M Hz-1GHz

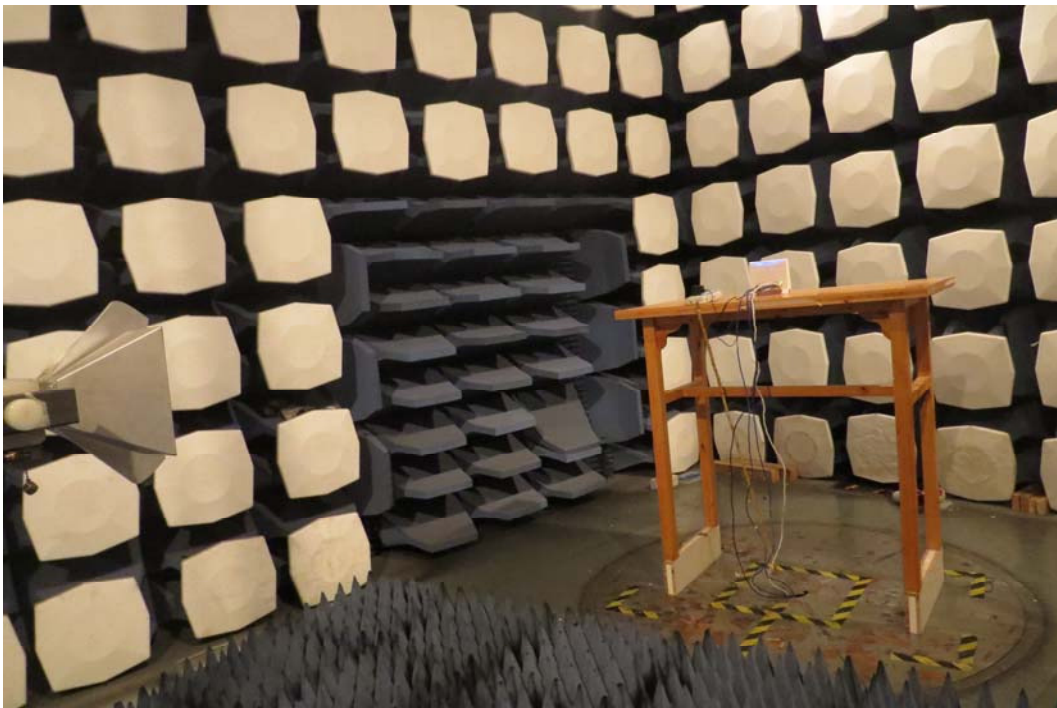

Above 1GHz

Picture 2 Radiated Emission Test Setup



Picture 3 Conducted Emission Test Setup