

802.11b CH11

RE 0.03-1GHz QP Class B

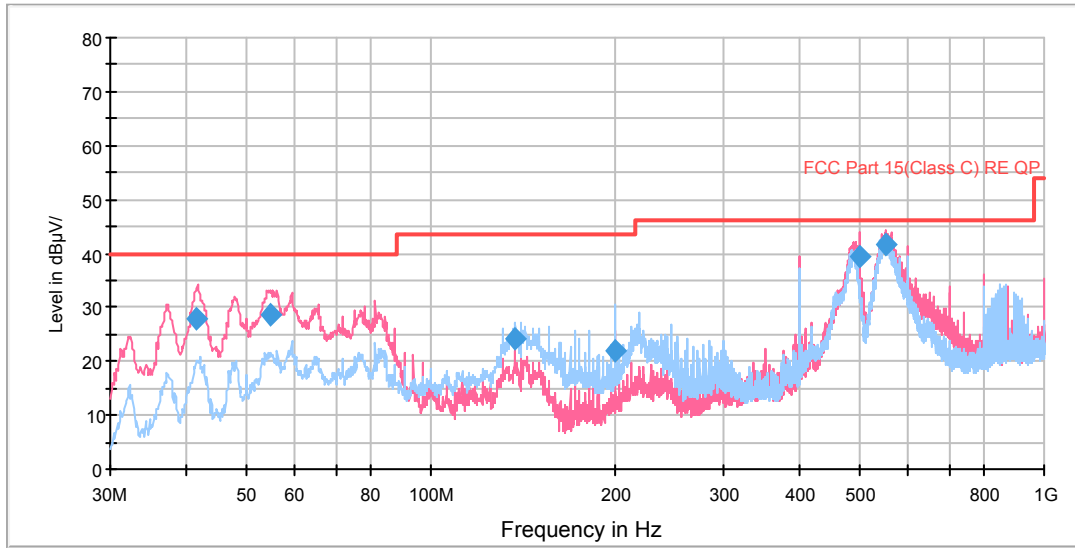

Radiates Emission from 30MHz to 1GHz

Frequency (MHz)	Quasi-Peak (dBuV/m)	Height (cm)	Polarization	Azimuth (deg)	Reading value (dBuV/m)	Correct Factor (dB)	Margin (dB)	Limit (dBuV/m)
41.580000	27.8	100.0	V	315.0	48.2	-20.4	12.2	40.0
54.876250	28.6	102.0	V	289.0	49.7	-21.1	11.4	40.0
137.488750	24.2	127.0	H	15.0	53.6	-29.4	19.3	43.5
199.931250	22.1	127.0	H	0.0	48.4	-26.3	21.4	43.5
499.985000	39.3	102.0	V	339.0	58.3	-19.0	6.7	46.0
553.617500	41.9	100.0	V	7.0	60.3	-18.4	4.1	46.0

- Remark: 1. Quasi-Peak = Reading value + Correction factor
 2. Correction Factor = Antenna factor+ Insertion loss(cable loss+amplifier gain)
 3. Margin = Limit – Quasi-Peak

RE 1G-3GHz PK+AV

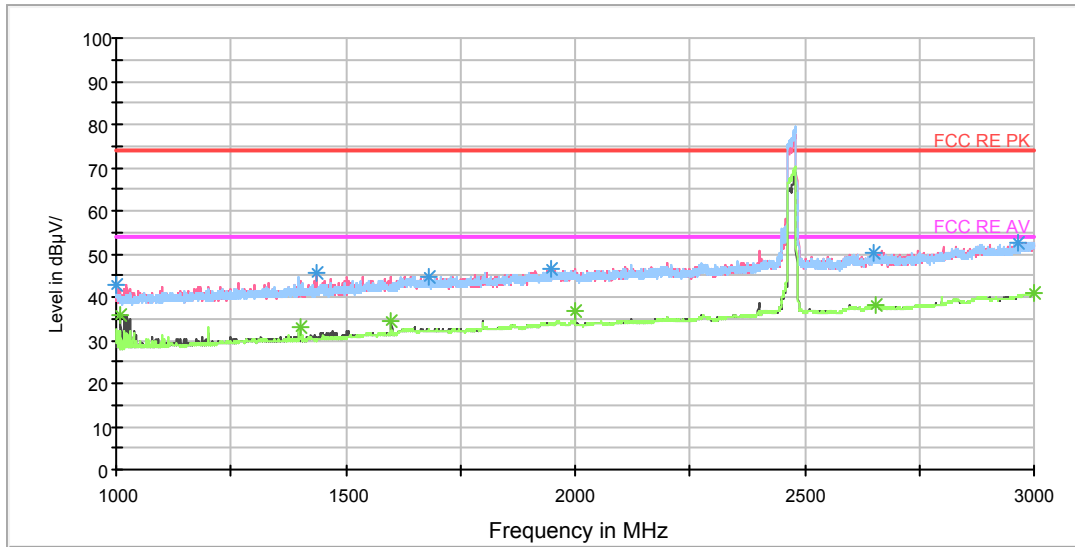

Note: The signal beyond the limit is carrier.

Radiates Emission from 1GHz to 3GHz

Frequency (MHz)	Peak (dBuV/m)	Height (cm)	Polarization	Azimuth (deg)	Reading value (dBuV/m)	Correct Factor (dB)	Margin (dB)	Limit (dBuV/m)
1000.000000	43.0	201.0	H	183.0	52.2	-9.2	31.0	74
1437.750000	45.4	101.0	V	141.0	52.3	-6.9	28.6	74
1682.500000	44.8	101.0	V	61.0	49.8	-5.0	29.2	74
1945.500000	46.6	101.0	V	200.0	49.9	-3.3	27.4	74
2648.750000	50.1	101.0	V	102.0	50.5	0.4	23.9	74
2966.750000	52.7	201.0	H	163.0	54.9	2.2	21.3	74

Remark: 1. Correction Factor = Antenna factor+ Insertion loss (cable loss + amplifier gain)

Frequency (MHz)	Average (dBuV/m)	Height (cm)	Polarization	Azimuth (deg)	Reading value (dBuV/m)	Correct Factor (dB)	Margin (dB)	Limit (dBuV/m)
1010.250000	35.8	201.0	V	46.0	45.1	-9.3	18.2	54
1399.750000	33.1	201.0	H	242.0	40.2	-7.1	20.9	54
1600.000000	34.5	101.0	V	0.0	40.9	-6.4	19.5	54
2000.000000	36.9	201.0	V	201.0	40.3	-3.4	17.1	54
2654.750000	38.0	101.0	V	0.0	38.4	0.4	16.0	54
3000.000000	41.0	201.0	V	46.0	43.3	2.3	13.0	54

Remark: 1. Correction Factor = Antenna factor+ Insertion loss (cable loss + amplifier gain)

RE 3-18GHz PK+AV

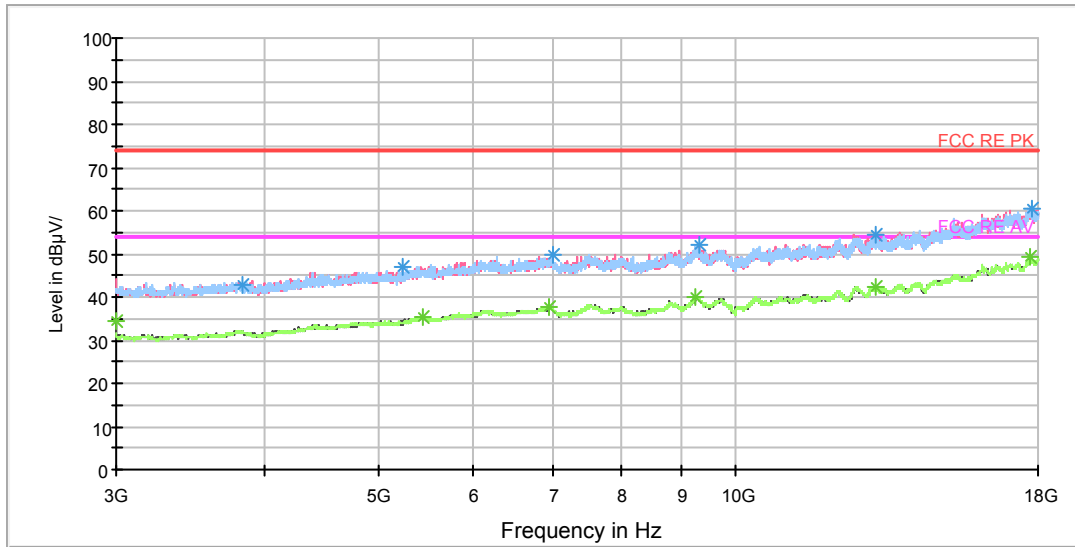

Radiates Emission from 3GHz to 18GHz

Frequency (MHz)	Peak (dBuV/m)	Height (cm)	Polarization	Azimuth (deg)	Reading value (dBuV/m)	Correct Factor (dB)	Margin (dB)	Limit (dBuV/m)
5238.750000	47.0	201.0	H	287.0	52.6	5.6	27.0	74
7006.875000	49.9	100.0	V	54.0	59.0	9.1	24.1	74
9303.750000	52.1	100.0	V	282.0	64.8	12.7	21.9	74
13123.125000	54.3	201.0	H	0.0	70.9	16.6	19.7	74
17805.000000	60.6	102.0	H	347.0	83.1	22.5	13.4	74
3838.125000	42.9	201.0	V	267.0	45.1	2.2	31.1	74

Remark: 1. Correction Factor = Antenna factor+ Insertion loss (cable loss + amplifier gain)

Frequency (MHz)	Average (dBuV/m)	Height (cm)	Polarization	Azimuth (deg)	Reading value (dBuV/m)	Correct Factor (dB)	Margin (dB)	Limit (dBuV/m)
3000.000000	34.6	201.0	V	347.0	35.0	0.4	19.4	54
5448.750000	35.4	100.0	V	282.0	41.8	6.4	18.6	54
6960.000000	37.7	201.0	H	323.0	46.7	9.0	16.3	54
9249.375000	39.9	100.0	V	167.0	52.6	12.7	14.1	54
13155.000000	42.4	201.0	H	287.0	59.0	16.6	11.6	54
17711.250000	49.3	102.0	H	66.0	71.7	22.4	4.7	54

Remark: 1. Correction Factor = Antenna factor+ Insertion loss (cable loss + amplifier gain)

RE 18-26.5GHz PK+AV

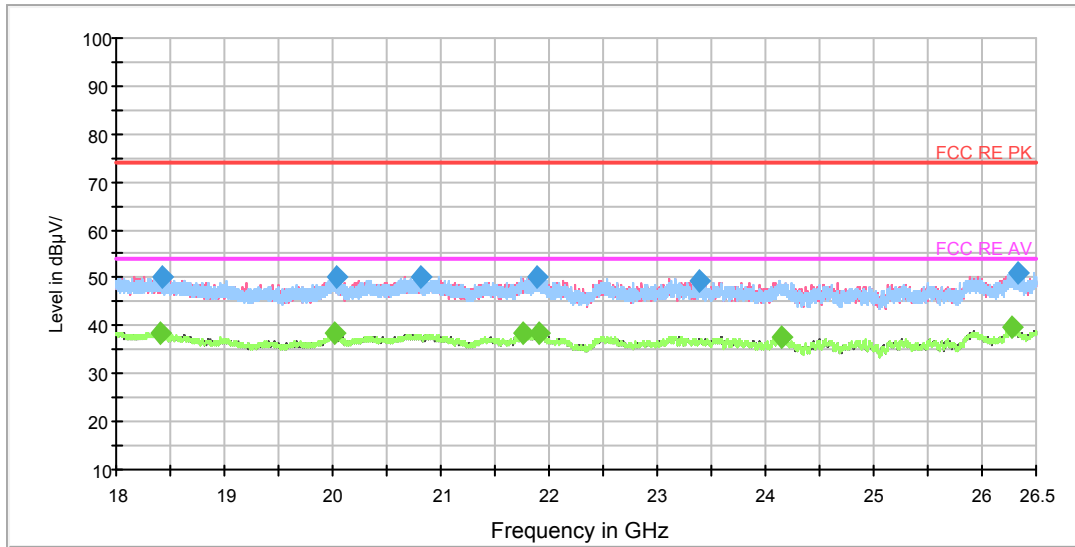

Radiates Emission from 18GHz to 26.5GHz

Frequency (MHz)	Peak (dBuV/m)	Polarization	Azimuth (deg)	Reading value (dBuV/m)	Correct Factor (dB)	Margin (dB)	Limit (dBuV/m)
18434.031250	50.2	H	0.0	53.8	-3.6	23.8	74.0
20033.625000	50.3	V	180.0	56.0	-5.7	23.7	74.0
20819.343750	50.3	H	0.0	57.3	-7.0	23.7	74.0
21884.500000	50.3	H	27.0	58.3	-8.0	23.7	74.0
23380.500000	49.3	H	27.0	55.2	-5.9	24.7	74.0
26324.156250	51.0	V	180.0	56.4	-5.4	23.0	74.0

Remark: 1. Correction Factor = Antenna factor+ Insertion loss (cable loss + amplifier gain)

Frequency (MHz)	Average (dBuV/m)	Polarization	Azimuth (deg)	Reading value (dBuV/m)	Correct Factor (dB)	Margin (dB)	Limit (dBuV/m)
18414.375000	38.6	H	14.0	42.1	-3.5	15.4	54.0
20021.406250	38.4	H	0.0	44.1	-5.7	15.6	54.0
21750.625000	38.4	V	150.0	46.4	-8.0	15.6	54.0
21912.656250	38.4	V	137.0	46.4	-8.0	15.6	54.0
24139.125000	37.8	H	138.0	43.7	-5.9	16.2	54.0
26277.937500	39.7	V	164.0	45.1	-5.4	14.3	54.0

Remark: 1. Correction Factor = Antenna factor+ Insertion loss (cable loss + amplifier gain)



802.11g CH1

RE 0.03-1GHz QP Class B

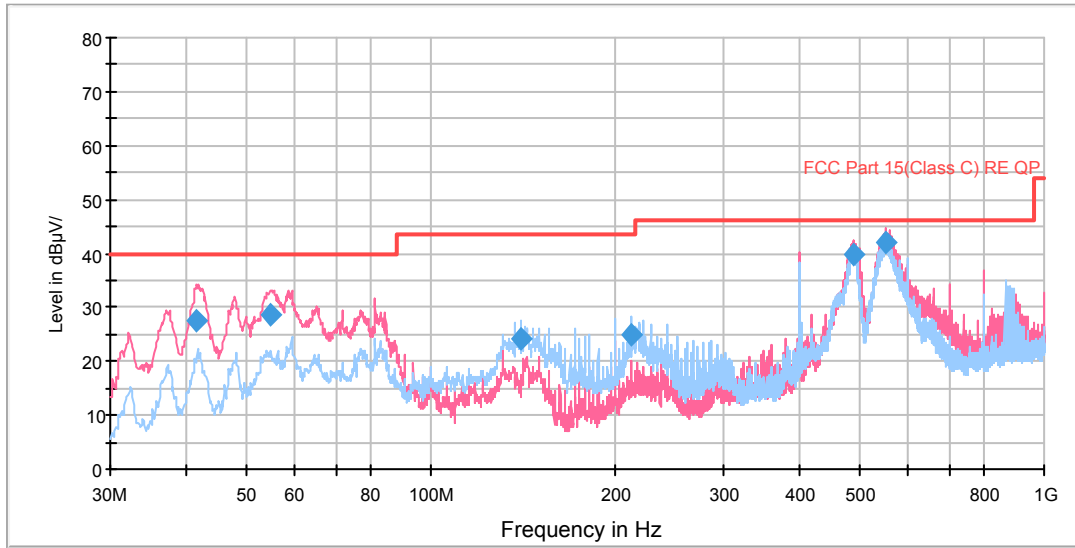

Radiates Emission from 30MHz to 1GHz

Frequency (MHz)	Quasi-Peak (dBuV/m)	Height (cm)	Polarization	Azimuth (deg)	Reading value (dBuV/m)	Correct Factor (dB)	Margin (dB)	Limit (dBuV/m)
41.578750	27.4	102.0	V	16.0	47.8	-20.4	12.6	40.0
54.957500	28.7	100.0	V	312.0	49.8	-21.1	11.3	40.0
140.640000	24.2	127.0	H	16.0	53.8	-29.6	19.3	43.5
212.501250	24.9	120.0	H	15.0	50.6	-25.7	18.6	43.5
490.245000	39.9	102.0	V	345.0	59.5	-19.6	6.1	46.0
549.980000	42.1	100.0	V	8.0	60.5	-18.4	3.9	46.0

- Remark: 1. Quasi-Peak = Reading value + Correction factor
 2. Correction Factor = Antenna factor+ Insertion loss(cable loss+amplifier gain)
 3. Margin = Limit – Quasi-Peak

RE 1G-3GHz PK+AV

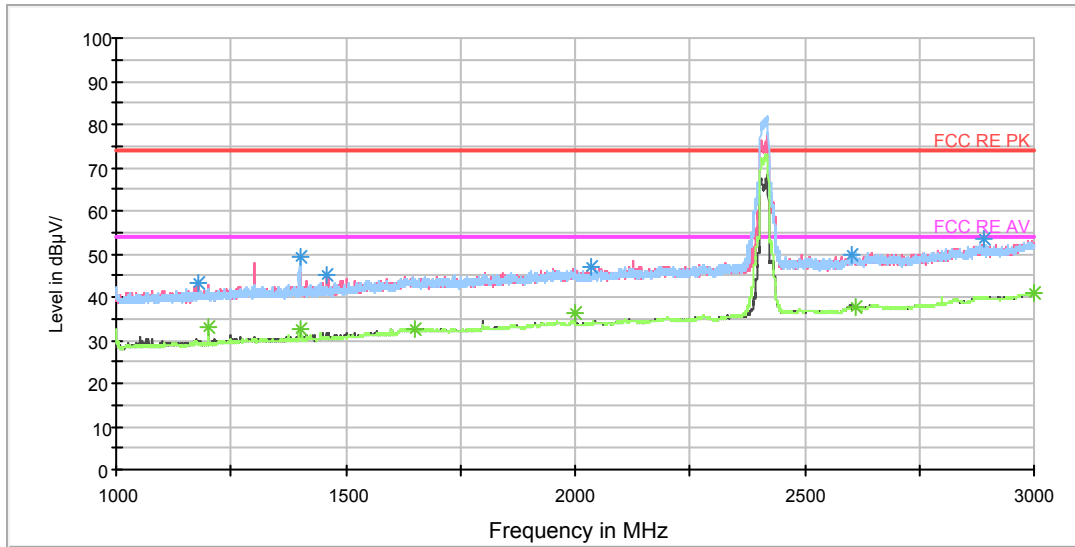

Note: The signal beyond the limit is carrier.

Radiates Emission from 1GHz to 3GHz

Frequency (MHz)	Peak (dBuV/m)	Height (cm)	Polarization	Azimuth (deg)	Reading value (dBuV/m)	Correct Factor (dB)	Margin (dB)	Limit (dBuV/m)
1177.250000	43.3	101.0	V	124.0	51.3	-8.0	30.7	74
1400.750000	49.3	201.0	H	237.0	56.4	-7.1	24.7	74
1460.000000	44.9	101.0	V	63.0	51.8	-6.9	29.1	74
2034.750000	46.8	201.0	H	100.0	50.1	-3.3	27.2	74
2601.250000	49.7	101.0	H	24.0	50.1	0.4	24.3	74
2890.750000	53.6	101.0	V	341.0	55.8	2.2	20.4	74

Remark: 1. Correction Factor = Antenna factor+ Insertion loss (cable loss + amplifier gain)

Frequency (MHz)	Average (dBuV/m)	Height (cm)	Polarization	Azimuth (deg)	Reading value (dBuV/m)	Correct Factor (dB)	Margin (dB)	Limit (dBuV/m)
1200.000000	33.0	201.0	H	218.0	41.2	-8.2	21.0	54
1400.000000	32.8	101.0	V	341.0	39.9	-7.1	21.2	54
1650.250000	32.8	101.0	V	0.0	37.9	-5.1	21.2	54
2000.000000	36.5	101.0	V	0.0	39.9	-3.4	17.5	54
2609.750000	37.7	101.0	H	62.0	37.9	0.2	16.3	54
2999.250000	41.1	101.0	V	0.0	43.4	2.3	12.9	54

Remark: 1. Correction Factor = Antenna factor+ Insertion loss (cable loss + amplifier gain)

RE 3-18GHz PK+AV

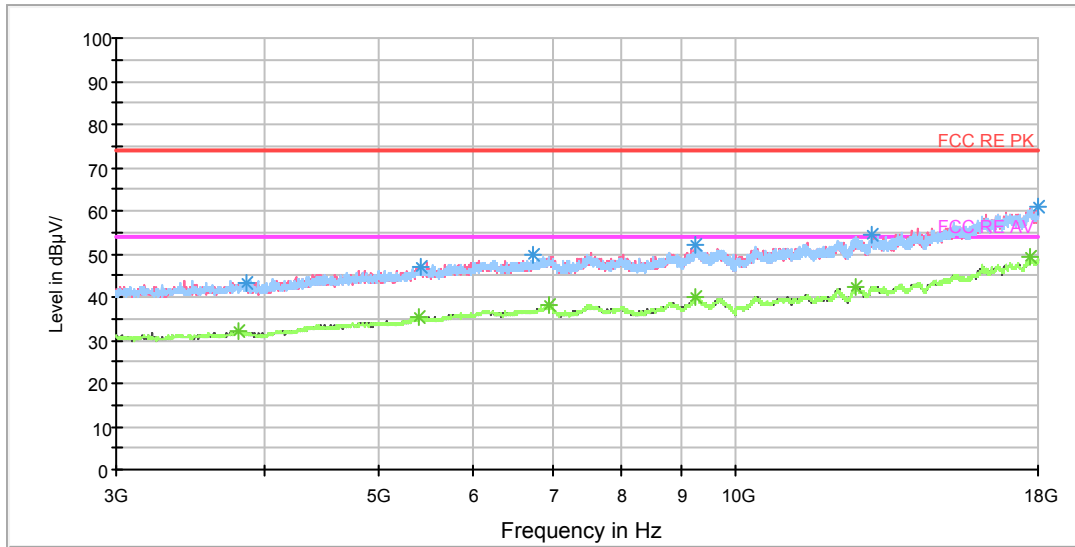

Radiates Emission from 3GHz to 18GHz

Frequency (MHz)	Peak (dBuV/m)	Height (cm)	Polarization	Azimuth (deg)	Reading value (dBuV/m)	Correct Factor (dB)	Margin (dB)	Limit (dBuV/m)
5422.500000	46.8	201.0	H	283.0	53.2	6.4	27.2	74
6736.875000	49.8	100.0	H	152.0	58.4	8.6	24.2	74
9232.500000	52.2	102.0	V	0.0	64.9	12.7	21.8	74
13021.875000	54.3	201.0	H	0.0	70.9	16.6	19.7	74
18000.000000	61.1	201.0	H	0.0	83.8	22.7	12.9	74
3864.375000	43.1	201.0	V	0.0	45.2	2.1	30.9	74

Remark: 1. Correction Factor = Antenna factor+ Insertion loss (cable loss + amplifier gain)

Frequency (MHz)	Average (dBuV/m)	Height (cm)	Polarization	Azimuth (deg)	Reading value (dBuV/m)	Correct Factor (dB)	Margin (dB)	Limit (dBuV/m)
3800.625000	32.1	201.0	H	60.0	34.2	2.1	21.9	54
5411.250000	35.5	100.0	H	0.0	41.9	6.4	18.5	54
6963.750000	38.0	100.0	H	0.0	47.0	9.0	16.0	54
9243.750000	39.9	201.0	H	0.0	52.6	12.7	14.1	54
12628.125000	42.5	201.0	H	98.0	58.2	15.7	11.5	54
17726.250000	49.2	102.0	V	259.0	71.6	22.4	4.8	54

Remark: 1. Correction Factor = Antenna factor+ Insertion loss (cable loss + amplifier gain)

RE 18-26.5GHz PK+AV

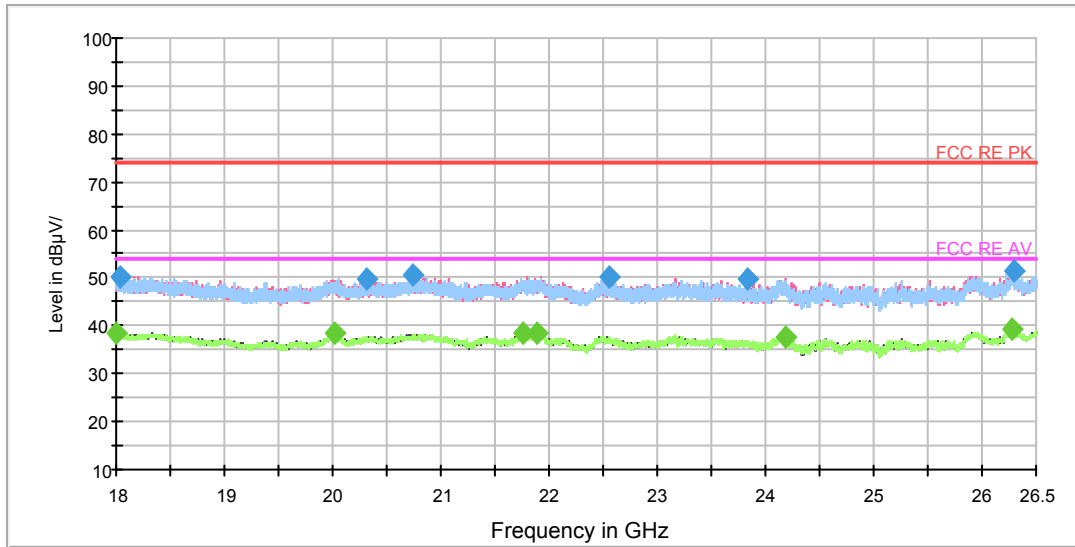

Radiates Emission from 18GHz to 26.5GHz

Frequency (MHz)	Peak (dBuV/m)	Polarization	Azimuth (deg)	Reading value (dBuV/m)	Correct Factor (dB)	Margin (dB)	Limit (dBuV/m)
18043.031250	50.2	H	82.0	52.2	-2.0	23.8	74.0
20310.406250	49.7	V	111.0	55.7	-6.0	24.3	74.0
20748.156250	50.5	V	111.0	57.3	-6.8	23.5	74.0
22553.343750	50.3	V	124.0	57.1	-6.8	23.7	74.0
23830.468750	49.7	V	111.0	55.6	-5.9	24.3	74.0
26289.625000	51.3	H	0.0	56.7	-5.4	22.7	74.0

Remark: 1. Correction Factor = Antenna factor+ Insertion loss (cable loss + amplifier gain)

Frequency (MHz)	Average (dBuV/m)	Polarization	Azimuth (deg)	Reading value (dBuV/m)	Correct Factor (dB)	Margin (dB)	Limit (dBuV/m)
18002.125000	38.7	H	0.0	40.5	-1.8	15.3	54.0
20022.468750	38.4	H	0.0	44.1	-5.7	15.6	54.0
21763.375000	38.4	H	55.0	46.4	-8.0	15.6	54.0
21895.125000	38.5	V	180.0	46.5	-8.0	15.5	54.0
24188.000000	37.8	H	2.0	43.7	-5.9	16.2	54.0
26274.750000	39.3	V	180.0	44.7	-5.4	14.7	54.0

Remark: 1. Correction Factor = Antenna factor+ Insertion loss (cable loss + amplifier gain)

802.11g CH6

RE 0.03-1GHz QP Class B

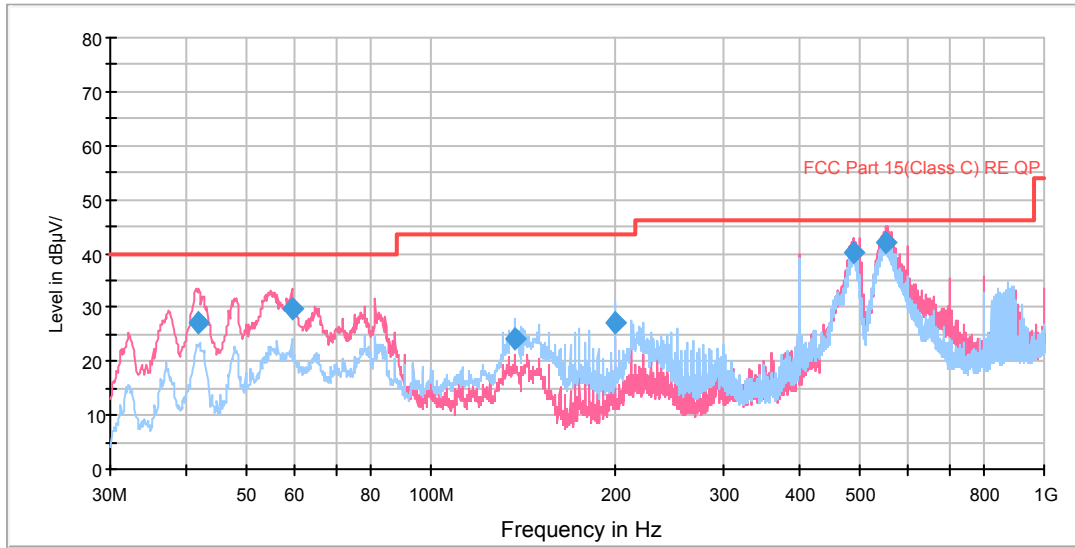

Radiates Emission from 30MHz to 1GHz

Frequency (MHz)	Quasi-Peak (dBuV/m)	Height (cm)	Polarization	Azimuth (deg)	Reading value (dBuV/m)	Correct Factor (dB)	Margin (dB)	Limit (dBuV/m)
41.701250	27.1	102.0	V	114.0	47.5	-20.4	12.9	40.0
59.362500	29.7	100.0	V	266.0	52.7	-23.0	10.3	40.0
137.487500	24.2	127.0	H	22.0	53.6	-29.4	19.3	43.5
200.012500	27.2	127.0	H	0.0	53.5	-26.3	16.3	43.5
487.860000	40.1	102.0	V	338.0	59.7	-19.6	5.9	46.0
551.557500	42.2	100.0	V	6.0	60.6	-18.4	3.8	46.0

- Remark:**
1. Quasi-Peak = Reading value + Correction factor
 2. Correction Factor = Antenna factor+ Insertion loss(cable loss+amplifier gain)
 3. Margin = Limit – Quasi-Peak

RE 1G-3GHz PK+AV

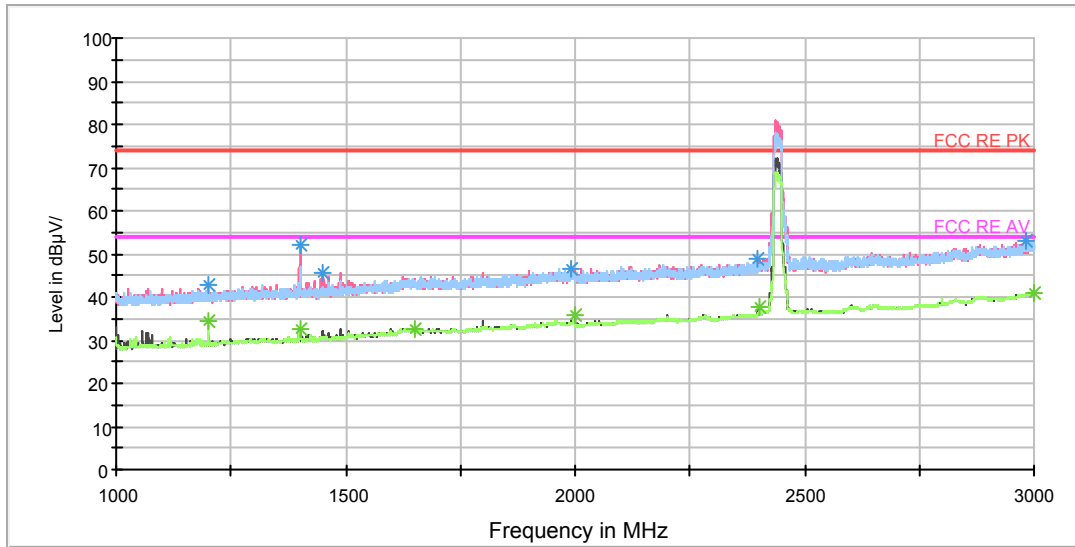

Note: The signal beyond the limit is carrier.
Radiates Emission from 1GHz to 3GHz

Frequency (MHz)	Peak (dBuV/m)	Height (cm)	Polarization	Azimuth (deg)	Reading value (dBuV/m)	Correct Factor (dB)	Margin (dB)	Limit (dBuV/m)
1199.750000	42.6	153.0	V	349.0	50.8	-8.2	31.4	74
1400.500000	51.9	153.0	V	349.0	59.0	-7.1	22.1	74
1448.250000	45.5	153.0	V	156.0	52.2	-6.7	28.5	74
1990.750000	46.7	153.0	H	0.0	50.0	-3.3	27.3	74
2399.250000	48.9	153.0	V	0.0	50.2	-1.3	25.1	74
2983.500000	53.1	153.0	H	62.0	55.3	2.2	20.9	74

Remark: 1. Correction Factor = Antenna factor+ Insertion loss (cable loss + amplifier gain)

Frequency (MHz)	Average (dBuV/m)	Height (cm)	Polarization	Azimuth (deg)	Reading value (dBuV/m)	Correct Factor (dB)	Margin (dB)	Limit (dBuV/m)
1200.000000	34.4	153.0	H	237.0	42.6	-8.2	19.6	54
1400.250000	32.7	153.0	V	21.0	39.8	-7.1	21.3	54
1649.750000	32.7	153.0	V	0.0	37.8	-5.1	21.3	54
2000.000000	36.0	153.0	V	0.0	39.4	-3.4	18.0	54
2400.500000	37.8	153.0	V	0.0	39.0	-1.2	16.2	54
2999.250000	41.0	153.0	V	0.0	43.3	2.3	13.0	54

Remark: 1. Correction Factor = Antenna factor+ Insertion loss (cable loss + amplifier gain)

RE 3-18GHz PK+AV

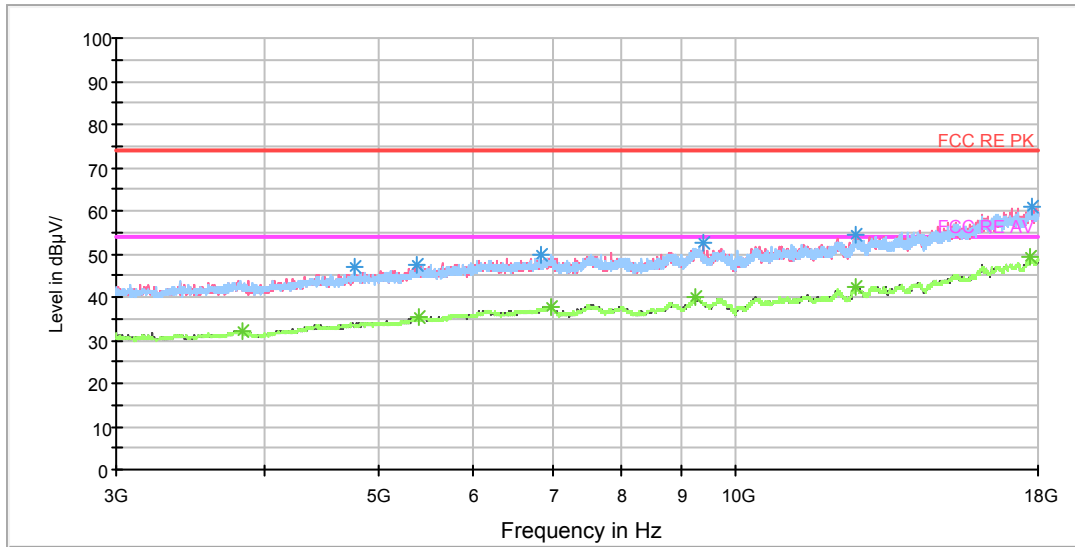

Radiates Emission from 3GHz to 18GHz

Frequency (MHz)	Peak (dBuV/m)	Height (cm)	Polarization	Azimuth (deg)	Reading value (dBuV/m)	Correct Factor (dB)	Margin (dB)	Limit (dBuV/m)
5371.875000	47.6	201.0	V	0.0	53.8	6.2	26.4	74
6856.875000	49.8	102.0	H	118.0	58.5	8.7	24.2	74
9378.750000	52.7	201.0	V	99.0	65.4	12.7	21.3	74
12603.750000	54.2	201.0	V	27.0	69.8	15.6	19.8	74
17801.250000	60.8	201.0	H	0.0	83.3	22.5	13.2	74
4760.625000	47.1	201.0	H	353.0	51.5	4.4	26.9	74

Remark: 1. Correction Factor = Antenna factor+ Insertion loss (cable loss + amplifier gain)

Frequency (MHz)	Average (dBuV/m)	Height (cm)	Polarization	Azimuth (deg)	Reading value (dBuV/m)	Correct Factor (dB)	Margin (dB)	Limit (dBuV/m)
3834.375000	32.2	201.0	V	154.0	34.4	2.2	21.8	54
5394.375000	35.3	100.0	V	0.0	41.6	6.3	18.7	54
6995.625000	37.8	201.0	H	263.0	46.9	9.1	16.2	54
9245.625000	40.0	201.0	H	190.0	52.7	12.7	14.0	54
12643.125000	42.4	201.0	V	0.0	58.1	15.7	11.6	54
17711.250000	49.2	201.0	V	27.0	71.6	22.4	4.8	54

Remark: 1. Correction Factor = Antenna factor+ Insertion loss (cable loss + amplifier gain)

RE 18-26.5GHz PK+AV

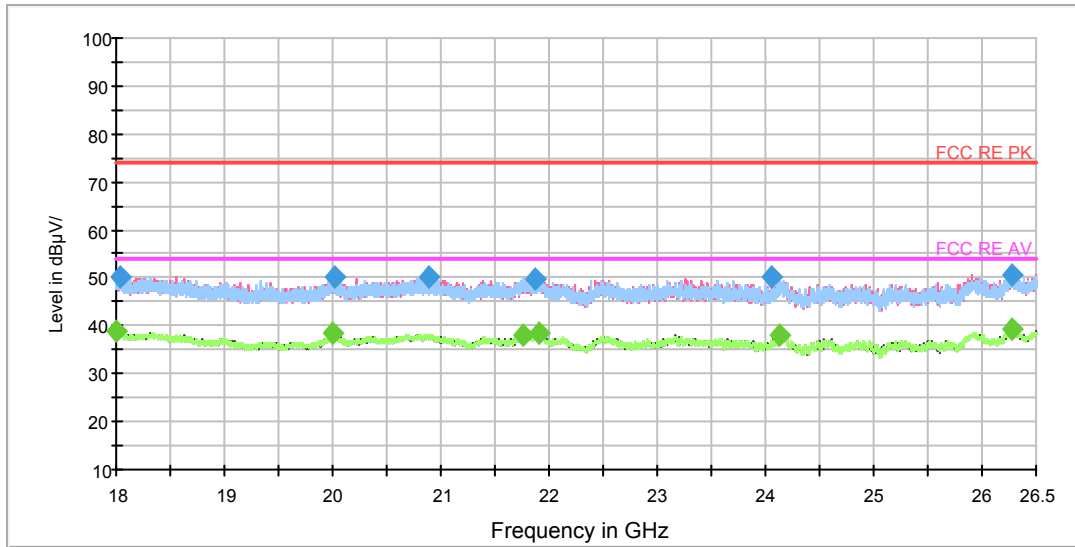

Radiates Emission from 18GHz to 26.5GHz

Frequency (MHz)	Peak (dBuV/m)	Polarization	Azimuth (deg)	Reading value (dBuV/m)	Correct Factor (dB)	Margin (dB)	Limit (dBuV/m)
18040.906250	50.2	V	69.0	52.2	-2.0	23.8	74.0
20011.312500	50.1	H	0.0	55.8	-5.7	23.9	74.0
20887.343750	50.2	H	82.0	57.3	-7.1	23.8	74.0
21869.093750	49.7	H	0.0	57.7	-8.0	24.3	74.0
24064.750000	50.3	V	124.0	56.2	-5.9	23.7	74.0
26280.593750	50.6	V	26.0	56.0	-5.4	23.4	74.0

Remark: 1. Correction Factor = Antenna factor+ Insertion loss (cable loss + amplifier gain)

Frequency (MHz)	Average (dBuV/m)	Polarization	Azimuth (deg)	Reading value (dBuV/m)	Correct Factor (dB)	Margin (dB)	Limit (dBuV/m)
18007.968750	38.7	H	96.0	40.5	-1.8	15.3	54.0
20006.531250	38.5	V	69.0	44.2	-5.7	15.5	54.0
21759.656250	38.2	H	55.0	46.2	-8.0	15.8	54.0
21912.125000	38.4	H	0.0	46.4	-8.0	15.6	54.0
24126.906250	37.9	V	180.0	43.8	-5.9	16.1	54.0
26275.812500	39.2	H	16.0	44.6	-5.4	14.8	54.0

Remark: 1. Correction Factor = Antenna factor+ Insertion loss (cable loss + amplifier gain)



802.11g CH11

RE 0.03-1GHz QP Class B

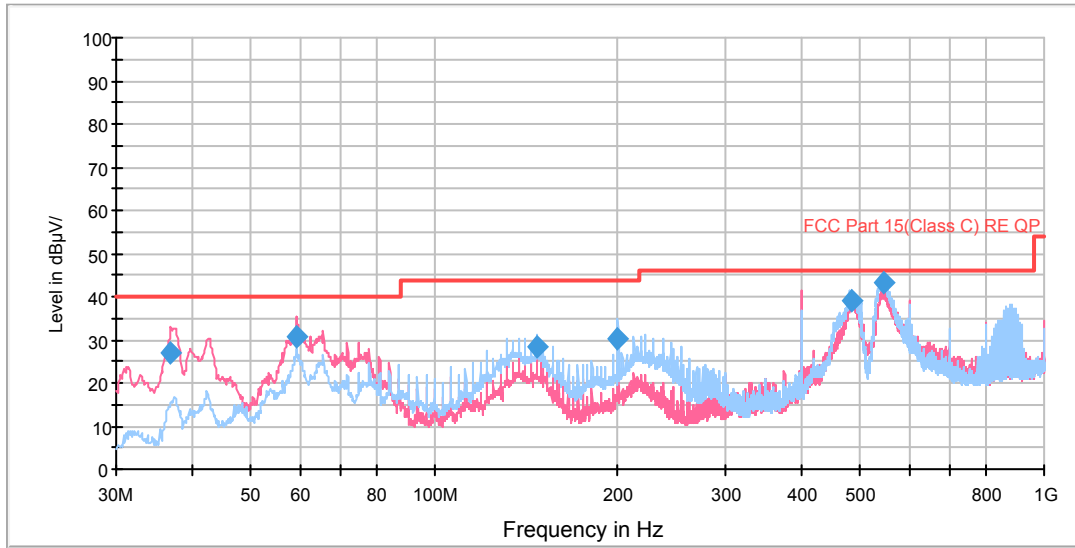

Radiates Emission from 30MHz to 1GHz

Frequency (MHz)	Quasi-Peak (dBuV/m)	Height (cm)	Polarization	Azimuth (deg)	Reading value (dBuV/m)	Correct Factor (dB)	Margin (dB)	Limit (dBuV/m)
36.931250	27.1	102.0	V	136.0	49.2	-22.1	12.9	40.0
59.362500	30.8	100.0	V	247.0	53.8	-23.0	9.2	40.0
146.865000	28.5	221.0	H	115.0	58.1	-29.6	15.0	43.5
199.972500	30.4	127.0	H	271.0	56.7	-26.3	13.1	43.5
484.586250	38.9	100.0	H	0.0	58.4	-19.5	7.1	46.0
543.756250	43.2	102.0	H	0.0	61.5	-18.3	2.8	46.0

- Remark: 1. Quasi-Peak = Reading value + Correction factor
 2. Correction Factor = Antenna factor+ Insertion loss(cable loss+amplifier gain)
 3. Margin = Limit – Quasi-Peak

RE 1G-3GHz PK+AV

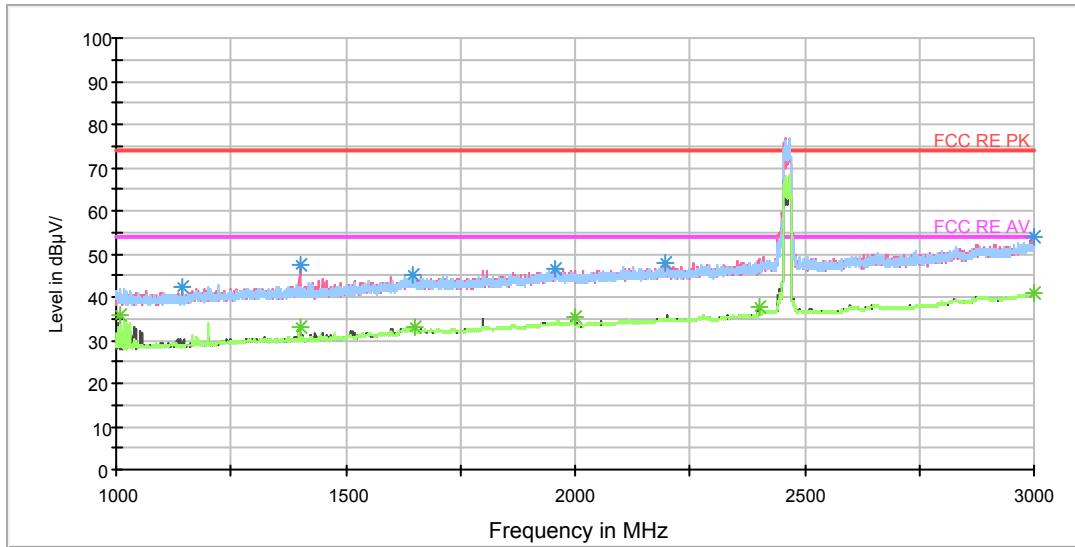

Note: The signal beyond the limit is carrier.
Radiates Emission from 1GHz to 3GHz

Frequency (MHz)	Peak (dBuV/m)	Height (cm)	Polarization	Azimuth (deg)	Reading value (dBuV/m)	Correct Factor (dB)	Margin (dB)	Limit (dBuV/m)
1144.000000	42.1	153.0	V	122.0	50.6	-8.5	31.9	74
1400.250000	47.6	153.0	V	0.0	54.7	-7.1	26.4	74
1644.250000	45.3	153.0	H	0.0	50.1	-4.8	28.7	74
1957.750000	46.6	153.0	V	122.0	49.9	-3.3	27.4	74
2197.750000	48.0	153.0	V	297.0	50.1	-2.1	26.0	74
2998.500000	54.0	153.0	H	0.0	56.3	2.3	20.0	74

Remark: 1. Correction Factor = Antenna factor+ Insertion loss (cable loss + amplifier gain)

Frequency (MHz)	Average (dBuV/m)	Height (cm)	Polarization	Azimuth (deg)	Reading value (dBuV/m)	Correct Factor (dB)	Margin (dB)	Limit (dBuV/m)
1010.250000	35.7	153.0	H	0.0	45.0	-9.3	18.3	54
1400.250000	33.1	153.0	V	0.0	40.2	-7.1	20.9	54
1649.750000	33.0	153.0	V	0.0	38.1	-5.1	21.0	54
2000.000000	35.6	153.0	V	160.0	39.0	-3.4	18.4	54
2400.250000	37.6	153.0	V	19.0	38.8	-1.2	16.4	54
2999.000000	41.0	153.0	V	200.0	43.3	2.3	13.0	54

Remark: 1. Correction Factor = Antenna factor+ Insertion loss (cable loss + amplifier gain)



RE 3-18GHz PK+AV

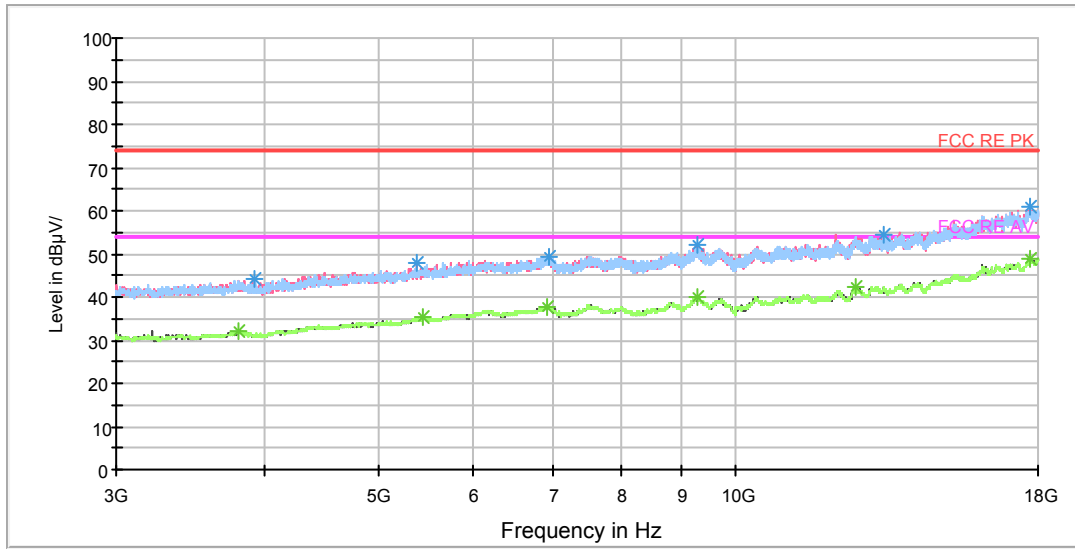

Radiates Emission from 3GHz to 18GHz

Frequency (MHz)	Peak (dBuV/m)	Height (cm)	Polarization	Azimuth (deg)	Reading value (dBuV/m)	Correct Factor (dB)	Margin (dB)	Limit (dBuV/m)
3931.875000	44.1	201.0	H	300.0	46.1	2.0	29.9	74
5379.375000	48.0	102.0	V	244.0	54.3	6.3	26.0	74
6958.125000	49.5	100.0	H	65.0	58.5	9.0	24.5	74
9277.500000	52.3	201.0	V	5.0	65.0	12.7	21.7	74
13346.250000	54.6	201.0	H	300.0	71.0	16.4	19.4	74
17730.000000	60.9	100.0	H	137.0	83.3	22.4	13.1	74

Remark: 1. Correction Factor = Antenna factor+ Insertion loss (cable loss + amplifier gain)

Frequency (MHz)	Average (dBuV/m)	Height (cm)	Polarization	Azimuth (deg)	Reading value (dBuV/m)	Correct Factor (dB)	Margin (dB)	Limit (dBuV/m)
3800.625000	32.1	100.0	H	26.0	34.2	2.1	21.9	54
5439.375000	35.3	201.0	H	353.0	41.7	6.4	18.7	54
6941.250000	37.7	201.0	H	317.0	46.6	8.9	16.3	54
9294.375000	39.8	102.0	V	0.0	52.5	12.7	14.2	54
12645.000000	42.4	201.0	V	136.0	58.1	15.7	11.6	54
17715.000000	49.0	201.0	V	5.0	71.4	22.4	5.0	54

Remark: 1. Correction Factor = Antenna factor+ Insertion loss (cable loss + amplifier gain)

RE 18-26.5GHz PK+AV

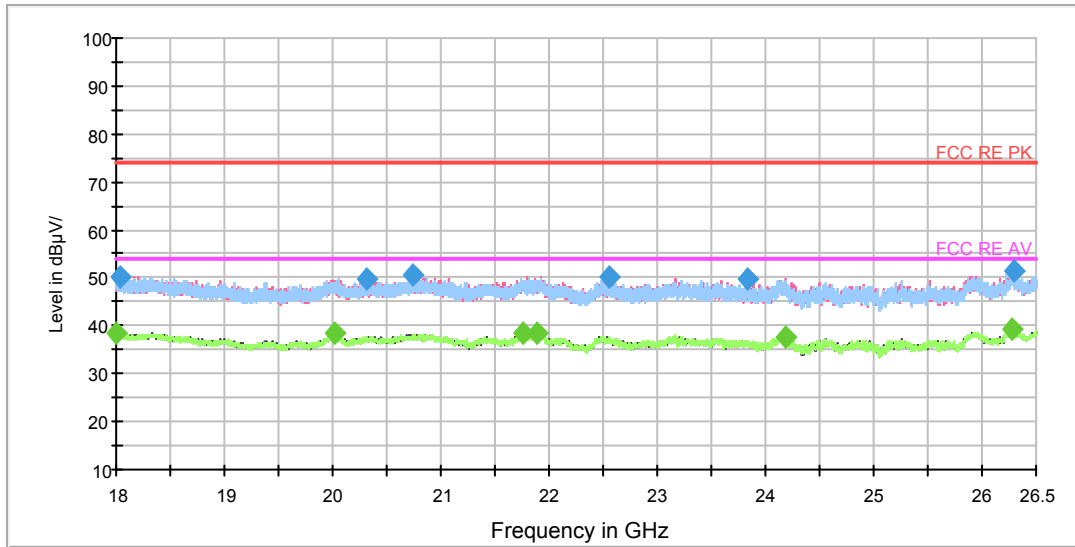

Radiates Emission from 18GHz to 26.5GHz

Frequency (MHz)	Peak (dBuV/m)	Polarization	Azimuth (deg)	Reading value (dBuV/m)	Correct Factor (dB)	Margin (dB)	Limit (dBuV/m)
18043.031250	50.2	H	82.0	52.2	-2.0	23.8	74.0
20310.406250	49.7	V	111.0	55.7	-6.0	24.3	74.0
20748.156250	50.5	V	111.0	57.3	-6.8	23.5	74.0
22553.343750	50.3	V	124.0	57.1	-6.8	23.7	74.0
23830.468750	49.7	V	111.0	55.6	-5.9	24.3	74.0
26289.625000	51.3	H	0.0	56.7	-5.4	22.7	74.0

Remark: 1. Correction Factor = Antenna factor+ Insertion loss (cable loss + amplifier gain)

Frequency (MHz)	Average (dBuV/m)	Polarization	Azimuth (deg)	Reading value (dBuV/m)	Correct Factor (dB)	Margin (dB)	Limit (dBuV/m)
18002.125000	38.7	H	0.0	40.5	-1.8	15.3	54.0
20022.468750	38.4	H	0.0	44.1	-5.7	15.6	54.0
21763.375000	38.4	H	55.0	46.4	-8.0	15.6	54.0
21895.125000	38.5	V	180.0	46.5	-8.0	15.5	54.0
24188.000000	37.8	H	2.0	43.7	-5.9	16.2	54.0
26274.750000	39.3	V	180.0	44.7	-5.4	14.7	54.0

Remark: 1. Correction Factor = Antenna factor+ Insertion loss (cable loss + amplifier gain)



MIMO

802.11n (HT20) CH1

RE 0.03-1GHz QP Class B

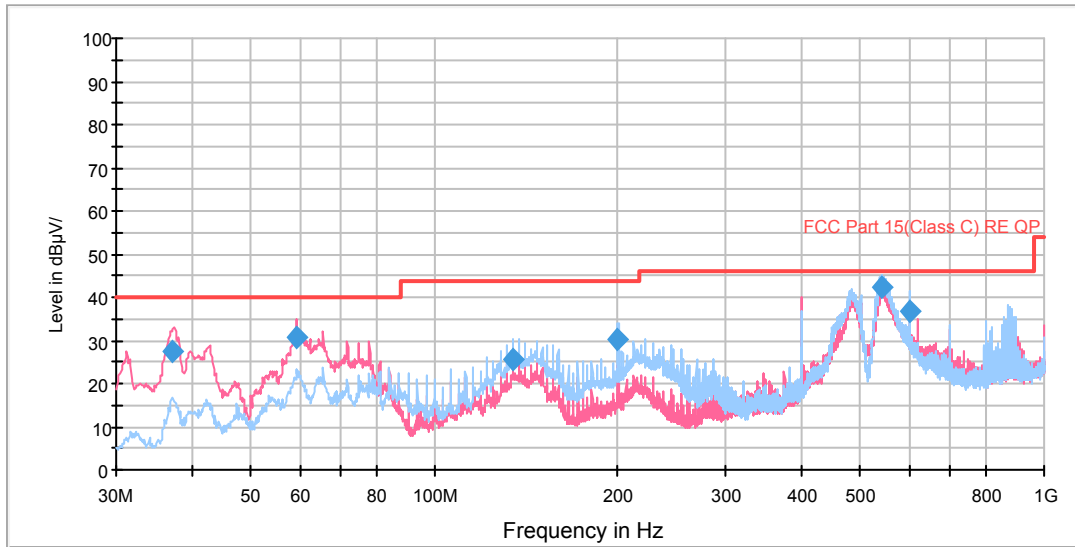

Radiates Emission from 30MHz to 1GHz

Frequency (MHz)	Quasi-Peak (dBuV/m)	Height (cm)	Polarization	Azimuth (deg)	Reading value (dBuV/m)	Correct Factor (dB)	Margin (dB)	Limit (dBuV/m)
37.215000	27.7	100.0	V	87.0	49.8	-22.1	12.3	40.0
59.362500	30.5	102.0	V	263.0	53.5	-23.0	9.5	40.0
134.335000	25.6	197.0	H	321.0	54.7	-29.1	17.9	43.5
199.972500	30.4	177.0	H	256.0	56.7	-26.3	13.1	43.5
540.645000	42.4	100.0	H	6.0	60.7	-18.3	3.6	46.0
600.016250	36.8	197.0	H	7.0	53.7	-16.9	9.2	46.0

- Remark: 1. Quasi-Peak = Reading value + Correction factor
 2. Correction Factor = Antenna factor+ Insertion loss(cable loss+amplifier gain)
 3. Margin = Limit – Quasi-Peak

RE 1G-3GHz PK+AV

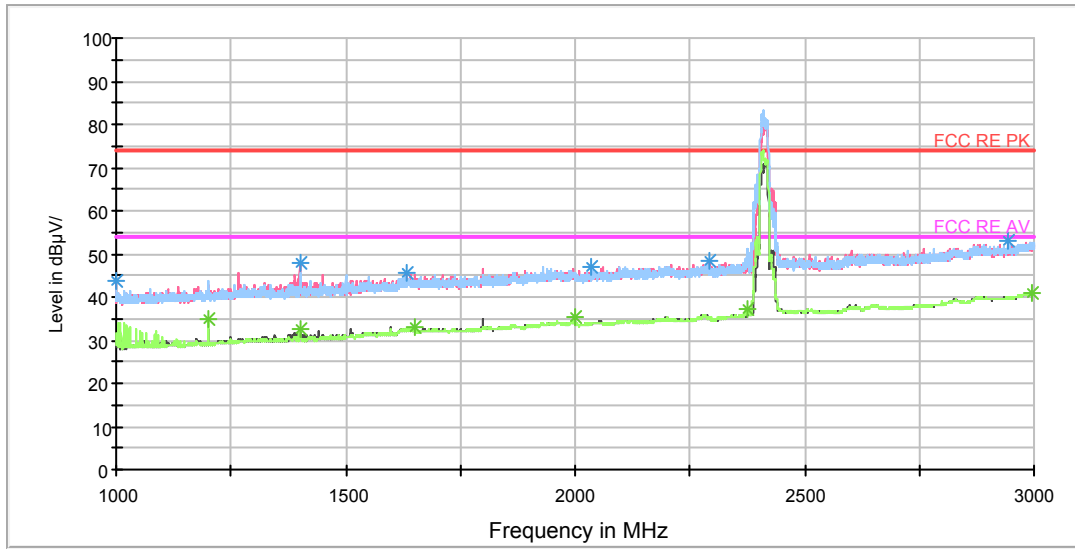

Note: The signal beyond the limit is carrier.
Radiates Emission from 1GHz to 3GHz

Frequency (MHz)	Peak (dBuV/m)	Height (cm)	Polarization	Azimuth (deg)	Reading value (dBuV/m)	Correct Factor (dB)	Margin (dB)	Limit (dBuV/m)
1000.000000	43.9	202.0	V	4.0	53.1	-9.2	30.1	74
1399.750000	48.1	103.0	V	353.0	55.2	-7.1	25.9	74
1631.250000	45.7	202.0	V	4.0	50.4	-4.7	28.3	74
2036.500000	47.1	202.0	H	102.0	50.4	-3.3	26.9	74
2294.750000	48.1	103.0	V	60.0	50.1	-2.0	25.9	74
2942.000000	52.8	202.0	V	0.0	54.7	1.9	21.2	74

Remark: 1. Correction Factor = Antenna factor+ Insertion loss (cable loss + amplifier gain)

Frequency (MHz)	Average (dBuV/m)	Height (cm)	Polarization	Azimuth (deg)	Reading value (dBuV/m)	Correct Factor (dB)	Margin (dB)	Limit (dBuV/m)
1200.000000	34.7	202.0	H	262.0	42.9	-8.2	19.3	54
1400.250000	32.5	202.0	H	241.0	39.6	-7.1	21.5	54
1650.750000	32.9	202.0	V	0.0	38.0	-5.1	21.1	54
2000.250000	35.6	202.0	V	4.0	39.0	-3.4	18.4	54
2375.500000	37.2	202.0	H	281.0	38.7	-1.5	16.8	54
2996.750000	41.0	103.0	H	259.0	43.3	2.3	13.0	54

Remark: 1. Correction Factor = Antenna factor+ Insertion loss (cable loss + amplifier gain)



RE 3-18GHz PK+AV

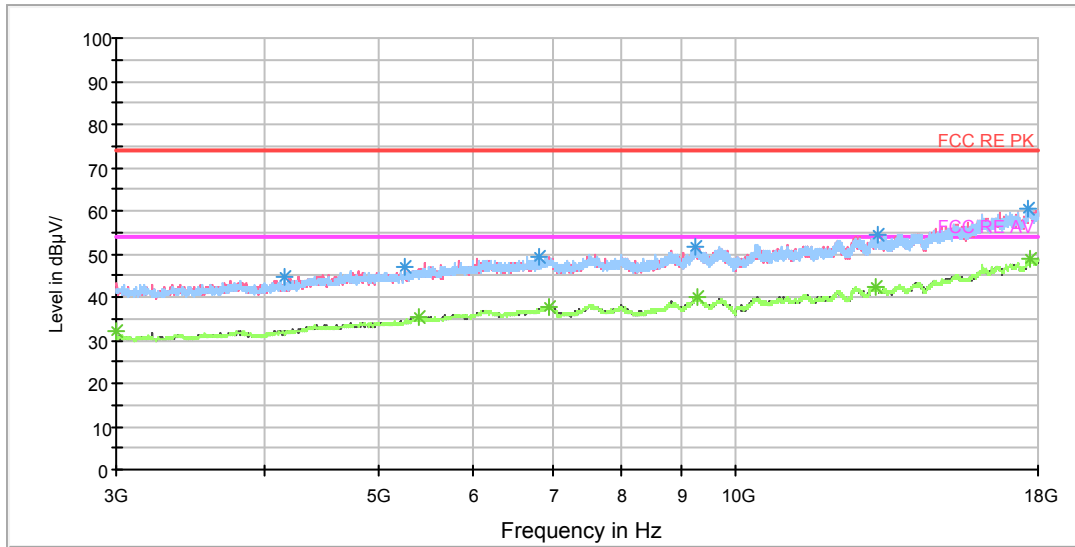

Radiates Emission from 3GHz to 18GHz

Frequency (MHz)	Peak (dBuV/m)	Height (cm)	Polarization	Azimuth (deg)	Reading value (dBuV/m)	Correct Factor (dB)	Margin (dB)	Limit (dBuV/m)
5266.875000	46.9	201.0	V	80.0	52.6	5.7	27.1	74
6836.250000	49.4	201.0	V	305.0	58.1	8.7	24.6	74
9255.000000	51.6	102.0	H	0.0	64.3	12.7	22.4	74
13181.250000	54.5	201.0	V	154.0	71.0	16.5	19.5	74
17685.000000	60.6	102.0	H	0.0	83.0	22.4	13.4	74
4160.625000	44.8	201.0	H	0.0	47.7	2.9	29.2	74

Remark: 1. Correction Factor = Antenna factor+ Insertion loss (cable loss + amplifier gain)

Frequency (MHz)	Average (dBuV/m)	Height (cm)	Polarization	Azimuth (deg)	Reading value (dBuV/m)	Correct Factor (dB)	Margin (dB)	Limit (dBuV/m)
3000.000000	32.3	201.0	V	43.0	32.7	0.4	21.7	54
5411.250000	35.2	100.0	V	205.0	41.6	6.4	18.8	54
6956.250000	37.8	100.0	V	223.0	46.8	9.0	16.2	54
9277.500000	40.0	201.0	H	351.0	52.7	12.7	14.0	54
13140.000000	42.3	201.0	V	62.0	58.9	16.6	11.7	54
17718.750000	48.9	100.0	V	186.0	71.3	22.4	5.1	54

Remark: 1. Correction Factor = Antenna factor+ Insertion loss (cable loss + amplifier gain)

RE 18-26.5GHz PK+AV

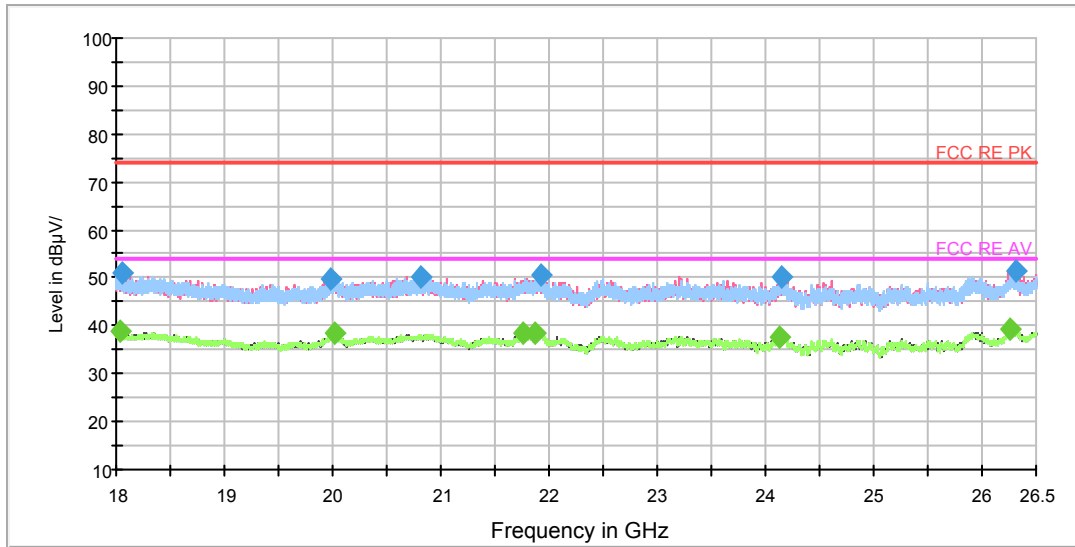

Radiates Emission from 18GHz to 26.5GHz

Frequency (MHz)	Peak (dBuV/m)	Polarization	Azimuth (deg)	Reading value (dBuV/m)	Correct Factor (dB)	Margin (dB)	Limit (dBuV/m)
18055.250000	51.1	V	126.0	53.1	-2.0	22.9	74.0
19987.937500	49.9	V	178.0	55.6	-5.7	24.1	74.0
20808.718750	50.2	H	96.0	57.2	-7.0	23.8	74.0
21916.906250	50.6	H	80.0	58.6	-8.0	23.4	74.0
24143.375000	50.0	H	28.0	55.9	-5.9	24.0	74.0
26307.687500	51.3	V	86.0	56.7	-5.4	22.7	74.0

Remark: 1. Correction Factor = Antenna factor+ Insertion loss (cable loss + amplifier gain)

Frequency (MHz)	Average (dBuV/m)	Polarization	Azimuth (deg)	Reading value (dBuV/m)	Correct Factor (dB)	Margin (dB)	Limit (dBuV/m)
18046.218750	38.8	V	165.0	40.8	-2.0	15.2	54.0
20026.718750	38.3	V	126.0	44.0	-5.7	15.7	54.0
21759.656250	38.6	H	80.0	46.6	-8.0	15.4	54.0
21875.468750	38.5	H	153.0	46.5	-8.0	15.5	54.0
24130.093750	37.8	H	0.0	43.7	-5.9	16.2	54.0
26265.187500	39.4	H	41.0	44.8	-5.4	14.6	54.0

Remark: 1. Correction Factor = Antenna factor+ Insertion loss (cable loss + amplifier gain)

802.11n (HT20) CH6

RE 0.03-1GHz QP Class B

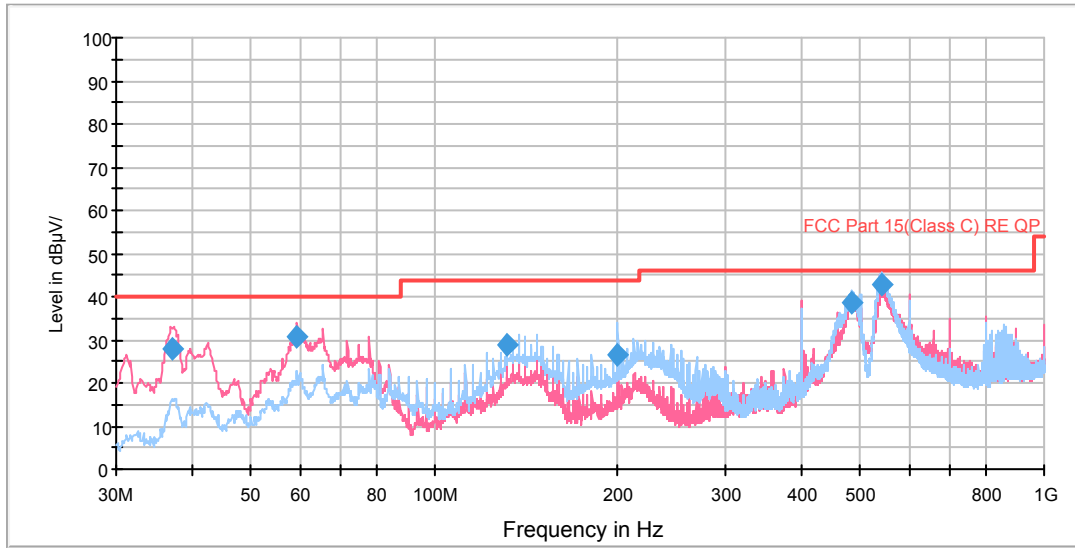

Radiates Emission from 30MHz to 1GHz

Frequency (MHz)	Quasi-Peak (dBuV/m)	Height (cm)	Polarization	Azimuth (deg)	Reading value (dBuV/m)	Correct Factor (dB)	Margin (dB)	Limit (dBuV/m)
37.215000	27.7	103.0	V	88.0	49.8	-22.1	12.3	40.0
59.362500	30.6	100.0	V	261.0	53.6	-23.0	9.4	40.0
131.263750	29.0	177.0	H	305.0	57.8	-28.8	14.5	43.5
199.931250	26.7	197.0	H	248.0	53.0	-26.3	16.8	43.5
484.586250	38.6	102.0	H	16.0	58.1	-19.5	7.4	46.0
540.038750	42.8	101.0	H	0.0	61.1	-18.3	3.2	46.0

- Remark: 1. Quasi-Peak = Reading value + Correction factor
 2. Correction Factor = Antenna factor+ Insertion loss(cable loss+amplifier gain)
 3. Margin = Limit – Quasi-Peak

RE 1G-3GHz PK+AV

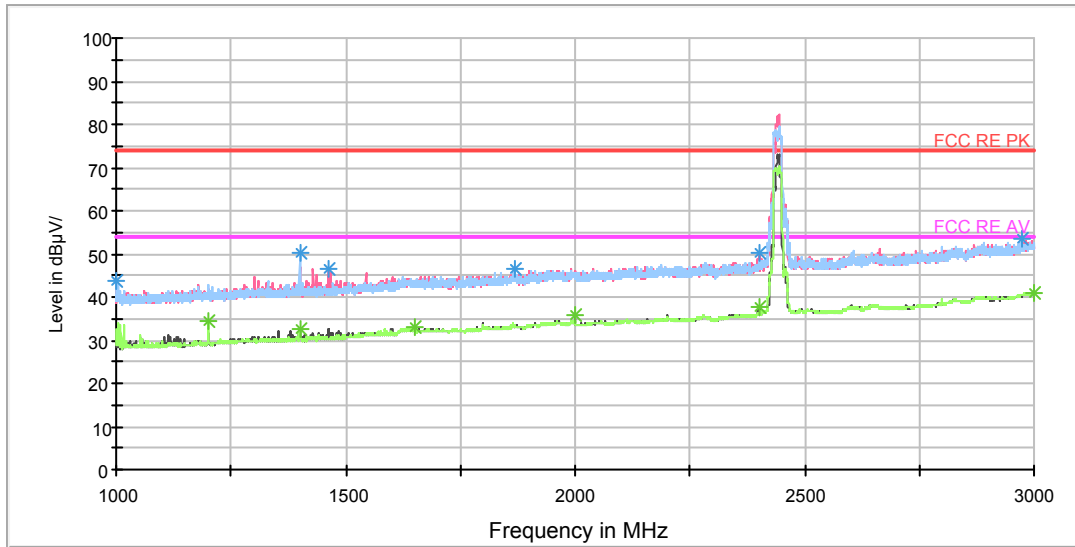

Note: The signal beyond the limit is carrier.

Radiates Emission from 1GHz to 3GHz

Frequency (MHz)	Peak (dBuV/m)	Height (cm)	Polarization	Azimuth (deg)	Reading value (dBuV/m)	Correct Factor (dB)	Margin (dB)	Limit (dBuV/m)
1000.250000	43.8	202.0	H	238.0	53.0	-9.2	30.2	74.0
1399.750000	50.2	103.0	H	219.0	57.3	-7.1	23.8	74.0
1461.000000	46.4	103.0	V	257.0	53.3	-6.9	27.6	74.0
1869.000000	46.7	202.0	H	0.0	50.4	-3.7	27.3	74.0
2400.000000	50.2	103.0	V	0.0	51.4	-1.2	23.8	74.0
2973.500000	53.3	202.0	H	0.0	55.5	2.2	20.7	74.0

Remark: 1. Correction Factor = Antenna factor+ Insertion loss (cable loss + amplifier gain)

Frequency (MHz)	Average (dBuV/m)	Height (cm)	Polarization	Azimuth (deg)	Reading value (dBuV/m)	Correct Factor (dB)	Margin (dB)	Limit (dBuV/m)
1200.000000	34.6	202.0	H	257.0	42.8	-8.2	19.4	54
1399.750000	32.5	202.0	H	238.0	39.6	-7.1	21.5	54
1650.250000	32.8	202.0	V	0.0	37.9	-5.1	21.2	54
2000.000000	35.7	202.0	V	0.0	39.1	-3.4	18.3	54
2400.000000	37.8	202.0	V	0.0	39.0	-1.2	16.2	54
2999.250000	41.1	103.0	H	279.0	43.4	2.3	12.9	54

Remark: 1. Correction Factor = Antenna factor+ Insertion loss (cable loss + amplifier gain)

RE 3-18GHz PK+AV

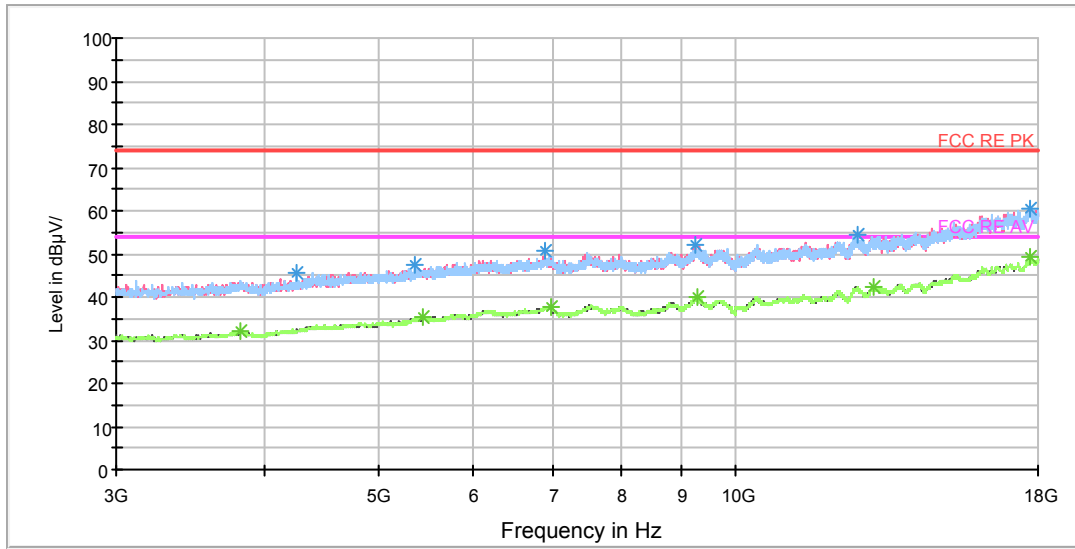

Radiates Emission from 3GHz to 18GHz

Frequency (MHz)	Peak (dBuV/m)	Height (cm)	Polarization	Azimuth (deg)	Reading value (dBuV/m)	Correct Factor (dB)	Margin (dB)	Limit (dBuV/m)
4256.250000	45.5	201.0	H	0.0	48.9	3.4	28.5	74.0
5355.000000	47.5	101.0	H	0.0	53.7	6.2	26.5	74.0
6903.750000	50.8	102.0	V	0.0	59.6	8.8	23.2	74.0
9247.500000	51.9	201.0	V	62.0	64.6	12.7	22.1	74.0
12671.250000	54.4	101.0	H	58.0	70.2	15.8	19.6	74.0
17722.500000	60.4	201.0	V	43.0	82.8	22.4	13.6	74.0

Remark: 1. Correction Factor = Antenna factor+ Insertion loss (cable loss + amplifier gain)

Frequency (MHz)	Average (dBuV/m)	Height (cm)	Polarization	Azimuth (deg)	Reading value (dBuV/m)	Correct Factor (dB)	Margin (dB)	Limit (dBuV/m)
3815.625000	32.1	201.0	V	25.0	34.3	2.2	21.9	54
5448.750000	35.4	201.0	V	0.0	41.8	6.4	18.6	54
6997.500000	37.8	102.0	V	153.0	46.9	9.1	16.2	54
9285.000000	40.0	201.0	H	111.0	52.7	12.7	14.0	54
13081.875000	42.2	201.0	V	210.0	58.8	16.6	11.8	54
17703.750000	49.2	101.0	H	77.0	71.6	22.4	4.8	54

Remark: 1. Correction Factor = Antenna factor+ Insertion loss (cable loss + amplifier gain)

RE 18-26.5GHz PK+AV

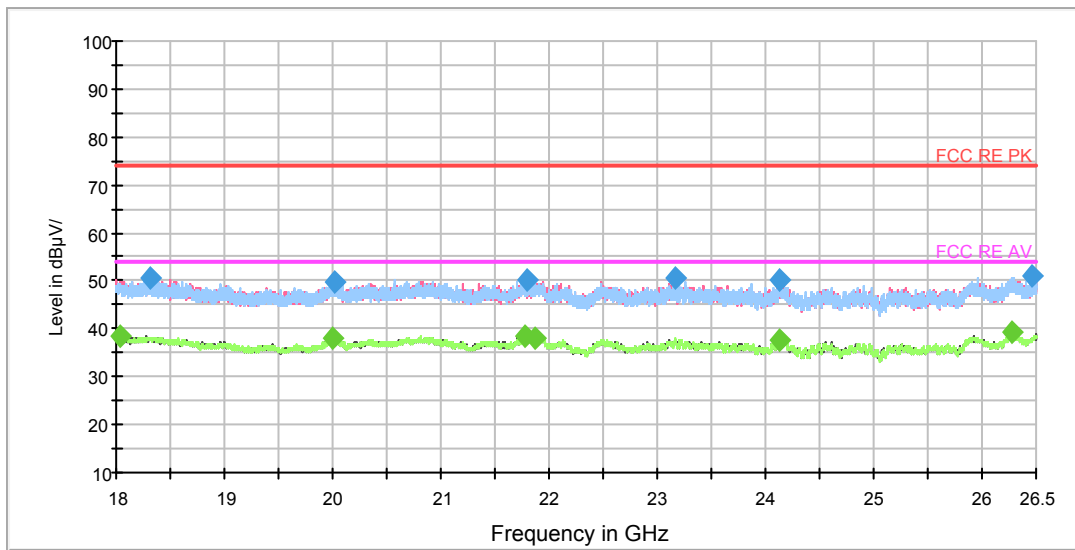

Radiates Emission from 18GHz to 26.5GHz

Frequency (MHz)	Peak (dBuV/m)	Polarization	Azimuth (deg)	Reading value (dBuV/m)	Correct Factor (dB)	Margin (dB)	Limit (dBuV/m)
18316.625000	50.7	V	137.0	53.8	-3.1	23.3	74.0
20017.156250	49.8	V	56.0	55.5	-5.7	24.2	74.0
21801.093750	50.3	H	0.0	58.3	-8.0	23.7	74.0
23166.406250	50.5	H	0.0	56.6	-6.1	23.5	74.0
24136.468750	50.0	V	180.0	55.9	-5.9	24.0	74.0
26459.625000	51.1	V	176.0	56.5	-5.4	22.9	74.0

Remark: 1. Correction Factor = Antenna factor+ Insertion loss (cable loss + amplifier gain)

Frequency (MHz)	Average (dBuV/m)	Polarization	Azimuth (deg)	Reading value (dBuV/m)	Correct Factor (dB)	Margin (dB)	Limit (dBuV/m)
18042.500000	38.6	V	70.0	40.6	-2.0	15.4	54.0
19998.562500	38.0	H	0.0	43.7	-5.7	16.0	54.0
21768.687500	38.3	V	163.0	46.3	-8.0	15.7	54.0
21878.656250	38.2	H	82.0	46.2	-8.0	15.8	54.0
24133.281250	37.8	V	163.0	43.7	-5.9	16.2	54.0
26277.406250	39.1	H	110.0	44.5	-5.4	14.9	54.0

Remark: 1. Correction Factor = Antenna factor+ Insertion loss (cable loss + amplifier gain)

802.11n (HT20) CH11

RE 0.03-1GHz QP Class B

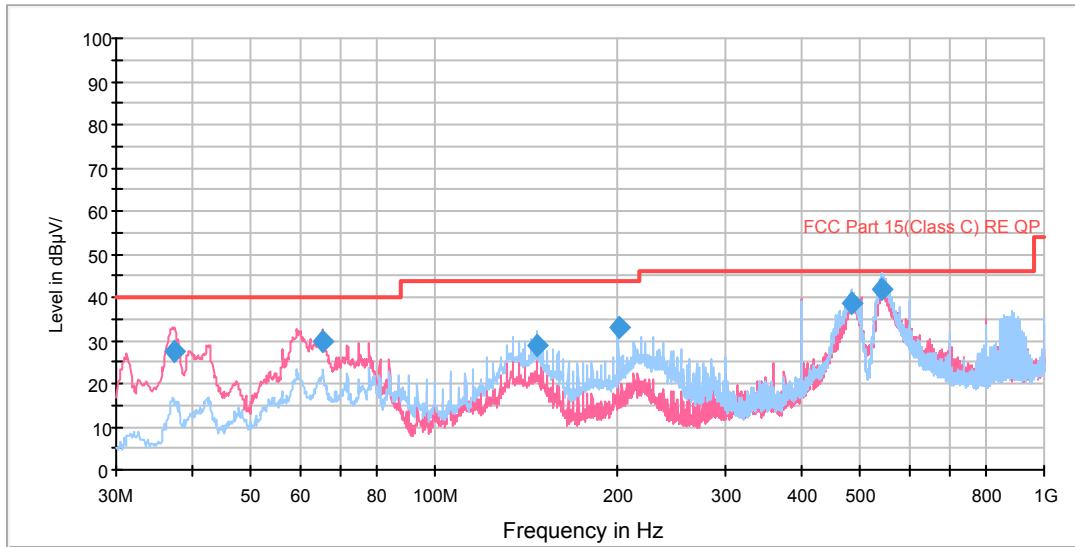

Radiates Emission from 30MHz to 1GHz

Frequency (MHz)	Quasi-Peak (dBuV/m)	Height (cm)	Polarization	Azimuth (deg)	Reading value (dBuV/m)	Correct Factor (dB)	Margin (dB)	Limit (dBuV/m)
37.336250	27.4	103.0	V	63.0	49.4	-22.0	12.6	40.0
65.627500	29.7	102.0	V	264.0	53.8	-24.1	10.3	40.0
146.865000	29.0	224.0	H	315.0	58.6	-29.6	14.5	43.5
200.012500	33.0	177.0	H	248.0	59.3	-26.3	10.5	43.5
481.555000	38.8	100.0	H	0.0	58.2	-19.4	7.2	46.0
541.130000	42.1	102.0	H	7.0	60.4	-18.3	3.9	46.0

- Remark: 1. Quasi-Peak = Reading value + Correction factor
 2. Correction Factor = Antenna factor+ Insertion loss(cable loss+amplifier gain)
 3. Margin = Limit – Quasi-Peak

RE 1G-3GHz PK+AV

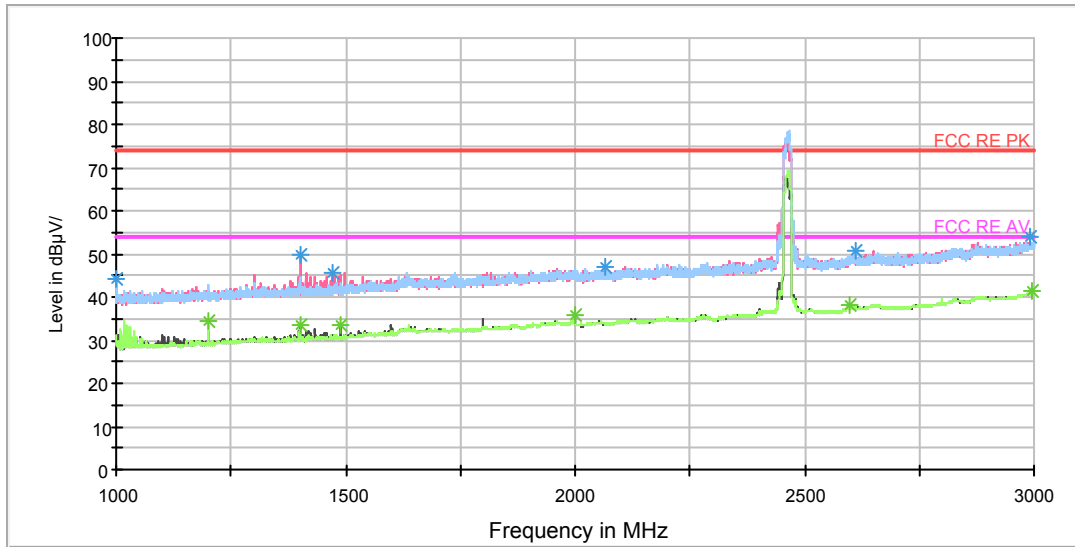

Note: The signal beyond the limit is carrier.

Radiates Emission from 1GHz to 3GHz

Frequency (MHz)	Peak (dBuV/m)	Height (cm)	Polarization	Azimuth (deg)	Reading value (dBuV/m)	Correct Factor (dB)	Margin (dB)	Limit (dBuV/m)
1000.250000	44.1	202.0	V	0.0	53.3	-9.2	29.9	74
1400.000000	49.9	202.0	V	0.0	57.0	-7.1	24.1	74
1469.500000	45.8	103.0	V	121.0	52.5	-6.7	28.2	74
2063.750000	46.9	102.0	H	320.0	50.0	-3.1	27.1	74
2609.250000	50.8	202.0	H	179.0	51.0	0.2	23.2	74
2990.250000	53.8	202.0	V	44.0	56.0	2.2	20.2	74

Remark: 1. Correction Factor = Antenna factor+ Insertion loss (cable loss + amplifier gain)

Frequency (MHz)	Average (dBuV/m)	Height (cm)	Polarization	Azimuth (deg)	Reading value (dBuV/m)	Correct Factor (dB)	Margin (dB)	Limit (dBuV/m)
1199.750000	34.6	202.0	H	256.0	42.8	-8.2	19.4	54
1400.000000	33.3	202.0	V	0.0	40.4	-7.1	20.7	54
1487.750000	33.5	103.0	V	277.0	40.2	-6.7	20.5	54
2000.000000	35.7	202.0	V	342.0	39.1	-3.4	18.3	54
2600.000000	38.1	202.0	V	6.0	38.5	0.4	15.9	54
2996.500000	41.3	202.0	H	0.0	43.6	2.3	12.7	54

Remark: 1. Correction Factor = Antenna factor+ Insertion loss (cable loss + amplifier gain)

RE 3-18GHz PK+AV

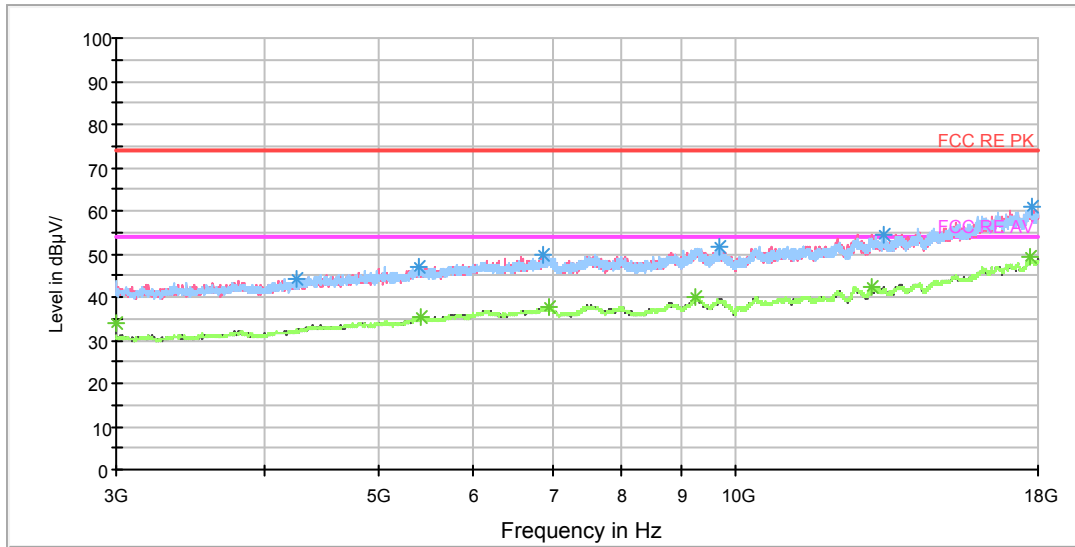

Radiates Emission from 3GHz to 18GHz

Frequency (MHz)	Peak (dBuV/m)	Height (cm)	Polarization	Azimuth (deg)	Reading value (dBuV/m)	Correct Factor (dB)	Margin (dB)	Limit (dBuV/m)
4263.750000	44.2	201.0	H	355.0	47.6	3.4	29.8	74
5403.750000	47.2	201.0	V	117.0	53.5	6.3	26.8	74
6888.750000	49.6	201.0	H	336.0	58.4	8.8	24.4	74
9705.000000	51.8	201.0	H	0.0	64.2	12.4	22.2	74
13331.250000	54.5	201.0	H	336.0	71.0	16.5	19.5	74
17760.000000	61.1	101.0	V	151.0	83.5	22.4	12.9	74

Remark: 1. Correction Factor = Antenna factor+ Insertion loss (cable loss + amplifier gain)

Frequency (MHz)	Average (dBuV/m)	Height (cm)	Polarization	Azimuth (deg)	Reading value (dBuV/m)	Correct Factor (dB)	Margin (dB)	Limit (dBuV/m)
3000.000000	34.1	101.0	V	0.0	34.5	0.4	19.9	54
5415.000000	35.3	201.0	V	208.0	41.7	6.4	18.7	54
6967.500000	37.7	101.0	V	280.0	46.7	9.0	16.3	54
9247.500000	40.0	100.0	H	229.0	52.7	12.7	14.0	54
13031.250000	42.2	101.0	V	260.0	58.8	16.6	11.8	54
17737.500000	49.1	101.0	V	334.0	71.5	22.4	4.9	54

Remark: 1. Correction Factor = Antenna factor+ Insertion loss (cable loss + amplifier gain)

RE 18-26.5GHz PK+AV

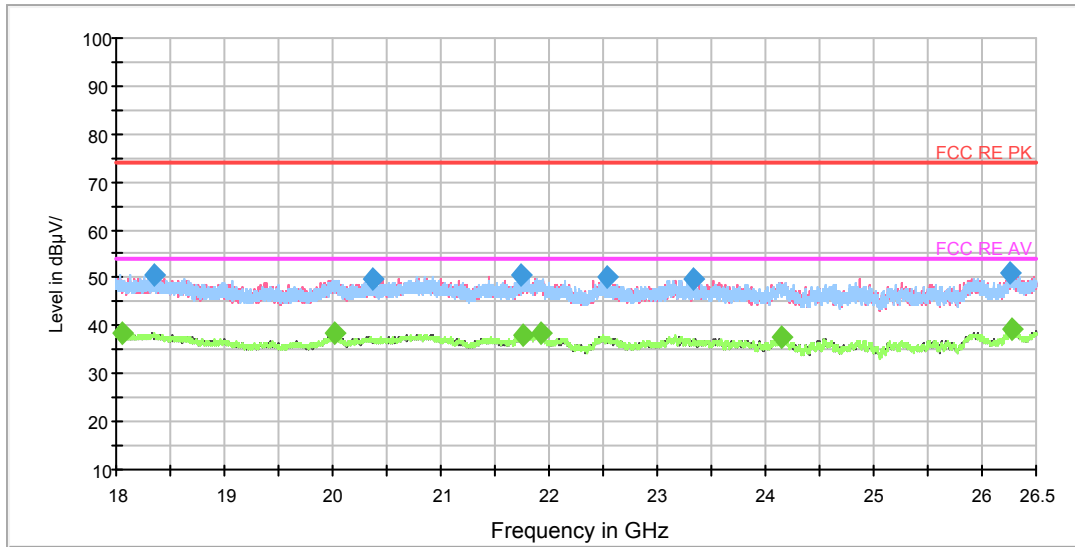

Radiates Emission from 18GHz to 26.5GHz

Frequency (MHz)	Peak (dBuV/m)	Polarization	Azimuth (deg)	Reading value (dBuV/m)	Correct Factor (dB)	Margin (dB)	Limit (dBuV/m)
18344.250000	50.5	V	180.0	53.8	-3.3	23.5	74.0
20373.093750	49.8	H	0.0	55.9	-6.1	24.2	74.0
21748.500000	50.5	H	82.0	58.5	-8.0	23.5	74.0
22530.500000	50.2	V	152.0	57.0	-6.8	23.8	74.0
23341.718750	49.7	H	0.0	55.6	-5.9	24.3	74.0
26251.906250	51.2	V	180.0	56.6	-5.4	22.8	74.0

Remark: 1. Correction Factor = Antenna factor+ Insertion loss (cable loss + amplifier gain)

Frequency (MHz)	Average (dBuV/m)	Polarization	Azimuth (deg)	Reading value (dBuV/m)	Correct Factor (dB)	Margin (dB)	Limit (dBuV/m)
18049.937500	38.6	V	165.0	40.6	-2.0	15.4	54.0
20023.000000	38.3	H	180.0	44.0	-5.7	15.7	54.0
21759.125000	38.2	V	85.0	46.2	-8.0	15.8	54.0
21920.625000	38.4	H	0.0	46.4	-8.0	15.6	54.0
24148.156250	37.6	H	169.0	43.5	-5.9	16.4	54.0
26274.218750	39.2	V	0.0	44.6	-5.4	14.8	54.0

Remark: 1. Correction Factor = Antenna factor+ Insertion loss (cable loss + amplifier gain)



802.11n (HT40) CH3

RE 0.03-1GHz QP Class B

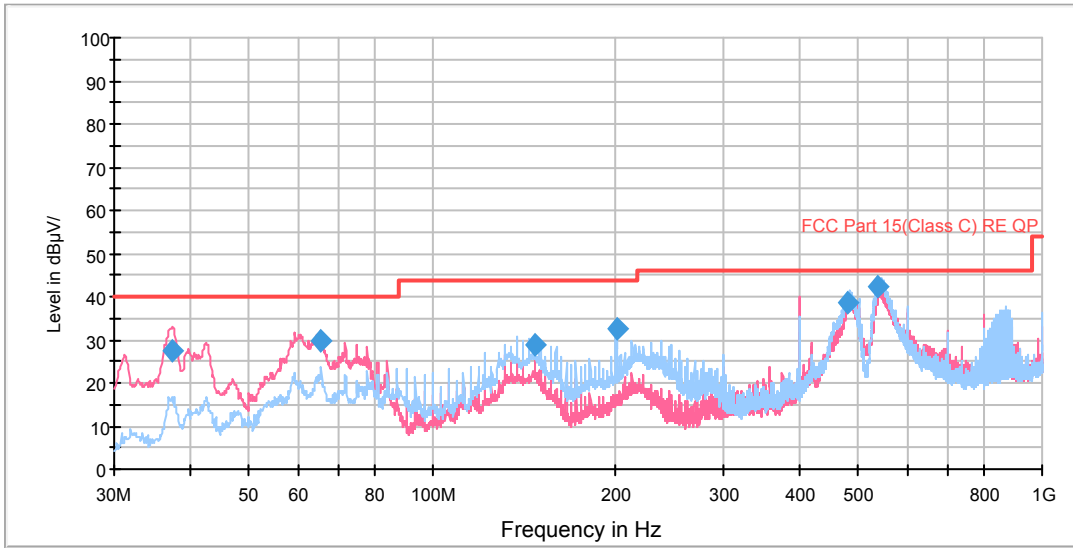

Radiates Emission from 30MHz to 1GHz

Frequency (MHz)	Quasi-Peak (dBuV/m)	Height (cm)	Polarization	Azimuth (deg)	Reading value (dBuV/m)	Correct Factor (dB)	Margin (dB)	Limit (dBuV/m)
37.336250	27.3	101.0	V	7.0	49.3	-22.0	12.7	40.0
65.627500	29.9	100.0	V	231.0	54.0	-24.1	10.1	40.0
146.865000	29.0	227.0	H	302.0	58.6	-29.6	14.5	43.5
200.012500	32.5	199.0	H	250.0	58.8	-26.3	11.0	43.5
481.231250	38.8	102.0	H	0.0	58.2	-19.4	7.2	46.0
538.946250	42.1	100.0	H	0.0	60.4	-18.3	3.9	46.0

- Remark: 1. Quasi-Peak = Reading value + Correction factor
 2. Correction Factor = Antenna factor+ Insertion loss(cable loss+amplifier gain)
 3. Margin = Limit – Quasi-Peak

RE 1G-3GHz PK+AV

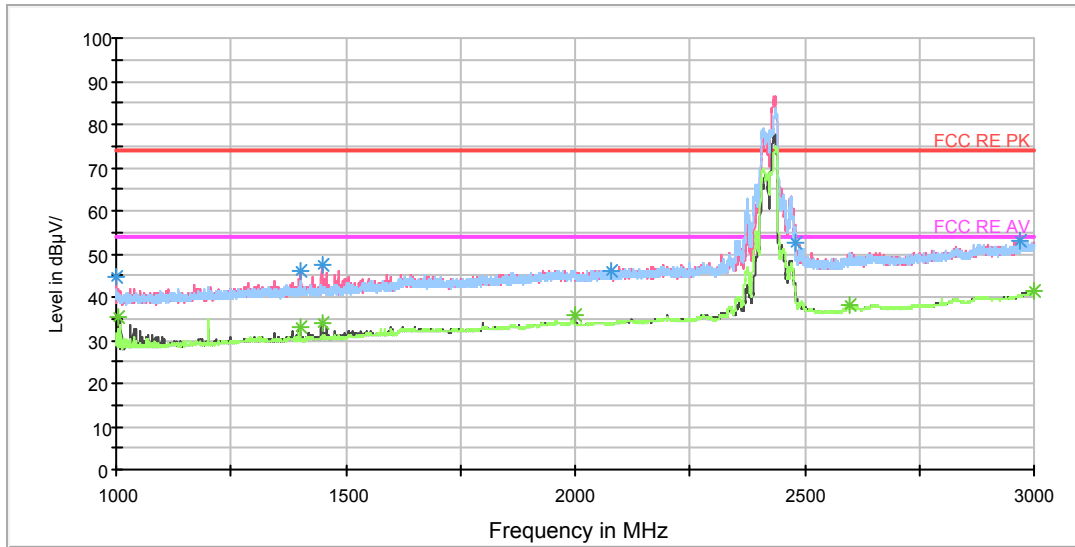

Note: The signal beyond the limit is carrier.
Radiates Emission from 1GHz to 3GHz

Frequency (MHz)	Peak (dBuV/m)	Height (cm)	Polarization	Azimuth (deg)	Reading value (dBuV/m)	Correct Factor (dB)	Margin (dB)	Limit (dBuV/m)
1000.250000	44.6	202.0	V	25.0	53.8	-9.2	29.4	74
1403.250000	46.0	102.0	V	244.0	53.1	-7.1	28.0	74
1447.750000	47.5	102.0	V	244.0	54.2	-6.7	26.5	74
2077.500000	46.2	202.0	V	0.0	49.2	-3.0	27.8	74
2480.500000	52.4	202.0	V	140.0	52.9	-0.5	21.6	74
2970.750000	53.0	102.0	V	322.0	55.2	2.2	21.0	74

Remark: 1. Correction Factor = Antenna factor+ Insertion loss (cable loss + amplifier gain)

Frequency (MHz)	Average (dBuV/m)	Height (cm)	Polarization	Azimuth (deg)	Reading value (dBuV/m)	Correct Factor (dB)	Margin (dB)	Limit (dBuV/m)
1003.500000	35.4	202.0	V	218.0	44.7	-9.3	18.6	54
1400.250000	33.2	202.0	V	0.0	40.3	-7.1	20.8	54
1447.750000	34.1	102.0	V	244.0	40.8	-6.7	19.9	54
2000.000000	35.7	102.0	V	0.0	39.1	-3.4	18.3	54
2599.750000	38.1	202.0	V	25.0	38.5	0.4	15.9	54
3000.000000	41.3	102.0	V	122.0	43.6	2.3	12.7	54

Remark: 1. Correction Factor = Antenna factor+ Insertion loss (cable loss + amplifier gain)

RE 3-18GHz PK+AV

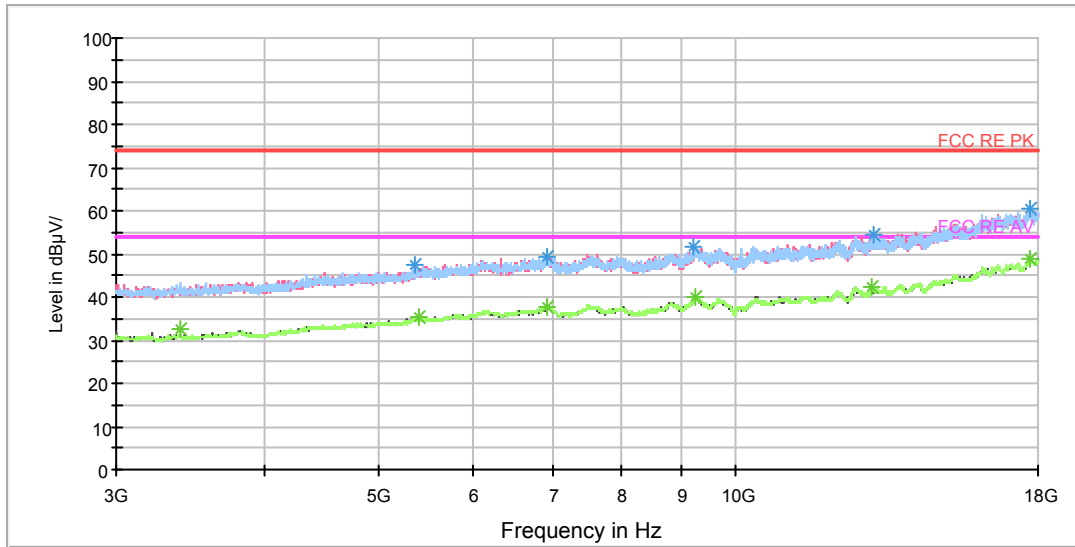

Radiates Emission from 3GHz to 18GHz

Frequency (MHz)	Peak (dBuV/m)	Height (cm)	Polarization	Azimuth (deg)	Reading value (dBuV/m)	Correct Factor (dB)	Margin (dB)	Limit (dBuV/m)
5360.625000	47.3	201.0	V	43.0	53.5	6.2	26.7	74
6939.375000	49.5	201.0	H	153.0	58.4	8.9	24.5	74
9219.375000	51.6	201.0	V	25.0	64.3	12.7	22.4	74
13091.250000	54.3	100.0	V	0.0	70.9	16.6	19.7	74
17688.750000	60.4	100.0	V	230.0	82.8	22.4	13.6	74
5360.625000	47.3	201.0	V	43.0	53.5	6.2	26.7	74

Remark: 1. Correction Factor = Antenna factor+ Insertion loss (cable loss + amplifier gain)

Frequency (MHz)	Average (dBuV/m)	Height (cm)	Polarization	Azimuth (deg)	Reading value (dBuV/m)	Correct Factor (dB)	Margin (dB)	Limit (dBuV/m)
3399.375000	32.5	100.0	H	306.0	33.5	1.0	21.5	54
5401.875000	35.2	100.0	H	0.0	41.5	6.3	18.8	54
6930.000000	37.7	201.0	H	0.0	46.6	8.9	16.3	54
9245.625000	40.0	201.0	V	0.0	52.7	12.7	14.0	54
13025.625000	42.2	201.0	V	79.0	58.8	16.6	11.8	54
17741.250000	49.0	100.0	V	59.0	71.4	22.4	5.0	54

Remark: 1. Correction Factor = Antenna factor+ Insertion loss (cable loss + amplifier gain)

RE 18-26.5GHz PK+AV

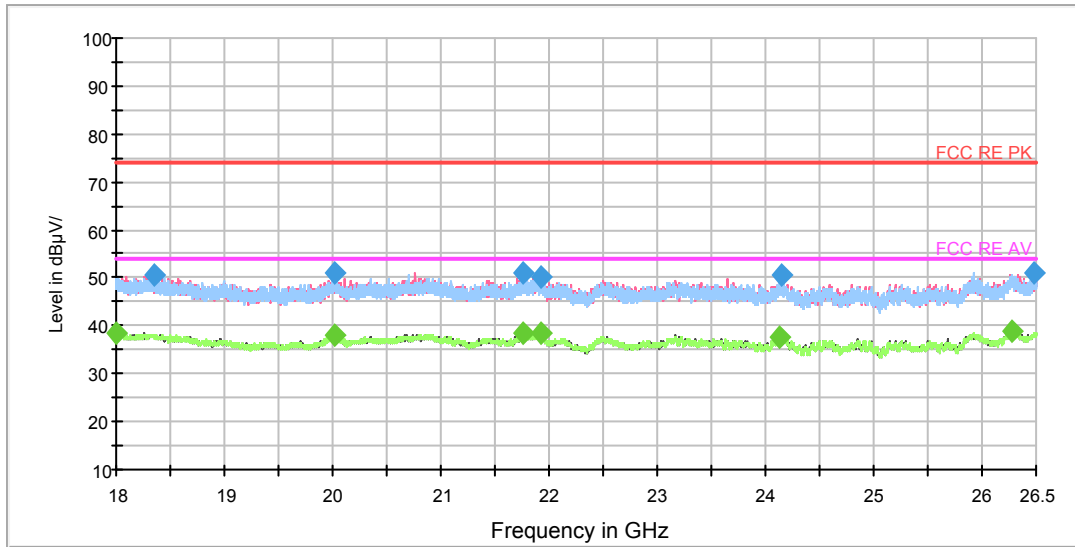

Radiates Emission from 18GHz to 26.5GHz

Frequency (MHz)	Peak (dBuV/m)	Polarization	Azimuth (deg)	Reading value (dBuV/m)	Correct Factor (dB)	Margin (dB)	Limit (dBuV/m)
18349.031250	50.8	V	180.0	54.1	-3.3	23.2	74.0
20012.906250	50.9	V	83.0	56.6	-5.7	23.1	74.0
21755.937500	51.0	V	163.0	59.0	-8.0	23.0	74.0
21916.906250	50.3	H	0.0	58.3	-8.0	23.7	74.0
24142.843750	50.7	H	169.0	56.6	-5.9	23.3	74.0
26479.812500	51.1	V	41.0	56.5	-5.4	22.9	74.0

Remark: 1. Correction Factor = Antenna factor+ Insertion loss (cable loss + amplifier gain)

Frequency (MHz)	Average (dBuV/m)	Polarization	Azimuth (deg)	Reading value (dBuV/m)	Correct Factor (dB)	Margin (dB)	Limit (dBuV/m)
18002.125000	38.4	V	163.0	40.2	-1.8	15.6	54.0
20023.531250	38.1	V	96.0	43.8	-5.7	15.9	54.0
21766.031250	38.4	V	180.0	46.4	-8.0	15.6	54.0
21919.031250	38.3	V	56.0	46.3	-8.0	15.7	54.0
24131.156250	37.8	H	80.0	43.7	-5.9	16.2	54.0
26274.218750	39.1	H	153.0	44.5	-5.4	14.9	54.0

Remark: 1. Correction Factor = Antenna factor+ Insertion loss (cable loss + amplifier gain)



802.11n (HT40) CH6

RE 0.03-1GHz QP Class B

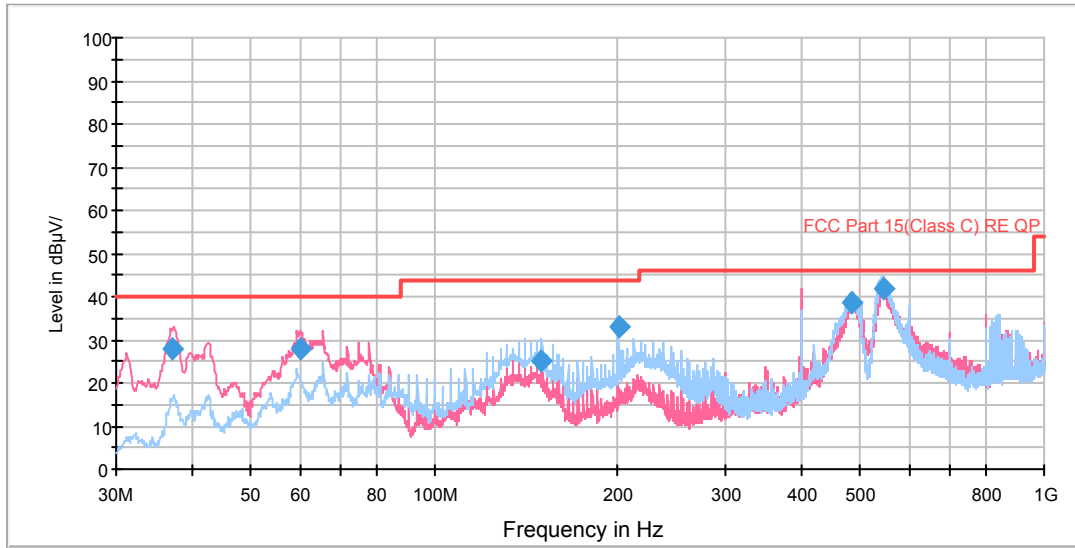

Radiates Emission from 30MHz to 1GHz

Frequency (MHz)	Quasi-Peak (dBuV/m)	Height (cm)	Polarization	Azimuth (deg)	Reading value (dBuV/m)	Correct Factor (dB)	Margin (dB)	Limit (dBuV/m)
37.215000	27.8	102.0	V	22.0	49.9	-22.1	12.2	40.0
60.131250	27.8	100.0	V	258.0	51.0	-23.2	12.2	40.0
149.976250	25.2	227.0	H	332.0	54.4	-29.2	18.3	43.5
200.012500	32.8	177.0	H	249.0	59.1	-26.3	10.7	43.5
481.676250	38.7	100.0	H	0.0	58.1	-19.4	7.3	46.0
547.070000	41.8	102.0	H	6.0	60.1	-18.3	4.2	46.0

- Remark: 1. Quasi-Peak = Reading value + Correction factor
 2. Correction Factor = Antenna factor+ Insertion loss(cable loss+amplifier gain)
 3. Margin = Limit – Quasi-Peak

RE 1G-3GHz PK+AV

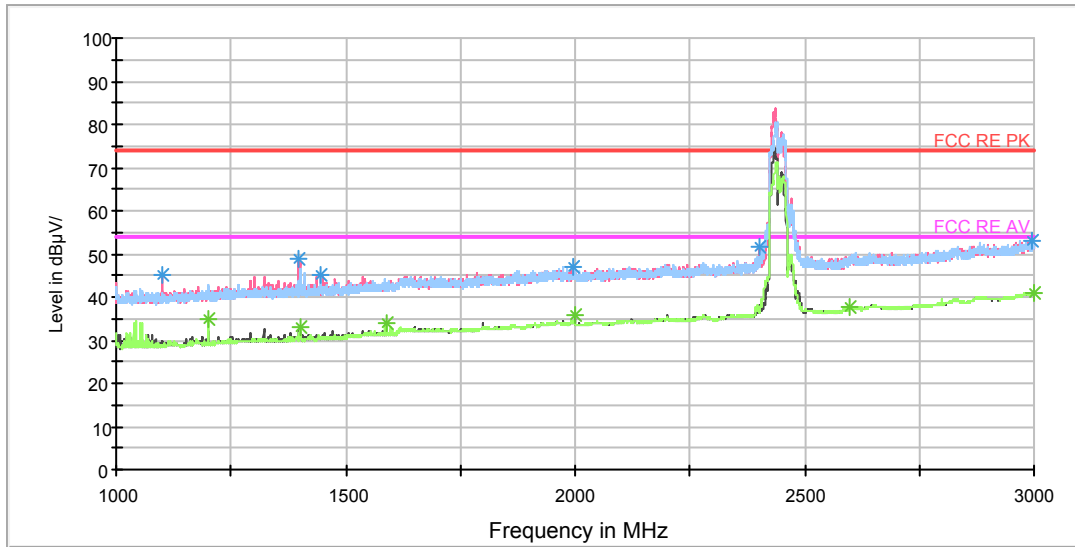

Note: The signal beyond the limit is carrier.
Radiates Emission from 1GHz to 3GHz

Frequency (MHz)	Peak (dBuV/m)	Height (cm)	Polarization	Azimuth (deg)	Reading value (dBuV/m)	Correct Factor (dB)	Margin (dB)	Limit (dBuV/m)
1099.500000	44.9	202.0	V	0.0	53.8	-8.9	29.1	74
1399.250000	48.7	102.0	V	338.0	55.8	-7.1	25.3	74
1446.250000	45.2	102.0	H	161.0	51.9	-6.7	28.8	74
1995.500000	46.9	102.0	V	141.0	50.1	-3.2	27.1	74
2400.250000	51.5	202.0	V	0.0	52.7	-1.2	22.5	74
2994.250000	53.0	102.0	V	317.0	55.3	2.3	21.0	74

Remark: 1. Correction Factor = Antenna factor+ Insertion loss (cable loss + amplifier gain)

Frequency (MHz)	Average (dBuV/m)	Height (cm)	Polarization	Azimuth (deg)	Reading value (dBuV/m)	Correct Factor (dB)	Margin (dB)	Limit (dBuV/m)
1200.000000	35.1	202.0	H	355.0	43.3	-8.2	18.9	54
1400.000000	33.2	202.0	V	342.0	40.3	-7.1	20.8	54
1590.750000	33.7	202.0	H	238.0	40.1	-6.4	20.3	54
2000.000000	35.7	202.0	V	0.0	39.1	-3.4	18.3	54
2599.750000	37.9	202.0	V	101.0	38.3	0.4	16.1	54
2998.250000	41.0	102.0	V	297.0	43.3	2.3	13.0	54

Remark: 1. Correction Factor = Antenna factor+ Insertion loss (cable loss + amplifier gain)

RE 3-18GHz PK+AV

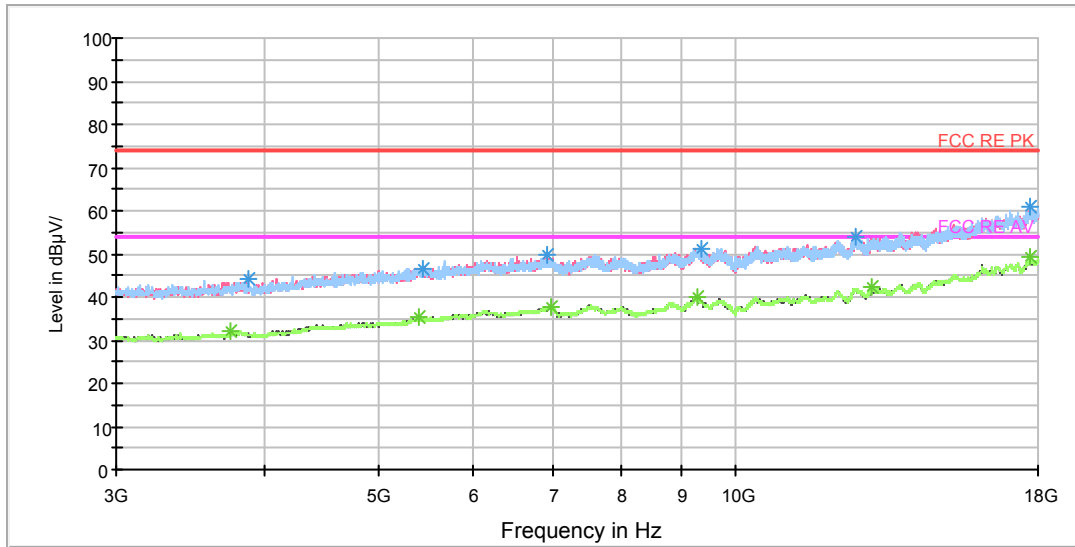

Radiates Emission from 3GHz to 18GHz

Frequency (MHz)	Peak (dBuV/m)	Height (cm)	Polarization	Azimuth (deg)	Reading value (dBuV/m)	Correct Factor (dB)	Margin (dB)	Limit (dBuV/m)
3879.375000	44.3	100.0	H	193.0	46.4	2.1	29.7	74
5443.125000	46.6	201.0	H	0.0	53.0	6.4	27.4	74
6933.750000	49.8	201.0	V	5.0	58.7	8.9	24.2	74
9360.000000	51.4	100.0	V	0.0	64.1	12.7	22.6	74
12603.750000	53.8	100.0	V	0.0	69.4	15.6	20.2	74
17718.750000	60.7	100.0	V	0.0	83.1	22.4	13.3	74

Remark: 1. Correction Factor = Antenna factor+ Insertion loss (cable loss + amplifier gain)

Frequency (MHz)	Average (dBuV/m)	Height (cm)	Polarization	Azimuth (deg)	Reading value (dBuV/m)	Correct Factor (dB)	Margin (dB)	Limit (dBuV/m)
3750.000000	32.1	100.0	V	335.0	34.0	1.9	21.9	54
5407.500000	35.3	201.0	V	24.0	41.6	6.3	18.7	54
6991.875000	37.8	100.0	H	0.0	46.9	9.1	16.2	54
9294.375000	40.0	100.0	V	75.0	52.7	12.7	14.0	54
13018.125000	42.3	201.0	H	228.0	58.9	16.6	11.7	54
17703.750000	49.2	201.0	H	134.0	71.6	22.4	4.8	54

Remark: 1. Correction Factor = Antenna factor+ Insertion loss (cable loss + amplifier gain)

RE 18-26.5GHz PK+AV

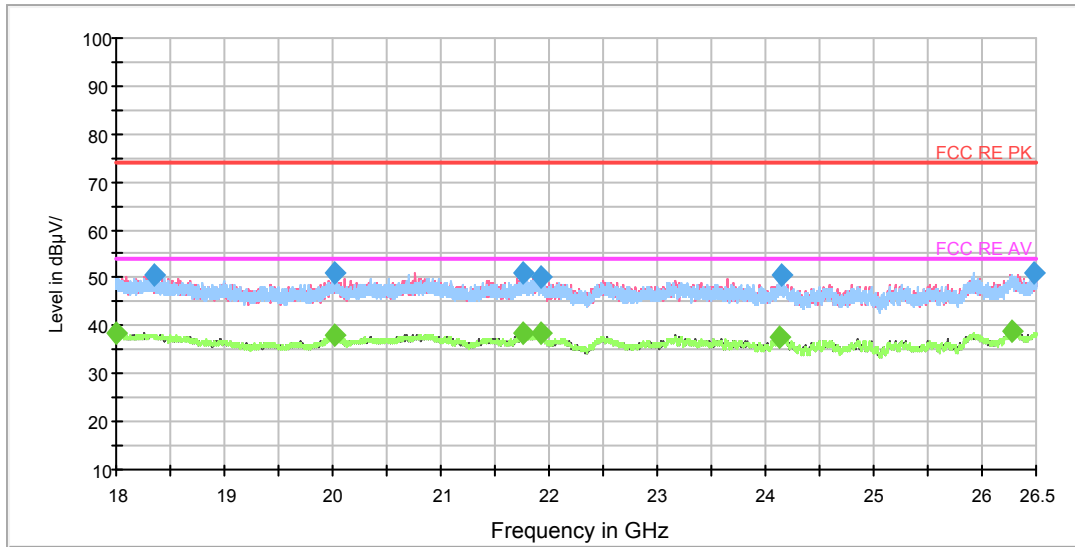

Radiates Emission from 18GHz to 26.5GHz

Frequency (MHz)	Peak (dBuV/m)	Polarization	Azimuth (deg)	Reading value (dBuV/m)	Correct Factor (dB)	Margin (dB)	Limit (dBuV/m)
18349.031250	50.8	V	180.0	54.1	-3.3	23.2	74.0
20012.906250	50.9	V	83.0	56.6	-5.7	23.1	74.0
21755.937500	51.0	V	163.0	59.0	-8.0	23.0	74.0
21916.906250	50.3	H	0.0	58.3	-8.0	23.7	74.0
24142.843750	50.7	H	169.0	56.6	-5.9	23.3	74.0
26479.812500	51.1	V	41.0	56.5	-5.4	22.9	74.0

Remark: 1. Correction Factor = Antenna factor+ Insertion loss (cable loss + amplifier gain)

Frequency (MHz)	Average (dBuV/m)	Polarization	Azimuth (deg)	Reading value (dBuV/m)	Correct Factor (dB)	Margin (dB)	Limit (dBuV/m)
18002.125000	38.4	V	163.0	40.2	-1.8	15.6	54.0
20023.531250	38.1	V	96.0	43.8	-5.7	15.9	54.0
21766.031250	38.4	V	180.0	46.4	-8.0	15.6	54.0
21919.031250	38.3	V	56.0	46.3	-8.0	15.7	54.0
24131.156250	37.8	H	80.0	43.7	-5.9	16.2	54.0
26274.218750	39.1	H	153.0	44.5	-5.4	14.9	54.0

Remark: 1. Correction Factor = Antenna factor+ Insertion loss (cable loss + amplifier gain)

802.11n (HT40) CH9

RE 0.03-1GHz QP Class B

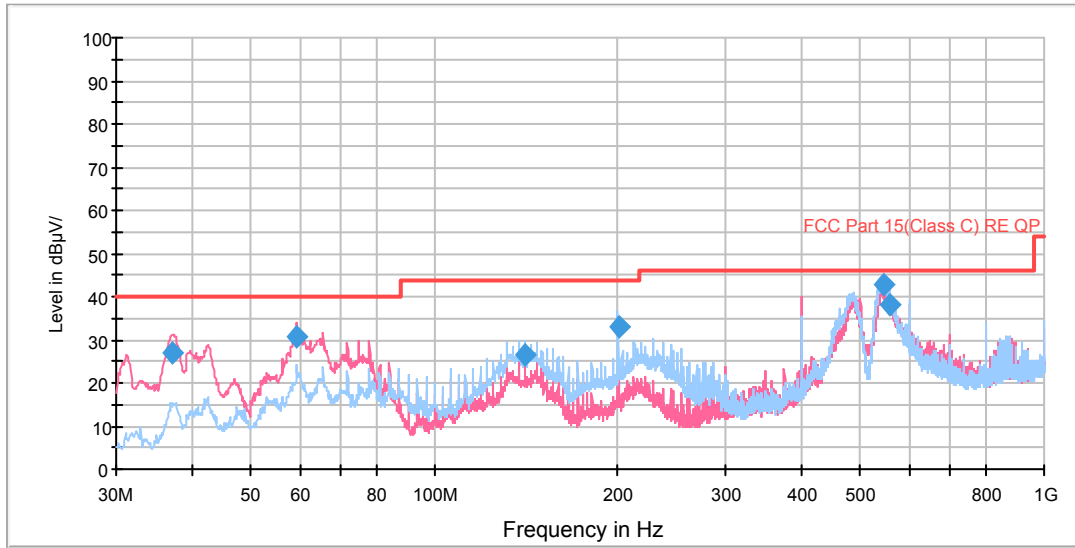

Radiates Emission from 30MHz to 1GHz

Frequency (MHz)	Quasi-Peak (dBuV/m)	Height (cm)	Polarization	Azimuth (deg)	Reading value (dBuV/m)	Correct Factor (dB)	Margin (dB)	Limit (dBuV/m)
37.052500	27.1	100.0	V	240.0	49.2	-22.1	12.9	40.0
59.362500	30.6	102.0	V	240.0	53.6	-23.0	9.4	40.0
140.640000	26.5	197.0	H	120.0	56.1	-29.6	17.0	43.5
200.012500	33.1	127.0	H	6.0	59.4	-26.3	10.4	43.5
545.211250	42.7	100.0	H	0.0	61.0	-18.3	3.3	46.0
558.630000	38.2	102.0	H	0.0	56.6	-18.4	7.8	46.0

- Remark:**
1. Quasi-Peak = Reading value + Correction factor
 2. Correction Factor = Antenna factor+ Insertion loss(cable loss+amplifier gain)
 3. Margin = Limit – Quasi-Peak

RE 1G-3GHz PK+AV

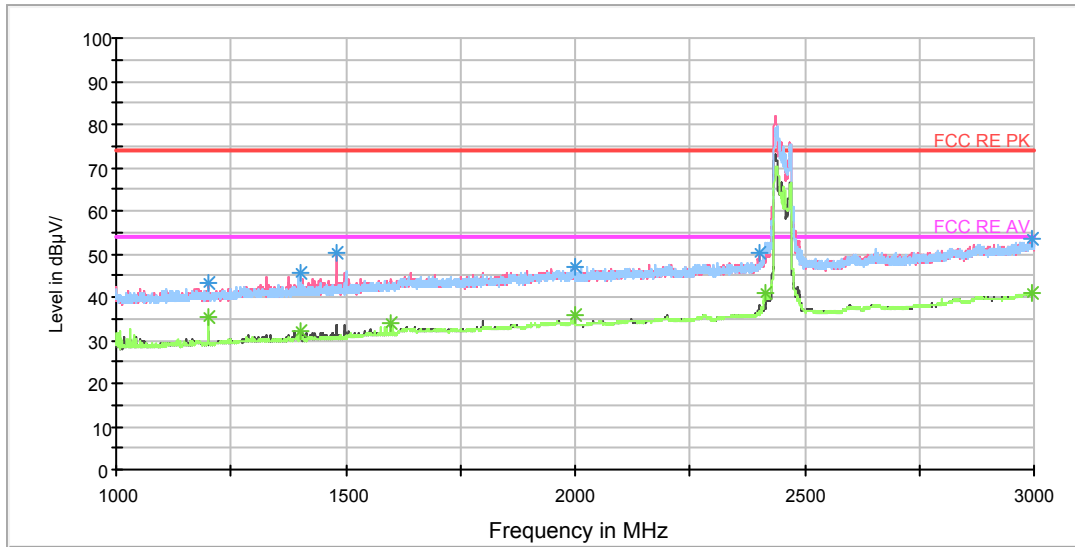

Note: The signal beyond the limit is carrier.

Radiates Emission from 1GHz to 3GHz

Frequency (MHz)	Peak (dBuV/m)	Height (cm)	Polarization	Azimuth (deg)	Reading value (dBuV/m)	Correct Factor (dB)	Margin (dB)	Limit (dBuV/m)
1200.750000	43.3	202.0	V	4.0	51.5	-8.2	30.7	74
1400.250000	45.5	202.0	H	237.0	52.6	-7.1	28.5	74
1481.500000	50.4	102.0	V	256.0	56.9	-6.5	23.6	74
1999.750000	46.9	202.0	V	0.0	50.3	-3.4	27.1	74
2400.000000	50.1	202.0	V	0.0	51.3	-1.2	23.9	74
2994.250000	53.3	202.0	V	240.0	55.6	2.3	20.7	74

Remark: 1. Correction Factor = Antenna factor+ Insertion loss (cable loss + amplifier gain)

Frequency (MHz)	Average (dBuV/m)	Height (cm)	Polarization	Azimuth (deg)	Reading value (dBuV/m)	Correct Factor (dB)	Margin (dB)	Limit (dBuV/m)
1200.000000	35.4	202.0	H	257.0	43.6	-8.2	18.6	54
1400.250000	32.3	202.0	H	237.0	39.4	-7.1	21.7	54
1599.750000	33.8	202.0	V	0.0	40.2	-6.4	20.2	54
2000.000000	35.8	202.0	V	0.0	39.2	-3.4	18.2	54
2417.000000	40.7	202.0	H	218.0	41.3	-0.6	13.3	54
2996.500000	41.1	202.0	V	0.0	43.4	2.3	12.9	54

Remark: 1. Correction Factor = Antenna factor+ Insertion loss (cable loss + amplifier gain)

RE 3-18GHz PK+AV

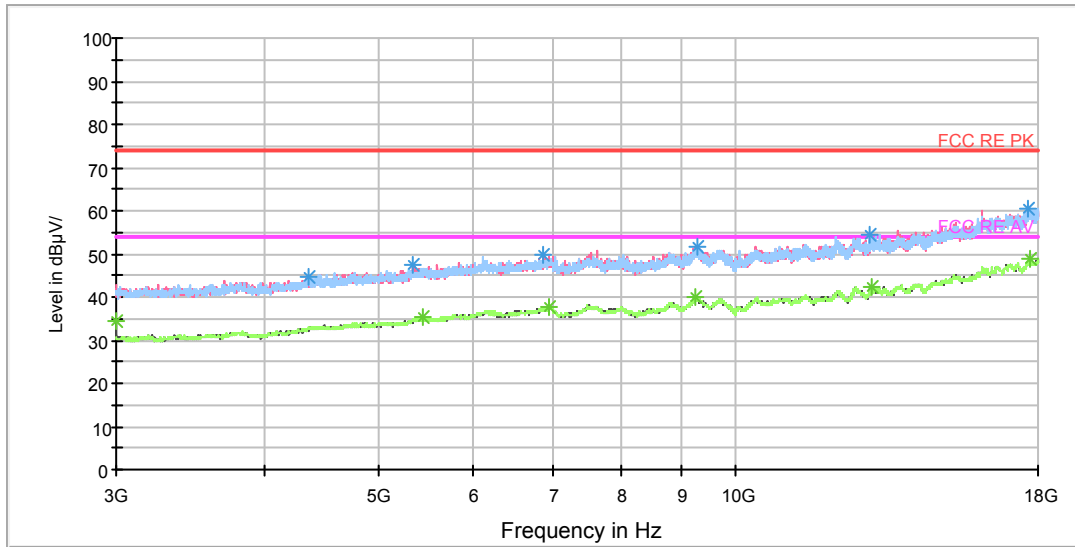

Radiates Emission from 3GHz to 18GHz

Frequency (MHz)	Peak (dBuV/m)	Height (cm)	Polarization	Azimuth (deg)	Reading value (dBuV/m)	Correct Factor (dB)	Margin (dB)	Limit (dBuV/m)
4366.875000	44.5	201.0	H	350.0	48.2	3.7	29.5	74
5332.500000	47.3	201.0	V	0.0	53.4	6.1	26.7	74
6883.125000	49.7	201.0	V	83.0	58.5	8.8	24.3	74
9286.875000	51.6	100.0	V	54.0	64.3	12.7	22.4	74
12969.375000	54.6	201.0	H	0.0	71.2	16.6	19.4	74
17679.375000	60.5	102.0	H	190.0	82.9	22.4	13.5	74

Remark: 1. Correction Factor = Antenna factor+ Insertion loss (cable loss + amplifier gain)

Frequency (MHz)	Average (dBuV/m)	Height (cm)	Polarization	Azimuth (deg)	Reading value (dBuV/m)	Correct Factor (dB)	Margin (dB)	Limit (dBuV/m)
3000.000000	34.3	100.0	V	0.0	34.7	0.4	19.7	54
5435.625000	35.3	201.0	V	211.0	41.7	6.4	18.7	54
6950.625000	37.7	201.0	H	312.0	46.7	9.0	16.3	54
9255.000000	40.0	100.0	V	316.0	52.7	12.7	14.0	54
13035.000000	42.2	100.0	V	279.0	58.8	16.6	11.8	54
17713.125000	49.0	201.0	V	64.0	71.4	22.4	5.0	54

Remark: 1. Correction Factor = Antenna factor+ Insertion loss (cable loss + amplifier gain)

RE 18-26.5GHz PK+AV

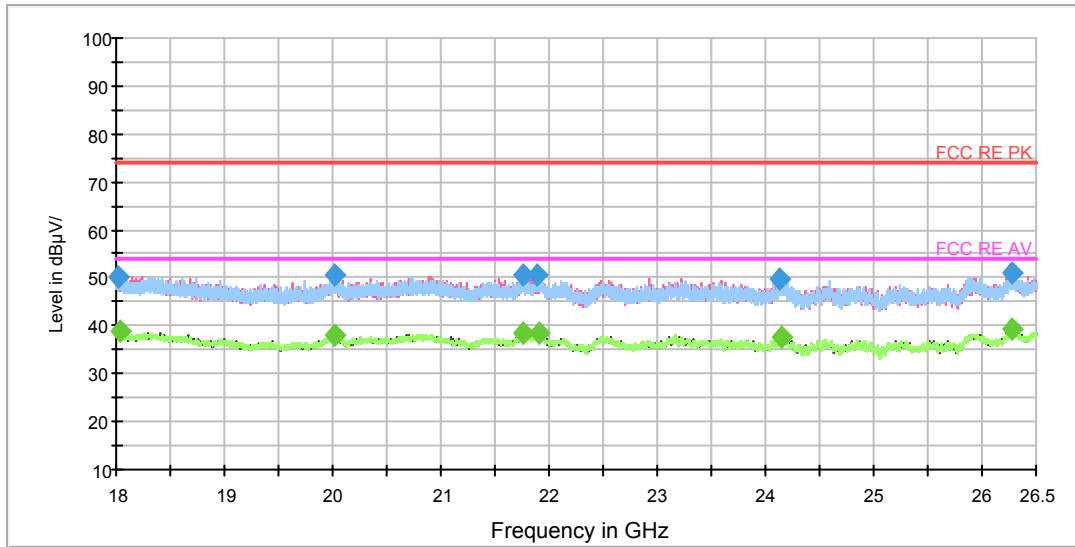

Radiates Emission from 18GHz to 26.5GHz

Frequency (MHz)	Peak (dBuV/m)	Polarization	Azimuth (deg)	Reading value (dBuV/m)	Correct Factor (dB)	Margin (dB)	Limit (dBuV/m)
18021.781250	50.4	H	122.0	52.3	-1.9	23.6	74.0
20009.718750	50.4	H	1.0	56.1	-5.7	23.6	74.0
21754.343750	50.5	V	153.0	58.5	-8.0	23.5	74.0
21879.718750	50.5	H	54.0	58.5	-8.0	23.5	74.0
24123.718750	50.0	H	80.0	55.9	-5.9	24.0	74.0
26276.875000	51.0	H	14.0	56.4	-5.4	23.0	74.0

Remark: 1. Correction Factor = Antenna factor+ Insertion loss (cable loss + amplifier gain)

Frequency (MHz)	Average (dBuV/m)	Polarization	Azimuth (deg)	Reading value (dBuV/m)	Correct Factor (dB)	Margin (dB)	Limit (dBuV/m)
18041.437500	38.7	V	180.0	40.7	-2.0	15.3	54.0
20020.875000	38.1	V	86.0	43.8	-5.7	15.9	54.0
21758.593750	38.3	H	0.0	46.3	-8.0	15.7	54.0
21902.562500	38.4	H	0.0	46.4	-8.0	15.6	54.0
24146.031250	37.7	H	41.0	43.6	-5.9	16.3	54.0
26283.781250	39.3	H	0.0	44.7	-5.4	14.7	54.0

Remark: 1. Correction Factor = Antenna factor+ Insertion loss (cable loss + amplifier gain)

5.8. Conducted Emission

Ambient condition

Temperature	Relative humidity	Pressure
23°C ~25°C	45%~50%	101.5kPa

Methods of Measurement

The EUT is placed on a non-metallic table of 80cm height above the horizontal metal reference ground plane. During the test, the EUT was operating in its typical mode. The test method is according to ANSI C63.10-2013. Connect the AC power line of the EUT to the L.I.S.N. Use EMI receiver to detect the average and Quasi-peak value. RBW is set to 9 kHz, VBW is set to 30kHz. The measurement result should include both L line and N line.

The test is in transmitting mode.

Test Setup

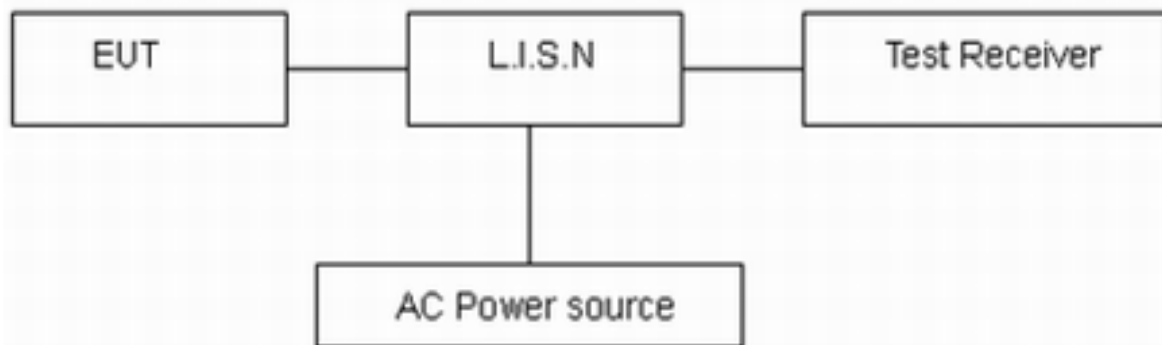

Note: AC Power source is used to change the voltage 110V/60Hz.

Limits

Frequency (MHz)	Conducted Limits(dBμV)	
	Quasi-peak	Average
0.15 - 0.5	66 to 56 *	56 to 46*
0.5 - 5	56	46
5 - 30	60	50

*: Decreases with the logarithm of the frequency.

Measurement Uncertainty

The assessed measurement uncertainty to ensure 95% confidence level for the normal distribution is with the coverage factor $k = 1.96$, $U = 2.69$ dB.



Test Results:

Antenna 2

Following plots, Blue trace uses the peak detection and Green trace uses the average detection.

802.11b, Channel No.: 1

L Line

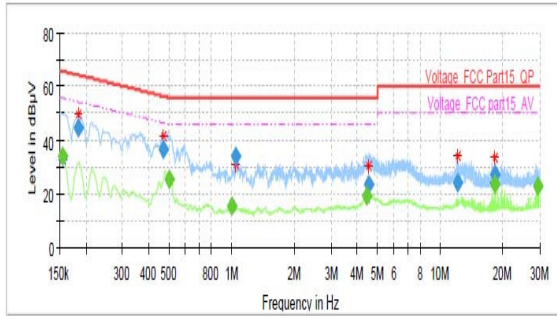

Final Result

Table with 11 columns: Frequency (MHz), QuasiPeak (dBµV), Average (dBµV), Limit (dBµV), Margin (dB), Meas. Time (ms), Bandwidth (kHz), Line, Filter, Corr. (dB). Contains 15 rows of test data for L Line.

N Line

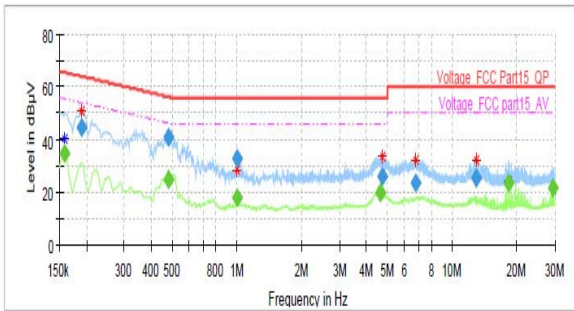

Final Result

Table with 11 columns: Frequency (MHz), QuasiPeak (dBµV), Average (dBµV), Limit (dBµV), Margin (dB), Meas. Time (ms), Bandwidth (kHz), Line, Filter, Corr. (dB). Contains 15 rows of test data for N Line.

802.11b, Channel No.: 6

L Line

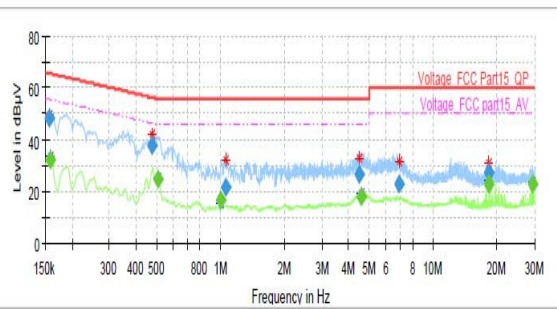

Final Result

Table with 11 columns: Frequency (MHz), QuasiPeak (dBµV), Average (dBµV), Limit (dBµV), Margin (dB), Meas. Time (ms), Bandwidth (kHz), Line, Filter, Corr. (dB). Contains 15 rows of test data for L Line.



N Line

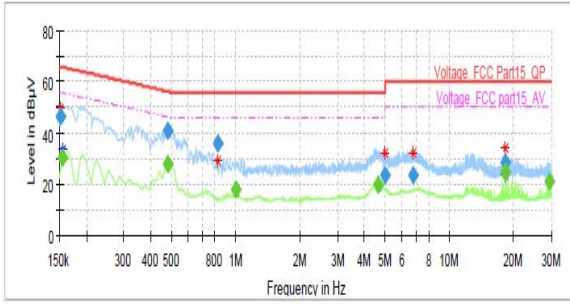

Final Result

Frequency (MHz)	QuasiPeak (dBµV)	Average (dBµV)	Limit (dBµV)	Margin (dB)	Meas. Time (ms)	Bandwidth (kHz)	Line	Filter	Corr. (dB)
0.152250	46.70	---	65.88	19.18	20.0	9.000	N	ON	19.1
0.154500	---	30.54	55.75	25.21	20.0	9.000	N	ON	19.1
0.478500	40.96	---	56.37	15.41	20.0	9.000	N	ON	19.2
0.483000	---	28.10	46.29	18.18	20.0	9.000	N	ON	19.2
0.829500	36.23	---	56.00	19.77	20.0	9.000	N	ON	19.2
1.007250	---	17.73	46.00	28.27	20.0	9.000	N	ON	19.2
4.663500	---	20.05	46.00	25.95	20.0	9.000	N	ON	19.1
5.019000	23.80	---	60.00	36.20	20.0	9.000	N	ON	19.1
6.765000	23.39	---	60.00	36.61	20.0	9.000	N	ON	19.1
18.242250	---	24.51	50.00	25.49	20.0	9.000	N	ON	19.4
18.242250	28.49	---	60.00	31.51	20.0	9.000	N	ON	19.4
29.235750	---	21.31	50.00	28.69	20.0	9.000	N	ON	19.7

802.11b, Channel No.: 11

L Line

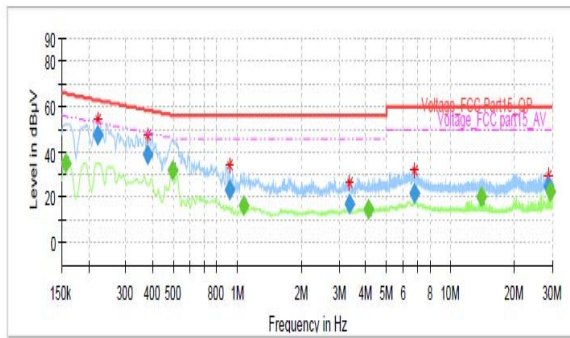

Final Result

Frequency (MHz)	QuasiPeak (dBµV)	Average (dBµV)	Limit (dBµV)	Margin (dB)	Meas. Time (ms)	Bandwidth (kHz)	Line	Filter	Corr. (dB)
0.156750	---	35.23	55.63	20.41	20.0	9.000	L1	ON	19.1
0.222000	47.37	---	62.74	15.37	20.0	9.000	L1	ON	19.1
0.379500	38.76	---	58.29	19.53	20.0	9.000	L1	ON	19.2
0.454250	---	32.15	46.10	13.94	20.0	9.000	L1	ON	19.2
0.917250	23.21	---	56.00	32.79	20.0	9.000	L1	ON	19.2
1.065750	---	16.17	46.00	29.83	20.0	9.000	L1	ON	19.2
3.351750	17.06	---	56.00	38.94	20.0	9.000	L1	ON	19.1
4.114500	---	14.76	46.00	31.24	20.0	9.000	L1	ON	19.1
6.774000	21.71	---	60.00	38.29	20.0	9.000	L1	ON	19.1
13.891750	---	19.91	50.00	30.09	20.0	9.000	L1	ON	19.5
28.686750	24.79	---	60.00	35.21	20.0	9.000	L1	ON	19.8
29.235750	---	22.86	50.00	27.14	20.0	9.000	L1	ON	19.8

N Line

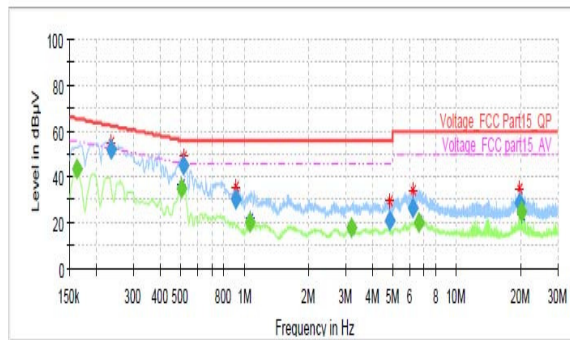

Final Result

Frequency (MHz)	QuasiPeak (dBµV)	Average (dBµV)	Limit (dBµV)	Margin (dB)	Meas. Time (ms)	Bandwidth (kHz)	Line	Filter	Corr. (dB)
0.161250	---	43.35	55.40	12.05	20.0	9.000	N	ON	19.1
0.235500	51.98	---	62.25	10.28	20.0	9.000	N	ON	19.1
0.503250	---	35.01	46.00	10.99	20.0	9.000	N	ON	19.2
0.514500	44.66	---	56.00	11.34	20.0	9.000	N	ON	19.2
0.912750	29.86	---	56.00	26.14	20.0	9.000	N	ON	19.2
1.063500	---	20.23	46.00	25.77	20.0	9.000	N	ON	19.2
3.207750	---	17.69	46.00	28.31	20.0	9.000	N	ON	19.1
4.857000	20.60	---	56.00	35.40	20.0	9.000	N	ON	19.1
6.189000	26.45	---	60.00	33.55	20.0	9.000	N	ON	19.1
6.670500	---	20.37	50.00	29.63	20.0	9.000	N	ON	19.1
19.711500	28.69	---	60.00	31.31	20.0	9.000	N	ON	19.5
20.258250	---	24.71	50.00	25.29	20.0	9.000	N	ON	19.5



802.11g, Channel No.: 1

L Line

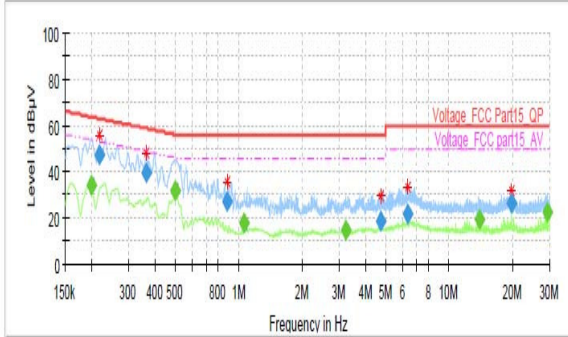

Final Result

Frequency (MHz)	QuasiPeak (dBµV)	Average (dBµV)	Limit (dBµV)	Margin (dB)	Meas. Time (ms)	Bandwidth (kHz)	Line	Filter	Corr. (dB)
0.199500	---	34.20	53.63	19.43	20.0	9.000	L1	ON	19.2
0.217500	47.12	---	62.91	15.80	20.0	9.000	L1	ON	19.2
0.363750	39.46	---	58.64	19.18	20.0	9.000	L1	ON	19.2
0.501000	---	32.10	46.00	13.90	20.0	9.000	L1	ON	19.2
0.883500	26.87	---	56.00	29.13	20.0	9.000	L1	ON	19.2
1.061250	---	17.90	46.00	28.10	20.0	9.000	L1	ON	19.2
3.241500	---	14.96	46.00	31.04	20.0	9.000	L1	ON	19.1
4.722000	18.65	---	56.00	37.35	20.0	9.000	L1	ON	19.1
6.382500	21.70	---	60.00	38.30	20.0	9.000	L1	ON	19.1
13.985250	---	19.42	50.00	30.58	20.0	9.000	L1	ON	19.5
19.709250	26.29	---	60.00	33.71	20.0	9.000	L1	ON	19.7
29.235750	---	22.52	50.00	27.48	20.0	9.000	L1	ON	19.8

N Line

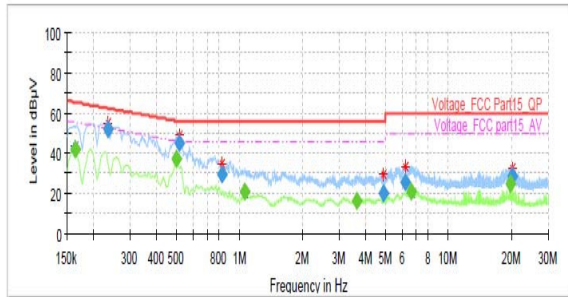

Final Result

Frequency (MHz)	QuasiPeak (dBµV)	Average (dBµV)	Limit (dBµV)	Margin (dB)	Meas. Time (ms)	Bandwidth (kHz)	Line	Filter	Corr. (dB)
0.163500	---	41.92	55.28	13.36	20.0	9.000	N	ON	19.1
0.235500	51.80	---	62.25	10.46	20.0	9.000	N	ON	19.1
0.496500	---	37.06	46.06	9.00	20.0	9.000	N	ON	19.2
0.514500	45.20	---	56.00	10.80	20.0	9.000	N	ON	19.2
0.822750	29.81	---	56.00	26.19	20.0	9.000	N	ON	19.2
1.063500	---	20.57	46.00	25.43	20.0	9.000	N	ON	19.2
3.637500	---	16.35	46.00	29.65	20.0	9.000	N	ON	19.1
4.911000	20.13	---	56.00	35.87	20.0	9.000	N	ON	19.1
6.252000	25.66	---	60.00	34.34	20.0	9.000	N	ON	19.1
6.868000	---	20.56	50.00	29.44	20.0	9.000	N	ON	19.1
19.709250	---	24.64	50.00	25.36	20.0	9.000	N	ON	19.5
20.258250	28.67	---	60.00	31.33	20.0	9.000	N	ON	19.5

802.11g, Channel No.: 6

L Line

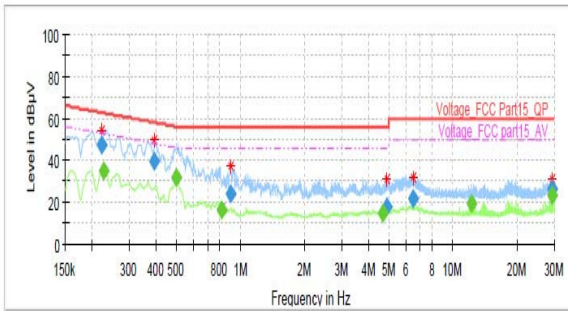

Final Result

Frequency (MHz)	QuasiPeak (dBµV)	Average (dBµV)	Limit (dBµV)	Margin (dB)	Meas. Time (ms)	Bandwidth (kHz)	Line	Filter	Corr. (dB)
0.222000	47.19	---	62.74	15.55	20.0	9.000	L1	ON	19.1
0.228500	---	35.16	52.58	17.42	20.0	9.000	L1	ON	19.1
0.393000	39.16	---	58.00	18.84	20.0	9.000	L1	ON	19.2
0.498750	---	32.14	46.02	13.88	20.0	9.000	L1	ON	19.2
0.818250	---	16.58	46.00	29.42	20.0	9.000	L1	ON	19.2
0.903750	23.98	---	56.00	32.02	20.0	9.000	L1	ON	19.2
4.699500	---	14.84	46.00	31.16	20.0	9.000	L1	ON	19.1
4.897500	18.10	---	56.00	37.90	20.0	9.000	L1	ON	19.1
6.517500	21.73	---	60.00	38.27	20.0	9.000	L1	ON	19.1
12.198750	---	19.30	50.00	30.70	20.0	9.000	L1	ON	19.4
29.235750	---	23.27	50.00	26.73	20.0	9.000	L1	ON	19.8
29.235750	26.64	---	60.00	33.36	20.0	9.000	L1	ON	19.8



N Line

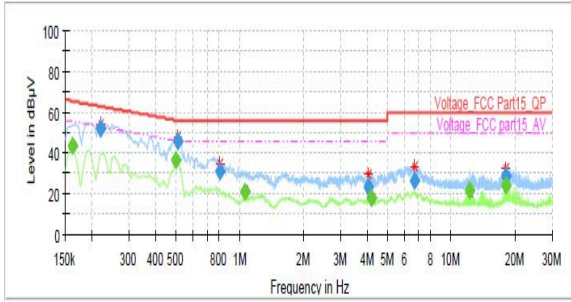

Final Result

Frequency (MHz)	QuasiPeak (dBµV)	Average (dBµV)	Limit (dBµV)	Margin (dB)	Meas. Time (ms)	Bandwidth (kHz)	Line	Filter	Corr. (dB)
0.161250	---	43.45	55.40	11.94	20.0	9.000	N	ON	19.1
0.219750	52.27	---	62.83	10.56	20.0	9.000	N	ON	19.1
0.498750	---	36.81	46.02	9.21	20.0	9.000	N	ON	19.2
0.507750	45.59	---	56.00	10.41	20.0	9.000	N	ON	19.2
0.809250	30.80	---	56.00	25.20	20.0	9.000	N	ON	19.2
1.061250	---	20.99	46.00	25.01	20.0	9.000	N	ON	19.2
4.062750	23.01	---	56.00	32.99	20.0	9.000	N	ON	19.1
4.220250	---	18.04	46.00	27.96	20.0	9.000	N	ON	19.1
6.724500	26.13	---	60.00	33.87	20.0	9.000	N	ON	19.1
12.196750	---	22.05	50.00	27.95	20.0	9.000	N	ON	19.4
18.244500	---	23.88	50.00	26.12	20.0	9.000	N	ON	19.4
18.244500	28.86	---	60.00	31.14	20.0	9.000	N	ON	19.4

802.11g, Channel No.: 11

L Line

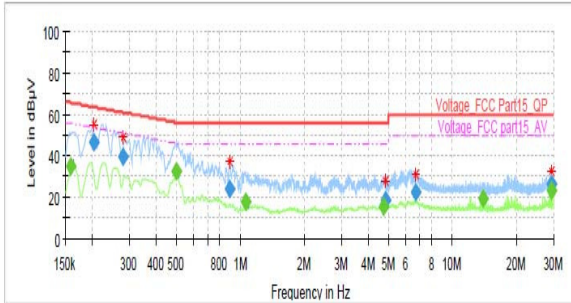

Final Result

Frequency (MHz)	QuasiPeak (dBµV)	Average (dBµV)	Limit (dBµV)	Margin (dB)	Meas. Time (ms)	Bandwidth (kHz)	Line	Filter	Corr. (dB)
0.159000	---	35.04	55.52	20.47	20.0	9.000	L1	ON	19.1
0.204000	46.19	---	63.45	17.26	20.0	9.000	L1	ON	19.2
0.278250	39.87	---	60.87	21.00	20.0	9.000	L1	ON	19.2
0.498750	---	32.41	46.02	13.61	20.0	9.000	L1	ON	19.2
0.894750	24.35	---	56.00	31.65	20.0	9.000	L1	ON	19.2
1.061250	---	17.56	46.00	28.44	20.0	9.000	L1	ON	19.2
4.731000	---	15.28	46.00	30.72	20.0	9.000	L1	ON	19.1
4.823250	18.56	---	56.00	37.44	20.0	9.000	L1	ON	19.1
6.699750	22.79	---	60.00	37.21	20.0	9.000	L1	ON	19.1
13.985250	---	19.18	50.00	30.82	20.0	9.000	L1	ON	19.5
29.235750	---	23.36	50.00	26.64	20.0	9.000	L1	ON	19.8
29.235750	26.71	---	60.00	33.29	20.0	9.000	L1	ON	19.8

N Line

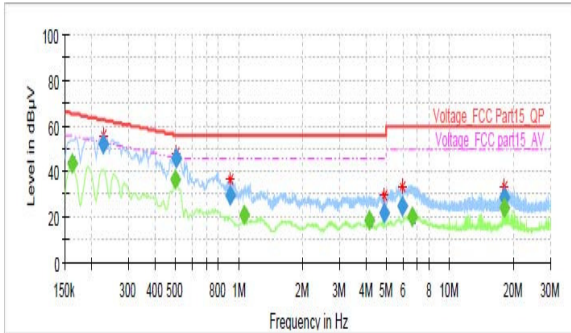

Final Result

Frequency (MHz)	QuasiPeak (dBµV)	Average (dBµV)	Limit (dBµV)	Margin (dB)	Meas. Time (ms)	Bandwidth (kHz)	Line	Filter	Corr. (dB)
0.161250	---	43.55	55.40	11.85	20.0	9.000	N	ON	19.1
0.226500	52.07	---	62.58	10.51	20.0	9.000	N	ON	19.1
0.501000	---	36.53	46.00	9.47	20.0	9.000	N	ON	19.2
0.503250	45.67	---	56.00	10.33	20.0	9.000	N	ON	19.2
0.906000	29.59	---	56.00	26.41	20.0	9.000	N	ON	19.2
1.061250	---	20.94	46.00	25.07	20.0	9.000	N	ON	19.2
4.168500	---	18.48	46.00	27.52	20.0	9.000	N	ON	19.1
4.881750	21.67	---	56.00	34.33	20.0	9.000	N	ON	19.1
5.984250	24.93	---	60.00	35.07	20.0	9.000	N	ON	19.1
6.639000	---	19.90	50.00	30.10	20.0	9.000	N	ON	19.1
18.244500	---	24.30	50.00	25.70	20.0	9.000	N	ON	19.4
18.244500	28.93	---	60.00	31.07	20.0	9.000	N	ON	19.4



802.11n(HT20), Channel No.: 1

L Line

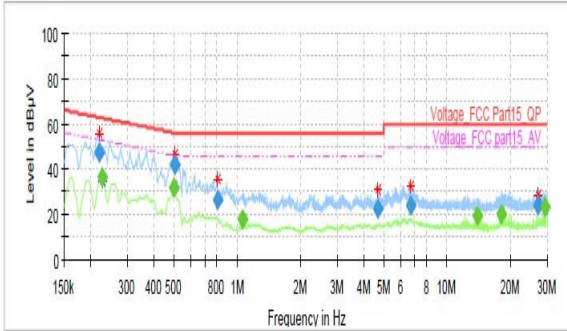

Final Result

Table with 10 columns: Frequency (MHz), QuasiPeak (dBµV), Average (dBµV), Limit (dBµV), Margin (dB), Meas. Time (ms), Bandwidth (kHz), Line, Filter, Corr. (dB). Contains 15 rows of test data for L Line.

N Line

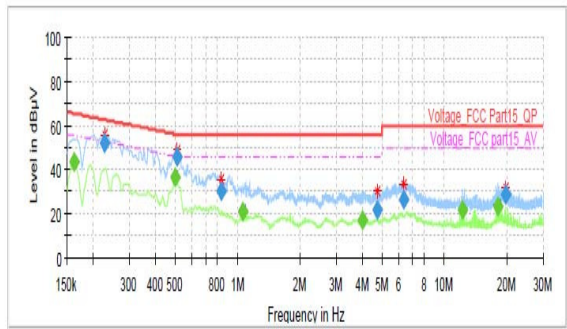

Final Result

Table with 10 columns: Frequency (MHz), QuasiPeak (dBµV), Average (dBµV), Limit (dBµV), Margin (dB), Meas. Time (ms), Bandwidth (kHz), Line, Filter, Corr. (dB). Contains 15 rows of test data for N Line.

802.11n(HT20), Channel No.: 6

L Line

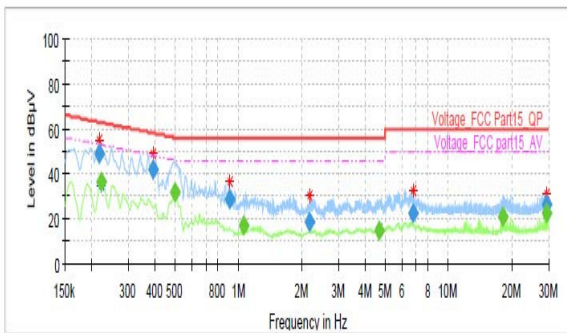

Final Result

Table with 10 columns: Frequency (MHz), QuasiPeak (dBµV), Average (dBµV), Limit (dBµV), Margin (dB), Meas. Time (ms), Bandwidth (kHz), Line, Filter, Corr. (dB). Contains 15 rows of test data for L Line.

N Line

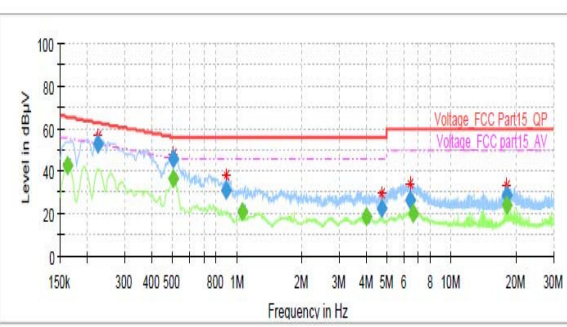

Final Result

Table with 10 columns: Frequency (MHz), QuasiPeak (dBµV), Average (dBµV), Limit (dBµV), Margin (dB), Meas. Time (ms), Bandwidth (kHz), Line, Filter, Corr. (dB). Contains 15 rows of test data for N Line.



802.11n(HT20), Channel No.: 11

L Line

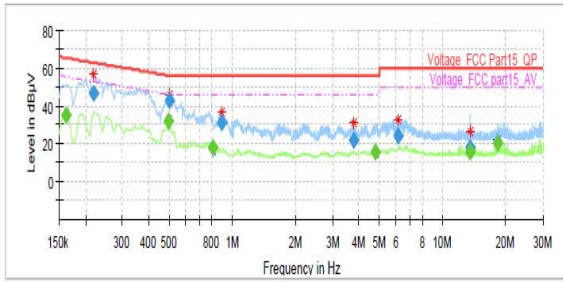

Final Result

Table with 10 columns: Frequency (MHz), QuasiPeak (dBµV), Average (dBµV), Limit (dBµV), Margin (dB), Meas. Time (ms), Bandwidth (kHz), Line, Filter, Corr. (dB). Contains 15 rows of test data for L Line.

N Line

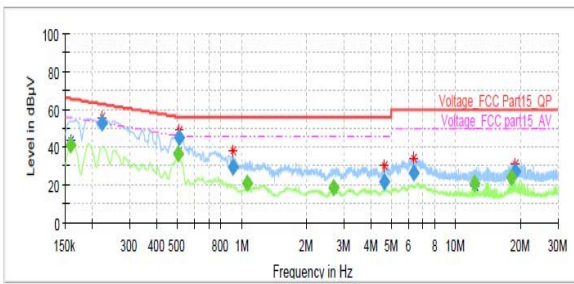

Final Result

Table with 10 columns: Frequency (MHz), QuasiPeak (dBµV), Average (dBµV), Limit (dBµV), Margin (dB), Meas. Time (ms), Bandwidth (kHz), Line, Filter, Corr. (dB). Contains 15 rows of test data for N Line.

802.11n(HT40), Channel No.: 3

L Line

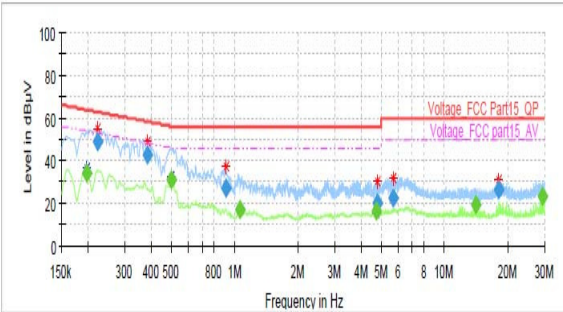

Final Result

Table with 10 columns: Frequency (MHz), QuasiPeak (dBµV), Average (dBµV), Limit (dBµV), Margin (dB), Meas. Time (ms), Bandwidth (kHz), Line, Filter, Corr. (dB). Contains 15 rows of test data for L Line.

N Line

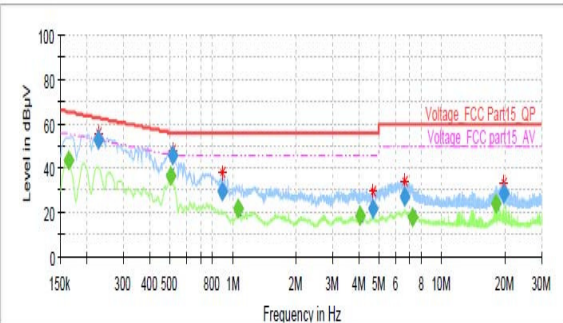

Final Result

Table with 10 columns: Frequency (MHz), QuasiPeak (dBµV), Average (dBµV), Limit (dBµV), Margin (dB), Meas. Time (ms), Bandwidth (kHz), Line, Filter, Corr. (dB). Contains 15 rows of test data for N Line.

802.11n(HT40), Channel No.: 6

L Line

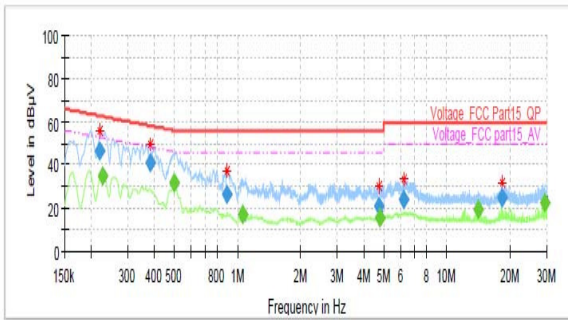

Final Result

Frequency (MHz)	QuasiPeak (dBµV)	Average (dBµV)	Limit (dBµV)	Margin (dB)	Meas. Time (ms)	Bandwidth (kHz)	Line	Filter	Corr. (dB)
0.219750	46.31	---	62.83	16.52	20.0	9.000	L1	ON	19.1
0.226500	---	35.18	52.58	17.40	20.0	9.000	L1	ON	19.1
0.381750	41.08	---	58.24	17.16	20.0	9.000	L1	ON	19.2
0.501000	---	31.43	46.00	14.57	20.0	9.000	L1	ON	19.2
0.885750	26.21	---	56.00	29.79	20.0	9.000	L1	ON	19.2
1.061250	---	16.93	46.00	29.07	20.0	9.000	L1	ON	19.2
4.731000	20.99	---	56.00	35.01	20.0	9.000	L1	ON	19.1
4.776000	---	15.56	46.00	30.44	20.0	9.000	L1	ON	19.1
6.202500	24.15	---	60.00	35.85	20.0	9.000	L1	ON	19.1
14.088750	---	19.40	50.00	30.60	20.0	9.000	L1	ON	19.5
18.308250	24.84	---	60.00	35.16	20.0	9.000	L1	ON	19.5
29.235750	---	22.79	50.00	27.21	20.0	9.000	L1	ON	19.8

N Line

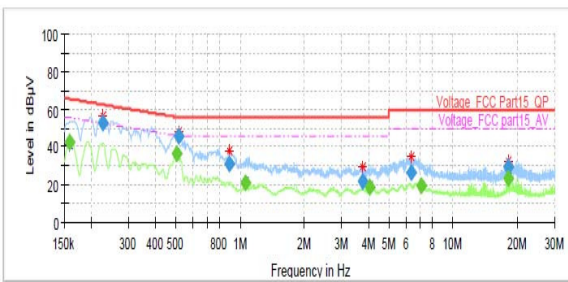

Final Result

Frequency (MHz)	QuasiPeak (dBµV)	Average (dBµV)	Limit (dBµV)	Margin (dB)	Meas. Time (ms)	Bandwidth (kHz)	Line	Filter	Corr. (dB)
0.159000	---	42.52	55.52	13.00	20.0	9.000	N	ON	19.1
0.226500	52.69	---	62.58	9.89	20.0	9.000	N	ON	19.1
0.503250	---	36.60	46.00	9.40	20.0	9.000	N	ON	19.2
0.514500	45.39	---	56.00	10.61	20.0	9.000	N	ON	19.2
0.888000	30.84	---	56.00	25.16	20.0	9.000	N	ON	19.2
1.061250	---	21.13	46.00	24.87	20.0	9.000	N	ON	19.2
3.794500	22.02	---	56.00	33.98	20.0	9.000	N	ON	19.1
4.065000	---	18.45	46.00	27.55	20.0	9.000	N	ON	19.1
6.378000	26.16	---	60.00	33.84	20.0	9.000	N	ON	19.1
7.127250	---	19.62	50.00	30.38	20.0	9.000	N	ON	19.2
18.244500	---	23.48	50.00	26.52	20.0	9.000	N	ON	19.4
18.244500	29.12	---	60.00	30.88	20.0	9.000	N	ON	19.4

802.11n(HT40), Channel No.: 9

L Line

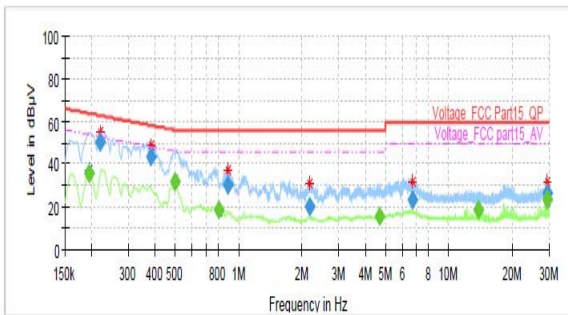

Final Result

Frequency (MHz)	QuasiPeak (dBµV)	Average (dBµV)	Limit (dBµV)	Margin (dB)	Meas. Time (ms)	Bandwidth (kHz)	Line	Filter	Corr. (dB)
0.195000	---	35.68	53.82	18.14	20.0	9.000	L1	ON	19.2
0.219750	50.35	---	62.83	12.48	20.0	9.000	L1	ON	19.1
0.381750	43.05	---	58.24	15.19	20.0	9.000	L1	ON	19.2
0.501000	---	31.79	46.00	14.21	20.0	9.000	L1	ON	19.2
0.804750	---	18.99	46.00	27.01	20.0	9.000	L1	ON	19.2
0.885750	29.96	---	56.00	26.04	20.0	9.000	L1	ON	19.2
2.170500	20.36	---	56.00	35.64	20.0	9.000	L1	ON	19.1
4.688000	---	15.70	46.00	30.30	20.0	9.000	L1	ON	19.1
6.722250	23.40	---	60.00	36.60	20.0	9.000	L1	ON	19.1
13.778250	---	18.41	50.00	31.59	20.0	9.000	L1	ON	19.5
29.235750	---	23.13	50.00	26.87	20.0	9.000	L1	ON	19.8
29.235750	26.47	---	60.00	33.53	20.0	9.000	L1	ON	19.8

N Line

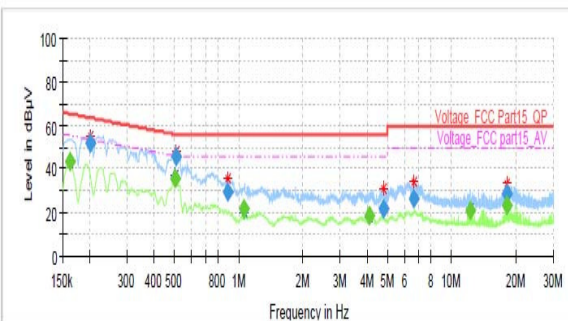

Final Result

Frequency (MHz)	QuasiPeak (dBµV)	Average (dBµV)	Limit (dBµV)	Margin (dB)	Meas. Time (ms)	Bandwidth (kHz)	Line	Filter	Corr. (dB)
0.161250	---	43.75	55.40	11.65	20.0	9.000	N	ON	19.1
0.201750	52.32	---	63.54	11.22	20.0	9.000	N	ON	19.2
0.503250	---	35.48	46.00	10.52	20.0	9.000	N	ON	19.2
0.510000	45.66	---	56.00	10.34	20.0	9.000	N	ON	19.2
0.894750	29.65	---	56.00	26.35	20.0	9.000	N	ON	19.2
1.061250	---	21.55	46.00	24.45	20.0	9.000	N	ON	19.2
4.119000	---	18.67	46.00	27.33	20.0	9.000	N	ON	19.1
4.805250	21.97	---	56.00	34.03	20.0	9.000	N	ON	19.1
6.612000	26.50	---	60.00	33.50	20.0	9.000	N	ON	19.1
12.198750	---	21.23	50.00	28.77	20.0	9.000	N	ON	19.4
18.242250	28.68	---	60.00	31.32	20.0	9.000	N	ON	19.4
18.244500	---	23.49	50.00	26.51	20.0	9.000	N	ON	19.4

6. Main Test Instruments

Name	Type/Model	Manufacturer	Serial Number	Calibration Date	Expiration Time
Spectrum Analyzer	FSV30	R&S	100815	2015-12-17	2016-12-16
EMI Test Receiver	ESCI	R&S	100948	2016-06-01	2017-05-31
TRILOG Broadband Antenna	VULB 9163	Schwarzbeck	9163-201	2014-12-06	2017-12-05
Double Ridged Waveguide Horn Antenna	HF907	R&S	100126	2014-12-06	2017-12-05
Loop Antenna	FMZB1519	SCHWARZBECK	1519-047	2014-02-19	2017-02-18
Standard Gain Horn	3160-09	ETS-Lindgren	00102644	2015-01-30	2018-01-29
EMI Test Receiver	ESCS30	R&S	100138	2015-12-17	2016-12-16
LISN	ENV216	R&S	101171	2013-12-18	2016-12-17
Spectrum Analyzer	N9010A	Agilent	MY47191109	2016-05-21	2017-05-20
MOB COMMS DC SUPPLY	66319D	Agilent	MY43004105	2016-05-21	2017-05-20
Peak Power Meter	U2021XA	Keysight	MY55240003	2016-06-26	2017-06-25
RF Cable	SMA 15cm	Agilent	0001	2016-08-05	2017-08-04

*****END OF REPORT *****

ANNEX A: EUT Appearance and Test Setup

A.1 EUT Appearance



Front Side



Back Side

a: EUT



b: Adapter



c: Cable

Picture 1 EUT and Accessory

A.2 Test Setup

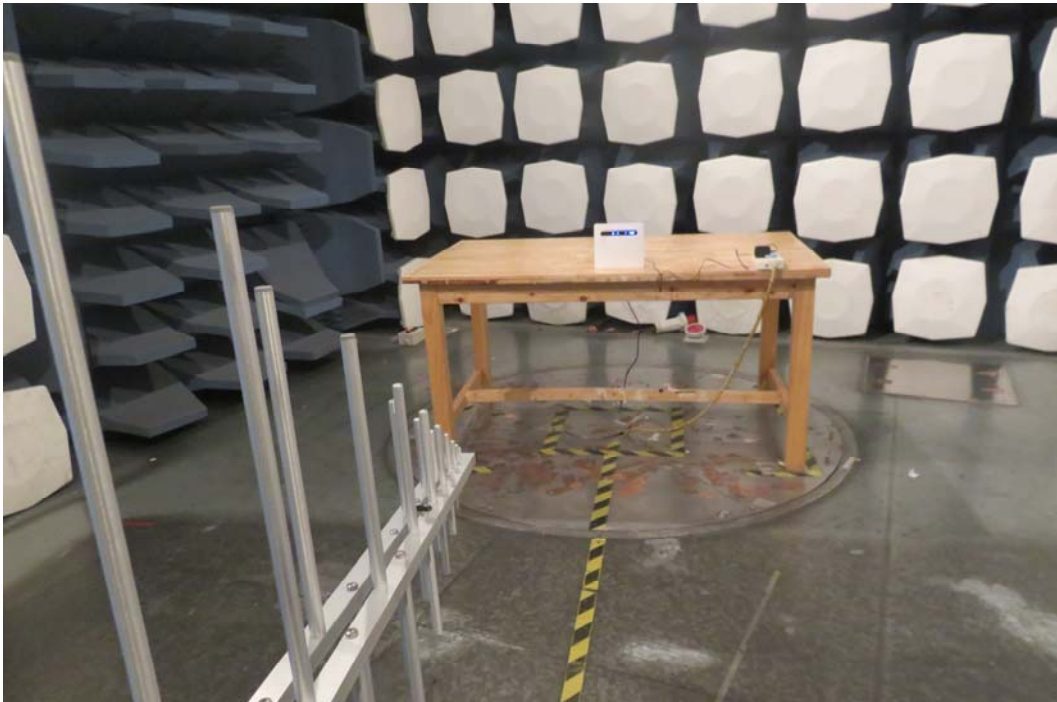

30MHz-1GHz



Above 1GHz

Picture 2 Radiated Emission Test Setup



Picture 3 Conducted Emission Test Setup