

Test report

303472-1TRFWL

Date of issue: October 31, 2017

Applicant:

Intracom S.A. Telecom Solutions

Product:

Point-to-Point Gigabit Radio 60 GHz

Model:

StreetNode 6250 PtP

Part number:

SN6250T-F-1-L-G-AC

Part number variant:

SN6250T-F-1-H-G-DC

FCC ID:

2AHZC-SN6250F12HW16

Specification:

FCC 47 CFR Part 15 Subpart C, §15.255

Operation within the band 57–64 GHz.

Test location

Company name	Nemko Canada Inc.
Address	303 River Road
City	Ottawa
Province	Ontario
Postal code	K1V 1H2
Country	Canada
Telephone	+1 613 737 9680
Facsimile	+1 613 737 9691
Toll free	+1 800 563 6336
Website	www.nemko.com
Site number	FCC: CA2040 (3 m semi anechoic chamber)

Tested by	Andrey Adelberg, Senior Wireless/EMC Specialist
Reviewed by	Kevin Rose, Wireless/EMC Specialist
Date	October 31, 2017
Signature of reviewer	

Limits of responsibility

Note that the results contained in this report relate only to the items tested and were obtained in the period between the date of initial receipt of samples and the date of issue of the report.

This test report has been completed in accordance with the requirements of ISO/IEC 17025. All results contain in this report are within Nemko Canada's ISO/IEC 17025 accreditation.

Copyright notification

Nemko Canada Inc. authorizes the applicant to reproduce this report provided it is reproduced in its entirety and for use by the company's employees only. Any use which a third party makes of this report, or any reliance on or decisions to be made based on it, are the responsibility of such third parties.

Nemko Canada Inc. accepts no responsibility for damages, if any, suffered by any third party as a result of decisions made or actions based on this report.

© Nemko Canada Inc.

Table of contents

Table of contents	3
Section 1. Report summary	4
1.1 Applicant and manufacturer	4
1.2 Test specifications	4
1.3 Test methods	4
1.4 Statement of compliance	4
1.5 Exclusions	4
1.6 Test report revision history	4
Section 2. Summary of test results	5
2.1 FCC Part 15 Subpart C test results	5
Section 3. Equipment under test (EUT) details	6
3.1 Sample information	6
3.2 EUT information	6
3.3 Technical information	6
3.4 Product description and theory of operation	6
3.5 EUT exercise details	6
3.6 EUT setup diagram	7
Section 4. Engineering considerations	8
4.1 Modifications incorporated in the EUT	8
4.2 Technical judgment	8
4.3 Deviations from laboratory tests procedures	8
Section 5. Test conditions	9
5.1 Atmospheric conditions	9
5.2 Power supply range	9
Section 6. Measurement uncertainty	10
6.1 Uncertainty of measurement	10
Section 7. Test equipment	11
7.1 Test equipment list	11
Section 8. Testing data	12
8.1 FCC 15.207(a) AC power line conducted emissions limits	12
8.2 FCC 15.255(b) and (d) Conducted output power and EIRP requirements	16
8.3 FCC 15.255(c) Limits on spurious emissions	19
8.4 FCC 15.255(d)(1) 6 dB bandwidth	29
8.5 FCC 15.255(e) Frequency stability	31
Section 9. Block diagrams of test set-ups	33
9.1 Radiated emissions set-up for frequencies below 1 GHz	33
9.2 Radiated emissions set-up for frequencies above 1 GHz	34
9.3 Conducted emissions set-up	34
9.4 Conducted power measurement set-up	35

Section 1. Report summary

1.1 Applicant and manufacturer

Company name	Intracom S.A. Telecom Solutions
Address	19.7 km Markopoulou Ave.
City	Peania
Province/State	Athens
Postal/Zip code	GR-19002
Country	Greece

1.2 Test specifications

FCC 47 CFR Part 15, Subpart C, Clause 15.255	Operation within the band 57–64 GHz
--	-------------------------------------

1.3 Test methods

ANSI C63.10 v 2013	American National Standard for Procedures for Compliance Testing of Unsilenced Wireless Devices
--------------------	---

1.4 Statement of compliance

In the configuration tested, the EUT was found compliant.

Testing was completed against all relevant requirements of the test standard. Results obtained indicate that the product under test complies in full with the requirements tested. The test results relate only to the items tested.

See “Summary of test results” for full details.

1.5 Exclusions

None

1.6 Test report revision history

Revision #	Details of changes made to test report
TRF	Original report issued

Section 2. Summary of test results

2.1 FCC Part 15 Subpart C test results

Part	Test description	Verdict
§15.207(a)	Conducted limits	Pass
§15.203	Antenna requirement	Pass ¹
§15.255(b) and (d)	Conducted output power and EIRP requirements	Pass
§15.255(c)	Limits on spurious emissions	Pass
§15.255(d)(1)	6 dB BW	Pass
§15.255(e)	Frequency stability	Pass

Notes: ¹ The EUT is a professionally installed device and the installer is responsible for ensuring that the proper antenna is employed.

Section 3. Equipment under test (EUT) details

3.1 Sample information

Receipt date	June 5, 2017
Nemko sample ID number	1, 2, 3, 4

3.2 EUT information

Product name	Point-to-Point Gigabit Radio 60 GHz
Model	StreetNode 6250 PtP
Part number	SN6250T-F-1-L-G-AC
Part number variant*	SN6250T-F-1-H-G-DC
Serial number	321701413530 (Low radio) and 321701413537 (High radio)

* - Part number variants: **SN6250T-F-1-u-z-vv**: u: **L** (Low radio), **H** (High radio); z: **G** (Grey), **C** (Charcoal Gray); vv: (Supply voltage) **AC** or **DC**

3.3 Technical information

Frequency band	57–64 GHz
Frequency Min	57.275 GHz (Low radio), 60.775 GHz (High radio)
Frequency Max	58.275 GHz (Low radio), 61.775 GHz (High radio)
Channel BW	250 MHz
Type of modulation	4-QAM, 16-QAM, 32-QAM, 64-QAM and 128-QAM
Emission classification (F1D, G1D, D1D)	W7D
Power requirements	AC: 90–240 V _{AC} 50/60 Hz or DC: –40.5 to –60 V _{DC}
Antenna information	Internal proprietary antenna with 34 dBi gain The EUT is professionally installed.

3.4 Product description and theory of operation

StreetNode 6250 PTP is an innovative compact all-outdoor native packet radio operating in the 57–64 GHz band (V-Band). It can be used to implement highly-flexible Point-to-Point Microwave (PtP MW) backhaul topologies, reaching challenging small-cell locations and delivering best-in-class connectivity at street level. StreetNode™ 6250 PTP satisfies every critical aspect of 3G and 4G/LTE/LTE-A small-cell backhaul, providing high capacity, low latency, automated provisioning and high availability, while optimizing the small-cell business case economics.

3.5 EUT exercise details

EUT was controlled from PC using Windows Terminal to set the transmission on desired channel and modulation type.

3.6 EUT setup diagram

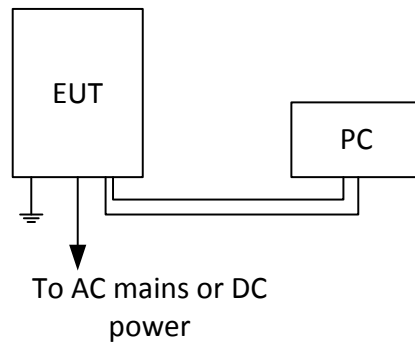

Figure 3.6-1: Setup diagram

Section 4. Engineering considerations

4.1 Modifications incorporated in the EUT

There were no modifications performed to the EUT during this assessment.

4.2 Technical judgment

None

4.3 Deviations from laboratory tests procedures

No deviations were made from laboratory procedures.

Section 5. Test conditions

5.1 Atmospheric conditions

Temperature	15–30 °C
Relative humidity	20–75 %
Air pressure	860–1060 mbar

When it is impracticable to carry out tests under these conditions, a note to this effect stating the ambient temperature and relative humidity during the tests shall be recorded and stated.

5.2 Power supply range

The normal test voltage for equipment to be connected to the mains shall be the nominal mains voltage. For the purpose of the present document, the nominal voltage shall be the declared voltage, or any of the declared voltages $\pm 5\%$, for which the equipment was designed.



Section 6. Measurement uncertainty

6.1 Uncertainty of measurement

Measurement uncertainty budgets for the tests are detailed below. Measurement uncertainty calculations assume a coverage factor of $K = 2$ with 95% certainty.

Test name	Measurement uncertainty, dB
All antenna port measurements	0.55
Conducted spurious emissions	1.13
Radiated spurious emissions	3.78
AC power line conducted emissions	3.55

Section 7. Test equipment

7.1 Test equipment list

Table 7.1-1: Equipment list

Equipment	Manufacturer	Model no.	Asset no.	Cal cycle	Next cal.
3 m EMI test chamber	TDK	SAC-3	FA002047	1 year	Dec. 1/17
Flush mount turntable	Sunol	FM2022	FA002082	—	NCR
Controller	Sunol	SC104V	FA002060	—	NCR
Antenna mast	Sunol	TLT2	FA002061	—	NCR
AC Power source	Chenwa	2700M-10k	FA002716	—	VOU
DC Power source	Ametek	SGA80X125C-0AAA	FA002737	—	VOU
Spectrum analyzer	Rohde & Schwarz	FSU	FA001877	1 year	Jul. 18/18
LISN	Rohde & Schwarz	ENV216	FA002023	1 year	May 19/18
Horn with Preamp	ETS-Lindgren	3117-PA	FA002840	1 year	Nov. 11/17
Bilog antenna (20–3000 MHz)	Sunol	JB3	FA002108	1 year	June 27/18
Horn antenna (18–40 GHz)	EMCO	3116	FA001847	1 year	June 27/18
Pre-amplifier (18–26 GHz)	Narda	BBS-1826N612	FA001550	—	VOU
Pre-amplifier (26–40 GHz)	Narda	DBL-2640N610	FA001556	—	VOU
Spectrum analyzer	Rohde & Schwarz	FSU	FA001877	1 year	Jul. 18/18
40–60 GHz Harmonic mixer	OML	WR19 M19HWD	FA002322	3 year	May. 16/19
40–60 GHz Standard gain horn	Millitech	U SGH-19	FA002322	—	VOU
60–90 GHz Harmonic mixer	OML	WR12 M12HWD	FA001524	3 year	May. 16/19
60–90 GHz Standard gain horn	Millitech	U SGH-12	FA001524	—	VOU
90–140 GHz Harmonic mixer	OML	WR08 M08HWD	FA001525	3 year	May. 16/19
90–140 GHz Standard gain horn	Millitech	U SGH-08	FA001525	—	VOU
140–220 GHz Harmonic mixer	OML	WR05 M05HWD	FA001526	3 year	May. 16/19
140–220 GHz Standard gain horn	Millitech	U SGH-05	FA001526	—	VOU
Power meter	Agilent	E4418B	FA001678	1 year	May 15/18
Temperature chamber	Thermotron	SM-16C	FA001030	1 year	NCR
Broadband diode detector	QStar	QEA-FBFBVP	1416007	—	NCR
3 GHz scope	Tektronix	TDS694c	FA002505	1 year	Oct. 18/17
Waveguide power sensor 50–75 GHz	Keysight	ATV8486A	77393	1 year	Apr 7/18

Note: NCR - no calibration required, VOU - verify on use

Section 8. Testing data

8.1 FCC 15.207(a) AC power line conducted emissions limits

8.1.1 Definitions and limits

Except as shown in paragraphs (b) and (c) of this section, for an intentional radiator that is designed to be connected to the public utility (AC) power line, the radio frequency voltage that is conducted back onto the AC power line on any frequency or frequencies, within the band 150 kHz to 30 MHz, shall not exceed the limits in the following table, as measured using a 50 μ H/50 Ω line impedance stabilization network (LISN). Compliance with the provisions of this paragraph shall be based on the measurement of the radio frequency voltage between each power line and ground at the power terminal. The lower limit applies at the boundary between the frequency ranges.

Table 8.1-1: Conducted emissions limit

Frequency of emission, MHz	Conducted limit, dB μ V	
	Quasi-peak	Average**
0.15–0.5	66 to 56*	56 to 46*
0.5–5	56	46
5–30	60	50

Note: * - The level decreases linearly with the logarithm of the frequency.
 ** - A linear average detector is required.

8.1.2 Test summary

Test date	August 10, 2017	Temperature	21 °C
Test engineer	Andrey Adelberg	Air pressure	1010 mbar
Verdict	Pass	Relative humidity	36 %

8.1.3 Observations, settings and special notes

The EUT was set up as tabletop configuration.

The spectral scan has been corrected with transducer factors (i.e. cable loss, LISN factors, and attenuators) for determination of compliance.

A preview measurement was generated with the receiver in continuous scan mode. Emissions detected within 6 dB or above limit were re-measured with the appropriate detector against the correlating limit and recorded as the final measurement.

Receiver settings for preview measurements:

Resolution bandwidth	9 kHz
Video bandwidth	30 kHz
Detector mode	Peak and Average
Trace mode	Max Hold
Measurement time	1000 ms

Receiver settings for final measurements:

Resolution bandwidth	9 kHz
Video bandwidth	30 kHz
Detector mode	Quasi-Peak and Average
Trace mode	Max Hold
Measurement time	1000 ms

8.1.4 Test data

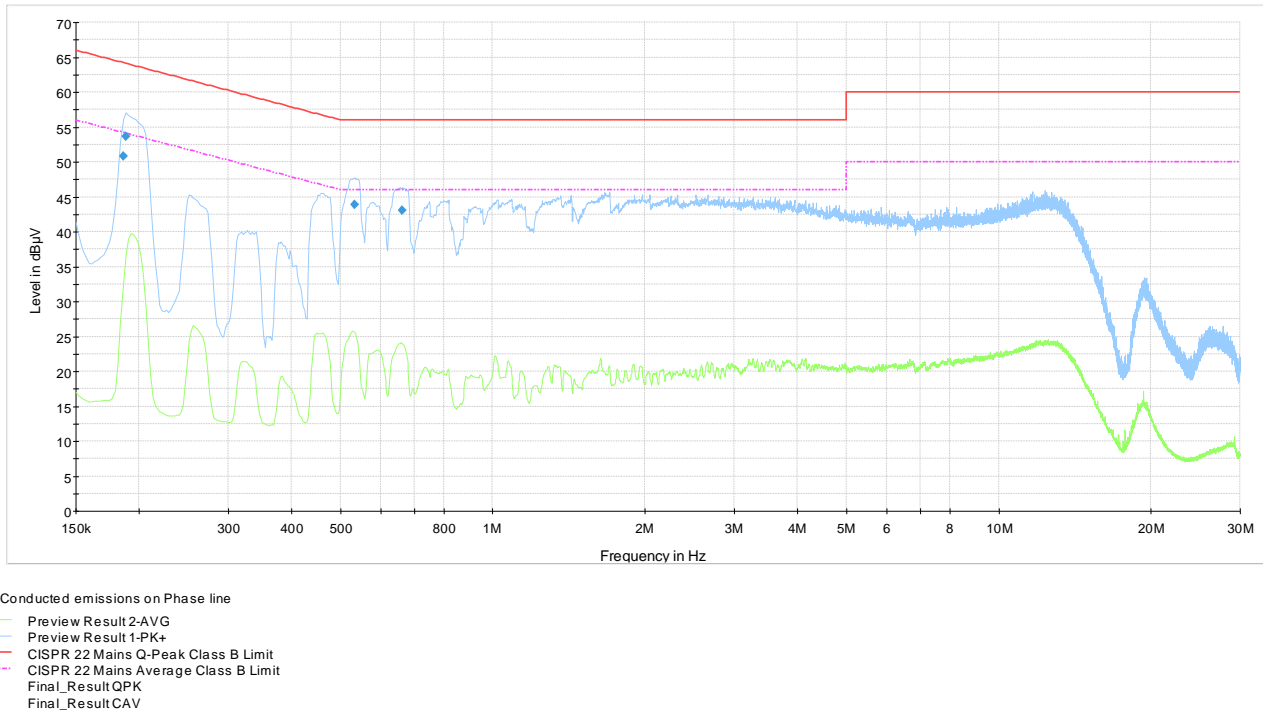

Plot 8.1-1: Conducted emissions on phase line

Table 8.1-2: Quasi-Peak conducted emissions results on phase line

Frequency, MHz	Q-Peak result, dBµV	Limit, dBµV	Margin, dB	Meas. Time, ms	Bandwidth, kHz	Line	Filter	Correction, dB
0.186000	50.88	64.21	13.33	100	9	Phase	ON	9.6
0.188250	53.65	64.11	10.46	100	9	Phase	ON	9.6
0.532500	43.83	56.00	12.17	100	9	Phase	ON	9.4
0.663000	43.06	56.00	12.94	100	9	Phase	ON	9.4

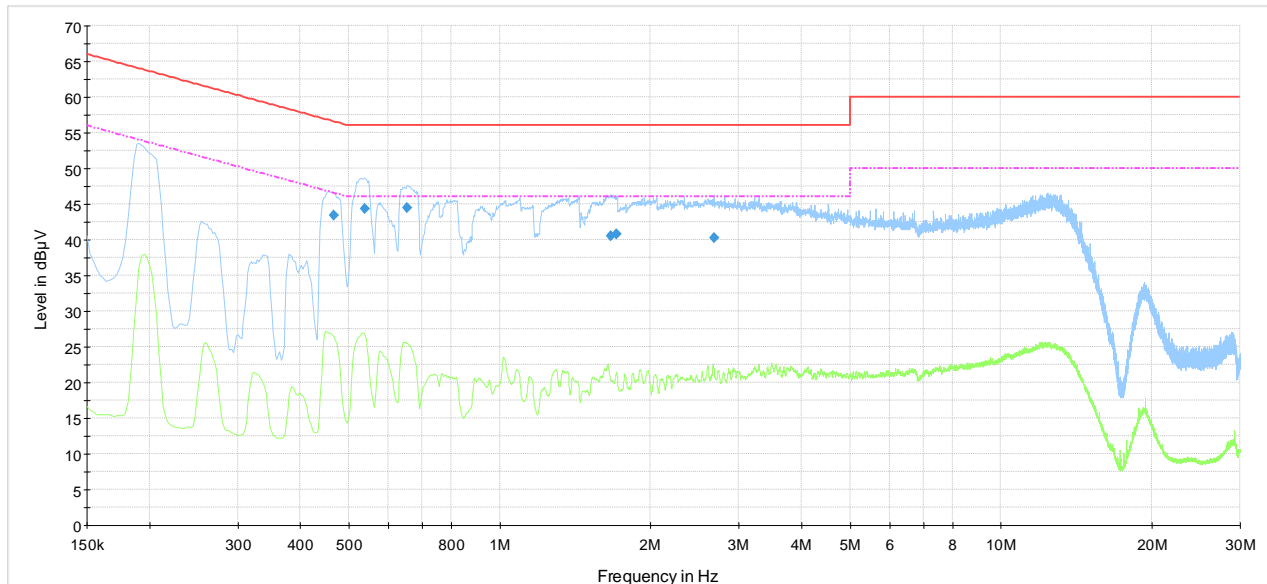

Conducted emissions on Neutral line

- Preview Result 2-AVG
- Preview Result 1-PK+
- CISPR 22 Mains Q-Peak Class B Limit
- - - CISPR 22 Mains Average Class B Limit
- ◆ Final_Result QPK
- ◆ Final_Result CAV

Plot 8.1-2: Conducted emissions on neutral line

Table 8.1-3: Quasi-Peak conducted emissions results on neutral line

Frequency, MHz	Q-Peak result, dBµV	Limit, dBµV	Margin, dB	Meas. Time, ms	Bandwidth, kHz	Line	Filter	Correction, dB
0.467250	43.41	56.56	13.15	100	9	Neutral	ON	9.4
0.537000	44.34	56.00	11.66	100	9	Neutral	ON	9.4
0.654000	44.43	56.00	11.57	100	9	Neutral	ON	9.4
1.666500	40.55	56.00	15.45	100	9	Neutral	ON	9.4
1.711500	40.77	56.00	15.23	100	9	Neutral	ON	9.4
2.672250	40.26	56.00	15.74	100	9	Neutral	ON	9.4

8.2 FCC 15.255(b) and (d) Conducted output power and EIRP requirements

8.2.1 Definitions and limits

- (b) Within the 57–71 GHz band, emission levels shall not exceed the following equivalent isotropically radiated power (EIRP):
- (ii) For fixed point-to-point transmitters located outdoors, the average power of any emission shall not exceed 82 dBm, and shall be reduced by 2 dB for every dB that the antenna gain is less than 51 dBi. The peak power of any emission shall not exceed 85 dBm, and shall be reduced by 2 dB for every dB that the antenna gain is less than 51 dBi.
- (A) The provisions in this paragraph for reducing transmit power based on antenna gain shall not require that the power levels be reduced below the limits specified in paragraph (b)(1)(i) of this section.
- (B) The provisions of §15.204(c)(2) and (4) that permit the use of different antennas of the same type and of equal or less directional gain do not apply to intentional radiator systems operating under this provision. In lieu thereof, intentional radiator systems shall be certified using the specific antenna(s) with which the system will be marketed and operated. Compliance testing shall be performed using the highest gain and the lowest gain antennas for which certification is sought and with the intentional radiator operated at its maximum available output power level. The responsible party, as defined in §2.909 of this chapter, shall supply a list of acceptable antennas with the application for certification.
- (4) The peak power shall be measured with an RF detector that has a detection bandwidth that encompasses the 57–71 GHz band and has a video bandwidth of at least 10 MHz. The average emission levels shall be measured over the actual time period during which transmission occurs.
- (d) Except as specified paragraph (d)(1) of this section, the peak transmitter conducted output power shall not exceed 500 mW. Depending on the gain of the antenna, it may be necessary to operate the intentional radiator using a lower peak power output power in order to comply with the EIRP limits specified in paragraph (b) of this section.
- (1) Transmitters with an emission bandwidth of less than 100 MHz must limit their peak transmitter conducted output power to the product of 500 mW times their emission bandwidth divided by 100 MHz. For the purposes of this paragraph, emission bandwidth is defined as the instantaneous frequency range occupied by a steady state radiated signal with modulation, outside which the radiated power spectral density never exceeds 6 dB below the maximum radiated power spectral density in the band, as measured with a 100-kHz resolution bandwidth spectrum analyzer. The center frequency must be stationary during the measurement interval, even if not stationary during normal operation (e.g., for frequency hopping devices).
- (2) Peak transmitter conducted output power shall be measured with an RF detector that has a detection bandwidth that encompasses the 57–71 GHz band and that has a video bandwidth of at least 10 MHz.
- (3) For purposes of demonstrating compliance with this paragraph, corrections to the transmitter conducted output power may be made due to the antenna and circuit loss.

8.2.2 Test summary

Test date	August 15, 2017	Temperature	22 °C
Test engineer	Andrey Adelberg	Air pressure	1005 mbar
Verdict	Pass	Relative humidity	32 %

8.2.3 Observations, settings and special notes

EUT is an outdoor device with an emission bandwidth of more than 100 MHz. Average EIRP limit was calculated as follows: $82 \text{ dBm} - 2 \times (51 \text{ dBi} - 34 \text{ dBi}) = 48 \text{ dBm}$. Average output power was measured with power meter. Diode detector was used to find peak to average ratio, then peak level was calculated.

8.2.4 Test data

Table 8.2-1: Conducted average output power and EIRP results for SN6250T-F-1-L-G-AC with 4-QAM modulation

Frequency, GHz	Average output power, dBm	Antenna gain, dBi	EIRP, dBm	Average EIRP limit, dBm	Margin, dB
57.275	1.31	34.00	35.31	48.00	12.69
57.775	1.01	34.00	35.01	48.00	12.99
58.275	1.19	34.00	35.19	48.00	12.81

Table 8.2-2: Conducted peak output power and EIRP results for SN6250T-F-1-L-G-AC with 4-QAM modulation

Frequency, GHz	Peak output power, dBm	Peak output power limit, dBm	Margin, dB	Antenna gain, dBi	EIRP, dBm	EIRP limit, dBm	Margin, dB
57.275	2.11	27.00	24.89	34.00	36.11	51.00	14.89
57.775	1.79	27.00	25.21	34.00	35.79	51.00	15.21
58.275	1.27	27.00	25.73	34.00	35.27	51.00	15.73

Note: EIRP limit was calculated as follows: $85 \text{ dBm} - 2 \times (51 \text{ dBi} - 34 \text{ dBi}) = 51 \text{ dBm}$

Table 8.2-3: Conducted average output power and EIRP results for SN6250T-F-1-L-G-AC with 128-QAM modulation

Frequency, GHz	Average output power, dBm	Antenna gain, dBi	EIRP, dBm	Average EIRP limit, dBm	Margin, dB
57.275	1.33	34.00	35.33	48.00	12.67
57.775	0.98	34.00	34.98	48.00	13.02
58.275	1.34	34.00	35.34	48.00	12.66

Table 8.2-4: Conducted peak output power and EIRP results for SN6250T-F-1-L-G-AC with 128-QAM modulation

Frequency, GHz	Peak output power, dBm	Peak output power limit, dBm	Margin, dB	Antenna gain, dBi	EIRP, dBm	EIRP limit, dBm	Margin, dB
57.275	2.55	27.00	24.45	34.00	36.55	51.00	14.45
57.775	2.22	27.00	24.78	34.00	36.22	51.00	14.78
58.275	2.58	27.00	24.42	34.00	36.58	51.00	14.42

Note: EIRP limit was calculated as follows: $85 \text{ dBm} - 2 \times (51 \text{ dBi} - 34 \text{ dBi}) = 51 \text{ dBm}$



Table 8.2-5: Conducted average output power and EIRP results for SN6250T-F-1-H-G-DC with 4-QAM modulation

Frequency, GHz	Average output power, dBm	Antenna gain, dBi	EIRP, dBm	Average EIRP limit, dBm	Margin, dB
60.775	2.81	34.00	36.81	48.00	11.19
61.275	2.19	34.00	36.19	48.00	11.81
61.775	3.03	34.00	37.03	48.00	10.97

Table 8.2-6: Conducted peak output power and EIRP results for SN6250T-F-1-H-G-DC with 4-QAM modulation

Frequency, GHz	Peak output power, dBm	Peak output power limit, dBm	Margin, dB	Antenna gain, dBi	EIRP, dBm	EIRP limit, dBm	Margin, dB
60.775	3.64	27.00	23.36	34.00	37.64	51.00	13.36
61.275	2.95	27.00	24.05	34.00	36.95	51.00	14.05
61.775	3.88	27.00	23.12	34.00	37.88	51.00	13.12

Note: EIRP limit was calculated as follows: 85 dBm – 2 × (51 dBi – 34 dBi) = 51 dBm

Table 8.2-7: Conducted average output power and EIRP results for SN6250T-F-1-H-G-DC with 128-QAM modulation

Frequency, GHz	Average output power, dBm	Antenna gain, dBi	EIRP, dBm	Average EIRP limit, dBm	Margin, dB
60.775	3.17	34.00	37.17	48.00	10.83
61.275	2.15	34.00	36.15	48.00	11.85
61.775	2.46	34.00	36.46	48.00	11.54

Table 8.2-8: Conducted peak output power and EIRP results for SN6250T-F-1-H-G-DC with 128-QAM modulation

Frequency, GHz	Peak output power, dBm	Peak output power limit, dBm	Margin, dB	Antenna gain, dBi	EIRP, dBm	EIRP limit, dBm	Margin, dB
60.775	4.37	27.00	22.63	34.00	38.37	51.00	12.63
61.275	3.34	27.00	23.66	34.00	37.34	51.00	13.66
61.775	3.72	27.00	23.28	34.00	37.72	51.00	13.28

Note: EIRP limit was calculated as follows: 85 dBm – 2 × (51 dBi – 34 dBi) = 51 dBm

Table 8.2-9: Peak measurement details, sample calculation

RMS power measurement, dBm	RMS power measurement, mW	RMS voltage, V _{RMS}	Peak voltage, V _{Peak}	Peak power equivalent, mW	Peak power, dBm
3.17	2.075	14.25	18.80	2.737	4.37

Note: The measurement was performed using a diode detector with its output connected to an oscilloscope. RMS and Peak voltage measurements were performed and peak power was extrapolated from the peak voltage measurement.

Sample calculation: 2.075 mW input power yielded 14.25 V_{RMS}; Peak measurement of the same signal was 18.820 V_{Peak}. Peak power was extrapolated using the following equation: P_{Peak} = P_{RMS} × (V_{Peak} / V_{RMS})

8.3 FCC 15.255(c) Limits on spurious emissions

8.3.1 Definitions and limits

- (1) The power density of any emissions outside the 57–64 GHz band shall consist solely of spurious emissions.
- (2) Radiated emissions below 40 GHz shall not exceed the general limits in §15.209.
- (3) Between 40 GHz and 200 GHz, the level of these emissions shall not exceed 90 pW/cm² (85.3 dBμV/m) at a distance of 3 meters.
- (4) The levels of the spurious emissions shall not exceed the level of the fundamental emission.

Table 8.3-1: FCC §15.209 – Radiated emission limits

Frequency, MHz	Field strength of emissions		Measurement distance, m
	μV/m	dBμV/m	
30–88	100	40.0	3
88–216	150	43.5	3
216–960	200	46.0	3
above 960	500	54.0	3

Notes: In the emission table above, the tighter limit applies at the band edges.

For frequencies above 1 GHz the limit on peak RF emissions is 20 dB above the maximum permitted average emission limit applicable to the equipment under test

Table 8.3-2: FCC restricted frequency bands

MHz	MHz	MHz	GHz
0.090–0.110	16.42–16.423	399.9–410	4.5–5.15
0.495–0.505	16.69475–16.69525	608–614	5.35–5.46
2.1735–2.1905	16.80425–16.80475	960–1240	7.25–7.75
4.125–4.128	25.5–25.67	1300–1427	8.025–8.5
4.17725–4.17775	37.5–38.25	1435–1626.5	9.0–9.2
4.20725–4.20775	73–74.6	1645.5–1646.5	9.3–9.5
6.215–6.218	74.8–75.2	1660–1710	10.6–12.7
6.26775–6.26825	108–121.94	1718.8–1722.2	13.25–13.4
6.31175–6.31225	123–138	2200–2300	14.47–14.5
8.291–8.294	149.9–150.05	2310–2390	15.35–16.2
8.362–8.366	156.52475–156.52525	2483.5–2500	17.7–21.4
8.37625–8.38675	156.7–156.9	2690–2900	22.01–23.12
8.41425–8.41475	162.0125–167.17	3260–3267	23.6–24.0
12.29–12.293	167.72–173.2	3332–3339	31.2–31.8
12.51975–12.52025	240–285	3345.8–3358	36.43–36.5
12.57675–12.57725	322–335.4	3600–4400	Above 38.6
13.36–13.41			

8.3.2 Test summary

Test date	August 8, 2017	Temperature	22 °C
Test engineer	Andrey Adelberg	Air pressure	1009 mbar
Verdict	Pass	Relative humidity	32 %

8.3.3 Observations, settings and special notes

The spectrum was searched from 30 MHz to the 220 GHz.
 Radiated measurements were performed at a distance of 3 m for frequencies below 18 GHz, 1 m within 18–40 GHz, and 3 cm for frequencies above 40 GHz.
 Limit line calculation for frequencies above 40 GHz: $85.3 \text{ dB}\mu\text{V/m} + 20 \times \text{Log}(3/0.03) = 85.3 + 40 \text{ dB} = 125.3 \text{ dB}\mu\text{V/m}$

Spectrum analyser settings for radiated measurements within restricted bands below 1 GHz:

Resolution bandwidth	100 kHz
Video bandwidth	300 kHz
Detector mode	Peak
Trace mode	Max Hold

Spectrum analyser settings for peak radiated measurements within restricted bands above 1 GHz:

Resolution bandwidth	1 MHz
Video bandwidth	3 MHz
Detector mode	Peak
Trace mode	Max Hold

8.3.4 Test data

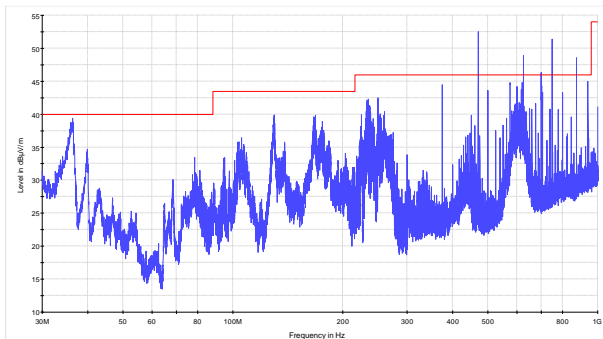

Figure 8.3-1: Spurious emissions below 1 GHz for SN6250T-F-1-L-G-AC, low channel

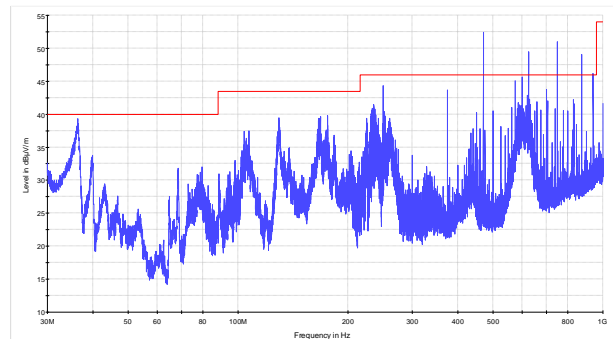

Figure 8.3-2: Spurious emissions below 1 GHz for SN6250T-F-1-L-G-AC, high channel

Note: EUT is a Class A equipment for unintentional radiation. All radiated peaks measured and shown on the plots above are digital emissions and therefore exempt from the requirements of RF spurious emissions.

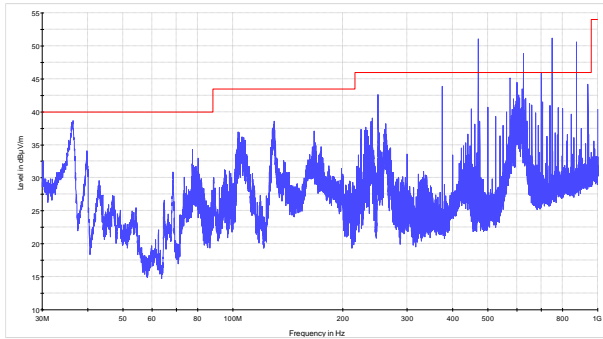

Figure 8.3-3: Spurious emissions below 1 GHz for SN6250T-F-1-L-G-AC, transmitter turned off (digital emissions)

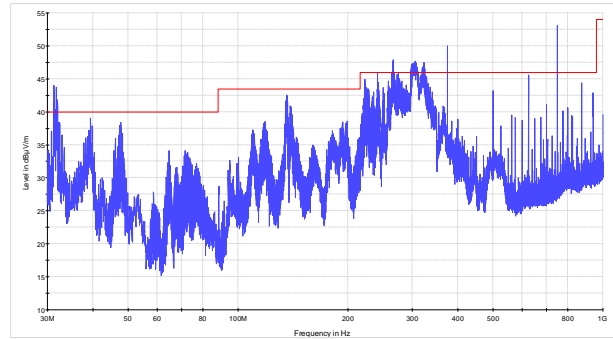

Figure 8.3-4: Spurious emissions below 1 GHz for SN6250T-F-1-H-G-DC, low channel

Note: EUT is a Class A equipment for unintentional radiation. All radiated peaks measured and shown on the plots above are digital emissions and therefore exempt from the requirements of RF spurious emissions.

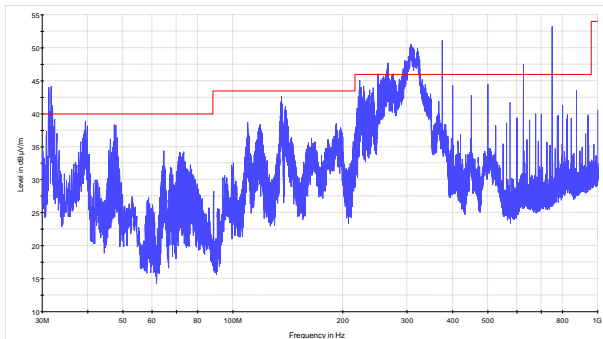

Figure 8.3-5: Spurious emissions below 1 GHz for SN6250T-F-1-H-G-DC, high channel

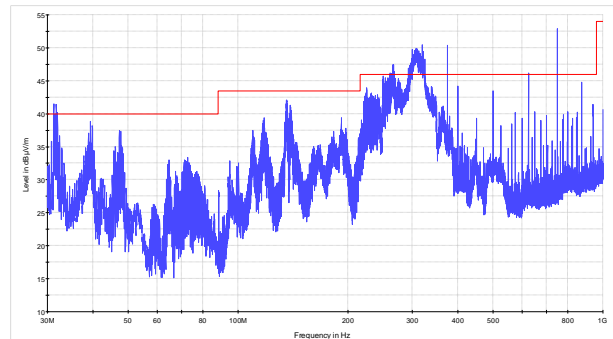

Figure 8.3-6: Spurious emissions below 1 GHz for SN6250T-F-1-H-G-DC, transmitter turned off

Note: EUT is a Class A equipment for unintentional radiation. All radiated peaks measured and shown on the plots above are digital emissions and therefore exempt from the requirements of RF spurious emissions.

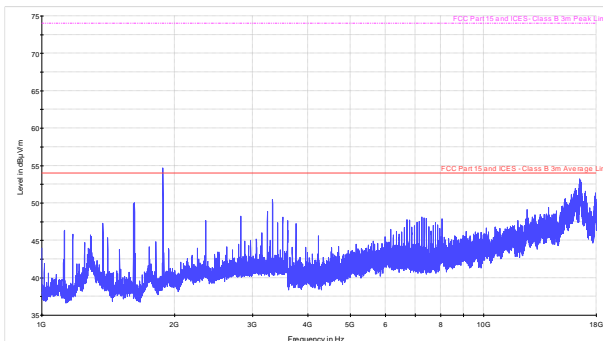

Figure 8.3-7: Spurious emissions within 1–18 GHz for SN6250T-F-1-L-G-AC, low channel

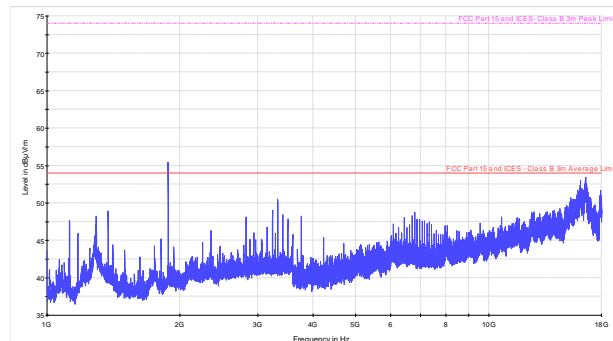

Figure 8.3-8: Spurious emissions within 1–18 GHz for SN6250T-F-1-L-G-AC, high channel

Note: EUT is a Class A equipment for unintentional radiation. All radiated peaks measured and shown on the plots above are digital emissions and therefore exempt from the requirements of RF spurious emissions.

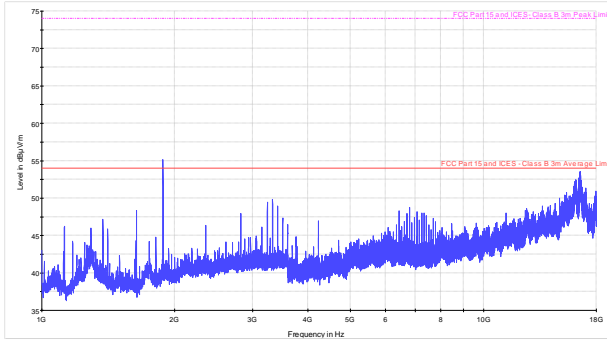

Figure 8.3-9: Spurious emissions within 1–18 GHz for SN6250T-F-1-L-G-AC, transmitter turned off

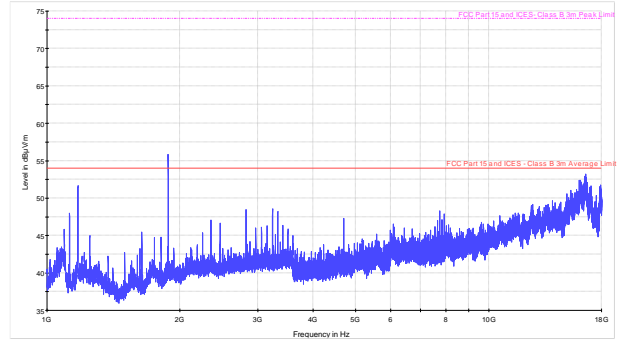

Figure 8.3-10: Spurious emissions within 1–18 GHz for SN6250T-F-1-H-G-DC, low channel

Note: EUT is a Class A equipment for unintentional radiation. All radiated peaks measured and shown on the plots above are digital emissions and therefore exempt from the requirements of RF spurious emissions.

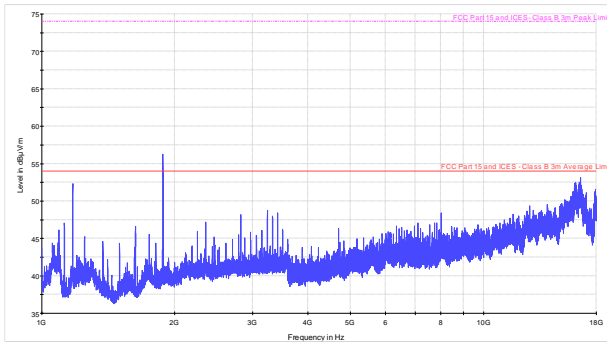

Figure 8.3-11: Spurious emissions within 1–18 GHz for SN6250T-F-1-H-G-DC, high channel

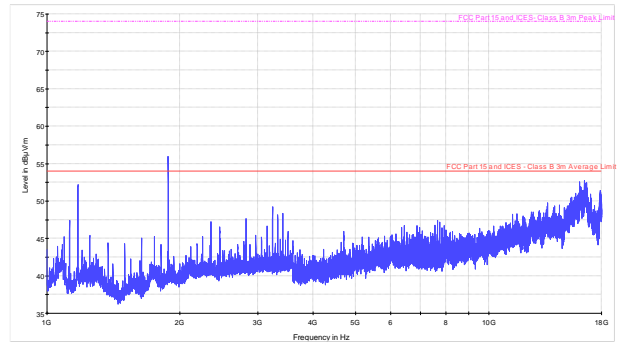

Figure 8.3-12: Spurious emissions within 1–18 GHz for SN6250T-F-1-H-G-DC, transmitter turned off

Note: EUT is a Class A equipment for unintentional radiation. All radiated peaks measured and shown on the plots above are digital emissions and therefore exempt from the requirements of RF spurious emissions.

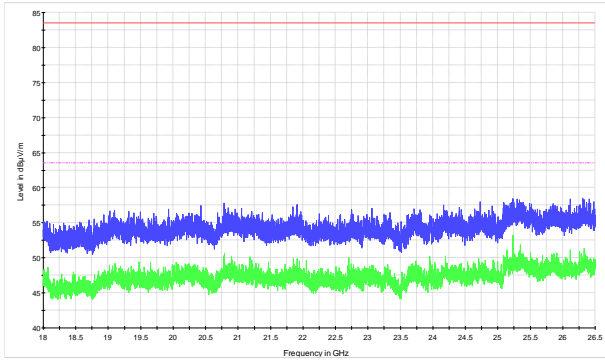

Figure 8.3-13: Spurious emissions within 18–26.5 GHz for SN6250T-F-1-L-G-AC, low channel

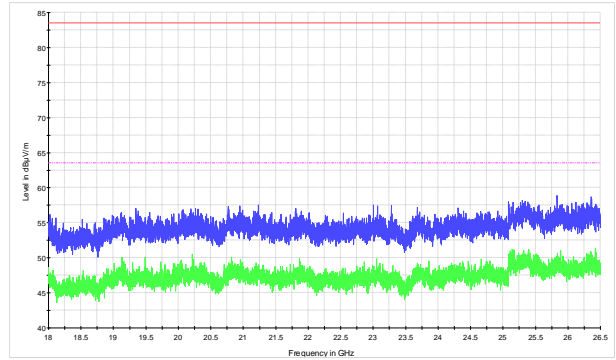

Figure 8.3-14: Spurious emissions within 18–26.5 GHz for SN6250T-F-1-L-G-AC, high channel

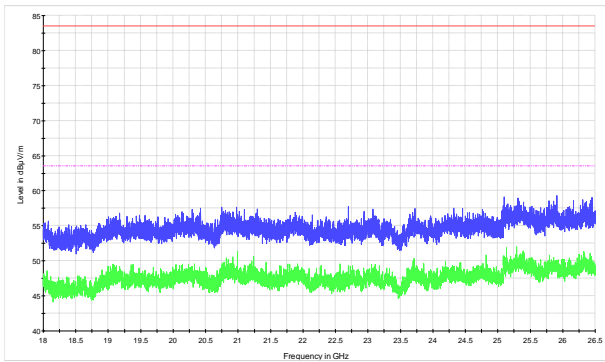

Figure 8.3-15: Spurious emissions within 18–26.5 GHz for SN6250T-F-1-H-G-DC, low channel

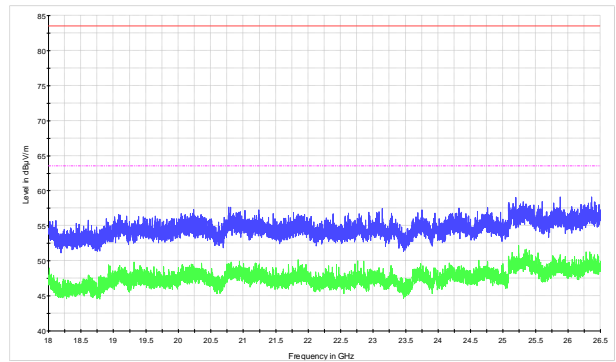

Figure 8.3-16: Spurious emissions within 26.5–40 GHz for SN6250T-F-1-H-G-DC, high channel

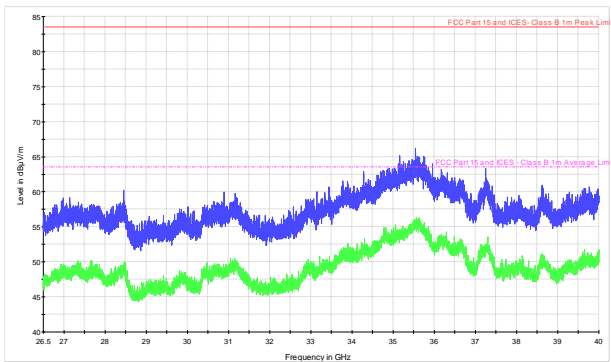

Figure 8.3-17: Spurious emissions within 26.5–40 GHz for SN6250T-F-1-L-G-AC, low channel

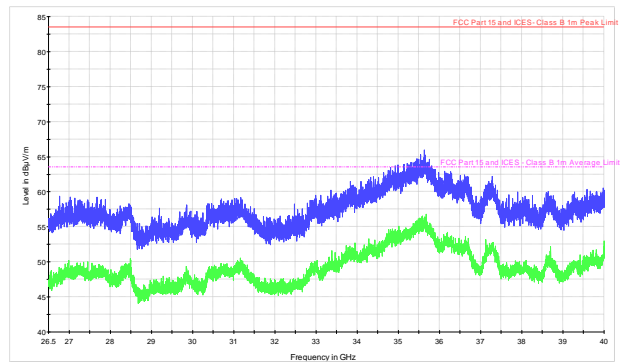

Figure 8.3-18: Spurious emissions within 26.5–40 GHz for SN6250T-F-1-L-G-AC, high channel

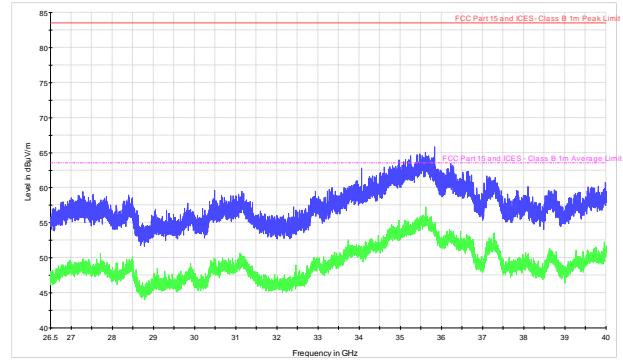
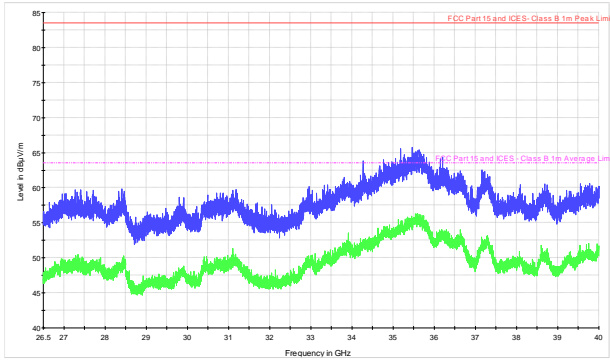
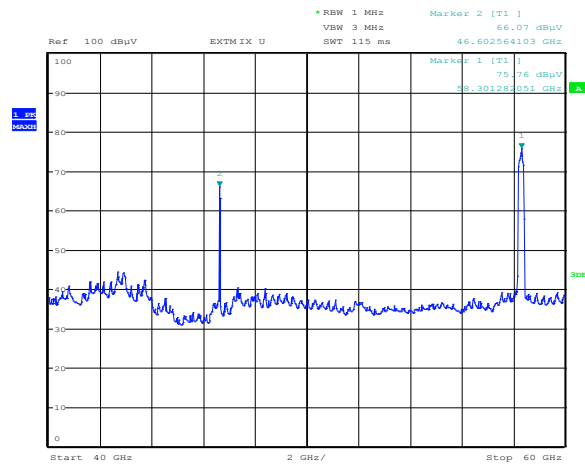
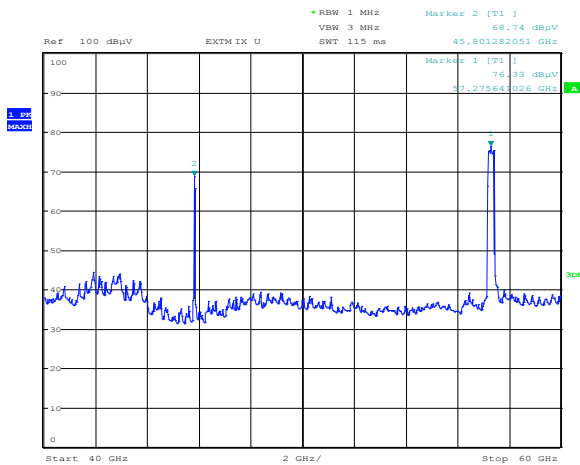

Figure 8.3-19: Spurious emissions within 26.5–40 GHz for SN6250T-F-1-H-G-DC, low channel

Figure 8.3-20: Spurious emissions within 26.5–40 GHz for SN6250T-F-1-H-G-DC, high channel



Date: 9.AUG.2017 12:20:43

Date: 9.AUG.2017 12:19:57

Figure 8.3-21: Spurious emissions within 40–60 GHz for SN6250T-F-1-L-G-AC, low channel

Figure 8.3-22: Spurious emissions within 40–60 GHz for SN6250T-F-1-L-G-AC, high channel

Note: The spur in the plots is the image of the intermodulation product of the external mixer (except for fundamental peak). LO within this frequency range is between 11.5 to 12.5 GHz. These are not actual emissions of the EUT.

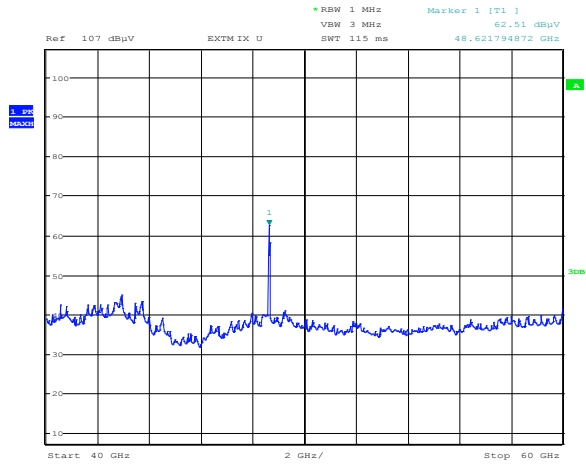

Date: 8.AUG.2017 16:42:01

Figure 8.3-23: Spurious emissions within 40–60 GHz for SN6250T-F-1-H-G-DC, low channel

Note: limit line is at 125 dB μ V/m (including distance correction).

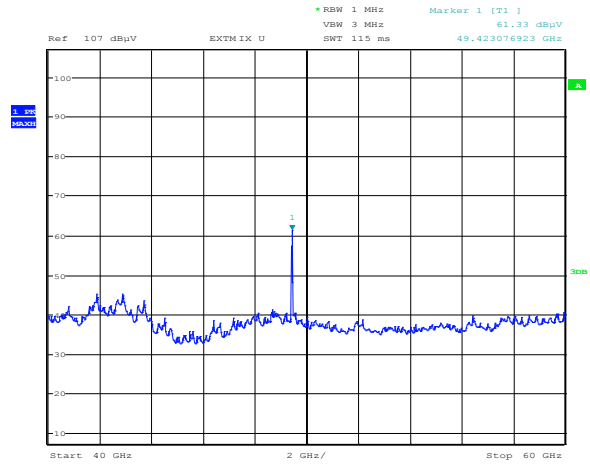

Date: 8.AUG.2017 16:41:38

Figure 8.3-24: Spurious emissions within 40–60 GHz for SN6250T-F-1-H-G-DC, high channel

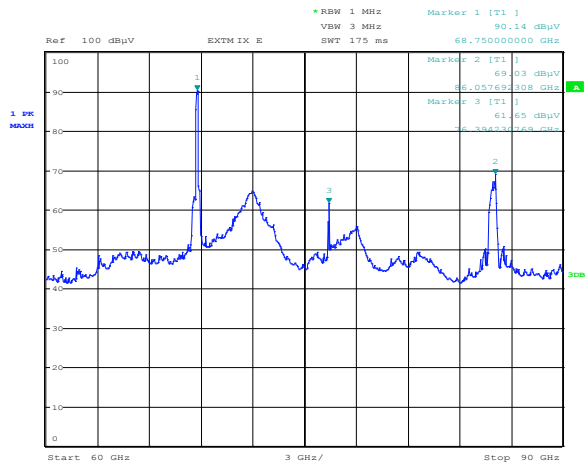

Date: 9.AUG.2017 11:36:24

Figure 8.3-25: Spurious emissions within 60–90 GHz for SN6250T-F-1-L-G-AC, low channel

Note: limit line is at 125 dB μ V/m (including distance correction).

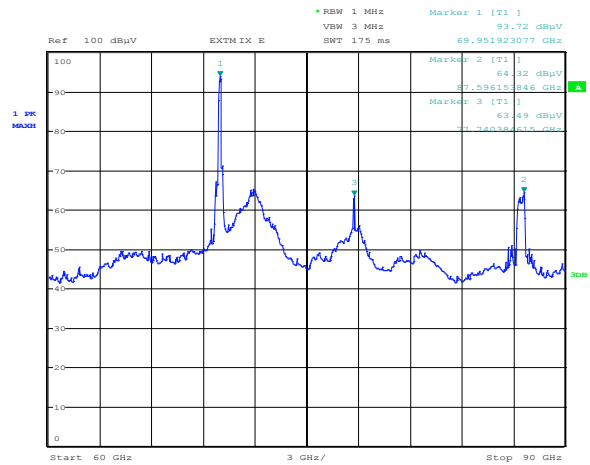

Date: 9.AUG.2017 11:30:29

Figure 8.3-26: Spurious emissions within 60–90 GHz for SN6250T-F-1-L-G-AC, high channel

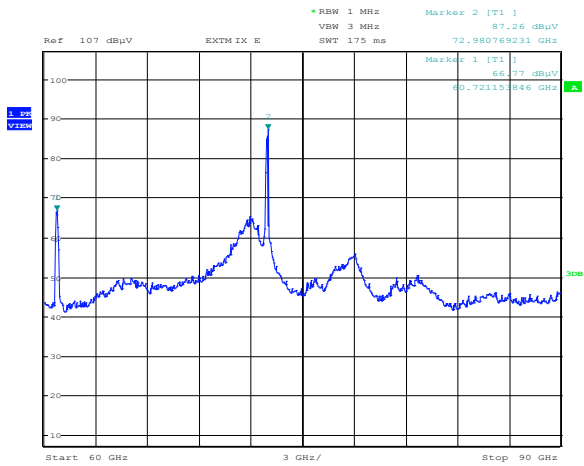

Date: 8.AUG.2017 16:25:47

Figure 8.3-27: Spurious emissions within 60–90 GHz for SN6250T-F-2-H-G-DC, low channel

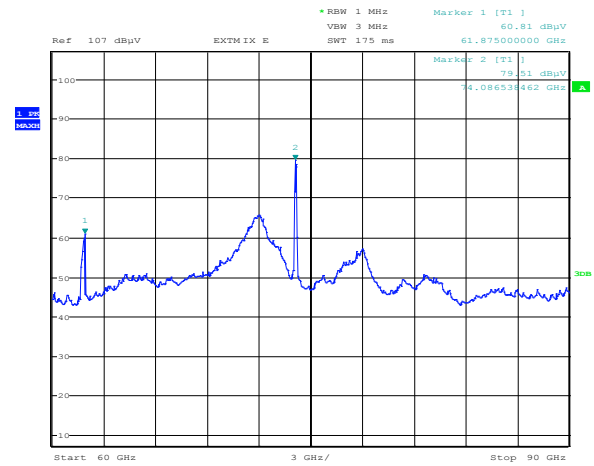

Date: 8.AUG.2017 16:32:39

Figure 8.3-28: Spurious emissions within 60–90 GHz for SN6250T-F-2-H-G-DC, high channel

Note: The spur in the plots is the image of the intermodulation product of the external mixer (except for fundamental peak). LO within this frequency range is between 11.5 to 12.5 GHz. These are not actual emissions of the EUT.

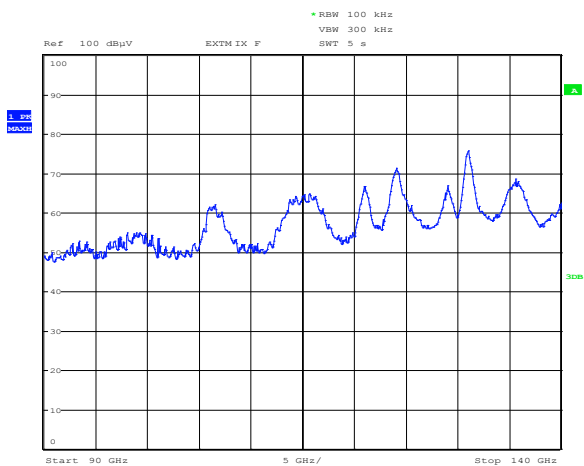

Date: 9.AUG.2017 12:02:01

Figure 8.3-29: Spurious emissions within 90–140 GHz for SN6250T-F-1-L-G-AC, low channel

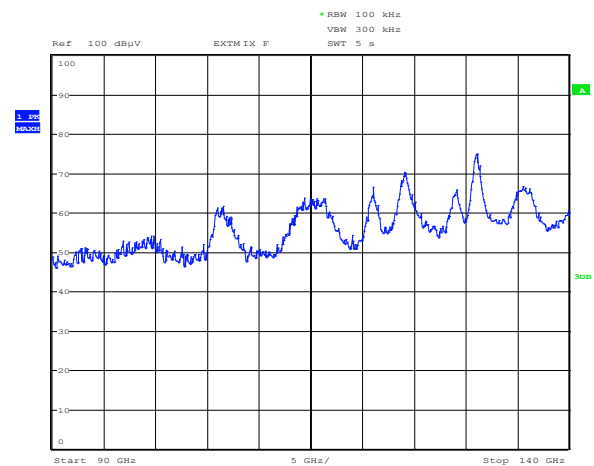

Date: 9.AUG.2017 11:58:28

Figure 8.3-30: Spurious emissions within 90–140 GHz for SN6250T-F-1-L-G-AC, high channel

Note: RBW was reduced to 100 kHz in order to increase dynamic range and verify that there are no spurious emissions underneath the noise floor.

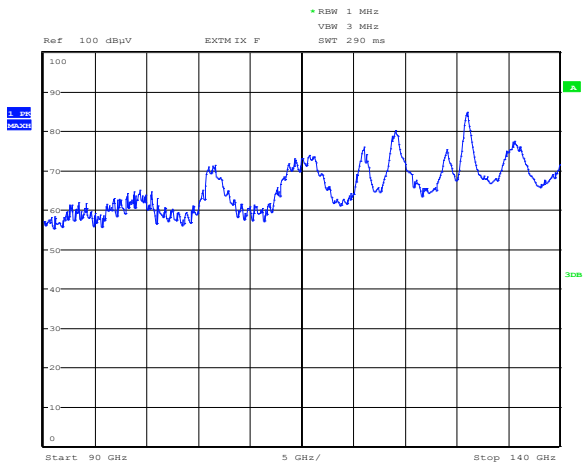

Date: 9.AUG.2017 11:57:53

Figure 8.3-31: Spurious emissions within 90–140 GHz for SN6250T-F-1-L-G-AC, high channel, 1 MHz RBW

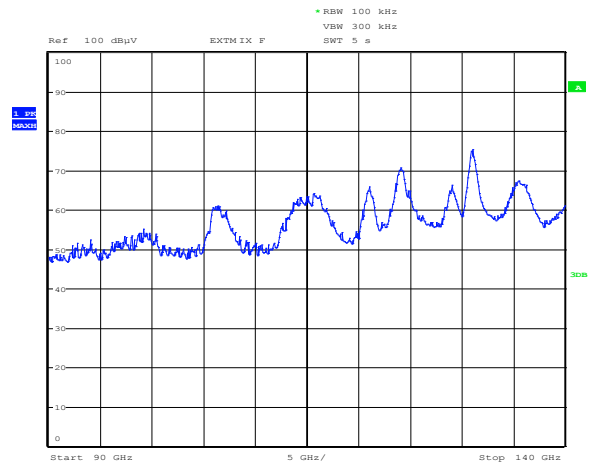

Date: 9.AUG.2017 12:08:30

Figure 8.3-32: Spurious emissions within 90–140 GHz for SN6250T-F-1-L-G-AC, Tx off

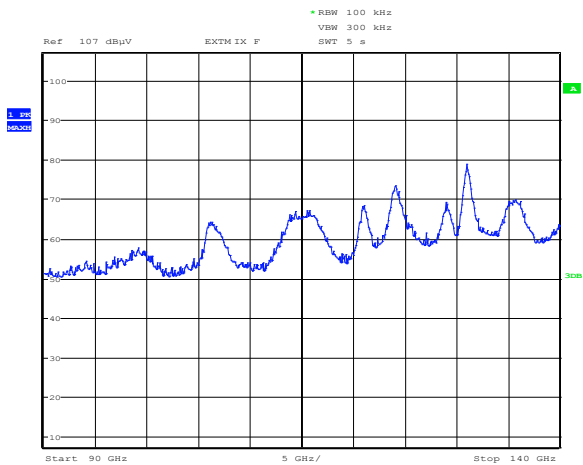

Date: 8.AUG.2017 16:38:14

Figure 8.3-33: Spurious emissions within 90–140 GHz for SN6250T-F-1-H-G-DC, low channel

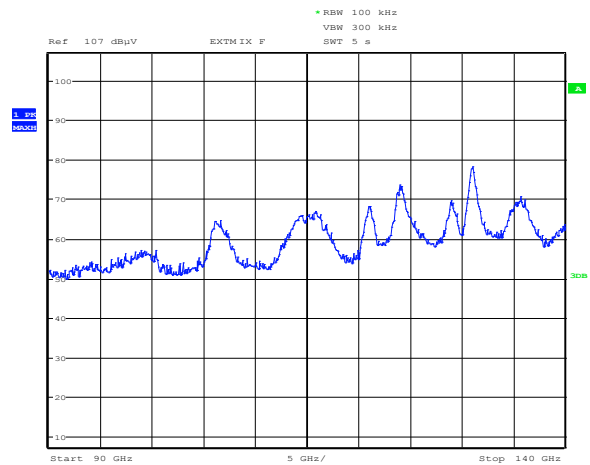

Date: 8.AUG.2017 16:36:47

Figure 8.3-34: Spurious emissions within 90–140 GHz for SN6250T-F-1-H-G-DC, high channel

Note: RBW was reduced to 100 kHz in order to increase dynamic range and verify that there are no spurious emissions underneath the noise floor.

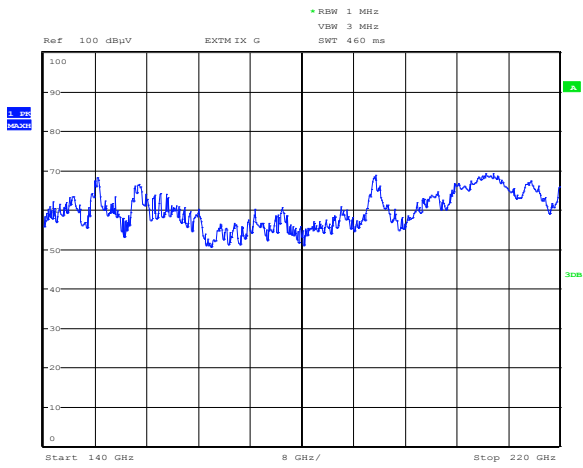

Date: 9.AUG.2017 12:12:04

Figure 8.3-35: Spurious emissions within 140–220 GHz for STN6250T F-1-L-C-AC

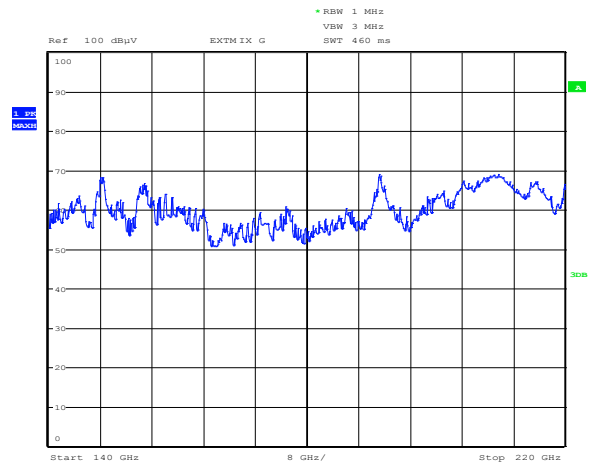

Date: 9.AUG.2017 12:12:44

Figure 8.3-36: Spurious emissions within 140–220 GHz for SN6250T-F-1-L-G-AC

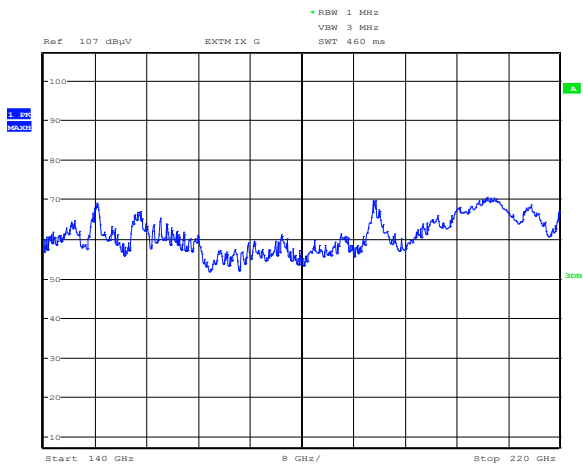

Date: 8.AUG.2017 16:39:50

Figure 8.3-37: Spurious emissions within 140–220 GHz for STN6250T F-1-H-C-DC

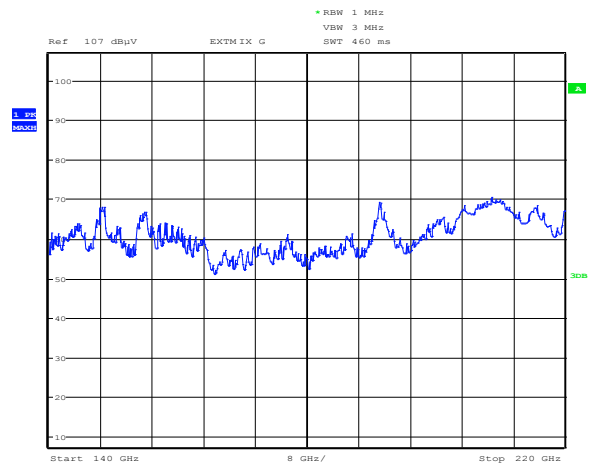

Date: 8.AUG.2017 16:40:28

Figure 8.3-38: Spurious emissions within 90–140 GHz for SN6250T-F-1-H-G-DC

8.4 FCC 15.255(d)(1) 6 dB bandwidth

8.4.1 Definitions and limits

(d)(1) Transmitters with an emission bandwidth of less than 100 MHz must limit their peak transmitter conducted output power to the product of 500 mW times their emission bandwidth divided by 100 MHz. For the purposes of this paragraph, emission bandwidth is defined as the instantaneous frequency range occupied by a steady state radiated signal with modulation, outside which the radiated power spectral density never exceeds 6 dB below the maximum radiated power spectral density in the band, as measured with a 100 kHz resolution bandwidth spectrum analyzer. The center frequency must be stationary during the measurement interval, even if not stationary during normal operation (e.g., for frequency hopping devices).

8.4.2 Test summary

Test date	August 9, 2017	Temperature	22 °C
Test engineer	Andrey Adelberg	Air pressure	1008 mbar
Verdict	Pass	Relative humidity	31 %

8.4.3 Observations, settings and special notes

Spectrum analyser settings:

Resolution bandwidth	100 kHz
Video bandwidth	≥ 3 × RBW
Frequency span	Wider than emission bandwidth
Detector mode	Peak

8.4.4 Test data

Table 8.4-1: 6 dB bandwidth measurement results

Radio	Minimum 6 dB bandwidth, MHz	High power minimum limit, MHz	Margin, MHz
SN6250T-F-1-L-G-AC	208.333	100.000	108.333
SN6250T-F-1-H-G-DC	230.769	100.000	130.769

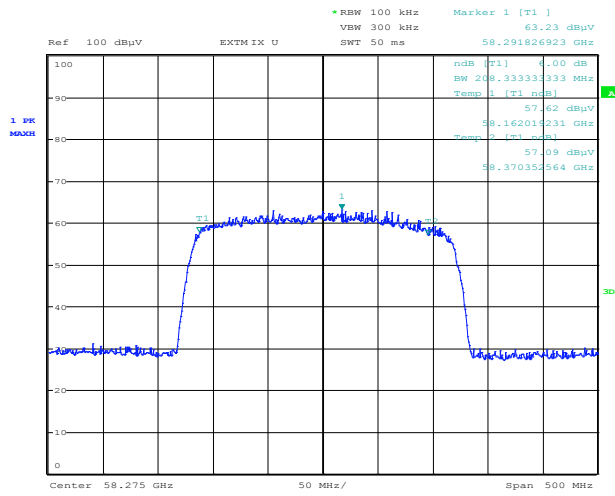

Date: 9.AUG.2017 12:24:16

Figure 8.4-1: 6 dB band width sample plot

8.5 FCC 15.255(e) Frequency stability

8.5.1 Definitions and limits

Fundamental emissions must be contained within the frequency bands specified in this section during all conditions of operation. Equipment is presumed to operate over the temperature range -20 to + 50 degrees Celsius with an input voltage variation of 85% to 115% of rated input voltage, unless justification is presented to demonstrate otherwise.

8.5.2 Test summary

Test date	August 17, 2017	Temperature	22 °C
Test engineer	Andrey Adelberg	Air pressure	1008 mbar
Verdict	Pass	Relative humidity	31 %

8.5.3 Observations, settings and special notes

Low radio:

Lower channel band edge was calculated as follows: 57.275 GHz – half of declared (250 MHz) channel bandwidth.
 Upper channel band edge was calculated as follows: 58.275 GHz + half of declared (250 MHz) channel bandwidth.

High radio:

Lower channel band edge was calculated as follows: 60.775 GHz – half of declared (250 MHz) channel bandwidth.
 Upper channel band edge was calculated as follows: 61.775 GHz + half of declared (250 MHz) channel bandwidth.

8.5.4 Test data

Table 8.5-1: Frequency drift measurement for Low radio

Test conditions	Frequency, GHz	Drift, kHz
+50 °C, 120 V _{AC}	57.275035492	35.492
+40 °C, 120 V _{AC}	57.274907585	-92.415
+30 °C, 120 V _{AC}	57.275136989	136.989
+20 °C, +15 % (132 V _{AC})	57.274791735	-208.265
+20 °C, 120 V _{AC}	57.274918178	-81.822
+20 °C, -15 % (108 V _{AC})	57.274910128	-89.872
+10 °C, 120 V _{AC}	57.274938248	-61.752
0 °C, 120 V _{AC}	57.274908235	-91.765
-10 °C, 120 V _{AC}	57.274887885	-112.115
-20 °C, 120 V _{AC}	57.274932450	-67.550

Note: the drift was calculated as follows: Measured frequency – Declared frequency (57.275 GHz)

Table 8.5-2: Lower band edge drift calculation for Low radio

Lower channel band edge, GHz	Max negative drift, kHz	Drifted lower channel band edge, GHz	Lower band edge limit, GHz	Margin, GHz
57.1500	208.2650	57.14979174	57.0000	0.14979174

Notes: Drifted lower channel band edge = Lower channel band edge – max negative drift.

Table 8.5-3: Upper band edge drift calculation for Low radio

Upper channel band edge, GHz	Max positive drift, kHz	Drifted upper channel band edge, GHz	Upper band edge limit, GHz	Margin, GHz
58.4000	136.9890	58.40013699	64.0000	5.599863011

Notes: Drifted upper channel band edge = Upper channel band edge + max positive drift.

Table 8.5-4: Frequency drift measurement for High radio

Test conditions	Frequency, GHz	Drift, kHz
+50 °C, 48 V _{DC}	61.774842012	-157.988
+40 °C, 48 V _{DC}	61.775049945	49.945
+30 °C, 48 V _{DC}	61.774814243	-185.757
+20 °C, +15 % (55.2 V _{AC})	61.774787255	-212.745
+20 °C, 48 V _{DC}	61.775005736	5.736
+20 °C, -15 % (40.8 V _{AC})	61.774811811	-188.189
+10 °C, 48 V _{DC}	61.774873728	-126.272
0 °C, 48 V _{DC}	61.774952099	-47.901
-10 °C, 48 V _{DC}	61.774792103	-207.897
-20 °C, 48 V _{DC}	61.774816863	-183.137

Note: the drift was calculated as follows: Measured frequency – Declared frequency (61.775 GHz)

Table 8.5-5: Lower band edge drift calculation for High radio

Lower channel band edge, GHz	Max negative drift, kHz	Drifted lower channel band edge, GHz	Lower band edge limit, GHz	Margin, GHz
60.6500	-212.7450	60.65021275	57.0000	3.650212745

Notes: Drifted lower channel band edge = Lower channel band edge – max negative drift.

Table 8.5-6: Upper band edge drift calculation for High radio

Upper channel band edge, GHz	Max positive drift, kHz	Drifted upper channel band edge, GHz	Upper band edge limit, GHz	Margin, GHz
61.9000	49.9450	61.90004995	64.0000	2.099950055

Notes: Drifted upper channel band edge = Upper channel band edge + max positive drift.

Section 9. Block diagrams of test set-ups

9.1 Radiated emissions set-up for frequencies below 1 GHz

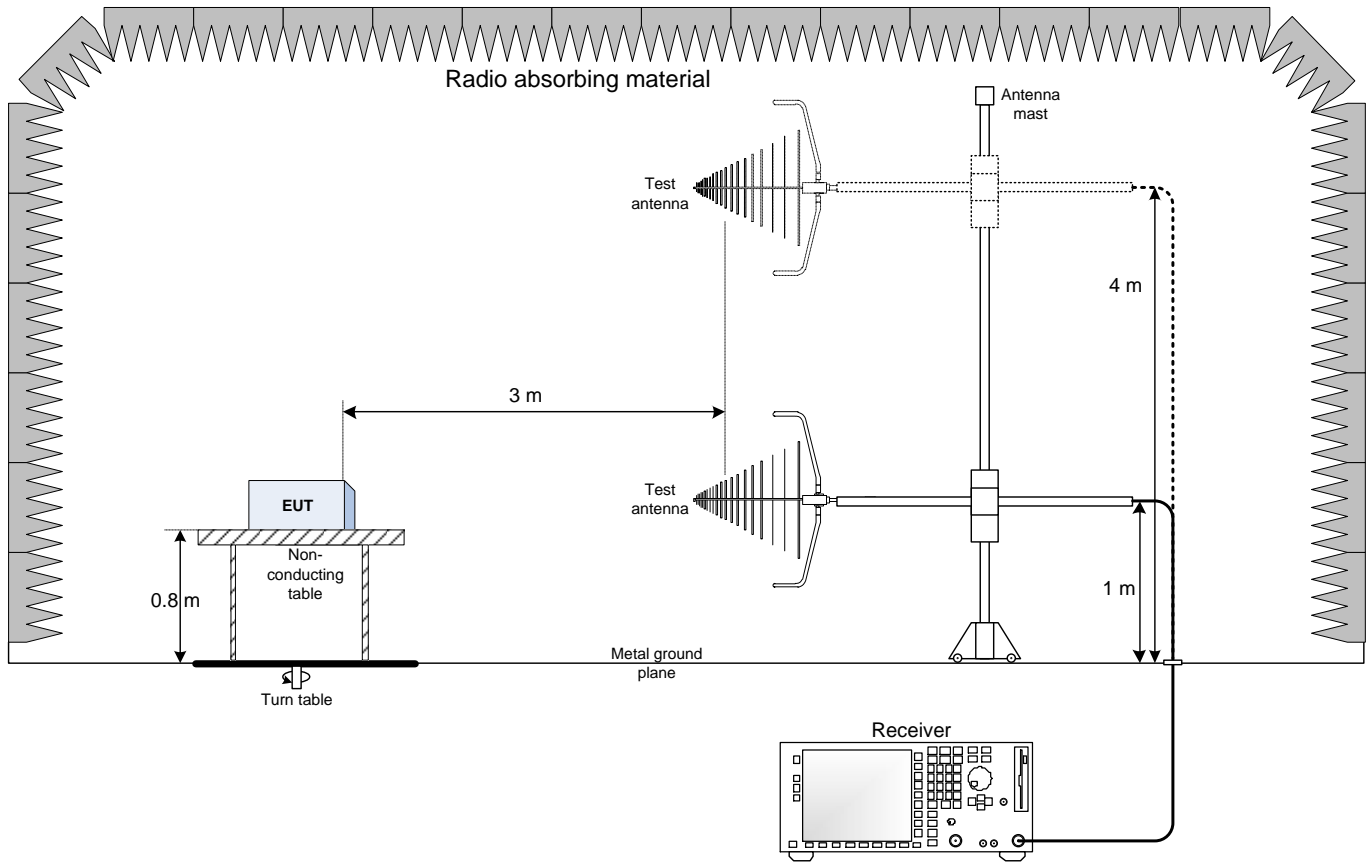

9.2 Radiated emissions set-up for frequencies above 1 GHz

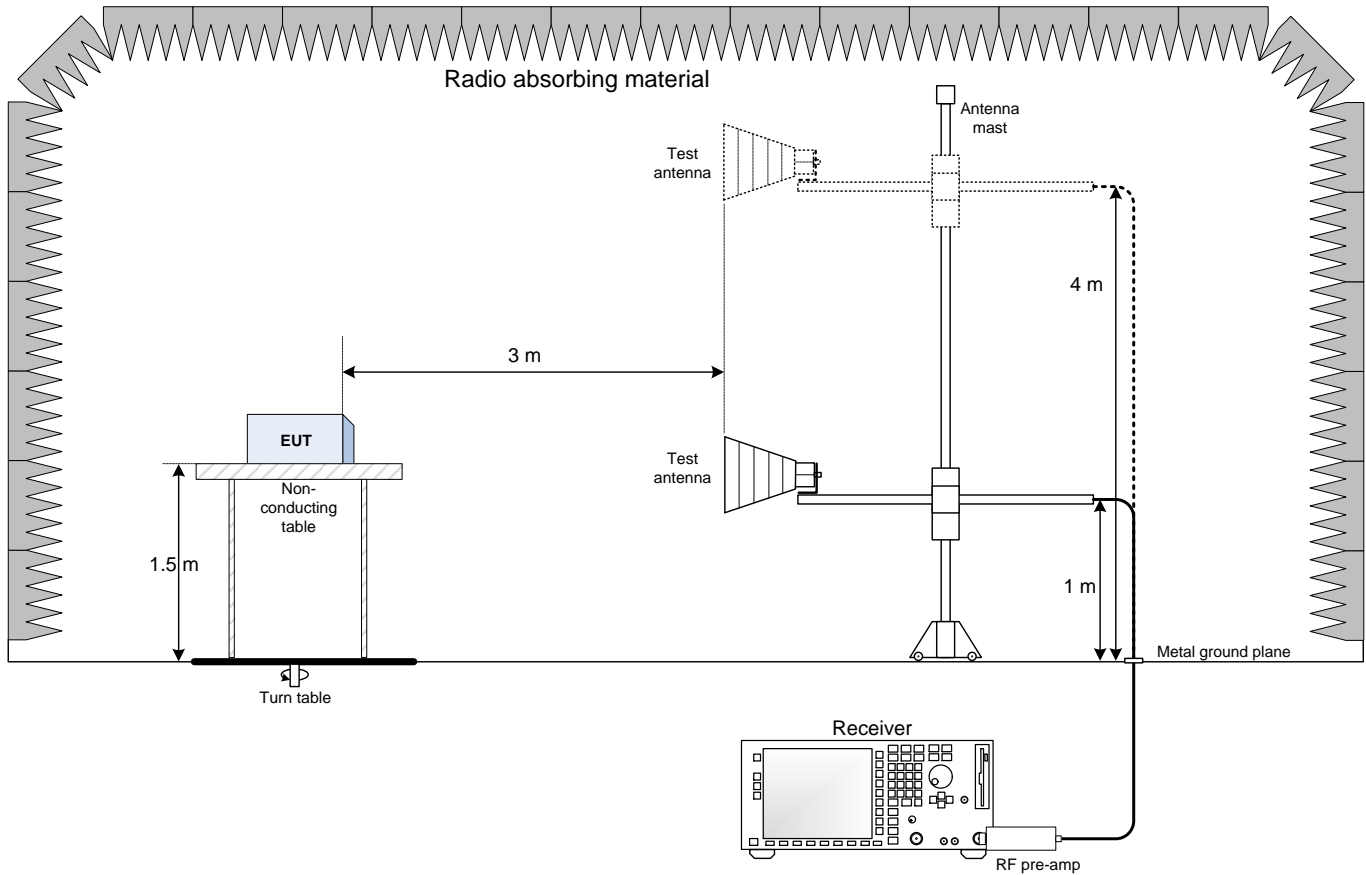

9.3 Conducted emissions set-up

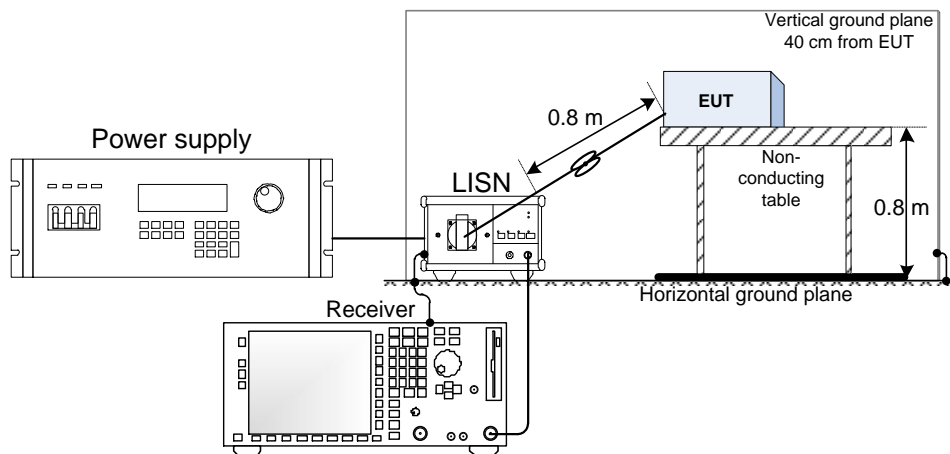

9.4 Conducted power measurement set-up

