

FCC CFR47 PART 22H, 24E, 27, CERTIFICATION TEST REPORT

FCC ID: 2AHZ5KK9

Product: Smartphone

Trade Mark: CUBOT

Model No.: KINGKONG 9

Family Model: N/A

Report No.: S23041403206006

Issue Date: May 11, 2023

Prepared for

Shenzhen Huafurui Technology Co., Ltd

Unit 1401 14/F, Jin qi zhi gu mansion Liu xian street ,Xili, Nan shan district,Shenzhen, China

Prepared by

Shenzhen NTEK Testing Technology Co., Ltd.

1/F, Building E, Fenda Science Park, Sanwei Community,
Xixiang Street Bao'an District, Shenzhen 518126 P.R. China

Tel. 400-800-6106, 0755-2320 0050, 0755-2320 0090

Website: <http://www.ntek.org.cn>

TABLE OF CONTENTS

1. GENERAL INFORMATION.....	5
1. GENERAL INFORMATION.....	5
1.1 PRODUCT DESCRIPTION	5
1.2 RELATED SUBMITTAL(S) / GRANT (S)	7
1.3 TEST METHODOLOGY.....	7
1.4 TEST FACILITY.....	7
MEASUREMENT UNCERTAINTY	7
1.5 SPECIAL ACCESSORIES.....	7
1.6 WORST-CASE CONFIGURATION AND MODE.....	7
2. SYSTEM TEST CONFIGURATION	8
2.1 EUT CONFIGURATION.....	8
2.2 EUT EXERCISE	8
2.3 CONFIGURATION OF EUT SYSTEM.....	8
2.4 TEST SETUP	9
3.TEST AND MEASUREMENT EQUIPMENT	10
4. OUTPUT POWER.....	12
4.1 OUTPUT POWER MEASUREMENT.....	12
6. BANDEDGE AND EMISSION MASK.....	15
7. OUT OF BAND EMISSIONS	17
7.1 MEASUREMENT METHOD	17
8. RADIATED MEASUREMENT	18
8.1. RADIATED POWER (ERP & EIRP).....	18
8.2 LTE BAND 2.....	19

8.3 LTE BAND 4.....	23
8.4 LTE BAND 5.....	27
8.5 LTE BAND 7.....	29
8.6 LTE BAND 12	31
8.7 LTE BAND 17	33
8.8 LTE BAND 66	35
9. SPURIOUS RADIATION EMISSION	39
9.1 LTE BAND 2.....	41
9.2 LTE BAND 4.....	43
9.3 LTE BAND 5.....	45
9.4 LTE BAND 7.....	47
9.5 LTE BAND 12	49
9.6 LTE BAND 17	51
9.7 LTE BAND 66	53
10. FREQUENCY STABILITY	55
10.1 LTE BAND 2	56
10.2 LTE BAND 4	58
10.3 LTE BAND 5	60
10.4 LTE BAND 7	62
10.5 LTE BAND 12	64
10.6 LTE BAND 17	66
10.7 LTE BAND 66	68
11. PEAK-TO-AVERAGE RATIO.....	70
11.1 Description of the PAR Measurement.....	70
11.2 Measuring Instruments.....	70
11.3 Test Procedures.....	70
11.4 Test Setup.....	71

1. GENERAL INFORMATION

1.1 PRODUCT DESCRIPTION

A major technical description of EUT is described as following:

Product Designation:	Smartphone
Trade Mark	CUBOT
Model Name	KINGKONG 9
Family Model	N/A
Model Difference	N/A
FCC ID:	2AHZ5KK9
Frequency Bands:	U.S. Bands: <input checked="" type="checkbox"/> LTE FDD Band 2,4,5,7,12, 17, 66
Frequency Range:	LTE FDD Band 2 Uplink: 1850MHz-1910MHz, Downlink: 1930MHz-1990MHz; LTE FDD Band 4 Uplink: 1710MHz-1755MHz, Downlink: 2110MHz-2155MHz; LTE FDD Band 5 Uplink: 824MHz-849MHz, Downlink: 869MHz-894MHz; LTE-FDD Band 7 Uplink: 2500MHz-2570MHz, Downlink: 2620MHz-2690MHz; LTE FDD Band 12 Uplink: 699MHz-716MHz, Downlink: 729MHz-746MHz; LTE FDD Band 17 Uplink: 704MHz-716MHz, Downlink: 734MHz-746MHz; LTE FDD Band 66 Uplink: 1710MHz-1780MHz, Downlink: 2110MHz-2200MHz;
Type of Modulation:	QPSK/16QAM/64QAM(Only Downlink)
Power Class	Class 3
SIM CARD	SIM 1 and SIM 2 is a chipset unit and tested as a single chipset. The SIM 1 is chosen for test.
Antenna:	PIFA Antenna
Antenna gain:	Band 2:0.67dBi; Band 4:0.58dBi; Band 5:-0.27dBi; Band 7:0.88dBi; Band 12:-0.57dBi; Band 17:-0.57dBi; Band 66:0.58dBi;
Adapter	Model: HJ-PD33W-US Input: 100-240V~50/60Hz 0.8A Output: 5.0V---3.0A 15.0W OR 9.0V---3.0A 27.0W OR 12.0V---2.75A 33.0W MAX
Battery	DC 3.87V, 10600mAh
Power supply	DC 3.87V from battery or DC 5V from Adapter.
Extreme Vol. Limits:	DC 3.4V to DC 4.2V (Nominal DC 3.87V) (Note 1)
HW Version	M129-MUB-V2

SW Version	CUBOT_KINGKONG_9_V06
** Note1: The High Voltage DC 4.2V and Low Voltage 3.4V was declared by manufacturer, The EUT couldn't be operate normally with higher or lower voltage.	

1.2 RELATED SUBMITTAL(S) / GRANT (S)

This submittal(s) (test report) is intended for **FCC ID: 2AHZ5KK9** filing to comply with the FCC Part 22H&24E&27.

1.3 TEST METHODOLOGY

The tests documented in this report were performed in accordance with ANSI/TIA-603-E-2016, FCC CFR 47 Part 2, Part 22, Part 24, Part 27, ,ANSI C63.26:2015.

1.4 TEST FACILITY

The test site used to collect the radiated data is located at:

ShenZhen NTEK Testing Technology Co., Ltd.

1/F, Building E, Fenda Science Park, Sanwei Community, Xixiang Street, Bao'an District, Shenzhen 518126 P.R.China.

The test site is constructed and calibrated to meet the FCC requirements in documents ANSI C63.26:2015& ANSI C63.4: 2014.

FCC Registration No.:463705

IC Registration No.:9270A-1,

CNAS Registration No.:L5516

MEASUREMENT UNCERTAINTY

The reported uncertainty of measurement, where expended uncertainty U is based on a standard uncertainty multiplied by a coverage factor of k=2, providing a level of confidence of approximately 95 %.

No.	Item	Uncertainty
1	Measuring Uncertainty for a Level of Confidence of 95% ($U = 2Uc(y)$)	2.5dB

1.5 SPECIAL ACCESSORIES

The battery and the charger, earphone supplied by the applicant were used as accessories and being tested with EUT intended for FCC grant together.

1.6 WORST-CASE CONFIGURATION AND MODE

The worst-case scenario for all measurements is based on the investigation results.

The device has LTE Bands of: Band 2/4/5/7/12/17/66

The RB Size was selected to measure for peak or average ERP and EIRP, which was based on the conducted power verification baseline data.

For the fundamental investigation of radiated emissions, the EUT is investigated for vertical and horizontal antenna orientations and X Y and Z orientations of the EUT alone. After the investigations the worst case was determined to be at X orientation for all LTE bands.

2. SYSTEM TEST CONFIGURATION

2.1 EUT CONFIGURATION

The EUT configuration for testing is installed on RF field strength measurement to meet the Commission's requirement and operating in a manner which intends to maximize its emission characteristics in a continuous normal application.

2.2 EUT EXERCISE

The Transmitter was operated in the maximum output power mode through Communication Tester. The TX frequency was fixed which was for the purpose of the measurements.

2.3 CONFIGURATION OF EUT SYSTEM

Table 2-1 Equipment Used in EUT System

Item	Equipment	Model No.	ID or Specification	Note
1	Smartphone	KINGKONG 9	FCC ID: 2AHZ5KK9	EUT

*Note: All the accessories have been used during the test.
the following "EUT" in setup diagram means EUT system.*

2.4 TEST SETUP

For Radiated Test Cases

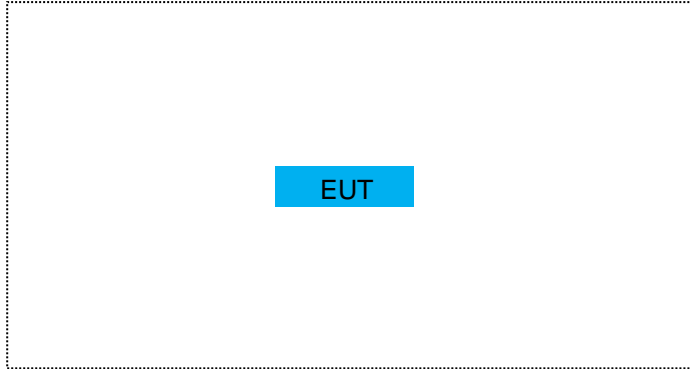

For Conducted Output Power

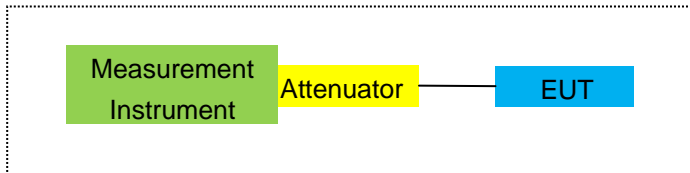

For Peak-to Average Ratio, Occupied Bandwidth, Conducted Band edge and Conducted Spurious Emission

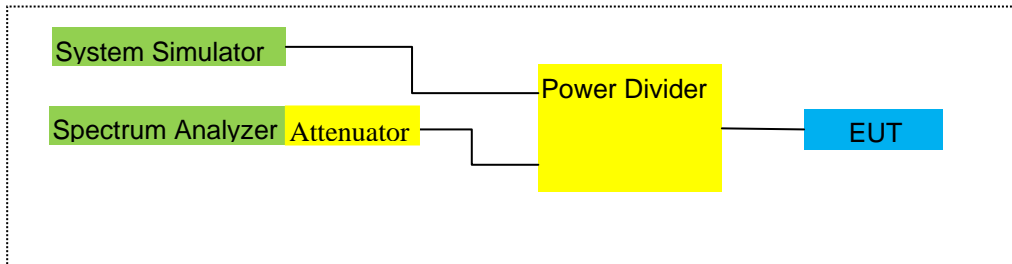

For Frequency Stability

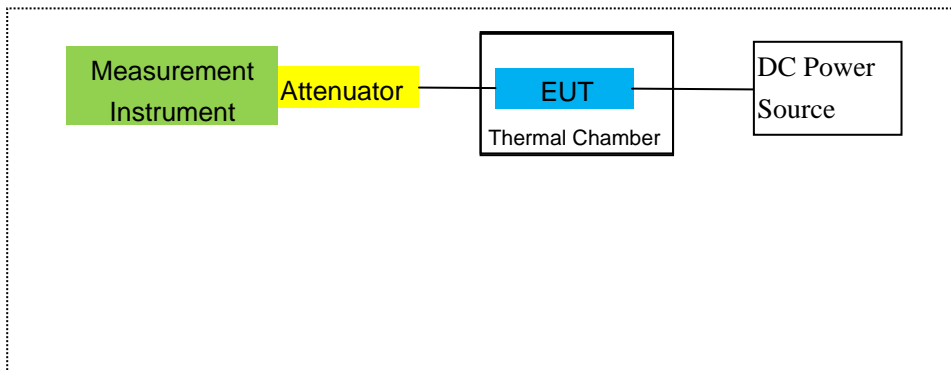

Note: EUT built-in battery-powered, the battery is fully-charged.

3. TEST AND MEASUREMENT EQUIPMENT

The following test and measurement equipment was utilized for the tests documented in this report:

Item	Kind of Equipment	Manufacturer	Type No.	Serial No.	Last calibration	Calibrated until	Calibration period
1	MXA Signal Analyzer	Agilent	N9020A	MY49100060	2022.06.17	2023.06.16	1 year
2	Test Receiver	R&S	ESPI	101318	2023.03.27	2024.03.26	1 year
3	Bilog Antenna	TESEQ	CBL6111D	31216	2023.03.27	2024.03.26	1 year
4	50Ω Coaxial Switch	Anritsu	MP59B	6200983705	2020.05.11	2023.05.10	3 year
5	Horn Antenna	EM	EM-AH-10180	2011071402	2023.03.27	2024.03.26	1 year
6	Horn Ant	Schwarzbeck	BBHA 9170	9170-181	2022.06.17	2023.06.16	1 year
7	Amplifier	EM	EM-30180	060538	2022.06.17	2023.06.16	1 year
8	Loop Antenna	ARA	PLA-1030/B	1029	2023.03.27	2024.03.26	1 year
9	Power Meter	R&S	NRVS	100696	2022.06.17	2023.06.16	1 year
10	Power Sensor	R&S	URV5-Z4	0395.1619.05	2023.03.27	2024.03.26	1 year
11	Test Cable	N/A	R-01	N/A	2022.06.17	2025.06.16	3 year
12	Test Cable	N/A	R-02	N/A	2022.06.17	2025.06.16	3 year
13	Test Cable	N/A	R-03	N/A	2022.06.17	2025.06.16	3 year
14	Test Receiver	R&S	ESCI	101160	2023.03.27	2024.03.26	1 year
15	LISN	R&S	ENV216	101313	2023.03.27	2024.03.26	1 year
16	LISN	EMCO	3816/2	00042990	2023.03.27	2024.03.26	1 year
17	50Ω Coaxial Switch	Anritsu	MP59B	6200264417	2023.03.27	2024.03.26	1 year
18	Passive Voltage Probe	R&S	ESH2-Z3	100196	2023.03.27	2024.03.26	1 year
19	Test Cable	N/A	C01	N/A	2020.05.11	2023.05.10	3 year
20	Test Cable	N/A	C02	N/A	2020.05.11	2023.05.10	3 year
21	Test Cable	N/A	C03	N/A	2020.05.11	2023.05.10	3 year
22	Attenuator	MCE	24-10-34	BN9258	2023.03.27	2024.03.26	1 year
23	Spectrum Analyzer	agilent	e4440a	us44300399	2023.03.27	2024.03.26	1 year
24	test receiver	R&S	ESCI	a0304218	2023.03.27	2024.03.26	1 year
25	Communication Tester	R&S	CMU200	A0304247	2022.06.16	2023.06.15	1 year

26	Thermal Chamber	Ten Billion	TTC-B3C	TBN-960502	2023.03.27	2024.03.26	1 year
27	DC Power Source	N/A	PS-6005D	2017040292 3	2020.05.11	2023.05.10	3 year
28	MXG Vector Signal Generator	Agilent	N5182A	MY47070317	2022.06.16	2023.06.15	1 year
29	Communication Tester	R&S	CMW500	148500	2022.06.16	2023.06.15	1 year

Note: Each piece of equipment is scheduled for calibration once a year except the Test Cable& DC Power Source which is scheduled for calibration every 3 years.

4. OUTPUT POWER

4.1 OUTPUT POWER MEASUREMENT

LTE Measurement Procedure:

All LTE bands conducted power peak and average are obtained from the CMW500 telecommunication test set. The following tests were conducted according to the test requirements outlined in section 6.2 of the 3GPP TS36.101 specification.

UE Power Class: 3 (23 +/- 2dBm). The allowed Maximum Power Reduction (MPR) for the maximum output power due to higher order modulation and transmit bandwidth configuration (resource blocks) is specified in Table 6.2.3-1 of the 3GPP TS36.101.

Table 6.2.3-1: Maximum Power Reduction (MPR) for Power Class 3

Modulation	Channel bandwidth / Transmission bandwidth (RB)						MPR (dB)
	1.4 MHz	3.0 MHz	5 MHz	10 MHz	15 MHz	20 MHz	
QPSK	> 5	> 4	> 8	> 12	> 16	> 18	≤ 1
16 QAM	≤ 5	≤ 4	≤ 8	≤ 12	≤ 16	≤ 18	≤ 1
16 QAM	> 5	> 4	> 8	> 12	> 16	> 18	≤ 2

The allowed A-MPR values specified below in Table 6.2.4.-1 of 3GPP TS36.101 are in addition to the allowed MPR requirements. All the measurements below were performed with A-MPR disabled, by using Network Signaling Value of "NS_01".3

Table 6.2.4-1: Additional Maximum Power Reduction (A-MPR)

Network Signalling value	Requirements (sub-clause)	E-UTRA Band	Channel bandwidth (MHz)	Resources Blocks (N_{RB})	A-MPR (dB)
NS_01	6.6.2.1.1	Table 5.5-1	1.4, 3, 5, 10, 15, 20	Table 5.6-1	NA
NS_03	6.6.2.2.1	2, 4, 10, 23, 25, 35, 36	3	>5	≤ 1
			5	>6	≤ 1
			10	>6	≤ 1
			15	>8	≤ 1
			20	>10	≤ 1
NS_04	6.6.2.2.2	41	5	>6	≤ 1
			10, 15, 20	See Table 6.2.4-4	
NS_05	6.6.3.3.1	1	10, 15, 20	≥ 50	≤ 1
NS_06	6.6.2.2.3	12, 13, 14, 17	1.4, 3, 5, 10	Table 5.6-1	n/a
NS_07	6.6.2.2.3	13	10	Table 6.2.4-2	Table 6.2.4-2
	6.6.3.3.2				
NS_08	6.6.3.3.3	19	10, 15	> 44	≤ 3
NS_09	6.6.3.3.4	21	10, 15	> 40	≤ 1
				> 55	≤ 2
NS_10		20	15, 20	Table 6.2.4-3	Table 6.2.4-3
NS_11	6.6.2.2.1	23 ¹	1.4, 3, 5, 10	Table 6.2.4-5	Table 6.2.4-5
..					
NS_32	-	-	-	-	-

Note 1: Applies to the lower block of Band 23, i.e. a carrier placed in the 2000-2010 MHz region.

Test data reference attachment.

5. OCCUPIED BANDWIDTH

RULE PART(S)

FCC: §2.1049

LIMITS

For reporting purposes only

TEST PROCEDURE

The transmitter output was connected to a calibrated coaxial cable and coupler, the other end of which was connected to a spectrum analyzer. The occupied bandwidth was measured with the spectrum analyzer at the low, middle and high channel in each band. The -26dB bandwidth was also measured and recorded.

MODES TESTED

Band 2/4/5/7/12/17/66

RESULTS

PASS

Test data reference attachment.

6. BANDEDGE AND EMISSION MASK

RULE PART(S)

FCC: §2.1051, §22.901, §22.917, §24.238, §27.53,
FCC: §22.359

LIMITS

FCC: §22.917, §24.238, §27.53

The power of any emission outside of the authorized operating frequency ranges must be attenuated below the transmitting power (P) by a factor of at least $43 + 10 \log (P)$ dB.

(m)(4) For mobile digital stations, the attenuation factor shall be not less than $40 + 10 \log (P)$ dB on all frequencies between the channel edge and 5 megahertz from the channel edge, $43 + 10 \log (P)$ dB on all frequencies between 5 megahertz and X megahertz from the channel edge, and $55 + 10 \log (P)$ dB on all frequencies more than X megahertz from the channel edge, where X is the greater of 6 megahertz or the actual emission bandwidth as defined in paragraph (m)(6) of this section. In addition, the attenuation factor shall not be less that $43 + 10 \log (P)$ dB on all frequencies between 2490.5 MHz and 2496 MHz and $55 + 10 \log (P)$ dB at or below 2490.5 MHz. Mobile Satellite Service licensees operating on frequencies below 2495 MHz may also submit a documented interference complaint against BRS licensees operating on channel BRS Channel 1 on the same terms and conditions as adjacent channel BRS or EBS licensees. Show citation box.

(c)(4) On all frequencies between 763-775 MHz and 793-805 MHz, by a factor not less than $65 + 10 \log (P)$ dB in a 6.25 kHz band segment, for mobile and portable stations;

TEST PROCEDURE

The transmitter output was connected to a CMW500 Test Set and configured to operate at maximum power. The band edge emissions were measured at the required operating frequencies in each band on the Spectrum Analyzer.

For each band edge measurement:

Set the spectrum analyzer span to include the block edge frequency

Set a marker to point the corresponding band edge frequency in each test case.

Set resolution bandwidth to at least 1% of emission bandwidth.

MODES TESTED

Band 2/4/5/7/12/17/66

RESULTS

Test data reference attachment.

7. OUT OF BAND EMISSIONS

RULE PART(S)

FCC: §2.1051, §22.901, §22.917, §24.238, §27.53

LIMITS

1. The power of any emission outside of the authorized operating frequency ranges must be attenuated below the transmitting power (P) by a factor of at least $43 + 10 \log (P)$ dB.
2. The Band 7/41 emission outside of the authorized operating frequency ranges must be attenuated below the transmitting power (P) by a factor of at least $55 + 10 \log (P)$ dB.

TEST PROCEDURE

The RF output of the transmitter was connected to a spectrum analyzer through a calibrated coaxial cable. Sufficient scans were taken to show the out-of-band Emissions, if any, up to 10th harmonic. Multiple sweeps were recorded in maximum hold mode using a peak detector to ensure that the worst-case emissions were caught.

For each out of band emissions measurement:

-
- Set RBW & VBW to 100 kHz for the measurement below 1 GHz, and 1 MHz for the measurement above 1 GHz.

MODES TESTED

- Band 2/4/5/7/12/17/66
-

7.1 MEASUREMENT METHOD

The test set up and general procedure is similar to conducted peak output power test. Only different for setting the measurement configuration of the measuring instrument of Spectrum Analyzer.

Test data reference attachment.

8. RADIATED MEASUREMENT

8.1. RADIATED POWER (ERP & EIRP)

RULE PART(S)

FCC: §2.1046, §22.913, §24.232, §27.50

LIMITS:

22.913(a) - The ERP of mobile transmitters and auxiliary test transmitters must not exceed 7 Watts.
27.50 (c) (10) the following power and antenna height requirements apply to stations transmitting in the 698–746 MHz band, the portable stations (hand-held devices) are limited to 3 watts ERP.
27.50 (b)(10) Portable stations (hand-held devices) transmitting in the 746–757 MHz, 758–763 MHz, 776–793 MHz, and 805–806 MHz bands are limited to 3 watts ERP.
27.50 (d)(4) The following power and antenna height requirements apply to stations transmitting in the 1710–1755 MHz and 2110–2155 MHz bands: Fixed, mobile, and portable (hand-held) stations operating in the 1710–1755 MHz band are limited to 1 watt EIRP.
27.50 (h)(2) Mobile and other user stations. Mobile stations are limited to 2.0 watts EIRP. All user stations are limited to 2.0 watts transmitter output power.

TEST PROCEDURE

ANSI/TIA-603-E Clause 2.2.17

KDB 971168 v02r01 RF power output using broadband peak and average power meter method.

KDB 971168 D01 Power Meas License Digital Systems v02r01, "Measurement Guidance for Certification of Licensed Digital Transmitters"

MODES TESTED

Band 2/4/5/7/12/17/66

RESULTS

Pass

8.2 LTE BAND 2

Radiated Power (EIRP) for Band 2										
Mode	RB/RB SIZE	Frequency	Result					Polarization Of	Max. ERP	Conclusion
			SG Level (dBm)	Cable Loss (dBm)	Antenna Factor (dB)	Max. EIRP Average (dBm)	Max. EIRP Average (mW)			
1.4MHz Band QPSK	1/#Mid	1850.7	-2.42	3.76	28.24	22.06	160.694	Horizontal	Pass	
		1880	-2.23	3.91	28.22	22.08	161.436	Horizontal	Pass	
		1909.3	-2.14	3.93	28.20	22.13	163.305	Horizontal	Pass	
3.0MHz Band QPSK	1/#Mid	1851.5	-2.48	3.77	28.23	21.98	157.761	Horizontal	Pass	
		1880	-2.33	3.91	28.24	22.00	158.489	Horizontal	Pass	
		1908.5	-2.20	3.94	28.25	22.11	162.555	Horizontal	Pass	
5.0MHz Band QPSK	1/#Mid	1852.5	-2.37	3.77	28.31	22.17	164.816	Horizontal	Pass	
		1880	-1.99	3.91	28.22	22.32	170.608	Horizontal	Pass	
		1907.5	-1.92	3.94	28.20	22.34	171.396	Horizontal	Pass	
10.0MHz Band QPSK	1/#Mid	1855	-2.23	3.79	28.33	22.31	170.216	Horizontal	Pass	
		1880	-1.93	3.95	28.22	22.34	171.396	Horizontal	Pass	
		1905	-1.82	3.97	28.19	22.40	173.780	Horizontal	Pass	
15.0MHz Band QPSK	1/#Mid	1857.5	-2.19	3.79	28.34	22.36	172.187	Horizontal	Pass	
		1880	-1.98	3.95	28.22	22.29	169.434	Horizontal	Pass	
		1902.5	-1.84	3.97	28.18	22.37	172.584	Horizontal	Pass	
20.0MHz Band QPSK	1/#Mid	1860	-2.18	3.81	28.35	22.36	172.187	Horizontal	Pass	
		1880	-1.85	3.96	28.22	22.41	174.181	Horizontal	Pass	
		1900	-1.79	4.00	28.16	22.37	172.584	Horizontal	Pass	
1.4MHz Band QPSK	1/#Mid	1850.7	-3.02	3.76	28.24	21.46	139.959	Vertical	Pass	
		1880	-3.22	3.91	28.22	21.09	128.529	Vertical	Pass	
		1909.3	-2.56	3.93	28.20	21.71	148.252	Vertical	Pass	
3.0MHz Band QPSK	1/#Mid	1851.5	-3.45	3.77	28.23	21.01	126.183	Vertical	Pass	
		1880	-3.46	3.91	28.24	20.87	122.180	Vertical	Pass	
		1908.5	-2.78	3.94	28.25	21.53	142.233	Vertical	Pass	
5.0MHz Band QPSK	1/#Mid	1852.5	-3.19	3.77	28.31	21.35	136.458	Vertical	Pass	
		1880	-2.57	3.91	28.22	21.74	149.279	Vertical	Pass	
		1907.5	-3.02	3.94	28.20	21.24	133.045	Vertical	Pass	
10.0MHz Band QPSK	1/#Mid	1855	-2.92	3.79	28.33	21.62	145.211	Vertical	Pass	
		1880	-3.01	3.95	28.22	21.26	133.660	Vertical	Pass	
		1905	-3.33	3.97	28.19	20.89	122.744	Vertical	Pass	
15.0MHz	1/#Mid	1857.5	-3.15	3.79	28.34	21.40	138.038	Vertical	Pass	

Band QPSK		1880	-2.93	3.95	28.22	21.34	136.144	Vertical	Pass
		1902.5	-3.27	3.97	28.18	20.94	124.165	Vertical	Pass
20.0MHz Band QPSK	1/#Mid	1860	-2.86	3.81	28.35	21.68	147.231	Vertical	Pass
		1880	-3.13	3.96	28.22	21.13	129.718	Vertical	Pass
		1900	-2.87	4.00	28.16	21.29	134.586	Vertical	Pass

Radiated Power (EIRP) for Band 2										
Mode	RB/RB SIZE	Frequency	Result						Conclusion	
			SG Level (dBm)	Cable Loss (dBm)	Antenna Factor (dB)	Max. EIRP	Max. EIRP	Polarization Of Max. ERP		
						Average (dBm)	Average			Average
							(mW)			
1.4MHz Band 16 QAM	1/#Mid	1850.7	-3.54	3.76	28.24	20.94	124.165	Horizontal	Pass	
		1880	-3.01	3.91	28.22	21.30	134.896	Horizontal	Pass	
		1909.3	-2.94	3.93	28.20	21.33	135.831	Horizontal	Pass	
3.0MHz Band 16 QAM	1/#Mid	1851.5	-3.04	3.77	28.23	21.42	138.676	Horizontal	Pass	
		1880	-3.12	3.91	28.24	21.21	132.130	Horizontal	Pass	
		1908.5	-3.33	3.94	28.25	20.98	125.314	Horizontal	Pass	
5.0MHz Band 16 QAM	1/#Mid	1852.5	-2.98	3.77	28.31	21.56	143.219	Horizontal	Pass	
		1880	-2.89	3.91	28.22	21.42	138.676	Horizontal	Pass	
		1907.5	-2.57	3.94	28.20	21.69	147.571	Horizontal	Pass	
10.0MHz Band 16 QAM	1/#Mid	1855	-3.03	3.79	28.33	21.51	141.579	Horizontal	Pass	
		1880	-3.02	3.95	28.22	21.25	133.352	Horizontal	Pass	
		1905	-2.49	3.97	28.19	21.73	148.936	Horizontal	Pass	
15.0MHz Band 16 QAM	1/#Mid	1857.5	-3.01	3.79	28.34	21.54	142.561	Horizontal	Pass	
		1880	-2.80	3.95	28.22	21.47	140.281	Horizontal	Pass	
		1902.5	-2.76	3.97	28.18	21.45	139.637	Horizontal	Pass	
20.0MHz Band 16 QAM	1/#Mid	1860	-2.90	3.81	28.35	21.64	145.881	Horizontal	Pass	
		1880	-2.60	3.96	28.22	21.66	146.555	Horizontal	Pass	
		1900	-2.42	4.00	28.16	21.74	149.279	Horizontal	Pass	
1.4MHz Band 16 QAM	1/#Mid	1850.7	-4.37	3.76	28.24	20.11	102.565	Vertical	Pass	
		1880	-3.65	3.91	28.22	20.66	116.413	Vertical	Pass	
		1909.3	-4.10	3.93	28.20	20.17	103.992	Vertical	Pass	
3.0MHz Band 16 QAM	1/#Mid	1851.5	-3.69	3.77	28.23	20.77	119.399	Vertical	Pass	
		1880	-4.48	3.91	28.24	19.85	96.605	Vertical	Pass	
		1908.5	-4.23	3.94	28.25	20.08	101.859	Vertical	Pass	
5.0MHz Band 16 QAM	1/#Mid	1852.5	-3.91	3.77	28.31	20.63	115.611	Vertical	Pass	
		1880	-4.01	3.91	28.22	20.30	107.152	Vertical	Pass	
		1907.5	-3.91	3.94	28.20	20.35	108.393	Vertical	Pass	
10.0MHz Band 16 QAM	1/#Mid	1855	-3.80	3.79	28.33	20.74	118.577	Vertical	Pass	
		1880	-3.54	3.95	28.22	20.73	118.304	Vertical	Pass	
		1905	-3.52	3.97	28.19	20.70	117.490	Vertical	Pass	
15.0MHz Band 16	1/#Mid	1857.5	-4.32	3.79	28.34	20.23	105.439	Vertical	Pass	
		1880	-4.10	3.95	28.22	20.17	103.992	Vertical	Pass	

QAM		1902.5	-3.63	3.97	28.18	20.58	114.288	Vertical	Pass
20.0MHz	1/#Mid	1860	-3.78	3.81	28.35	20.76	119.124	Vertical	Pass
Band 16		1880	-3.62	3.96	28.22	20.64	115.878	Vertical	Pass
QAM		1900	-4.14	4.00	28.16	20.02	100.462	Vertical	Pass

Note:

SG Level= Signal generator output

Max. EIRP Average (dBm)= Antenna Gain(dB)+ SG Level (dBm)- Cable Loss(dBm)

Factor Gain(dB)=Antenna Gain(dB) + Amplifier Factor (dB)

8.3 LTE BAND 4

Radiated Power (EIRP) for Band 4										
Mode	RB/RB SIZE	Frequency	Result						Polarization Of Max. ERP	Conclusion
			SG Level	Cable Loss	Antenna Factor	Max. EIRP	Max. EIRP			
			(dBm)	(dBm)	(dB)	Average	Average			
						(dBm)	(mW)			
1.4MHz Band QPSK	1/#Mid	1710.7	-2.33	3.12	27.58	22.13	163.305	Horizontal	Pass	
		1732.5	-2.32	3.27	27.61	22.02	159.221	Horizontal	Pass	
		1754.3	-2.30	3.29	27.63	22.04	159.956	Horizontal	Pass	
3.0MHz Band QPSK	1/#Mid	1711.5	-2.50	3.13	27.61	21.98	157.761	Horizontal	Pass	
		1732.5	-2.42	3.27	27.61	21.92	155.597	Horizontal	Pass	
		1753.5	-2.34	3.30	27.62	21.98	157.761	Horizontal	Pass	
5.0MHz Band QPSK	1/#Mid	1712.5	-2.27	3.13	27.63	22.23	167.109	Horizontal	Pass	
		1732.5	-2.17	3.27	27.61	22.17	164.816	Horizontal	Pass	
		1752.5	-2.05	3.30	27.60	22.25	167.880	Horizontal	Pass	
10.0MHz Band QPSK	1/#Mid	1715	-2.21	3.15	27.64	22.28	169.044	Horizontal	Pass	
		1732.5	-1.98	3.31	27.61	22.32	170.608	Horizontal	Pass	
		1750	-2.00	3.33	27.59	22.26	168.267	Horizontal	Pass	
15.0MHz Band QPSK	1/#Mid	1717.5	-2.22	3.15	27.65	22.28	169.044	Horizontal	Pass	
		1732.5	-2.06	3.31	27.61	22.24	167.494	Horizontal	Pass	
		1747.5	-2.00	3.33	27.57	22.24	167.494	Horizontal	Pass	
20.0MHz Band QPSK	1/#Mid	1720	-2.16	3.17	27.66	22.33	171.002	Horizontal	Pass	
		1732.5	-1.99	3.32	27.61	22.30	169.824	Horizontal	Pass	
		1745	-1.93	3.36	27.56	22.27	168.655	Horizontal	Pass	
1.4MHz Band QPSK	1/#Mid	1710.7	-2.81	3.12	27.58	21.65	146.218	Vertical	Pass	
		1732.5	-2.94	3.27	27.61	21.40	138.038	Vertical	Pass	
		1754.3	-3.33	3.29	27.63	21.01	126.183	Vertical	Pass	
3.0MHz Band QPSK	1/#Mid	1711.5	-3.47	3.13	27.61	21.01	126.183	Vertical	Pass	
		1732.5	-3.42	3.27	27.61	20.92	123.595	Vertical	Pass	
		1753.5	-2.78	3.30	27.62	21.54	142.561	Vertical	Pass	
5.0MHz Band QPSK	1/#Mid	1712.5	-3.40	3.13	27.63	21.10	128.825	Vertical	Pass	
		1732.5	-2.86	3.27	27.61	21.48	140.605	Vertical	Pass	
		1752.5	-2.94	3.30	27.60	21.36	136.773	Vertical	Pass	
10.0MHz Band QPSK	1/#Mid	1715	-3.69	3.15	27.64	20.80	120.226	Vertical	Pass	
		1732.5	-2.58	3.31	27.61	21.72	148.594	Vertical	Pass	
		1750	-3.30	3.33	27.59	20.96	124.738	Vertical	Pass	

15.0MHz		1717.5	-2.90	3.15	27.65	21.60	144.544	Vertical	Pass
Band	1/#Mid	1732.5	-2.71	3.31	27.61	21.59	144.212	Vertical	Pass
QPSK		1747.5	-2.74	3.33	27.57	21.50	141.254	Vertical	Pass
20.0MHz		1720	-3.43	3.17	27.66	21.06	127.644	Vertical	Pass
Band	1/#Mid	1732.5	-3.27	3.32	27.61	21.02	126.474	Vertical	Pass
QPSK		1745	-2.91	3.36	27.56	21.29	134.586	Vertical	Pass

Radiated Power (EIRP) for Band 4									
Mode	RB/RB SIZE	Frequency	Result						Conclusion
			SG Level	Cable Loss	Antenna Factor	Max. EIRP	Max. EIRP	Polarization	
			(dBm)	(dBm)	(dB)	Average	Average	Of Max. ERP	
						(dBm)	(mW)		
1.4MHz Band 16 QAM	1/#Mid	1710.7	-3.14	3.12	27.58	21.32	135.519	Horizontal	Pass
		1732.5	-2.99	3.27	27.61	21.35	136.458	Horizontal	Pass
		1754.3	-2.99	3.29	27.63	21.35	136.458	Horizontal	Pass
3.0MHz Band 16 QAM	1/#Mid	1711.5	-3.08	3.13	27.61	21.40	138.038	Horizontal	Pass
		1732.5	-3.21	3.27	27.61	21.13	129.718	Horizontal	Pass
		1753.5	-3.43	3.30	27.62	20.89	122.744	Horizontal	Pass
5.0MHz Band 16 QAM	1/#Mid	1712.5	-2.91	3.13	27.63	21.59	144.212	Horizontal	Pass
		1732.5	-2.87	3.27	27.61	21.47	140.281	Horizontal	Pass
		1752.5	-2.56	3.30	27.60	21.74	149.279	Horizontal	Pass
10.0MHz Band 16 QAM	1/#Mid	1715	-2.98	3.15	27.64	21.51	141.579	Horizontal	Pass
		1732.5	-3.17	3.31	27.61	21.13	129.718	Horizontal	Pass
		1750	-2.55	3.33	27.59	21.71	148.252	Horizontal	Pass
15.0MHz Band 16 QAM	1/#Mid	1717.5	-2.78	3.15	27.65	21.72	148.594	Horizontal	Pass
		1732.5	-2.84	3.31	27.61	21.46	139.959	Horizontal	Pass
		1747.5	-2.86	3.33	27.57	21.38	137.404	Horizontal	Pass
20.0MHz Band 16 QAM	1/#Mid	1720	-2.73	3.17	27.66	21.76	149.968	Horizontal	Pass
		1732.5	-2.74	3.32	27.61	21.55	142.889	Horizontal	Pass
		1745	-2.55	3.36	27.56	21.65	146.218	Horizontal	Pass
1.4MHz Band 16 QAM	1/#Mid	1710.7	-3.87	3.12	27.58	20.59	114.551	Vertical	Pass
		1732.5	-4.03	3.27	27.61	20.31	107.399	Vertical	Pass
		1754.3	-3.66	3.29	27.63	20.68	116.950	Vertical	Pass
3.0MHz Band 16 QAM	1/#Mid	1711.5	-4.33	3.13	27.61	20.15	103.514	Vertical	Pass
		1732.5	-3.76	3.27	27.61	20.58	114.288	Vertical	Pass
		1753.5	-4.33	3.30	27.62	19.99	99.770	Vertical	Pass
5.0MHz Band 16 QAM	1/#Mid	1712.5	-4.24	3.13	27.63	20.26	106.170	Vertical	Pass
		1732.5	-4.18	3.27	27.61	20.16	103.753	Vertical	Pass
		1752.5	-3.91	3.30	27.60	20.39	109.396	Vertical	Pass
10.0MHz Band 16 QAM	1/#Mid	1715	-4.40	3.15	27.64	20.09	102.094	Vertical	Pass
		1732.5	-3.68	3.31	27.61	20.62	115.345	Vertical	Pass
		1750	-3.55	3.33	27.59	20.71	117.761	Vertical	Pass
15.0MHz Band 16	1/#Mid	1717.5	-4.30	3.15	27.65	20.20	104.713	Vertical	Pass
		1732.5	-3.52	3.31	27.61	20.78	119.674	Vertical	Pass

QAM		1747.5	-3.71	3.33	27.57	20.53	112.980	Vertical	Pass
20.0MHz	1/#Mid	1720	-3.77	3.17	27.66	20.72	118.032	Vertical	Pass
Band 16		1732.5	-3.90	3.32	27.61	20.39	109.396	Vertical	Pass
QAM		1745	-4.14	3.36	27.56	20.06	101.391	Vertical	Pass

Note:

SG Level= Signal generator output

Max. EIRP Average (dBm)= Antenna Gain(dB)+ SG Level (dBm)- Cable Loss(dBm)

Factor Gain(dB)=Antenna Gain(dB) + Amplifier Factor (dB)

8.4 LTE BAND 5

Radiated Power (ERP) for Band 5										
Mode	RB/RB SIZE	Frequency	Result							Conclusion
			SG Level	Cable Loss	Antenna Factor	Correction	Max. EIRP	Max. EIRP	Polarization	
			(dBm)	(dBm)	(dB)	(dB)	Average	Average	Of Max. ERP	
							(dBm)	(mW)		
1.4MHz Band QPSK	3/#Mid	824.7	6.97	2.01	19.68	2.15	22.49	177.419	Horizontal	Pass
		836.5	6.85	2.01	19.77	2.15	22.46	176.198	Horizontal	Pass
		848.3	6.65	2.02	19.82	2.15	22.30	169.824	Horizontal	Pass
3.0MHz Band QPSK	1/#Mid	825.5	6.74	2.01	19.70	2.15	22.28	169.044	Horizontal	Pass
		836.5	6.64	2.01	19.77	2.15	22.25	167.880	Horizontal	Pass
		847.5	6.51	2.02	19.81	2.15	22.15	164.059	Horizontal	Pass
5.0MHz Band QPSK	1/#Mid	826.5	7.02	2.01	19.71	2.15	22.57	180.717	Horizontal	Pass
		836.5	6.90	2.01	19.77	2.15	22.51	178.238	Horizontal	Pass
		846.5	6.74	2.02	19.79	2.15	22.36	172.187	Horizontal	Pass
10.0MHz Band QPSK	1/#Mid	829	7.04	2.01	19.73	2.15	22.61	182.390	Horizontal	Pass
		836.5	6.99	2.01	19.77	2.15	22.60	181.970	Horizontal	Pass
		844	6.89	2.02	19.78	2.15	22.50	177.828	Horizontal	Pass
1.4MHz Band QPSK	1/#Mid	824.7	5.85	2.01	19.68	2.15	21.37	137.088	Vertical	Pass
		836.5	5.78	2.01	19.77	2.15	21.39	137.721	Vertical	Pass
		848.3	5.77	2.02	19.82	2.15	21.42	138.676	Vertical	Pass
3.0MHz Band QPSK	1/#Mid	825.5	5.29	2.01	19.70	2.15	20.83	121.060	Vertical	Pass
		836.5	6.15	2.01	19.77	2.15	21.76	149.968	Vertical	Pass
		847.5	6.12	2.02	19.81	2.15	21.76	149.968	Vertical	Pass
5.0MHz Band QPSK	1/#Mid	826.5	6.11	2.01	19.71	2.15	21.66	146.555	Vertical	Pass
		836.5	5.36	2.01	19.77	2.15	20.97	125.026	Vertical	Pass
		846.5	5.57	2.02	19.79	2.15	21.19	131.522	Vertical	Pass
10.0MHz Band QPSK	1/#Mid	829	5.85	2.01	19.73	2.15	21.42	138.676	Vertical	Pass
		836.5	5.59	2.01	19.77	2.15	21.20	131.826	Vertical	Pass
		844	5.76	2.02	19.78	2.15	21.37	137.088	Vertical	Pass

Radiated Power (ERP) for Band 5											
Mode	RB/RB SIZE	Frequency	Result							Polarization Of Max. ERP	Conclusion
			SG Level	Cable Loss	Antenna Factor	Correction	Max. EIRP	Max. EIRP			
			(dBm)	(dBm)	(dB)	(dB)	Average	Average			
							(dBm)	(mW)			
1.4MHz	3/#Mid	824.7	6.12	2.01	19.68	2.15	21.64	145.881	Horizontal	Pass	
Band 16		836.5	6.05	2.01	19.77	2.15	21.66	146.555	Horizontal	Pass	
QAM		848.3	5.89	2.02	19.82	2.15	21.54	142.561	Horizontal	Pass	
3.0MHz	1/#Mid	825.5	6.20	2.01	19.70	2.15	21.74	149.279	Horizontal	Pass	
Band 16		836.5	5.91	2.01	19.77	2.15	21.52	141.906	Horizontal	Pass	
QAM		847.5	5.39	2.02	19.81	2.15	21.03	126.765	Horizontal	Pass	
5.0MHz	1/#Mid	826.5	6.52	2.01	19.71	2.15	22.07	161.065	Horizontal	Pass	
Band 16		836.5	6.29	2.01	19.77	2.15	21.90	154.882	Horizontal	Pass	
QAM		846.5	6.04	2.02	19.79	2.15	21.66	146.555	Horizontal	Pass	
10.0MHz	1/#Mid	829	6.52	2.01	19.73	2.15	22.09	161.808	Horizontal	Pass	
Band 16		836.5	6.24	2.01	19.77	2.15	21.85	153.109	Horizontal	Pass	
QAM		844	5.78	2.02	19.78	2.15	21.39	137.721	Horizontal	Pass	
1.4MHz	1/#Mid	824.7	4.86	2.01	19.68	2.15	20.38	109.144	Vertical	Pass	
Band 16		836.5	4.39	2.01	19.77	2.15	20.00	100.000	Vertical	Pass	
QAM		848.3	5.57	2.02	19.82	2.15	21.22	132.434	Vertical	Pass	
3.0MHz	1/#Mid	825.5	5.08	2.01	19.70	2.15	20.62	115.345	Vertical	Pass	
Band 16		836.5	5.23	2.01	19.77	2.15	20.84	121.339	Vertical	Pass	
QAM		847.5	5.21	2.02	19.81	2.15	20.85	121.619	Vertical	Pass	
5.0MHz	1/#Mid	826.5	5.53	2.01	19.71	2.15	21.08	128.233	Vertical	Pass	
Band 16		836.5	4.17	2.01	19.77	2.15	19.78	95.060	Vertical	Pass	
QAM		846.5	5.32	2.02	19.79	2.15	20.94	124.165	Vertical	Pass	
10.0MHz	1/#Mid	829	6.00	2.01	19.73	2.15	21.57	143.549	Vertical	Pass	
Band 16		836.5	5.69	2.01	19.77	2.15	21.30	134.896	Vertical	Pass	
QAM		844	5.61	2.02	19.78	2.15	21.22	132.434	Vertical	Pass	

Note:

SG Level= Signal generator output

Max. EIRP Average (dBm)= Antenna Gain(dB)+ SG Level (dBm)- Cable Loss(dBm)

Factor Gain(dB)=Antenna Gain(dB) + Amplifier Factor (dB)

8.5 LTE BAND 7

Radiated Power (EIRP) for Band 7									
Mode	RB/RB SIZE	Frequency	Result						Conclusion
			SG Level	Cable Loss	Antenna Factor	Max. EIRP	Max. EIRP	Polarization Of Max. ERP	
			(dBm)	(dBm)	(dB)	Average	Average		
						(dBm)	(mW)		
5.0MHz Band QPSK	1/#Mid	2502.5	-0.61	4.54	27.75	22.60	181.970	Horizontal	Pass
		2535	-0.44	4.69	27.72	22.59	181.552	Horizontal	Pass
		2567.5	-0.37	4.71	27.71	22.63	183.231	Horizontal	Pass
10.0MHz Band QPSK	1/#Mid	2505	-0.54	4.55	27.76	22.67	184.927	Horizontal	Pass
		2535	-0.35	4.69	27.72	22.68	185.353	Horizontal	Pass
		2565	-0.27	4.72	27.70	22.71	186.638	Horizontal	Pass
15.0MHz Band QPSK	1/#Mid	2507.5	-0.55	4.55	27.77	22.67	184.927	Horizontal	Pass
		2535	-0.41	4.69	27.72	22.62	182.810	Horizontal	Pass
		2562.5	-0.31	4.72	27.69	22.66	184.502	Horizontal	Pass
20.0MHz Band QPSK	1/#Mid	2510	-0.49	4.57	27.78	22.72	187.068	Horizontal	Pass
		2535	-0.31	4.73	27.72	22.68	185.353	Horizontal	Pass
		2560	-0.27	4.75	27.68	22.66	184.502	Horizontal	Pass
5.0MHz Band QPSK	1/#Mid	2502.5	-2.42	4.54	27.75	20.79	119.950	Vertical	Pass
		2535	-2.21	4.69	27.72	20.82	120.781	Vertical	Pass
		2567.5	-1.44	4.71	27.71	21.56	143.219	Vertical	Pass
10.0MHz Band QPSK	1/#Mid	2505	-1.71	4.55	27.76	21.50	141.254	Vertical	Pass
		2535	-1.59	4.69	27.72	21.44	139.316	Vertical	Pass
		2565	-1.31	4.72	27.70	21.67	146.893	Vertical	Pass
15.0MHz Band QPSK	1/#Mid	2507.5	-1.80	4.55	27.77	21.42	138.676	Vertical	Pass
		2535	-1.87	4.69	27.72	21.16	130.617	Vertical	Pass
		2562.5	-1.31	4.72	27.69	21.66	146.555	Vertical	Pass
20.0MHz Band QPSK	1/#Mid	2510	-1.95	4.57	27.78	21.26	133.660	Vertical	Pass
		2535	-1.90	4.73	27.72	21.09	128.529	Vertical	Pass
		2560	-2.04	4.75	27.68	20.89	122.744	Vertical	Pass

Radiated Power (EIRP) for Band 7									
Mode	RB/RB SIZE	Frequency	Result						Conclusion
			SG Level	Cable Loss	Antenna Factor	Max. EIRP	Max. EIRP	Polarization	
			(dBm)	(dBm)	(dB)	Average	Average	Of Max. ERP	
						(dBm)	(mW)		
5.0MHz Band 16 QAM	1/#Mid	2502.5	-1.30	4.54	27.75	21.91	155.239	Horizontal	Pass
		2535	-0.99	4.69	27.72	22.04	159.956	Horizontal	Pass
		2567.5	-1.07	4.71	27.71	21.93	155.955	Horizontal	Pass
10.0MHz Band 16 QAM	1/#Mid	2505	-1.19	4.55	27.76	22.02	159.221	Horizontal	Pass
		2535	-1.20	4.69	27.72	21.83	152.405	Horizontal	Pass
		2565	-1.47	4.72	27.70	21.51	141.579	Horizontal	Pass
15.0MHz Band 16 QAM	1/#Mid	2507.5	-1.37	4.55	27.77	21.85	153.109	Horizontal	Pass
		2535	-1.34	4.69	27.72	21.69	147.571	Horizontal	Pass
		2562.5	-0.95	4.72	27.69	22.02	159.221	Horizontal	Pass
20.0MHz Band 16 QAM	1/#Mid	2510	-1.25	4.57	27.78	21.96	157.036	Horizontal	Pass
		2535	-0.92	4.73	27.72	22.07	161.065	Horizontal	Pass
		2560	-1.02	4.75	27.68	21.91	155.239	Horizontal	Pass
5.0MHz Band 16 QAM	1/#Mid	2502.5	-1.97	4.54	27.75	21.24	133.045	Vertical	Pass
		2535	-2.51	4.69	27.72	20.52	112.720	Vertical	Pass
		2567.5	-2.10	4.71	27.71	20.90	123.027	Vertical	Pass
10.0MHz Band 16 QAM	1/#Mid	2505	-3.23	4.55	27.76	19.98	99.541	Vertical	Pass
		2535	-1.53	4.69	27.72	21.50	141.254	Vertical	Pass
		2565	-3.18	4.72	27.70	19.80	95.499	Vertical	Pass
15.0MHz Band 16 QAM	1/#Mid	2507.5	-1.72	4.55	27.77	21.50	141.254	Vertical	Pass
		2535	-1.95	4.69	27.72	21.08	128.233	Vertical	Pass
		2562.5	-2.61	4.72	27.69	20.36	108.643	Vertical	Pass
20.0MHz Band 16 QAM	1/#Mid	2510	-2.87	4.57	27.78	20.34	108.143	Vertical	Pass
		2535	-3.13	4.73	27.72	19.86	96.828	Vertical	Pass
		2560	-2.78	4.75	27.68	20.15	103.514	Vertical	Pass

Note:

SG Level= Signal generator output

Max. EIRP Average (dBm)= Antenna Factor (dB)+ SG Level (dBm)- Cable Loss(dBm)

8.6 LTE BAND 12

Radiated Power (ERP) for Band 12											
Mode	RB/RB SIZE	Frequency	Result							Polarization	Conclusion
			SG Level	Cable Loss	Antenna Factor	Correction	Max. EIRP	Max. EIRP	Of Max. ERP		
			(dBm)	(dBm)	(dB)	(dB)	Average	Average			
							(dBm)	(mW)			
1.4MHz Band QPSK	1/#Mid	699.7	7.47	1.91	19.21	2.15	22.62	182.810	Vertical	Pass	
		707.5	7.39	1.91	19.26	2.15	22.59	181.552	Vertical	Pass	
		715.3	7.17	1.93	19.34	2.15	22.43	174.985	Vertical	Pass	
3.0MHz Band QPSK	1/#Mid	700.5	7.26	1.91	19.21	2.15	22.41	174.181	Vertical	Pass	
		707.5	7.18	1.91	19.26	2.15	22.38	172.982	Vertical	Pass	
		714.5	7.02	1.93	19.34	2.15	22.28	169.044	Vertical	Pass	
5.0MHz Band QPSK	1/#Mid	701.5	7.53	1.91	19.23	2.15	22.70	186.209	Vertical	Pass	
		707.5	7.44	1.91	19.26	2.15	22.64	183.654	Vertical	Pass	
		713.5	7.23	1.92	19.33	2.15	22.49	177.419	Vertical	Pass	
10.0MHz Band QPSK	1/#Mid	704	7.55	1.91	19.25	2.15	22.74	187.932	Vertical	Pass	
		707.5	7.53	1.91	19.26	2.15	22.73	187.499	Vertical	Pass	
		711	7.38	1.92	19.32	2.15	22.63	183.231	Vertical	Pass	
1.4MHz Band QPSK	1/#Mid	699.7	6.12	1.91	19.21	2.15	21.27	133.968	Horizontal	Pass	
		707.5	6.69	1.91	19.26	2.15	21.89	154.525	Horizontal	Pass	
		715.3	5.80	1.93	19.34	2.15	21.06	127.644	Horizontal	Pass	
3.0MHz Band QPSK	1/#Mid	700.5	6.49	1.91	19.21	2.15	21.64	145.881	Horizontal	Pass	
		707.5	6.22	1.91	19.26	2.15	21.42	138.676	Horizontal	Pass	
		714.5	6.44	1.93	19.34	2.15	21.70	147.911	Horizontal	Pass	
5.0MHz Band QPSK	1/#Mid	701.5	6.49	1.91	19.23	2.15	21.66	146.555	Horizontal	Pass	
		707.5	6.53	1.91	19.26	2.15	21.73	148.936	Horizontal	Pass	
		713.5	5.77	1.92	19.33	2.15	21.03	126.765	Horizontal	Pass	
10.0MHz Band QPSK	1/#Mid	704	6.30	1.91	19.25	2.15	21.49	140.929	Horizontal	Pass	
		707.5	6.07	1.91	19.26	2.15	21.27	133.968	Horizontal	Pass	
		711	6.22	1.92	19.32	2.15	21.47	140.281	Horizontal	Pass	

Radiated Power (ERP) for Band 12										
Mode	RB/RB SIZE	Frequency	Result							Conclusion
			SG Level	Cable Loss	Antenna Factor	Correction	Max. EIRP	Max. EIRP	Polarization	
			(dBm)	(dBm)	(dB)	(dB)	Average	Average	Of Max. ERP	
							(dBm)	(mW)		
1.4MHz Band 16 QAM	1/#Mid	699.7	7.43	1.91	19.21	2.15	22.58	181.134	Vertical	Pass
		707.5	7.35	1.91	19.26	2.15	22.55	179.887	Vertical	Pass
		715.3	7.13	1.93	19.34	2.15	22.39	173.380	Vertical	Pass
3.0MHz Band 16 QAM	1/#Mid	700.5	7.22	1.91	19.21	2.15	22.37	172.584	Vertical	Pass
		707.5	7.14	1.91	19.26	2.15	22.34	171.396	Vertical	Pass
		714.5	6.98	1.93	19.34	2.15	22.24	167.494	Vertical	Pass
5.0MHz Band 16 QAM	1/#Mid	701.5	7.49	1.91	19.23	2.15	22.66	184.502	Vertical	Pass
		707.5	7.40	1.91	19.26	2.15	22.60	181.970	Vertical	Pass
		713.5	7.19	1.92	19.33	2.15	22.45	175.792	Vertical	Pass
10.0MHz Band 16 QAM	1/#Mid	704	7.51	1.91	19.25	2.15	22.70	186.209	Vertical	Pass
		707.5	7.49	1.91	19.26	2.15	22.69	185.780	Vertical	Pass
		711	7.34	1.92	19.32	2.15	22.59	181.552	Vertical	Pass
1.4MHz Band 16 QAM	1/#Mid	699.7	6.38	1.91	19.21	2.15	21.53	142.233	Horizontal	Pass
		707.5	6.30	1.91	19.26	2.15	21.50	141.254	Horizontal	Pass
		715.3	5.63	1.93	19.34	2.15	20.89	122.744	Horizontal	Pass
3.0MHz Band 16 QAM	1/#Mid	700.5	6.32	1.91	19.21	2.15	21.47	140.281	Horizontal	Pass
		707.5	6.01	1.91	19.26	2.15	21.21	132.130	Horizontal	Pass
		714.5	5.94	1.93	19.34	2.15	21.20	131.826	Horizontal	Pass
5.0MHz Band 16 QAM	1/#Mid	701.5	6.19	1.91	19.23	2.15	21.36	136.773	Horizontal	Pass
		707.5	6.67	1.91	19.26	2.15	21.87	153.815	Horizontal	Pass
		713.5	6.02	1.92	19.33	2.15	21.28	134.276	Horizontal	Pass
10.0MHz Band 16 QAM	1/#Mid	704	6.20	1.91	19.25	2.15	21.39	137.721	Horizontal	Pass
		707.5	6.35	1.91	19.26	2.15	21.55	142.889	Horizontal	Pass
		711	6.59	1.92	19.32	2.15	21.84	152.757	Horizontal	Pass

Note:

SG Level= Signal generator output

Max. EIRP Average (dBm)= Antenna Gain(dB)+ SG Level (dBm)- Cable Loss(dBm)

Factor Gain(dB)=Antenna Gain(dB) + Amplifier Factor (dB)

8.7 LTE BAND 17

Radiated Power (ERP) for Band 17										
Mode	RB/RB SIZE	Frequency	Result							Conclusion
			SG Level	Cable Loss	Antenna Factor	Correction	Max. EIRP	Max. EIRP	Polarization	
			(dBm)	(dBm)	(dB)		Average	Average	Of Max. ERP	
							(dBm)	(mW)		
5.0MHz Band QPSK	1/#Mid	706.5	7.44	1.91	19.23	2.15	22.61	182.390	Vertical	Pass
		710	7.30	1.91	19.26	2.15	22.50	177.828	Vertical	Pass
		713.5	7.20	1.92	19.33	2.15	22.46	176.198	Vertical	Pass
10.0MHz Band QPSK	1/#Mid	709	7.45	1.91	19.25	2.15	22.64	183.654	Vertical	Pass
		710	7.40	1.91	19.26	2.15	22.60	181.970	Vertical	Pass
		711	7.36	1.92	19.32	2.15	22.61	182.390	Vertical	Pass
5.0MHz Band QPSK	1/#Mid	706.5	6.51	1.91	19.23	2.15	21.68	147.231	Horizontal	Pass
		710	5.67	1.91	19.26	2.15	20.87	122.180	Horizontal	Pass
		713.5	6.55	1.92	19.33	2.15	21.81	151.705	Horizontal	Pass
10.0MHz Band QPSK	1/#Mid	709	6.72	1.91	19.25	2.15	21.91	155.239	Horizontal	Pass
		710	5.93	1.91	19.26	2.15	21.13	129.718	Horizontal	Pass
		711	6.31	1.92	19.32	2.15	21.56	143.219	Horizontal	Pass

Radiated Power (ERP) for Band 17											
Mode	RB/RB SIZE	Frequency	Result							Polarization Of Max. ERP	Conclusion
			SG Level (dBm)	Cable Loss (dBm)	Antenna Factor (dB)	Correction (dB)	Max. EIRP	Max. EIRP			
					Average		Average				
					(dBm)		(mW)				
5.0MHz Band 16 QAM	1/#Mid	706.5	6.79	1.91	19.23	2.15	21.96	157.036	Vertical	Pass	
		710	6.70	1.91	19.26	2.15	21.90	154.882	Vertical	Pass	
		713.5	6.50	1.92	19.33	2.15	21.76	149.968	Vertical	Pass	
10.0MHz Band 16 QAM	1/#Mid	709	6.33	1.91	19.25	2.15	21.52	141.906	Vertical	Pass	
		710	6.86	1.91	19.26	2.15	22.06	160.694	Vertical	Pass	
		711	6.59	1.92	19.32	2.15	21.84	152.757	Vertical	Pass	
5.0MHz Band 16 QAM	1/#Mid	706.5	6.08	1.91	19.23	2.15	21.25	133.352	Horizontal	Pass	
		710	5.37	1.91	19.26	2.15	20.57	114.025	Horizontal	Pass	
		713.5	5.78	1.92	19.33	2.15	21.04	127.057	Horizontal	Pass	
10.0MHz Band 16 QAM	1/#Mid	709	5.60	1.91	19.25	2.15	20.79	119.950	Horizontal	Pass	
		710	5.72	1.91	19.26	2.15	20.92	123.595	Horizontal	Pass	
		711	5.38	1.92	19.32	2.15	20.63	115.611	Horizontal	Pass	

Note:

ERP=EIRP-2.15

SG Level= Signal generator output

Max. EIRP Average (dBm)= Antenna Factor (dB)+ SG Level (dBm)- Cable Loss(dBm)

8.8 LTE BAND 66

Radiated Power (EIRP) for Band 66									
Mode	RB/RB SIZE	Frequency	Result						Conclusion
			SG Level (dBm)	Cable Loss (dBm)	Antenna Factor (dB)	Max. EIRP Average (dBm)	Max. EIRP Average (mW)	Polarization Of Max. ERP	
1.4MHz Band QPSK	1/#Mid	1710.7	-2.18	3.76	28.24	22.30	169.824	Horizontal	Pass
		1745	-2.04	3.91	28.22	22.27	168.655	Horizontal	Pass
		1779.3	-1.91	3.93	28.2	22.36	172.187	Horizontal	Pass
3.0MHz Band QPSK	1/#Mid	1711.5	-2.24	3.77	28.23	22.22	166.725	Horizontal	Pass
		1745	-2.15	3.91	28.24	22.18	165.196	Horizontal	Pass
		1778.5	-2.17	3.94	28.25	22.14	163.682	Horizontal	Pass
5.0MHz Band QPSK	1/#Mid	1712.5	-2.14	3.77	28.31	22.40	173.780	Horizontal	Pass
		1745	-1.82	3.91	28.22	22.49	177.419	Horizontal	Pass
		1777.5	-1.88	3.94	28.2	22.38	172.982	Horizontal	Pass
10.0MHz Band QPSK	1/#Mid	1715	-2.03	3.79	28.33	22.51	178.238	Horizontal	Pass
		1745	-1.76	3.95	28.22	22.51	178.238	Horizontal	Pass
		1775	-1.77	3.97	28.19	22.45	175.792	Horizontal	Pass
15.0MHz Band QPSK	1/#Mid	1717.5	-2.05	3.79	28.34	22.50	177.828	Horizontal	Pass
		1745	-1.86	3.95	28.22	22.41	174.181	Horizontal	Pass
		1772.5	-1.81	3.97	28.18	22.40	173.780	Horizontal	Pass
20.0MHz Band QPSK	1/#Mid	1720	-2.02	3.81	28.35	22.52	178.649	Horizontal	Pass
		1745	-1.76	3.96	28.22	22.50	177.828	Horizontal	Pass
		1770	-1.78	4	28.16	22.38	172.982	Horizontal	Pass
1.4MHz Band QPSK	1/#Mid	1710.7	-3.63	3.76	28.24	20.85	121.619	Vertical	Pass
		1745	-2.95	3.91	28.22	21.36	136.773	Vertical	Pass
		1779.3	-2.68	3.93	28.2	21.59	144.212	Vertical	Pass
3.0MHz Band QPSK	1/#Mid	1711.5	-3.07	3.77	28.23	21.39	137.721	Vertical	Pass
		1745	-3.19	3.91	28.24	21.14	130.017	Vertical	Pass
		1778.5	-2.65	3.94	28.25	21.66	146.555	Vertical	Pass
5.0MHz Band QPSK	1/#Mid	1712.5	-3.38	3.77	28.31	21.16	130.617	Vertical	Pass
		1745	-2.85	3.91	28.22	21.46	139.959	Vertical	Pass
		1777.5	-3.10	3.94	28.2	21.16	130.617	Vertical	Pass
10.0MHz Band QPSK	1/#Mid	1715	-3.00	3.79	28.34	21.55	142.889	Vertical	Pass
		1745	-2.75	3.95	28.22	21.52	141.906	Vertical	Pass
		1775	-3.13	3.97	28.18	21.08	128.233	Vertical	Pass

15.0MHz		1717.5	-2.93	3.81	28.35	21.61	144.877	Vertical	Pass
Band	1/#Mid	1745	-2.96	3.96	28.22	21.30	134.896	Vertical	Pass
QPSK		1772.5	-2.54	4	28.16	21.62	145.211	Vertical	Pass
20.0MHz		1720	-2.82	3.79	28.34	21.73	148.936	Vertical	Pass
Band	1/#Mid	1745	-3.45	3.95	28.22	20.82	120.781	Vertical	Pass
QPSK		1770	-2.49	3.97	28.18	21.72	148.594	Vertical	Pass

Radiated Power (EIRP) for Band 66									
Mode	RB/RB SIZE	Frequency	Result						Conclusion
			SG Level (dBm)	Cable Loss (dBm)	Antenna Factor (dB)	Max. EIRP Average (dBm)	Max. EIRP	Polarization Of Max. ERP	
							(mW)		
1.4MHz Band 16 QAM	1/#Mid	1710.7	-3.01	3.76	28.24	21.47	140.281	Horizontal	Pass
		1745	-2.62	3.91	28.22	21.69	147.571	Horizontal	Pass
		1779.3	-2.80	3.93	28.2	21.47	140.281	Horizontal	Pass
3.0MHz Band 16 QAM	1/#Mid	1711.5	-3.40	3.77	28.23	21.06	127.644	Horizontal	Pass
		1745	-2.65	3.91	28.24	21.68	147.231	Horizontal	Pass
		1778.5	-2.94	3.94	28.25	21.37	137.088	Horizontal	Pass
5.0MHz Band 16 QAM	1/#Mid	1712.5	-2.82	3.77	28.31	21.72	148.594	Horizontal	Pass
		1745	-2.88	3.91	28.22	21.43	138.995	Horizontal	Pass
		1777.5	-2.55	3.94	28.2	21.71	148.252	Horizontal	Pass
10.0MHz Band 16 QAM	1/#Mid	1715	-2.87	3.79	28.33	21.67	146.893	Horizontal	Pass
		1745	-2.53	3.95	28.22	21.74	149.279	Horizontal	Pass
		1775	-2.85	3.97	28.19	21.37	137.088	Horizontal	Pass
15.0MHz Band 16 QAM	1/#Mid	1717.5	-2.86	3.79	28.34	21.69	147.571	Horizontal	Pass
		1745	-2.68	3.95	28.22	21.59	144.212	Horizontal	Pass
		1772.5	-2.47	3.97	28.18	21.74	149.279	Horizontal	Pass
20.0MHz Band 16 QAM	1/#Mid	1720	-2.69	3.81	28.35	21.85	153.109	Horizontal	Pass
		1745	-2.47	3.96	28.22	21.79	151.008	Horizontal	Pass
		1770	-2.41	4	28.16	21.75	149.624	Horizontal	Pass
1.4MHz Band 16 QAM	1/#Mid	1710.7	-4.40	3.76	28.24	20.08	101.859	Vertical	Pass
		1745	-2.59	3.91	28.22	21.72	148.594	Vertical	Pass
		1779.3	-4.01	3.93	28.2	20.26	106.170	Vertical	Pass
3.0MHz Band 16 QAM	1/#Mid	1711.5	-3.38	3.77	28.23	21.08	128.233	Vertical	Pass
		1745	-2.74	3.91	28.24	21.59	144.212	Vertical	Pass
		1778.5	-2.94	3.94	28.25	21.37	137.088	Vertical	Pass
5.0MHz Band 16 QAM	1/#Mid	1712.5	-4.15	3.77	28.31	20.39	109.396	Vertical	Pass
		1745	-3.72	3.91	28.22	20.59	114.551	Vertical	Pass
		1777.5	-4.20	3.94	28.2	20.06	101.391	Vertical	Pass
10.0MHz Band 16 QAM	1/#Mid	1715	-4.25	3.79	28.34	20.30	107.152	Vertical	Pass
		1745	-3.00	3.95	28.22	21.27	133.968	Vertical	Pass
		1775	-4.35	3.97	28.18	19.86	96.828	Vertical	Pass
15.0MHz Band 16	1/#Mid	1717.5	-4.72	3.81	28.35	19.82	95.940	Vertical	Pass
		1745	-3.82	3.96	28.22	20.44	110.662	Vertical	Pass

QAM		1772.5	-3.68	4	28.16	20.48	111.686	Vertical	Pass
20.0MHz	1/#Mid	1720	-3.58	3.79	28.34	20.97	125.026	Vertical	Pass
Band 16		1745	-3.29	3.95	28.22	20.98	125.314	Vertical	Pass
QAM		1770	-3.99	3.97	28.18	20.22	105.196	Vertical	Pass

Note:

SG Level= Signal generator output

Max. EIRP Average (dBm)= Antenna Gain(dB)+ SG Level (dBm)- Cable Loss(dBm)

Factor Gain(dB)=Antenna Gain(dB) + Amplifier Factor (dB)

9. SPURIOUS RADIATION EMISSION

RULE PART(S)

FCC: §2.1053, §22.917, §24.238, §27.53

LIMIT

§22.917 (e) and §24.238 and §90.691 (a): Out of band emissions. The power of any emission outside of the authorized operating frequency ranges must be attenuated below the transmitting power (P) by a factor of at least $43 + 10 \log (P)$ dB.

§27.53 (g) For operations in the 698–746 MHz band, the power of any emission outside a licensee's frequency band(s) of operation shall be attenuated below the transmitter power (P) within the licensed band(s) of operation, measured in watts, by at least $43 + 10 \log (P)$ dB.

§27.53 (h) For operations in the 1710–1755 MHz and 2110–2155 MHz bands, the power of any emission outside a licensee's frequency block shall be attenuated below the transmitter power (P) by at least $43 + 10 \log_{10}(P)$ dB.

TEST PROCEDURE

For Cellular equipment - Compliance with these rules is based on the use of measurement instrumentation employing a resolution bandwidth of 100 kHz or greater. In the 1 MHz bands immediately outside and adjacent to the frequency block a resolution bandwidth of at least one percent of the emission bandwidth of the fundamental emission of the transmitter may be employed. A narrower resolution bandwidth is permitted in all cases to improve measurement accuracy provided the measured power is integrated over the full required measurement bandwidth (i.e. 100 kHz or 1 percent of emission bandwidth, as specified). The emission bandwidth is defined as the width of the signal between two points, one below the carrier center frequency and one above the carrier center frequency, outside of which all emissions are attenuated at least 26 dB below the transmitter power.

For PCS equipment - Compliance with these rules is based on the use of measurement instrumentation employing a resolution bandwidth of 1 MHz or greater. However, in the 1 MHz bands immediately outside and adjacent to the frequency block a resolution bandwidth of at least one percent of the emission bandwidth of the fundamental emission of the transmitter may be employed. A narrower resolution bandwidth is permitted in all cases to improve measurement accuracy provided the measured power is integrated over the full required measurement bandwidth (i.e. 1 MHz or 1 percent of emission bandwidth, as specified). The emission bandwidth is defined as the width of the signal between two points, one below the carrier center frequency and one above the carrier center frequency, outside of which all emissions are attenuated at least 26 dB below the transmitter power.

The unwanted emission power shall be measured with a resolution bandwidth of at least 1% of the occupied bandwidth in the 1 MHz band immediately outside and adjacent to the channel edge of the equipment. Beyond the 1 MHz band immediately outside the channel edge of the equipment, a resolution bandwidth of 1 MHz shall be employed. A narrower resolution bandwidth is allowed to be used provided that the measured power is integrated over the full required measurement bandwidth of 1 MHz or 1% of the occupied bandwidth as applicable.

The power of any unwanted emissions measured from the channel edge of the equipment shall be attenuated below the transmitter power, P (dBW), as follows:

- a. for base station and subscriber equipment, other than mobile subscriber equipment, the attenuation shall not be less than $43 + 10 \text{ Log}_{10} (p)$, dB; and
- b. for mobile subscriber equipment, the attenuation shall not be less than $43 + 10 \text{ Log}_{10} (p)$, dB at the channel edges and $55 + 10 \text{ Log}_{10} (p)$ at 5.5 MHz away and beyond the channel edges where p in (a) and (b) is the transmitter power measured in watts.

MODES TESTED

LTE Band 2/4/5/7/12/17/66

RESULTS

PASS

9.1 LTE BAND 2
QPSK EIRP POWER FOR LTE BAND 2 (1.4MHZ BANDWIDTH)

Test Results for Low Channel 1850.7MHz							
Frequency(MHz)	SG Level(dBm)	Cable Loss(dB)	Antenna Factor(dB)	Absolute Level(dBm)	Limit (dBm)	Margin(dBm)	Polarity
3701.4	-51.17	4.04	33.51	-21.70	-13	-8.70	Horizontal
3701.4	-49.89	4.04	33.51	-20.42	-13	-7.42	Vertical
5552.1	-52.62	5.24	35.84	-22.02	-13	-9.02	Vertical
5552.1	-49.27	5.24	35.84	-18.67	-13	-5.67	Horizontal
187.4	-43.82	1.43	16.02	-29.23	-13	-16.23	Vertical
388.7	-39.67	1.30	17.99	-22.98	-13	-9.98	Horizontal
Test Results for Mid Channel 1880MHz							
3760.0	-53.54	4.04	33.56	-24.02	-13	-11.02	Horizontal
3760.0	-50.82	4.04	33.56	-21.30	-13	-8.30	Vertical
5640.0	-47.92	5.24	35.91	-17.25	-13	-4.25	Vertical
5640.0	-49.03	5.24	35.91	-18.36	-13	-5.36	Horizontal
185.0	-40.28	1.62	16.97	-24.93	-13	-11.93	Vertical
311.1	-43.95	1.74	15.98	-29.72	-13	-16.72	Horizontal
Test Results for High Channel 1909.3MHz							
3818.6	-53.71	4.04	34.00	-23.75	-13	-10.75	Horizontal
3818.6	-51.37	4.04	34.00	-21.41	-13	-8.41	Vertical
5727.9	-47.11	5.24	36.04	-16.31	-13	-3.31	Vertical
5727.9	-52.84	5.24	36.04	-22.04	-13	-9.04	Horizontal
194.0	-43.03	1.42	17.29	-27.16	-13	-14.16	Vertical
330.2	-43.11	1.50	17.90	-26.70	-13	-13.70	Horizontal

QPSK EIRP POWER FOR LTE BAND 2 (20.0MHZ BANDWIDTH)

Test Results for Low Channel 1860MHz							
Frequency(MHz)	SG Level(dBm)	Cable Loss(dB)	Antenna Factor(dB)	Absolute Level(dBm)	Limit (dBm)	Margin(dBm)	Polarity
3720.0	-49.50	4.07	33.54	-20.03	-13	-7.03	Horizontal
3720.0	-51.47	4.07	33.54	-22.00	-13	-9.00	Vertical
5580.0	-49.61	5.28	35.86	-19.03	-13	-6.03	Vertical
5580.0	-51.71	5.28	35.86	-21.13	-13	-8.13	Horizontal
206.2	-40.95	1.58	16.89	-25.63	-13	-12.63	Vertical
410.3	-34.85	1.76	17.26	-19.35	-13	-6.35	Horizontal
Test Results for Mid Channel 1880MHz							
3760.0	-46.45	4.04	33.56	-16.93	-13	-3.93	Horizontal
3760.0	-49.33	4.04	33.56	-19.81	-13	-6.81	Vertical
5640.0	-47.71	5.24	35.91	-17.04	-13	-4.04	Vertical
5640.0	-51.78	5.24	35.91	-21.11	-13	-8.11	Horizontal
209.5	-34.97	1.46	16.27	-20.16	-13	-7.16	Vertical
344.6	-37.46	1.59	15.15	-23.90	-13	-10.90	Horizontal
Test Results for High Channel 1900MHz							
3800.0	-49.80	4.04	34.00	-19.84	-13	-6.84	Horizontal
3800.0	-52.40	4.04	34.00	-22.44	-13	-9.44	Vertical
5700.0	-47.02	5.24	36.04	-16.22	-13	-3.22	Vertical
5700.0	-49.97	5.24	36.04	-19.17	-13	-6.17	Horizontal
188.7	-40.19	1.36	17.39	-24.15	-13	-11.15	Vertical
465.7	-44.85	1.66	15.39	-31.12	-13	-18.12	Horizontal

Note: P_{Mea}(dBm)= Power(dBm)+ ARpl (dBm)

. Over Limit= : P_{Mea}(dBm)-Limit(dBm)

. Both QPSK and 16QAM has been tested, the worst case is QPSK mode, the report just reported the worst case.

9.2 LTE BAND 4

QPSK EIRP POWER FOR LTE BAND 4 (1.4MHZ BANDWIDTH)

Test Results for Low Channel 1710.7MHz							
Frequency(MHz)	SG Level(dBm)	Cable Loss(dB)	Antenna Factor(dB)	Absolute Level(dBm)	Limit (dBm)	Margin(dBm)	Polarity
3421.4	-50.77	4.02	29.80	-24.99	-13	-11.99	Horizontal
3421.4	-46.23	4.02	29.80	-20.45	-13	-7.45	Vertical
5132.1	-47.21	5.24	35.84	-16.61	-13	-3.61	Vertical
5132.1	-51.99	5.24	35.84	-21.39	-13	-8.39	Horizontal
200.4	-37.20	1.68	16.04	-22.84	-13	-9.84	Vertical
311.1	-39.98	1.78	17.74	-24.02	-13	-11.02	Horizontal
Test Results for Mid Channel 1732.5MHz							
3465.0	-48.17	4.03	30.00	-22.20	-13	-9.20	Horizontal
3465.0	-49.71	4.03	30.00	-23.74	-13	-10.74	Vertical
5197.5	-50.02	5.25	35.86	-19.41	-13	-6.41	Vertical
5197.5	-49.99	5.25	35.86	-19.38	-13	-6.38	Horizontal
181.5	-38.28	1.72	17.69	-22.31	-13	-9.31	Vertical
319.2	-40.16	1.62	16.02	-25.75	-13	-12.75	Horizontal
Test Results for High Channel 1754.3MHz							
3508.6	-52.45	4.05	30.01	-26.49	-13	-13.49	Horizontal
3508.6	-53.60	4.05	30.01	-27.64	-13	-14.64	Vertical
5262.9	-49.49	5.26	35.86	-18.89	-13	-5.89	Vertical
5262.9	-53.48	5.26	35.86	-22.88	-13	-9.88	Horizontal
196.2	-42.40	1.80	16.69	-27.51	-13	-14.51	Vertical
357.6	-35.21	1.75	16.66	-20.31	-13	-7.31	Horizontal

QPSK EIRP POWER FOR LTE BAND 4 (20.0MHZ BANDWIDTH)

Test Results for Low Channel 1720MHz							
Frequency(MHz)	SG Level(dBm)	Cable Loss(dB)	Antenna Factor(dB)	Absolute Level(dBm)	Limit (dBm)	Margin(dBm)	Polarity
3440.0	-50.81	4.02	29.80	-25.03	-13	-12.03	Horizontal
3440.0	-51.13	4.02	29.80	-25.35	-13	-12.35	Vertical
5160.0	-53.38	5.24	35.84	-22.78	-13	-9.78	Vertical
5160.0	-53.60	5.24	35.84	-23.00	-13	-10.00	Horizontal
211.8	-44.57	1.57	17.26	-28.88	-13	-15.88	Vertical
267.6	-43.21	1.78	16.35	-28.64	-13	-15.64	Horizontal
Test Results for Mid Channel 1732.5MHz							
3465.0	-48.11	4.03	30.00	-22.14	-13	-9.14	Horizontal
3465.0	-47.00	4.03	30.00	-21.03	-13	-8.03	Vertical
5197.5	-53.46	5.25	35.86	-22.85	-13	-9.85	Vertical
5197.5	-50.48	5.25	35.86	-19.87	-13	-6.87	Horizontal
206.0	-35.75	1.44	17.95	-19.24	-13	-6.24	Vertical
423.5	-37.29	1.65	16.09	-22.85	-13	-9.85	Horizontal
Test Results for High Channel 1745MHz							
3490.0	-49.55	2.91	27.68	-24.78	-13	-11.78	Horizontal
3490.0	-53.90	2.91	27.68	-29.13	-13	-16.13	Vertical
5235.0	-51.23	5.26	35.86	-20.63	-13	-7.63	Vertical
5235.0	-53.07	5.26	35.86	-22.47	-13	-9.47	Horizontal
191.6	-44.67	1.61	16.85	-29.43	-13	-16.43	Vertical
394.1	-36.97	1.61	15.19	-23.39	-13	-10.39	Horizontal

Note: $P_{Mea}(dBm) = Power(dBm) + ARpl(dBm)$

Over Limit = $P_{Mea}(dBm) - Limit(dBm)$

Both QPSK and 16QAM has been tested, the worst case is QPSK mode, the report just reported the worst case.

9.3 LTE BAND 5
QPSK EIRP POWER FOR LTE BAND 5 (1.4MHZ BANDWIDTH)

Test Results for Low Channel 824.7MHz							
Frequency(MHz)	SG Level(dBm)	Cable Loss(dB)	Antenna Factor(dB)	Absolute Level(dBm)	Limit (dBm)	Margin(dBm)	Polarity
1649.4	-50.25	2.78	27.50	-25.53	-13	-12.53	Horizontal
1649.4	-44.87	2.78	27.50	-20.15	-13	-7.15	Vertical
2474.1	-45.97	2.90	27.80	-21.07	-13	-8.07	Vertical
2474.1	-52.72	2.90	27.80	-27.82	-13	-14.82	Horizontal
191.1	-39.31	1.76	17.59	-23.48	-13	-10.48	Vertical
323.3	-39.54	1.63	15.87	-25.30	-13	-12.30	Horizontal
Test Results For Mid Channel 836.5MHz							
1673.0	-44.66	2.80	27.48	-19.98	-13	-6.98	Horizontal
1673.0	-46.40	2.80	27.48	-21.72	-13	-8.72	Vertical
2509.5	-49.38	2.91	27.70	-24.59	-13	-11.59	Vertical
2509.5	-51.29	2.91	27.70	-26.50	-13	-13.50	Horizontal
177.3	-40.79	1.61	15.68	-26.72	-13	-13.72	Vertical
329.3	-44.52	1.59	17.52	-28.60	-13	-15.60	Horizontal
Test Results for High Channel 848.3MHz							
1696.6	-48.30	2.82	27.43	-23.69	-13	-10.69	Horizontal
1696.6	-47.45	2.82	27.43	-22.84	-13	-9.84	Vertical
2544.9	-51.58	2.92	27.74	-26.76	-13	-13.76	Vertical
2544.9	-51.30	2.92	27.74	-26.48	-13	-13.48	Horizontal
188.3	-38.37	1.69	16.67	-23.38	-13	-10.38	Vertical
342.6	-37.57	1.70	17.18	-22.09	-13	-9.09	Horizontal

QPSK EIRP POWER FOR LTE BAND 5 (10MHZ BANDWIDTH)

Test Results for Low Channel 829MHz							
Frequency(MHz)	SG Level(dBm)	Cable Loss(dB)	Antenna Factor(dB)	Absolute Level(dBm)	Limit (dBm)	Margin(dBm)	Polarity
1658.0	-45.40	2.78	27.50	-20.68	-13	-7.68	Horizontal
1658.0	-51.50	2.78	27.50	-26.78	-13	-13.78	Vertical
2487.0	-44.09	2.90	27.80	-19.19	-13	-6.19	Vertical
2487.0	-49.07	2.90	27.80	-24.17	-13	-11.17	Horizontal
199.0	-39.36	1.71	15.57	-25.50	-13	-12.50	Vertical
403.6	-43.27	1.34	16.40	-28.21	-13	-15.21	Horizontal
Test Results for Mid Channel 836.5MHz							
1673.0	-49.80	2.80	27.48	-25.12	-13	-12.12	Horizontal
1673.0	-51.20	2.80	27.48	-26.52	-13	-13.52	Vertical
2509.5	-48.66	2.91	27.70	-23.87	-13	-10.87	Vertical
2509.5	-50.11	2.91	27.70	-25.32	-13	-12.32	Horizontal
206.6	-43.61	1.44	17.04	-28.01	-13	-15.01	Vertical
277.0	-38.84	1.76	17.62	-22.98	-13	-9.98	Horizontal
Test Results for High Channel 844MHz							
1688.0	-51.36	2.82	27.43	-26.75	-13	-13.75	Horizontal
1688.0	-46.18	2.82	27.43	-21.57	-13	-8.57	Vertical
2532.0	-44.81	2.92	27.74	-19.99	-13	-6.99	Vertical
2532.0	-51.45	2.92	27.74	-26.63	-13	-13.63	Horizontal
205.7	-41.97	1.74	17.70	-26.01	-13	-13.01	Vertical
338.9	-36.42	1.41	17.46	-20.36	-13	-7.36	Horizontal

Note: P_{Mea}(dBm)= Power(dBm)+ ARpl (dBm)

Over Limit= : P_{Mea}(dBm)-Limit(dBm)

Both QPSK and 16QAM has been tested, the worst case is QPSK mode, the report just reported the worst case.

9.4 LTE BAND 7

QPSK EIRP POWER FOR LTE BAND 7 (5.0MHZ BANDWIDTH)

Test Results for Low Channel 2502.5MHz							
Frequency(MHz)	SG Level(dBm)	Cable Loss(dB)	Antenna Factor(dB)	Absolute Level(dBm)	Limit (dBm)	Margin(dBm)	Polarity
5005.0	-64.87	5.23	35.81	-34.29	-25	-9.29	Horizontal
5005.0	-62.62	5.23	35.81	-32.04	-25	-7.04	Vertical
7507.5	-60.70	5.67	36.85	-29.52	-25	-4.52	Vertical
7507.5	-59.31	5.67	36.85	-28.13	-25	-3.13	Horizontal
194.3	-53.62	1.73	17.97	-37.38	-25	-12.38	Vertical
467.2	-47.99	1.38	15.11	-34.26	-25	-9.26	Horizontal
Test Results for Mid Channel 2535MHz							
5070.0	-61.08	5.23	35.82	-30.49	-25	-5.49	Horizontal
5070.0	-59.73	5.23	35.82	-29.14	-25	-4.14	Vertical
7605.0	-60.71	5.67	36.85	-29.53	-25	-4.53	Vertical
7605.0	-63.63	5.67	36.85	-32.45	-25	-7.45	Horizontal
211.0	-44.37	1.77	16.17	-29.96	-25	-4.96	Vertical
336.9	-46.17	1.63	15.21	-32.59	-25	-7.59	Horizontal
Test Results for High Channel 2567.5MHz							
5135.0	-64.66	5.24	35.83	-34.07	-25	-9.07	Horizontal
5135.0	-61.84	5.24	35.83	-31.25	-25	-6.25	Vertical
7702.5	-60.69	5.68	36.87	-29.50	-25	-4.50	Vertical
7702.5	-61.55	5.68	36.87	-30.36	-25	-5.36	Horizontal
186.8	-44.99	1.58	17.56	-29.01	-25	-4.01	Vertical
279.1	-54.82	1.45	16.58	-39.69	-25	-14.69	Horizontal

QPSK EIRP POWER FOR LTE BAND 7 (20.0MHZ BANDWIDTH)

Test Results for Low Channel 2510MHz							
Frequency(MHz)	SG Level(dBm)	Cable Loss(dB)	Antenna Factor(dB)	Absolute Level(dBm)	Limit (dBm)	Margin(dBm)	Polarity
5020.0	-63.04	5.23	35.82	-32.45	-25	-7.45	Horizontal
5020.0	-63.61	5.23	35.82	-33.02	-25	-8.02	Vertical
7530.0	-61.34	5.67	36.86	-30.15	-25	-5.15	Vertical
7530.0	-59.65	5.67	36.86	-28.46	-25	-3.46	Horizontal
205.2	-51.07	1.63	15.76	-36.94	-25	-11.94	Vertical
407.8	-47.80	1.71	15.44	-34.07	-25	-9.07	Horizontal
Test Results for Mid Channel 2535MHz							
5070.0	-63.63	5.23	35.82	-33.04	-25	-8.04	Horizontal
5070.0	-62.21	5.23	35.82	-31.62	-25	-6.62	Vertical
7605.0	-62.02	5.67	36.85	-30.84	-25	-5.84	Vertical
7605.0	-60.23	5.67	36.85	-29.05	-25	-4.05	Horizontal
209.2	-53.08	1.79	16.84	-38.02	-25	-13.02	Vertical
262.5	-47.83	1.71	17.64	-31.90	-25	-6.90	Horizontal
Test Results for High Channel 2560MHz							
5120.0	-64.50	5.24	35.83	-33.91	-25	-8.91	Horizontal
5120.0	-64.80	5.24	35.83	-34.21	-25	-9.21	Vertical
7680.0	-62.95	5.70	36.88	-31.77	-25	-6.77	Vertical
7680.0	-61.79	5.70	36.88	-30.61	-25	-5.61	Horizontal
208.5	-45.73	1.79	16.84	-30.67	-25	-5.67	Vertical
337.1	-47.24	1.71	17.64	-31.31	-25	-6.31	Horizontal

Note: Spurious Emission Level = Spectrum Analyzer Read Value + Cable Loss+ Antenna Factor + 11.74

. Margin = Spurious Emission Level - Limit

. Both QPSK and 16QAM has been tested, the worst case is QPSK mode, the report just reported the worst case.

9.5 LTE BAND 12
QPSK EIRP POWER FOR LTE BAND 12 (1.4MHZ BANDWIDTH)

Test Results for Low Channel 699.7MHz							
Frequency(MHz)	SG Level(dBm)	Cable Loss(dB)	Antenna Factor(dB)	Absolute Level(dBm)	Limit (dBm)	Margin(dBm)	Polarity
1399.4	-49.98	2.60	27.20	-25.38	-13	-12.38	Horizontal
1399.4	-47.10	2.60	27.20	-22.50	-13	-9.50	Vertical
2099.1	-52.83	2.85	27.54	-28.14	-13	-15.14	Vertical
2099.1	-52.88	2.85	27.54	-28.19	-13	-15.19	Horizontal
176.8	-43.00	1.49	17.78	-26.71	-13	-13.71	Vertical
412.0	-36.40	1.36	17.33	-20.43	-13	-7.43	Horizontal
Test Results For Mid Channel 707.5MHz							
1415.0	-53.67	2.61	27.28	-29.00	-13	-16.00	Horizontal
1415.0	-49.11	2.61	27.28	-24.44	-13	-11.44	Vertical
2122.5	-53.85	2.87	27.59	-29.13	-13	-16.13	Vertical
2122.5	-52.17	2.87	27.59	-27.45	-13	-14.45	Horizontal
204.8	-34.23	1.73	15.74	-20.22	-13	-7.22	Vertical
445.3	-39.38	1.62	15.79	-25.21	-13	-12.21	Horizontal
Test Results for High Channel 715.3MHz							
1430.6	-44.76	2.63	27.28	-20.11	-13	-7.11	Horizontal
1430.6	-52.74	2.63	27.28	-28.09	-13	-15.09	Vertical
2145.9	-48.81	2.88	27.60	-24.09	-13	-11.09	Vertical
2145.9	-53.59	2.88	27.60	-28.87	-13	-15.87	Horizontal
193.5	-44.76	1.61	18.00	-28.37	-13	-15.37	Vertical
336.8	-41.81	1.45	15.49	-27.78	-13	-14.78	Horizontal

QPSK EIRP POWER FOR LTE BAND 12 (10MHZ BANDWIDTH)

Test Results for Low Channel 704MHz							
Frequency(MHz)	SG Level(dBm)	Cable Loss(dB)	Antenna Factor(dB)	Absolute Level(dBm)	Limit (dBm)	Margin(dBm)	Polarity
1408.0	-44.95	2.61	27.26	-20.30	-13	-7.30	Horizontal
1408.0	-52.17	2.61	27.26	-27.52	-13	-14.52	Vertical
2112.0	-44.53	2.87	27.58	-19.82	-13	-6.82	Vertical
2112.0	-50.39	2.87	27.58	-25.68	-13	-12.68	Horizontal
177.6	-44.44	1.31	16.97	-28.78	-13	-15.78	Vertical
441.9	-43.37	1.65	16.70	-28.32	-13	-15.32	Horizontal
Test Results for Mid Channel 707.5MHz							
1415.0	-52.28	2.61	27.28	-27.61	-13	-14.61	Horizontal
1415.0	-52.34	2.61	27.28	-27.67	-13	-14.67	Vertical
2122.5	-53.17	2.87	27.59	-28.45	-13	-15.45	Vertical
2122.5	-50.74	2.87	27.59	-26.02	-13	-13.02	Horizontal
212.2	-36.29	1.72	17.99	-20.02	-13	-7.02	Vertical
385.4	-41.42	1.73	17.94	-25.21	-13	-12.21	Horizontal
Test Results for High Channel 711MHz							
1422.0	-47.19	2.62	27.28	-22.53	-13	-9.53	Horizontal
1422.0	-48.72	2.62	27.28	-24.06	-13	-11.06	Vertical
2133.0	-46.96	2.87	27.60	-22.23	-13	-9.23	Vertical
2133.0	-50.75	2.87	27.60	-26.02	-13	-13.02	Horizontal
199.7	-44.86	1.58	15.93	-30.51	-13	-17.51	Vertical
256.2	-40.73	1.36	15.59	-26.50	-13	-13.50	Horizontal

Note: P_{Mea}(dBm)= Power(dBm)+ ARpl (dBm)

. Over Limit= : P_{Mea}(dBm)-Limit(dBm)

. Both QPSK and 16QAM has been tested, the worst case is QPSK mode, the report just reported the worst case.

9.6 LTE BAND 17

QPSK EIRP POWER FOR LTE BAND 17 (5MHZ BANDWIDTH)

Test Results for Low Channel 706.5MHz							
Frequency(MHz)	SG Level(dBm)	Cable Loss(dB)	Antenna Factor(dB)	Absolute Level(dBm)	Limit (dBm)	Margin(dBm)	Polarity
1413.0	-48.62	2.61	27.28	-23.95	-13	-10.95	Horizontal
1413.0	-49.97	2.61	27.28	-25.30	-13	-12.30	Vertical
2119.5	-53.53	2.87	27.59	-28.81	-13	-15.81	Vertical
2119.5	-52.79	2.87	27.59	-28.07	-13	-15.07	Horizontal
207.3	-38.12	1.71	16.15	-23.68	-13	-10.68	Vertical
385.2	-43.47	1.41	17.32	-27.56	-13	-14.56	Horizontal
Test Results For Mid Channel 710MHz							
1420.0	-46.46	2.62	27.30	-21.78	-13	-8.78	Horizontal
1420.0	-50.51	2.62	27.30	-25.83	-13	-12.83	Vertical
2130.0	-52.84	2.87	27.62	-28.09	-13	-15.09	Vertical
2130.0	-50.00	2.87	27.62	-25.25	-13	-12.25	Horizontal
180.6	-37.80	1.42	15.25	-23.98	-13	-10.98	Vertical
260.2	-43.57	1.36	17.19	-27.74	-13	-14.74	Horizontal
Test Results for High Channel 713.5MHz							
1427.0	-44.47	2.66	27.28	-19.85	-13	-6.85	Horizontal
1427.0	-49.30	2.66	27.28	-24.68	-13	-11.68	Vertical
2140.5	-47.26	2.88	27.60	-22.54	-13	-9.54	Vertical
2140.5	-51.60	2.88	27.60	-26.88	-13	-13.88	Horizontal
201.7	-40.17	1.32	17.29	-24.20	-13	-11.20	Vertical
358.6	-38.74	1.72	16.89	-23.57	-13	-10.57	Horizontal

QPSK EIRP POWER FOR LTE BAND 17 (10MHZ BANDWIDTH)

Test Results for Low Channel 709MHz							
Frequency(MHz)	SG Level(dBm)	Cable Loss(dB)	Antenna Factor(dB)	Absolute Level(dBm)	Limit (dBm)	Margin(dBm)	Polarity
1418.0	-51.12	2.62	27.30	-26.44	-13	-13.44	Horizontal
1418.0	-48.13	2.62	27.30	-23.45	-13	-10.45	Vertical
2127.0	-50.68	2.87	27.62	-25.93	-13	-12.93	Vertical
2127.0	-49.94	2.87	27.62	-25.19	-13	-12.19	Horizontal
212.0	-42.57	1.35	16.91	-27.01	-13	-14.01	Vertical
357.8	-39.87	1.62	16.31	-25.18	-13	-12.18	Horizontal
Test Results for Mid Channel 710MHz							
1420.0	-48.43	2.62	27.30	-23.75	-13	-10.75	Horizontal
1420.0	-45.50	2.62	27.30	-20.82	-13	-7.82	Vertical
2130.0	-46.50	2.87	27.62	-21.75	-13	-8.75	Vertical
2130.0	-50.58	2.87	27.62	-25.83	-13	-12.83	Horizontal
188.2	-40.24	1.51	17.14	-24.61	-13	-11.61	Vertical
362.8	-40.36	1.77	16.88	-25.25	-13	-12.25	Horizontal
Test Results for High Channel 711MHz							
1422.0	-46.33	2.62	27.30	-21.65	-13	-8.65	Horizontal
1422.0	-51.39	2.62	27.30	-26.71	-13	-13.71	Vertical
2133.0	-50.94	2.87	27.62	-26.19	-13	-13.19	Vertical
2133.0	-51.05	2.87	27.62	-26.30	-13	-13.30	Horizontal
210.8	-40.63	1.78	15.95	-26.46	-13	-13.46	Vertical
305.9	-35.36	1.34	17.95	-18.76	-13	-5.76	Horizontal

Note: Spurious Emission Level = Spectrum Analyzer Read Value + Cable Loss+ Antenna Factor + 11.74
 . Margin = Spurious Emission Level - Limit
 . Both QPSK and 16QAM has been tested, the worst case is QPSK mode, the report just reported the worst case.

9.7 LTE BAND 66

QPSK EIRP POWER FOR LTE BAND 66 (1.4MHZ BANDWIDTH)

Test Results for Low Channel 1710.7MHz							
Frequency(MHz)	SG Level(dBm)	Cable Loss(dB)	Antenna Factor(dB)	Absolute Level(dBm)	Limit (dBm)	Margin(dBm)	Polarity
3421.4	-49.83	4.02	29.80	-24.05	-13	-11.05	Horizontal
3421.4	-48.98	4.02	29.80	-23.20	-13	-10.20	Vertical
5132.1	-52.22	5.24	35.84	-21.62	-13	-8.62	Vertical
5132.1	-48.96	5.24	35.84	-18.36	-13	-5.36	Horizontal
112.6	-46.36	1.52	15.57	-32.31	-13	-19.31	Vertical
220.5	-44.98	1.33	17.14	-29.17	-13	-16.17	Horizontal
Test Results for Mid Channel 1745MHz							
3490.0	-48.40	4.03	30.00	-22.43	-13	-9.43	Horizontal
3490.0	-46.74	4.03	30.00	-20.77	-13	-7.77	Vertical
5235.0	-51.59	5.25	35.86	-20.98	-13	-7.98	Vertical
5235.0	-52.21	5.25	35.86	-21.60	-13	-8.60	Horizontal
157.3	-54.65	1.53	17.13	-39.05	-13	-26.05	Vertical
213.1	-45.38	1.41	15.95	-30.84	-13	-17.84	Horizontal
Test Results for High Channel 1779.3MHz							
3558.6	-53.17	4.05	30.01	-27.21	-13	-14.21	Horizontal
3558.6	-46.48	4.05	30.01	-20.52	-13	-7.52	Vertical
5337.9	-52.99	5.26	35.86	-22.39	-13	-9.39	Vertical
5337.9	-53.29	5.26	35.86	-22.69	-13	-9.69	Horizontal
170.6	-47.31	1.44	15.51	-33.24	-13	-20.24	Vertical
169.0	-44.57	1.78	15.76	-30.59	-13	-17.59	Horizontal

QPSK EIRP POWER FOR LTE BAND 66 (20MHZ BANDWIDTH)

Test Results for Low Channel 1720MHz							
Frequency(MHz)	SG Level(dBm)	Cable Loss(dB)	Antenna Factor(dB)	Absolute Level(dBm)	Limit (dBm)	Margin(dBm)	Polarity
3440.0	-48.29	4.02	29.80	-22.51	-13	-9.51	Horizontal
3440.0	-47.56	4.02	29.80	-21.78	-13	-8.78	Vertical
5160.0	-49.25	5.24	35.84	-18.65	-13	-5.65	Vertical
5160.0	-50.42	5.24	35.84	-19.82	-13	-6.82	Horizontal
268.8	-48.41	1.62	17.02	-33.01	-13	-20.01	Vertical
161.4	-53.84	1.32	17.31	-37.85	-13	-24.85	Horizontal
Test Results for Mid Channel 1745MHz							
3490.0	-44.07	4.03	30.00	-18.10	-13	-5.10	Horizontal
3490.0	-49.54	4.03	30.00	-23.57	-13	-10.57	Vertical
5235.0	-52.74	5.25	35.86	-22.13	-13	-9.13	Vertical
5235.0	-49.88	5.25	35.86	-19.27	-13	-6.27	Horizontal
159.9	-47.78	1.45	15.17	-34.06	-13	-21.06	Vertical
172.1	-47.20	1.48	17.82	-30.86	-13	-17.86	Horizontal
Test Results for High Channel 1770MHz							
3540.0	-52.53	2.91	27.68	-27.76	-13	-14.76	Horizontal
3540.0	-52.38	2.91	27.68	-27.61	-13	-14.61	Vertical
5310.0	-49.36	5.26	35.86	-18.76	-13	-5.76	Vertical
5310.0	-51.50	5.26	35.86	-20.90	-13	-7.90	Horizontal
197.3	-44.30	1.76	16.38	-29.68	-13	-16.68	Vertical
158.5	-52.42	1.43	17.13	-36.72	-13	-23.72	Horizontal

Note: $P_{Mea}(dBm) = Power(dBm) + ARpl(dBm)$

Over Limit = $P_{Mea}(dBm) - Limit(dBm)$

We test both H direction and V direction, recorded worst case direction.

Both QPSK and 16QAM has been tested, the worst case is QPSK mode, the report just reported the worst case.

10. FREQUENCY STABILITY

RULE PART(S)

FCC: §2.1055, §22.355, §24.235, §27.54,

LIMITS

§22.355 - The carrier frequency shall not depart from the reference frequency in excess of ± 2.5 ppm for mobile stations.

§24.235 - The frequency stability shall be sufficient to ensure that the fundamental emission stays within the authorized frequency block.

TEST PROCEDURE

Use CMW 500 with Frequency Error measurement capability.

- Temp. = -30° to $+50^{\circ}\text{C}$
- Voltage = low voltage, DC 3.4V, Normal, DC 3.87V and High voltage, DC 4.2V.

Frequency Stability vs Temperature:

The EUT is placed inside a temperature chamber. The temperature is set to -30°C and allowed to stabilize. After sufficient soak time, the transmitting frequency error is measured. The temperature is increased by 10 degrees, allowed to stabilize and soak, and then the measurement is repeated. This is repeated until $+50^{\circ}\text{C}$ is reached.

Frequency Stability vs Voltage:

The peak frequency error is recorded (worst-case).

MODES TESTED

LTE Band 2/4/5/7/12/17/66

RESULTS

See the following pages.

10.1 LTE BAND 2

Band 2 QPSK, (20MHz BANDWIDTH RB size 100 RB Offset 0)

Frequency error vs. Voltage

Voltage [Vdc]	Frequency [MHz]	Frequency* Error[Hz]	Frequency Error[ppm]	Limit [ppm]
3.40	1880	13.0	0.006935	2.5
3.87	1880	14.1	0.007519	2.5
4.20	1880	13.5	0.007163	2.5

Frequency error vs. Temperature

Temperature [°C]	Frequency [MHz]	Frequency* Error[Hz]	Frequency Error[ppm]	Limit [ppm]
Normal (25C)	1880	13.1	0.006944	2.5
Extreme (50C)	1880	11.6	0.006190	2.5
Extreme (40C)	1880	14.2	0.007552	2.5
Extreme (30C)	1880	13.6	0.007236	2.5
Extreme (10C)	1880	13.5	0.007204	2.5
Extreme (0C)	1880	12.2	0.006488	2.5
Extreme (-10C)	1880	12.9	0.006846	2.5
Extreme (-20C)	1880	13.6	0.007251	2.5
Extreme (-30C)	1880	14.9	0.007912	2.5

Band 2 16QAM, (20MHz BANDWIDTH RB size 100 RB Offset 0)

Frequency error vs. Voltage

Voltage [Vdc]	Frequency [MHz]	Frequency* Error[Hz]	Frequency Error[ppm]	Limit [ppm]
3.40	1880	10.0	0.005299	2.5
3.87	1880	9.2	0.004918	2.5
4.20	1880	8.3	0.004419	2.5

Frequency error vs. Temperature

Temperature [°C]	Frequency [MHz]	Frequency* Error[Hz]	Frequency Error[ppm]	Limit [ppm]
Normal (25C)	1880	9.3	0.004936	2.5
Extreme (50C)	1880	9.3	0.004964	2.5
Extreme (40C)	1880	8.0	0.004246	2.5
Extreme (30C)	1880	9.1	0.004838	2.5
Extreme (10C)	1880	8.9	0.004730	2.5
Extreme (0C)	1880	8.0	0.004261	2.5
Extreme (-10C)	1880	9.3	0.004925	2.5
Extreme (-20C)	1880	8.8	0.004692	2.5
Extreme (-30C)	1880	8.1	0.004320	2.5

***Note:** Frequency error measurements were made by using the build-in capability of the Wireless Communication Test Set.

10.2 LTE BAND 4

Band 4 QPSK, (20MHz BANDWIDTH RB size 100 RB Offset 0)
Frequency error vs. Voltage

Voltage [Vdc]	Frequency [MHz]	Frequency* Error[Hz]	Frequency Error[ppm]	Limit [ppm]
3.40	1732.5	8.8	0.005061	2.5
3.87	1732.5	8.9	0.005162	2.5
4.20	1732.5	8.4	0.004837	2.5

Frequency error vs. Temperature

Temperature [°C]	Frequency [MHz]	Frequency* Error[Hz]	Frequency Error[ppm]	Limit [ppm]
Normal (25C)	1732.5	8.3	0.004777	2.5
Extreme (50C)	1732.5	8.8	0.005106	2.5
Extreme (40C)	1732.5	7.5	0.004323	2.5
Extreme (30C)	1732.5	6.2	0.003605	2.5
Extreme (10C)	1732.5	7.1	0.004103	2.5
Extreme (0C)	1732.5	9.2	0.005301	2.5
Extreme (-10C)	1732.5	8.0	0.004621	2.5
Extreme (-20C)	1732.5	7.0	0.004050	2.5
Extreme (-30C)	1732.5	8.7	0.005021	2.5

Band 4 16QAM, (20MHz BANDWIDTH RB size 100 RB Offset 0)

Frequency error vs. Voltage

Voltage [Vdc]	Frequency [MHz]	Frequency* Error[Hz]	Frequency Error[ppm]	Limit [ppm]
3.40	1732.5	10.1	0.005822	2.5
3.87	1732.5	9.3	0.005393	2.5
4.20	1732.5	7.7	0.004455	2.5

Frequency error vs. Temperature

Temperature [°C]	Frequency [MHz]	Frequency* Error[Hz]	Frequency Error[ppm]	Limit [ppm]
Normal (25C)	1732.5	9.4	0.005446	2.5
Extreme (50C)	1732.5	8.5	0.004887	2.5
Extreme (40C)	1732.5	8.5	0.004904	2.5
Extreme (30C)	1732.5	9.2	0.005316	2.5
Extreme (10C)	1732.5	8.9	0.005147	2.5
Extreme (0C)	1732.5	7.9	0.004569	2.5
Extreme (-10C)	1732.5	9.2	0.005327	2.5
Extreme (-20C)	1732.5	9.0	0.005183	2.5
Extreme (-30C)	1732.5	8.1	0.004675	2.5

***Note:** Frequency error measurements were made by using the build-in capability of the Wireless Communication Test Set.

10.3 LTE BAND 5

Band 5 QPSK, (10MHz BANDWIDTH RB size 50 RB Offset 0)

Frequency error vs. Voltage

Voltage [Vdc]	Frequency [MHz]	Frequency* Error[Hz]	Frequency Error[ppm]	Limit [ppm]
3.40	836.5	5.9	0.007105	2.5
3.87	836.5	7.1	0.008498	2.5
4.20	836.5	5.1	0.006115	2.5

Frequency error vs. Temperature

Temperature [°C]	Frequency [MHz]	Frequency* Error[Hz]	Frequency Error[ppm]	Limit [ppm]
Normal (25C)	836.5	6.0	0.007213	2.5
Extreme (50C)	836.5	5.7	0.006763	2.5
Extreme (40C)	836.5	6.6	0.007881	2.5
Extreme (30C)	836.5	6.7	0.008034	2.5
Extreme (10C)	836.5	5.3	0.006380	2.5
Extreme (0C)	836.5	4.8	0.005760	2.5
Extreme (-10C)	836.5	5.4	0.006475	2.5
Extreme (-20C)	836.5	6.4	0.007627	2.5
Extreme (-30C)	836.5	6.0	0.007190	2.5

Band 5 16QAM, (10MHz BANDWIDTH RB size 50 RB Offset 0)

Frequency error vs. Voltage

Voltage [Vdc]	Frequency [MHz]	Frequency* Error[Hz]	Frequency Error[ppm]	Limit [ppm]
3.40	836.5	5.9	0.007062	2.5
3.87	836.5	6.4	0.007618	2.5
4.20	836.5	5.2	0.006209	2.5

Frequency error vs. Temperature

Temperature [°C]	Frequency [MHz]	Frequency* Error[Hz]	Frequency Error[ppm]	Limit [ppm]
Normal (25C)	836.5	6.3	0.007585	2.5
Extreme (50C)	836.5	5.9	0.007035	2.5
Extreme (40C)	836.5	6.0	0.007198	2.5
Extreme (30C)	836.5	6.2	0.007365	2.5
Extreme (10C)	836.5	5.8	0.006908	2.5
Extreme (0C)	836.5	5.2	0.006271	2.5
Extreme (-10C)	836.5	5.8	0.006967	2.5
Extreme (-20C)	836.5	6.4	0.007701	2.5
Extreme (-30C)	836.5	6.4	0.007701	2.5

***Note:** Frequency error measurements were made by using the build-in capability of the Wireless Communication Test Set.

10.4 LTE BAND 7

Band 7 QPSK, (20MHz BANDWIDTH RB size 100 RB Offset 0)

Frequency error vs. Voltage

Voltage [Vdc]	Frequency [MHz]	Frequency* Error[Hz]	Frequency Error[ppm]	Limit [ppm]
3.40	2535	10.0	0.003947	2.5
3.87	2535	8.4	0.003331	2.5
4.20	2535	8.6	0.003408	2.5

Frequency error vs. Temperature

Temperature [°C]	Frequency [MHz]	Frequency* Error[Hz]	Frequency Error[ppm]	Limit [ppm]
Normal (25C)	2535	9.8	0.003853	2.5
Extreme (50C)	2535	9.3	0.003677	2.5
Extreme (40C)	2535	8.1	0.003214	2.5
Extreme (30C)	2535	8.5	0.003354	2.5
Extreme (10C)	2535	7.9	0.003130	2.5
Extreme (0C)	2535	8.6	0.003399	2.5
Extreme (-10C)	2535	9.7	0.003837	2.5
Extreme (-20C)	2535	9.1	0.003594	2.5
Extreme (-30C)	2535	7.9	0.003121	2.5

Band 7 16QAM, (20MHz BANDWIDTH RB size 100 RB Offset 0)

Frequency error vs. Voltage

Voltage [Vdc]	Frequency [MHz]	Frequency* Error[Hz]	Frequency Error[ppm]	Limit [ppm]
3.40	2535	7.1	0.002786	2.5
3.87	2535	6.1	0.002407	2.5
4.20	2535	5.2	0.002063	2.5

Frequency error vs. Temperature

Temperature [°C]	Frequency [MHz]	Frequency* Error[Hz]	Frequency Error[ppm]	Limit [ppm]
Normal (25C)	2535	6.7	0.002628	2.5
Extreme (50C)	2535	5.8	0.002292	2.5
Extreme (40C)	2535	5.5	0.002182	2.5
Extreme (30C)	2535	6.5	0.002567	2.5
Extreme (10C)	2535	5.3	0.002085	2.5
Extreme (0C)	2535	5.0	0.001966	2.5
Extreme (-10C)	2535	4.8	0.001878	2.5
Extreme (-20C)	2535	5.4	0.002148	2.5
Extreme (-30C)	2535	6.0	0.002383	2.5

***Note:** Frequency error measurements were made by using the build-in capability of the Wireless Communication Test Set.

10.5 LTE BAND 12

Band 12 QPSK, (10MHz BANDWIDTH RB size 50 RB Offset 0

Frequency error vs. Voltage

Voltage [Vdc]	Frequency [MHz]	Frequency* Error[Hz]	Frequency Error[ppm]	Limit [ppm]
3.40	707.5	8.5	0.012017	2.5
3.87	707.5	9.9	0.014034	2.5
4.20	707.5	9.1	0.012826	2.5

Frequency error vs. Temperature

Temperature [°C]	Frequency [MHz]	Frequency* Error[Hz]	Frequency Error[ppm]	Limit [ppm]
Normal (25C)	707.5	8.8	0.012412	2.5
Extreme (50C)	707.5	7.3	0.010382	2.5
Extreme (40C)	707.5	7.6	0.010774	2.5
Extreme (30C)	707.5	8.1	0.011500	2.5
Extreme (10C)	707.5	7.7	0.010815	2.5
Extreme (0C)	707.5	8.5	0.012048	2.5
Extreme (-10C)	707.5	8.5	0.012065	2.5
Extreme (-20C)	707.5	9.4	0.013280	2.5
Extreme (-30C)	707.5	7.4	0.010393	2.5

Band 12 16QAM, (10MHz BANDWIDTH RB size 50 RB Offset 0)

Frequency error vs. Voltage

Voltage [Vdc]	Frequency [MHz]	Frequency* Error[Hz]	Frequency Error[ppm]	Limit [ppm]
3.40	707.5	7.7	0.010923	2.5
3.87	707.5	8.8	0.012416	2.5
4.20	707.5	7.6	0.010700	2.5

Frequency error vs. Temperature

Temperature [°C]	Frequency [MHz]	Frequency* Error[Hz]	Frequency Error[ppm]	Limit [ppm]
Normal (25C)	707.5	6.5	0.009175	2.5
Extreme (50C)	707.5	5.5	0.007765	2.5
Extreme (40C)	707.5	6.4	0.009110	2.5
Extreme (30C)	707.5	-7.7	-0.010912	2.5
Extreme (10C)	707.5	-8.2	-0.011590	2.5
Extreme (0C)	707.5	2.9	0.004100	2.5
Extreme (-10C)	707.5	-5.2	-0.007292	2.5
Extreme (-20C)	707.5	-8.7	-0.012302	2.5
Extreme (-30C)	707.5	-10.2	-0.014350	2.5

***Note:** Frequency error measurements were made by using the build-in capability of the Wireless Communication Test Set.

10.6 LTE BAND 17

Band 17 QPSK, (10MHz BANDWIDTH RB size 50 RB Offset 0)

Frequency error vs. Voltage

Voltage [Vdc]	Frequency [MHz]	Frequency* Error[Hz]	Frequency Error[ppm]	Limit [ppm]
3.40	710.0	9.7	0.013662	2.5
3.87	710.0	9.3	0.013091	2.5
4.20	710.0	7.9	0.011083	2.5

Frequency error vs. Temperature

Temperature [°C]	Frequency [MHz]	Frequency* Error[Hz]	Frequency Error[ppm]	Limit [ppm]
Normal (25C)	710.0	9.8	0.013844	2.5
Extreme (50C)	710.0	9.1	0.012831	2.5
Extreme (40C)	710.0	7.9	0.011147	2.5
Extreme (30C)	710.0	8.5	0.012019	2.5
Extreme (10C)	710.0	8.9	0.012546	2.5
Extreme (0C)	710.0	8.4	0.011806	2.5
Extreme (-10C)	710.0	9.0	0.012660	2.5
Extreme (-20C)	710.0	8.5	0.011919	2.5
Extreme (-30C)	710.0	8.2	0.011484	2.5

Band 17 16QAM, (10MHz BANDWIDTH RB size 50 RB Offset 0)

Frequency error vs. Voltage

Voltage [Vdc]	Frequency [MHz]	Frequency* Error[Hz]	Frequency Error[ppm]	Limit [ppm]
3.40	710.0	10.0	0.014093	2.5
3.87	710.0	8.5	0.012015	2.5
4.20	710.0	8.4	0.011867	2.5

Frequency error vs. Temperature

Temperature [°C]	Frequency [MHz]	Frequency* Error[Hz]	Frequency Error[ppm]	Limit [ppm]
Normal (25C)	710.0	9.6	0.013542	2.5
Extreme (50C)	710.0	8.5	0.011914	2.5
Extreme (40C)	710.0	8.1	0.011426	2.5
Extreme (30C)	710.0	9.3	0.013048	2.5
Extreme (10C)	710.0	8.1	0.011374	2.5
Extreme (0C)	710.0	8.8	0.012425	2.5
Extreme (-10C)	710.0	9.4	0.013292	2.5
Extreme (-20C)	710.0	8.7	0.012291	2.5
Extreme (-30C)	710.0	7.9	0.011146	2.5

***Note:** Frequency error measurements were made by using the build-in capability of the Wireless Communication Test Set.

10.7 LTE BAND 66

QPSK, (20MHz BANDWIDTH)

Frequency error vs. Voltage

Voltage [Vdc]	Frequency [MHz]	Frequency* Error[Hz]	Frequency Error[ppm]	Limit [ppm]
BAND 66 QPSK, (CH 132322 RB size 100 RB Offset 0 20MHz BANDWIDTH)				
3.40	1745	7.4	0.003915	2.5
3.87	1745	7.1	0.003812	2.5
4.20	1745	8.0	0.004172	2.5

Frequency error vs. Temperature

Temperature [°C]	Frequency [MHz]	Frequency* Error[Hz]	Frequency Error[ppm]	Limit [ppm]
BAND 66 QPSK, (CH 132322 RB size 100 RB Offset 0 20MHz BANDWIDTH)				
Normal (25C)	1745	6.1	0.002985	2.5
Extreme (50C)	1745	8.3	0.004317	2.5
Extreme (40C)	1745	6.8	0.003454	2.5
Extreme (30C)	1745	7.4	0.003974	2.5
Extreme (10C)	1745	8.8	0.004509	2.5
Extreme (0C)	1745	6.0	0.003463	2.5
Extreme (-10C)	1745	6.1	0.003313	2.5
Extreme (-20C)	1745	7.0	0.003852	2.5
Extreme (-30C)	1745	6.9	0.003423	2.5

16QAM, (20MHz BANDWIDTH)

Frequency error vs. Voltage

Voltage [Vdc]	Frequency [MHz]	Frequency* Error[Hz]	Frequency Error[ppm]	Limit [ppm]
BAND 66 16QAM, (CH 132322 RB size 100 RB Offset 0 20MHz BANDWIDTH)				
3.40	1745	8.3	0.004620	2.5
3.87	1745	8.3	0.004436	2.5
4.20	1745	9.2	0.005194	2.5

Frequency error vs. Temperature

Temperature [°C]	Frequency [MHz]	Frequency* Error[Hz]	Frequency Error[ppm]	Limit [ppm]
BAND 66 16QAM, (CH 132322 RB size 100 RB Offset 0 20MHz BANDWIDTH)				
Normal (25C)	1745	9.6	0.005061	2.5
Extreme (50C)	1745	8.0	0.004447	2.5
Extreme (40C)	1745	8.6	0.004757	2.5
Extreme (30C)	1745	8.3	0.004539	2.5
Extreme (10C)	1745	8.9	0.004636	2.5
Extreme (0C)	1745	7.1	0.003824	2.5
Extreme (-10C)	1745	8.7	0.004745	2.5
Extreme (-20C)	1745	9.1	0.004918	2.5
Extreme (-30C)	1745	6.1	0.003037	2.5

***Note:** Frequency error measurements were made by using the build-in capability of the Wireless Communication Test Set.

11. Peak-to-Average Ratio

11.1 Description of the PAR Measurement

The peak-to-average ratio (PAR) of the transmission may not exceed 13 dB.

11.2 Measuring Instruments

See list of measuring instruments of this test report.

11.3 Test Procedures

1. The EUT was connected to Spectrum Analyzer and Base Station via power divider.
2. The RF output of EUT was connected to the spectrum analyzer by RF cable and attenuator. The path loss was compensated to the results for each measurement.
3. For LTE operating modes:
 - a. Set the CCDF (Complementary Cumulative Distribution Function) option in spectrum analyzer.
 - b. The highest RF powers were measured and recorded the maximum PAPR level associated with a probability of 0.1 %.

11.4 Test Setup

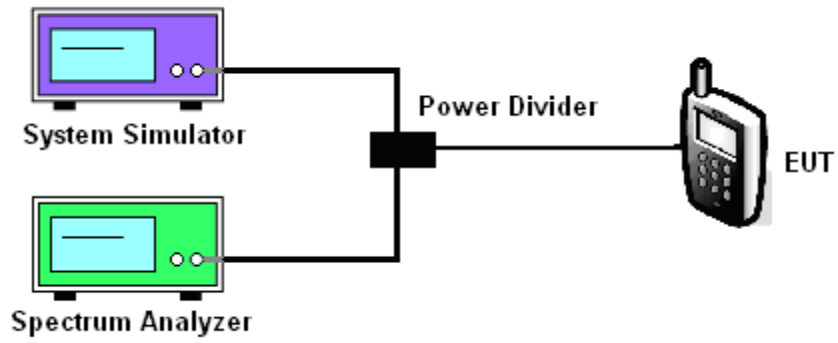

MODES TESTED

LTE Band 2/4/5/7/12/17/66

Test data reference attachment.

----END OF REPORT----