

## RF Test Report

Applicant : PEAG, LLC dba JLab Audio  
Product Type : Speaker with bluetooth  
Model Number : CRASHER SLIM Speaker  
FCC ID : 2AHYVCRSHSLIM  
EUT Rated Voltage : DC 5V, 3.7A  
Test Voltage : 120 Vac / 60 Hz  
Receive Date : Jan. 12 , 2018  
Test Period : Jan 15 ~ Jan. 31 , 2018  
Issued Date : May 16, 2018  
Applicable Standards : FCC 47 CFR PART 15 SUBPART C  
ANSI C63.10:2013  
Test Result : Complied

### Testing Laboratory

#### A Test Lab Techno Corp.

101-104, 1F, A building, Safflower ridge industrial area,  
Taoyuan street, Nanshan district, Shenzhen

Tel : +86-755-23987770 / Fax : +86-755-26637771

American Association for Laboratory Accreditation number: 3464.02



**Note:** This report shall not be reproduced except in full, without the written approval of A Test Lab Techno Corp. This document may be altered or revised by A Test Lab Techno Corp. personnel only and shall be noted in the revision section of the document. The client should not use it to claim product endorsement by A2LA, or any government agencies. The test results in the report only apply to the tested sample.

Approved By : Hai Wang Reviewed By : Mick Zhang  
(Manager) (Hai. Wang) (Testing Engineer) (Mick. Zhang)

**Revision History**

Rev.	Issue Date	Revisions	Revised by
00	Feb. 06, 2018	Initial Issue	Yao Zhang
01	May 16, 2018	Revised report information.	Willa Lan

## TABLE OF CONTENTS

<b>1</b>	<b>General Information .....</b>	<b>4</b>
	1.1. Summary of Test Result.....	4
	1.2. Measurement Uncertainty.....	5
<b>2</b>	<b>EUT Description .....</b>	<b>6</b>
<b>3</b>	<b>Test Methodology.....</b>	<b>7</b>
	3.1. Mode of Operation.....	7
	3.2. EUT Exercise Software.....	7
	3.3. Configuration of Test System Details .....	8
	3.4. Test Instruments .....	9
	3.5. Test Site Environment.....	10
<b>4</b>	<b>Measurement Procedure.....</b>	<b>11</b>
	4.1. AC Power Line Conducted Emission Measurement.....	11
	4.2. Radiated Interference Measurement.....	13
	4.3. Maximum Conducted Output Power Measurement.....	17
	4.4. 20dB RF Bandwidth Measurement .....	18
	4.5. Carrier Frequency Separation Measurement .....	19
	4.6. Number of Hopping Measurement.....	20
	4.7. Time of Occupancy (Dwell Time) Measurement.....	21
	4.8. Out of Band Conducted Emissions Measurement.....	22
	4.9. Antenna Measurement .....	23
<b>5</b>	<b>Test Results.....</b>	<b>24</b>
	Annex A. Conducted Emission .....	24
	Annex B. Conducted Test Results.....	26
	Annex C. Radiated Emission Measurement.....	43

# 1 General Information

## 1.1. Summary of Test Result

FCC Standard	Item	Result	Remark
15.207	AC Power Conducted Emission	PASS	-----
15.203	Antenna Requirement	PASS	-----
15.247(b)(1)	Max. Output Power	PASS	-----
15.247(d)	Transmitter Radiated Emissions	PASS	-----
15.247(a)(1)	20dB RF Bandwidth	PASS	-----
15.247(a)(1)	Carrier Frequency Separation	PASS	-----
15.247(a)(1)(iii)	Number of Hopping	PASS	-----
15.247(a)(1)(iii)	Time of Occupancy (Dwell Time)	PASS	-----
15.247(d)	Out of Band Conducted Spurious Emission	PASS	-----

Standard	Description
CFR47, Part 15, Subpart C §15.247	Intentional Radiators
ANSI C63. 10: 2013	American National Standard of Procedures for Compliance Testing of Unlicensed Wireless Devices
ANSI C63. 4: 2014	American National Standard for methods of measurement of radio – noise emissions from low-voltage electrical and electronic equipment in the range of 9 kHz to 40 GHz
KDB 558074 D01 v04	Guidance For Performing Compliance Measurements On Digital Transmission Systems (DTS) Operating Under Section 15.247
Standard IC	Description
RSS-247 ISSUE 2: Feb., 2017	Digital Transmission Systems (DTSs), Frequency Hopping Systems (FHSs) and Licence - Exempt Local Area Network (LE- LAN) Devices
RSS-Gen ISSUE 4: Nov., 2014	Spectrum Management and Telecommunications Radio Standards Specification - General Requirements and Information for the Certification of Radio Apparatus

The test results of this report relate only to the tested sample(s) identified in this report. Manufacturer or whom it may concern should recognize the pass or fail of the test result.

A Test Lab Techno Corp. tested the above equipment under the requirements outlined in the above standards. All indications of Pass/Fail in this report are opinions expressed by A Test Lab Techno Corp. Based on interpretations and/or observations of test results. Measurement Uncertainties were not taken into account and are published for informational purposes only. The test results show that the equipment tested is capable of demonstrating compliance with the requirements as documented in this report.

A Test Lab Techno Corp. will not be liable for any loss or damage resulting from false, inaccurate, inappropriate or incomplete product information provided by the customer.

This test report is electronically signed and valid without handwriting signature. For verification of the electronic signatures, the public keys can be requested at the testing laboratory.

## 1.2. Measurement Uncertainty

Test Item	Frequency Range	Uncertainty (dB)
Conducted Emission	9kHz ~ 150KHz	2.6
	150kHz ~ 30MHz	2.6
Radiated Emission	30MHz ~ 1000MHz	5.6
	1000MHz ~ 18000MHz	5.5
	18000MHz ~ 26500MHz	4.9
	26500MHz ~ 40000MHz	4.9
Conducted Output Power	+0.26 dB / -0.29 dB	
RF Bandwidth	4.95%	
Power Spectral Density	+0.72 dB / -0.78 dB	

## 2 EUT Description

Applicant	PEAG, LLC dba JLab Audio 2281 Las Palmas Drive,Suite 101 Carlsbad, CA 92011	
Manufacturer	Musilab Electronic (DongGuan) Co., Ltd No.5 Huanwei Street,Fugang,Qingxi Town, Dongguan,Guangdong,China	
Product	Speaker with bluetooth	
Model Number	CRASHER SLIM Speaker	
FCC ID	2AHYVCRSHSLIM	
Frequency Range	2402 ~ 2480 MHz	
Modulation Type	GFSK for 1Mbps	
	$\pi/4$ -DQPSK for 2Mbps	
	8DPSK for 3Mbps	
Operate Temp. Range	-20 ~ 50°C	
Antenna information	Type	Max. Gain (dBi)
	PCB Antenna	
RF Output Power	GFSK for 1Mbps	0.00061 W
(Conducted)	$\pi/4$ -DQPSK for 2Mbps	0.00130 W
	8DPSK for 3Mbps	0.00141 W

### 3 Test Methodology

#### 3.1. Mode of Operation

Decision of Test ATL has verified the construction and function in typical operation. All the test modes were carried out with the EUT in normal operation, which was shown in this test report and defined as:

Pre-Test Mode
Mode 1: Transmit mode
Mode 2: GFSK Continuous TX mode
Mode 3: $\pi/4$ -DQPSK Continuous TX mode
Mode 4: 8DPSK Continuous TX mode

After verification, all tests were carried out with the worst case test modes as shown below except radiated spurious emission below 1GHz and power line conducted emissions below 30MHz, which worst case was in TX mode only.

By preliminary testing and verifying three axis (X, Y and Z) position of EUT transmitted status, it was found that "X axis" position was the worst, then the final test was executed the worst condition and test data were recorded in this report.

Final-Test Mode
Mode 1: Transmit mode
Mode 2: GFSK Continuous TX mode
Mode 4: 8DPSK Continuous TX mode

#### Description of Test Modes

Preliminary tests were performed in different modulation to find the worst case. The modulation has shown the worst-case in section 4.5. Investigation has been done on all the possible configurations for searching the worst cases.

#### 3.2. EUT Exercise Software

1	Setup the EUT shown on "Configuration of Test System Details".
2	Turn on the power of all equipment.
3	Turn on TX function
4	EUT run test program.

Measurement Software	
1	EZ-EMC Ver. ATL-03A1-1
2	EZ-EMC Ver ATL-ITC-3A1-1

### 3.3. Configuration of Test System Details

Conducted Emission

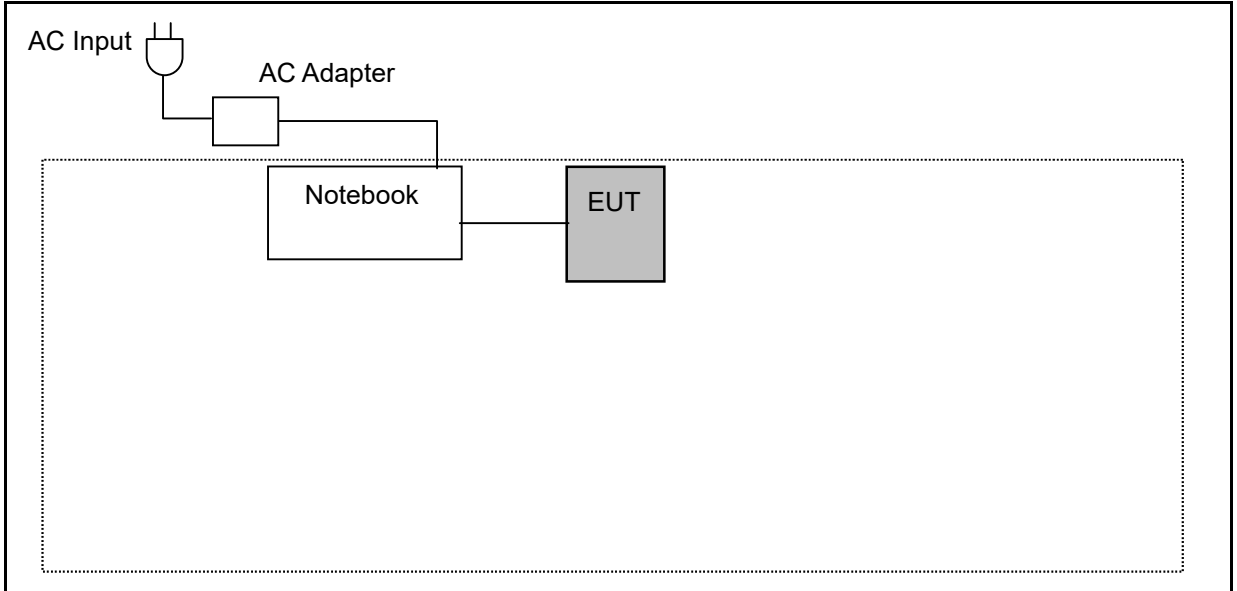

Radiated Emissions

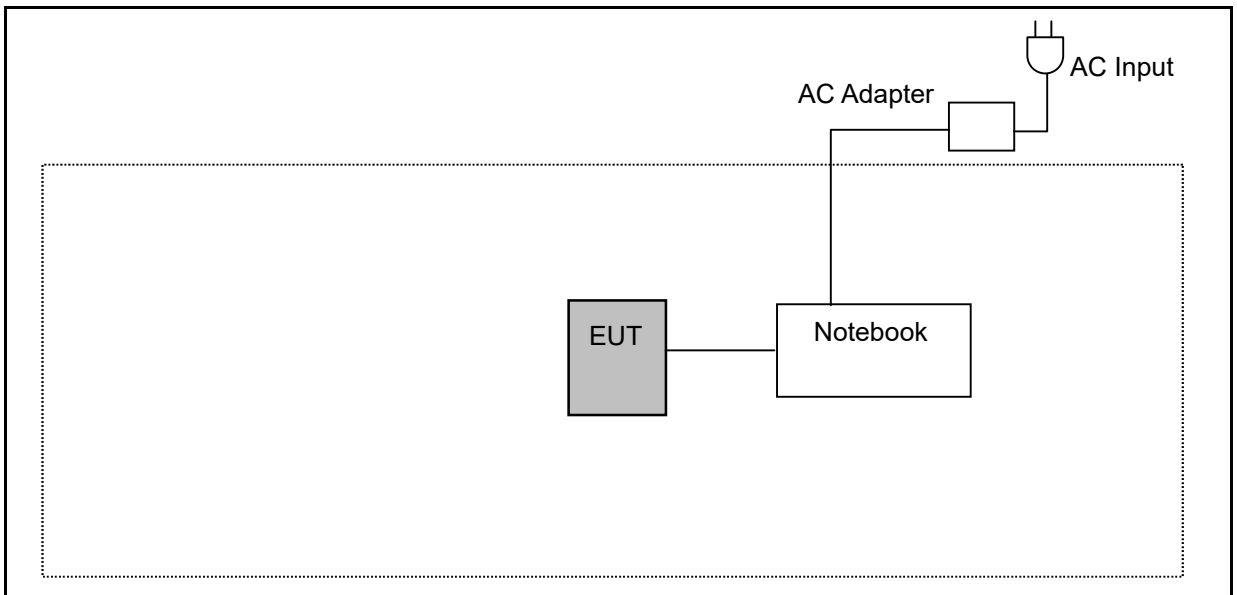



### 3.4. Test Instruments

For Conducted Emission

Equipment	Manufacturer	Model Number	Serial Number	Cal. Date	Cal. Period
Test Receiver	R&S	ESR3	101923	09/19/2017	1 year
LISN	R&S	ENV216	101942	09/19/2017	1 year
LISN	R&S	ENV216	101943	09/19/2017	1 year
RF Cable	EMCI	EMCCFD400	433LFC	09/19/2017	1 year
Test Site	ATL	CE	CE	N.C.R.	----

For Radiated Emissions\_966A

Equipment	Manufacturer	Model Number	Serial Number	Cal. Date	Remark
Preamplifier (10kHz~3GHz)	EMCI	EMC001330	980300	09/19/2017	1 year
Preamplifier (0.1GHz~26.5GHz)	EMCI	EMC012645SE	980318	09/19/2017	1 year
Preamplifier (26.5GHz~40GHz)	EMCI	EMC2654045	980028	08/29/2017	1 year
Bilog Antenna (30MHz~1.4GHz)	Schwarzbeck	VULB 9168	672	11/15/2017	1 year
Horn Antenna (1GHz~18GHz)	ETS	3117	00204949	11/15/2017	1 year
Horn Antenna (18GHz~26.5GHz)	ETS	3160-09	00202549	11/15/2017	1 year
Horn Antenna (18GHz~40GHz)	ETS	3116	00086467	09/19/2017	1 year
Receiver (3Hz~26.5GHz)	Keysight	N9038A	MY51210179	09/19/2017	1 year
Spectrum Analyzer (3Hz~43GHz)	Keysight	N9030A	MY55410268	09/19/2017	1 year
Cable (30MHz~1GHz)	EMCI	N/A	1066LFC	09/19/2017	1 year
Cable (1GHz~18GHz)	EMCI	N/A	160719	09/19/2017	1 year
Cable (1GHz~18GHz)	EMCI	N/A	160324	09/19/2017	1 year
Cable (1GHz~18GHz)	EMCI	N/A	160322	09/19/2017	1 year
Test Site	ATL	MFAC3M	RE-026	08/29/2017	1 year

Note: N.C.R. = No Calibration Request.

For Conducted

Equipment	Manufacturer	Model Number	Serial Number	Cal. Date	Remark
Power Sensor	Anritsu	U2021XA	SG54130003	09/19/2017	1 year
Spectrum Analyzer (10Hz~26.5GHz)	Agilent	N9020A	MY53420615	09/19/2017	1 year
Spectrum Analyzer (9KHz~26.5GHz)	Agilent	E4445A	MY46181814	09/19/2017	1 year
Programmable temp & humi chamber	ETAI	9712A	647	09/19/2017	1 year
Test Site	ATL	RF	RF	N.C.R.	-----

Note: N.C.R. = No Calibration Request.

### 3.5. Test Site Environment

Items	Required (IEC 60068-1)	Actual
Temperature (°C)	15-35	26
Humidity (%RH)	25-75	60
Barometric pressure (mbar)	860-1060	950

## 4 Measurement Procedure

### 4.1. AC Power Line Conducted Emission Measurement

■ Limit

Frequency (MHz)	Quasi-peak	Average
0.15 - 0.5	66 to 56	56 to 46
0.50 - 5.0	56	46
5.0 - 30.0	60	50

■ Test Setup

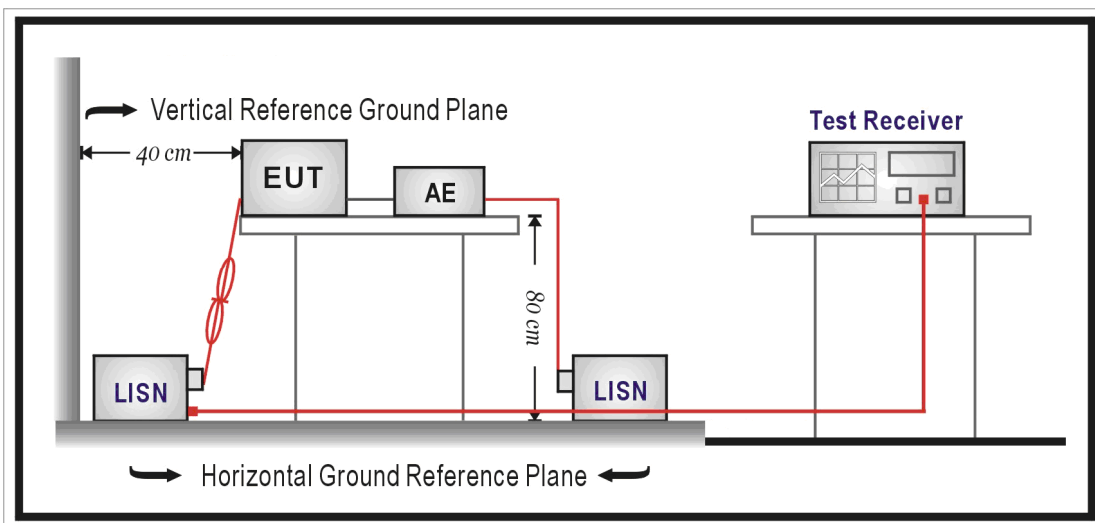

## ■ Test Procedure

The EUT and simulators are connected to the main power through a line impedance stabilization network (L.I.S.N.). This provides a  $50\ \Omega // 50\ \mu\text{H}$  coupling impedance for the measuring equipment. The peripheral devices are also connected to the main power through a LISN that provides a  $50\ \Omega // 50\ \mu\text{H}$  coupling impedance with 50ohm termination.

Tabletop device shall be placed on a non-conducting platform, of nominal size 1 m by 1.5 m, raised 80 cm above the reference ground plane. The wall of screened room shall be located 40cm to the rear of the EUT. Other surfaces of tabletop or floor standing EUT shall be at least 80cm from any other ground conducting surface including one or more LISNs. For floor-standing device shall be placed under the EUT with a 12mm insulating material.

Conducted emissions were investigated over the frequency range from 0.15 MHz to 30 MHz using a resolution bandwidth of 9 kHz. The equipment under test (EUT) shall be meet the limits in section 4.1, as applicable, including the average limit and the quasi-peak limit when using respectively, an average detector and quasi-peak detector measured in accordance with the methods described of related standard. When all of peak value were complied with quasi-peak and average limit from 150kHz to 30MHz then quasi-peak and average measurement was unnecessary.

The AMN shall be placed 0,8 m from the boundary of the unit under test and bonded to a ground reference plane for AMNs mounted on top of the ground reference plane. This distance is between the closest points of the AMN and the EUT. All other units of the EUT and associated equipment shall be at least 0,8 m from the AMN. If the mains power cable is longer than 1m then the cable shall be folded back and forth at the centre of the lead to form a bundle no longer than 0.4m. All of interconnecting cables that hang closer than 40cm to the ground plane shall be folded back and forth in the center forming a bundle 30 cm to 40 cm long. All of EUT and AE shall be separate place more than 0.1m. All  $50\ \Omega$  ports of the LISN shall be resistively terminated into  $50\ \Omega$  loads when not connected to the measuring instrument.

If the reading of the measuring receiver shows fluctuations close to the limit, the reading shall be observed for at least 15 s at each measurement frequency; the higher reading shall be recorded with the exception of any brief isolated high reading which shall be ignored.

## 4.2. Radiated Interference Measurement

### ■ Limit

According to §15.209(a), except as provided elsewhere in this subpart, the emissions from an intentional radiator shall not exceed the field strength levels specified in the following table:

Frequency (MHz)	Field Strength ( $\mu\text{V}/\text{m}$ at meter)	Measurement Distance (meters)
0.009 – 0.490	2400 / F (kHz)	300
0.490 – 1.705	24000 / F (kHz)	30
1.705 – 30.0	30	30
30 - 88	100**	3
88-216	150**	3
216-960	200**	3
Above 960	500	3

\*\* Except as provided in paragraph (g), fundamental emissions from intentional radiators operating under this Section shall not be located in the frequency bands 54-72 MHz, 76-88 MHz, 174-216 MHz or 470-806 MHz. However, operation within these frequency bands is permitted under other sections of this Part, e.g., Sections 15.231 and 15.241.

■ Setup

9kHz ~ 30MHz

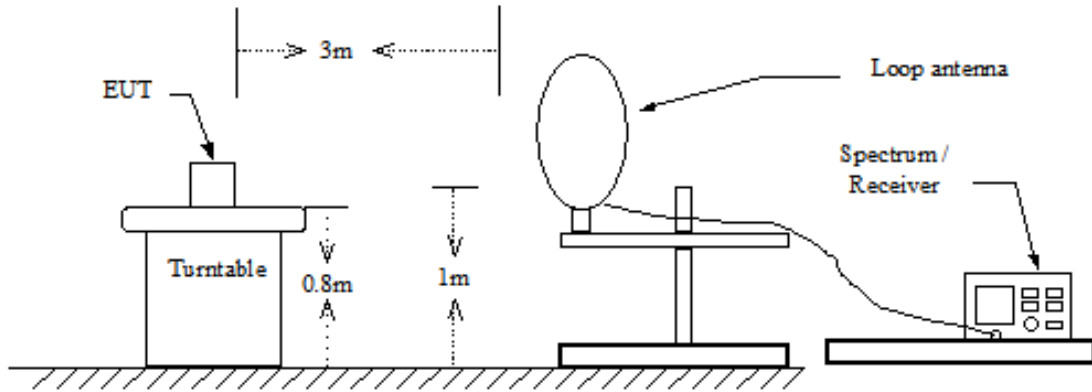

Below 1GHz

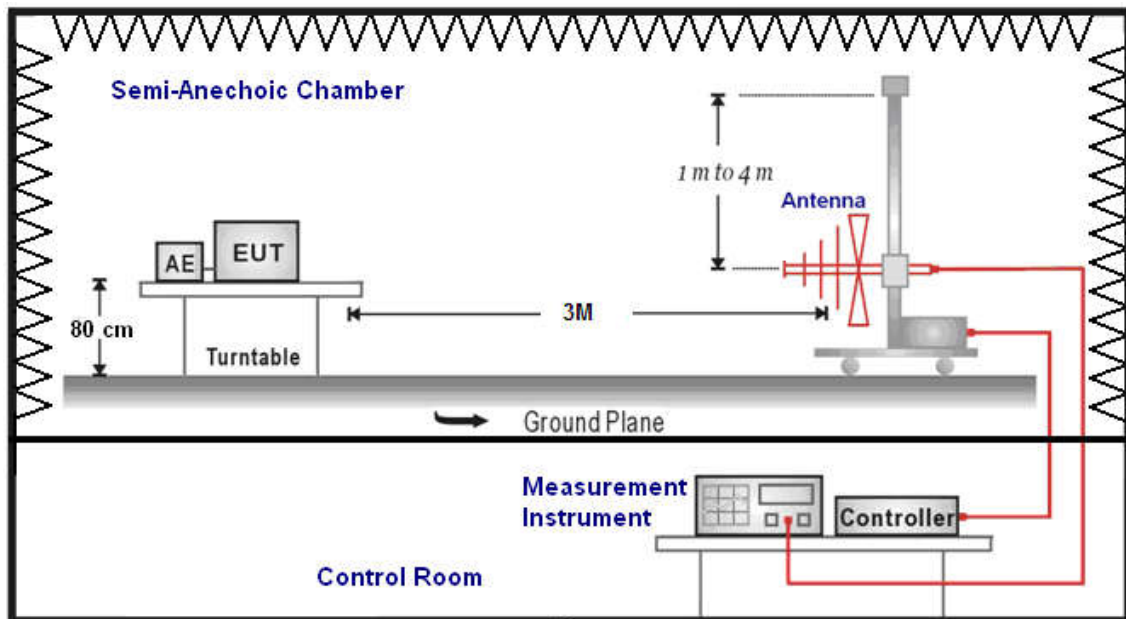

Above 1GHz

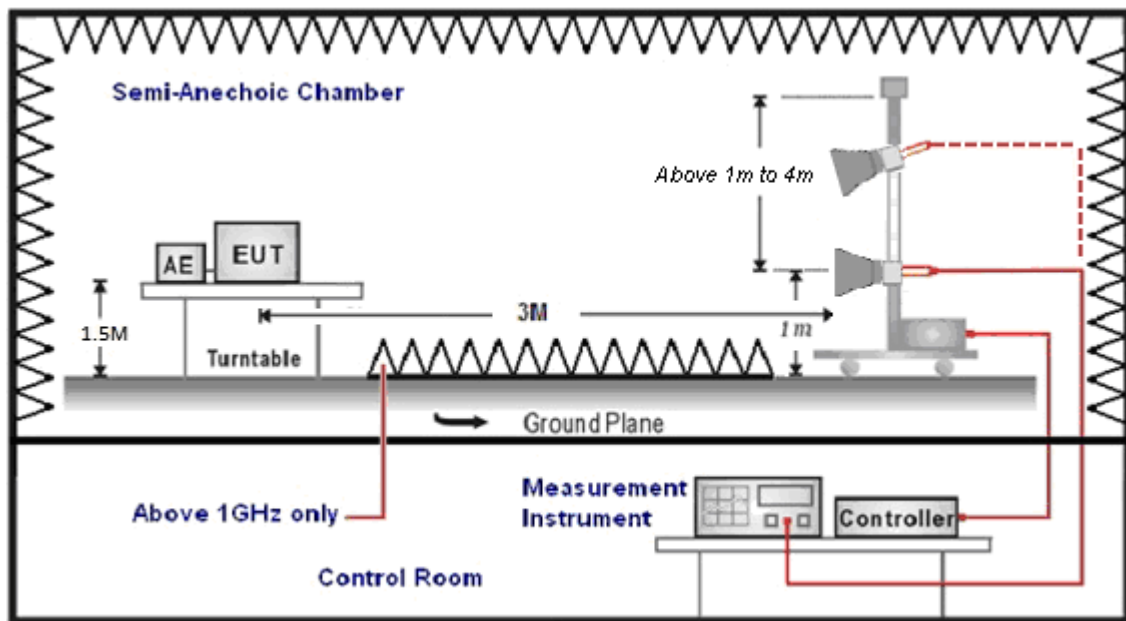

## ■ Test Procedure

Final radiation measurements were made on a three-meter, Semi Anechoic Chamber. The EUT system was placed on a nonconductive turntable which is 0.8 or 1.5 meters height (below 1GHz use 0.8m turntable / above 1GHz use 1.5m turntable), top surface 1.0 x 1.5 meter. The spectrum was examined from 250 MHz to 2.5 GHz in order to cover the whole spectrum below 10th harmonic which could generate from the EUT. During the test, EUT was set to transmit continuously & Measurements spectrum range from 9 kHz to 26.5 GHz is investigated.

For measurements below 1 GHz the resolution bandwidth is set to 100 kHz for peak detection measurements or 120 kHz for quasi-peak detection measurements. Peak detection is used unless otherwise noted as quasi-peak.

For measurements above 1 GHz the resolution bandwidth is set to 1 MHz, and then the video bandwidth is set to 1 MHz for peak measurements and 10 Hz for average measurements.

A nonconductive material surrounded the EUT to supporting the EUT for standing on three orthogonal planes. At each condition, the EUT was rotated 360 degrees, and the antenna was raised and lowered from one to four meters to find the maximum emission levels. Measurements were taken using both horizontal and vertical antenna polarization.

SCHWARZBECK MESS-ELEKTRONIK Biconilog Antenna at 3 Meter and the SCHWARZBECK Double Ridged Guide Antenna was used in frequencies 1 – 26.5 GHz at a distance of 1 meter. All test results were extrapolated to equivalent signal at 3 meters utilizing an inverse linear distance extrapolation Factor (20dB/decade).

For testing above 1GHz, the emission level of the EUT in peak mode was 20dB lower than average limit (that means the emission level in peak mode also complies with the limit in average mode), then testing will be stopped and peak values of EUT will be reported, otherwise, the emissions will be measured in average mode again and reported.

Appropriate preamplifiers were used for improving sensitivity and precautions were taken to avoid overloading or desensitizing the spectrum analyzer. No post – detector video filters were used in the test.

The spectrum analyzer's 6 dB bandwidth was set to 1 MHz, and the analyzer was operated in the peak detection mode, for frequencies both below and up 1 GHz. The average levels were obtained by subtracting the duty cycle correction factor from the peak readings.

The following procedures were used to convert the emission levels measured in decibels referenced to 1 microvolt (dBuV) into field intensity in micro volts pre meter (uV/m).

The actual field intensity in decibels referenced to 1 microvolt in to field intensity in micro volts per meter (dBuV/m).

The actual field intensity in decibels referenced to 1 microvolt per meter (dBuV/m) is determined by algebraically adding the measured reading in dBuV, the antenna factor (dB), and cable loss (dB) and Subtracting the gain of preamplifier (dB) is auto calculate in spectrum analyzer.

$$(1) \text{ Amplitude (dBuV/m) = FI (dBuV) + AF (dB) + CL (dB) - Gain (dB)}$$

FI= Reading of the field intensity.

AF= Antenna factor.

CL= Cable loss.

P.S Amplitude is auto calculate in spectrum analyzer.

$$(2) \text{ Actual Amplitude (dBuV/m) = Amplitude (dBuV) - Dis(dB)}$$

The FCC specified emission limits were calculated according the EUT operating frequency and by following linear interpolation equations:

(a) For fundamental frequency : Transmitter Output < +30dBm

(b) For spurious frequency : Spurious emission limits = fundamental emission limit /10

Data of measurement within this frequency range without mark in the table above means the reading of emissions are attenuated more than 20dB below the permissible limits or the field strength is too small to be measured.



### 4.3. Maximum Conducted Output Power Measurement

#### ■ Limit

For frequency hopping systems operating in the 2400–2483.5 MHz band employing at least 75 non-overlapping hopping channels < 0.125 watt.

#### ■ Test Setup

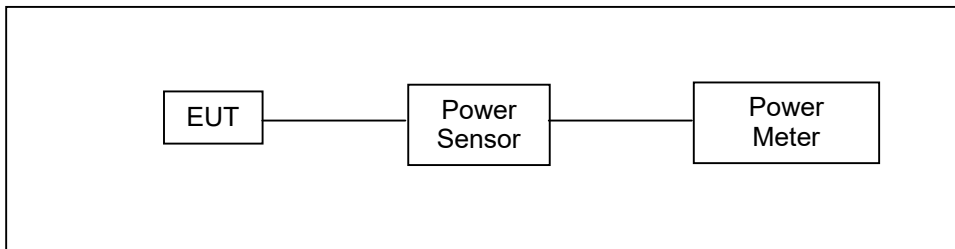

#### ■ Test Procedure

Testing must be done according to this procedure, FCC Public Notice DA 00-705 - Filing and Measurement Guidelines for Frequency Hopping Spread Spectrum Systems. This is the only method recognized by the FCC. The tests below are run with the EUT's transmitter set at high power in TX mode. The EUT is needed to force selection of output power level and channel number. While testing, EUT was set to transmit continuously. Remove the Subjective device's antenna and connect the RF output port to power sensor. The maximum peak output power shall not exceed 1 watt.

Use a direct connection between the antenna port of transmitter and the power sensor, for prevent the power sensor input attenuation 40-50 dB. Set the RBW Bandwidth of the emission or use a channel power meter mode. For antennas with gains of 6 dBi or less, maximum allowed transmitter output is 1 watt (+30 dBm). For antennas with gains greater than 6 dBi, transmitter output level must be decreased by an amount equal to (GAIN - 6)/3 dBm. The antenna port of the EUT was connected to the input of a power sensor. Power was read directly and cable loss correction was added to the reading to obtain power at the EUT antenna terminals.

#### 4.4. 20dB RF Bandwidth Measurement

■ **Limit**

N/A

■ **Test Setup**

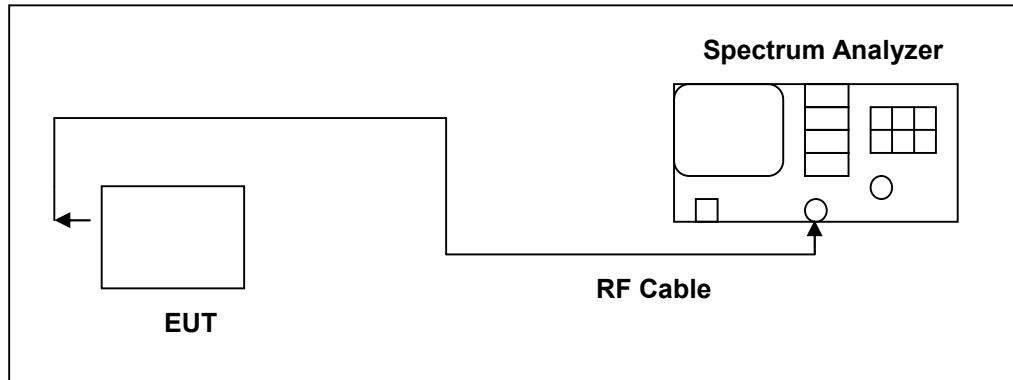

■ **Test Procedure**

Testing must be done according to this procedure, FCC Public Notice DA 00-705 - Filing and Measurement Guidelines for Frequency Hopping Spread Spectrum Systems. This is the only method recognized by the FCC. The RF output port of the Equipment-Under-Test is directly coupled to the input of the EMC analyzer through a specialized RF connector and a 10dB passive attenuator. A fully charged battery was used for the supply voltage. The Bluetooth frequency hopping function of the EUT was enabled. The spectrum analyzer used the following settings:

1. Span = approx. 2 to 3 times the 20dB bandwidth, centered on a hopping frequency
2. RBW  $\geq$  1% of the 20dB span
3. VBW  $\geq$  RBW
4. Sweep = auto
5. Detector function = peak
6. Trace = max hold

The trace was allowed to stabilize. The EUT was transmitting at its maximum data rate. The marker-to-peak function was used to set the marker to the peak of the emission. The marker-delta function was used to measure 20dB down one side of the emission. The marker-delta function and marker was moved to the other side of the emission until it was even with the reference marker. The marker-delta reading at this point was the 20dB bandwidth of the emission.

## 4.5. Carrier Frequency Separation Measurement

### ■ Limit

Title 47 of the CFR, Part 15 Subpart (c) 15.247(a)(1) requires the measurement of the bandwidth of the transmission between the -20 dB points on the transmitted spectrum. The results of this test determine the limits for channel spacing. The channel spacing shall be a minimum of 25 kHz or the 20 dB bandwidth, whichever is greater. Alternatively, frequency hopping systems operating in the 2400-2483.5 MHz band may have hopping channel carrier frequencies that are separated by 25 kHz or two-thirds of the 20 dB bandwidth of the hopping channel.

### ■ Test Setup

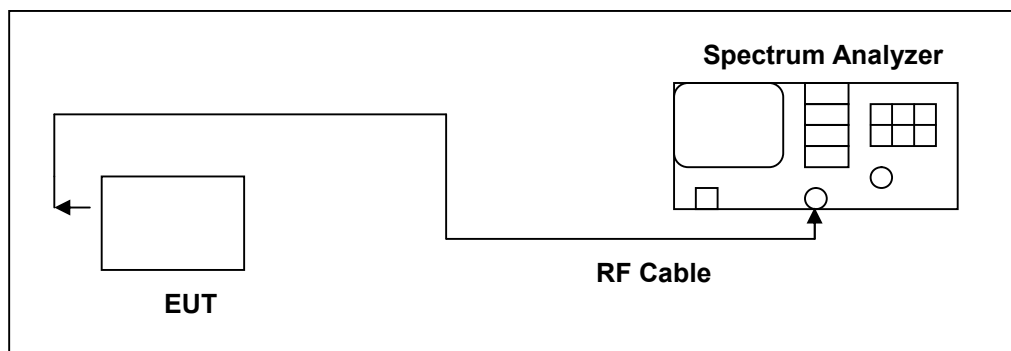

### ■ Test Procedure

Testing must be done according to this procedure, FCC Public Notice DA 00-705 - Filing and Measurement Guidelines for Frequency Hopping Spread Spectrum Systems. This is the only method recognized by the FCC. The RF output port of the Equipment-Under-Test is directly coupled to the input of the EMC analyzer through a specialized RF connector and a 10dB passive attenuator. A fully charged battery was used for the supply voltage. The Bluetooth frequency hopping function of the EUT was enabled. The following spectrum analyzer settings were used:

1. Span = wide enough to capture the peaks of two adjacent channels
2. Resolution (or IF) Bandwidth (RBW)  $\geq$  1% of the span
3. Video (or Average) Bandwidth (VBW)  $\geq$  RBW
4. Sweep = auto
5. Detector function = peak
6. Trace = max hold

The trace was allowed to stabilize. The marker-delta function was used to determine the separation between the peaks of the adjacent channels.

## 4.6. Number of Hopping Measurement

### ■ Limit

Frequency hopping systems in the 2400–2483.5 MHz band shall use at least 15 channels.

### ■ Test Setup

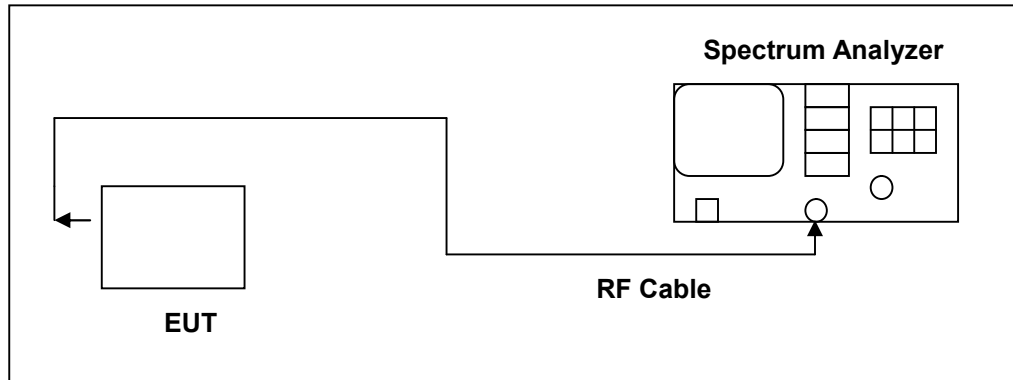

### ■ Test Procedure

Testing must be done according to this procedure, FCC Public Notice DA 00-705 - Filing and Measurement Guidelines for Frequency Hopping Spread Spectrum Systems. This is the only method recognized by the FCC. The RF output port of the Equipment-Under-Test is directly coupled to the input of the EMC analyzer through a specialized RF connector and a 10dB passive attenuator. A fully charged battery was used for the supply voltage. The Bluetooth frequency hopping function of the EUT was enabled. The spectrum analyzer used the following settings:

1. Span = the frequency band of operation
2. RBW  $\geq$  1% of the span
3. VBW  $\geq$  RBW
4. Sweep = auto
5. Detector function = peak
6. Trace = max hold

The trace was allowed to stabilize.

## 4.7. Time of Occupancy (Dwell Time) Measurement

### ■ Limit

The average time of occupancy on any channel shall not be greater than 0.4 seconds within a period of 0.4 seconds multiplied by the number of hopping channels employed.

### ■ Test Setup

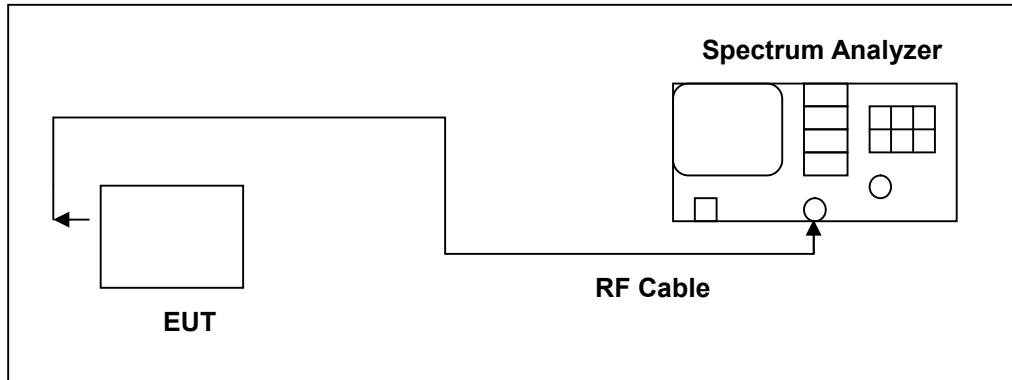

### ■ Test Procedure

Testing must be done according to this procedure, FCC Public Notice DA 00-705 - Filing and Measurement Guidelines for Frequency Hopping Spread Spectrum Systems. This is the only method recognized by the FCC. The RF output port of the Equipment-Under-Test is directly coupled to the input of the spectrum through a specialized RF connector and a 10dB passive attenuator. A fully charged battery was used for the supply voltage. The Bluetooth hopping function of the EUT was enabled. The following spectrum analyzer settings were used:

1. Span = zero span, centered on a hopping channel
2. RBW = 1 MHz
3. VBW  $\geq$  RBW
4. Sweep = as necessary to capture the entire dwell time per hopping channel
5. Detector function = peak
6. Trace = max hold

The marker-delta function was used to determine the dwell time.

## 4.8. Out of Band Conducted Emissions Measurement

### ■ Limit

In any 100 kHz bandwidth outside the frequency band in which the spread spectrum or digitally modulated intentional radiator is operating, the radio frequency power that is produced by the intentional radiator shall be at least 20 dB below that in the 100 kHz bandwidth within the band that contains the highest level of the desired power

### ■ Test Setup

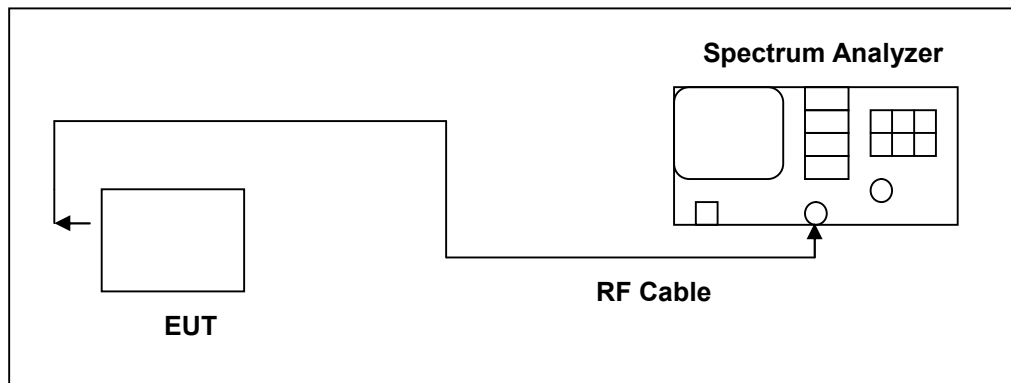

### ■ Test Procedure

Testing must be done according to this procedure, FCC Public Notice DA 00-705 - Filing and Measurement Guidelines for Frequency Hopping Spread Spectrum Systems. This is the only method recognized by the FCC. In any 100 kHz bandwidth outside the EUT pass band, the RF power produced by the modulation products of the spreading sequence, the information sequence, and the carrier frequency shall be at least 20 dB below that of the maximum in-band 100 kHz emission, antenna output of the EUT was coupled directly to spectrum analyzer; if an external attenuator and/or cable was used, these losses are compensated for with the analyzer OFFSET function. All other types of emissions from the EUT shall meet the general limits for radiated frequencies outside the pass band. The test was performed at 3 channels (Channel 0, 39, 78)

## 4.9. Antenna Measurement

### ■ Limit

For intentional device, according to 15.203, an intentional radiator shall be designed to ensure that no antenna other than that furnished by the responsible party shall be used with the device.

And According to 15.247 (b)(4), if transmitting antennas of directional gain greater than 6 dBi are used, the power shall be reduced by the amount in dB that the directional gain of the antenna exceeds 6dBi.

### ■ Antenna Connector Construction

See section 2 – antenna information.

## 5 Test Results

### Annex A. Conducted Emission

■ Test Result

Standard:	FCC Part 15.247	Line:	L1
Test item:	Conducted Emission	Power:	AC 120V/60Hz
Test Mode:	Mode 1	Temp.(°C)/Hum.(%RH):	26(°C)/60%RH
Description:			

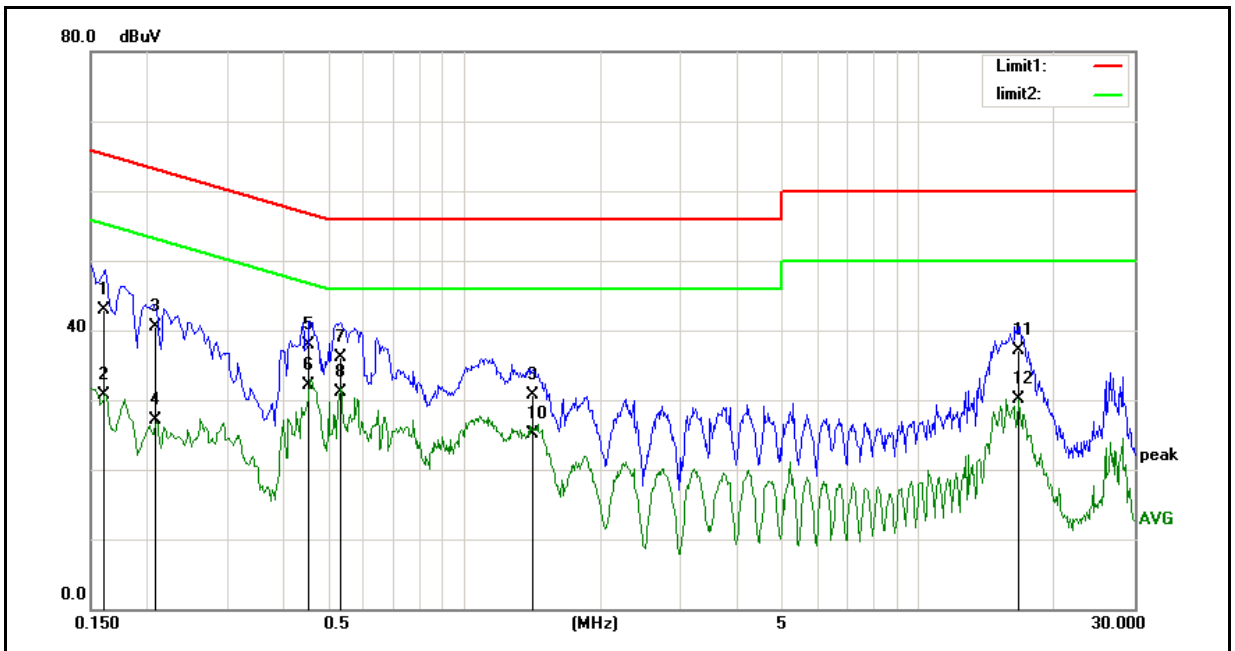

No.	Frequency	Reading	Correct	Result	Limit	Margin	Remark
	(MHz)	(dBuV)	Factor(dB)	(dBuV)	(dBuV)	(dB)	
1	0.1602	31.54	11.40	42.94	65.45	-22.51	QP
2	0.1602	19.24	11.40	30.64	55.45	-24.81	AVG
3	0.2091	29.49	11.06	40.55	63.24	-22.69	QP
4	0.2091	16.13	11.06	27.19	53.24	-26.05	AVG
5	0.4566	27.66	10.24	37.90	56.75	-18.85	QP
6	0.4566	21.87	10.24	32.11	46.75	-14.64	AVG
7	0.5347	26.01	10.17	36.18	56.00	-19.82	QP
8	0.5347	20.94	10.17	31.11	46.00	-14.89	AVG
9	1.4156	20.56	10.10	30.66	56.00	-25.34	QP
10	1.4156	15.03	10.10	25.13	46.00	-20.87	AVG
11	16.6040	27.03	10.16	37.19	60.00	-22.81	QP
12	16.6040	19.88	10.16	30.04	50.00	-19.96	AVG

Note: 1. Result (dBuV/m) = Correct Factor (dB/m) + Reading(dBuV).

2. Correction factor (dB) = Cable loss (dB) + L.I.S.N. factor (dB).



Standard:	FCC Part 15.247	Line:	N
Test item:	Conducted Emission	Power:	AC 120V/60Hz
Test Mode:	Mode 1	Temp.(°C)/Hum.(%RH):	26(°C)/60%RH
Description:			

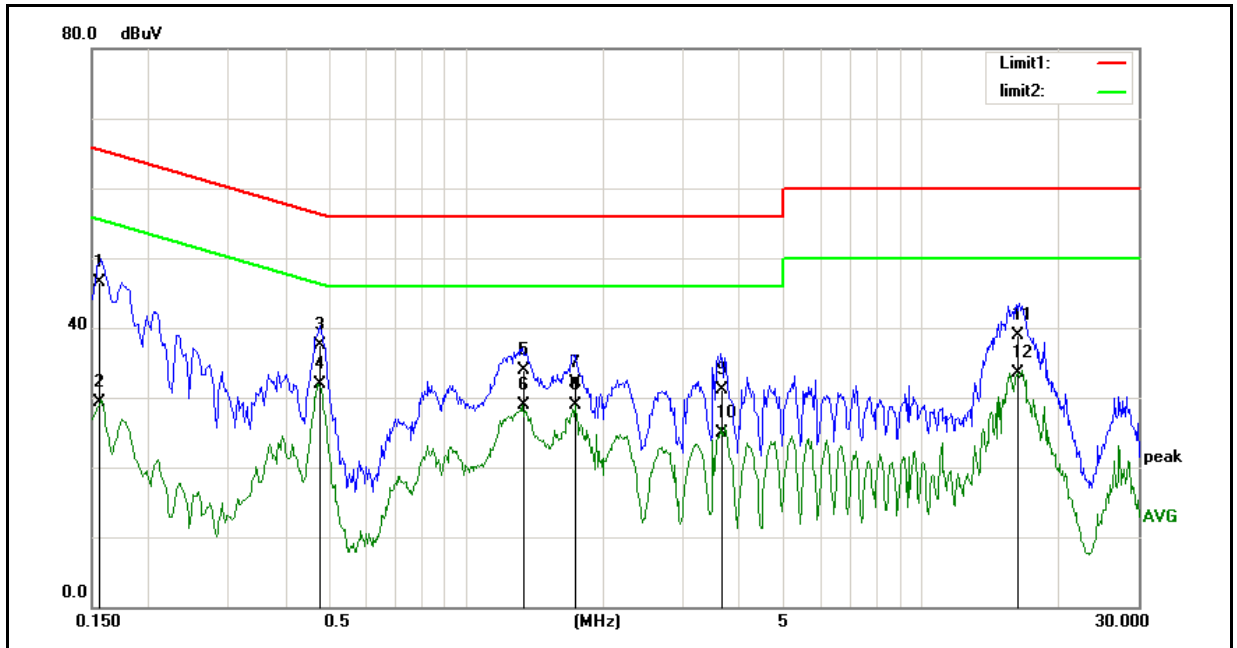

No.	Frequency	Reading	Correct	Result	Limit	Margin	Remark
	(MHz)	(dBuV)	Factor(dB)	(dBuV)	(dBuV)	(dB)	
1	0.1553	34.99	11.43	46.42	65.71	-19.29	QP
2	0.1553	17.81	11.43	29.24	55.71	-26.47	AVG
3	0.4757	27.25	10.21	37.46	56.41	-18.95	QP
4	0.4757	21.77	10.21	31.98	46.41	-14.43	AVG
5	1.3444	23.73	10.10	33.83	56.00	-22.17	QP
6	1.3444	18.87	10.10	28.97	46.00	-17.03	AVG
7	1.7419	21.91	10.11	32.02	56.00	-23.98	QP
8	1.7419	18.77	10.11	28.88	46.00	-17.12	AVG
9	3.6433	20.91	10.15	31.06	56.00	-24.94	QP
10	3.6433	14.73	10.15	24.88	46.00	-21.12	AVG
11	16.3259	28.78	10.16	38.94	60.00	-21.06	QP
12	16.3259	23.29	10.16	33.45	50.00	-16.55	AVG

Note: 1. Result (dBuV/m) = Correct Factor (dB/m) + Reading(dBuV).

2. Correction factor (dB) = Cable loss (dB) + L.I.S.N. factor (dB).

## Annex B. Conducted Test Results

### ■ Test Result

Test Item	Maximum Conducted Output Power						
Test Mode	Frequency (MHz)	Packet Type	Average Power		Peak Power		Limit (W)
			(dBm)	(W)	(dBm)	(W)	
Mode 2	2402	DH1	-4.45	0.00036	-3.97	0.00040	< 0.125
		DH3	-4.30	0.00037	-3.92	0.00041	< 0.125
		DH5	-4.26	0.00037	-3.87	0.00041	< 0.125
	2441	DH1	-3.86	0.00041	-3.39	0.00046	< 0.125
		DH3	-3.72	0.00042	-3.31	0.00047	< 0.125
		DH5	-3.69	0.00043	-3.28	0.00047	< 0.125
	2480	DH1	-2.71	0.00054	-2.26	0.00059	< 0.125
		DH3	-2.57	0.00055	-2.23	0.00060	< 0.125
		DH5	<b>-2.55</b>	<b>0.00056</b>	<b>-2.18</b>	<b>0.00061</b>	< 0.125
Mode 3	2402	2DH1	-4.13	0.00039	-0.61	0.00087	< 0.125
		2DH3	-4.11	0.00039	-0.59	0.00087	< 0.125
		2DH5	-4.03	0.00040	-0.54	0.00088	< 0.125
	2441	2DH1	-3.64	0.00043	-0.18	0.00096	< 0.125
		2DH3	-3.56	0.00044	-0.04	0.00099	< 0.125
		2DH5	-3.52	0.00044	0.09	0.00102	< 0.125
	2480	2DH1	-2.46	0.00057	0.93	0.00124	< 0.125
		2DH3	-2.39	0.00058	1.01	0.00126	< 0.125
		2DH5	<b>-2.34</b>	<b>0.00058</b>	<b>1.13</b>	<b>0.00130</b>	< 0.125
Mode 4	2402	3DH1	-3.95	0.00040	-0.42	0.00091	< 0.125
		3DH3	-3.93	0.00040	-0.42	0.00091	< 0.125
		3DH5	-3.83	0.00041	-0.39	0.00091	< 0.125
	2441	3DH1	-3.49	0.00045	0.09	0.00102	< 0.125
		3DH3	-3.45	0.00045	0.13	0.00103	< 0.125
		3DH5	-3.41	0.00046	0.16	0.00104	< 0.125
	2480	3DH1	-2.29	0.00059	1.32	0.00136	< 0.125
		3DH3	-2.25	0.00060	1.37	0.00137	< 0.125
		3DH5	<b>-2.22</b>	<b>0.00060</b>	<b>1.49</b>	<b>0.00141</b>	< 0.125



Note: The relevant measured result has the offset with cable loss already.

## ■ Test Result

Test Item	20dB RF Bandwidth Measurement	
Test Mode	Frequency (MHz)	Measurement Results (kHz)
Mode 2	2402	846.2
	2441	845.8
	2480	844.4
Mode 4	2402	1251
	2441	1263
	2480	1267

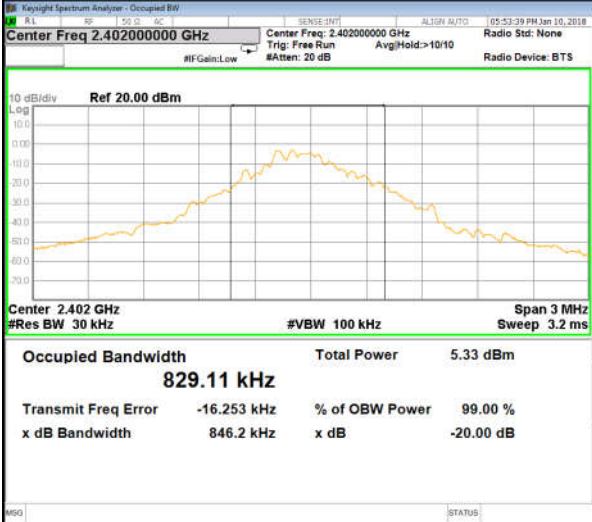
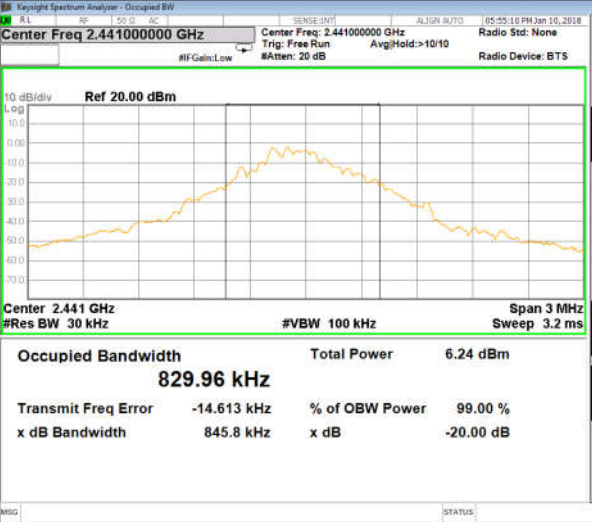
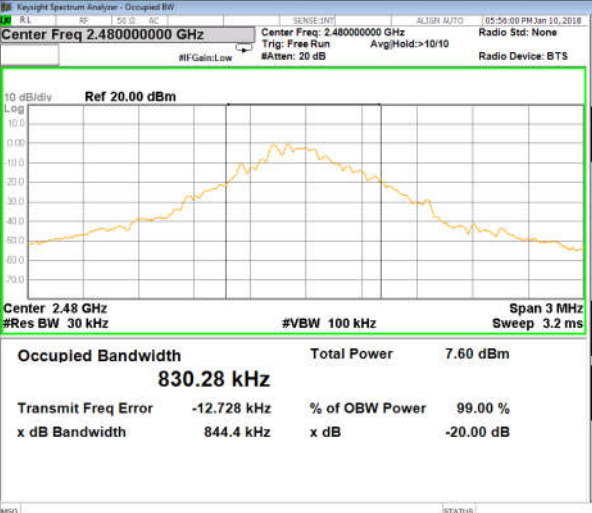
■ Test Graphs

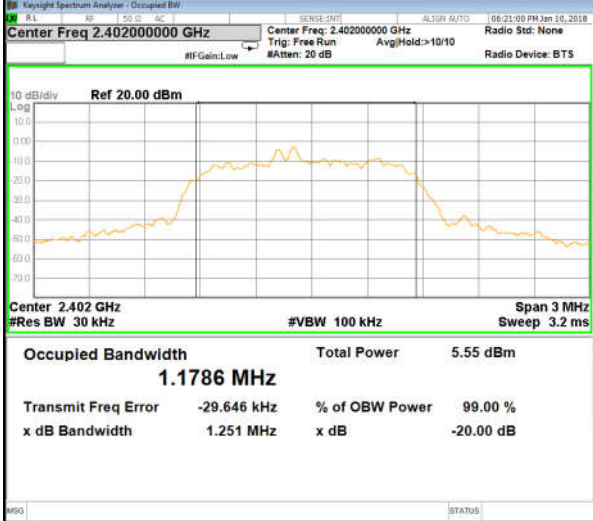
Test Item	20dB RF Bandwidth Measurement	
Mode 2: GFSK Continuous TX mode		
2402 MHz	 <p>Center Freq 2.40200000 GHz</p> <p>Center Freq: 2.40200000 GHz Trig: Free Run Avg/Hold:&gt;10/10 Radio Std: None Radio Device: BTS</p> <p>10 dB/div Ref 20.00 dBm</p> <p>Center 2.402 GHz #Res BW 30 kHz #VBW 100 kHz Span 3 MHz Sweep 3.2 ms</p> <p><b>Occupied Bandwidth 829.11 kHz</b></p> <p>Total Power 5.33 dBm</p> <p>Transmit Freq Error -16.253 kHz % of OBW Power 99.00 % x dB Bandwidth 846.2 kHz x dB -20.00 dB</p>	<p>Frequency</p> <p>Center Freq 2.40200000 GHz</p> <p>CF Step 300.000 kHz Auto Man</p> <p>Freq Offset 0 Hz</p>
2441 MHz	 <p>Center Freq 2.44100000 GHz</p> <p>Center Freq: 2.44100000 GHz Trig: Free Run Avg/Hold:&gt;10/10 Radio Std: None Radio Device: BTS</p> <p>10 dB/div Ref 20.00 dBm</p> <p>Center 2.441 GHz #Res BW 30 kHz #VBW 100 kHz Span 3 MHz Sweep 3.2 ms</p> <p><b>Occupied Bandwidth 829.96 kHz</b></p> <p>Total Power 6.24 dBm</p> <p>Transmit Freq Error -14.613 kHz % of OBW Power 99.00 % x dB Bandwidth 845.8 kHz x dB -20.00 dB</p>	<p>Frequency</p> <p>Center Freq 2.44100000 GHz</p> <p>CF Step 300.000 kHz Auto Man</p> <p>Freq Offset 0 Hz</p>
2480 MHz	 <p>Center Freq 2.48000000 GHz</p> <p>Center Freq: 2.48000000 GHz Trig: Free Run Avg/Hold:&gt;10/10 Radio Std: None Radio Device: BTS</p> <p>10 dB/div Ref 20.00 dBm</p> <p>Center 2.48 GHz #Res BW 30 kHz #VBW 100 kHz Span 3 MHz Sweep 3.2 ms</p> <p><b>Occupied Bandwidth 830.28 kHz</b></p> <p>Total Power 7.60 dBm</p> <p>Transmit Freq Error -12.728 kHz % of OBW Power 99.00 % x dB Bandwidth 844.4 kHz x dB -20.00 dB</p>	<p>Frequency</p> <p>Center Freq 2.48000000 GHz</p> <p>CF Step 300.000 kHz Auto Man</p> <p>Freq Offset 0 Hz</p>

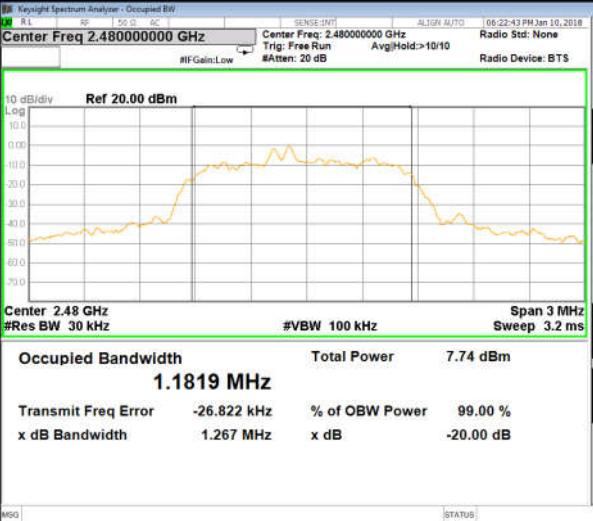
Test Item	20dB RF Bandwidth Measurement	
Mode 4: 8DPSK Continuous TX mode		
2402 MHz	 <p>Center Freq 2.40200000 GHz</p> <p>Center Freq: 2.40200000 GHz</p> <p>Trig: Free Run Avg/Hold:&gt;10/10</p> <p>#IFGain:Low #Atten: 20 dB</p> <p>Radio Std: None</p> <p>Radio Device: BTS</p> <p>10 dB/div Ref 20.00 dBm</p> <p>Center 2.402 GHz #Res BW 30 kHz #VBW 100 kHz Span 3 MHz Sweep 3.2 ms</p> <p><b>Occupied Bandwidth 1.1786 MHz</b></p> <p>Total Power 5.55 dBm</p> <p>Transmit Freq Error -29.646 kHz % of OBW Power 99.00 %</p> <p>x dB Bandwidth 1.251 MHz x dB -20.00 dB</p> <p>Frequency 2.40200000 GHz</p> <p>Center Freq 2.40200000 GHz</p> <p>CF Step 300.000 kHz</p> <p>Freq Offset 0 Hz</p>	
2441 MHz	 <p>Center Freq 2.44100000 GHz</p> <p>Center Freq: 2.44100000 GHz</p> <p>Trig: Free Run Avg/Hold:&gt;10/10</p> <p>#IFGain:Low #Atten: 20 dB</p> <p>Radio Std: None</p> <p>Radio Device: BTS</p> <p>10 dB/div Ref 20.00 dBm</p> <p>Center 2.441 GHz #Res BW 30 kHz #VBW 100 kHz Span 3 MHz Sweep 3.2 ms</p> <p><b>Occupied Bandwidth 1.1790 MHz</b></p> <p>Total Power 6.38 dBm</p> <p>Transmit Freq Error -27.719 kHz % of OBW Power 99.00 %</p> <p>x dB Bandwidth 1.263 MHz x dB -20.00 dB</p> <p>Frequency 2.44100000 GHz</p> <p>Center Freq 2.44100000 GHz</p> <p>CF Step 300.000 kHz</p> <p>Freq Offset 0 Hz</p>	
2480 MHz	 <p>Center Freq 2.48000000 GHz</p> <p>Center Freq: 2.48000000 GHz</p> <p>Trig: Free Run Avg/Hold:&gt;10/10</p> <p>#IFGain:Low #Atten: 20 dB</p> <p>Radio Std: None</p> <p>Radio Device: BTS</p> <p>10 dB/div Ref 20.00 dBm</p> <p>Center 2.48 GHz #Res BW 30 kHz #VBW 100 kHz Span 3 MHz Sweep 3.2 ms</p> <p><b>Occupied Bandwidth 1.1819 MHz</b></p> <p>Total Power 7.74 dBm</p> <p>Transmit Freq Error -26.822 kHz % of OBW Power 99.00 %</p> <p>x dB Bandwidth 1.267 MHz x dB -20.00 dB</p> <p>Frequency 2.48000000 GHz</p> <p>Center Freq 2.48000000 GHz</p> <p>CF Step 300.000 kHz</p> <p>Freq Offset 0 Hz</p>	

■ Test Graphs

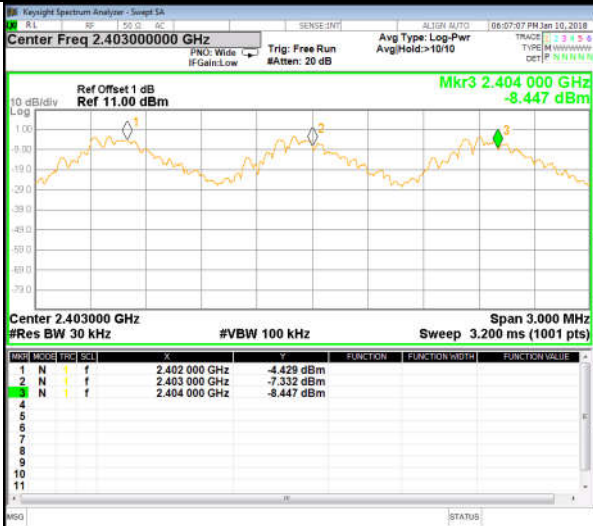
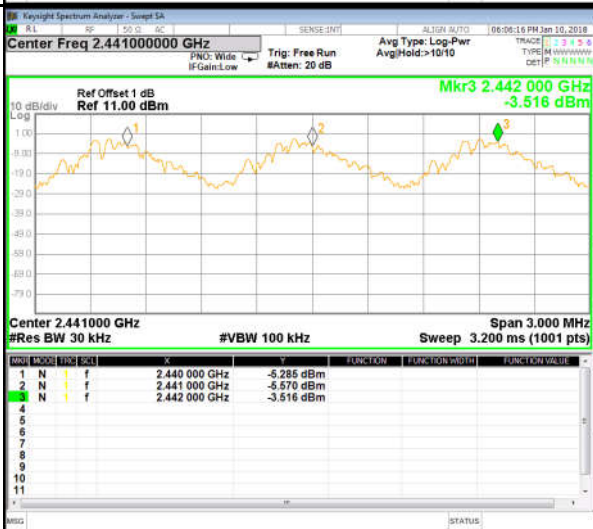
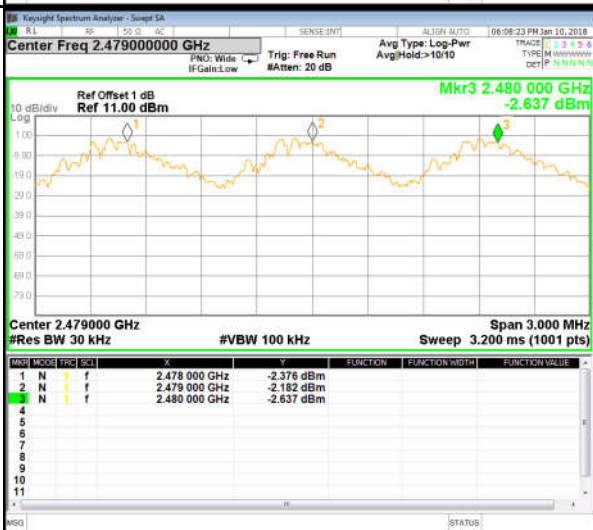
Test Item	Carrier Frequency Separation Measurement	
Mode 2: GFSK Continuous TX mode		
2402 MHz		<p>Frequency</p> <p>Auto Tune</p> <p>Center Freq 2.40300000 GHz</p> <p>Start Freq 2.401500000 GHz</p> <p>Stop Freq 2.404500000 GHz</p> <p>CF Step 300.000 kHz</p> <p>Freq Offset 0 Hz</p>
2441 MHz		<p>Frequency</p> <p>Auto Tune</p> <p>Center Freq 2.44100000 GHz</p> <p>Start Freq 2.439500000 GHz</p> <p>Stop Freq 2.442500000 GHz</p> <p>CF Step 300.000 kHz</p> <p>Freq Offset 0 Hz</p>
2480 MHz		<p>Frequency</p> <p>Auto Tune</p> <p>Center Freq 2.47900000 GHz</p> <p>Start Freq 2.477500000 GHz</p> <p>Stop Freq 2.480500000 GHz</p> <p>CF Step 300.000 kHz</p> <p>Freq Offset 0 Hz</p>

Test Item	Carrier Frequency Separation Measurement
-----------	--

Mode 4: 8DPSK Continuous TX mode

2402 MHz	<p>Center Freq 2.40300000 GHz</p> <p>Mkr3 2.404 000 GHz -10.431 dBm</p> <p>Center 2.403000 GHz #VBW 100 kHz Span 3.000 MHz #Res BW 30 kHz Sweep 3.200 ms (1001 pts)</p> <table border="1"> <thead> <tr> <th>Mag</th> <th>Mode</th> <th>Trig</th> <th>Scale</th> <th>Center</th> <th>Power</th> <th>Function</th> <th>Function Width</th> <th>Function Value</th> </tr> </thead> <tbody> <tr> <td>1</td> <td>N</td> <td>f</td> <td></td> <td>2.402 000 GHz</td> <td>-10.454 dBm</td> <td></td> <td></td> <td></td> </tr> <tr> <td>2</td> <td>N</td> <td>f</td> <td></td> <td>2.403 000 GHz</td> <td>-10.346 dBm</td> <td></td> <td></td> <td></td> </tr> <tr> <td>3</td> <td>N</td> <td>f</td> <td></td> <td>2.404 000 GHz</td> <td>-10.431 dBm</td> <td></td> <td></td> <td></td> </tr> </tbody> </table>	Mag	Mode	Trig	Scale	Center	Power	Function	Function Width	Function Value	1	N	f		2.402 000 GHz	-10.454 dBm				2	N	f		2.403 000 GHz	-10.346 dBm				3	N	f		2.404 000 GHz	-10.431 dBm				<p>Frequency</p> <p>Auto Tune</p> <p>Center Freq 2.40300000 GHz</p> <p>Start Freq 2.401500000 GHz</p> <p>Stop Freq 2.404500000 GHz</p> <p>CF Step 300.000 kHz Man</p> <p>Freq Offset 0 Hz</p>
Mag	Mode	Trig	Scale	Center	Power	Function	Function Width	Function Value																														
1	N	f		2.402 000 GHz	-10.454 dBm																																	
2	N	f		2.403 000 GHz	-10.346 dBm																																	
3	N	f		2.404 000 GHz	-10.431 dBm																																	

2441 MHz	<p>Center Freq 2.44100000 GHz</p> <p>Mkr3 2.442 000 GHz -11.257 dBm</p> <p>Center 2.441000 GHz #VBW 100 kHz Span 3.000 MHz #Res BW 30 kHz Sweep 3.200 ms (1001 pts)</p> <table border="1"> <thead> <tr> <th>Mag</th> <th>Mode</th> <th>Trig</th> <th>Scale</th> <th>Center</th> <th>Power</th> <th>Function</th> <th>Function Width</th> <th>Function Value</th> </tr> </thead> <tbody> <tr> <td>1</td> <td>N</td> <td>f</td> <td></td> <td>2.440 000 GHz</td> <td>-9.956 dBm</td> <td></td> <td></td> <td></td> </tr> <tr> <td>2</td> <td>N</td> <td>f</td> <td></td> <td>2.441 000 GHz</td> <td>-9.943 dBm</td> <td></td> <td></td> <td></td> </tr> <tr> <td>3</td> <td>N</td> <td>f</td> <td></td> <td>2.442 000 GHz</td> <td>-11.257 dBm</td> <td></td> <td></td> <td></td> </tr> </tbody> </table>	Mag	Mode	Trig	Scale	Center	Power	Function	Function Width	Function Value	1	N	f		2.440 000 GHz	-9.956 dBm				2	N	f		2.441 000 GHz	-9.943 dBm				3	N	f		2.442 000 GHz	-11.257 dBm				<p>Frequency</p> <p>Auto Tune</p> <p>Center Freq 2.441000000 GHz</p> <p>Start Freq 2.439500000 GHz</p> <p>Stop Freq 2.442500000 GHz</p> <p>CF Step 300.000 kHz Man</p> <p>Freq Offset 0 Hz</p>
Mag	Mode	Trig	Scale	Center	Power	Function	Function Width	Function Value																														
1	N	f		2.440 000 GHz	-9.956 dBm																																	
2	N	f		2.441 000 GHz	-9.943 dBm																																	
3	N	f		2.442 000 GHz	-11.257 dBm																																	

2480 MHz	<p>Center Freq 2.47900000 GHz</p> <p>Mkr3 2.480 000 GHz -8.408 dBm</p> <p>Center 2.479000 GHz #VBW 100 kHz Span 3.000 MHz #Res BW 30 kHz Sweep 3.200 ms (1001 pts)</p> <table border="1"> <thead> <tr> <th>Mag</th> <th>Mode</th> <th>Trig</th> <th>Scale</th> <th>Center</th> <th>Power</th> <th>Function</th> <th>Function Width</th> <th>Function Value</th> </tr> </thead> <tbody> <tr> <td>1</td> <td>N</td> <td>f</td> <td></td> <td>2.478 000 GHz</td> <td>-8.544 dBm</td> <td></td> <td></td> <td></td> </tr> <tr> <td>2</td> <td>N</td> <td>f</td> <td></td> <td>2.479 000 GHz</td> <td>-8.244 dBm</td> <td></td> <td></td> <td></td> </tr> <tr> <td>3</td> <td>N</td> <td>f</td> <td></td> <td>2.480 000 GHz</td> <td>-8.408 dBm</td> <td></td> <td></td> <td></td> </tr> </tbody> </table>	Mag	Mode	Trig	Scale	Center	Power	Function	Function Width	Function Value	1	N	f		2.478 000 GHz	-8.544 dBm				2	N	f		2.479 000 GHz	-8.244 dBm				3	N	f		2.480 000 GHz	-8.408 dBm				<p>Frequency</p> <p>Auto Tune</p> <p>Center Freq 2.479000000 GHz</p> <p>Start Freq 2.477500000 GHz</p> <p>Stop Freq 2.480500000 GHz</p> <p>CF Step 300.000 kHz Man</p> <p>Freq Offset 0 Hz</p>
Mag	Mode	Trig	Scale	Center	Power	Function	Function Width	Function Value																														
1	N	f		2.478 000 GHz	-8.544 dBm																																	
2	N	f		2.479 000 GHz	-8.244 dBm																																	
3	N	f		2.480 000 GHz	-8.408 dBm																																	

## ■ Test Result

Test Item	Number of Hopping Measurement		
Test Mode	Frequency Range (MHz)	Measurement Results (Ch)	Limit (ch)
Mode 2	2402 - 2480	79	> 15
Mode 4	2402 - 2480	79	> 15



■ Test Graphs

Test Item	Number of Hopping Measurement
Mode 2: GFSK Continuous TX mode	
CH0~CH39	 <p>Key parameters from the screenshot:</p> <ul style="list-style-type: none"> <li>Marker 1: 2.4020000000 GHz, -1.850 dBm</li> <li>Start: 2.40000 GHz, Stop: 2.44150 GHz</li> <li>Resolution BW: 1.0 MHz, VBW: 1.0 MHz</li> <li>Sweep: 1.000 ms (1001 pts)</li> <li>Reference Level: 11.00 dBm</li> </ul>
CH40~CH78	 <p>Key parameters from the screenshot:</p> <ul style="list-style-type: none"> <li>Marker 1: 2.48001400000 GHz, 0.309 dBm</li> <li>Start: 2.44150 GHz, Stop: 2.48350 GHz</li> <li>Resolution BW: 1.0 MHz, VBW: 1.0 MHz</li> <li>Sweep: 1.000 ms (1001 pts)</li> <li>Reference Level: 11.00 dBm</li> </ul>

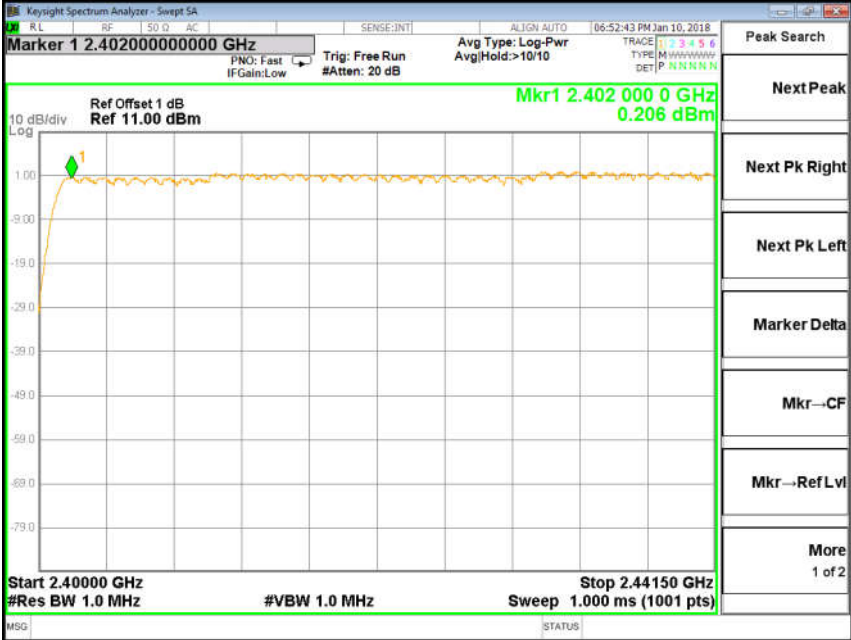
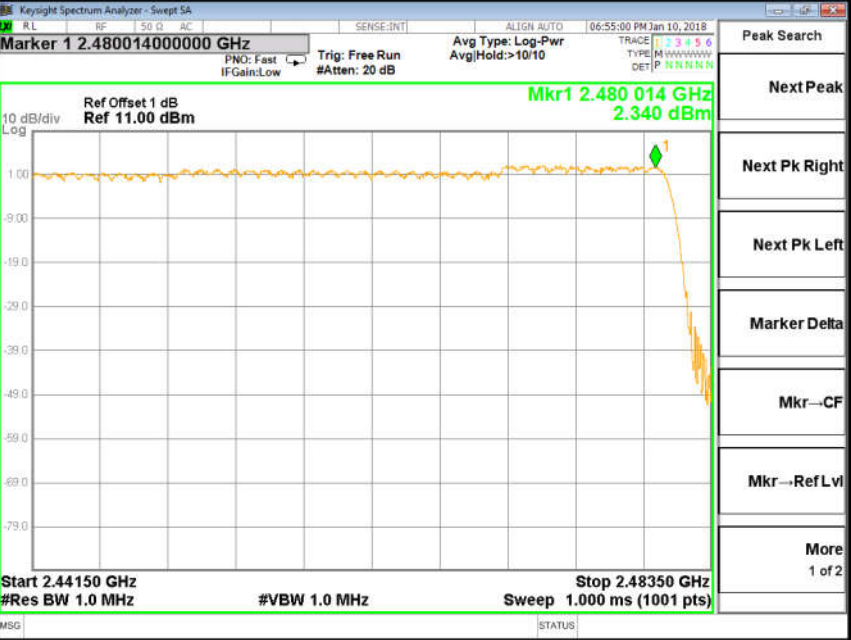
Test Item	Number of Hopping Measurement
Mode 4: 8DPSK Continuous TX mode	
CH0~CH39	 <p>Marker 1 2.4020000000 GHz Mkr1 2.402 000 0 GHz 0.206 dBm</p> <p>Ref Offset 1 dB Ref 11.00 dBm</p> <p>Start 2.40000 GHz #Res BW 1.0 MHz #VBW 1.0 MHz Stop 2.44150 GHz Sweep 1.000 ms (1001 pts)</p>
CH40~CH78	 <p>Marker 1 2.4801400000 GHz Mkr1 2.480 014 GHz 2.340 dBm</p> <p>Ref Offset 1 dB Ref 11.00 dBm</p> <p>Start 2.44150 GHz #Res BW 1.0 MHz #VBW 1.0 MHz Stop 2.48350 GHz Sweep 1.000 ms (1001 pts)</p>

■ Test Result

Test Item	Time of Occupancy (Dwell Time) Measurement
Mode 2: GFSK Continuous TX mode	
DH1	
Cycle Calculate	$79\text{CH} * 0.4 = 31.6 \text{ (sec)}$
The EUT Hopping Number per Sec	1600 times/sec
Each Channel Dwell Times per Sec	$800/79\text{CH} = 10.13(\text{times/sec})$
Each Channel Dwell Times on Cycle(1)	$31.6 * 10.13 = 320.108(\text{times})$
Each Channel Dwell Times (2)	0.45 ms (sec)
Dwell Times on Cycle (1) * (2)	144.05 ms (sec)
LIMIT(msec)	< = 400
DH3	
Cycle Calculate	$79\text{CH} * 0.4 = 31.6 \text{ (sec)}$
The EUT Hopping Number per Sec	1600 times/sec
Each Channel Dwell Times per Sec	$400/79\text{CH} = 5.1(\text{times/sec})$
Each Channel Dwell Times on Cycle(1)	$31.6 * 5.1 = 161.16(\text{times})$
Each Channel Dwell Times (2)	1.7 ms (sec)
Dwell Times on Cycle (1) * (2)	271.82 ms (sec)
LIMIT(msec)	< = 400
DH5	
Cycle Calculate	$79\text{CH} * 0.4 = 31.6 \text{ (sec)}$
The EUT Hopping Number per Sec	1600 times/sec
Each Channel Dwell Times per Sec	$266.7/79\text{CH} = 3.37(\text{times/sec})$
Each Channel Dwell Times on Cycle(1)	$31.6 * 3.37 = 106.492(\text{times})$
Each Channel Dwell Times (2)	2.96 ms (sec)
Dwell Times on Cycle (1) * (2)	316.15 ms (sec)
LIMIT(msec)	< = 400



Test Item	Time of Occupancy (Dwell Time) Measurement
Mode 4: 8DPSK Continuous TX mode	
3DH1	
Cycle Calculate	$79\text{CH} * 0.4 = 31.6 \text{ (sec)}$
The EUT Hopping Number per Sec	1600 times/sec
Each Channel Dwell Times per Sec	$800/79\text{CH} = 10.13(\text{times/sec})$
Each Channel Dwell Times on Cycle(1)	$31.6 * 10.13 = 320.108(\text{times})$
Each Channel Dwell Times (2)	0.45 ms (sec)
Dwell Times on Cycle (1) * (2)	144.05 ms (sec)
LIMIT(msec)	$\leq 400$
3DH3	
Cycle Calculate	$79\text{CH} * 0.4 = 31.6 \text{ (sec)}$
The EUT Hopping Number per Sec	1600 times/sec
Each Channel Dwell Times per Sec	$400/79\text{CH} = 5.1(\text{times/sec})$
Each Channel Dwell Times on Cycle(1)	$31.6 * 5.1 = 161.16(\text{times})$
Each Channel Dwell Times (2)	1.7 ms (sec)
Dwell Times on Cycle (1) * (2)	271.82 ms (sec)
LIMIT(msec)	$\leq 400$
3DH5	
Cycle Calculate	$79\text{CH} * 0.4 = 31.6 \text{ (sec)}$
The EUT Hopping Number per Sec	1600 times/sec
Each Channel Dwell Times per Sec	$266.7/79\text{CH} = 3.37(\text{times/sec})$
Each Channel Dwell Times on Cycle(1)	$31.6 * 3.37 = 106.492(\text{times})$
Each Channel Dwell Times (2)	2.96 ms (sec)
Dwell Times on Cycle (1) * (2)	316.15 ms (sec)
LIMIT(msec)	$\leq 400$

■ Test Graphs

Test Item	Time of Occupancy (Dwell Time) Measurement
Mode 2: GFSK Continuous TX mode	
DH1	 <p>             Marker 1 <math>\Delta</math> 450.000 <math>\mu</math>s              Ref Offset -5 dB              Ref 10.00 dBm  <math>\Delta</math>Mkr1 450.0 <math>\mu</math>s              -1.52 dB              Center 2.441000000 GHz              Res BW 1.0 MHz              #VBW 3.0 MHz              Sweep 10.00 ms (1001 pts)         </p>
DH3	 <p>             Marker 1 <math>\Delta</math> 1.70000 ms              Ref Offset -5 dB              Ref 10.00 dBm  <math>\Delta</math>Mkr1 1.700 ms              1.05 dB              Center 2.441000000 GHz              Res BW 1.0 MHz              #VBW 3.0 MHz              Sweep 10.00 ms (1001 pts)         </p>
DH5	 <p>             Marker 1 <math>\Delta</math> 2.96000 ms              Ref Offset -5 dB              Ref 10.00 dBm  <math>\Delta</math>Mkr1 2.960 ms              0.67 dB              Center 2.441000000 GHz              Res BW 1.0 MHz              #VBW 3.0 MHz              Sweep 10.00 ms (1001 pts)         </p>

Test Item	Time of Occupancy (Dwell Time) Measurement	
Mode 4: 8DPSK Continuous TX mode		
DH1		 <p>             Kayleigh Spectrum Analyzer - Swept SA              Marker 1 <math>\Delta</math> 450.000 <math>\mu</math>s              Ref Offset -5 dB              Ref 10.00 dBm              Avg Type: Log-Pwr  <math>\Delta</math>Mkr1 450.0 <math>\mu</math>s              1.94 dB              Center 2.441000000 GHz              Res BW 1.0 MHz              #VBW 3.0 MHz              Sweep 10.00 ms (1001 pts)         </p>
DH3		 <p>             Kayleigh Spectrum Analyzer - Swept SA              Marker 1 <math>\Delta</math> 1.70000 ms              Ref Offset -5 dB              Ref 10.00 dBm              Avg Type: Log-Pwr  <math>\Delta</math>Mkr1 1.700 ms              -0.23 dB              Center 2.441000000 GHz              Res BW 1.0 MHz              #VBW 3.0 MHz              Sweep 10.00 ms (1001 pts)         </p>
DH5		 <p>             Kayleigh Spectrum Analyzer - Swept SA              Marker 1 <math>\Delta</math> 2.96000 ms              Ref Offset -5 dB              Ref 10.00 dBm              Avg Type: Log-Pwr  <math>\Delta</math>Mkr1 2.960 ms              -1.96 dB              Center 2.441000000 GHz              Res BW 1.0 MHz              #VBW 3.0 MHz              Sweep 10.00 ms (1001 pts)         </p>

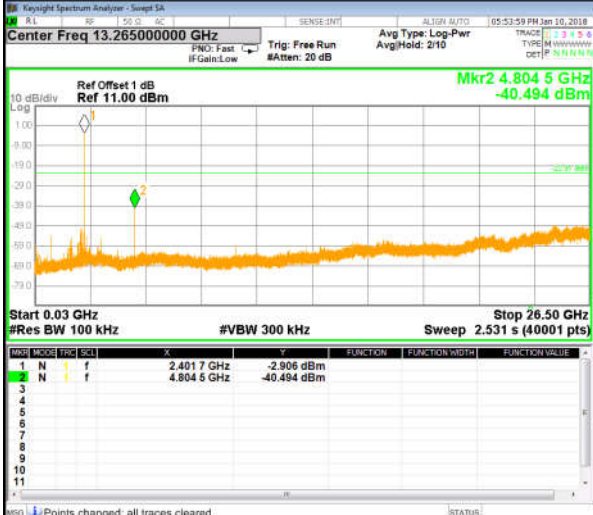
■ Test Graphs

Test Item	Out of Band Conducted Emissions Measurement										
Mode 2: GFSK Continuous TX mode											
2402 MHz	 <p>Center Freq 13.265000000 GHz</p> <p>Mkr2 4.804 5 GHz -40.494 dBm</p> <table border="1"> <thead> <tr> <th>Marker</th> <th>Freq</th> <th>Pwr</th> </tr> </thead> <tbody> <tr> <td>1</td> <td>2.401 7 GHz</td> <td>-2.906 dBm</td> </tr> <tr> <td>2</td> <td>4.804 5 GHz</td> <td>-40.494 dBm</td> </tr> </tbody> </table>	Marker	Freq	Pwr	1	2.401 7 GHz	-2.906 dBm	2	4.804 5 GHz	-40.494 dBm	<p>Frequency</p> <p>Auto Tune</p> <p>Center Freq 13.265000000 GHz</p> <p>Start Freq 30.000000 MHz</p> <p>Stop Freq 26.500000000 GHz</p> <p>CF Step 2.647000000 GHz</p> <p>Freq Offset 0 Hz</p>
Marker	Freq	Pwr									
1	2.401 7 GHz	-2.906 dBm									
2	4.804 5 GHz	-40.494 dBm									
2441 MHz	 <p>Center Freq 13.265000000 GHz</p> <p>Mkr2 4.882 0 GHz -38.085 dBm</p> <table border="1"> <thead> <tr> <th>Marker</th> <th>Freq</th> <th>Pwr</th> </tr> </thead> <tbody> <tr> <td>1</td> <td>2.440 8 GHz</td> <td>-1.640 dBm</td> </tr> <tr> <td>2</td> <td>4.882 0 GHz</td> <td>-38.085 dBm</td> </tr> </tbody> </table>	Marker	Freq	Pwr	1	2.440 8 GHz	-1.640 dBm	2	4.882 0 GHz	-38.085 dBm	<p>Frequency</p> <p>Auto Tune</p> <p>Center Freq 13.265000000 GHz</p> <p>Start Freq 30.000000 MHz</p> <p>Stop Freq 26.500000000 GHz</p> <p>CF Step 2.647000000 GHz</p> <p>Freq Offset 0 Hz</p>
Marker	Freq	Pwr									
1	2.440 8 GHz	-1.640 dBm									
2	4.882 0 GHz	-38.085 dBm									
2480 MHz	 <p>Center Freq 13.265000000 GHz</p> <p>Mkr2 4.960 0 GHz -38.233 dBm</p> <table border="1"> <thead> <tr> <th>Marker</th> <th>Freq</th> <th>Pwr</th> </tr> </thead> <tbody> <tr> <td>1</td> <td>2.475 8 GHz</td> <td>-1.032 dBm</td> </tr> <tr> <td>2</td> <td>4.960 0 GHz</td> <td>-38.233 dBm</td> </tr> </tbody> </table>	Marker	Freq	Pwr	1	2.475 8 GHz	-1.032 dBm	2	4.960 0 GHz	-38.233 dBm	<p>Frequency</p> <p>Auto Tune</p> <p>Center Freq 13.265000000 GHz</p> <p>Start Freq 30.000000 MHz</p> <p>Stop Freq 26.500000000 GHz</p> <p>CF Step 2.647000000 GHz</p> <p>Freq Offset 0 Hz</p>
Marker	Freq	Pwr									
1	2.475 8 GHz	-1.032 dBm									
2	4.960 0 GHz	-38.233 dBm									

Test Item	Out of Band Conducted Emissions Measurement
-----------	---

Mode 4: 8DPSK Continuous TX mode

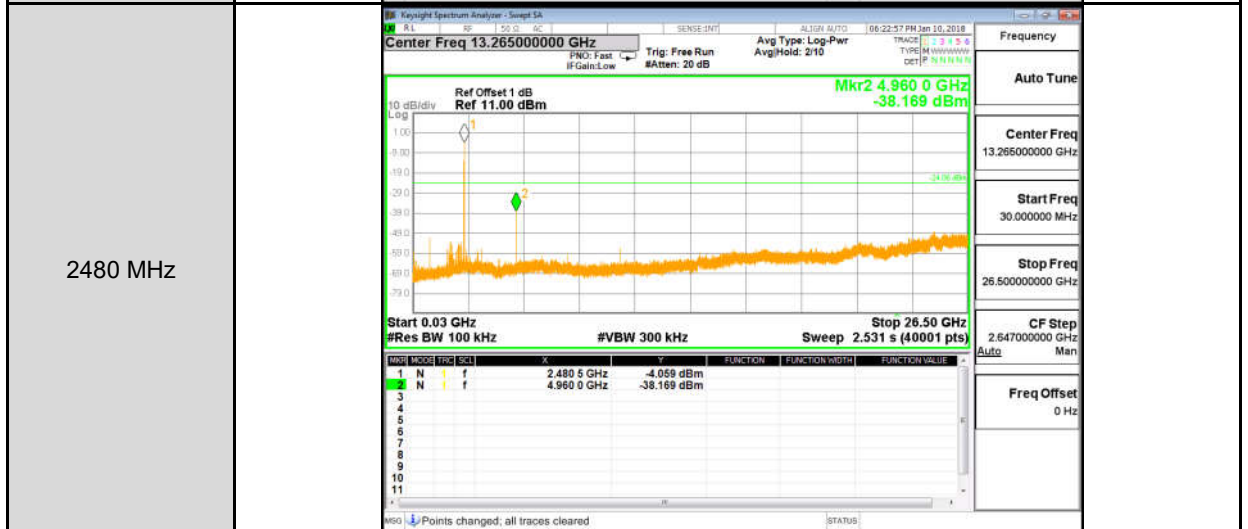



Test Item	Out of Band Conducted Emissions Measurement																	
Mode 2: GFSK Continuous TX mode _ Un-hopping																		
2402 MHz	<p>Center Freq 2.400000000 GHz</p> <p>Mkr2 2.397 376 GHz -54.931 dBm</p> <p>Center 2.400000 GHz #VBW 300 kHz Span 8.000 MHz #Res BW 100 kHz Sweep 1.000 ms (1001 pts)</p> <table border="1"> <thead> <tr> <th>Line</th> <th>Mode</th> <th>Freq</th> <th>Power</th> </tr> </thead> <tbody> <tr> <td>1</td> <td>N</td> <td>2.401 824 GHz</td> <td>-2.145 dBm</td> </tr> <tr> <td>2</td> <td>N</td> <td>2.397 376 GHz</td> <td>-54.931 dBm</td> </tr> </tbody> </table>	Line	Mode	Freq	Power	1	N	2.401 824 GHz	-2.145 dBm	2	N	2.397 376 GHz	-54.931 dBm	<p>Frequency</p> <p>Auto Tune</p> <p>Center Freq 2.400000000 GHz</p> <p>Start Freq 2.396000000 GHz</p> <p>Stop Freq 2.404000000 GHz</p> <p>CF Step 800.000 kHz</p> <p>Freq Offset 0 Hz</p>				
Line	Mode	Freq	Power															
1	N	2.401 824 GHz	-2.145 dBm															
2	N	2.397 376 GHz	-54.931 dBm															
2480 MHz	<p>Center Freq 2.483500000 GHz</p> <p>Mkr2 2.484 692 GHz -53.321 dBm</p> <p>Center 2.483500 GHz #VBW 300 kHz Span 8.000 MHz #Res BW 100 kHz Sweep 1.000 ms (1001 pts)</p> <table border="1"> <thead> <tr> <th>Line</th> <th>Mode</th> <th>Freq</th> <th>Power</th> </tr> </thead> <tbody> <tr> <td>1</td> <td>N</td> <td>2.479 828 GHz</td> <td>0.047 dBm</td> </tr> <tr> <td>2</td> <td>N</td> <td>2.484 692 GHz</td> <td>-53.321 dBm</td> </tr> </tbody> </table>	Line	Mode	Freq	Power	1	N	2.479 828 GHz	0.047 dBm	2	N	2.484 692 GHz	-53.321 dBm	<p>Frequency</p> <p>Auto Tune</p> <p>Center Freq 2.483500000 GHz</p> <p>Start Freq 2.479500000 GHz</p> <p>Stop Freq 2.487500000 GHz</p> <p>CF Step 800.000 kHz</p> <p>Freq Offset 0 Hz</p>				
Line	Mode	Freq	Power															
1	N	2.479 828 GHz	0.047 dBm															
2	N	2.484 692 GHz	-53.321 dBm															
Mode 2: GFSK Continuous TX mode _ Hopping																		
2402 ~ 2480 MHz	<p>Center Freq 2.445000000 GHz</p> <p>Mkr3 2.483 500 00 GHz -63.677 dBm</p> <p>Start 2.39000 GHz #Res BW 100 kHz #VBW 300 kHz Stop 2.50000 GHz Sweep 10.67 ms (40001 pts)</p> <table border="1"> <thead> <tr> <th>Line</th> <th>Mode</th> <th>Freq</th> <th>Power</th> </tr> </thead> <tbody> <tr> <td>1</td> <td>N</td> <td>2.470 830 75 GHz</td> <td>0.515 dBm</td> </tr> <tr> <td>2</td> <td>N</td> <td>2.400 000 00 GHz</td> <td>-51.797 dBm</td> </tr> <tr> <td>3</td> <td>N</td> <td>2.483 500 00 GHz</td> <td>-63.677 dBm</td> </tr> </tbody> </table>	Line	Mode	Freq	Power	1	N	2.470 830 75 GHz	0.515 dBm	2	N	2.400 000 00 GHz	-51.797 dBm	3	N	2.483 500 00 GHz	-63.677 dBm	<p>Frequency</p> <p>Auto Tune</p> <p>Center Freq 2.445000000 GHz</p> <p>Start Freq 2.390000000 GHz</p> <p>Stop Freq 2.500000000 GHz</p> <p>CF Step 11.000000 MHz</p> <p>Freq Offset 0 Hz</p>
Line	Mode	Freq	Power															
1	N	2.470 830 75 GHz	0.515 dBm															
2	N	2.400 000 00 GHz	-51.797 dBm															
3	N	2.483 500 00 GHz	-63.677 dBm															

Test Item	Out of Band Conducted Emissions Measurement																																					
Mode 4: 8DPSK Continuous TX mode _ Un-hopping																																						
2402 MHz	 <p>Center Freq 2.40000000 GHz</p> <p>Mkr2 2.397152 GHz -54.725 dBm</p> <p>Center Freq 2.400000 GHz #VBW 300 kHz Span 8.000 MHz #Res BW 100 kHz Sweep 1.000 ms (1001 pts)</p> <table border="1"> <thead> <tr> <th>MO</th> <th>MODE</th> <th>TRIG</th> <th>ESL</th> <th>F</th> <th>P</th> <th>FUNCTION</th> <th>FUNCTION WIDTH</th> <th>FUNCTION VALUE</th> </tr> </thead> <tbody> <tr> <td>1</td> <td>N</td> <td>f</td> <td></td> <td>2.401824 GHz</td> <td>-2.141 dBm</td> <td></td> <td></td> <td></td> </tr> <tr> <td>2</td> <td>N</td> <td>f</td> <td></td> <td>2.397152 GHz</td> <td>-54.725 dBm</td> <td></td> <td></td> <td></td> </tr> </tbody> </table>	MO	MODE	TRIG	ESL	F	P	FUNCTION	FUNCTION WIDTH	FUNCTION VALUE	1	N	f		2.401824 GHz	-2.141 dBm				2	N	f		2.397152 GHz	-54.725 dBm				<p>Frequency</p> <p>Auto Tune</p> <p>Center Freq 2.40000000 GHz</p> <p>Start Freq 2.396000000 GHz</p> <p>Stop Freq 2.404000000 GHz</p> <p>CF Step 800.000 kHz Man</p> <p>Freq Offset 0 Hz</p>									
MO	MODE	TRIG	ESL	F	P	FUNCTION	FUNCTION WIDTH	FUNCTION VALUE																														
1	N	f		2.401824 GHz	-2.141 dBm																																	
2	N	f		2.397152 GHz	-54.725 dBm																																	
2480 MHz	 <p>Center Freq 2.48350000 GHz</p> <p>Mkr2 2.484524 GHz -53.314 dBm</p> <p>Center Freq 2.483500 GHz #VBW 300 kHz Span 8.000 MHz #Res BW 100 kHz Sweep 1.000 ms (1001 pts)</p> <table border="1"> <thead> <tr> <th>MO</th> <th>MODE</th> <th>TRIG</th> <th>ESL</th> <th>F</th> <th>P</th> <th>FUNCTION</th> <th>FUNCTION WIDTH</th> <th>FUNCTION VALUE</th> </tr> </thead> <tbody> <tr> <td>1</td> <td>N</td> <td>f</td> <td></td> <td>2.479828 GHz</td> <td>0.069 dBm</td> <td></td> <td></td> <td></td> </tr> <tr> <td>2</td> <td>N</td> <td>f</td> <td></td> <td>2.484524 GHz</td> <td>-53.314 dBm</td> <td></td> <td></td> <td></td> </tr> </tbody> </table>	MO	MODE	TRIG	ESL	F	P	FUNCTION	FUNCTION WIDTH	FUNCTION VALUE	1	N	f		2.479828 GHz	0.069 dBm				2	N	f		2.484524 GHz	-53.314 dBm				<p>Frequency</p> <p>Auto Tune</p> <p>Center Freq 2.48350000 GHz</p> <p>Start Freq 2.479500000 GHz</p> <p>Stop Freq 2.487500000 GHz</p> <p>CF Step 800.000 kHz Man</p> <p>Freq Offset 0 Hz</p>									
MO	MODE	TRIG	ESL	F	P	FUNCTION	FUNCTION WIDTH	FUNCTION VALUE																														
1	N	f		2.479828 GHz	0.069 dBm																																	
2	N	f		2.484524 GHz	-53.314 dBm																																	
Mode 4: 8DPSK Continuous TX mode _ Hopping																																						
2402 ~ 2480 MHz	 <p>Center Freq 2.44500000 GHz</p> <p>Mkr3 2.48350000 GHz -64.676 dBm</p> <p>Start 2.39000 GHz #Res BW 100 kHz #VBW 300 kHz Stop 2.50000 GHz Sweep 10.67 ms (40001 pts)</p> <table border="1"> <thead> <tr> <th>MO</th> <th>MODE</th> <th>TRIG</th> <th>ESL</th> <th>F</th> <th>P</th> <th>FUNCTION</th> <th>FUNCTION WIDTH</th> <th>FUNCTION VALUE</th> </tr> </thead> <tbody> <tr> <td>1</td> <td>N</td> <td>f</td> <td></td> <td>2.470839 GHz</td> <td>0.604 dBm</td> <td></td> <td></td> <td></td> </tr> <tr> <td>2</td> <td>N</td> <td>f</td> <td></td> <td>2.400000 GHz</td> <td>-52.319 dBm</td> <td></td> <td></td> <td></td> </tr> <tr> <td>3</td> <td>N</td> <td>f</td> <td></td> <td>2.483500 GHz</td> <td>-64.676 dBm</td> <td></td> <td></td> <td></td> </tr> </tbody> </table>	MO	MODE	TRIG	ESL	F	P	FUNCTION	FUNCTION WIDTH	FUNCTION VALUE	1	N	f		2.470839 GHz	0.604 dBm				2	N	f		2.400000 GHz	-52.319 dBm				3	N	f		2.483500 GHz	-64.676 dBm				<p>Frequency</p> <p>Auto Tune</p> <p>Center Freq 2.44500000 GHz</p> <p>Start Freq 2.390000000 GHz</p> <p>Stop Freq 2.500000000 GHz</p> <p>CF Step 11.000000 MHz Man</p> <p>Freq Offset 0 Hz</p>
MO	MODE	TRIG	ESL	F	P	FUNCTION	FUNCTION WIDTH	FUNCTION VALUE																														
1	N	f		2.470839 GHz	0.604 dBm																																	
2	N	f		2.400000 GHz	-52.319 dBm																																	
3	N	f		2.483500 GHz	-64.676 dBm																																	

## Annex C. Radiated Emission Measurement

### Below 1GHz

Standard:		FCC Part 15.247		Test Distance:		3m	
Test item:		Harmonic		Power:		DC 3.7V	
Test Mode:		Mode 1		Temp.(°C)/Hum.(%RH):		26(°C)/60%RH	
Frequency (MHz)	Reading (dBuV)	Correct Factor (dB/m)	Result (dBuV/m)	Limit (dBuV/m)	Margin (dB)	Remark	Ant.Polar. H / V
55.2207	34.58	-12.29	22.29	40.00	-17.71	QP	H
131.7575	37.05	-12.08	24.97	43.50	-18.53	QP	H
360.4476	32.76	-8.67	24.09	46.00	-21.91	QP	H
520.8881	28.25	-4.99	23.26	46.00	-22.74	QP	H
625.0778	28.47	-3.13	25.34	46.00	-20.66	QP	H
833.3170	27.30	0.59	27.89	46.00	-18.11	QP	H
70.5836	36.88	-13.45	23.43	40.00	-16.57	QP	V
107.5100	40.42	-14.82	25.60	43.50	-17.90	QP	V
432.5457	28.67	-6.19	22.48	46.00	-23.52	QP	V
487.3149	29.65	-5.23	24.42	46.00	-21.58	QP	V
607.7866	28.38	-2.93	25.45	46.00	-20.55	QP	V
827.4932	28.11	0.55	28.66	46.00	-17.34	QP	V

Note:1.Result (dBuV/m) = Correct Factor (dB/m) + Reading(dBuV).

2.Correction factor (dB/m) = Antenna Factor (dB/m) + Cable loss (dB) – Pre-Amplifier gain (dB).

3. When the peak results are less than average limit, so not need to evaluate the average.

**Above 1GHz**

Standard:	FCC Part 15.247	Test Distance:	3m
Test item:	Harmonic	Power:	DC 3.7V
Frequency:	2402MHz	Temp.(°C)/Hum.(%RH):	26(°C)/60%RH
Mode:	Mode 2	Ant.Polar.:	Horizontal

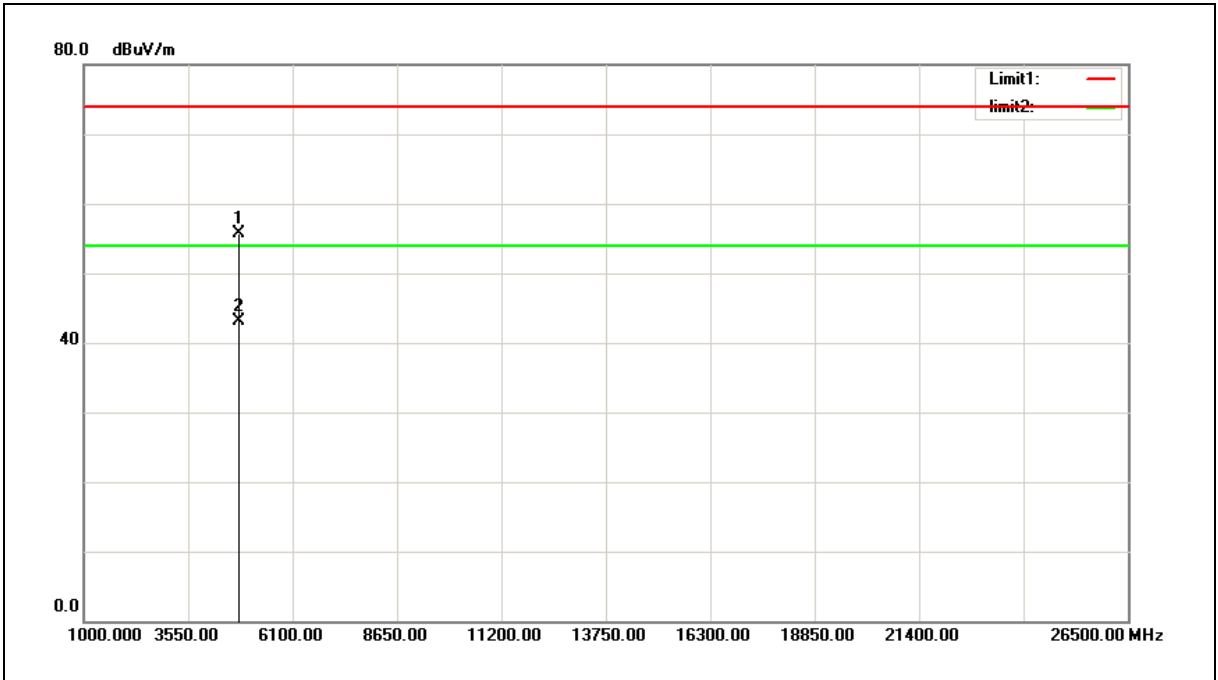

No.	Frequency (MHz)	Reading (dBuV)	Correct Factor (dB/m)	Result (dBuV/m)	Limit (dBuV/m)	Margin (dB)	Remark
1	4804.000	60.14	-4.35	55.79	74.00	-18.21	peak
2	4804.000	47.42	-4.35	43.07	54.00	-10.93	AVG

Note:1.Result (dBuV/m) = Correct Factor (dB/m) + Reading(dBuV).

2.Correction factor (dB/m) = Antenna Factor (dB/m) + Cable loss (dB) – Pre-Amplifier gain (dB).

3. When the peak results are less than average limit, so not need to evaluate the average.

Standard:	FCC Part 15.247	Test Distance:	3m
Test item:	Harmonic	Power:	DC 3.7V
Frequency:	2402MHz	Temp.(°C)/Hum.(%RH):	26(°C)/60%RH
Mode:	Mode 2	Ant.Polar.:	Vertical

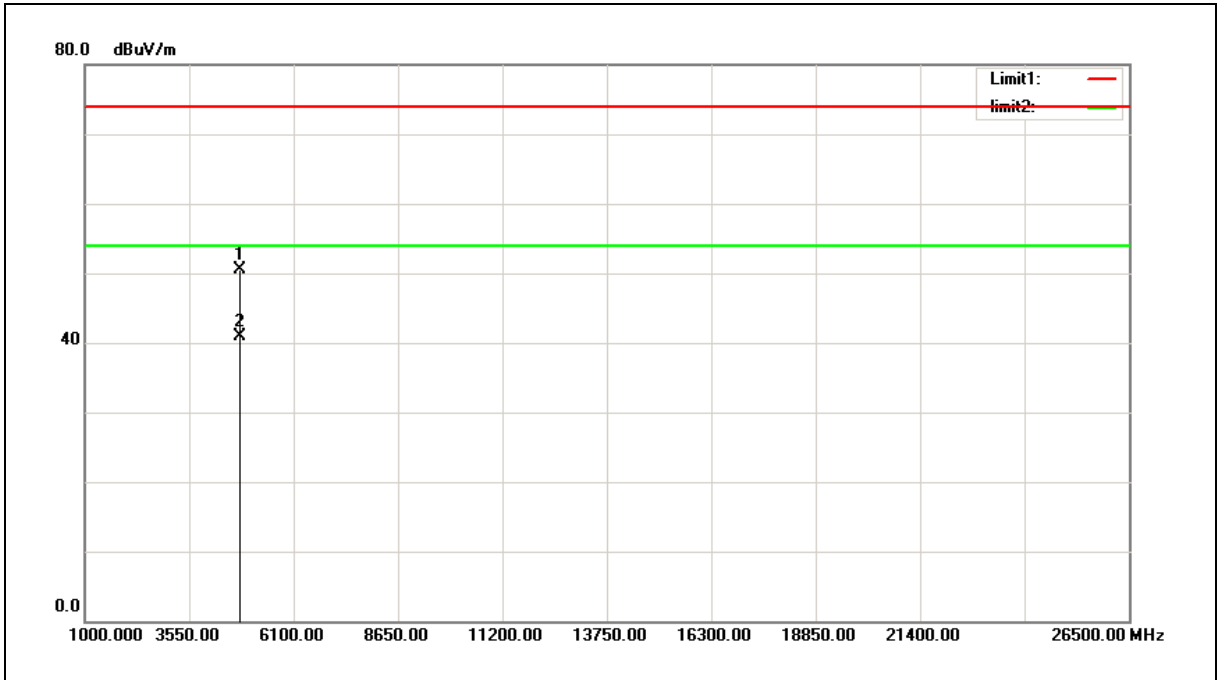

No.	Frequency (MHz)	Reading (dBuV)	Correct Factor (dB/m)	Result (dBuV/m)	Limit (dBuV/m)	Margin (dB)	Remark
1	4804.000	54.86	-4.35	50.51	74.00	-23.49	peak
2	4804.000	45.31	-4.35	40.96	54.00	-13.04	AVG

Note:1.Result (dBuV/m) = Correct Factor (dB/m) + Reading(dBuV).

2.Correction factor (dB/m) = Antenna Factor (dB/m) + Cable loss (dB) – Pre-Amplifier gain (dB).

3. When the peak results are less than average limit, so not need to evaluate the average.

Standard:	FCC Part 15.247	Test Distance:	3m
Test item:	Harmonic	Power:	DC 3.7V
Frequency:	2441MHz	Temp.(°C)/Hum.(%RH):	26(°C)/60%RH
Mode:	Mode 2	Ant.Polar.:	Horizontal

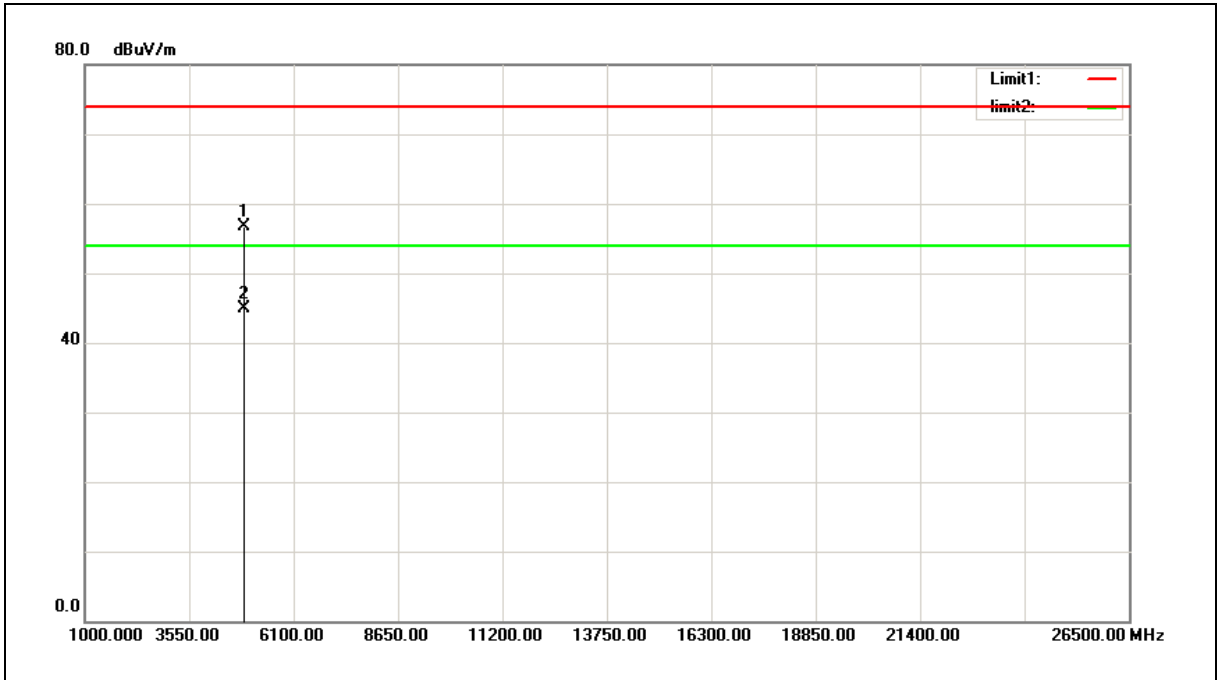

No.	Frequency (MHz)	Reading (dBuV)	Correct Factor (dB/m)	Result (dBuV/m)	Limit (dBuV/m)	Margin (dB)	Remark
1	4882.000	60.98	-4.37	56.61	74.00	-17.39	peak
2	4882.000	49.26	-4.37	44.89	54.00	-9.11	AVG

Note:1.Result (dBuV/m) = Correct Factor (dB/m) + Reading(dBuV).

2.Correction factor (dB/m) = Antenna Factor (dB/m) + Cable loss (dB) – Pre-Amplifier gain (dB).

3. When the peak results are less than average limit, so not need to evaluate the average.

Standard:	FCC Part 15.247	Test Distance:	3m
Test item:	Harmonic	Power:	DC 3.7V
Frequency:	2441MHz	Temp.(°C)/Hum.(%RH):	26(°C)/60%RH
Mode:	Mode 2	Ant.Polar.:	Vertical

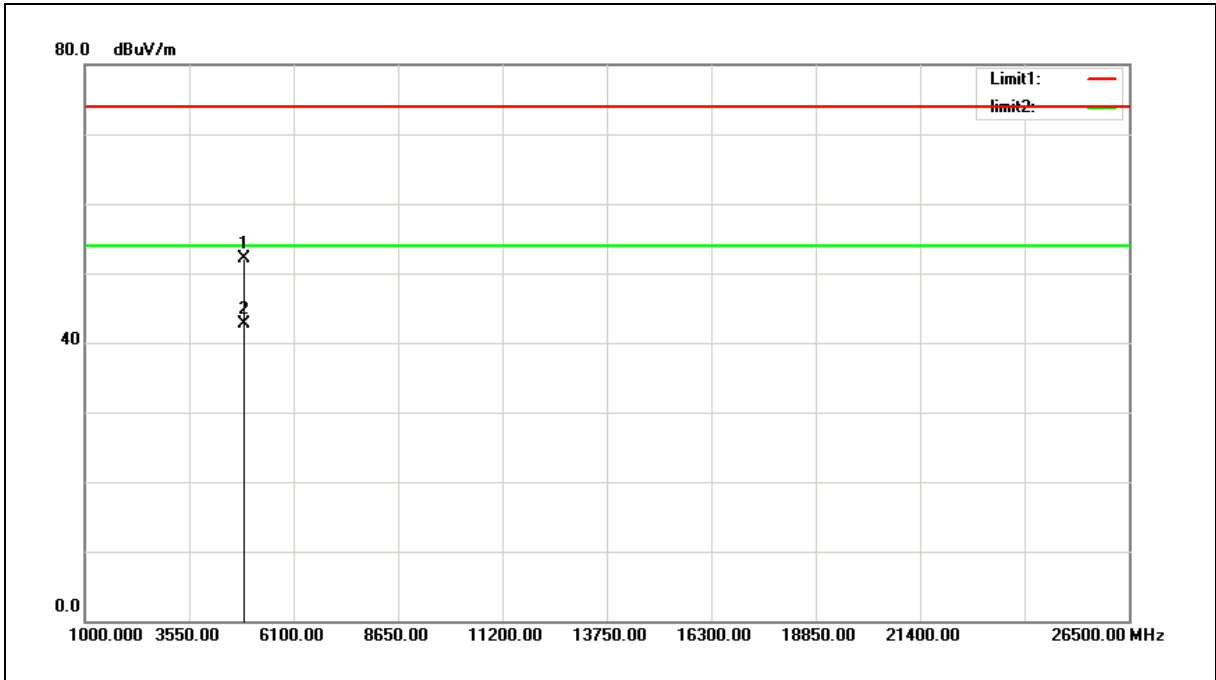

No.	Frequency (MHz)	Reading (dBuV)	Correct Factor (dB/m)	Result (dBuV/m)	Limit (dBuV/m)	Margin (dB)	Remark
1	4882.000	56.43	-4.37	52.06	74.00	-21.94	peak
2	4882.000	47.11	-4.37	42.74	54.00	-11.26	AVG

Note:1.Result (dBuV/m) = Correct Factor (dB/m) + Reading(dBuV).

2.Correction factor (dB/m) = Antenna Factor (dB/m) + Cable loss (dB) – Pre-Amplifier gain (dB).

3. When the peak results are less than average limit, so not need to evaluate the average.

Standard:	FCC Part 15.247	Test Distance:	3m
Test item:	Harmonic	Power:	DC 3.7V
Frequency:	2480MHz	Temp.(°C)/Hum.(%RH):	26(°C)/60%RH
Mode:	Mode 2	Ant.Polar.:	Horizontal

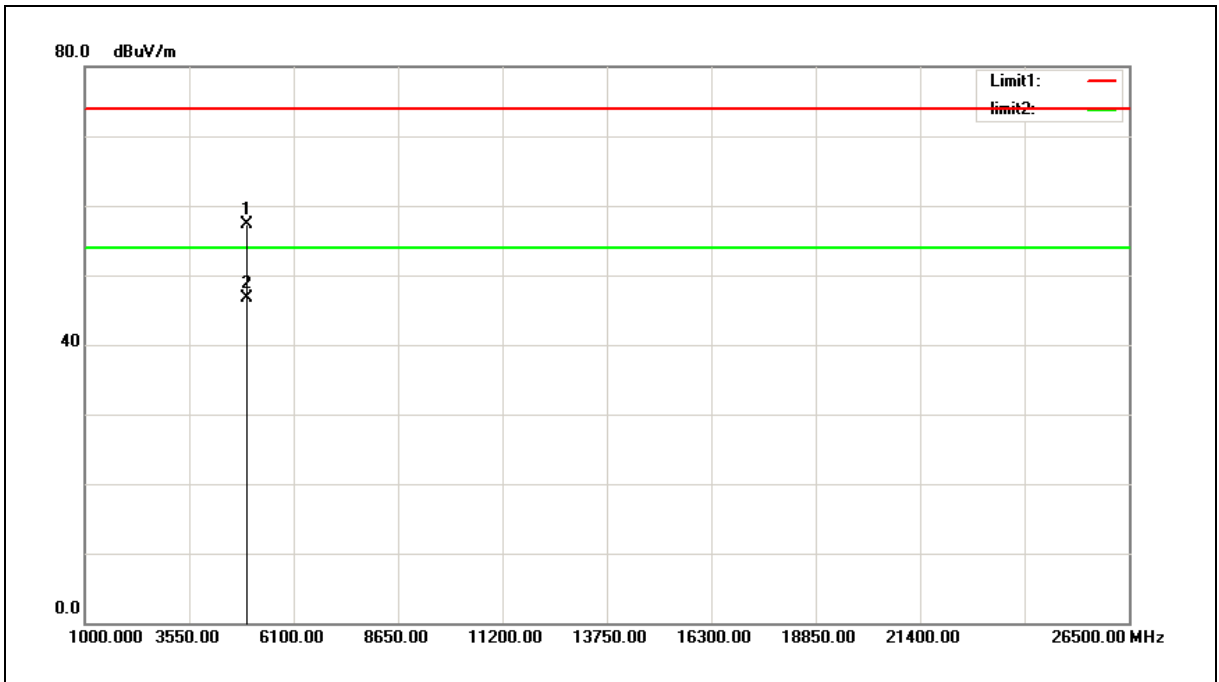

No.	Frequency (MHz)	Reading (dBuV)	Correct Factor (dB/m)	Result (dBuV/m)	Limit (dBuV/m)	Margin (dB)	Remark
1	4960.000	61.68	-4.39	57.29	74.00	-16.71	peak
2	4960.000	50.99	-4.39	46.60	54.00	-7.40	AVG

Note:1.Result (dBuV/m) = Correct Factor (dB/m) + Reading(dBuV).

2.Correction factor (dB/m) = Antenna Factor (dB/m) + Cable loss (dB) – Pre-Amplifier gain (dB).

3. When the peak results are less than average limit, so not need to evaluate the average.



Standard:	FCC Part 15.247	Test Distance:	3m
Test item:	Harmonic	Power:	DC 3.7V
Frequency:	2480MHz	Temp.(°C)/Hum.(%RH):	26(°C)/60%RH
Mode:	Mode 2	Ant.Polar.:	Vertical

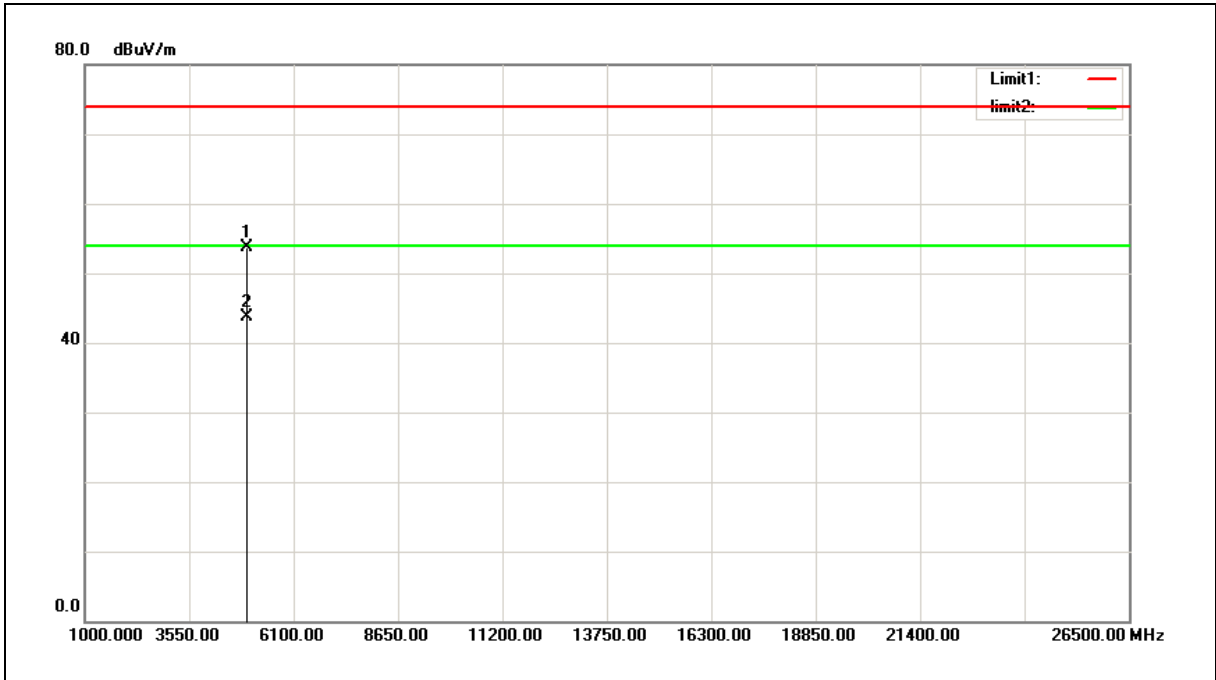

No.	Frequency (MHz)	Reading (dBuV)	Correct Factor (dB/m)	Result (dBuV/m)	Limit (dBuV/m)	Margin (dB)	Remark
1	4960.000	58.19	-4.39	53.80	74.00	-20.20	peak
2	4960.000	48.14	-4.39	43.75	54.00	-10.25	AVG

Note:1.Result (dBuV/m) = Correct Factor (dB/m) + Reading(dBuV).

2.Correction factor (dB/m) = Antenna Factor (dB/m) + Cable loss (dB) – Pre-Amplifier gain (dB).

3. When the peak results are less than average limit, so not need to evaluate the average.

Standard:	FCC Part 15.247	Test Distance:	3m
Test item:	Harmonic	Power:	DC 3.7V
Frequency:	2402MHz	Temp.(°C)/Hum.(%RH):	26(°C)/60%RH
Mode:	Mode 4	Ant.Polar.:	Horizontal

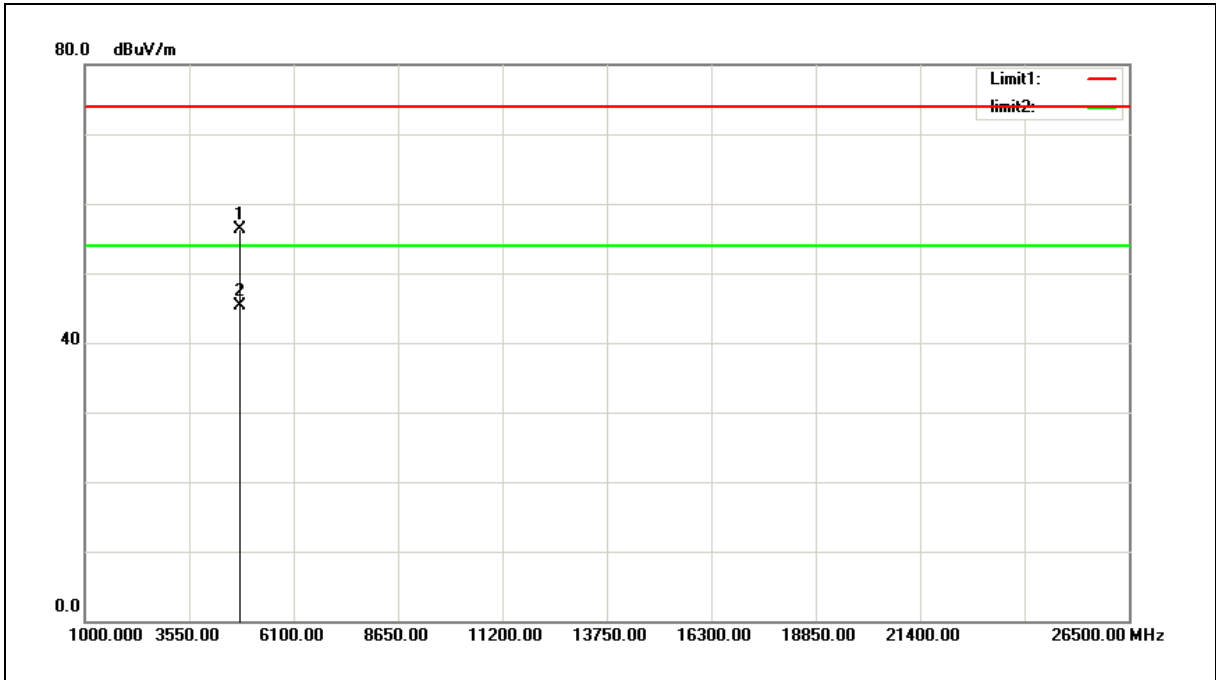

No.	Frequency (MHz)	Reading (dBuV)	Correct Factor (dB/m)	Result (dBuV/m)	Limit (dBuV/m)	Margin (dB)	Remark
1	4804.000	60.64	-4.35	56.29	74.00	-17.71	peak
2	4804.000	49.73	-4.35	45.38	54.00	-8.62	AVG

Note:1.Result (dBuV/m) = Correct Factor (dB/m) + Reading(dBuV).

2.Correction factor (dB/m) = Antenna Factor (dB/m) + Cable loss (dB) – Pre-Amplifier gain (dB).

3. When the peak results are less than average limit, so not need to evaluate the average.

Standard:	FCC Part 15.247	Test Distance:	3m
Test item:	Harmonic	Power:	DC 3.7V
Frequency:	2402MHz	Temp.(°C)/Hum.(%RH):	26(°C)/60%RH
Mode:	Mode 4	Ant.Polar.:	Vertical

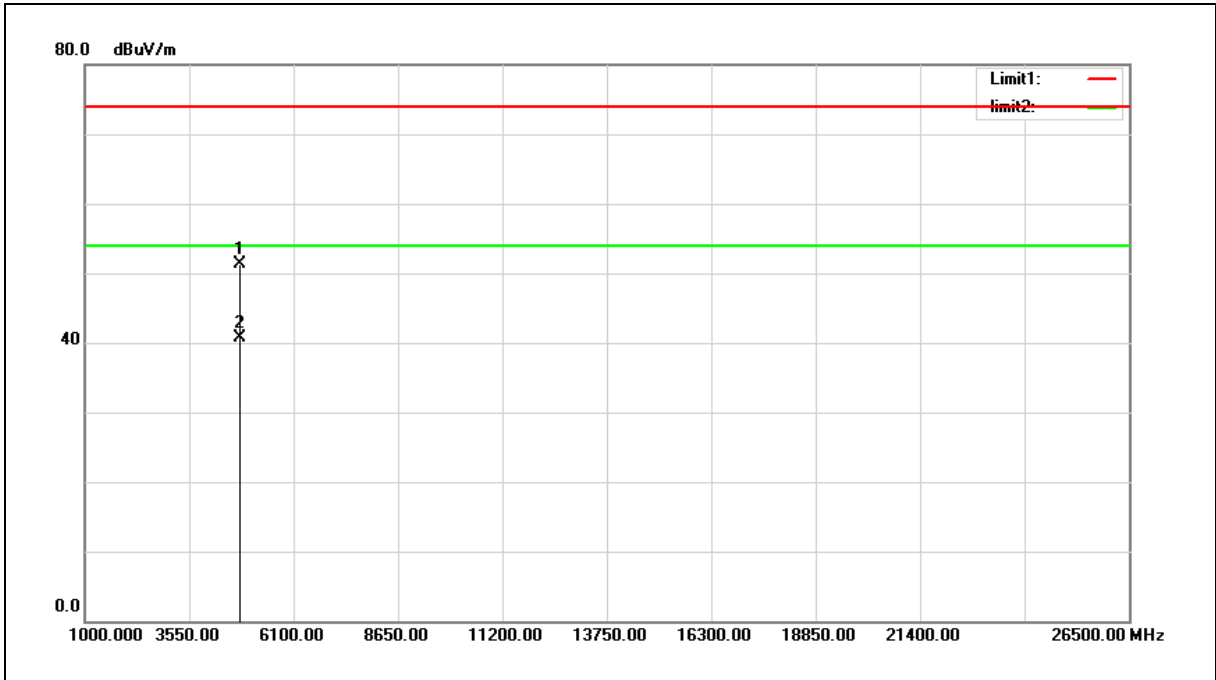

No.	Frequency (MHz)	Reading (dBuV)	Correct Factor (dB/m)	Result (dBuV/m)	Limit (dBuV/m)	Margin (dB)	Remark
1	4804.000	55.72	-4.35	51.37	74.00	-22.63	peak
2	4804.000	44.98	-4.35	40.63	54.00	-13.37	AVG

Note:1.Result (dBuV/m) = Correct Factor (dB/m) + Reading(dBuV).

2.Correction factor (dB/m) = Antenna Factor (dB/m) + Cable loss (dB) – Pre-Amplifier gain (dB).

3. When the peak results are less than average limit, so not need to evaluate the average.

Standard:	FCC Part 15.247	Test Distance:	3m
Test item:	Harmonic	Power:	DC 3.7V
Frequency:	2441MHz	Temp.(°C)/Hum.(%RH):	26(°C)/60%RH
Mode:	Mode 4	Ant.Polar.:	Horizontal

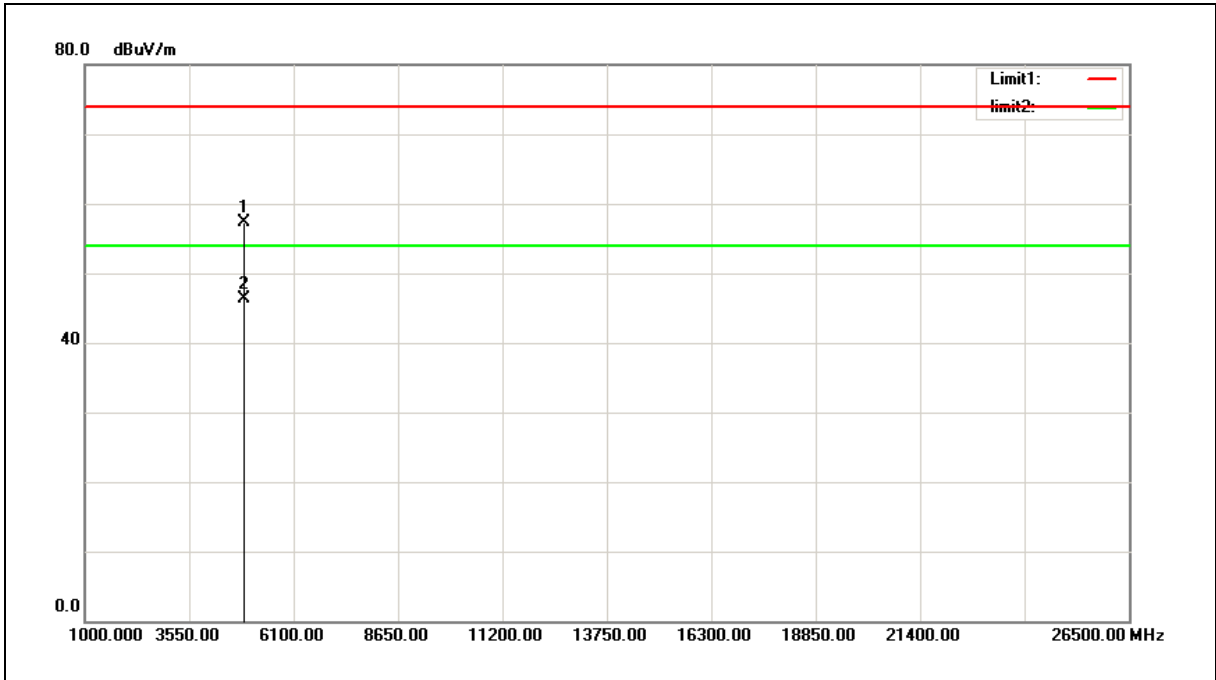

No.	Frequency (MHz)	Reading (dBuV)	Correct Factor (dB/m)	Result (dBuV/m)	Limit (dBuV/m)	Margin (dB)	Remark
1	4882.000	61.68	-4.37	57.31	74.00	-16.69	peak
2	4882.000	50.65	-4.37	46.28	54.00	-7.72	AVG

Note:1.Result (dBuV/m) = Correct Factor (dB/m) + Reading(dBuV).

2.Correction factor (dB/m) = Antenna Factor (dB/m) + Cable loss (dB) – Pre-Amplifier gain (dB).

3. When the peak results are less than average limit, so not need to evaluate the average.

Standard:	FCC Part 15.247	Test Distance:	3m
Test item:	Harmonic	Power:	DC 3.7V
Frequency:	2441MHz	Temp.(°C)/Hum.(%RH):	26(°C)/60%RH
Mode:	Mode 4	Ant.Polar.:	Vertical

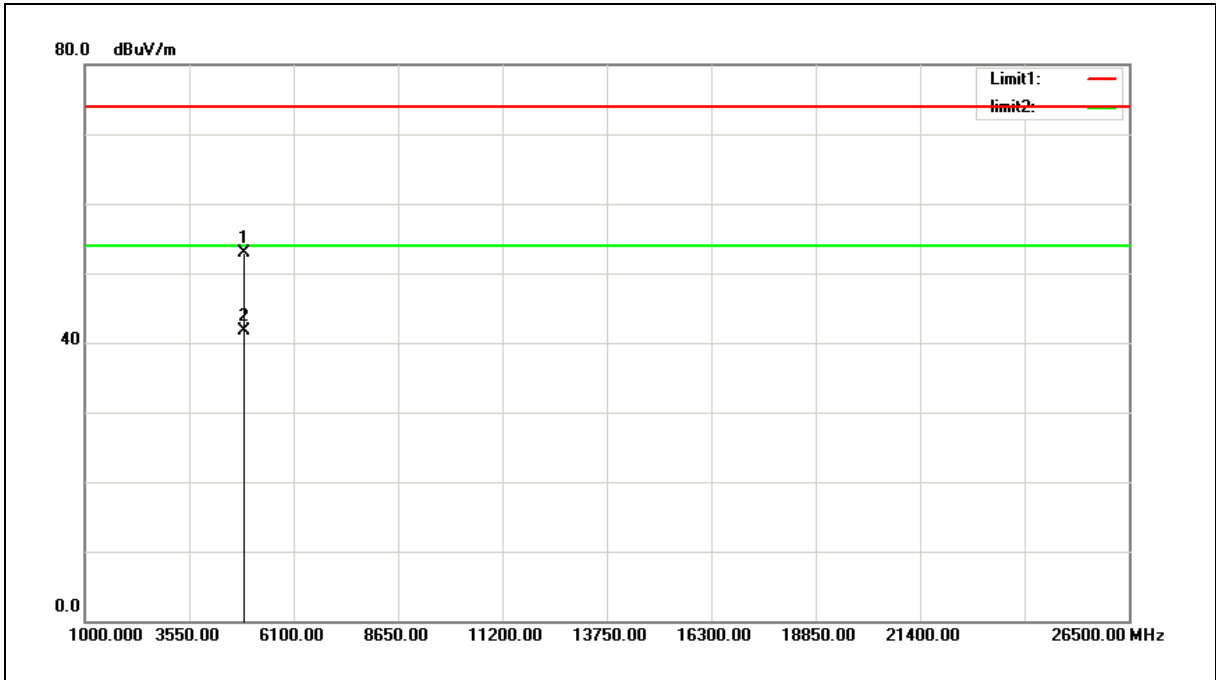

No.	Frequency (MHz)	Reading (dBuV)	Correct Factor (dB/m)	Result (dBuV/m)	Limit (dBuV/m)	Margin (dB)	Remark
1	4882.000	57.26	-4.37	52.89	74.00	-21.11	peak
2	4882.000	46.13	-4.37	41.76	54.00	-12.24	AVG

Note:1.Result (dBuV/m) = Correct Factor (dB/m) + Reading(dBuV).

2.Correction factor (dB/m) = Antenna Factor (dB/m) + Cable loss (dB) – Pre-Amplifier gain (dB).

3. When the peak results are less than average limit, so not need to evaluate the average.

Standard:	FCC Part 15.247	Test Distance:	3m
Test item:	Harmonic	Power:	DC 3.7V
Frequency:	2480MHz	Temp.(°C)/Hum.(%RH):	26(°C)/60%RH
Mode:	Mode 4	Ant.Polar.:	Horizontal

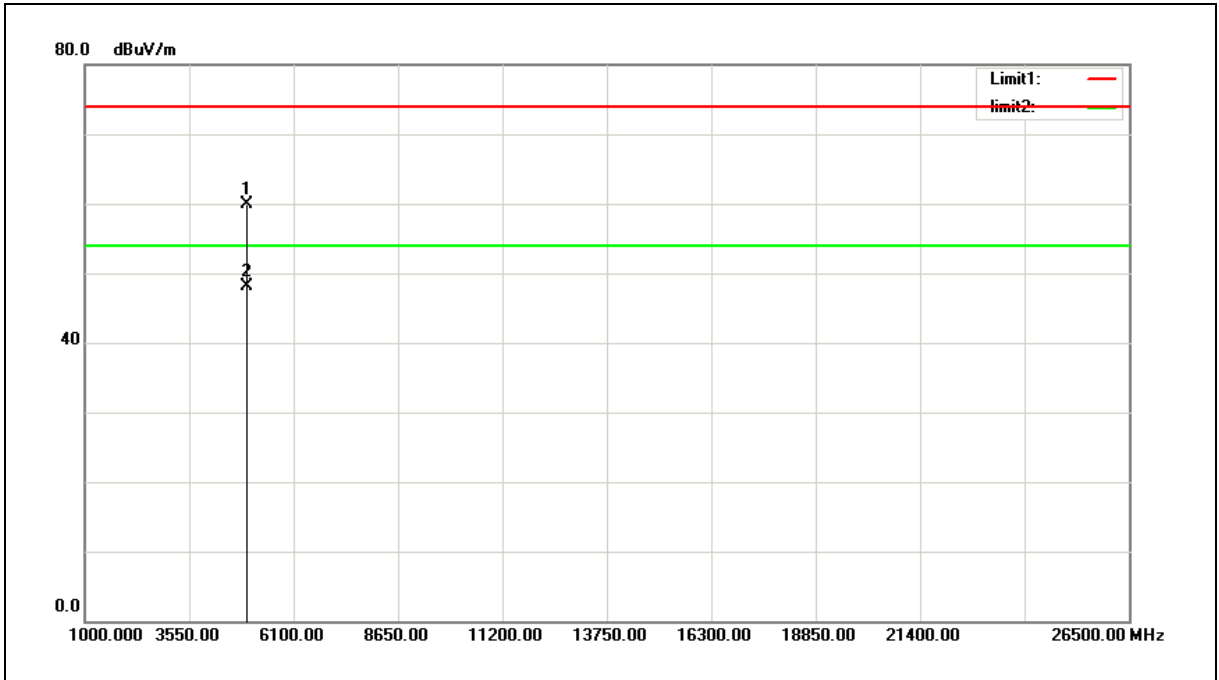

No.	Frequency (MHz)	Reading (dBuV)	Correct Factor (dB/m)	Result (dBuV/m)	Limit (dBuV/m)	Margin (dB)	Remark
1	4960.000	64.21	-4.39	59.82	74.00	-14.18	peak
2	4960.000	52.58	-4.39	48.19	54.00	-5.81	AVG

Note:1.Result (dBuV/m) = Correct Factor (dB/m) + Reading(dBuV).

2.Correction factor (dB/m) = Antenna Factor (dB/m) + Cable loss (dB) – Pre-Amplifier gain (dB).

3. When the peak results are less than average limit, so not need to evaluate the average.

Standard:	FCC Part 15.247	Test Distance:	3m
Test item:	Harmonic	Power:	DC 3.7V
Frequency:	2480MHz	Temp.(°C)/Hum.(%RH):	26(°C)/60%RH
Mode:	Mode 4	Ant.Polar.:	Vertical

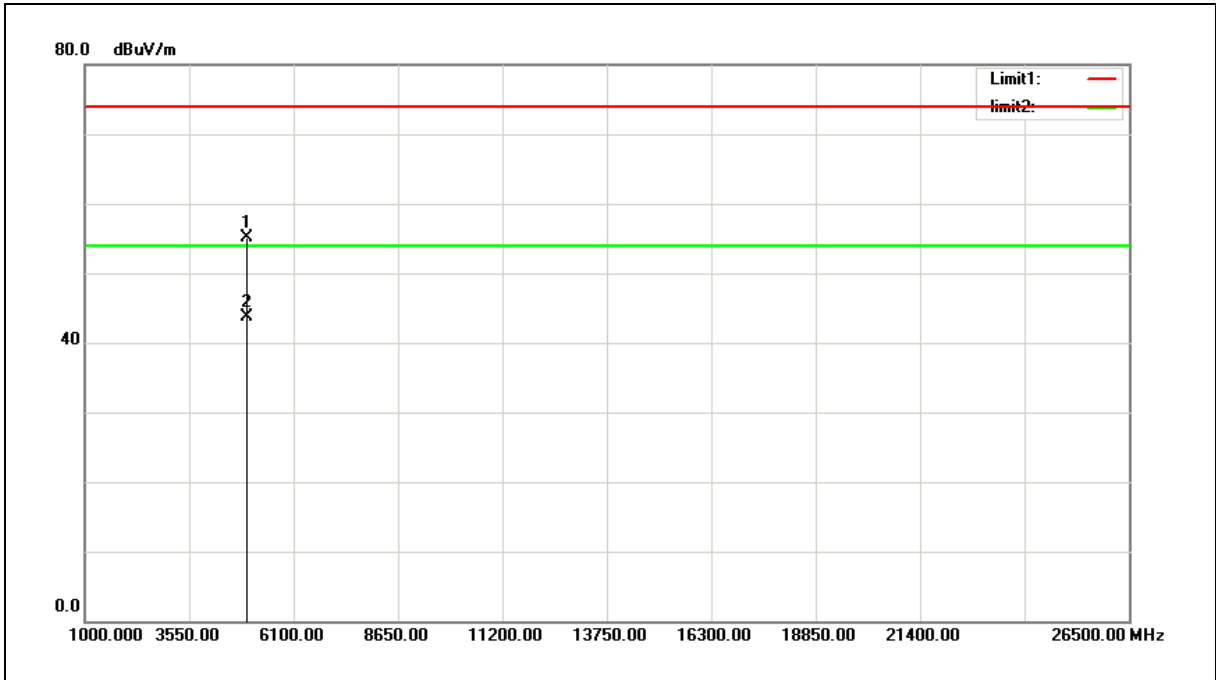

No.	Frequency (MHz)	Reading (dBuV)	Correct Factor (dB/m)	Result (dBuV/m)	Limit (dBuV/m)	Margin (dB)	Remark
1	4960.000	59.47	-4.39	55.08	74.00	-18.92	peak
2	4960.000	48.09	-4.39	43.70	54.00	-10.30	AVG

Note:1.Result (dBuV/m) = Correct Factor (dB/m) + Reading(dBuV).

2.Correction factor (dB/m) = Antenna Factor (dB/m) + Cable loss (dB) – Pre-Amplifier gain (dB).

3. When the peak results are less than average limit, so not need to evaluate the average.

**Band Edge**

Standard:	FCC Part 15.247	Test Distance:	3m
Test item:	Band edge	Power:	DC 3.7V
Frequency:	2402MHz	Temp.(°C)/Hum.(%RH):	26(°C)/60%RH
Mode:	Mode 2	Ant.Polar.:	Horizontal

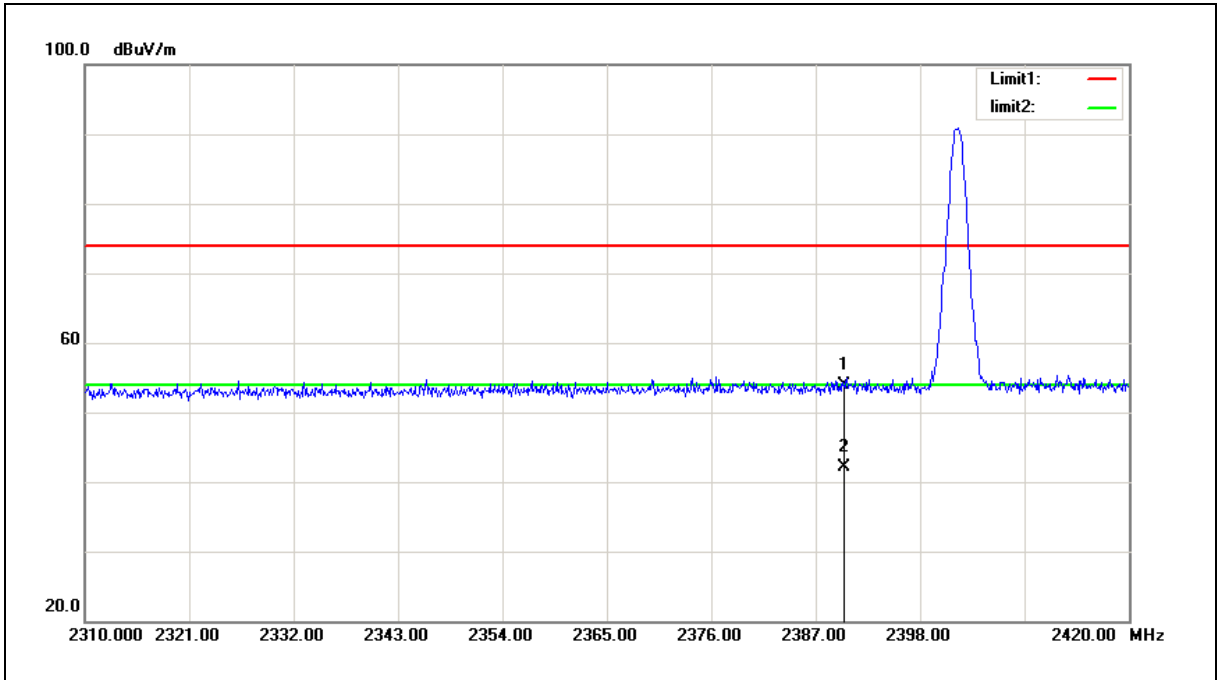

No.	Frequency (MHz)	Reading (dBuV)	Correct Factor (dB/m)	Result (dBuV/m)	Limit (dBuV/m)	Margin (dB)	Remark
1	2390.000	14.58	39.41	53.99	74.00	-20.01	peak
2	2390.000	2.62	39.41	42.03	54.00	-11.97	AVG

Note:1.Result (dBuV/m) = Correct Factor (dB/m) + Reading(dBuV).

2.Correction factor (dB/m) = Antenna Factor (dB/m) + Cable loss (dB) – Pre-Amplifier gain (dB).

3. When the peak results are less than average limit, so not need to evaluate the average.



Standard:	FCC Part 15.247	Test Distance:	3m
Test item:	Band edge	Power:	DC 3.7V
Frequency:	2402MHz	Temp.(°C)/Hum.(%RH):	26(°C)/60%RH
Mode:	Mode 2	Ant.Polar.:	Vertical

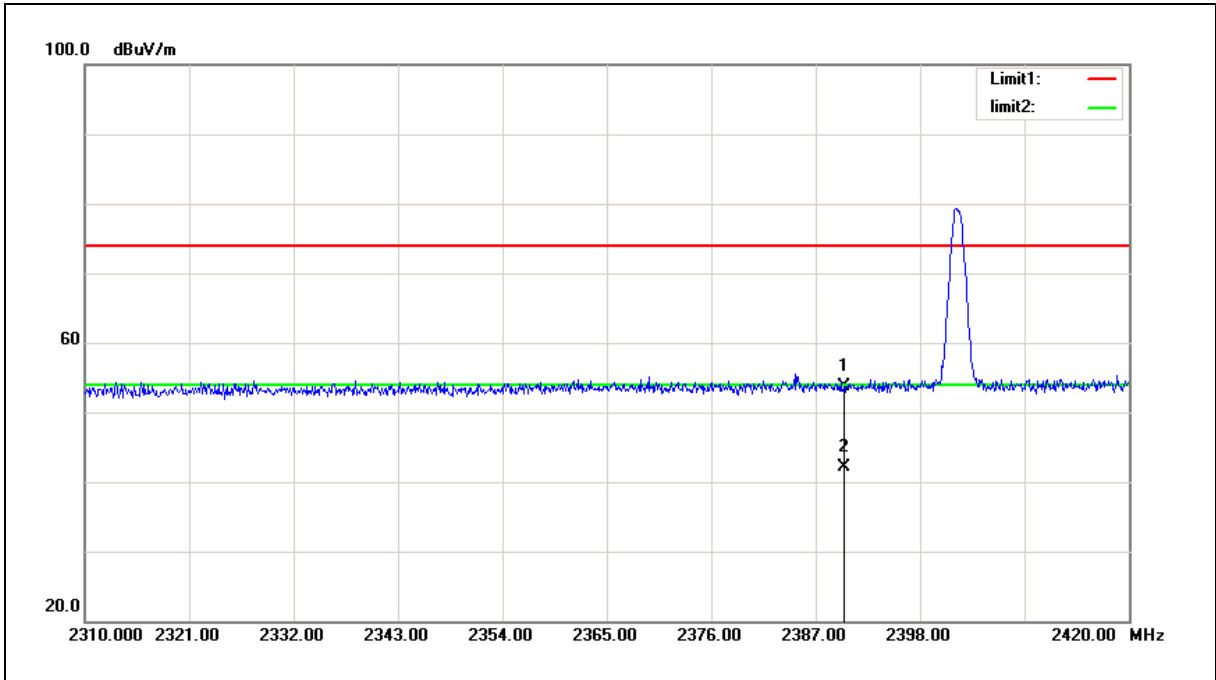

No.	Frequency (MHz)	Reading (dBuV)	Correct Factor (dB/m)	Result (dBuV/m)	Limit (dBuV/m)	Margin (dB)	Remark
1	2390.000	14.32	39.41	53.73	74.00	-20.27	peak
2	2390.000	2.63	39.41	42.04	54.00	-11.96	AVG

Note:1.Result (dBuV/m) = Correct Factor (dB/m) + Reading(dBuV).

2.Correction factor (dB/m) = Antenna Factor (dB/m) + Cable loss (dB) – Pre-Amplifier gain (dB).

3. When the peak results are less than average limit, so not need to evaluate the average.

Standard:	FCC Part 15.247	Test Distance:	3m
Test item:	Band edge	Power:	DC 3.7V
Frequency:	2480MHz	Temp.(°C)/Hum.(%RH):	26(°C)/60%RH
Mode:	Mode 2	Ant.Polar.:	Horizontal

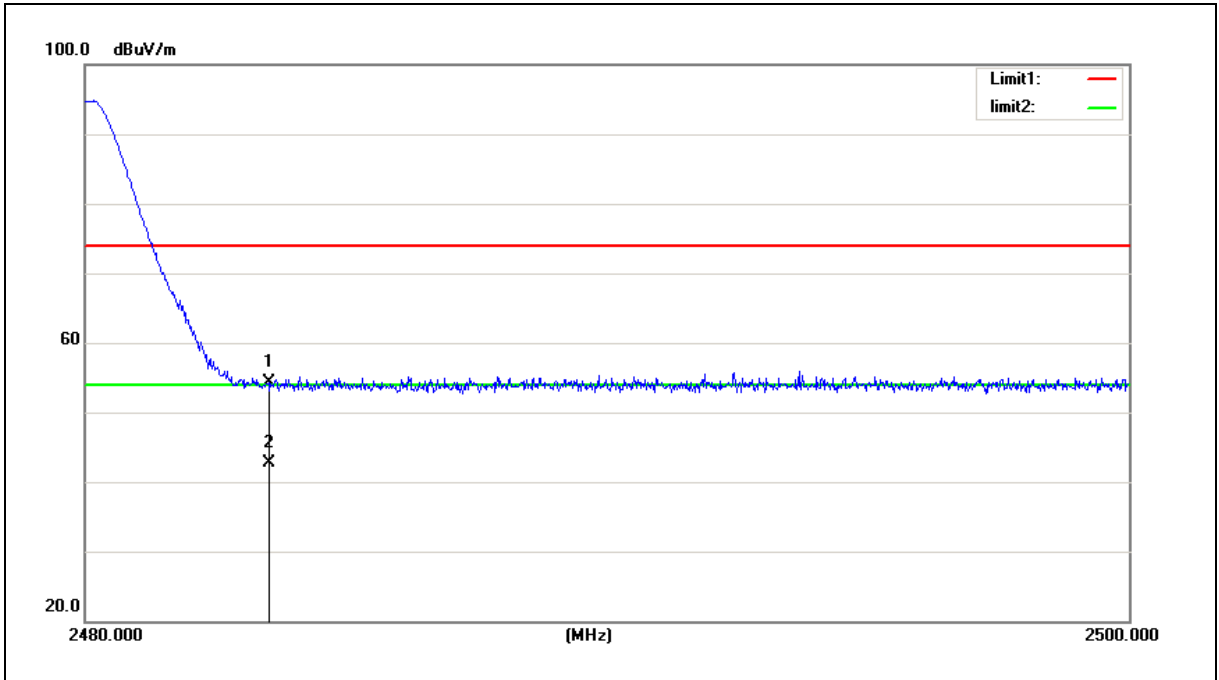

No.	Frequency (MHz)	Reading (dBuV)	Correct Factor (dB/m)	Result (dBuV/m)	Limit (dBuV/m)	Margin (dB)	Remark
1	2483.500	14.42	39.83	54.25	74.00	-19.75	peak
2	2483.500	2.78	39.83	42.61	54.00	-11.39	AVG

Note:1.Result (dBuV/m) = Correct Factor (dB/m) + Reading(dBuV).

2.Correction factor (dB/m) = Antenna Factor (dB/m) + Cable loss (dB) – Pre-Amplifier gain (dB).

3. When the peak results are less than average limit, so not need to evaluate the average.

Standard:	FCC Part 15.247	Test Distance:	3m
Test item:	Band edge	Power:	DC 3.7V
Frequency:	2480MHz	Temp.(°C)/Hum.(%RH):	26(°C)/60%RH
Mode:	Mode 2	Ant.Polar.:	Vertical

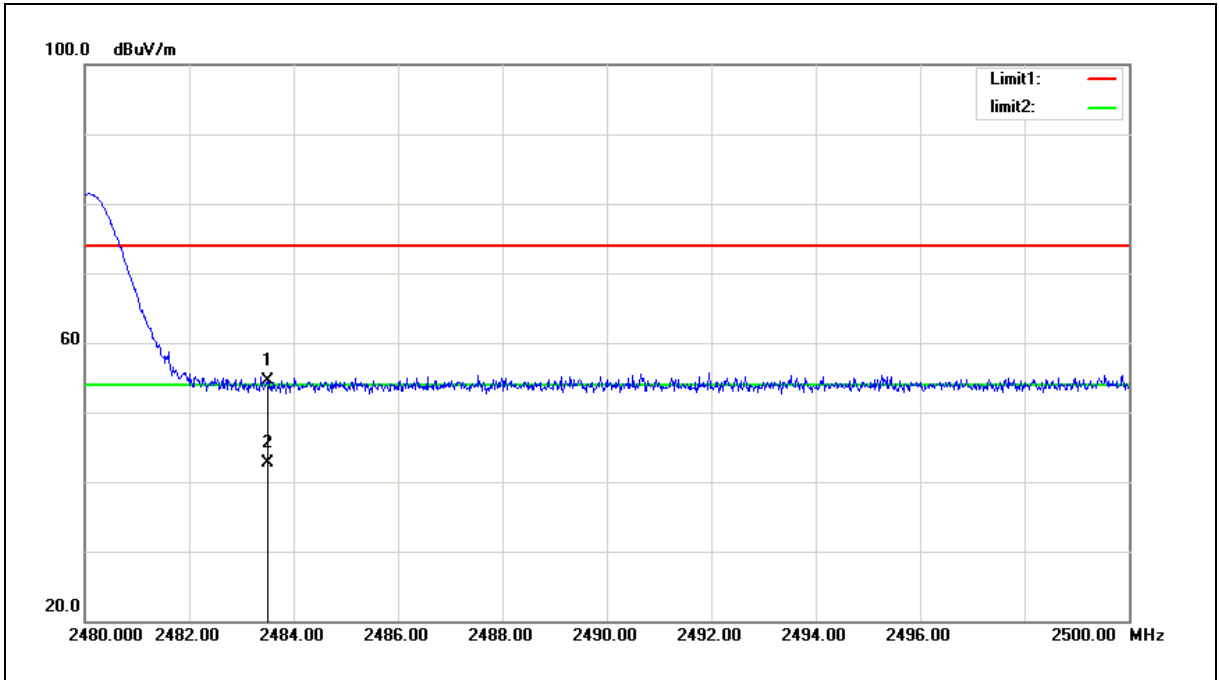

No.	Frequency (MHz)	Reading (dBuV)	Correct Factor (dB/m)	Result (dBuV/m)	Limit (dBuV/m)	Margin (dB)	Remark
1	2483.500	14.75	39.83	54.58	74.00	-19.42	peak
2	2483.500	2.78	39.83	42.61	54.00	-11.39	AVG

Note:1.Result (dBuV/m) = Correct Factor (dB/m) + Reading(dBuV).

2.Correction factor (dB/m) = Antenna Factor (dB/m) + Cable loss (dB) – Pre-Amplifier gain (dB).

3. When the peak results are less than average limit, so not need to evaluate the average.

Standard:	FCC Part 15.247	Test Distance:	3m
Test item:	Band edge	Power:	DC 3.7V
Frequency:	hopping	Temp.(°C)/Hum.(%RH):	26(°C)/60%RH
Mode:	Mode 2	Ant.Polar.:	Horizontal

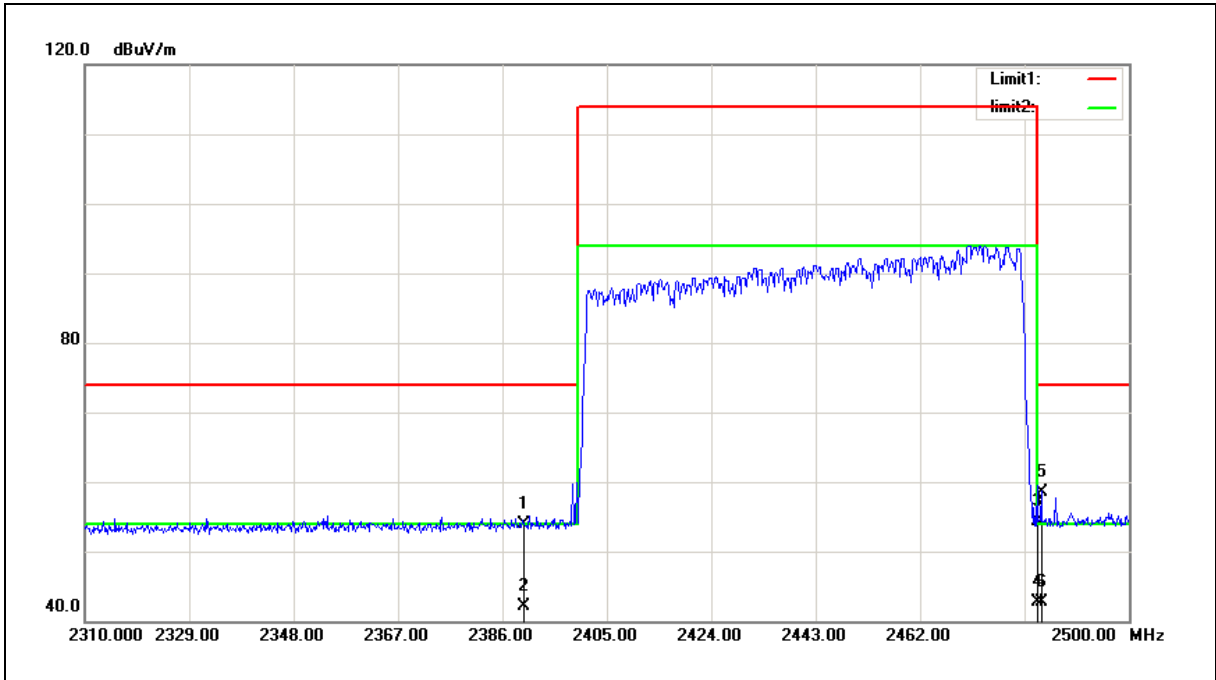

No.	Frequency (MHz)	Reading (dBuV)	Correct Factor (dB/m)	Result (dBuV/m)	Limit (dBuV/m)	Margin (dB)	Remark
1	2390.000	14.42	39.41	53.83	74.00	-20.17	peak
2	2390.000	2.64	39.41	42.05	54.00	-11.95	AVG
3	2483.500	14.39	39.83	54.22	74.00	-19.78	peak
4	2483.500	2.78	39.83	42.61	54.00	-11.39	AVG
5	2484.045	18.77	39.83	58.60	74.00	-15.40	peak
6	2484.045	2.78	39.83	42.61	54.00	-11.39	AVG

Note:1.Result (dBuV/m) = Correct Factor (dB/m) + Reading(dBuV).

2.Correction factor (dB/m) = Antenna Factor (dB/m) + Cable loss (dB) – Pre-Amplifier gain (dB).

3. When the peak results are less than average limit, so not need to evaluate the average.

Standard:	FCC Part 15.247	Test Distance:	3m
Test item:	Band edge	Power:	DC 3.7V
Frequency:	hopping	Temp.(°C)/Hum.(%RH):	26(°C)/60%RH
Mode:	Mode 2	Ant.Polar.:	Vertical

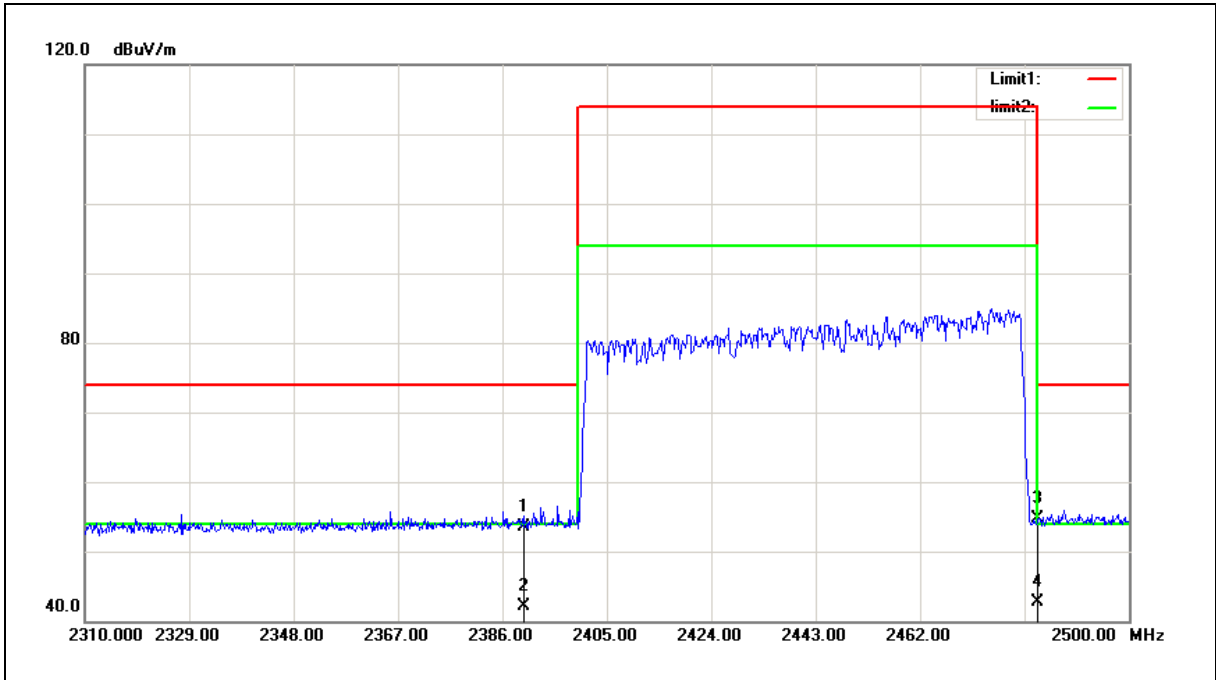

No.	Frequency (MHz)	Reading (dBuV)	Correct Factor (dB/m)	Result (dBuV/m)	Limit (dBuV/m)	Margin (dB)	Remark
1	2390.000	14.00	39.41	53.41	74.00	-20.59	peak
2	2390.000	2.64	39.41	42.05	54.00	-11.95	AVG
3	2483.500	14.91	39.83	54.74	74.00	-19.26	peak
4	2483.500	2.78	39.83	42.61	54.00	-11.39	AVG

Note:1.Result (dBuV/m) = Correct Factor (dB/m) + Reading(dBuV).

2.Correction factor (dB/m) = Antenna Factor (dB/m) + Cable loss (dB) – Pre-Amplifier gain (dB).

3. When the peak results are less than average limit, so not need to evaluate the average.

Standard:	FCC Part 15.247	Test Distance:	3m
Test item:	Band edge	Power:	DC 3.7V
Frequency:	2402MHz	Temp.(°C)/Hum.(%RH):	26(°C)/60%RH
Mode:	Mode 4	Ant.Polar.:	Horizontal

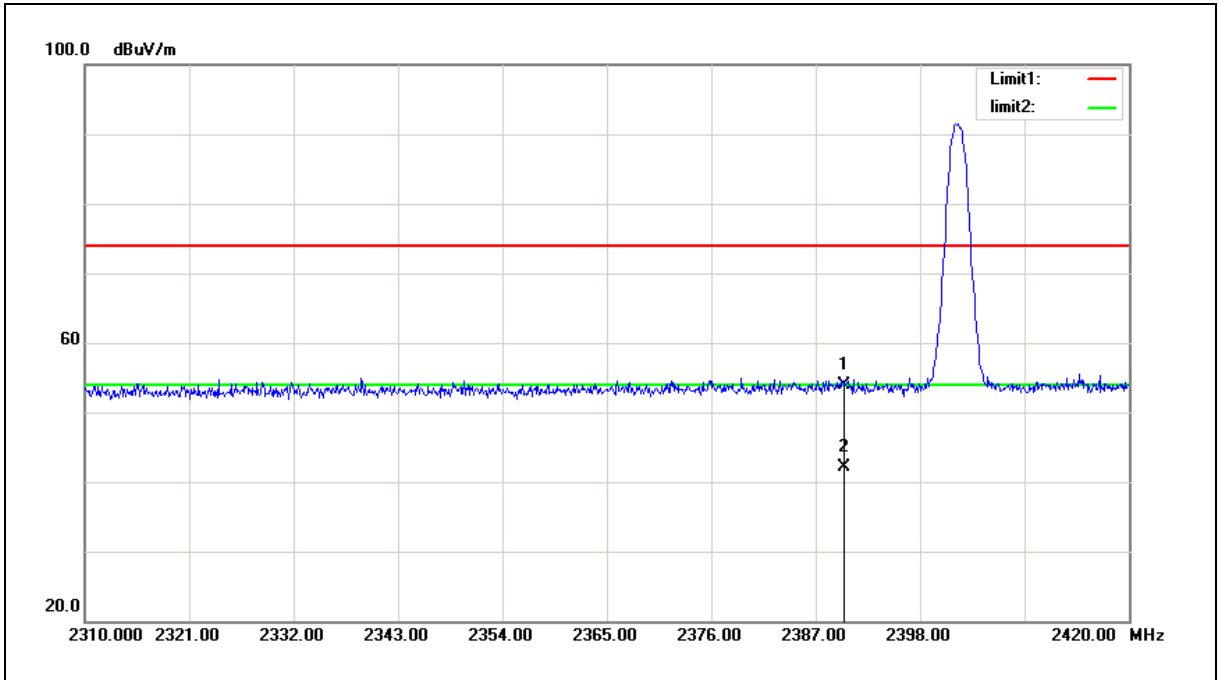

No.	Frequency (MHz)	Reading (dBuV)	Correct Factor (dB/m)	Result (dBuV/m)	Limit (dBuV/m)	Margin (dB)	Remark
1	2390.000	14.53	39.41	53.94	74.00	-20.06	peak
2	2390.000	2.65	39.41	42.06	54.00	-11.94	AVG

Note:1.Result (dBuV/m) = Correct Factor (dB/m) + Reading(dBuV).

2.Correction factor (dB/m) = Antenna Factor (dB/m) + Cable loss (dB) – Pre-Amplifier gain (dB).

3. When the peak results are less than average limit, so not need to evaluate the average.

Standard:	FCC Part 15.247	Test Distance:	3m
Test item:	Band edge	Power:	DC 3.7V
Frequency:	2402MHz	Temp.(°C)/Hum.(%RH):	26(°C)/60%RH
Mode:	Mode 4	Ant.Polar.:	Vertical

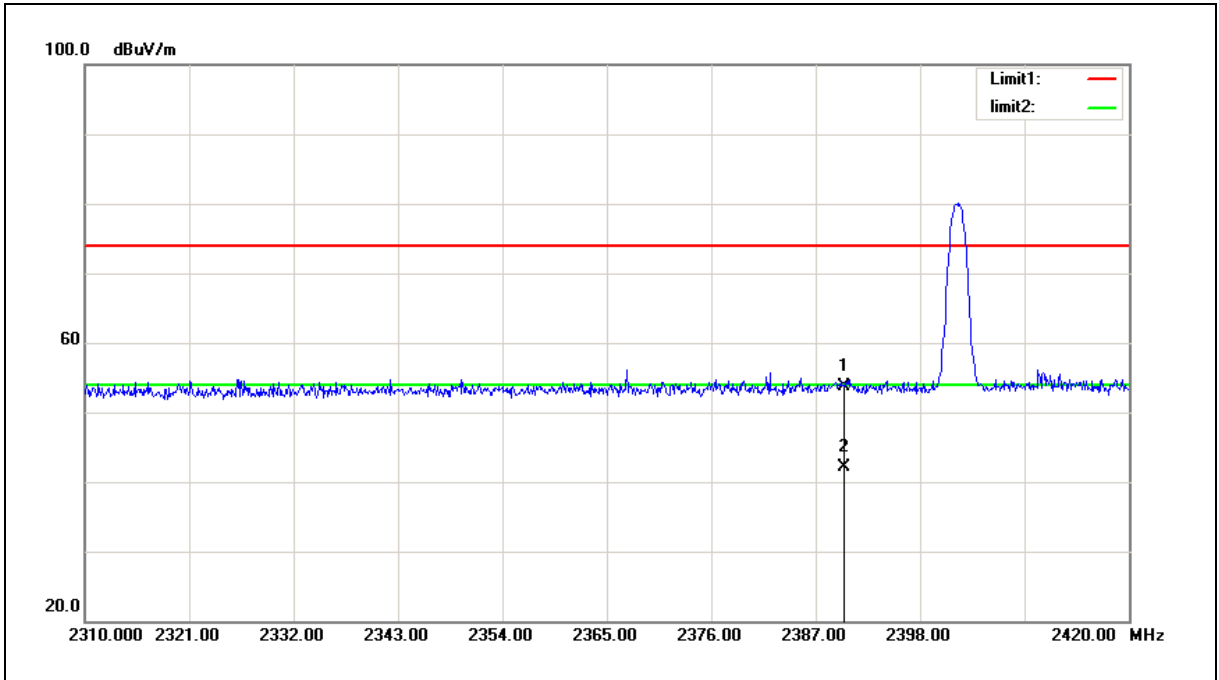

No.	Frequency (MHz)	Reading (dBuV)	Correct Factor (dB/m)	Result (dBuV/m)	Limit (dBuV/m)	Margin (dB)	Remark
1	2390.000	14.39	39.41	53.80	74.00	-20.20	peak
2	2390.000	2.64	39.41	42.05	54.00	-11.95	AVG

Note:1.Result (dBuV/m) = Correct Factor (dB/m) + Reading(dBuV).

2.Correction factor (dB/m) = Antenna Factor (dB/m) + Cable loss (dB) – Pre-Amplifier gain (dB).

3. When the peak results are less than average limit, so not need to evaluate the average.

Standard:	FCC Part 15.247	Test Distance:	3m
Test item:	Band edge	Power:	DC 3.7V
Frequency:	2480MHz	Temp.(°C)/Hum.(%RH):	26(°C)/60%RH
Mode:	Mode 4	Ant.Polar.:	Horizontal

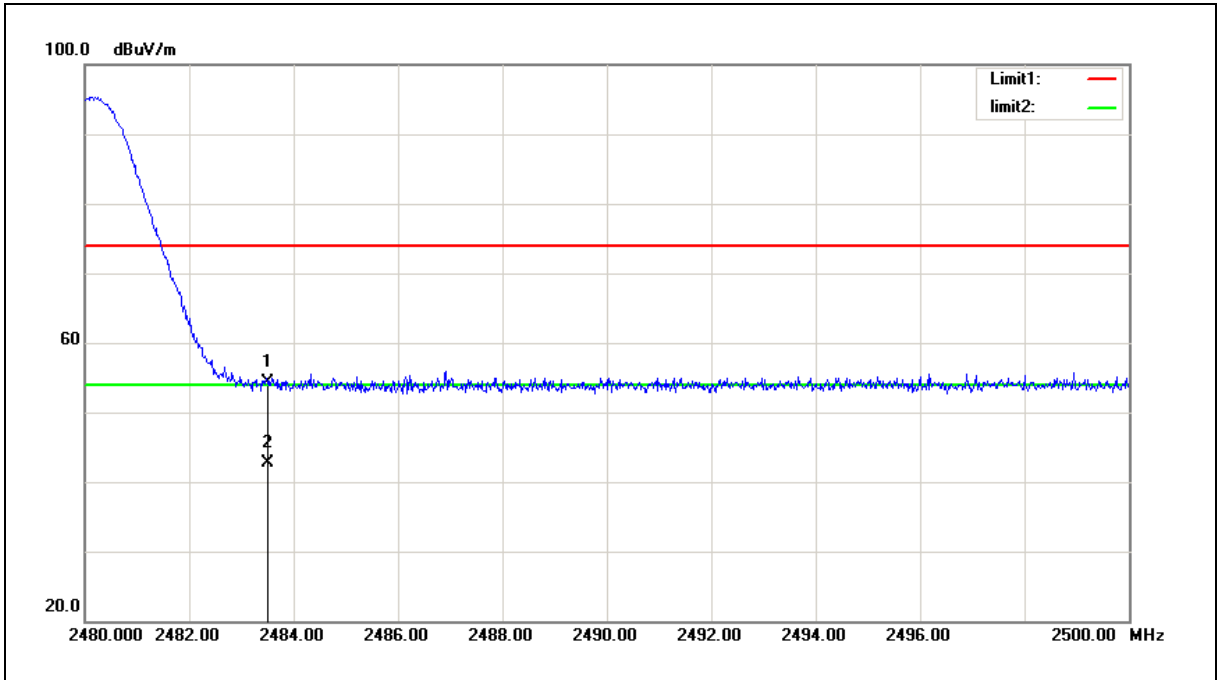

No.	Frequency (MHz)	Reading (dBuV)	Correct Factor (dB/m)	Result (dBuV/m)	Limit (dBuV/m)	Margin (dB)	Remark
1	2483.500	14.44	39.83	54.27	74.00	-19.73	peak
2	2483.500	2.79	39.83	42.62	54.00	-11.38	AVG

Note:1.Result (dBuV/m) = Correct Factor (dB/m) + Reading(dBuV).

2.Correction factor (dB/m) = Antenna Factor (dB/m) + Cable loss (dB) – Pre-Amplifier gain (dB).

3. When the peak results are less than average limit, so not need to evaluate the average.



Standard:	FCC Part 15.247	Test Distance:	3m
Test item:	Band edge	Power:	DC 3.7V
Frequency:	2480MHz	Temp.(°C)/Hum.(%RH):	26(°C)/60%RH
Mode:	Mode 4	Ant.Polar.:	Vertical

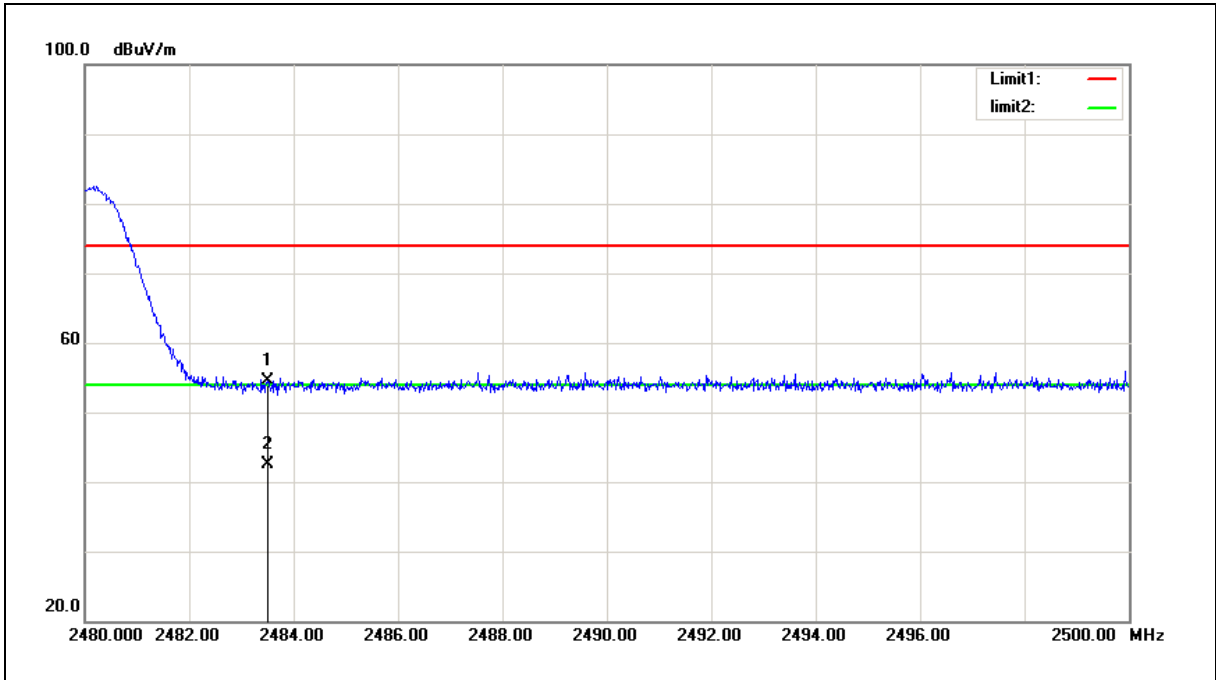

No.	Frequency (MHz)	Reading (dBuV)	Correct Factor (dB/m)	Result (dBuV/m)	Limit (dBuV/m)	Margin (dB)	Remark
1	2483.500	14.71	39.83	54.54	74.00	-19.46	peak
2	2483.500	2.77	39.83	42.60	54.00	-11.40	AVG

Note:1.Result (dBuV/m) = Correct Factor (dB/m) + Reading(dBuV).

2.Correction factor (dB/m) = Antenna Factor (dB/m) + Cable loss (dB) – Pre-Amplifier gain (dB).

3. When the peak results are less than average limit, so not need to evaluate the average.

Standard:	FCC Part 15.247	Test Distance:	3m
Test item:	Band edge	Power:	DC 3.7V
Frequency:	hopping	Temp.(°C)/Hum.(%RH):	26(°C)/60%RH
Mode:	Mode 4	Ant.Polar.:	Horizontal

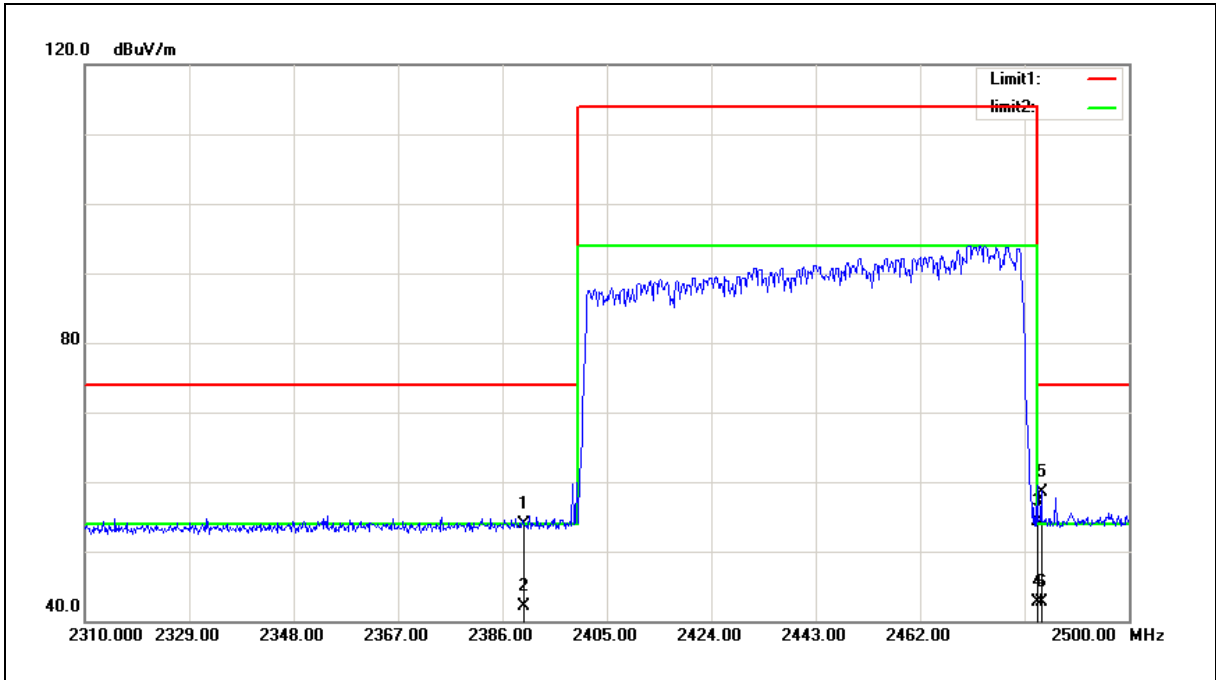

No.	Frequency (MHz)	Reading (dBuV)	Correct Factor (dB/m)	Result (dBuV/m)	Limit (dBuV/m)	Margin (dB)	Remark
1	2390.000	14.42	39.41	53.83	74.00	-20.17	peak
2	2390.000	2.64	39.41	42.05	54.00	-11.95	AVG
3	2483.500	14.39	39.83	54.22	74.00	-19.78	peak
4	2483.500	2.78	39.83	42.61	54.00	-11.39	AVG
5	2484.045	18.77	39.83	58.60	74.00	-15.40	peak
6	2484.045	2.78	39.83	42.61	54.00	-11.39	AVG

Note:1.Result (dBuV/m) = Correct Factor (dB/m) + Reading(dBuV).

2.Correction factor (dB/m) = Antenna Factor (dB/m) + Cable loss (dB) – Pre-Amplifier gain (dB).

3. When the peak results are less than average limit, so not need to evaluate the average.

Standard:	FCC Part 15.247	Test Distance:	3m
Test item:	Band edge	Power:	DC 3.7V
Frequency:	hopping	Temp.(°C)/Hum.(%RH):	26(°C)/60%RH
Mode:	Mode 4	Ant.Polar.:	Vertical

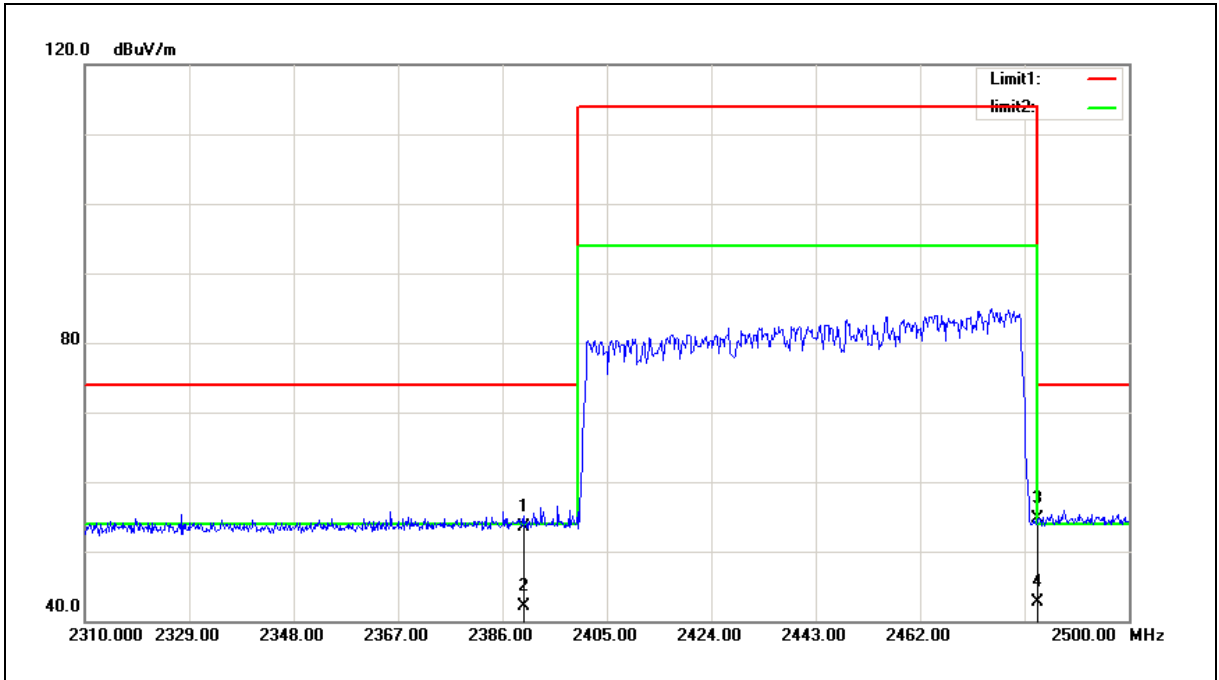

No.	Frequency (MHz)	Reading (dBuV)	Correct Factor (dB/m)	Result (dBuV/m)	Limit (dBuV/m)	Margin (dB)	Remark
1	2390.000	14.00	39.41	53.41	74.00	-20.59	peak
2	2390.000	2.64	39.41	42.05	54.00	-11.95	AVG
3	2483.500	14.91	39.83	54.74	74.00	-19.26	peak
4	2483.500	2.78	39.83	42.61	54.00	-11.39	AVG

Note:1.Result (dBuV/m) = Correct Factor (dB/m) + Reading(dBuV).

2.Correction factor (dB/m) = Antenna Factor (dB/m) + Cable loss (dB) – Pre-Amplifier gain (dB).

3. When the peak results are less than average limit, so not need to evaluate the average.