

TEST REPORT

Report No..... : KS2211S4711E01
FCC ID..... : 2AHYV-JKEYB
Applicant..... : PEAG, LLC dba JLab Audio
Address..... : 5927 Landau Ct. Carlsbad, CA 92008,USA
Manufacturer..... : GuangDong Simpreal Intelligent Technology Co., Ltd
Address..... : Room 2408, JiaHong ZhenXing DaSha, DongGuan Avenue #13,
DongCheng District, DongGuan City, GuangDong Province, P.R. China
Product Name..... : keyboard
Trademark..... : JLAB
Model/Type reference..... : JBuds Keyboard
Standard..... : 47 CFR Part 15.247
Date of Receipt..... : November 7, 2022
Date of Test Date..... : November 7, 2022 to November 11, 2022
Date of issue..... : November 11, 2022
Test result..... : Pass

Prepared by: Pai Zheng
(Printed name + Signature)



Approved by: Sky Dong
(Printed name + Signature)



Testing Laboratory Name...: KSIGN(Guangdong) Testing Co., Ltd.

Address..... : West Side of 1/F., Building C, Zone A, Fuyuan New Factory, Jiujiu Industrial Park, Minzhu, Shatou, Shajing, Bao'an District, Shenzhen, Guangdong, China

This test report may be duplicated completely for legal use with the approval of the applicant. It should not be reproduced except in full, without the written approval of our laboratory. The client should not use it to claim product endorsement by KSIGN. The test results in the report only apply to the tested sample. The test report shall be invalid without all the signatures of testing engineers, reviewer and approver. Any objections must be raised to TSTLMS within 15 days since the date when the report is received. It will not be taken into consideration beyond this limit. The test report merely corresponds to the test sample. The report is invalid if it is not stamped with the "Testing Special Stamp" and the "Riding Seam Stamp".

TRF EMC_R1

Add: West Side of 1/F., Building C, Zone A, Fuyuan New Factory, Jiujiu Industrial Park, Minzhu, Shatou, Shajing, Bao'an District, Shenzhen, Guangdong, China

Tel: +(86) 0755-2985 2678 Fax: +(86) 0755-2985 2397 E-mail: info@gdksign.cn Web: www.gdksign.com

TABLE OF CONTENTS

Page

1. TEST SUMMARY	4
1.1. Test Standards	4
1.2. Report Version	4
1.3. Test Description	5
1.4. Test Facility	6
1.5. Measurement Uncertainty	7
2. GENERAL INFORMATION	8
2.1. General Description Of EUT	8
2.2. Accessory Equipment Information	8
2.3. Description of Test Modes	8
2.4. Measurement Instruments List	9
3. EVALUATION RESULTS (EVALUATION)	13
3.1. Antenna requirement	13
3.1.1. Conclusion:	13
4. RADIO SPECTRUM MATTER TEST RESULTS (RF)	13
4.1. Conducted Emission at AC power line	13
4.1.1. E.U.T. Operation:	13
4.1.2. Test Setup Diagram:	14
4.1.3. Test Data:	15
4.2. Occupied Bandwidth	17
4.2.1. E.U.T. Operation:	17
4.2.2. Test Setup Diagram:	17
4.2.3. Test Data:	17
4.3. Maximum Conducted Output Power	18
4.3.1. E.U.T. Operation:	18
4.3.2. Test Setup Diagram:	19
4.3.3. Test Data:	19
4.4. Power Spectral Density	20
4.4.1. E.U.T. Operation:	20
4.4.2. Test Setup Diagram:	20
4.4.3. Test Data:	20
4.5. Emissions in non-restricted frequency bands	21
4.5.1. E.U.T. Operation:	21
4.5.2. Test Setup Diagram:	22
4.5.3. Test Data:	22
4.6. Emissions around the fundamental	23
4.6.1. E.U.T. Operation:	23
4.6.2. Test Data:	24
4.7. Emissions in restricted frequency bands (below 1GHz)	28
4.7.1. E.U.T. Operation:	28
4.7.2. Test Data:	29
4.8. Emissions in restricted frequency bands (above 1GHz)	31
4.8.1. E.U.T. Operation:	31
4.8.2. Test Data:	32
5. EUT TEST PHOTOS	38
6. PHOTOGRAPHS OF EUT CONSTRUCTIONAL	40
6.1. Appendix A: DTS Bandwidth	42

6.1.1. Test Result	42
6.1.2. Test Graphs	43
6.2. Appendix B: Occupied Channel Bandwidth	44
6.2.1. Test Result	44
6.2.2. Test Graphs	45
6.3. Appendix C: Maximum conducted output power	46
6.3.1. Test Result Peak	46
6.3.2. Test Graphs Peak	47
6.4. Appendix D: Maximum power spectral density	48
6.4.1. Test Result	48
6.4.2. Test Graphs	49
6.5. Appendix F: Band edge measurements	50
6.5.1.	50
6.5.2. Test Result	50
6.5.3. Test Graphs	51
6.6. Appendix G: Conducted Spurious Emission	52
6.6.1. Test Result	52
6.6.2. Test Graphs	53
6.7. Appendix H: Duty Cycle	55
6.7.1. Test Result	55
6.7.2. Test Graphs	56

1. TEST SUMMARY

1.1. Test Standards

The tests were performed according to following standards:

47 CFR Part 15.247: Operation within the bands 902-928 MHz, 2400-2483.5 MHz, and 5725-5850 MHz

1.2. Report Version

Revised No.	Date of issue	Description
01	November 11, 2022	Original

1.3. Test Description

Test Item	Standard	Requirement	Result
Antenna requirement	47 CFR Part 15.247	Part 15.203	Pass
Conducted Emission at AC power line	47 CFR Part 15.247	47 CFR 15.207(a)	Pass
Occupied Bandwidth	47 CFR Part 15.247	47 CFR 15.247(a)(2)	Pass
Maximum Conducted Output Power	47 CFR Part 15.247	47 CFR 15.247(b)(3)	Pass
Power Spectral Density	47 CFR Part 15.247	47 CFR 15.247(e)	Pass
Emissions in non-restricted frequency bands	47 CFR Part 15.247	47 CFR 15.247(d)	Pass
Emissions around the fundamental	47 CFR Part 15.247	47 CFR 15.247(d)	Pass
Emissions in restricted frequency bands (below 1GHz)	47 CFR Part 15.247	47 CFR 15.247(d)	Pass
Emissions in restricted frequency bands (above 1GHz)	47 CFR Part 15.247	47 CFR 15.247(d)	Pass

1.4. Test Facility

KSIGN(Guangdong) Testing Co., Ltd.

West Side of 1/F., Building C, Zone A, Fuyuan New Factory, Jiujiu Industrial Park, Minzhu, Shatou, Shajing, Bao'an District, Shenzhen, Guangdong, China

The test facility is recognized, certified, or accredited by the following organizations:

CNAS-Lab Code: L13261

KSIGN(Guangdong) Testing Co., Ltd. has been assessed and proved to be in Compliance with CNAS-CL01 Accreditation Criteria for Testing and Calibration Laboratories (identical to ISO/IEC17025: 2017 General Requirements) for the Competence of Testing and Calibration Laboratories.

A2LA-Lab Cert. No.: 5457.01

KSIGN(Guangdong) Testing Co., Ltd. EMC Laboratory has been accredited by A2LA for technical competence in the field of electrical testing, and proved to be in compliance with ISO/IEC 17025:2017 General Requirements for the Competence of Testing and Calibration Laboratories and any additional program requirements in the identified field of testing

ISED#: 25693 CAB identifier.: CN0096

KSIGN(Guangdong) Testing Co., Ltd. has been listed by Innovation, Science and Economic Development Canada to perform electromagnetic emission measurement.

FCC-Registration No.: 294912 Designation Number: CN1328

KSIGN(Guangdong) Testing Co., Ltd. EMC Laboratory has been listed on the US Federal Communications Commission list of test facilities recognized to perform electromagnetic emissions measurements.

1.5. Measurement Uncertainty

Test Items	Measurement Uncertainty
Conducted Emission (150k-30MHz)	± 3.34dB
Output Power, Conducted	± 1.4dB
PSD, Conducted	± 1.0dB
Spurious Emissions, Conducted	± 3.3dB
RSE (1-18GHz)	± 4.68dB
RSE (30-1000MHz)	± 5.7dB
RSE (18-40GHz)	± 5.18dB

The reported uncertainty of measurement $y \pm U$, where expanded uncertainty U is based on a standard uncertainty multiplied by a coverage factor of $k=2$, providing a level of confidence of approximately 95 %.

2. GENERAL INFORMATION

2.1. General Description Of EUT

Product Name:	keyboard
Trademark:	JLAB
Model / Type reference:	JBuds Keyboard
Power Supply:	DC 3.7V from battery
Operation Frequency:	2402MHz to 2480MHz
Number of Channels:	40
Modulation Type:	GFSK
Antenna Type:	PCB
Antenna Gain:	-0.71dBi

2.2. Accessory Equipment Information

The EUT was tested as an independent device.

2.3. Description of Test Modes

No.	Title	Description of Mode
Test Mode1	TX mode	Keep the EUT connect to AC power line and works in continuously transmitting mode with GFSK modulation.

2.4. Measurement Instruments List

Conducted Emission at AC power line				
Test Equipment	Manufacturer	Model No.	Serial No.	Cal. Until
LISN	R&S	ENV432	1326.6105.02	2023-03-04
EMI Test Receiver	R&S	ESR	102524	2023-03-04
Manual RF Switch	JS TOYO	/	MSW-01/002	2023-03-04
ISN CAT6	Schwarzbeck	CAT5 8158	227	2023-03-04
Color Signal Generator	Philips	PM5418	672926	2023-03-04
Power Absorbing Clamp	R&S	MDS-21	100925	2023-03-26

Occupied Bandwidth				
Test Equipment	Manufacturer	Model No.	Serial No.	Cal. Until
Wideband Radio Communication Tester	R&S	CMU200	115297	2023-03-04
Audio Analyzer	R&S	UPL16	100001	2023-03-04
Shielding box	Gxiong	GX-5915A	2201113	2023-04-23
High Pass Filter	COM-MW Technology Co., Ltd	ZHPF-M1.2-9G-187	09203403	2023-03-04
Band Stop Filter	COM-MW Technology Co., Ltd	ZBSF6-C820-920-188	09203401	2023-03-04
Splitter	COM-MW Technology Co., Ltd	ZPD-M1-8-2103	09203407	2023-03-04
Coaxial Cable	BEBES	A40-2.92M2.92 F-4.5M	1907021	2023-03-04
Hygrothermograph	Anymetre	JB913	/	2023-03-07
Climate Chamber	Angul	AGNH80L	1903042120	2023-03-04
Spectrum Analyzer	HP	8593E	3831U02087	2023-03-04
Dual Output DC Power Supply	Agilent	E3646A	MY40009992	2023-03-04
RF Control Unit	Tonscend	JS0806-2	/	2023-03-04
Analog Signal Generator	HP	83752A	3344A00337	2023-03-04
Vector Signal Generator	Agilent	N5182A	MY50142520	2023-03-04
Wideband Radio Communication Tester	R&S	CMW500	157282	2023-03-04
Spectrum Analyzer	R&S	FSV40-N	101798	2023-03-04

Maximum Conducted Output Power				
Test Equipment	Manufacturer	Model No.	Serial No.	Cal. Until
Wideband Radio Communication Tester	R&S	CMU200	115297	2023-03-04
Audio Analyzer	R&S	UPL16	100001	2023-03-04
Shielding box	Gxiong	GX-5915A	2201113	2023-04-23
High Pass Filter	COM-MW	ZHPF-M1.2-9G-	09203403	2023-03-04

TRF EMC_R1

Add: West Side of 1/F., Building C, Zone A, Fuyuan New Factory, Jiujiu Industrial Park, Minzhu, Shatou, Shajing, Bao'an District, Shenzhen, Guangdong, China

Tel: +(86) 0755-2985 2678 Fax: +(86) 0755-2985 2397 E-mail: info@gdkesign.cn Web: www.gdkesign.com

	Technology Co., Ltd	187		
Band Stop Filter	COM-MW Technology Co., Ltd	ZBSF6-C820-920-188	09203401	2023-03-04
Splitter	COM-MW Technology Co., Ltd	ZPD-M1-8-2103	09203407	2023-03-04
Coaxial Cable	BEBES	A40-2.92M2.92 F-4.5M	1907021	2023-03-04
Hygrothermograph	Anymetre	JB913	/	2023-03-07
Climate Chamber	Angul	AGNH80L	1903042120	2023-03-04
Spectrum Analyzer	HP	8593E	3831U02087	2023-03-04
Dual Output DC Power Supply	Agilent	E3646A	MY40009992	2023-03-04
RF Control Unit	Tonscend	JS0806-2	/	2023-03-04
Analog Signal Generator	HP	83752A	3344A00337	2023-03-04
Vector Signal Generator	Agilent	N5182A	MY50142520	2023-03-04
Wideband Radio Communication Tester	R&S	CMW500	157282	2023-03-04
Spectrum Analyzer	R&S	FSV40-N	101798	2023-03-04

Power Spectral Density				
Test Equipment	Manufacturer	Model No.	Serial No.	Cal. Until
Wideband Radio Communication Tester	R&S	CMU200	115297	2023-03-04
Audio Analyzer	R&S	UPL16	100001	2023-03-04
Shielding box	Gxiong	GX-5915A	2201113	2023-04-23
High Pass Filter	COM-MW Technology Co., Ltd	ZHPF-M1.2-9G-187	09203403	2023-03-04
Band Stop Filter	COM-MW Technology Co., Ltd	ZBSF6-C820-920-188	09203401	2023-03-04
Splitter	COM-MW Technology Co., Ltd	ZPD-M1-8-2103	09203407	2023-03-04
Coaxial Cable	BEBES	A40-2.92M2.92 F-4.5M	1907021	2023-03-04
Hygrothermograph	Anymetre	JB913	/	2023-03-07
Climate Chamber	Angul	AGNH80L	1903042120	2023-03-04
Spectrum Analyzer	HP	8593E	3831U02087	2023-03-04
Dual Output DC Power Supply	Agilent	E3646A	MY40009992	2023-03-04
RF Control Unit	Tonscend	JS0806-2	/	2023-03-04
Analog Signal Generator	HP	83752A	3344A00337	2023-03-04
Vector Signal Generator	Agilent	N5182A	MY50142520	2023-03-04
Wideband Radio	R&S	CMW500	157282	2023-03-04

TRF EMC_R1

Add: West Side of 1/F., Building C, Zone A, Fuyuan New Factory, Jiujiu Industrial Park, Minzhu, Shatou, Shajing, Bao'an District, Shenzhen, Guangdong, China

Tel: +(86) 0755-2985 2678 Fax: +(86) 0755-2985 2397 E-mail: info@gdkesign.cn Web: www.gdkesign.com

Communication Tester				
Spectrum Analyzer	R&S	FSV40-N	101798	2023-03-04

Emissions in non-restricted frequency bands				
Test Equipment	Manufacturer	Model No.	Serial No.	Cal. Until
Wideband Radio Communication Tester	R&S	CMU200	115297	2023-03-04
Audio Analyzer	R&S	UPL16	100001	2023-03-04
Shielding box	Gxiong	GX-5915A	2201113	2023-04-23
High Pass Filter	COM-MW Technology Co., Ltd	ZHPF-M1.2-9G-187	09203403	2023-03-04
Band Stop Filter	COM-MW Technology Co., Ltd	ZBSF6-C820-920-188	09203401	2023-03-04
Splitter	COM-MW Technology Co., Ltd	ZPD-M1-8-2103	09203407	2023-03-04
Coaxial Cable	BEBES	A40-2.92M2.92 F-4.5M	1907021	2023-03-04
Hygrothermograph	Anymetre	JB913	/	2023-03-07
Climate Chamber	Angul	AGNH80L	1903042120	2023-03-04
Spectrum Analyzer	HP	8593E	3831U02087	2023-03-04
Dual Output DC Power Supply	Agilent	E3646A	MY40009992	2023-03-04
RF Control Unit	Tonscend	JS0806-2	/	2023-03-04
Analog Signal Generator	HP	83752A	3344A00337	2023-03-04
Vector Signal Generator	Agilent	N5182A	MY50142520	2023-03-04
Wideband Radio Communication Tester	R&S	CMW500	157282	2023-03-04
Spectrum Analyzer	R&S	FSV40-N	101798	2023-03-04

Emissions around the fundamental				
Test Equipment	Manufacturer	Model No.	Serial No.	Cal. Until
Ultra-Broadband logarithmic period Antenna	Schwarzbeck	VULB 9163	1230	2023-04-12
Pre-Amplifier	Schwarzbeck	BBV 9745	9745#129	2023-03-04
Color Signal Generator	Philips	PM5418	672926	2023-03-04
Broadcast Television Signal Generator	R&S	SFE100	141038	2023-03-04
Analog Signal Generator	Agilent	8648A	3847M00445	2023-03-04
EMI Test Receiver	R&S	ESR	102525	2023-03-04
Horn Antenna	Schwarzbeck	BBHA 9120 D	2023	2023-03-29
Pre-Amplifier	EMCI	EMC051835SE	980662	2023-03-04
Spectrum Analyzer	Keysight	N9020A	MY46471971	2023-03-04
Loop Antenna	Beijin ZHINAN	ZN30900C	18050	2023-03-05

TRF EMC_R1

Add: West Side of 1/F., Building C, Zone A, Fuyuan New Factory, Jiujiu Industrial Park, Minzhu, Shatou, Shajing, Bao'an District, Shenzhen, Guangdong, China

Tel: +(86) 0755-2985 2678 Fax: +(86) 0755-2985 2397 E-mail: info@gdkesign.cn Web: www.gdkesign.com

Emissions in restricted frequency bands (below 1GHz)				
Test Equipment	Manufacturer	Model No.	Serial No.	Cal. Until
Ultra-Broadband logarithmic period Antenna	Schwarzbeck	VULB 9163	1230	2023-04-12
Pre-Amplifier	Schwarzbeck	BBV 9745	9745#129	2023-03-04
Color Signal Generator	Philips	PM5418	672926	2023-03-04
Broadcast Television Signal Generator	R&S	SFE100	141038	2023-03-04
Analog Signal Generator	Agilent	8648A	3847M00445	2023-03-04
EMI Test Receiver	R&S	ESR	102525	2023-03-04
Horn Antenna	Schwarzbeck	BBHA 9120 D	2023	2023-03-29
Pre-Amplifier	EMCI	EMC051835SE	980662	2023-03-04
Spectrum Analyzer	Keysight	N9020A	MY46471971	2023-03-04
Loop Antenna	Beijin ZHINAN	ZN30900C	18050	2023-03-05

Emissions in restricted frequency bands (above 1GHz)				
Test Equipment	Manufacturer	Model No.	Serial No.	Cal. Until
Ultra-Broadband logarithmic period Antenna	Schwarzbeck	VULB 9163	1230	2023-04-12
Pre-Amplifier	Schwarzbeck	BBV 9745	9745#129	2023-03-04
Color Signal Generator	Philips	PM5418	672926	2023-03-04
Broadcast Television Signal Generator	R&S	SFE100	141038	2023-03-04
Analog Signal Generator	Agilent	8648A	3847M00445	2023-03-04
EMI Test Receiver	R&S	ESR	102525	2023-03-04
Horn Antenna	Schwarzbeck	BBHA 9120 D	2023	2023-03-29
Pre-Amplifier	EMCI	EMC051835SE	980662	2023-03-04
Spectrum Analyzer	Keysight	N9020A	MY46471971	2023-03-04
Loop Antenna	Beijin ZHINAN	ZN30900C	18050	2023-03-05

3. Evaluation Results (Evaluation)

3.1. Antenna requirement

Test Requirement:	An intentional radiator shall be designed to ensure that no antenna other than that furnished by the responsible party shall be used with the device. The use of a permanently attached antenna or of an antenna that uses a unique coupling to the intentional radiator shall be considered sufficient to comply with the provisions of this section.
-------------------	--

3.1.1. Conclusion:

The directional gain of the antenna less than 6dBi. It comply with the standard requirement. In case of replacement of broken antenna the same antenna type must be used.
Antenna structure please refer to the EUT internal photographs antenna photo.

4. Radio Spectrum Matter Test Results (RF)

4.1. Conducted Emission at AC power line

Test Requirement:	Except as shown in paragraphs (b)and (c)of this section, for an intentional radiator that is designed to be connected to the public utility (AC) power line, the radio frequency voltage that is conducted back onto the AC power line on any frequency or frequencies, within the band 150 kHz to 30 MHz, shall not exceed the limits in the following table, as measured using a 50 μH/50 ohms line impedance stabilization network (LISN).		
Test Limit:	Frequency of emission (MHz)	Conducted limit (dBμV)	
		Quasi-peak	Average
	0.15-0.5	66 to 56*	56 to 46*
	0.5-5	56	46
	5-30	60	50
	*Decreases with the logarithm of the frequency.		
Test Method:	Refer to ANSI C63.10-2013 section 6.2, standard test method for ac power-line conducted emissions from unlicensed wireless devices		

4.1.1. E.U.T. Operation:

Operating Environment:	
Temperature:	25.1 °C
Humidity:	46.8 %
Atmospheric Pressure:	102 kPa
Final test mode:	Test Mode1

4.1.2. Test Setup Diagram:

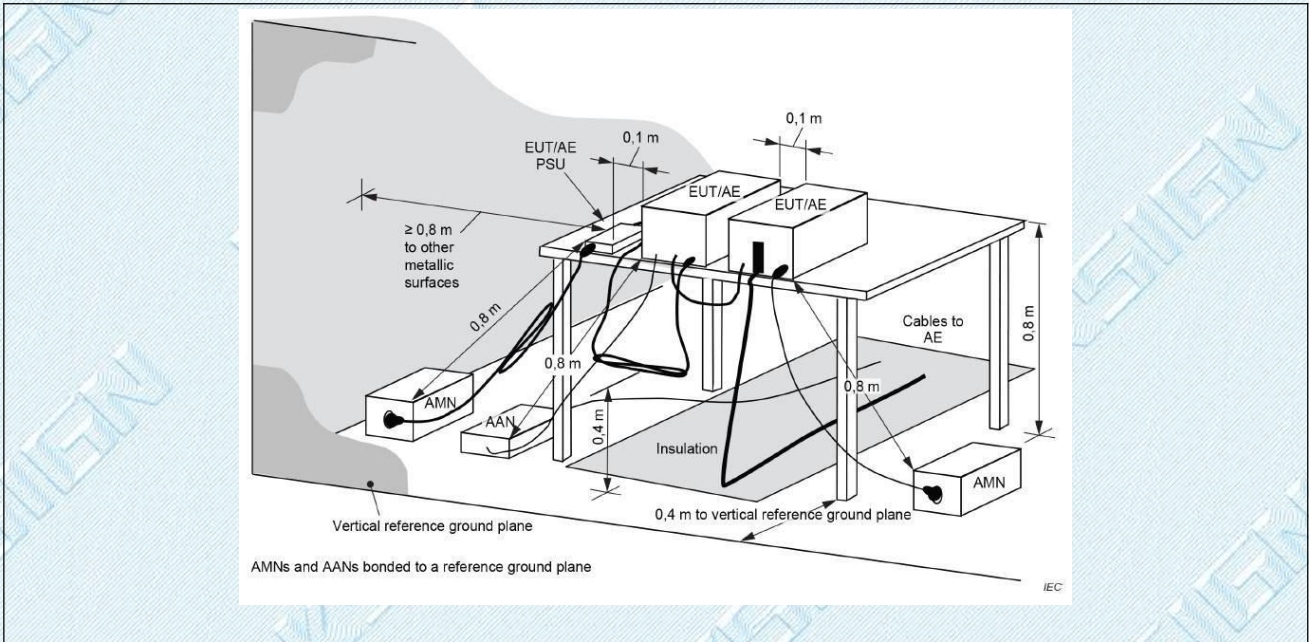

4.1.3. Test Data:

Test Mode1 / Line: Line / Band: 2.4G / BW: 1

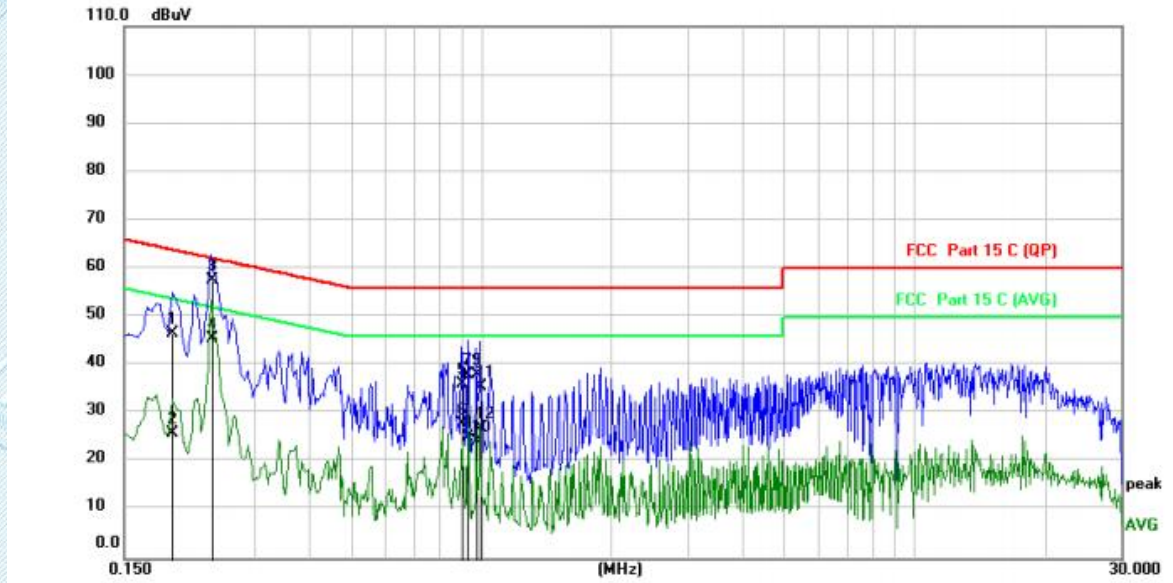

No. Mk.	Freq. MHz	Reading Level dBuV	Correct Factor dB	Measure- ment dBuV	Limit dBuV	Over dB	Detector	Comment
1	0.1940	35.76	10.75	46.51	63.86	-17.35	QP	
2	0.1940	15.26	10.75	26.01	53.86	-27.85	AVG	
3 *	0.2380	46.87	10.74	57.61	62.17	-4.56	QP	
4	0.2380	34.79	10.74	45.53	52.17	-6.64	AVG	
5	0.9020	25.73	10.48	36.21	56.00	-19.79	QP	
6	0.9020	17.43	10.48	27.91	46.00	-18.09	AVG	
7	0.9300	27.52	10.49	38.01	56.00	-17.99	QP	
8	0.9300	14.81	10.49	25.30	46.00	-20.70	AVG	
9	0.9740	27.54	10.50	38.04	56.00	-17.96	QP	
10	0.9740	13.89	10.50	24.39	46.00	-21.61	AVG	
11	0.9980	25.03	10.51	35.54	56.00	-20.46	QP	
12	0.9980	16.60	10.51	27.11	46.00	-18.89	AVG	

Test Mode1 / Line: Neutral / Band: 2.4G / BW: 1

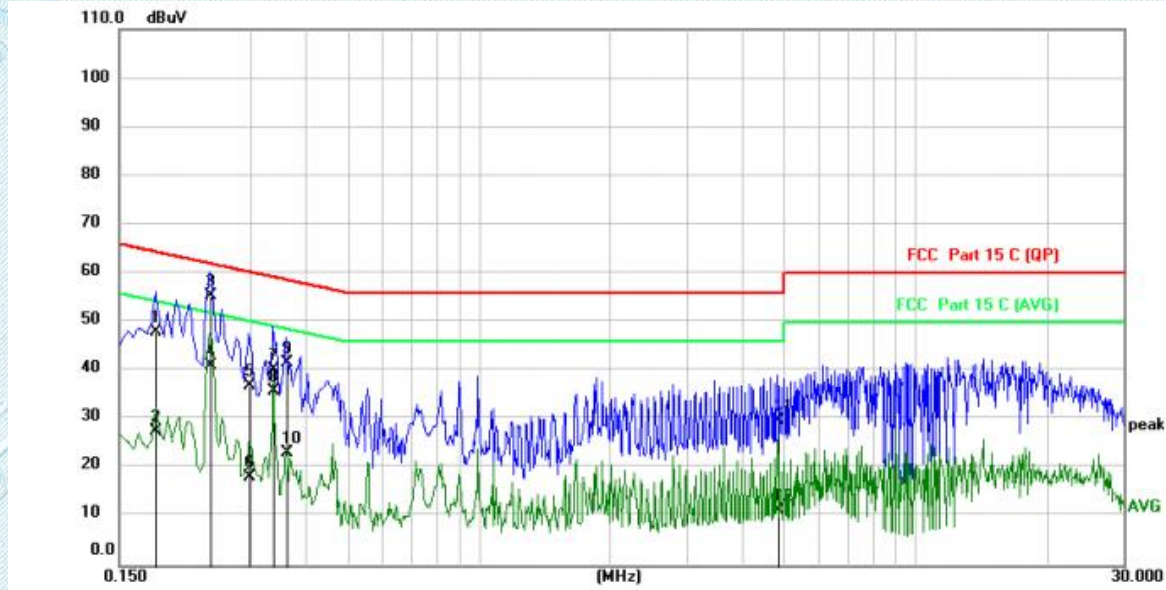

No. Mk.	Freq. MHz	Reading Level dBuV	Correct Factor dB	Measurement dBuV	Limit dBuV	Over dB	Detector	Comment
1	0.1819	37.29	10.74	48.03	64.40	-16.37	QP	
2	0.1819	16.79	10.74	27.53	54.40	-26.87	AVG	
3 *	0.2420	44.67	10.72	55.39	62.03	-6.64	QP	
4	0.2420	30.53	10.72	41.25	52.03	-10.78	AVG	
5	0.2980	26.40	10.51	36.91	60.30	-23.39	QP	
6	0.2980	7.87	10.51	18.38	50.30	-31.92	AVG	
7	0.3379	29.68	10.53	40.21	59.25	-19.04	QP	
8	0.3379	25.37	10.53	35.90	49.25	-13.35	AVG	
9	0.3620	31.06	10.53	41.59	58.68	-17.09	QP	
10	0.3620	12.81	10.53	23.34	48.68	-25.34	AVG	
11	4.8460	19.10	10.62	29.72	56.00	-26.28	QP	
12	4.8460	0.79	10.62	11.41	46.00	-34.59	AVG	

TRF EMC_R1

Add: West Side of 1/F., Building C, Zone A, Fuyuan New Factory, Jiujiu Industrial Park, Minzhu, Shatou, Shajing, Bao'an District, Shenzhen, Guangdong, China

Tel: +(86) 0755-2985 2678 Fax: +(86) 0755-2985 2397 E-mail: info@gdkesign.cn Web: www.gdkesign.com

4.2. Occupied Bandwidth

Test Requirement:	Systems using digital modulation techniques may operate in the 902-928 MHz, and 2400-2483.5 MHz bands. The minimum 6 dB bandwidth shall be at least 500 kHz.
Test Limit:	Section (a)(2), Systems using digital modulation techniques may operate in the 902-928 MHz, and 2400-2483.5 MHz bands. The minimum 6 dB bandwidth shall be at least 500 kHz.
Test Method:	DTS bandwidth
Procedure:	<ul style="list-style-type: none"> a) Set RBW = 100 kHz. b) Set the VBW \geq [3 × RBW]. c) Detector = peak. d) Trace mode = max hold. e) Sweep = auto couple. f) Allow the trace to stabilize. g) Measure the maximum width of the emission that is constrained by the frequencies associated with the two outermost amplitude points (upper and lower frequencies) that are attenuated by 6 dB relative to the maximum level measured in the fundamental emission.

4.2.1. E.U.T. Operation:

Operating Environment:	
Temperature:	26 °C
Humidity:	46.1 %
Atmospheric Pressure:	101 kPa
Final test mode:	Test Mode 1

4.2.2. Test Setup Diagram:

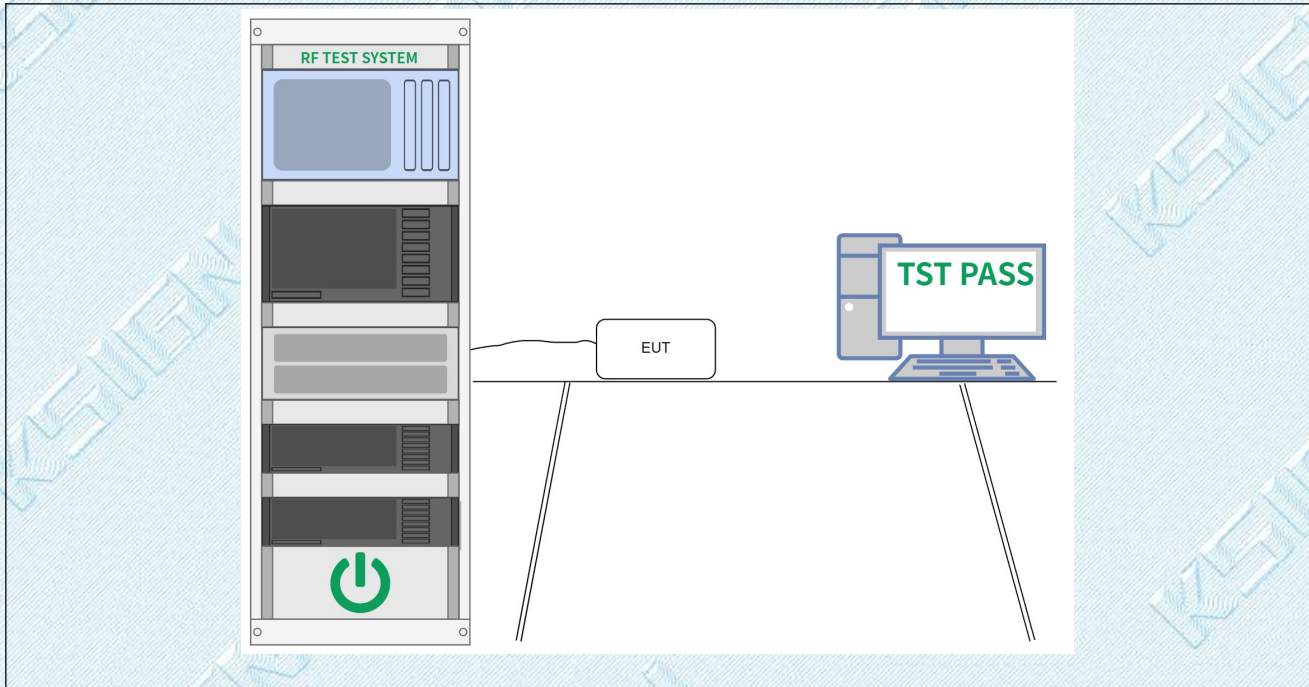

4.2.3. Test Data:

Please Refer to Appendix for Details.

4.3. Maximum Conducted Output Power

Test Requirement:	For systems using digital modulation in the 902-928 MHz, 2400-2483.5 MHz, and 5725-5850 MHz bands: 1 Watt. As an alternative to a peak power measurement, compliance with the one Watt limit can be based on a measurement of the maximum conducted output power. Maximum Conducted Output Power is defined as the total transmit power delivered to all antennas and antenna elements averaged across all symbols in the signaling alphabet when the transmitter is operating at its maximum power control level. Power must be summed across all antennas and antenna elements. The average must not include any time intervals during which the transmitter is off or is transmitting at a reduced power level. If multiple modes of operation are possible (e.g., alternative modulation methods), the maximum conducted output power is the highest total transmit power occurring in any mode.
Test Limit:	For systems using digital modulation in the 902-928 MHz, 2400-2483.5 MHz, and 5725-5850 MHz bands: 1 Watt. As an alternative to a peak power measurement, compliance with the one Watt limit can be based on a measurement of the maximum conducted output power. Maximum Conducted Output Power is defined as the total transmit power delivered to all antennas and antenna elements averaged across all symbols in the signaling alphabet when the transmitter is operating at its maximum power control level. Power must be summed across all antennas and antenna elements. The average must not include any time intervals during which the transmitter is off or is transmitting at a reduced power level. If multiple modes of operation are possible (e.g., alternative modulation methods), the maximum conducted output power is the highest total transmit power occurring in any mode.
Test Method:	Maximum peak conducted output power
Procedure:	ANSI C63.10-2013, section 11.9.1 Maximum peak conducted output power

4.3.1. E.U.T. Operation:

Operating Environment:	
Temperature:	26 °C
Humidity:	46.1 %
Atmospheric Pressure:	101 kPa
Final test mode:	Test Mode 1

4.3.2. Test Setup Diagram:

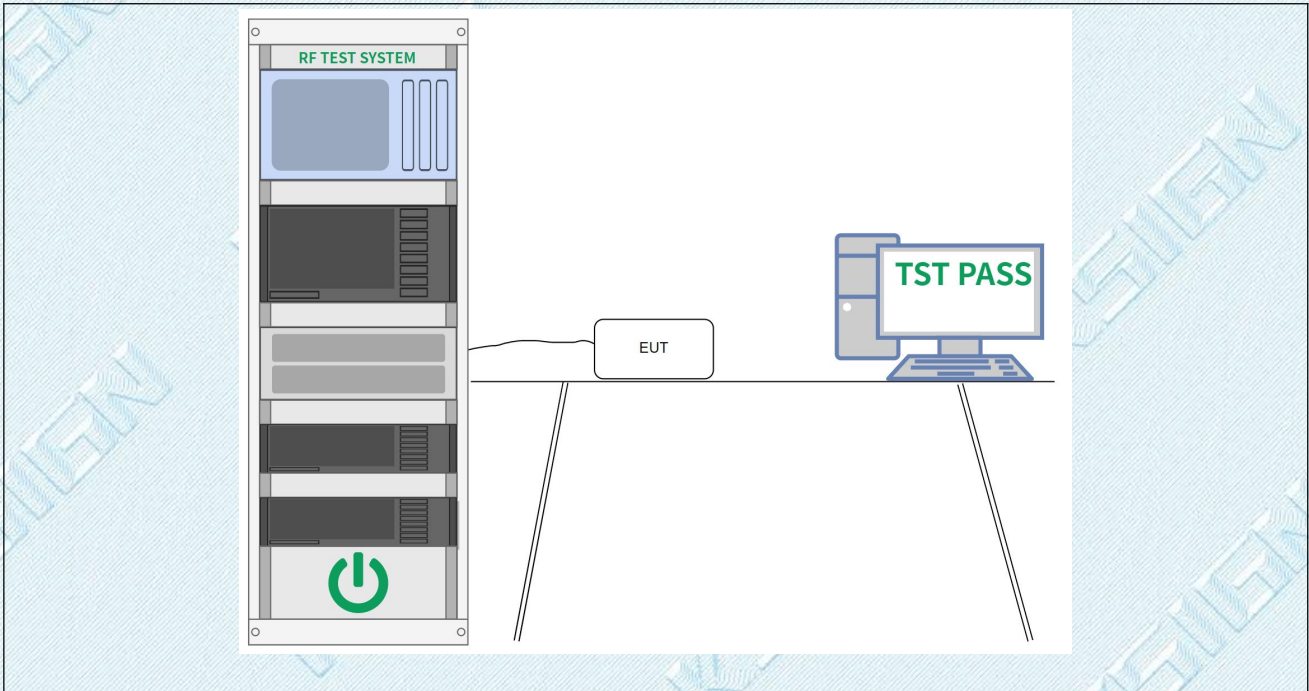

4.3.3. Test Data:

Please Refer to Appendix for Details.

4.4. Power Spectral Density

Test Requirement:	For digitally modulated systems, the power spectral density conducted from the intentional radiator to the antenna shall not be greater than 8 dBm in any 3 kHz band during any time interval of continuous transmission. This power spectral density shall be determined in accordance with the provisions of paragraph (b) of this section. The same method of determining the conducted output power shall be used to determine the power spectral density.
Test Limit:	For digitally modulated systems, the power spectral density conducted from the intentional radiator to the antenna shall not be greater than 8 dBm in any 3 kHz band during any time interval of continuous transmission. This power spectral density shall be determined in accordance with the provisions of paragraph (b) of this section. The same method of determining the conducted output power shall be used to determine the power spectral density.
Test Method:	Maximum power spectral density level in the fundamental emission

4.4.1. E.U.T. Operation:

Operating Environment:	
Temperature:	26 °C
Humidity:	46.1 %
Atmospheric Pressure:	101 kPa
Final test mode:	Test Mode1

4.4.2. Test Setup Diagram:

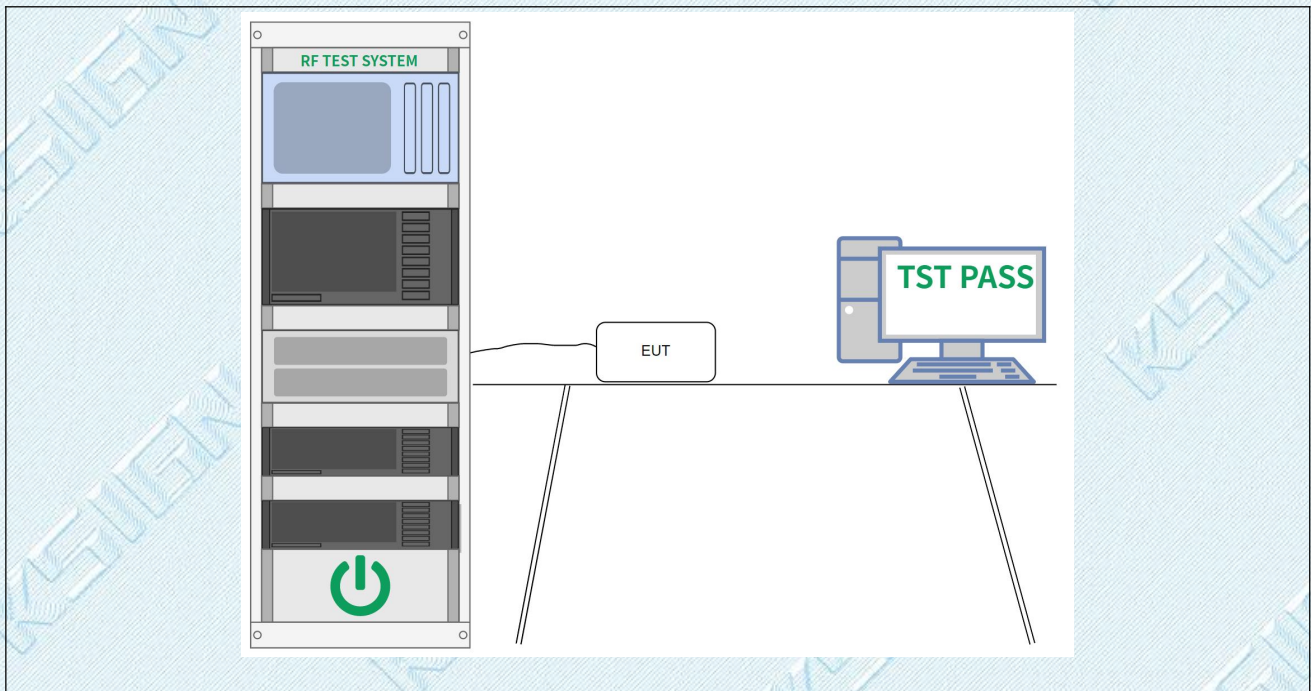

4.4.3. Test Data:

Please Refer to Appendix for Details.

4.5. Emissions in non-restricted frequency bands

Test Requirement:	In any 100 kHz bandwidth outside the frequency band in which the spread spectrum or digitally modulated intentional radiator is operating, the radio frequency power that is produced by the intentional radiator shall be at least 20 dB below that in the 100 kHz bandwidth within the band that contains the highest level of the desired power, based on either an RF conducted or a radiated measurement, provided the transmitter demonstrates compliance with the peak conducted power limits. If the transmitter complies with the conducted power limits based on the use of RMS averaging over a time interval, as permitted under paragraph (b)(3) of this section, the attenuation required under this paragraph shall be 30 dB instead of 20 dB. Attenuation below the general limits specified in § 15.209(a) is not required.
Test Limit:	In any 100 kHz bandwidth outside the frequency band in which the spread spectrum or digitally modulated intentional radiator is operating, the radio frequency power that is produced by the intentional radiator shall be at least 20 dB below that in the 100 kHz bandwidth within the band that contains the highest level of the desired power, based on either an RF conducted or a radiated measurement, provided the transmitter demonstrates compliance with the peak conducted power limits. If the transmitter complies with the conducted power limits based on the use of RMS averaging over a time interval, as permitted under paragraph (b)(3) of this section, the attenuation required under this paragraph shall be 30 dB instead of 20 dB. Attenuation below the general limits specified in § 15.209(a) is not required.
Test Method:	Emissions in nonrestricted frequency bands
Procedure:	ANSI C63.10-2013 Section 11.11.1, Section 11.11.2, Section 11.11.3

4.5.1. E.U.T. Operation:

Operating Environment:	
Temperature:	26 °C
Humidity:	46.1 %
Atmospheric Pressure:	101 kPa
Final test mode:	Test Mode1

4.5.2. Test Setup Diagram:

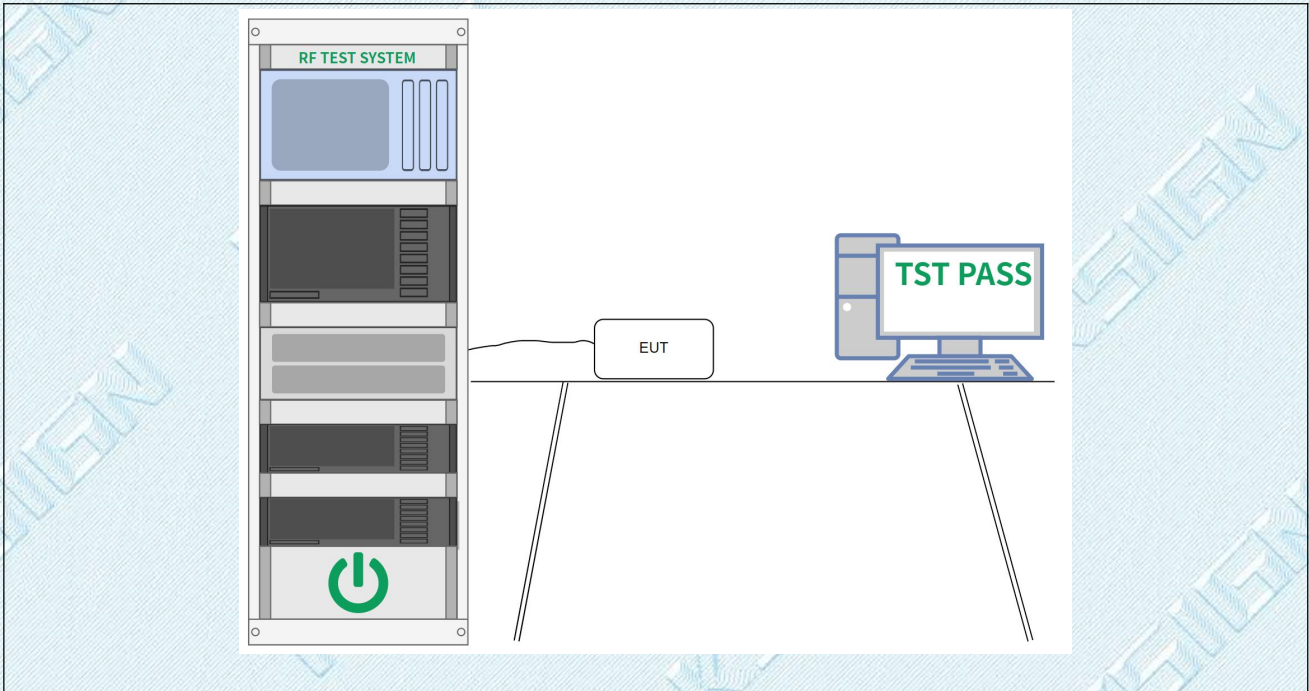

4.5.3. Test Data:

Please Refer to Appendix for Details.

4.6. Emissions around the fundamental

Test Requirement:	In addition, radiated emissions which fall in the restricted bands, as defined in § 15.205(a), must also comply with the radiated emission limits specified in § 15.209(a)(see § 15.205(c)).`		
Test Limit:	Frequency (MHz)	Field strength (microvolts/meter)	Measurement distance (meters)
	0.009-0.490	2400/F(kHz)	300
	0.490-1.705	24000/F(kHz)	30
	1.705-30.0	30	30
	30-88	100 **	3
	88-216	150 **	3
	216-960	200 **	3
	Above 960	500	3
** Except as provided in paragraph (g), fundamental emissions from intentional radiators operating under this section shall not be located in the frequency bands 54-72 MHz, 76-88 MHz, 174-216 MHz or 470-806 MHz. However, operation within these frequency bands is permitted under other sections of this part, e.g., §§ 15.231 and 15.241.			
Test Method:	Radiated emissions tests		
Procedure:	ANSI C63.10-2013 section 6.6.4		

4.6.1. E.U.T. Operation:

Operating Environment:	
Temperature:	23 °C
Humidity:	42.7 %
Atmospheric Pressure:	101 kPa
Final test mode:	Test Mode 1

4.6.2. Test Data:

Test Mode1 / Polarization: Horizontal / Band: 2.4G / BW: 1 / CH: L

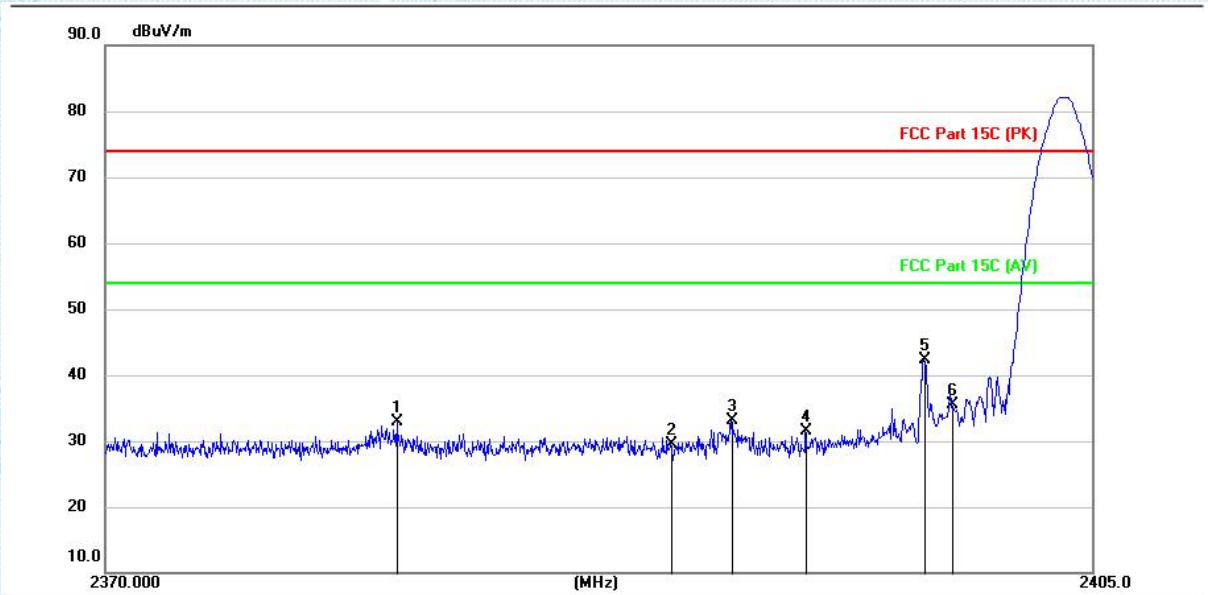

No.	Mk.	Freq. MHz	Reading Level (dBuV)	Correct Factor (dB/m)	Measurement (dBuV/m)	Limit (dBuV/m)	Over (dB)	Detector
1		2380.318	43.78	-10.92	32.86	74.00	-41.14	peak
2		2390.000	40.39	-10.92	29.47	74.00	-44.53	peak
3		2392.155	44.01	-10.92	33.09	74.00	-40.91	peak
4		2394.780	42.41	-10.91	31.50	74.00	-42.50	peak
5	*	2399.026	53.23	-10.92	42.31	74.00	-31.69	peak
6		2400.000	46.39	-10.92	35.47	74.00	-38.53	peak

Test Mode1 / Polarization: Vertical / Band: 2.4G / BW: 1 / CH: L

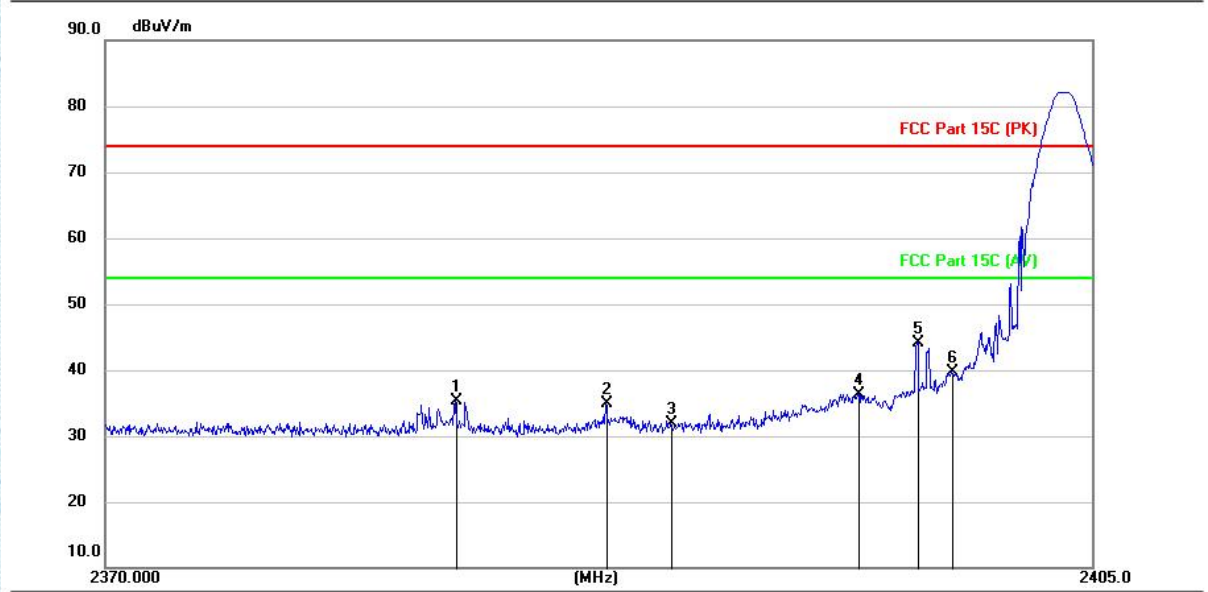

No.	Mk.	Freq. MHz	Reading Level (dBuV)	Correct Factor (dB/m)	Measurement (dBuV/m)	Limit (dBuV/m)	Over (dB)	Detector
1		2382.390	46.18	-10.92	35.26	74.00	-38.74	peak
2		2387.696	45.79	-10.92	34.87	74.00	-39.13	peak
3		2390.000	42.85	-10.92	31.93	74.00	-42.07	peak
4		2396.656	47.29	-10.92	36.37	74.00	-37.63	peak
5	*	2398.809	55.10	-10.92	44.18	74.00	-29.82	peak
6		2400.000	50.68	-10.92	39.76	74.00	-34.24	peak

Test Mode1 / Polarization: Horizontal / Band: 2.4G / BW: 1 / CH: H

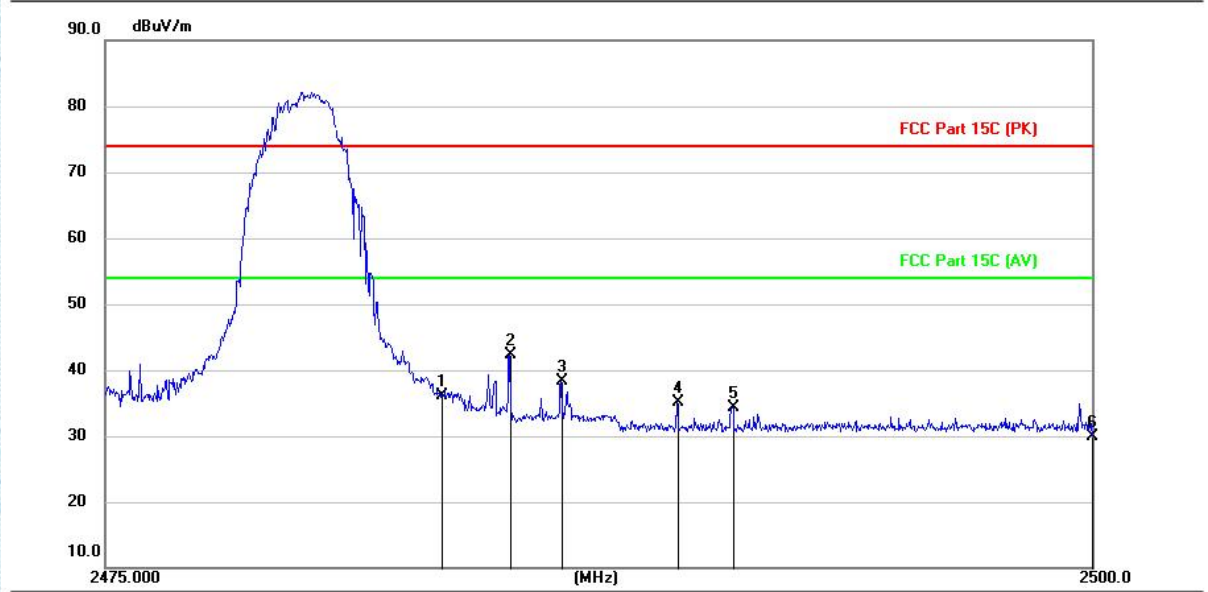

No.	Mk.	Freq. MHz	Reading Level (dBuV)	Correct Factor (dB/m)	Measurement (dBuV/m)	Limit (dBuV/m)	Over (dB)	Detector
1		2483.500	47.03	-10.88	36.15	74.00	-37.85	peak
2	*	2485.222	53.19	-10.88	42.31	74.00	-31.69	peak
3		2486.525	49.22	-10.88	38.34	74.00	-35.66	peak
4		2489.450	46.03	-10.89	35.14	74.00	-38.86	peak
5		2490.865	45.27	-10.89	34.38	74.00	-39.62	peak
6		2500.000	40.76	-10.88	29.88	74.00	-44.12	peak

Test Mode1 / Polarization: Vertical / Band: 2.4G / BW: 1 / CH: H

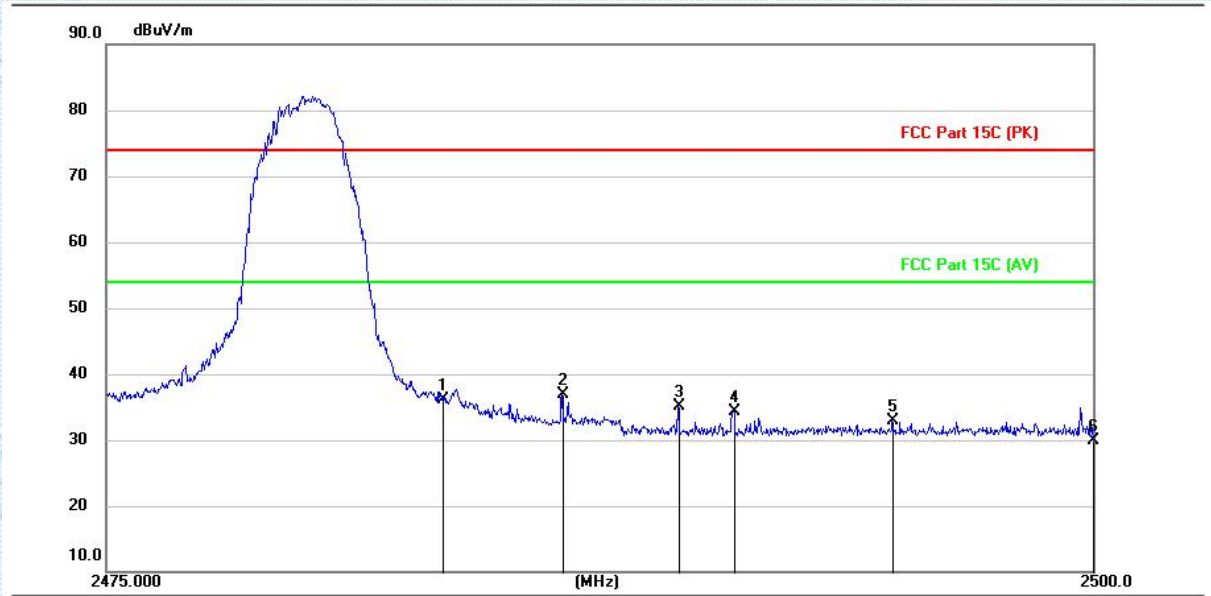

No.	Mk.	Freq. MHz	Reading Level (dBuV)	Correct Factor (dB/m)	Measurement (dBuV/m)	Limit (dBuV/m)	Over (dB)	Detector
1		2483.500	47.03	-10.88	36.15	74.00	-37.85	peak
2	*	2486.525	47.72	-10.88	36.84	74.00	-37.16	peak
3		2489.450	46.03	-10.89	35.14	74.00	-38.86	peak
4		2490.865	45.27	-10.89	34.38	74.00	-39.62	peak
5		2494.920	43.68	-10.87	32.81	74.00	-41.19	peak
6		2500.000	40.76	-10.88	29.88	74.00	-44.12	peak

Note:

1. Since the peak value is less than the limit of the AVG value, there is no AVG data.

4.7. Emissions in restricted frequency bands (below 1GHz)

Test Requirement:	In addition, radiated emissions which fall in the restricted bands, as defined in § 15.205(a), must also comply with the radiated emission limits specified in § 15.209(a)(see § 15.205(c)).`		
Test Limit:	Frequency (MHz)	Field strength (microvolts/meter)	Measurement distance (meters)
	0.009-0.490	2400/F(kHz)	300
	0.490-1.705	24000/F(kHz)	30
	1.705-30.0	30	30
	30-88	100 **	3
	88-216	150 **	3
	216-960	200 **	3
	Above 960	500	3
** Except as provided in paragraph (g), fundamental emissions from intentional radiators operating under this section shall not be located in the frequency bands 54-72 MHz, 76-88 MHz, 174-216 MHz or 470-806 MHz. However, operation within these frequency bands is permitted under other sections of this part, e.g., §§ 15.231 and 15.241.			
Test Method:	Radiated emissions tests		
Procedure:	ANSI C63.10-2013 section 6.6.4		

4.7.1. E.U.T. Operation:

Operating Environment:	
Temperature:	23 °C
Humidity:	42.7 %
Atmospheric Pressure:	101 kPa
Final test mode:	Test Mode 1

Note:

Both modes of BLE 1Mbps were tested at Low, Middle, and High channel and recorded worst mode at BLE 1Mbps Low channel.

4.7.2. Test Data:

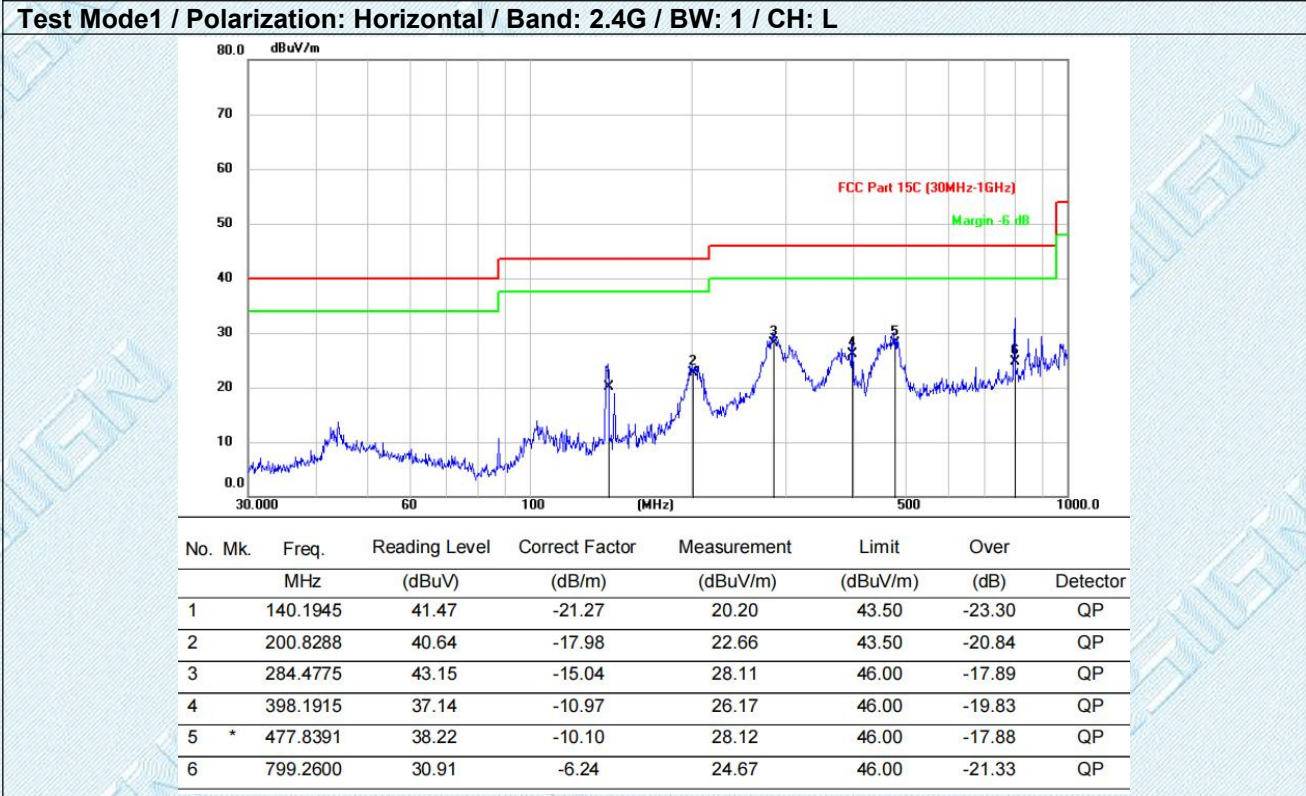

Test Mode1 / Polarization: Vertical / Band: 2.4G / BW: 1 / CH: L

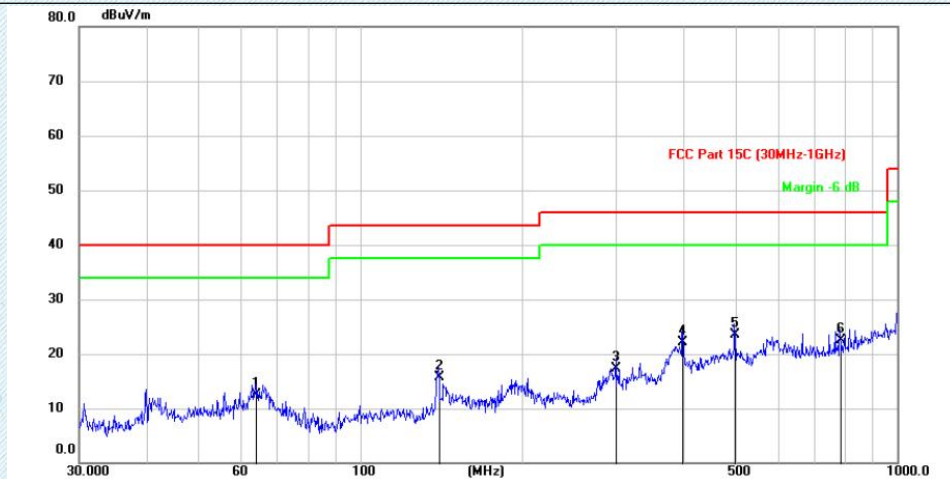

No.	Mk.	Freq. MHz	Reading Level (dBuV)	Correct Factor (dB/m)	Measurement (dBuV/m)	Limit (dBuV/m)	Over (dB)	Detector
1		63.9603	30.83	-18.42	12.41	40.00	-27.59	QP
2		140.0471	36.93	-21.27	15.66	43.50	-27.84	QP
3		300.0514	31.95	-14.66	17.29	46.00	-28.71	QP
4		398.3312	33.04	-10.96	22.08	46.00	-23.92	QP
5	*	498.2003	33.43	-9.94	23.49	46.00	-22.51	QP
6		783.4434	28.77	-6.34	22.43	46.00	-23.57	QP

4.8. Emissions in restricted frequency bands (above 1GHz)

Test Requirement:	In addition, radiated emissions which fall in the restricted bands, as defined in § 15.205(a), must also comply with the radiated emission limits specified in § 15.209(a)(see § 15.205(c)).`		
Test Limit:	Frequency (MHz)	Field strength (microvolts/meter)	Measurement distance (meters)
	0.009-0.490	2400/F(kHz)	300
	0.490-1.705	24000/F(kHz)	30
	1.705-30.0	30	30
	30-88	100 **	3
	88-216	150 **	3
	216-960	200 **	3
	Above 960	500	3
	** Except as provided in paragraph (g), fundamental emissions from intentional radiators operating under this section shall not be located in the frequency bands 54-72 MHz, 76-88 MHz, 174-216 MHz or 470-806 MHz. However, operation within these frequency bands is permitted under other sections of this part, e.g., §§ 15.231 and 15.241.		
Test Method:	Radiated emissions tests		
Procedure:	ANSI C63.10-2013 section 6.6.4		

4.8.1. E.U.T. Operation:

Operating Environment:	
Temperature:	23 °C
Humidity:	42.7 %
Atmospheric Pressure:	101 kPa
Final test mode:	Test Mode 1

4.8.2. Test Data:

Test Mode1 / Polarization: Horizontal / Band: 2.4G / BW: 1 / CH: L

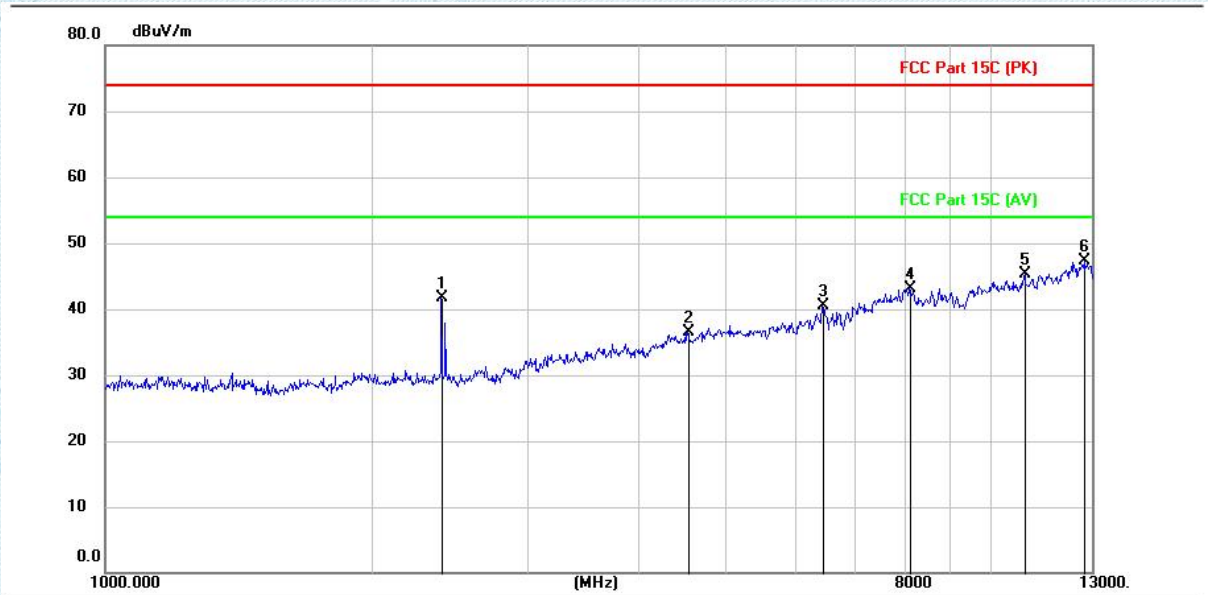

No.	Mk.	Freq. MHz	Reading Level (dBuV)	Correct Factor (dB/m)	Measurement (dBuV/m)	Limit (dBuV/m)	Over (dB)	Detector
1		2401.600	52.55	-10.91	41.64	74.00	-32.36	peak
2		4550.800	43.20	-6.62	36.58	74.00	-37.42	peak
3		6448.000	42.82	-2.28	40.54	74.00	-33.46	peak
4		8092.000	41.12	2.05	43.17	74.00	-30.83	peak
5		10933.600	39.69	5.59	45.28	74.00	-28.72	peak
6	*	12739.600	37.78	9.43	47.21	74.00	-26.79	peak

Test Mode1 / Polarization: Vertical / Band: 2.4G / BW: 1 / CH: L

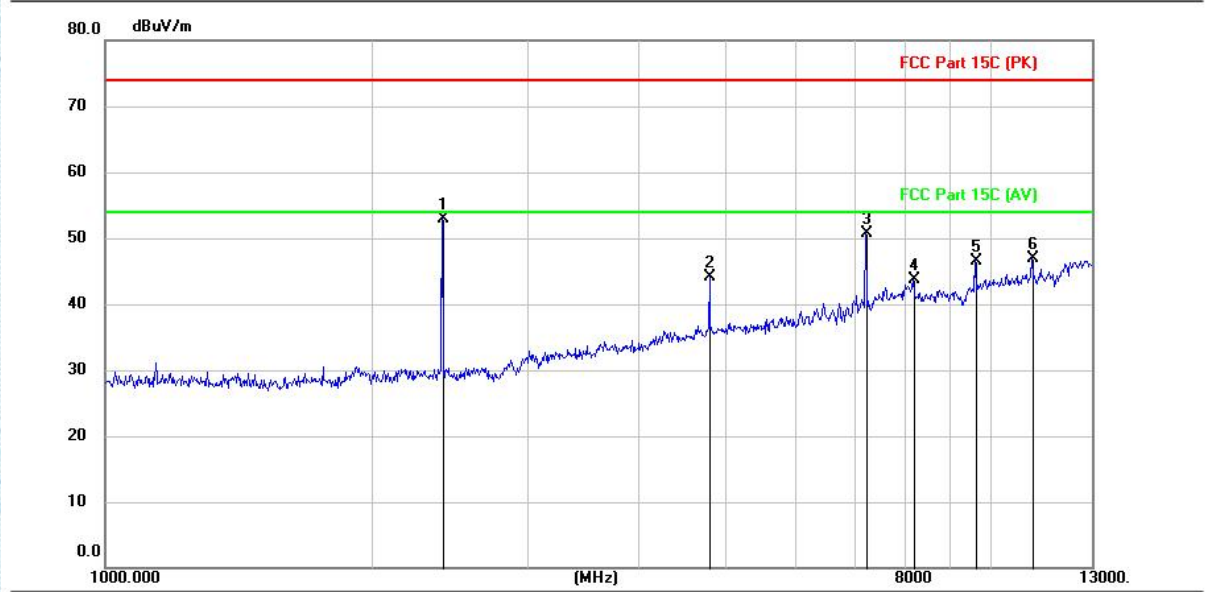

No.	Mk.	Freq. MHz	Reading Level (dBuV)	Correct Factor (dB/m)	Measurement (dBuV/m)	Limit (dBuV/m)	Over (dB)	Detector
1	*	2406.400	63.75	-10.92	52.83	74.00	-21.17	peak
2		4812.400	49.99	-5.90	44.09	74.00	-29.91	peak
3		7218.400	50.84	-0.05	50.79	74.00	-23.21	peak
4		8178.400	41.74	2.03	43.77	74.00	-30.23	peak
5		9623.200	43.22	3.23	46.45	74.00	-27.55	peak
6		11142.400	40.93	6.03	46.96	74.00	-27.04	peak

Test Mode1 / Polarization: Horizontal / Band: 2.4G / BW: 1 / CH: M

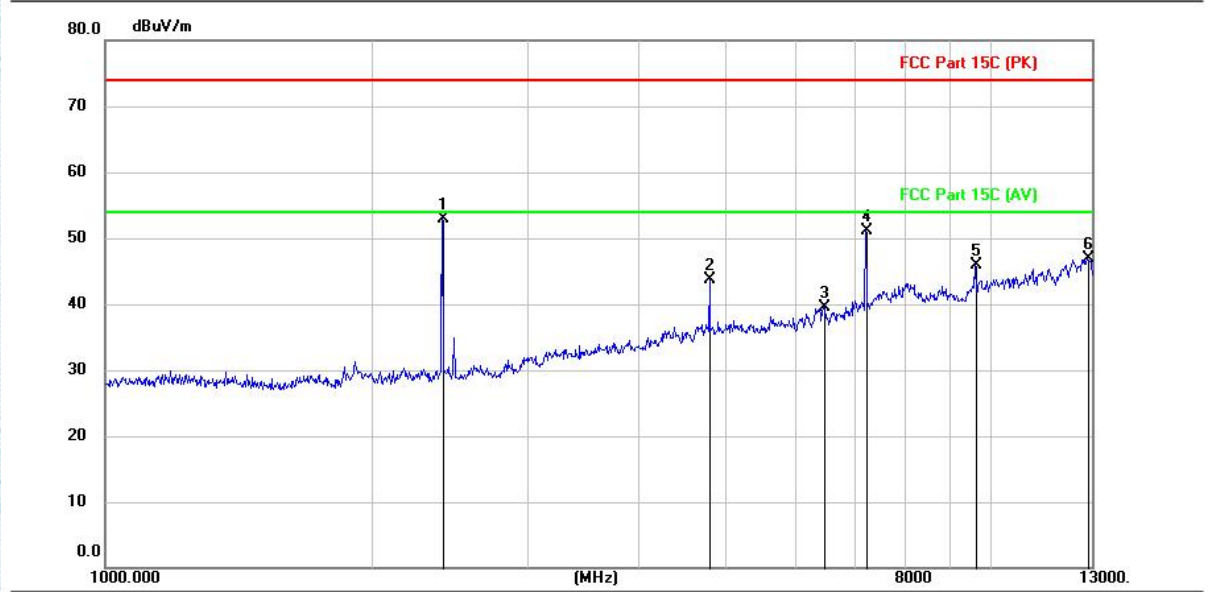

No.	Mk.	Freq. MHz	Reading Level (dBuV)	Correct Factor (dB/m)	Measurement (dBuV/m)	Limit (dBuV/m)	Over (dB)	Detector
1	*	2406.400	63.77	-10.92	52.85	74.00	-21.15	peak
2		4812.400	49.52	-5.90	43.62	74.00	-30.38	peak
3		6456.400	41.80	-2.26	39.54	74.00	-34.46	peak
4		7217.200	51.13	-0.05	51.08	74.00	-22.92	peak
5		9623.200	42.58	3.23	45.81	74.00	-28.19	peak
6		12854.800	37.17	9.65	46.82	74.00	-27.18	peak

Test Mode1 / Polarization: Vertical / Band: 2.4G / BW: 1 / CH: M

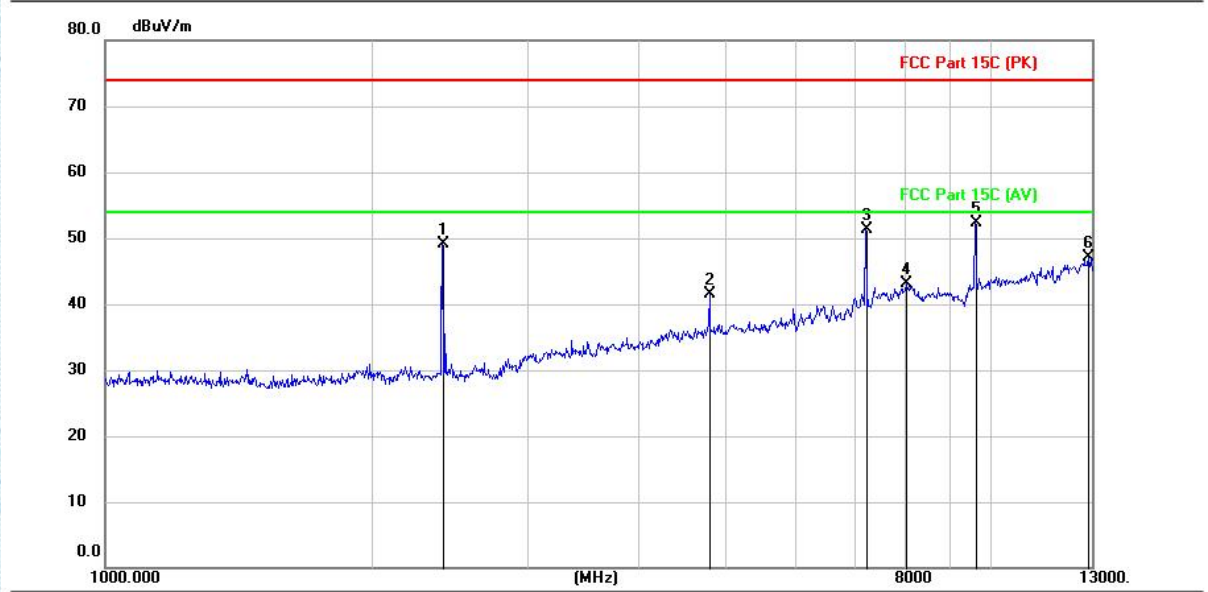

No.	Mk.	Freq. MHz	Reading Level (dBuV)	Correct Factor (dB/m)	Measurement (dBuV/m)	Limit (dBuV/m)	Over (dB)	Detector
1		2406.400	59.96	-10.92	49.04	74.00	-24.96	peak
2		4812.400	47.49	-5.90	41.59	74.00	-32.41	peak
3		7217.200	51.40	-0.05	51.35	74.00	-22.65	peak
4		8032.000	40.95	2.06	43.01	74.00	-30.99	peak
5	*	9623.200	49.07	3.23	52.30	74.00	-21.70	peak
6		12869.200	37.36	9.68	47.04	74.00	-26.96	peak

TRF EMC_R1

Add: West Side of 1/F., Building C, Zone A, Fuyuan New Factory, Jiujiu Industrial Park, Minzhu, Shatou, Shajing, Bao'an District, Shenzhen, Guangdong, China

Tel: +(86) 0755-2985 2678 Fax: +(86) 0755-2985 2397 E-mail: info@gdkesign.cn Web: www.gdkesign.com

Test Mode1 / Polarization: Horizontal / Band: 2.4G / BW: 1 / CH: H

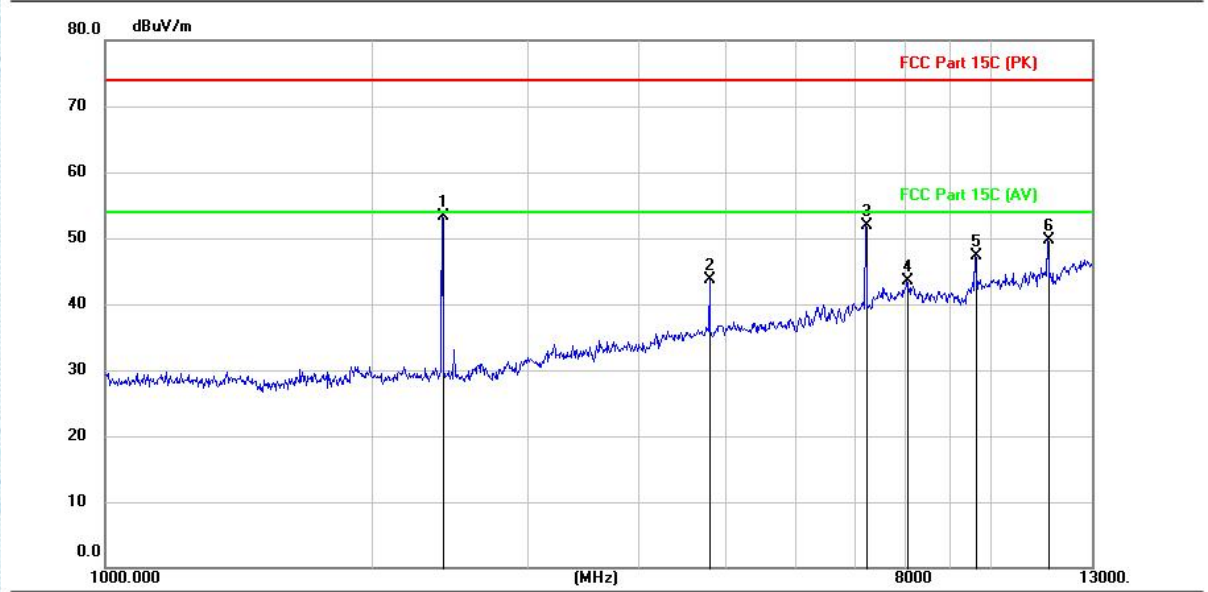

No.	Mk.	Freq. MHz	Reading Level (dBuV)	Correct Factor (dB/m)	Measurement (dBuV/m)	Limit (dBuV/m)	Over (dB)	Detector
1	*	2406.400	64.14	-10.92	53.22	74.00	-20.78	peak
2		4812.400	49.64	-5.90	43.74	74.00	-30.26	peak
3		7217.200	51.99	-0.05	51.94	74.00	-22.06	peak
4		8062.000	41.53	2.06	43.59	74.00	-30.41	peak
5		9623.200	44.05	3.23	47.28	74.00	-26.72	peak
6		11605.600	42.55	7.07	49.62	74.00	-24.38	peak

Test Mode1 / Polarization: Vertical / Band: 2.4G / BW: 1 / CH: H

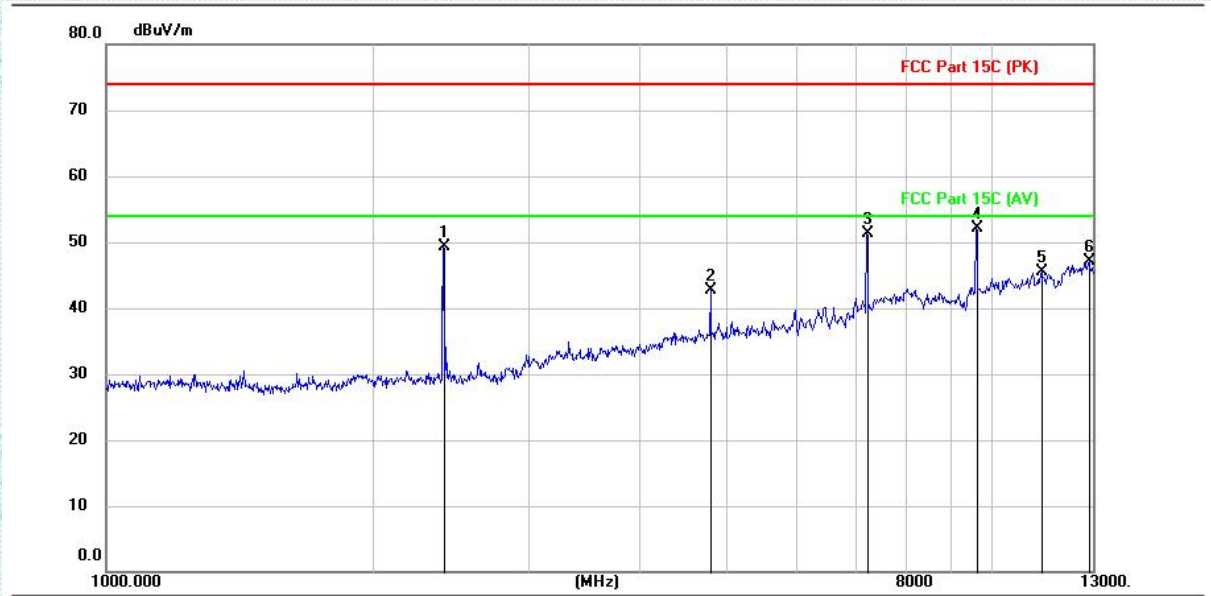

No.	Mk.	Freq. MHz	Reading Level (dBuV)	Correct Factor (dB/m)	Measurement (dBuV/m)	Limit (dBuV/m)	Over (dB)	Detector
1		2405.200	60.19	-10.92	49.27	74.00	-24.73	peak
2		4812.400	48.63	-5.90	42.73	74.00	-31.27	peak
3		7218.400	51.37	-0.05	51.32	74.00	-22.68	peak
4	*	9625.600	48.83	3.25	52.08	74.00	-21.92	peak
5		11377.600	38.83	6.58	45.41	74.00	-28.59	peak
6		12868.000	37.52	9.68	47.20	74.00	-26.80	peak

Note:

- 1.From 13GHz to 26.5GHz,the amplitude of spurious emissions which are attenuated by more than 20dB below the permissible value has no need to be reported.
- 2.Since the peak value is less than the limit of the AVG value, there is no AVG data.

5. EUT TEST PHOTOS

Conducted Emission at AC power line



Emissions in restricted frequency bands (below 1GHz)



Emissions in restricted frequency bands (above 1GHz)

6. PHOTOGRAPHS OF EUT CONSTRUCTIONAL

Refer to Appendix - Photographs of EUT Constructional Details for KS2211S4711E.

Appendix

6.1. Appendix A: DTS Bandwidth

6.1.1. Test Result

TestMode	Antenna	Freq(MHz)	DTS BW [MHz]	FL[MHz]	FH[MHz]	Limit[MHz]	Verdict
BLE_1M	Ant1	2402	0.51	2401.71	2402.22	0.5	PASS
		2440	0.51	2439.71	2440.22	0.5	PASS
		2480	0.51	2479.71	2480.22	0.5	PASS

6.1.2. Test Graphs

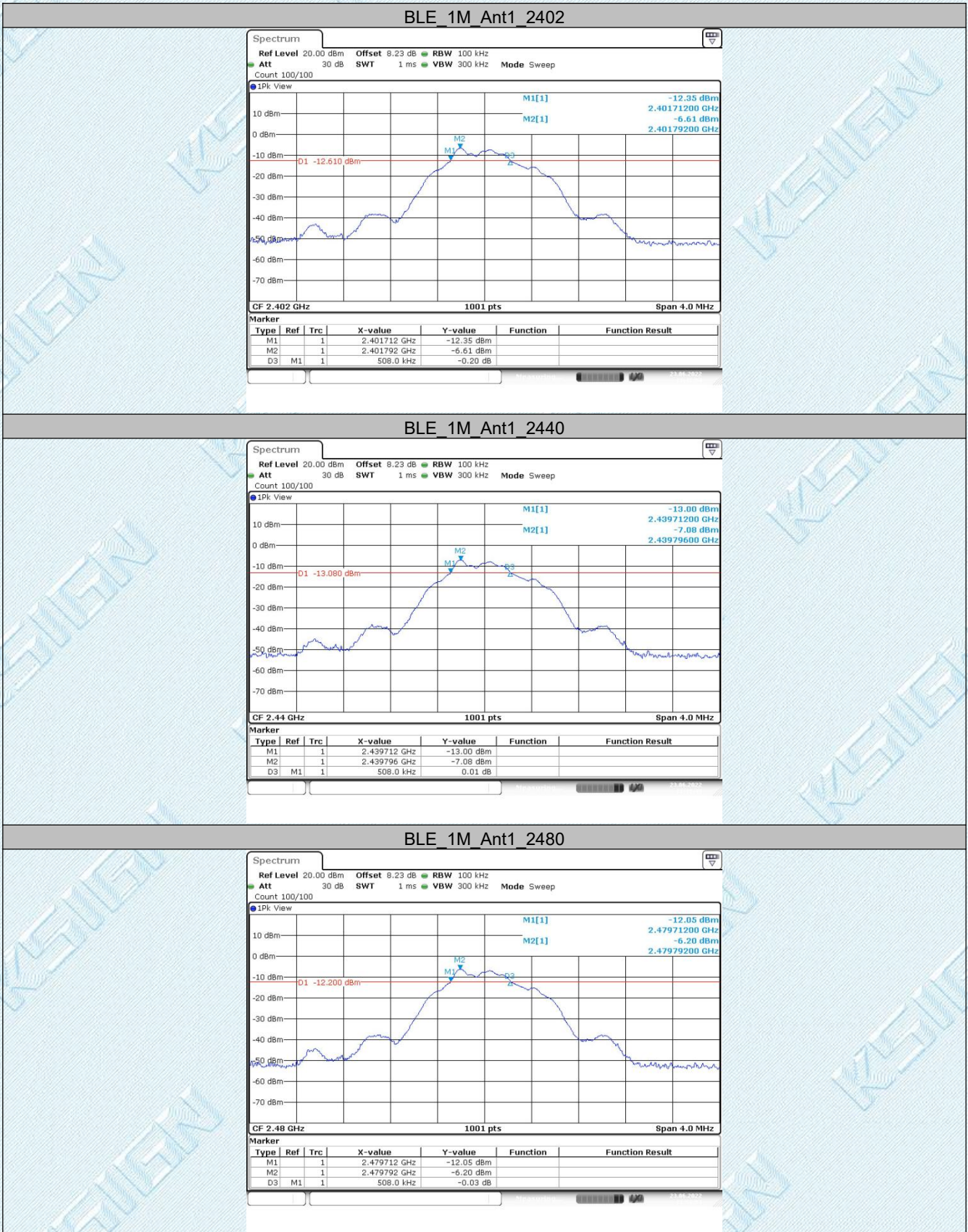

TRF EMC_R1

Add: West Side of 1/F., Building C, Zone A, Fuyuan New Factory, Jiujiu Industrial Park, Minzhu, Shatou, Shajing, Bao'an District, Shenzhen, Guangdong, China

Tel: +(86) 0755-2985 2678 Fax: +(86) 0755-2985 2397 E-mail: info@gdksign.cn Web: www.gdksign.com

6.2. Appendix B: Occupied Channel Bandwidth

6.2.1. Test Result

TestMode	Antenna	Freq(MHz)	OCB [MHz]	FL[MHz]	FH[MHz]	Limit[MHz]	Verdict
BLE_1M	Ant1	2402	1.031	2401.536	2402.567	---	---
		2440	1.031	2439.536	2440.567	---	---
		2480	1.031	2479.536	2480.567	---	---

6.2.2. Test Graphs

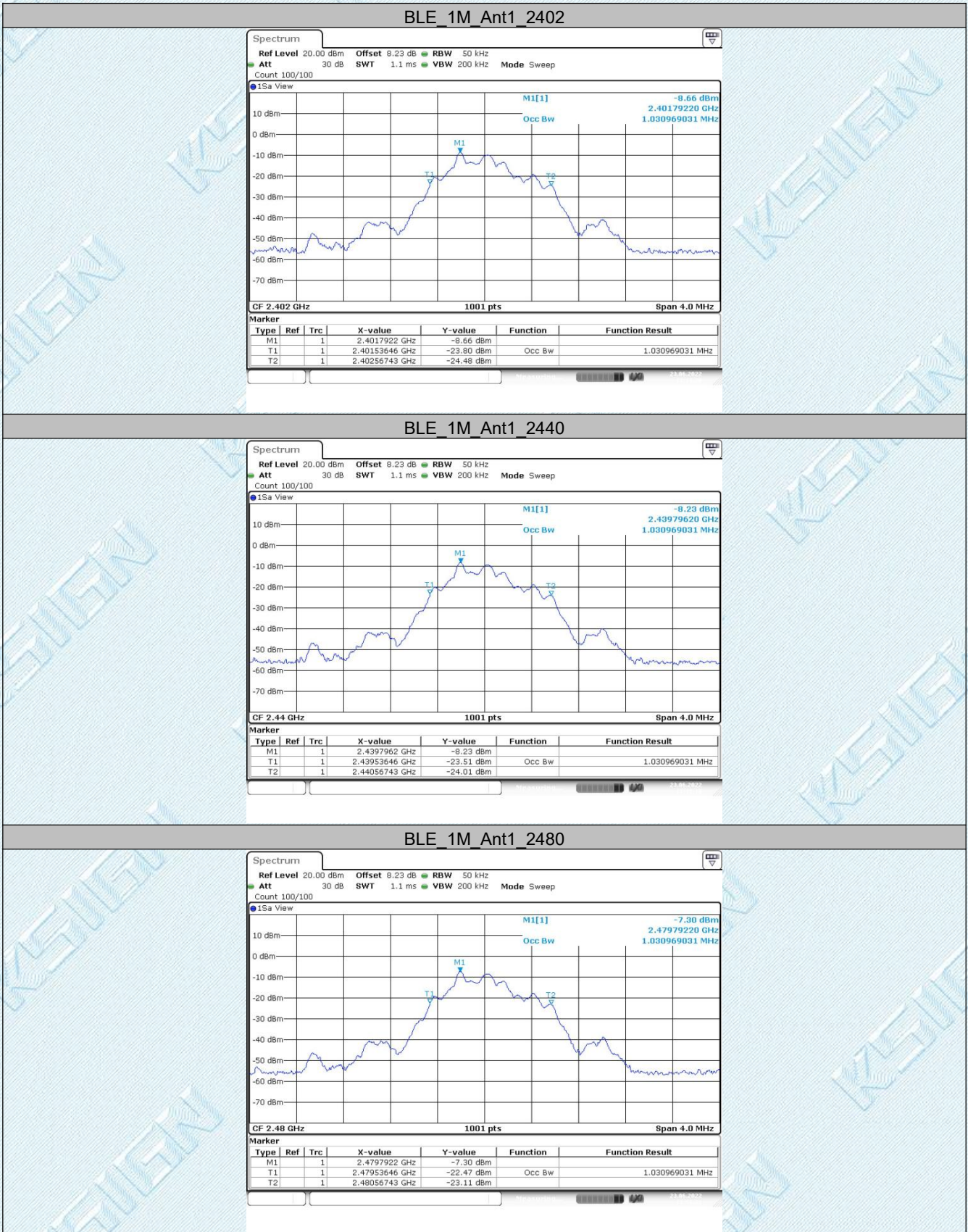

TRF EMC_R1

Add: West Side of 1/F., Building C, Zone A, Fuyuan New Factory, Jiujiu Industrial Park, Minzhu, Shatou, Shajing, Bao'an District, Shenzhen, Guangdong, China

Tel: +(86) 0755-2985 2678 Fax: +(86) 0755-2985 2397 E-mail: info@gdkesign.cn Web: www.gdkesign.com

6.3. Appendix C: Maximum conducted output power

6.3.1. Test Result Peak

TestMode	Antenna	Freq(MHz)	Conducted Peak Power[dBm]	Conducted Limit[dBm]	Verdict
BLE_1M	Ant1	2402	-7.24	≤30	PASS
		2440	-6.82	≤30	PASS
		2480	-5.87	≤30	PASS

6.3.2. Test Graphs Peak

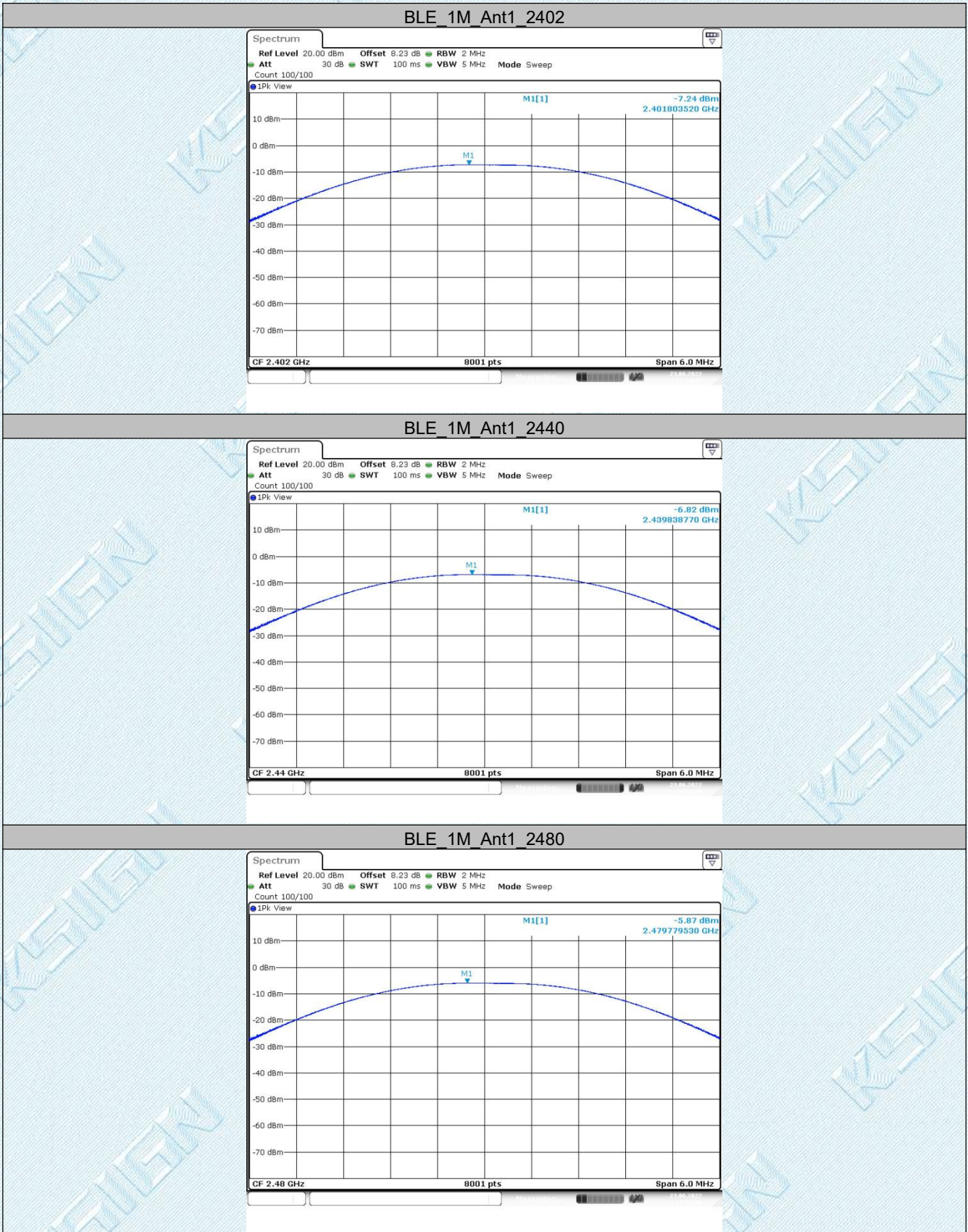

TRF EMC_R1

Add: West Side of 1/F., Building C, Zone A, Fuyuan New Factory, Jiujiu Industrial Park, Minzhu, Shatou, Shajing, Bao'an District, Shenzhen, Guangdong, China

Tel: +(86) 0755-2985 2678 Fax: +(86) 0755-2985 2397 E-mail: info@gdksign.cn Web: www.gdksign.com

6.4. Appendix D: Maximum power spectral density

6.4.1. Test Result

TestMode	Antenna	Freq(MHz)	Result[dBm/3kHz]	Limit[dBm/3kHz]	Verdict
BLE_1M	Ant1	2402	-27.19	≤8.00	PASS
		2440	-26.52	≤8.00	PASS
		2480	-25.7	≤8.00	PASS

6.4.2. Test Graphs

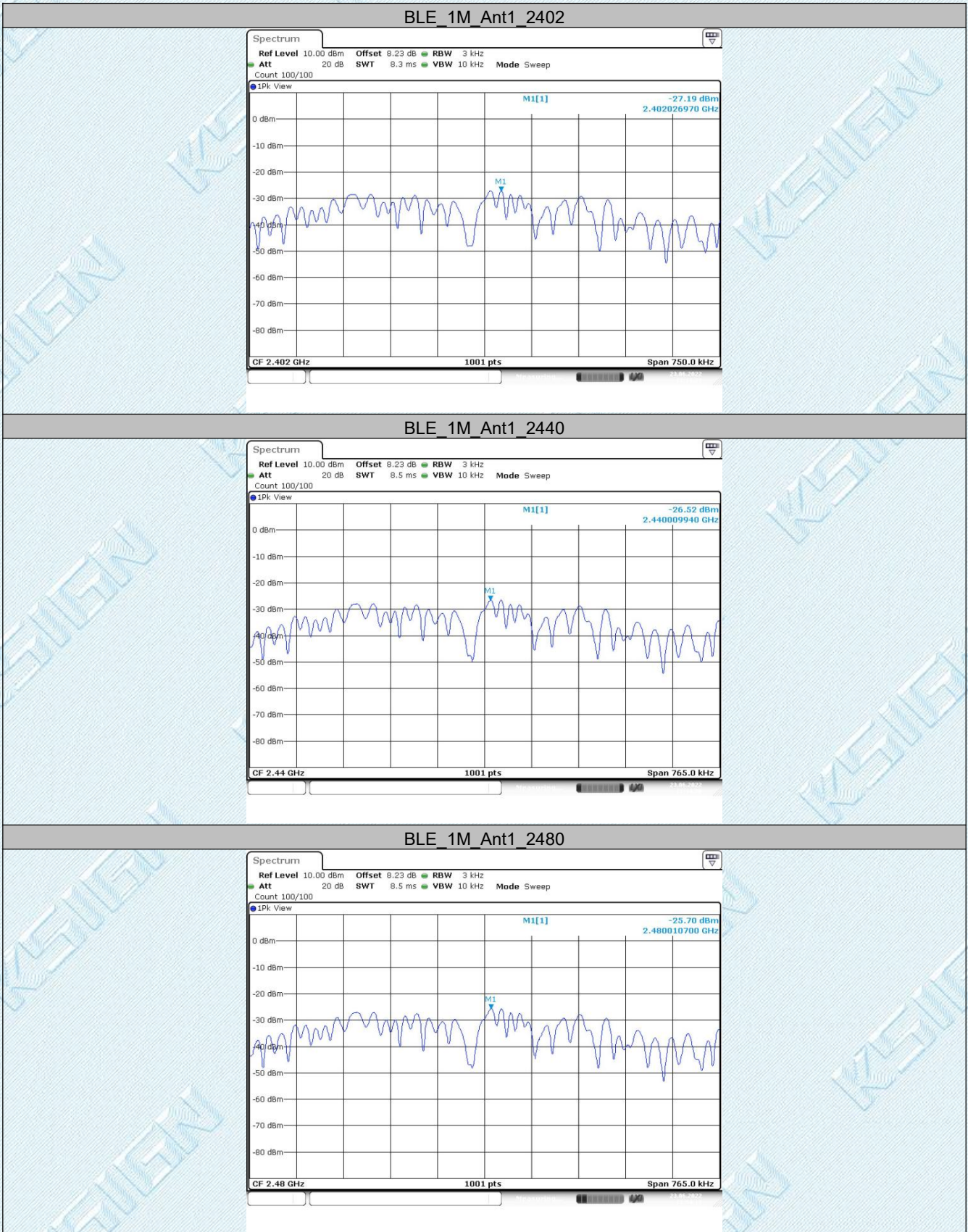

TRF EMC_R1

Add: West Side of 1/F., Building C, Zone A, Fuyuan New Factory, Jiujiu Industrial Park, Minzhu, Shatou, Shajing, Bao'an District, Shenzhen, Guangdong, China

Tel: +(86) 0755-2985 2678 Fax: +(86) 0755-2985 2397 E-mail: info@gdksign.cn Web: www.gdksign.com

6.5. Appendix F: Band edge measurements

6.5.1. Test Result

TestMode	Antenna	ChName	Freq(MHz)	RefLevel[dBm]	Result[dBm]	Limit[dBm]	Verdict
BLE_1M	Ant1	Low	2402	-7.48	-50.28	≤ -27.48	PASS
		High	2480	-6.17	-49.21	≤ -26.17	PASS

6.5.2. Test Graphs



TRF EMC_R1

Add: West Side of 1/F., Building C, Zone A, Fuyuan New Factory, Jiujiu Industrial Park, Minzhu, Shatou, Shajing, Bao'an District, Shenzhen, Guangdong, China

Tel: +(86) 0755-2985 2678 Fax: +(86) 0755-2985 2397 E-mail: info@gdkesign.cn Web: www.gdkesign.com

6.6. Appendix G: Conducted Spurious Emission

6.6.1. Test Result

TestMode	Antenna	Freq(MHz)	FreqRange [MHz]	RefLevel [dBm]	Result[dBm]	Limit[dBm]	Verdict
BLE_1M	Ant1	2402	30~1000	-7.48	-59.02	≤-27.48	PASS
			1000~26500	-7.48	-54.8	≤-27.48	PASS
		2440	30~1000	-7.05	-59.91	≤-27.05	PASS
			1000~26500	-7.05	-54.44	≤-27.05	PASS
		2480	30~1000	-6.17	-59.38	≤-26.17	PASS
			1000~26500	-6.17	-54.25	≤-26.17	PASS

6.6.2. Test Graphs

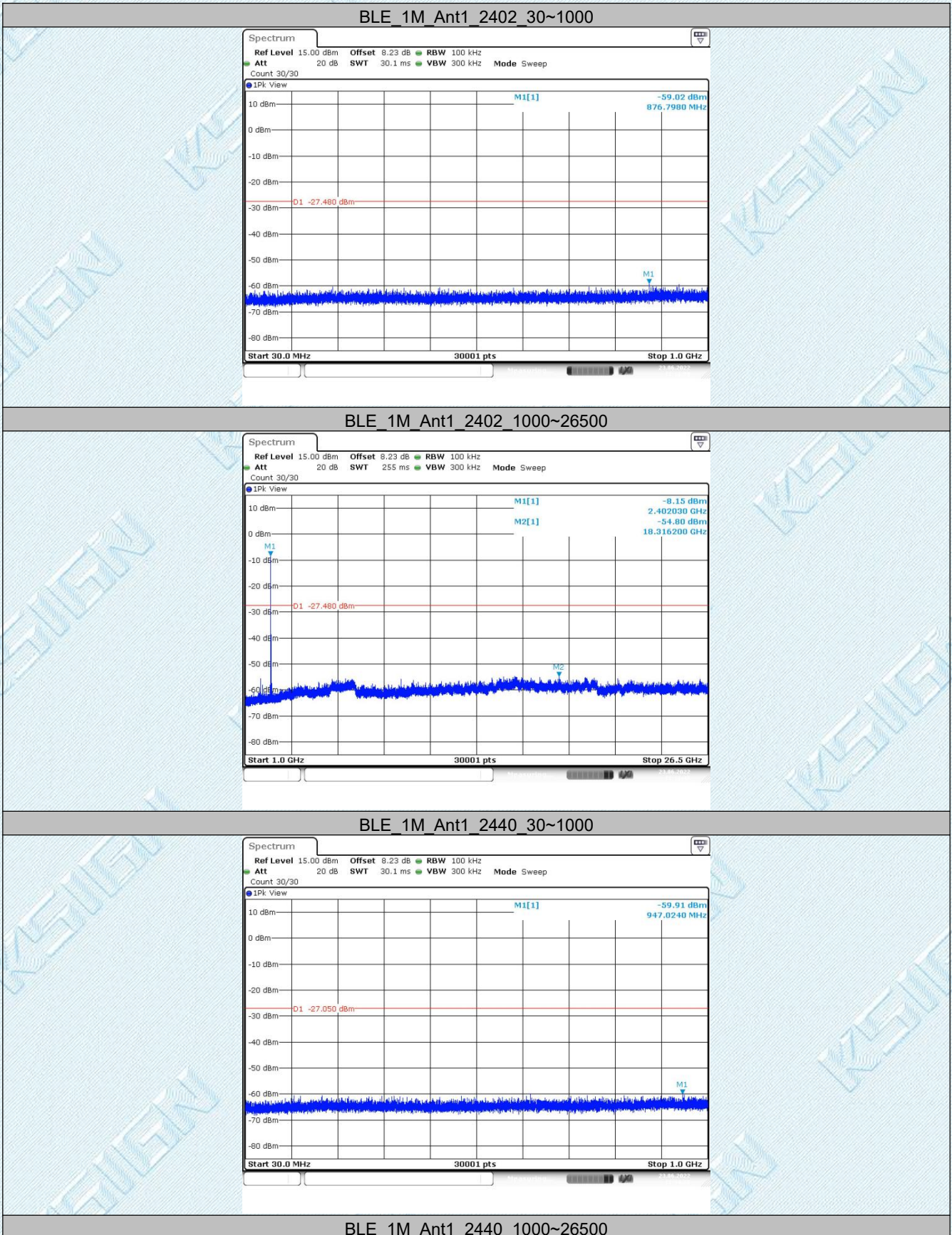

TRF EMC_R1

Add: West Side of 1/F., Building C, Zone A, Fuyuan New Factory, Jiujiu Industrial Park, Minzhu, Shatou, Shajing, Bao'an District, Shenzhen, Guangdong, China

Tel: +(86) 0755-2985 2678 Fax: +(86) 0755-2985 2397 E-mail: info@gdkesign.cn Web: www.gdkesign.com

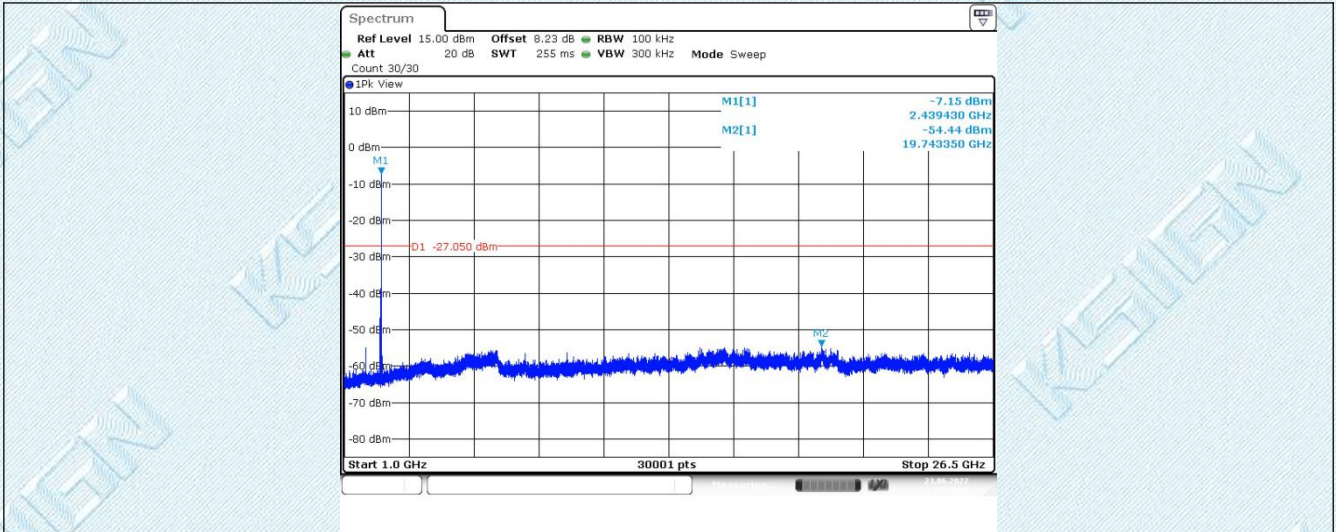

BLE 1M Ant1 2480 30~1000

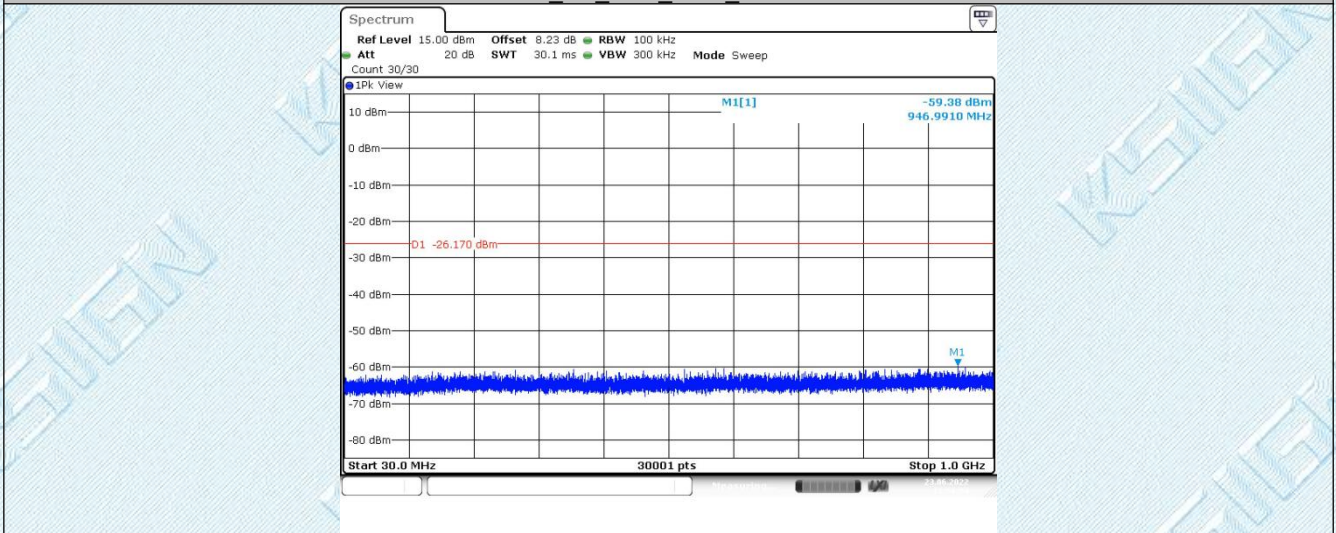

BLE 1M Ant1 2480 1000~26500

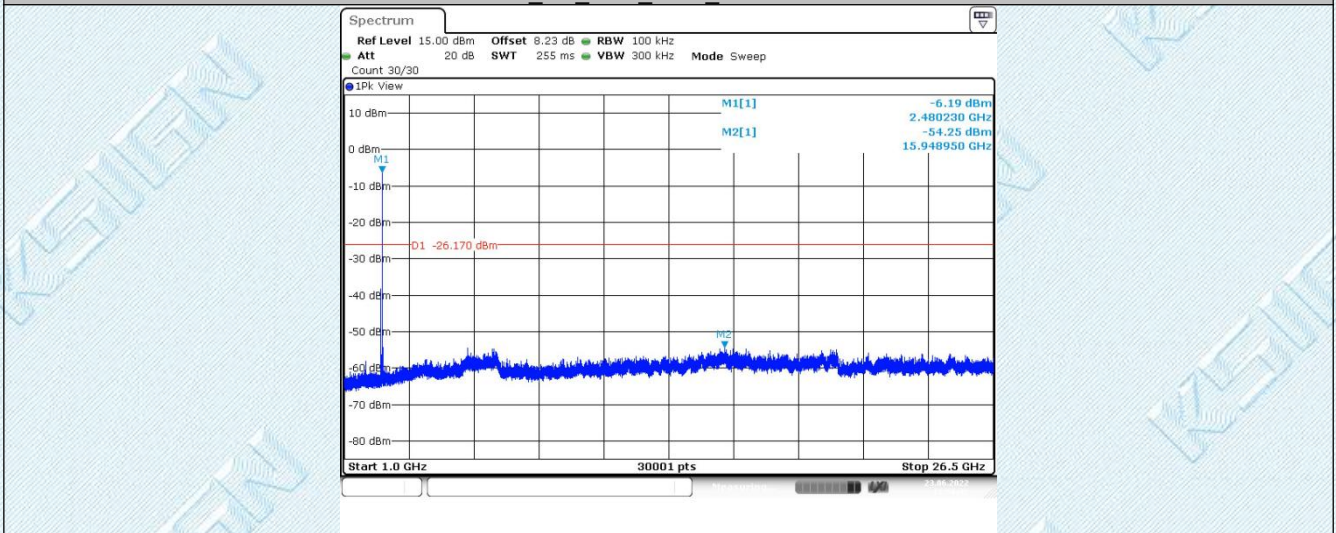

6.7. Appendix H: Duty Cycle

6.7.1. Test Result

TestMode	Antenna	Freq(MHz)	ON Time [ms]	Period [ms]	DC [%]	Factor	Limit	Verdict
BLE_1M	Ant1	2440	0.09	0.63	14.29	8.45	---	---

6.7.2. Test Graphs

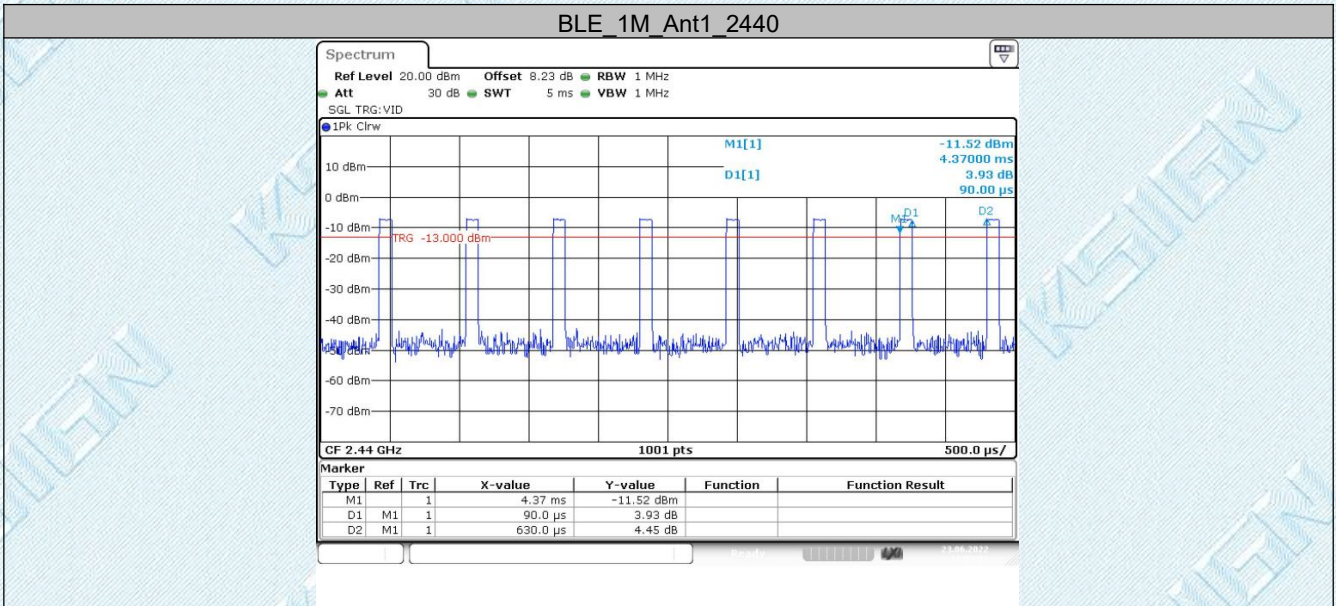

--THE END--