



Valued Quality. Delivered.

## TEST REPORT

**Report No.: 16040454HKG-002**

**Better Sourcing Worldwide, Ltd.**

Application  
For  
Certification  
(Original Grant)  
**(FCC ID: 2AHY6-49RX)**

Superregenerative Receiver

Prepared and Checked by:

Approved by:

Signed On File  
Chak Chun Yin, Ray  
Assistant Engineer

---

Chow Chi Ming, Billy  
Manager  
Date: April 19, 2016

- Intertek's standard Terms and Conditions can be obtained at our website <http://www.intertek.com/terms/>.
- The test report only allows to be revised within the retention period unless further standard or the requirement was noticed.
- This report is for the exclusive use of Intertek's Client and is provided pursuant to the agreement between Intertek and its Client. Intertek's responsibility and liability are limited to the terms and conditions of the agreement. Intertek assumes no liability to any party, other than to the Client in accordance with the agreement, for any loss, expense or damage occasioned by the use of this report. Only the Client is authorized to permit copying or distribution of this report and then only in its entirety. Any use of the Intertek name or one of its marks for the sale or advertisement of the tested material, product or service must first be approved in writing by Intertek. The observations and test results in this report are relevant only to the sample tested. This report by itself does not imply that the material, product, or service is or has ever been under an Intertek certification program.
- © 2016 Intertek

**Intertek Testing Services Hong Kong Ltd.**

2/F., Garment Centre, 576 Castle Peak Road, Kowloon, Hong Kong.  
Tel: (852) 2173 8888 Fax: (852) 2785 5487 Website: [www.hk.intertek-etlsemko.com](http://www.hk.intertek-etlsemko.com)

## INTERTEK TESTING SERVICES

---

### GENERAL INFORMATION

Grantee:	Better Sourcing Worldwide, Ltd.
Grantee Address:	14/F., Yale Industrial Centre, 61-63 Au Pui Wan Street, Fotan, Shatin, N.T., Hong Kong.
Contact Person:	Teresa Hui
Tel:	26930313
Fax:	26930030
e-mail:	teresahui@bettersourcing.com / bsw@bettersourcing.com
Manufacturer:	Centresky Crafts (Shantou) Co., Ltd.
Manufacturer Address:	Da Pu Mei Industrial Park, Huai Nan, Lian Xia, Cheng Hai District, Shan Tou City, Guang Dong, China.
Brand Name:	Little Tikes
Model:	9203
Asst. No.:	9207
Type of EUT:	Superregenerative Receiver
Description of EUT:	RC Car - Racing Car
Serial Number:	N/A
FCC ID:	2AHY6-49RX
Date of Sample Submitted:	April 08, 2016
Date of Test:	April 08, 2016 to April 14, 2016
Report No.:	16040454HKG-002
Report Date:	April 19, 2016
Environmental Conditions:	Temperature: +10 to 40°C Humidity: 10 to 90%

---

## INTERTEK TESTING SERVICES

---

### SUMMARY OF TEST RESULT

TEST SPECIFICATION	REFERENCE	RESULTS
Receiver / Digital Device Radiated Emissions	15.109	Pass

The equipment under test is found to be complying with the following standards:  
FCC Part 15, October 1, 2014 Edition

---

# INTERTEK TESTING SERVICES

---

## Table of Contents

1.0	<b><u>General Description</u></b> .....	1
1.1	Product Description .....	1
1.2	Related Submittal(s) Grants .....	1
1.3	Test Methodology .....	1
1.4	Test Facility .....	1
2.0	<b><u>System Test Configuration</u></b> .....	2
2.1	Justification.....	2
2.2	EUT Exercising Software .....	2
2.3	Special Accessories.....	2
2.4	Measurement Uncertainty .....	2
2.5	Support Equipment List and Description.....	2
3.0	<b><u>Emission Results</u></b> .....	3
3.1	Field Strength Calculation .....	3
3.2	Radiated Emission Configuration Photograph .....	4
3.3	Radiated Emission Data .....	4
4.0	<b><u>Equipment Photographs</u></b> .....	6
5.0	<b><u>Product Labelling</u></b> .....	6
6.0	<b><u>Technical Specifications</u></b> .....	6
7.0	<b><u>Instruction Manual</u></b> .....	6
8.0	<b><u>Miscellaneous Information</u></b> .....	7
8.1	Stabilization Waveform .....	7
8.2	Discussion of Pulse Desensitization .....	8
8.3	Calculation of Average Factor .....	8
8.4	Emissions Test Procedures .....	9
9.0	<b><u>Equipment List</u></b> .....	12

---

## INTERTEK TESTING SERVICES

---

### 1.0 General Description

#### 1.1 Product Description

The equipment under test (EUT) is a superregenerative receiver of a RC car operating at 49.860 MHz. The EUT is powered by 3 x “AAA” size batteries. The EUT has an ON/OFF switch.

After switching ON the EUT and the transmitter of the RC car, the EUT can be controlled to move forward, reverse, left and right by the transmitter.

Antenna Type: External, Integral

For electronic filing, the brief circuit description is saved with filename: descri.pdf.

#### 1.2 Related Submittal(s) Grants

This is a single application for certification of a receiver.

#### 1.3 Test Methodology

Radiated emission measurements was performed according to the procedures in ANSI C63.4 (2009). All radiated measurements were performed in an 3m Chamber. Preliminary scans were performed in the 3m Chamber only to determine worst case modes. All radiated tests were performed at an antenna to EUT distance of 3 meters, unless stated otherwise in the “**Justification Section**” of this Application.

#### 1.4 Test Facility

The 3m Chamber facility used to collect the radiated data is located at Workshop No. 3, G/F., World-Wide Industrial Centre, 43-47 Shan Mei Street, Fo Tan, Sha Tin, N.T., Hong Kong. This test facility and site measurement data have been placed on file with the FCC.

---

## INTERTEK TESTING SERVICES

---

### 2.0 **System Test Configuration**

#### 2.1 Justification

The system was configured for testing in a typical fashion (as a customer would normally use it), and in the confines as outlined in ANSI C63.4 (2009).

The device was powered by new 3x1.5V AA size batteries.

For maximizing emissions, the EUT was rotated through 360°, the antenna height was varied from 1 meter to 4 meters above the ground plane, and the antenna polarization was changed. This step by step procedure for maximizing emissions led to the data reported in Exhibit 3.0.

The unit was operated standalone and placed in the center of the turntable.

The equipment under test (EUT) was configured for testing in a typical fashion (as a customer would normally use it). The EUT was mounted to a plastic stand if necessary and placed on the wooden turntable, which enabled the engineer to maximize emissions through its placement in the three orthogonal axes.

#### 2.2 EUT Exercising Software

There was no special software to exercise the device. Once the unit is powered up, it receives the RF signal continuously.

#### 2.3 Special Accessories

There are no special accessories necessary for compliance of this product.

#### 2.4 Measurement Uncertainty

When determining of the test conclusion, the Measurement Uncertainty of test has been considered.

#### 2.5 Support Equipment List and Description

N/A.

---

## INTERTEK TESTING SERVICES

---

### 3.0 Emission Results

Data is included of the worst case configuration (the configuration which resulted in the highest emission levels). A sample calculation, configuration photographs and data tables of the emissions are included.

#### 3.1 Field Strength Calculation

The field strength is calculated by adding the Antenna Factor and Cable Factor, and subtracting the Amplifier Gain (if any), Average Factor (optional) from the measured reading. The basic equation with a sample calculation is as follows:

$$FS = RA + AF + CF - AG - AV$$

where

- FS = Field Strength in dB $\mu$ V/m
- RA = Receiver Amplitude (including preamplifier) in dB $\mu$ V
- CF = Cable Attenuation Factor in dB
- AF = Antenna Factor in dB
- AG = Amplifier Gain in dB
- AV = Average Factor in dB

In the following table(s), the reading shown on the data table reflects the preamplifier gain. An example for the calculations in the following table is as follows:

$$FS = RR + LF$$

where

- FS = Field Strength in dB $\mu$ V/m
- RR = RA - AG - AV in dB $\mu$ V
- LF = CF + AF in dB

Assume a receiver reading of 52.0 dB $\mu$ V is obtained. The antenna factor of 7.4 dB and cable factor of 1.6 dB are added. The amplifier gain of 29 dB and average factor of 5 dB are subtracted, giving a field strength of 32 dB $\mu$ V/m. This value in dB $\mu$ V/m was converted to its corresponding level in  $\mu$ V/m.

$$\begin{aligned} RA &= 52.0 \text{ dB}\mu\text{V/m} & RR &= 18.0 \text{ dB}\mu\text{V} \\ AF &= 7.4 \text{ dB} & LF &= 9.0 \text{ dB} \\ CF &= 1.6 \text{ dB} \\ AG &= 29.0 \text{ dB} \\ AV &= 5.0 \text{ dB} \\ FS &= RR + LF \\ FS &= 18 + 9 = 27 \text{ dB}\mu\text{V/m} \end{aligned}$$

$$\text{Level in } \mu\text{V/m} = \text{Common Antilogarithm } [(27 \text{ dB}\mu\text{V/m})/20] = 22.4 \mu\text{V/m}$$

## INTERTEK TESTING SERVICES

---

### 3.2 Radiated Emission Configuration Photograph

The worst case in radiated emission was found at 51.460 MHz

For electronic filing, the worst case radiated emission configuration photographs are saved with filename: radiated photos.pdf.

### 3.3 Radiated Emission Data

The data on the following page lists the significant emission frequencies, the limit and the margin of compliance. Numbers with a minus sign are below the limit.

Judgment: Passed by 4.3 dB



---

---

## INTERTEK TESTING SERVICES

---

---

Applicant: Better Sourcing Worldwide, Ltd.  
Model: 9203  
Worst-Case Operating Mode: Rx

Date of Test: April 14, 2016

Table 1  
**Radiated Emissions**  
**Pursuant to FCC Part 15-Section 15.109-Requirement**

Polarization	Frequency (MHz)	Reading (dB $\mu$ V)	Pre-amp (dB)	Antenna Factor (dB)	Net at 3m (dB $\mu$ V/m)	Limit at 3m (dB $\mu$ V/m)	Margin (dB)
V	49.240	38.4	16	11.0	33.4	40.0	-6.6
V	49.950	39.3	16	11.0	34.3	40.0	-5.7
V	51.460	40.7	16	11.0	35.7	40.0	-4.3
V	51.970	38.4	16	11.0	33.4	40.0	-6.6
V	52.870	36.4	16	11.0	31.4	40.0	-8.6
V	98.586	25.5	16	12.0	21.5	43.5	-22.0
V	99.186	26.6	16	12.0	22.6	43.5	-20.9
H	146.797	24.5	16	14.0	22.5	43.5	-21.0
H	150.678	25.6	16	14.0	23.6	43.5	-19.9
H	195.866	24.7	16	16.0	24.7	43.5	-18.8
H	199.635	22.4	16	16.0	22.4	43.5	-21.1
H	202.836	24.4	16	16.0	24.4	43.5	-19.1

- NOTES: 1. Peak Detector Data unless otherwise stated.
2. All measurements were made at 3 meters. Harmonic emissions not detected at the 3-meter distances were measured at 0.3-meter and an inverse proportional extrapolation was performed to compare the signal level to the 3-meter limit. No other harmonic emissions than those reported were detected at a test distance of 0.3-meter.
3. Negative sign in the column shows value below limit.
4. Horn antenna is used for the emission over 1000MHz.
5. Measurement Uncertainty is  $\pm 5.3$ dB at a level of confidence of 95%.

## INTERTEK TESTING SERVICES

---

### 4.0 **Equipment Photographs**

For electronic filing, the photographs are saved with filename: external photos.pdf and internal photos.pdf.

### 5.0 **Product Labelling**

For electronics filing, the FCC ID label artwork and the label location are saved with filename: label.pdf.

### 6.0 **Technical Specifications**

For electronic filing, the block diagram and schematic of the tested EUT are saved with filename: block.pdf and circuit.pdf respectively.

### 7.0 **Instruction Manual**

For electronic filing, a preliminary copy of the Instruction Manual is saved with filename: manual.pdf.

This manual will be provided to the end-user with each unit sold/leased in the United States.

# INTERTEK TESTING SERVICES

## 8.0 Miscellaneous Information

This miscellaneous information includes details of the stabilizing process (including a plot of the stabilized waveform), the test procedure and calculation of the factors such as pulse desensitization and averaging factor.

### 8.1 Stabilization Waveform

Previous to the testing, the superregenerative receiver was stabilized as outlined in the test procedure. For the electronic filing, the plot saved with filename: superreg.pdf show the fundamental emission when a signal generator was used to stabilize the receiver. Please note that the antenna was placed as close as possible to the EUT for clear demonstration of the waveform and that accurate readings are not possible from this plot.

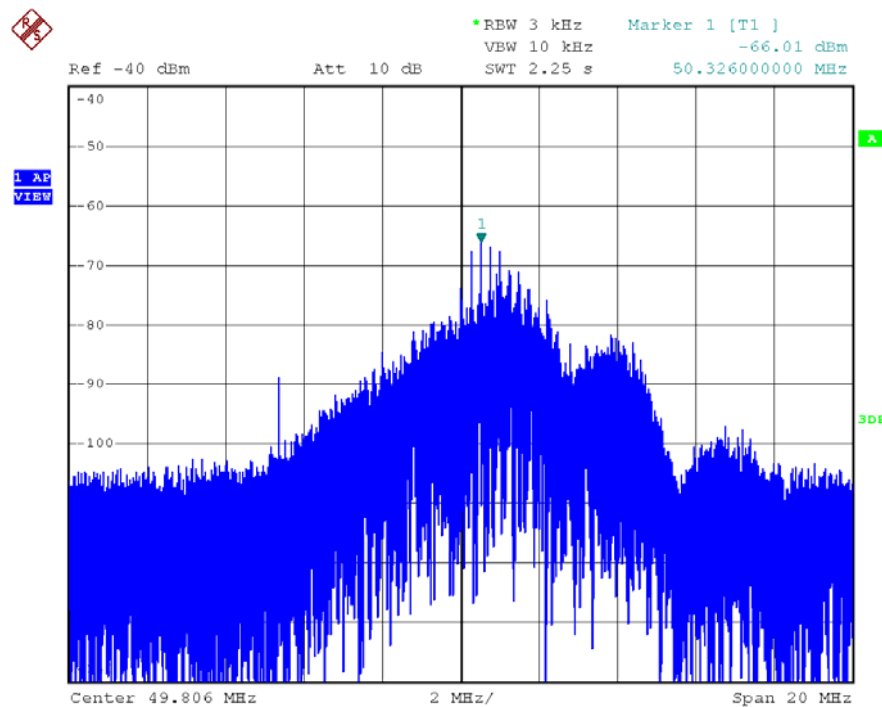

## INTERTEK TESTING SERVICES

---

### 8.2 Discussion of Pulse Desensitization

This device is a Superregenerative receiver. No desensitization of the measurement equipment is required as the received signals are continuously.

### 8.3 Calculation of Average Factor

This device is a Superregenerative receiver. It is not necessary to apply average factor to the measurement result.

## INTERTEK TESTING SERVICES

---

### 8.4 Emissions Test Procedures

The following is a description of the test procedure used by Intertek Testing Services Hong Kong Ltd. in the measurements of Superregenerative receivers operating under the Part 15, Subpart B rules.

The test set-up and procedures described below are designed to meet the requirements of ANSI C63.4 (2009). A typical or an unmodulated CW signal at the operating frequency of the EUT has been supplied to the EUT for all measurements. Such a signal is supplied by a signal generator and an antenna in close proximity to the EUT. The signal level is sufficient to stabilize the local oscillator of the EUT.

The equipment under test (EUT) is placed on a wooden turntable which is four feet in diameter and approximately one meter in height above the groundplane. During the radiated emissions test, the turntable is rotated and any cables leaving the EUT are manipulated to find the configuration resulting in maximum emissions. The antenna height and polarization are also varied during the testing to search for maximum signal levels. The height of the antenna is varied from one to four meters.

Detector function for radiated emissions is in peak mode. Average readings, when required, are taken by measuring the duty cycle of the equipment under test and subtracting the corresponding amount in dB from the measured peak readings.

The frequency range scanned is from 30 MHz to 1000 MHz.

## INTERTEK TESTING SERVICES

---

### 8.4 Emissions Test Procedures (cont'd)

The EUT is warmed up for 15 minutes prior to the test.

AC power to the unit is varied from 85% to 115% nominal and variation in the fundamental emission field strength is recorded. If battery powered, a new, fully charged battery is used.

Conducted measurements were made as described in ANSI C63.4 (2009).

The IF bandwidth used for measurement of radiated signal strength was 10 kHz for emission below 30 MHz and 120 kHz for emission from 30 MHz to 1000 MHz. Above 1000 MHz, a resolution bandwidth of 1 MHz is used.

Measurements are normally conducted at a measurement distance of three meters. All measurements are extrapolated to three meters using inverse scaling, unless otherwise reported. Measurements taken at a closer distance are so marked.

## INTERTEK TESTING SERVICES

### 8.4.1 Radiated Emission Test Setup

The figure below shows the test setup, which is utilized to make these measurements.

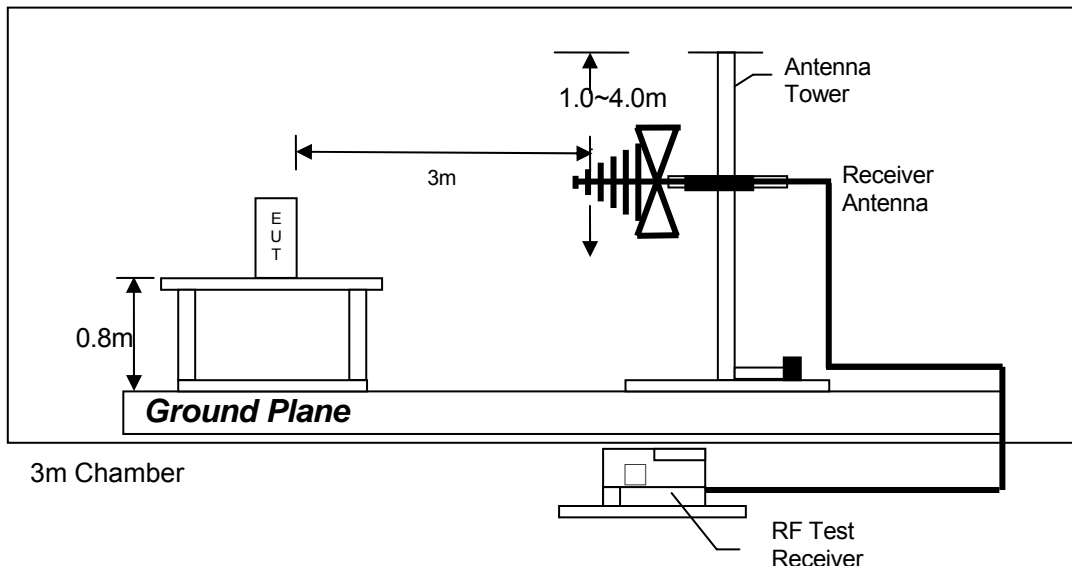

Test setup of radiated emissions up to 1GHz

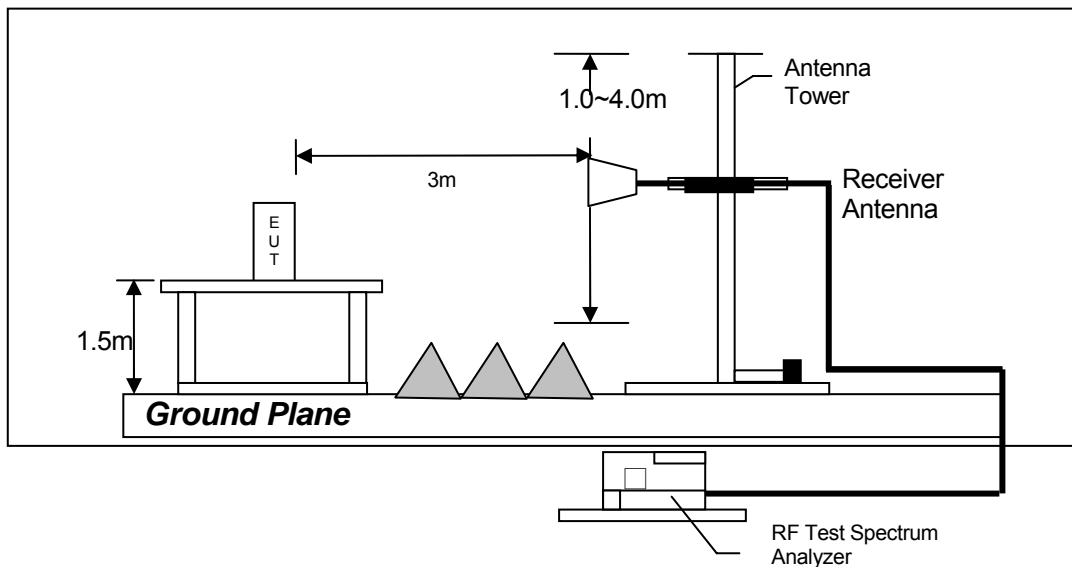

Test setup of radiated emissions above 1GHz

## INTERTEK TESTING SERVICES

---

### 9.0 Equipment List

#### 1) Radiated Emissions Test

Equipment	EMI Test Receiver	Spectrum Analyzer	Biconical Antenna
Registration No.	EW-3095	EW-2466	EW-0571
Manufacturer	R&S	R&S	EMCO
Model No.	ESCI	FSP30	3104C
Calibration Date	Nov. 05, 2015	Sep. 16, 2015	Jun. 23, 2015
Calibration Due Date	Nov. 05, 2016	Aug. 20, 2016	Dec. 23, 2016

Equipment	Log Periodic Antenna	Signal Generator	Double Ridged Guide Antenna
Registration No.	EW-0446	EW-2420	EW-1133
Manufacturer	EMCO	AGILENTTECH	EMCO
Model No.	3146	E4421B	3115
Calibration Date	Nov. 10, 2014	Apr.16, 2015	Nov. 05, 2015
Calibration Due Date	May 10, 2016	Apr.16, 2016	May 05, 2017

END OF TEST REPORT