



## Manuel & Operating Instructions Standard Sensor Models M2008 (Propane)

INTENDED USE OF THE M2008 SENSOR IS TO MEASURE THE AMOUNT OF LIQUID PROPANE INSIDE A PROPANE TANK MEETING THE SPECIFATIONS BELOW, UNDER THE CONDITIONS LISTED BELOW.

THIS DEVICE IS INTENDED FOR OUTDOOR USE ONLY.

### **WARNING**

USE OF THIS DEVICE IN A MANNER OTHER THAN STATED IN THIS MANUAL, MAY RESULT IN IMPAIRMENT OF THE DESIGNED SAFETY PROTECTION AND THUS AN UNSAFE CONDITION.

<b>SPECIFICATIONS</b>	
<b>MEASUREMENT METHOD</b>	Ultrasonic
<b>FLUID</b>	Propane
<b>TANK TYPES</b>	Steel Tanks Note: Also works with aluminum tanks with alternate mounting. Not intended for use on composite cylinders.
<b>TANK SIZES</b>	Vertical DOT Cylinders of 20 -100 lb (5 - 25 gal) Horizontal tanks up to 11' diameter
<b>Envelope Dimensions</b>	97 x 61 x 17.2 mm (3.8 x 2.4 x 0.68 in)
<b>Mounting location</b>	Tank Bottom
<b>Suitable for these locations</b>	CLASS 1, DIVISION 2, GROUP D CLASS 1, ZONE 2, GROUP IIA
<b>OPERATING TEMPERATURE RANGE</b>	-40° TO 60°C
<b>TEMPERATURE CODE</b>	T6
<b>BATTERY</b>	2 AA (non replaceable)
<b>HUMIDITY RANGE</b>	0 - 100%
<b>MAX ALTITUDE</b>	4000m
<b>AMBIENT CONDITIONS FOR TESTING</b>	23°C, 14.7 PSIA

### **WARNING**

THIS DEVICE IS NOT TO BE REPAIRED OR OTHERWISE MODIFIED.

---

MOPEKA PRODUCTS LLC  
MAILING ADDRESS: 445 FM 1983, COLORADO CITY, TX 79512  
www.mopeka.com  
support@mopeka.com



### **General Instructions & Warnings**

Only install this device as described below. No field assembly is required. The sync process to the app on your smart device, as described below, should occur in an area clearly out of any explosive atmosphere.

Once device is synced to the smart device/app, the device is “in service” and operating normally. Device will then operate continually until battery is exhausted. There is no “Power Off” mode from that point forward. Once in service, the device may then be moved, repositioned, or removed from the tank as needed, without any special instruction or changes to the device.

This equipment is not intended for repair or maintenance,

Any modification of the device may result in an unsafe condition.

The battery in this device is permanent and is not to be changed or tampered with.

Do not use device for any other application, other environment, or in any other manner than as stated in this manual. Any such misuse may result in an unsafe condition.



## OPERATING INSTRUCTIONS

### Smart Device/App Users

1. Go to your app store. Search for Mopeka Tank Check app and install.
2. Launch the app. When it starts it will automatically start a search for Mopeka ✓ sensors.

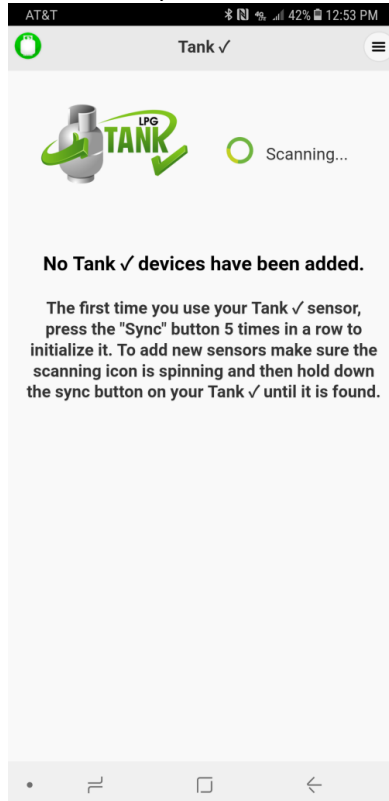

3. Press and hold SYNC button until sensor appears on app. (up to 10 seconds)

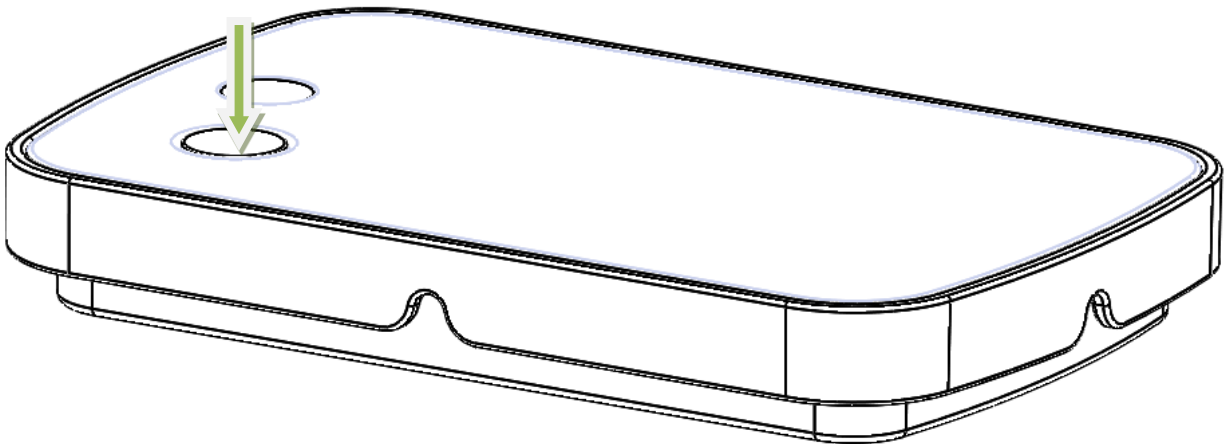



- The sensor will then appear on your app as a new device.

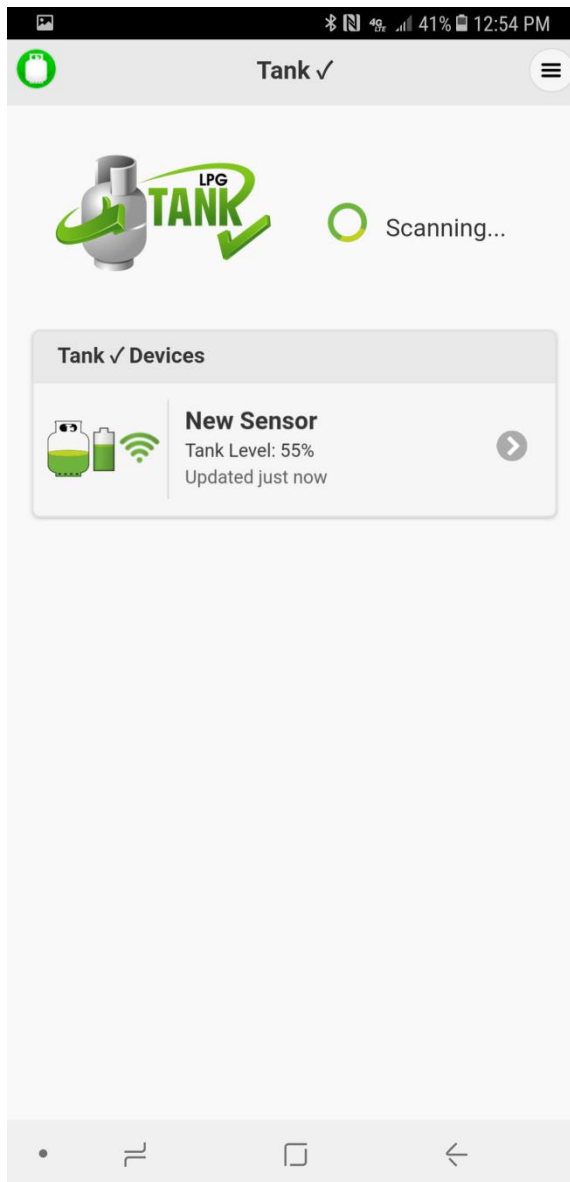

- Sensor is now Sync'd . You may now proceed to installing the sensor on the tank.

### Install Sensor on Tank

6. Clean the bottom of the tank of any debris, excess paint, and rust.
7. Check your tank for adequate bottom clearance to install the sensor. (If using on a small vertical tank like 20, 30, or 40 lbs., or certain 100lb tanks, then you will need to place wood blocks, pavers, or similar under the tank to provide clearance. But in all other cases this should not be an issue.
8. Apply ultrasonic grease to the contact pad between the magnets.

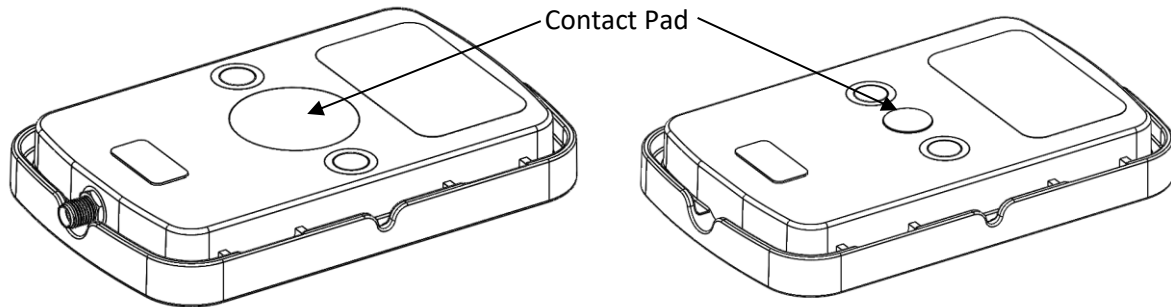

9. **Vertical Tanks:** The sensor mounts to the bottom center of the tank using magnets. The contact pad must make good contact with the tank, with no contaminants in between and must be aligned to the bottom center of the tank. Return the tank to the upright position. Check that the tank is on a level and flat surface or otherwise is level with ground. Even a slight tilt can degrade the quality of the measurement. After a few seconds, up to a few minutes, the propane will settle and the readings will stabilize.
10. **Horizontal Tanks:** If installing on a horizontal tank, place the sensor on center, bottom of tank, with rubber pad and magnets against tank as shown. It is important to place it on the center of tank so that sensor is horizontal, or sensor reading quality can be poor. After a few seconds, up to a few minutes, the the readings will stabilize.

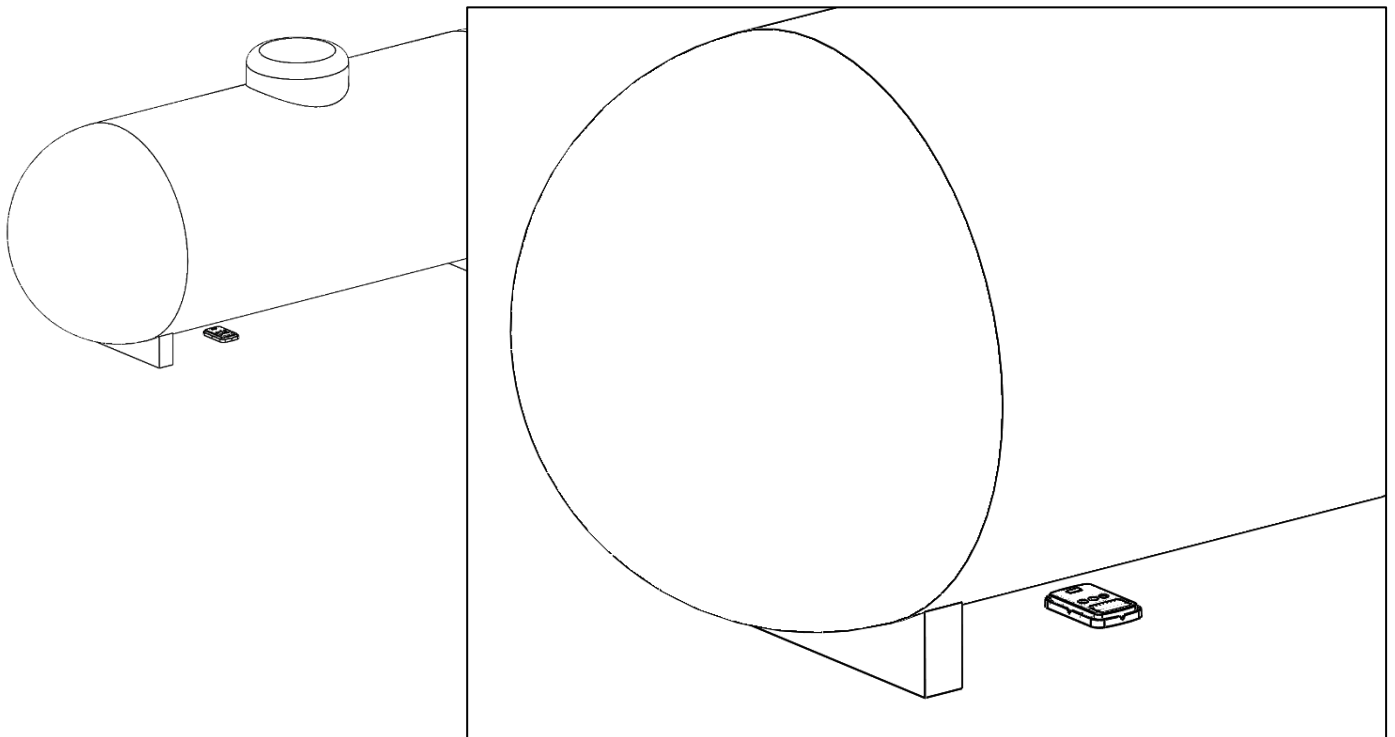

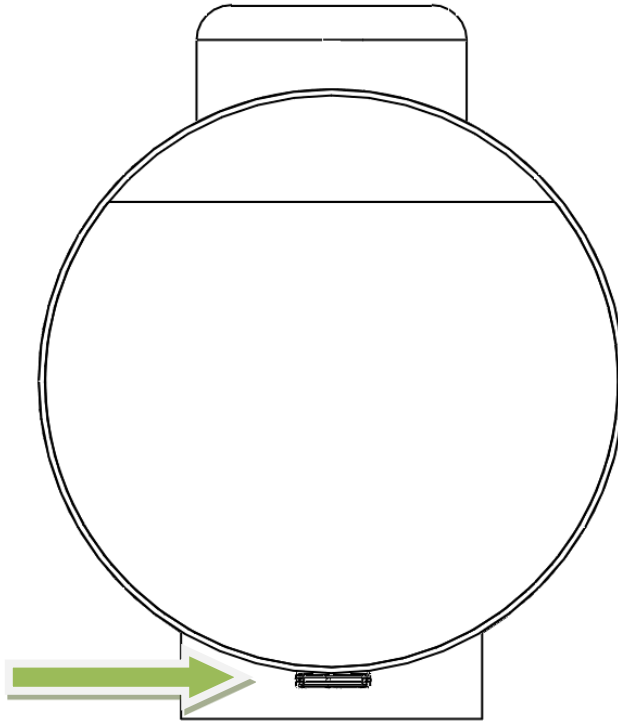



REVISION TABLE

<u>REVISION</u>	<u>DESCRIPTION</u>	<u>DATE</u>
A	RELEASE	2019.09.19

## Federal Communications Commission (FCC) Interference Statement

This equipment has been tested and found to comply with the limits for a Class B digital device, pursuant to Part 15 of the FCC Rules.

These limits are designed to provide reasonable protection against harmful interference in a residential installation. This equipment generate, uses and can radiate radio frequency energy and, if not installed and used in accordance with the instructions, may cause harmful interference to radio communications.

However, there is no guarantee that interference will not occur in a particular installation. If this equipment does cause harmful interference to radio or television reception, which can be determined by turning the equipment off and on, the user is encouraged to try to correct the interference by one of the following measures:

- Reorient or relocate the receiving antenna.
- Increase the separation between the equipment and receiver.
- Connect the equipment into an outlet on a circuit different from that to which the receiver is connected.
- Consult the dealer or an experienced radio/TV technician for help.

This device complies with Part 15 of the FCC Rules. Operation is subject to the following two conditions:

(1) This device may not cause harmful interference, and (2) this device must accept any interference received, including interference that may cause undesired operation.

FCC Caution: Any changes or modifications not expressly approved by the party responsible for compliance could void the user's authority to operate this equipment.

### **RF exposure warning**

This equipment complies with FCC radiation exposure limits set forth for an uncontrolled environment.