



# MEASUREMENT REPORT

## FCC PART 15.247 Bluetooth-LE

---

**FCC ID:** 2AHXJ-M2008  
**APPLICANT:** Mopeka Products, LLC  
**Application Type:** Certification  
**Product:** SENSOR  
**Model No.:** M2008  
**Brand Name:** Vertrax  
**FCC Classification:** Digital Transmission System (DTS)  
**FCC Rule Part(s):** Part15 Subpart C (Section 15.247)  
**Test Procedure(s):** ANSI C63.10-2013, KDB 558074 D01v05r02  
**Test Date:** March 03 ~ August 12, 2020

Reviewed By:



( Kevin Guo )

Approved By:

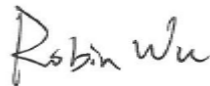

( Robin Wu )



The test results relate only to the samples tested.

This equipment has been shown to be capable of compliance with the applicable technical standards as indicated in the measurement report and was tested in accordance with the measurement procedures specified in ANSI C63.10-2013. Test results reported herein relate only to the item(s) tested.

The test report shall not be reproduced except in full without the written approval of MRT Technology (Suzhou) Co., Ltd.

---

### Revision History

Report No.	Version	Description	Issue Date	Note
2003RSU050-U1	Rev. 01	Initial Report	08-12-2020	Valid

---

## CONTENTS

Description	Page
<b>1. INTRODUCTION .....</b>	<b>6</b>
1.1. Scope .....	6
1.2. MRT Test Location .....	6
<b>2. PRODUCT INFORMATION .....</b>	<b>7</b>
2.1. Feature of Equipment under Test .....	7
2.2. Product Specification Subjective to this Report.....	7
2.3. Working Frequencies for this Report.....	8
2.4. Test Mode .....	8
2.5. Configuration of Test System.....	8
2.6. Test Software .....	9
2.7. Test Environment Condition .....	9
2.8. Duty Cycle .....	9
2.9. Labeling Requirements.....	9
<b>3. ANTENNA REQUIREMENTS.....</b>	<b>10</b>
<b>4. TEST EQUIPMENT CALIBRATION DATE.....</b>	<b>11</b>
<b>5. MEASUREMENT UNCERTAINTY.....</b>	<b>13</b>
<b>6. TEST RESULT .....</b>	<b>14</b>
6.1. Summary .....	14
6.2. 6dB Occupied Bandwidth Measurement .....	15
6.2.1. Test Limit .....	15
6.2.2. Test Procedure used.....	15
6.2.3. Test Setting.....	15
6.2.4. Test Setup.....	15
6.2.5. Test Result.....	16
6.3. Output Power Measurement.....	17
6.3.1. Test Limit .....	17
6.3.2. Test Procedure Used .....	17
6.3.3. Test Setting.....	17
6.3.4. Test Setup.....	17
6.3.5. Test Result.....	18
6.4. Power Spectral Density Measurement.....	19
6.4.1. Test Limit .....	19
6.4.2. Test Procedure Used .....	19
6.4.3. Test Setting.....	19

---

6.4.4.	Test Setup.....	19
6.4.5.	Test Result.....	20
6.5.	Conducted Band Edge and Out-of-Band Emissions.....	21
6.5.1.	Test Limit .....	21
6.5.2.	Test Procedure Used .....	21
6.5.3.	Test Setting.....	21
6.5.4.	Test Setup.....	22
6.5.5.	Test Result.....	23
6.6.	Radiated Spurious Emission Measurement .....	26
6.6.1.	Test Limit .....	26
6.6.2.	Test Procedure Used .....	26
6.6.3.	Test Setting.....	26
6.6.4.	Test Setup.....	28
6.6.5.	Test Result.....	29
6.7.	Radiated Restricted Band Edge Measurement .....	35
6.7.1.	Test Limit .....	35
6.7.2.	Test Procedure Used .....	36
6.7.3.	Test Setting.....	36
6.7.4.	Test Setup.....	37
6.7.5.	Test Result.....	38
6.8.	AC Conducted Emissions Measurement.....	46
6.8.1.	Test Limit .....	46
6.8.2.	Test Setup.....	46
6.8.3.	Test Result.....	46
<b>7.</b>	<b>CONCLUSION.....</b>	<b>47</b>
	<b>Appendix A - Test Setup Photograph .....</b>	<b>48</b>
	<b>Appendix B - EUT Photograph.....</b>	<b>49</b>

## General Information

<b>Applicant:</b>	Mopeka Products, LLC
<b>Applicant Address:</b>	686 Floral Circle New Braunfels, TX 78130 United States
<b>Manufacturer:</b>	Hangzhou Jinmai Technologies Co., Ltd.
<b>Manufacturer Address:</b>	4F, Bldg 1, No.8 Jianghui RD, Binjiang Dist., China, 310052
<b>Test Site:</b>	MRT Technology (Suzhou) Co., Ltd
<b>Test Site Address:</b>	D8 Building, No.2 Tian'edang Rd., Wuzhong Economic Development Zone, Suzhou, China

## Test Facility / Accreditations

Measurements were performed at MRT Laboratory located in Tian'edang Rd., Suzhou, China.

- MRT facility is an FCC accredited testing laboratory (MRT Designation No. CN1166) on the FCC website.
- MRT facility is an ISED recognized testing laboratory (MRT Reg. No. CN0001) on the ISED website.
- MRT facility is a VCCI registered (R-20025, G-20034, C-20020, T-20020) test laboratory with the site description on file at VCCI Council.
- MRT Lab is accredited to ISO 17025 by the A2LA under the A2LA Program (Cert. No. 3628.01) and CNAS under the CNAS Program (Cert. No. L10551) in EMC, Safety, Radio, Telecommunications and SAR testing.

# 1. INTRODUCTION

## 1.1. Scope

Measurement and determination of electromagnetic emissions (EMC) of radio frequency devices including intentional and/or unintentional radiators for compliance with the technical rules and regulations of the Federal Communications Commission and the Innovation, Science and Economic Development Canada and Certification and Engineering Bureau.

## 1.2. MRT Test Location

The map below shows the location of the MRT LABORATORY, its proximity to the Taihu Lake. These measurement tests were conducted at the MRT Technology (Suzhou) Co., Ltd. Facility located at D8 Building, No.2 Tian'edang Rd., Wuzhong Economic Development Zone, Suzhou, China. The measurement facility compliant with the test site requirements specified in ANSI C63.4-2014.



## 2. PRODUCT INFORMATION

### 2.1. Feature of Equipment under Test

Product Name:	SENSOR
Model No.:	M2008
Brand Name:	vertrax
LoRa Specification:	902.5 – 927.5MHz
Bluetooth Version:	Bluetooth-LE
EUT Identification No.:	20200422Sample#02

### 2.2. Product Specification Subjective to this Report

Frequency Range:	2402 ~ 2480MHz
Channel Number:	40
Type of modulation:	GFSK
Data Rate	1Mbps
Antenna Type:	PCB Antenna
Antenna Gain:	3dBi

Note: All messages as above are declared by manufacturer.

### 2.3. Working Frequencies for this Report

Channel	Frequency	Channel	Frequency	Channel	Frequency
00	2402 MHz	01	2404 MHz	02	2406 MHz
03	2408 MHz	04	2410 MHz	05	2412 MHz
06	2414 MHz	07	2416 MHz	08	2418 MHz
09	2420 MHz	10	2422 MHz	11	2424 MHz
12	2426 MHz	13	2428 MHz	14	2430 MHz
15	2432 MHz	16	2434 MHz	17	2436 MHz
18	2438 MHz	19	2440 MHz	20	2442 MHz
21	2444 MHz	22	2446 MHz	23	2448 MHz
24	2450 MHz	25	2452 MHz	26	2454 MHz
27	2456 MHz	28	2458 MHz	29	2460 MHz
30	2462 MHz	31	2464 MHz	32	2466 MHz
33	2468 MHz	34	2470 MHz	35	2472 MHz
36	2474 MHz	37	2476 MHz	38	2478 MHz
39	2480 MHz	--	--	--	--

### 2.4. Test Mode

Test Mode	Transmit by Bluetooth-LE (1Mbps)
-----------	----------------------------------

### 2.5. Configuration of Test System

The measurement procedures and appropriate EUT setup described in the American National Standard of Procedures for Compliance Testing of Unlicensed Wireless Devices (ANSI C63.10-2013) was used in the measurement.

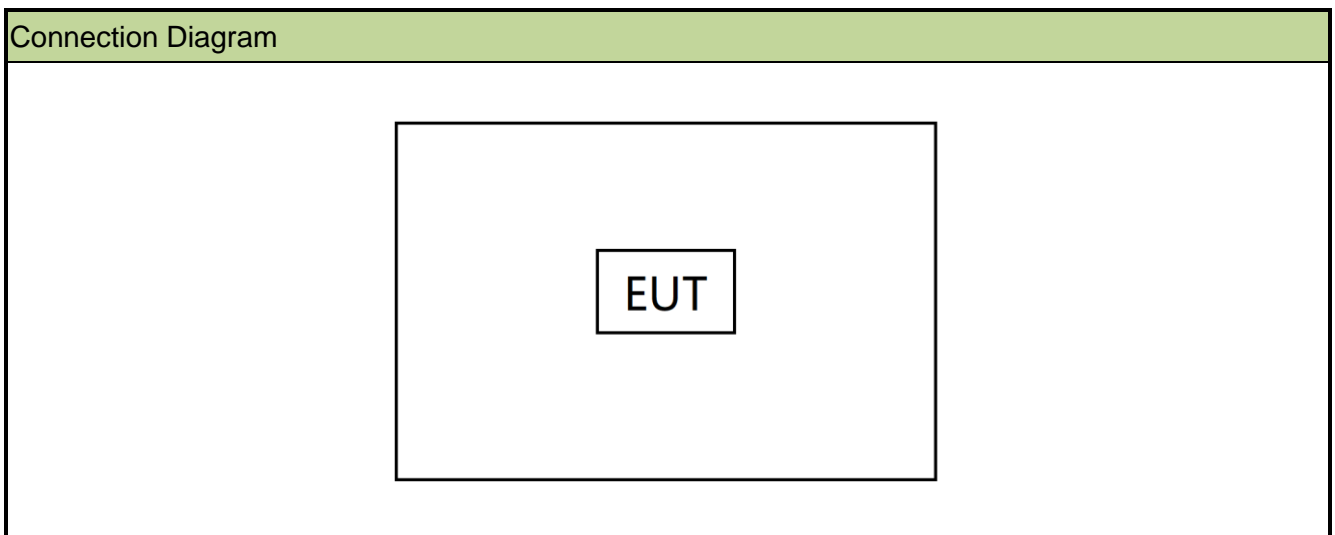



### 2.6. Test Software

The sample is configured by the manufacturer into engineering mode, by pressing the button, we can select a different channel and continuously transmit signals on this channel.

### 2.7. Test Environment Condition

Ambient Temperature	15°C~35°C
Relative Humidity	20%RH ~75%RH

### 2.8. Duty Cycle

The maximum achievable duty cycles were determined based on measurements performed on a spectrum analyzer in zero-span mode with RBW = 8MHz, VBW = 50MHz. The RBW and VBW were both greater than 50/T, where T is the minimum transmission duration, and the number of sweep points across T was greater than 100. The duty cycles are as follows:

Test Mode	Duty Cycle
BLE	100%

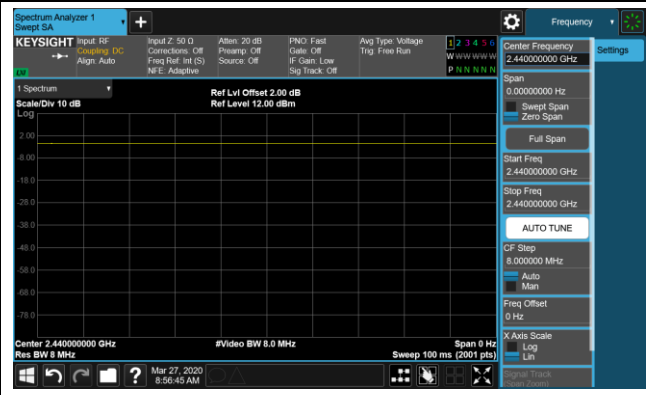
Duty Cycle	
BLE	--
	--

### 2.9. Labeling Requirements

Per 2.1074 & 15.19; Docket 95-19

The label shall be permanently affixed at a conspicuous location on the device; instruction manual or pamphlet supplied to the user and be readily visible to the purchaser at the time of purchase. However, when the device is so small wherein placement of the label with specified statement is not practical, only the FCC ID must be displayed on the device per Section 15.19(a)(5). Please see attachment for FCC ID label and label location.

### 3. ANTENNA REQUIREMENTS

**Excerpt from §15.203 of the FCC Rules/Regulations:**

“An intentional radiator antenna shall be designed to ensure that no antenna other than that furnished by the responsible party can be used with the device. The use of a permanently attached antenna or of an antenna that uses a unique coupling to the intentional radiator shall be considered sufficient to comply with the provisions of this section.”

- The antenna of the unit is **permanently attached**.
- There are no provisions for connection to an external antenna.

**Conclusion:**

The unit complies with the requirement of §15.203.

#### 4. TEST EQUIPMENT CALIBRATION DATE

##### Conducted Emission - SR2

Instrument	Manufacturer	Type No.	Asset No.	Cali. Interval	Cali. Due Date
EMI Test Receiver	R&S	ESR3	MRTSUE06185	1 year	2021/01/18
Two-Line V-Network	R&S	ENV216	MRTSUE06002	1 year	2021/06/11
Thermal Hygrometer	testo	608-H1	MRTSUE06404	1 year	2021/07/23
Shielding Room	MIX-BEP	Chamber-SR2	MRTSUE06215	N/A	N/A

##### Radiated Emission - AC1

Instrument	Manufacturer	Type No.	Asset No.	Cali. Interval	Cali. Due Date
EMI Test Receiver	R&S	ESR7	MRTSUE06001	1 year	2021/01/18
PXA Signal Analyzer	Keysight	N9030B	MRTSUE06395	1 year	2020/09/03
Loop Antenna	Schwarzbeck	FMZB 1519	MRTSUE06025	1 year	2020/11/13
Bilog Period Antenna	Schwarzbeck	VULB 9168	MRTSUE06172	1 year	2021/04/03
Horn Antenna	Schwarzbeck	BBHA 9120D	MRTSUE06023	1 year	2020/10/13
Horn Antenna	Schwarzbeck	BBHA9170	MRTSUE06597	1 year	2020/12/17
Microwave System Amplifier	Agilent	83017A	MRTSUE06076	1 year	2020/11/15
Preamplifier	Schwarzbeck	BBV 9721	MRTSUE06121	1 year	2021/06/11
Thermal Hygrometer	testo	608-H1	MRTSUE06403	1 year	2021/07/26
Anechoic Chamber	TDK	Chamber-AC1	MRTSUE06212	1 year	2021/04/30

##### Radiated Emission - AC2

Instrument	Manufacturer	Type No.	Asset No.	Cali. Interval	Cali. Due Date
MXE EMI Receiver	Keysight	N9038A	MRTSUE06125	1 year	2021/07/02
Loop Antenna	Schwarzbeck	FMZB 1519	MRTSUE06025	1 year	2020/11/13
Bilog Period Antenna	Schwarzbeck	VULB 9162	MRTSUE06022	1 year	2020/10/13
Broad-Band Horn Antenna	Schwarzbeck	BBHA 9120D	MRTSUE06171	1 year	2020/10/27
Horn Antenna	Schwarzbeck	BBHA9170	MRTSUE06597	1 year	2020/12/17
Broadband Coaxial Preamplifier	Schwarzbeck	BBV 9718	MRTSUE06176	1 year	2020/11/15
Preamplifier	Schwarzbeck	BBV 9721	MRTSUE06121	1 year	2021/06/11
Thermal Hygrometer	Minggao	ETH529	MRTSUE06170	1 year	2020/12/15
Anechoic Chamber	RIKEN	Chamber-AC2	MRTSUE06213	1 year	2021/04/30

## Conducted Test Equipment - TR3

Instrument	Manufacturer	Type No.	Asset No.	Cali. Interval	Cali. Due Date
EXA Signal Analyzer	Agilent	N9020A	MRTSUE06106	1 year	2021/04/14
EXA Signal Analyzer	Keysight	N9010B	MRTSUE06607	1 year	2021/01/08
Signal Analyzer	R&S	FSV40	MRTSUE06218	1 year	2021/04/14
Power Meter	Agilent	U2021XA	MRTSUE06030	1 year	2020/11/18
USB wideband power sensor	Keysight	U2021XA	MRTSUE06446	1 year	2021/06/11
USB wideband power sensor	Keysight	U2021XA	MRTSUE06447	1 year	2021/06/11
Bluetooth Test Set	Anritsu	MT8852B-042	MRTSUE06389	1 year	2021/06/11
Audio Analyzer	Agilent	U8903B	MRTSUE06143	1 year	2021/06/11
Modulation Analyzer	HP	HP8901A	MRTSUE06098	1 year	2020/10/10
Wideband Radio Communication Tester	R&S	CMW 500	MRTSUE06243	1 year	2020/11/07
DC Power Supply	GWINSTEK	DPS-3303C	MRTSUE06064	N/A	N/A
Temperature & Humidity Chamber	BAOYT	BYH-150CL	MRTSUE06051	1 year	2020/11/07
Thermal Hygrometer	testo	608-H1	MRTSUE06401	1 year	2021/07/23

Software	Version	Function
EMI Software	V3	EMI Test Software

## 5. MEASUREMENT UNCERTAINTY

Where relevant, the following test uncertainty levels have been estimated for tests performed on the EUT as specified in CISPR 16-4-2. This uncertainty represents an expanded uncertainty expressed at approximately the 95% confidence level using a coverage factor of  $k = 2$ .

<b>Conducted Emission Measurement</b>
Measurement Uncertainty for a Level of Confidence of 95% ( $U=2Uc(y)$ ): 9kHz~150kHz: 3.74dB 150kHz~30MHz: 3.44dB
<b>Radiated Disturbance</b>
Measurement Uncertainty for a Level of Confidence of 95% ( $U=2Uc(y)$ ): Horizontal: 9KHz~300MHz: 5.04dB 300MHz~1GHz: 4.95dB 1GHz~6GHz: 6.40dB Vertical: 9KHz~300MHz: 5.24dB 300MHz~1GHz: 6.03dB 1GHz~40GHz: 6.40dB
<b>Spurious Emissions, Conducted</b>
Measuring Uncertainty for a Level of Confidence of 95% ( $U=2Uc(y)$ ): 0.78dB
<b>Output Power</b>
Measuring Uncertainty for a Level of Confidence of 95% ( $U=2Uc(y)$ ): 1.13dB
<b>Power Spectrum Density</b>
Measuring Uncertainty for a Level of Confidence of 95% ( $U=2Uc(y)$ ): 1.15dB
<b>Occupied Bandwidth</b>
Measuring Uncertainty for a Level of Confidence of 95% ( $U=2Uc(y)$ ): 0.28%

## 6. TEST RESULT

### 6.1. Summary

FCC Part Section(s)	Test Description	Test Limit	Test Condition	Test Result	Reference
15.247(a)(2)	6dB Bandwidth	$\geq 500\text{kHz}$	Conducted	Pass	Section 6.2
15.247(b)(3), (4)	Output Power	$\leq 30\text{dBm}$		Pass	Section 6.3
15.247(e)	Power Spectral Density	$\leq 8\text{dBm}/3\text{kHz}$		Pass	Section 6.4
15.247(d)	Band Edge / Out-of-Band Emissions	20dBc (Peak)		Pass	Section 6.5
15.205 15.209	General Field Strength Limits (Restricted Bands and Radiated Emission Limits)	Emissions in restricted bands must meet the radiated limits detailed in 15.209	Radiated	Pass	Section 6.6 & 6.7
15.207	AC Conducted Emissions 150kHz - 30MHz	< FCC 15.207 limits	Line Conducted	N/A	Section 6.8

#### Notes:

- 1) The analyzer plots shown in this section were all taken with a correction table loaded into the analyzer. The correction table was used to account for the losses of the cables and attenuators used as part of the system to connect the EUT to the analyzer at all frequencies of interest.
- 2) For radiated emission test, every axis (X, Y, Z) was also verified. The test results shown in the following sections represent the worst-case emissions.
- 3) "N/A" means that the test item is not applicable, and the details information refer to relevant section.

## 6.2. 6dB Occupied Bandwidth Measurement

### 6.2.1. Test Limit

The minimum 6dB bandwidth shall be at least 500 kHz.

### 6.2.2. Test Procedure used

ANSI C63.10-2013 - Section 11.8

### 6.2.3. Test Setting

1. The Spectrum's automatic bandwidth measurement capability was used to perform the 6dB bandwidth measurement. The "X" dB bandwidth parameter was set to  $X = 6$ . The bandwidth measurement was not influenced by any intermediate power nulls in the fundamental emission.
2. Set RBW = 100 kHz
3. VBW  $\geq 3 \times$  RBW
4. Detector = Peak
5. Trace mode = Max hold
6. Sweep = Auto couple
7. Allow the trace was allowed to stabilize

### 6.2.4. Test Setup

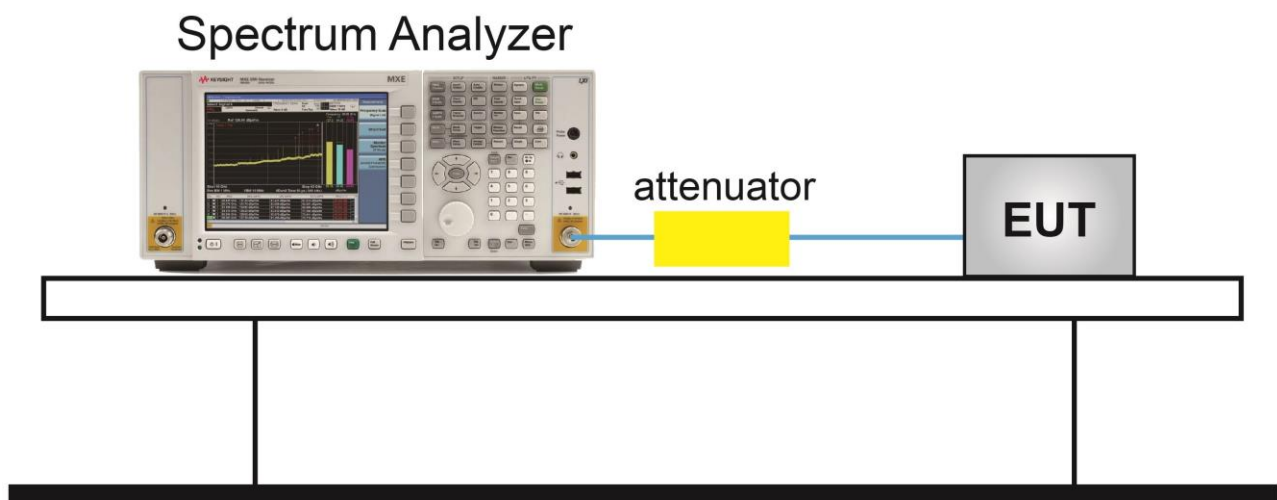

### 6.2.5. Test Result

Product	SENSOR	Test Engineer	Dandy Li
Test Site	TR3	Test Date	2020/03/27

Test Mode	Data Rate (Mbps)	Channel No.	Frequency (MHz)	6dB Bandwidth (MHz)	Limit (MHz)	Result
Bluetooth-LE	1	00	2402	0.744	≥ 0.5	Pass
Bluetooth-LE	1	19	2440	0.751	≥ 0.5	Pass
Bluetooth-LE	1	39	2480	0.745	≥ 0.5	Pass

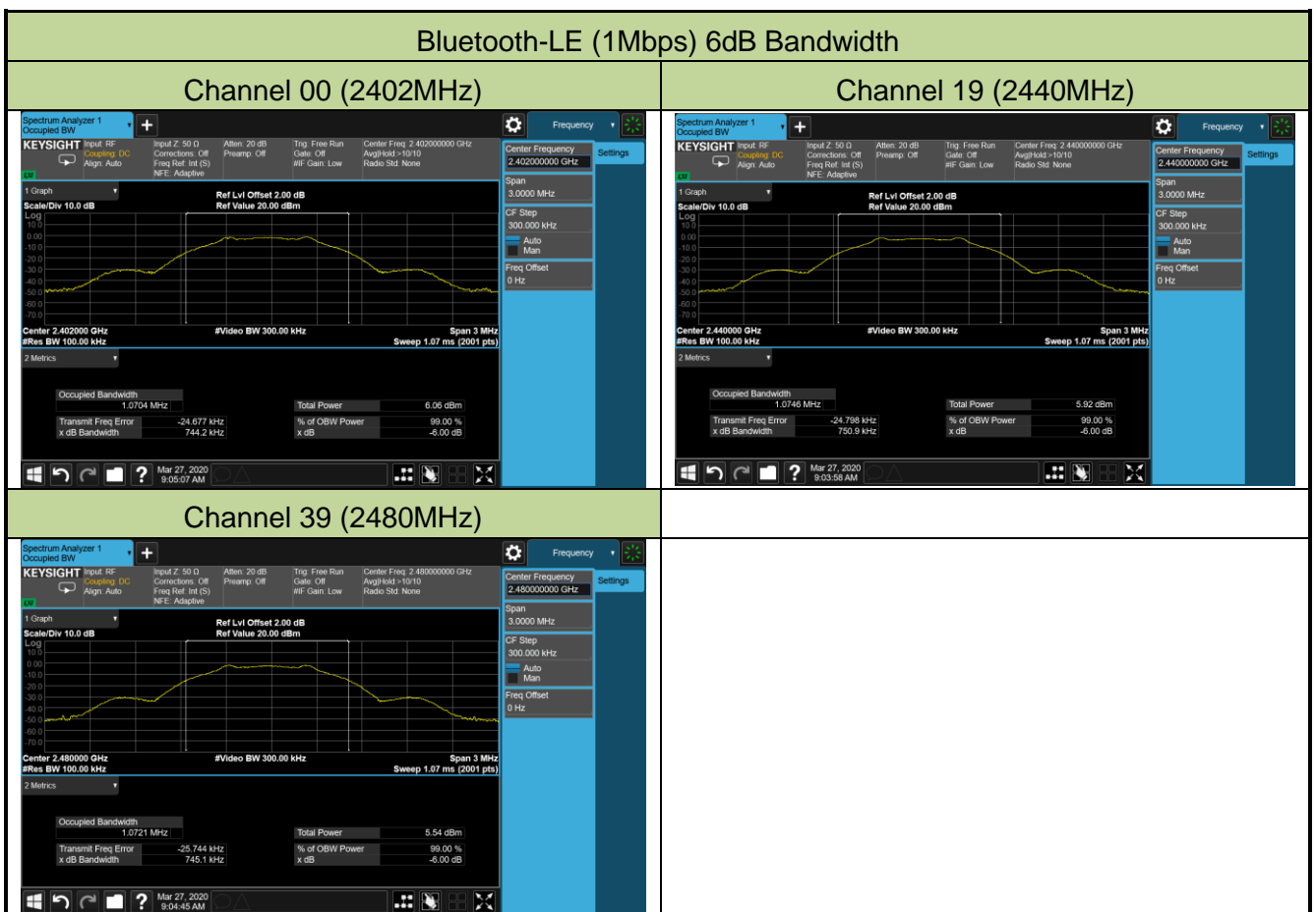



### 6.3. Output Power Measurement

#### 6.3.1. Test Limit

The maximum out power shall be less 1 Watt (30dBm).

The conducted output power limit specified in paragraph FCC Part 15.247(b) of this section is based on the use of antennas with directional gains that do not exceed 6 dBi. If transmitting antennas of directional gain greater than 6 dBi are used, the conducted output power from the intentional radiator shall be reduced below the stated values in paragraphs FCC Part 15.247(b)(3) of this section, as appropriate, by the amount in dB that the directional gain of the antenna exceeds 6 dBi.

#### 6.3.2. Test Procedure Used

ANSI C63.10 - Section 11.9.1.3

#### 6.3.3. Test Setting

##### Method PKPM1 (Peak Power Measurement)

Peak power measurements were performed only when the EUT was transmitting at its maximum power control level using a broadband power meter with a pulse sensor. The pulse sensor employs a VBW = 50MHz so this method was only used for signals whose DTS bandwidth was less than or equal to 50MHz.

#### 6.3.4. Test Setup

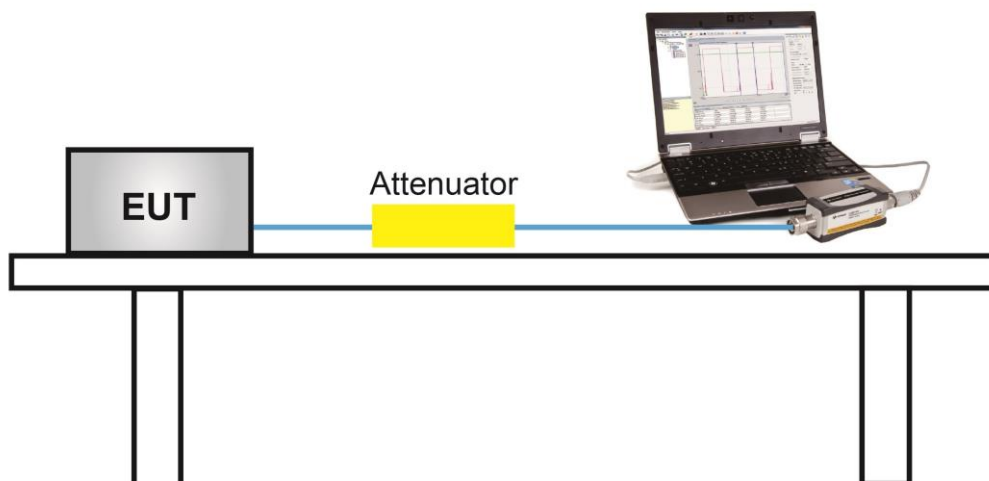

**6.3.5. Test Result**

Product	SENSOR	Temperature	25°C
Test Engineer	Yuri Li	Relative Humidity	52%
Test Site	TR3	Test Date	2020/03/27

Test Mode	Data Rate (Mbps)	Channel No.	Frequency (MHz)	Peak Power (dBm)	Limit (dBm)	Result
Bluetooth-LE	1	00	2402	-0.53	≤ 30.00	Pass
Bluetooth-LE	1	19	2440	-0.99	≤ 30.00	Pass
Bluetooth-LE	1	39	2480	-1.22	≤ 30.00	Pass

## 6.4. Power Spectral Density Measurement

### 6.4.1. Test Limit

The maximum permissible power spectral density is 8dBm in any 3 kHz band.

The same method of determining the conducted output power shall be used to determine the power spectral density.

### 6.4.2. Test Procedure Used

ANSI C63.10 - Section 11.10.2

### 6.4.3. Test Setting

1. Analyzer was set to the center frequency of the DTS channel under investigation
2. Span = 1.5 times the DTS channel bandwidth
3. RBW = 3kHz
4. VBW = 10kHz
5. Detector = Peak
6. Sweep time = Auto couple
7. Trace mode = Max hold
8. Trace was allowed to stabilize

### 6.4.4. Test Setup

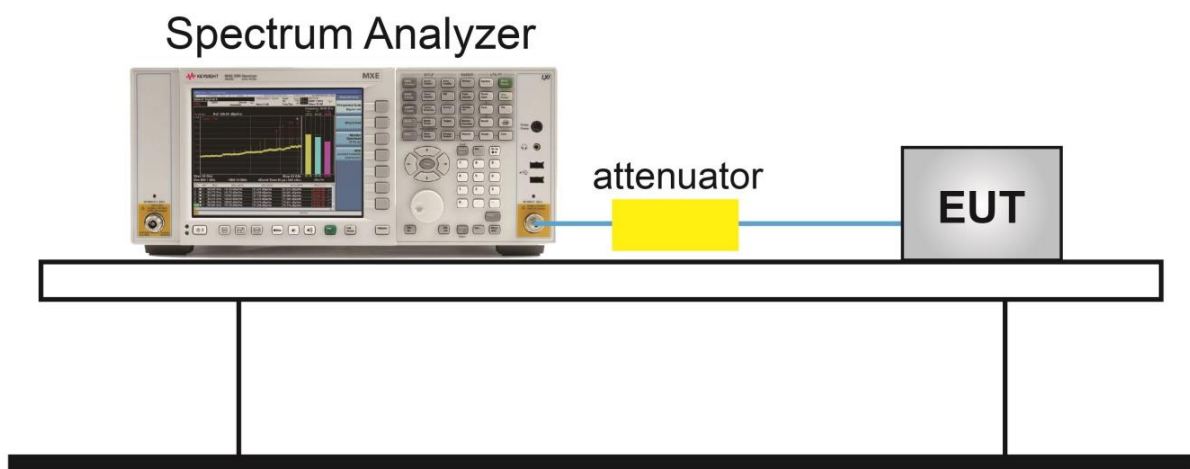

### 6.4.5. Test Result

Product	SENSOR	Temperature	25°C
Test Engineer	Eric Xu	Relative Humidity	52%
Test Site	TR3	Test Date	2020/03/27

Test Mode	Data Rate (Mbps)	Channel No.	Frequency (MHz)	PSD Result (dBm / 3kHz)	Limit (dBm / 3kHz)	Result
Bluetooth-LE	1	00	2402	-13.66	≤ 8.00	Pass
Bluetooth-LE	1	19	2440	-14.05	≤ 8.00	Pass
Bluetooth-LE	1	39	2480	-14.26	≤ 8.00	Pass

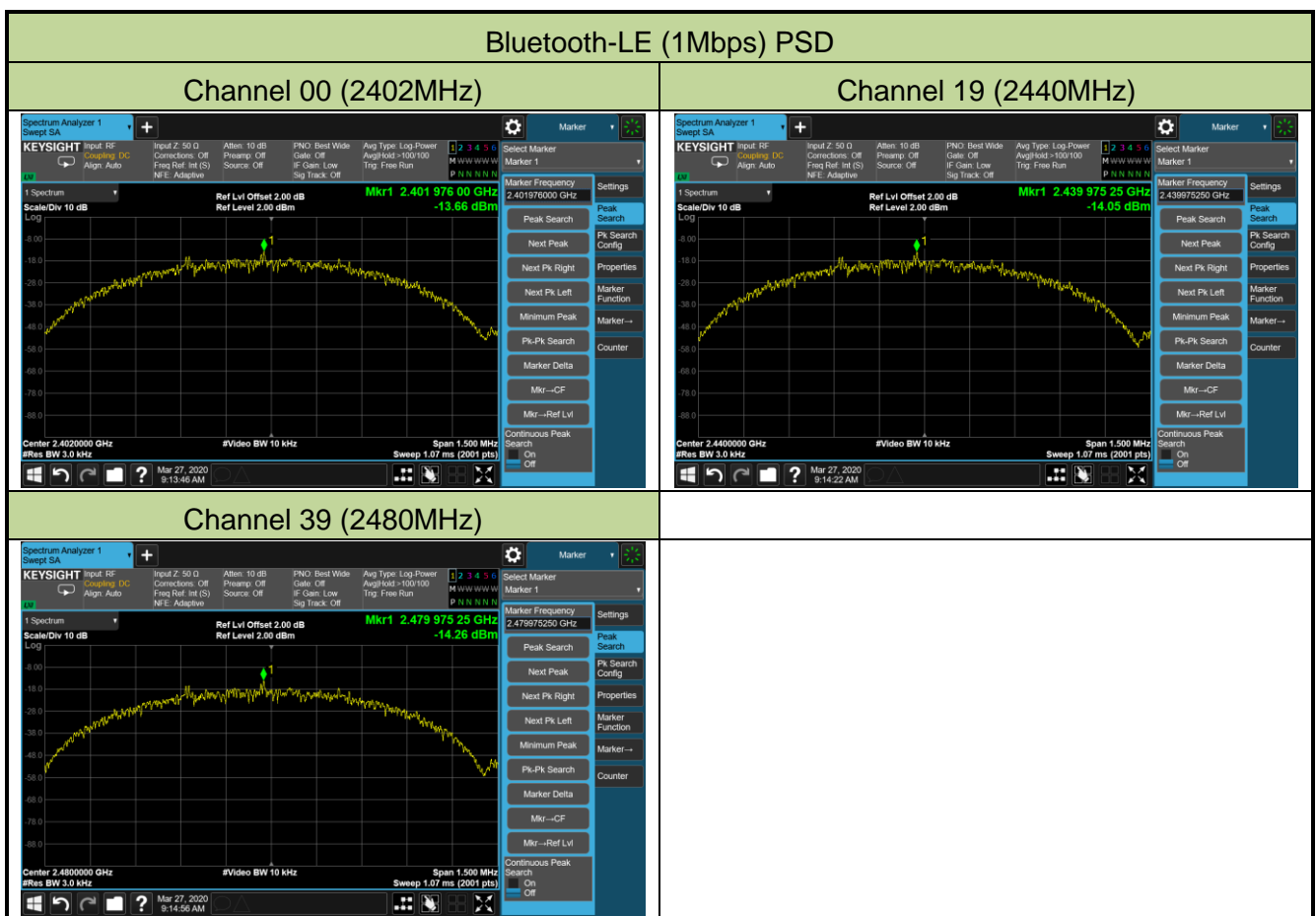

## **6.5. Conducted Band Edge and Out-of-Band Emissions**

### **6.5.1. Test Limit**

The limit for out-of-band spurious emissions at the band edge is 20 dB below the fundamental emission level, as determined from the in-band power measurement of the DTS channel performed in a 100 kHz bandwidth per the PSD procedure.

### **6.5.2. Test Procedure Used**

ANSI C63.10 - Section 11.11

### **6.5.3. Test Setting**

#### **Reference level measurement**

1. Set instrument center frequency to DTS channel center frequency
2. Set the span to  $\geq 1.5$  times the DTS bandwidth
3. Set the RBW = 100 KHz
4. Set the VBW  $\geq 3 \times$  RBW
5. Detector = Peak
6. Sweep time = Auto couple
7. Trace mode = Max hold
8. Allow trace to fully stabilize

#### **Emission level measurement**

1. Set the center frequency and span to encompass frequency range to be measured
2. RBW = 100KHz
3. VBW = 300KHz
4. Detector = Peak
5. Trace mode = Max hold
6. Sweep time = Auto couple
7. The trace was allowed to stabilize

### 6.5.4. Test Setup

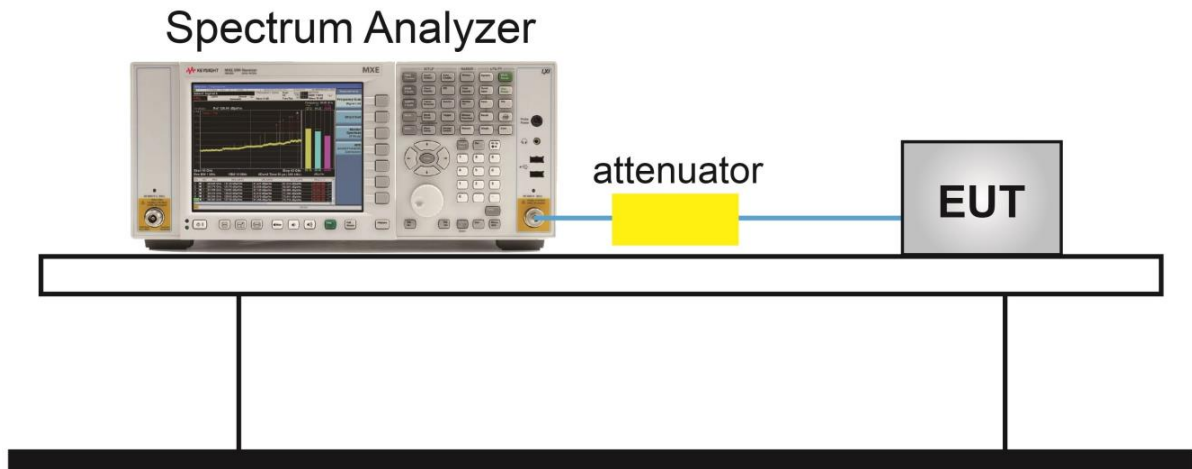

**6.5.5. Test Result**

Product	SENSOR	Temperature	23°C
Test Engineer	Eric Xu	Relative Humidity	54%
Test Site	TR3	Test Date	2020/08/12

Test Mode	Data Rate (Mbps)	Channel No.	Frequency (MHz)	Limit	Result
Bluetooth-LE	1	00	2402	20dBc	Pass
Bluetooth-LE	1	19	2440	20dBc	Pass
Bluetooth-LE	1	39	2480	20dBc	Pass

### Bluetooth-LE (1Mbps) Out-of-Band Emissions

#### Channel 00 (2402MHz)

##### 100kHz PSD reference Level



##### Low Band Edge

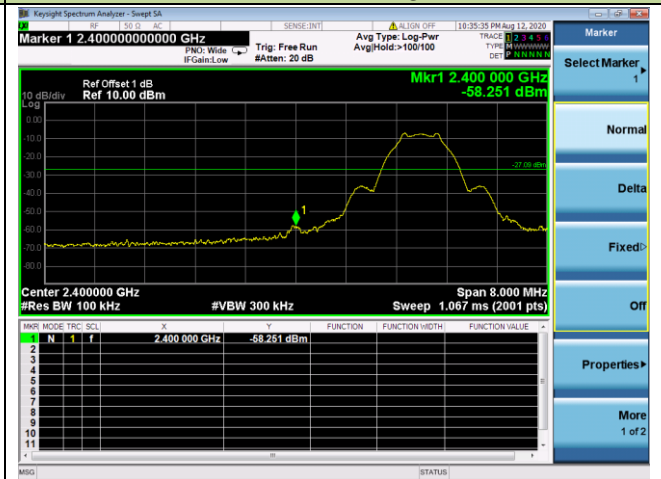

##### Spurious Emission 30MHz ~ 25GHz

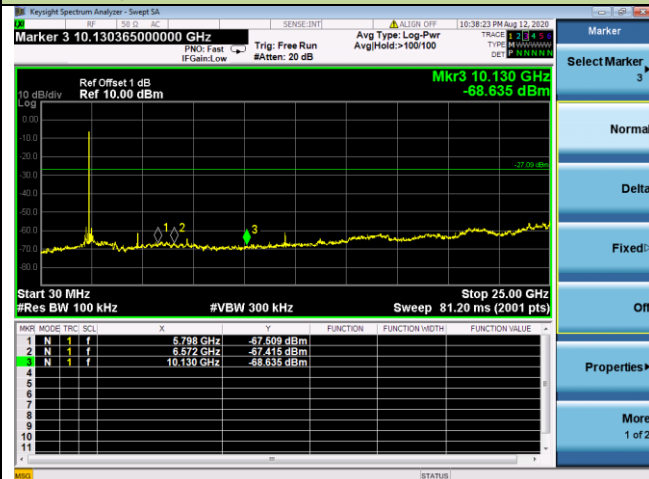

#### Channel 19 (2440MHz)

##### 100kHz PSD reference Level

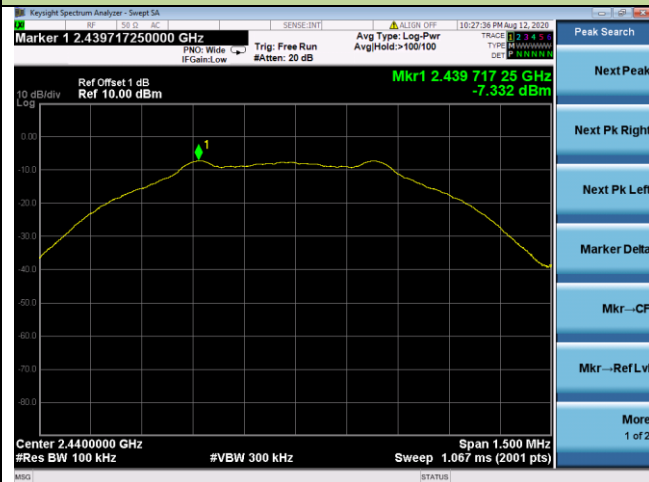

##### Spurious Emission 30MHz ~ 25GHz

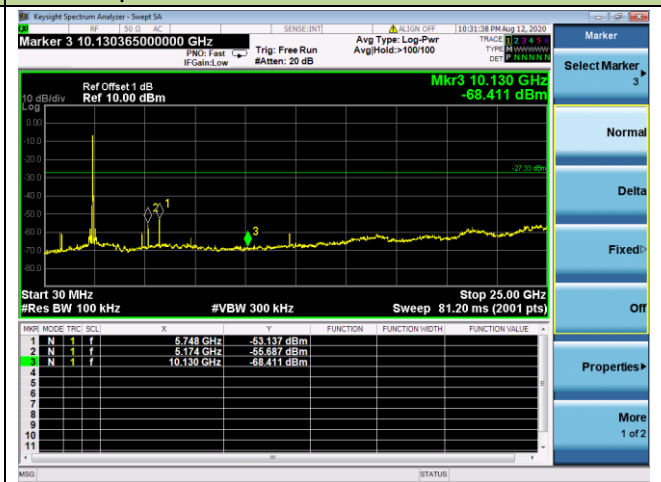



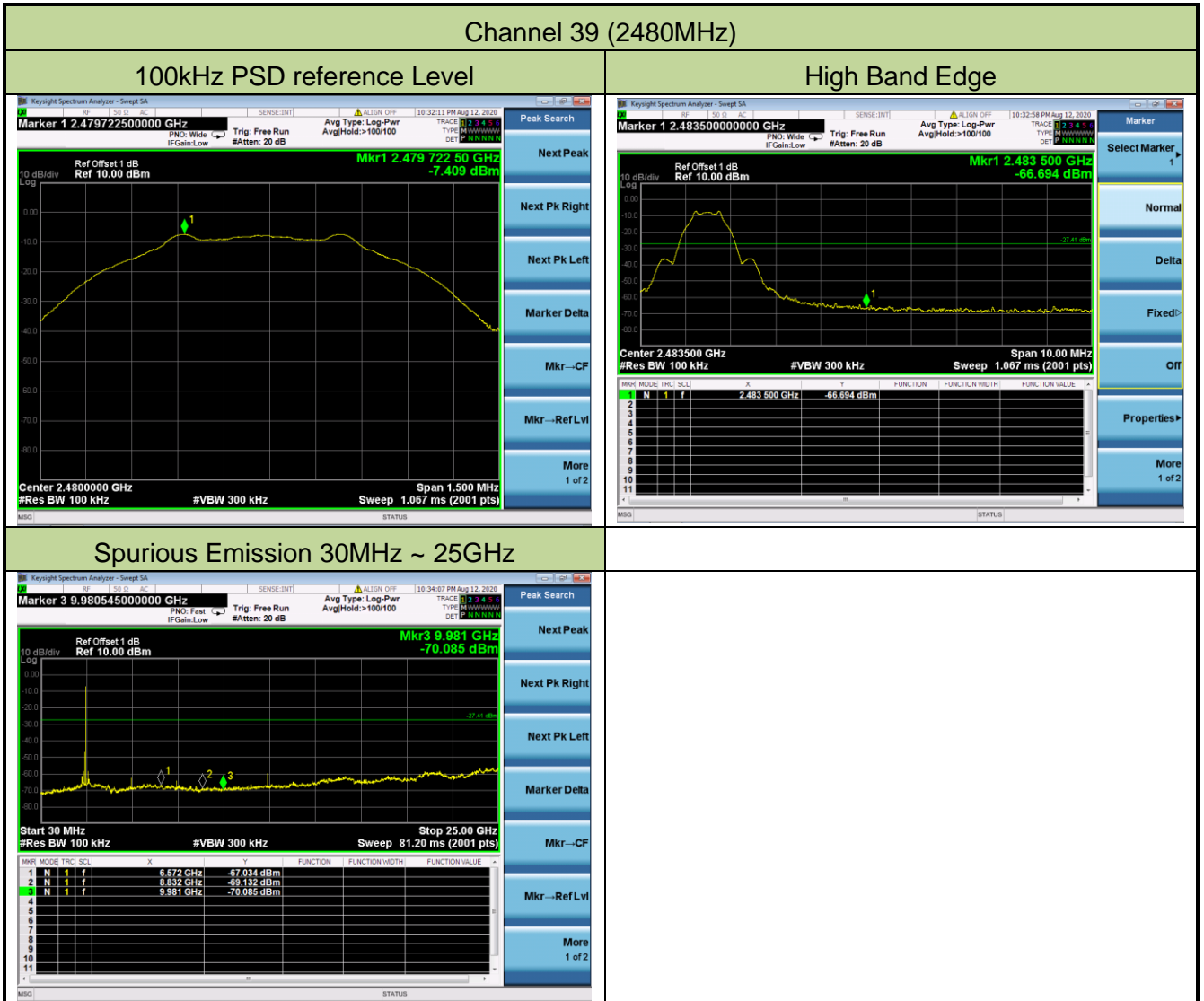

## 6.6. Radiated Spurious Emission Measurement

### 6.6.1. Test Limit

All out of band emissions appearing in a restricted band as specified in Section 15.205 of the Title 47 CFR must not exceed the limits shown in Table per Section 15.209.

FCC Part 15.209 Limits		
Frequency (MHz)	Field Strength ( $\mu\text{V}/\text{m}$ )	Measured Distance (m)
0.009 - 0.490	2400/F (kHz)	300
0.490 - 1.705	24000/F (kHz)	30
1.705 - 30	30	30
30 - 88	100	3
88 - 216	150	3
216 - 960	200	3
Above 960	500	3

### 6.6.2. Test Procedure Used

ANSI C63.10 - Section 6.3 (General Requirements)

ANSI C63.10 - Section 6.4 (Standard test method below 30MHz)

ANSI C63.10 - Section 6.5 (Standard test method above 30MHz to 1GHz)

ANSI C63.10 - Section 6.6 (Standard test method above 1GHz)

### 6.6.3. Test Setting

**Table 1 - RBW as a function of frequency**

Frequency	RBW
9 ~ 150 kHz	200 ~ 300 Hz
0.15 ~ 30 MHz	9 ~ 10 kHz
30 ~ 1000 MHz	100 ~ 120 kHz
> 1000 MHz	1 MHz

**Quasi-Peak Measurements below 1GHz**

1. Analyzer center frequency was set to the frequency of the radiated spurious emission of interest
2. Span was set greater than 1MHz
3. RBW = as specified in Table 1
4. Detector = CISPR quasi-peak
5. Sweep time = auto couple
6. Trace was allowed to stabilize

**Peak Measurements above 1GHz**

1. Analyzer center frequency was set to the frequency of the radiated spurious emission of interest
2. RBW = 1MHz
3. VBW = 3MHz
4. Detector = peak
5. Sweep time = auto couple
6. Trace mode = max hold
7. Trace was allowed to stabilize

**Average Measurements above 1GHz (Method VB)**

1. Analyzer center frequency was set to the frequency of the radiated spurious emission of interest
2. RBW = 1MHz
3. VBW; If the EUT is configured to transmit with duty cycle  $\geq 98\%$ , set VBW = 10Hz  
If the EUT duty cycle is  $< 98\%$ , set VBW  $\geq 1/T$ . T is the minimum transmission duration
4. Detector = Peak
5. Sweep time = auto
6. Trace mode = max hold
7. Trace was allowed to stabilize

### 6.6.4. Test Setup

#### Below 1GHz Test Setup:

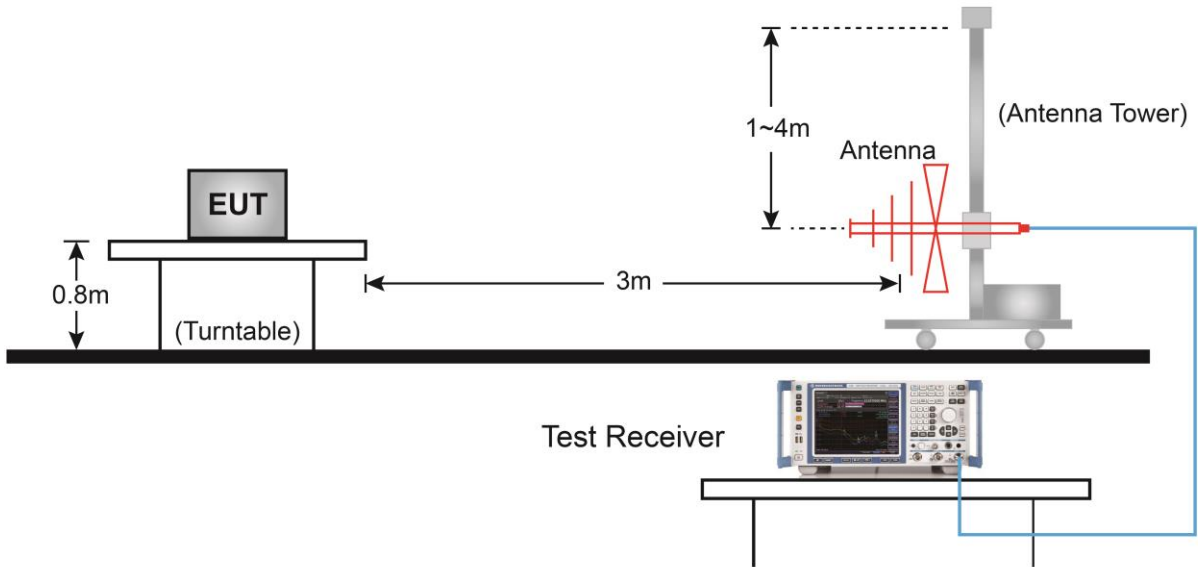

#### Above 1GHz Test Setup:

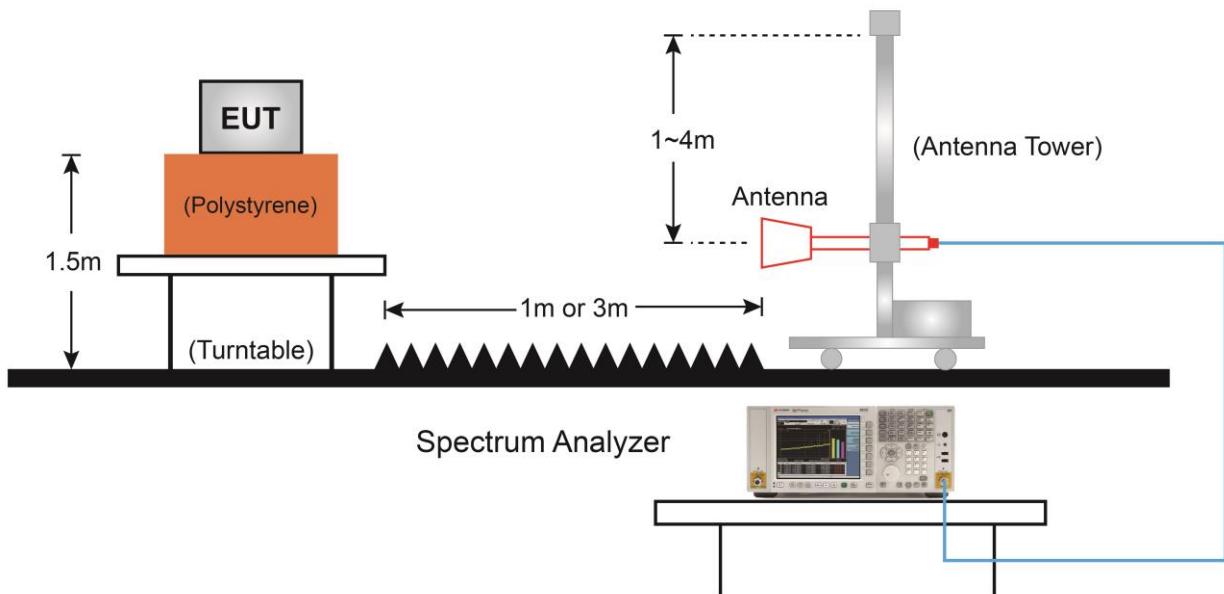

### 6.6.5. Test Result

Product	SENSOR	Test Engineer	Jason Gao
Test Site	AC1	Test Date	2020/03/26
Test Mode	Bluetooth-LE	Test Channel:	00
Remark	1. Average measurement was not performed if peak level lower than average limit. 2. Other frequency was 20dB below limit line within 1-18GHz, there is not show in the report.		

Mark	Frequency (MHz)	Reading Level (dBμV)	Factor (dB)	Measure Level (dBμV/m)	Limit (dBμV/m)	Margin (dB)	Detector	Polarization
*	3091.0	39.6	1.3	40.9	80.3	-39.4	Peak	Horizontal
*	7205.0	42.3	11.5	53.8	80.3	-26.5	Peak	Horizontal
	7638.5	35.2	11.4	46.6	74.0	-27.4	Peak	Horizontal
	8395.0	35.2	12.4	47.6	74.0	-26.4	Peak	Horizontal
*	6321.0	38.5	8.5	47.0	80.3	-33.3	Peak	Vertical
*	7205.0	39.1	11.5	50.6	80.3	-29.7	Peak	Vertical
	7502.5	35.1	11.9	47.0	74.0	-27.0	Peak	Vertical
	8148.5	35.5	12.5	48.0	74.0	-26.0	Peak	Vertical

Note 1: "\*" means test frequency did not fall into restricted band.

Note 2: Measure Level (dBμV/m) = Reading Level (dBμV) + Factor (dB)

Factor (dB) = Cable Loss (dB) + Antenna Factor (dB/m) - Pre\_Amplifier Gain (dB)

Product	SENSOR	Test Engineer	Jason Gao
Test Site	AC1	Test Date	2020/03/26
Test Mode	Bluetooth-LE	Test Channel:	19
Remark	1. Average measurement was not performed if peak level lower than average limit. 2. Other frequency was 20dB below limit line within 1-18GHz, there is not show in the report.		

Mark	Frequency (MHz)	Reading Level (dBμV)	Factor (dB)	Measure Level (dBμV/m)	Limit (dBμV/m)	Margin (dB)	Detector	Polarization
*	5301.0	35.3	6.6	41.9	79.9	-38.0	Peak	Horizontal
*	5998.0	35.7	7.9	43.6	79.9	-36.3	Peak	Horizontal
	7315.5	41.9	11.6	53.5	74.0	-20.5	Peak	Horizontal
	8395.0	36.1	12.4	48.5	74.0	-25.5	Peak	Horizontal
*	7060.5	35.8	11.0	46.8	79.9	-33.1	Peak	Vertical
*	7970.0	36.8	12.4	49.2	79.9	-30.7	Peak	Vertical
	8157.0	36.4	12.5	48.9	74.0	-25.1	Peak	Vertical
	9168.5	34.7	15.3	50.0	74.0	-24.0	Peak	Vertical

Note 1: "\*" means test frequency did not fall into restricted band.

Note 2: Measure Level (dBμV/m) = Reading Level (dBμV) + Factor (dB)

Factor (dB) = Cable Loss (dB) + Antenna Factor (dB/m) - Pre\_Amplifier Gain (dB)

Product	SENSOR	Test Engineer	Jason Gao
Test Site	AC1	Test Date	2020/03/26
Test Mode	Bluetooth-LE	Test Channel:	39
Remark	1. Average measurement was not performed if peak level lower than average limit. 2. Other frequency was 20dB below limit line within 1-18GHz, there is not show in the report.		

Mark	Frequency (MHz)	Reading Level (dBμV)	Factor (dB)	Measure Level (dBμV/m)	Limit (dBμV/m)	Margin (dB)	Detector	Polarization
*	5301.0	37.0	6.6	43.6	79.7	-36.1	Peak	Horizontal
*	5989.5	36.7	7.8	44.5	79.7	-35.2	Peak	Horizontal
	7443.0	39.0	12.1	51.1	74.0	-22.9	Peak	Horizontal
	8199.5	35.7	12.4	48.1	74.0	-25.9	Peak	Horizontal
*	5233.0	35.4	6.8	42.2	79.7	-37.5	Peak	Vertical
*	6423.0	36.1	9.1	45.2	79.7	-34.5	Peak	Vertical
	7443.0	36.6	12.1	48.7	74.0	-25.3	Peak	Vertical
	8225.0	36.5	12.4	48.9	74.0	-25.1	Peak	Vertical

Note 1: "\*" means test frequency did not fall into restricted band.

Note 2: Measure Level (dBμV/m) = Reading Level (dBμV) + Factor (dB)

Factor (dB) = Cable Loss (dB) + Antenna Factor (dB/m) - Pre\_Amplifier Gain (dB)

Product	SENSOR	Test Engineer	Jason Gao
Test Site	AC1	Test Date	2020/03/26
Test Mode	Co-location mode (Bluetooth-LE + LoRa)		
Remark	1. Average measurement was not performed if peak level lower than average limit. 2. Other frequency was 20dB below limit line within 1-18GHz, there is not show in the report.		

Mark	Frequency (MHz)	Reading Level (dBμV)	Factor (dB)	Measure Level (dBμV/m)	Limit (dBμV/m)	Margin (dB)	Detector	Polarization
	1544.0	40.1	-4.4	35.7	74.0	-38.3	Peak	Horizontal
	3533.0	38.4	2.0	40.4	74.0	-33.6	Peak	Horizontal
	7502.5	38.8	10.8	49.6	74.0	-24.4	Peak	Horizontal
	2079.5	39.2	-1.7	37.5	74.0	-36.5	Peak	Vertical
	4519.0	39.9	5.0	44.9	74.0	-29.1	Peak	Vertical
	6040.5	38.6	6.9	45.5	74.0	-28.5	Peak	Vertical

Note 1: "\*" means test frequency did not fall into restricted band.

Note 2: Measure Level (dBμV/m) = Reading Level (dBμV) + Factor (dB)

Factor (dB) = Cable Loss (dB) + Antenna Factor (dB/m) - Pre\_Amplifier Gain (dB)



**The Worst Case of Radiated Emission below 1GHz:**

Site: AC1	Time: 2020/03/30 - 20:23
Limit: FCC_Part15.209_RE(3m)	Engineer: Buter Shi
Probe: AC1_VULB 9168 _20-2000MHz	Polarity: Horizontal
EUT: SENSOR	Power: By Battery
<b>Test Mode:</b> Transmit by Bluetooth-LE at Channel 2480MHz	

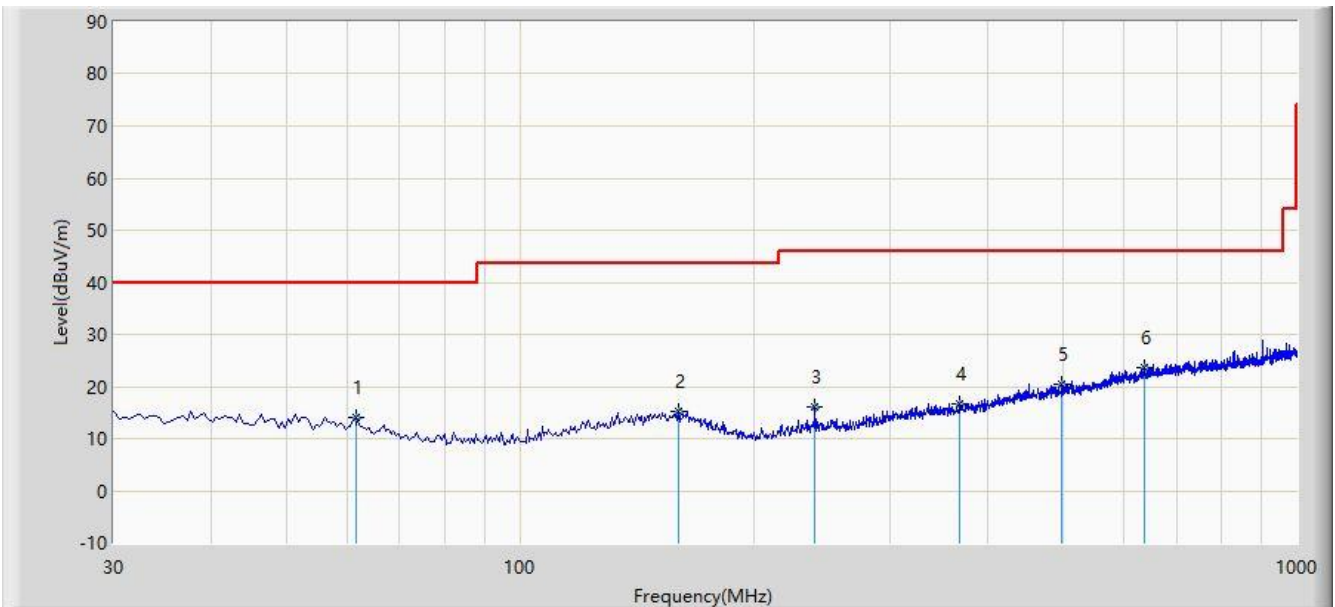

No	Flag	Mark	Frequency (MHz)	Measure Level (dBuV/m)	Reading Level (dBuV)	Margin (dB)	Limit (dBuV/m)	Factor (dB)	Type
1			61.525	14.085	0.957	-25.915	40.000	13.128	QP
2			159.980	15.277	0.053	-28.223	43.500	15.224	QP
3			240.005	16.030	3.200	-29.970	46.000	12.830	QP
4			368.530	16.555	0.657	-29.445	46.000	15.898	QP
5			498.025	20.531	2.070	-25.469	46.000	18.462	QP
6		*	637.705	23.742	2.468	-22.258	46.000	21.273	QP

Note 1: Measure Level (dB $\mu$ V/m) = Reading Level (dB $\mu$ V) + Factor (dB)

Factor (dB) = Cable Loss (dB) + Antenna Factor (dB/m)

Note 2: The amplitude of radiated emissions (frequency range from 9kHz ~ 30MHz and 18GHz to 40GHz) is that proximity to ambient noise, which also are attenuated more than 20 dB below the permissible value.

Therefore, the data is not presented in the report.

Site: AC1	Time: 2020/03/30 - 20:23
Limit: FCC_Part15.209_RE(3m)	Engineer: Buter Shi
Probe: AC1_VULB 9168 _20-2000MHz	Polarity: Vertical
EUT: SENSOR	Power: By Battery
<b>Test Mode:</b> Transmit by Bluetooth-LE at Channel 2480MHz	

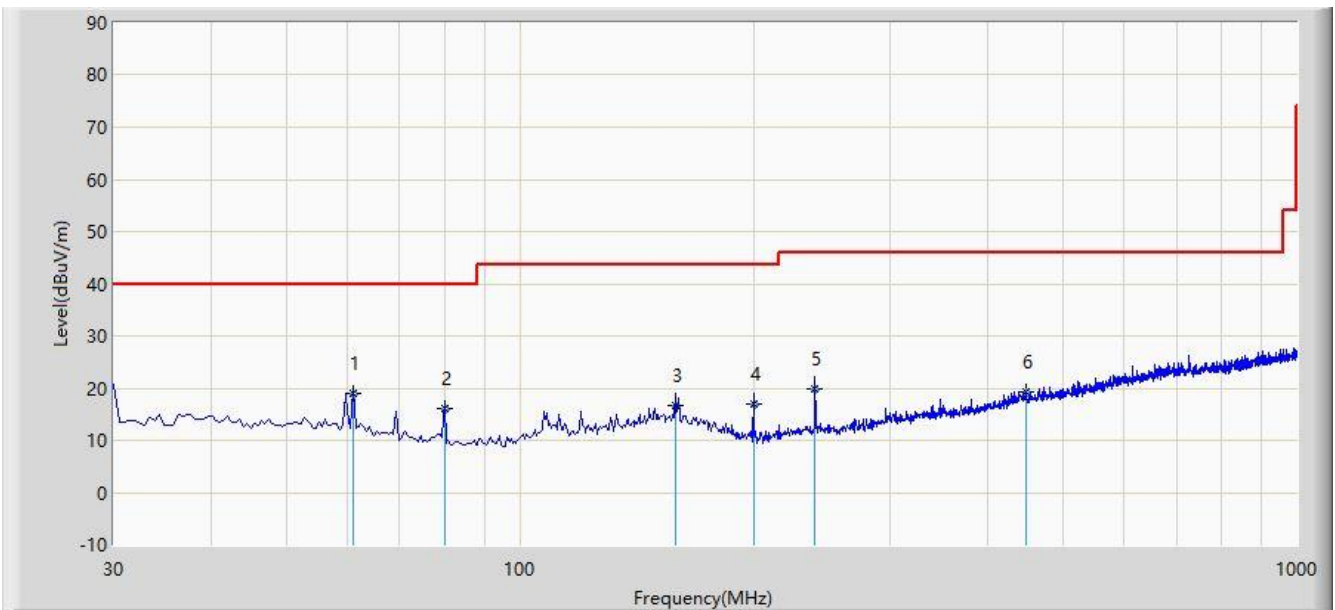

No	Flag	Mark	Frequency (MHz)	Measure Level (dBuV/m)	Reading Level (dBuV)	Margin (dB)	Limit (dBuV/m)	Factor (dB)	Type
1		*	61.040	19.040	5.830	-20.960	40.000	13.210	QP
2			79.955	15.965	5.830	-24.035	40.000	10.135	QP
3			158.525	16.786	1.530	-26.714	43.500	15.256	QP
4			199.750	17.019	5.840	-26.481	43.500	11.179	QP
5			240.005	19.970	7.140	-26.030	46.000	12.830	QP
6			448.070	19.380	1.579	-26.620	46.000	17.801	QP

Note 1: Measure Level (dB $\mu$ V/m) = Reading Level (dB $\mu$ V) + Factor (dB)

Factor (dB) = Cable Loss (dB) + Antenna Factor (dB/m)

Note 2: The amplitude of radiated emissions (frequency range from 9kHz ~ 30MHz and 18GHz to 40GHz) is that proximity to ambient noise, which also are attenuated more than 20 dB below the permissible value.

Therefore, the data is not presented in the report.

## 6.7. Radiated Restricted Band Edge Measurement

### 6.7.1. Test Limit

#### For 15.205 requirement:

Radiated emissions which fall in the restricted bands, as defined in Section 15.205(a) of FCC part 15, must also comply with the radiated emission limits specified in Section 15.209(a).

Frequency (MHz)	Frequency (MHz)	Frequency (MHz)	Frequency (GHz)
0.090 - 0.110	16.42 - 16.423	399.9 - 410	4.5 - 5.15
<sup>1</sup> 0.495 - 0.505	16.69475 - 16.69525	608 - 614	5.35 - 5.46
2.1735 - 2.1905	16.80425 - 16.80475	960 - 1240	7.25 - 7.75
4.125 - 4.128	25.5 - 25.67	1300 - 1427	8.025 - 8.5
4.17725 - 4.17775	37.5 - 38.25	1435 - 1626.5	9.0 - 9.2
4.20725 - 4.20775	73 - 74.6	1645.5 - 1646.5	9.3 - 9.5
6.215 - 6.218	74.8 - 75.2	1660 - 1710	10.6 - 12.7
6.26775 - 6.26825	108 - 121.94	1718.8 - 1722.2	13.25 - 13.4
6.31175 - 6.31225	123 - 138	2200 - 2300	14.47 - 14.5
8.291 - 8.294	149.9 - 150.05	2310 - 2390	15.35 - 16.2
8.362 - 8.366	156.52475 - 156.52525	2483.5 - 2500	17.7 - 21.4
8.37625 - 8.38675	156.7 - 156.9	2690 - 2900	22.01 - 23.12
8.41425 - 8.41475	162.0125 - 167.17	3260 - 3267	23.6 - 24.0
12.29 - 12.293	167.72 - 173.2	3332 - 3339	31.2 - 31.8
12.51975 - 12.52025	240 - 285	3345.8 - 3358	36.43 - 36.5
12.57675 - 12.57725	322 - 335.4	3600 - 4400	( <sup>2</sup> )
13.36 - 13.41	--	--	--

All out of band emissions appearing in a restricted band as specified in Section 15.205 of the Title 47 CFR must not exceed the limits shown in Table per Section 15.209.

FCC Part 15.209 Limits		
Frequency (MHz)	Field Strength ( $\mu\text{V/m}$ )	Measured Distance (m)
0.009 - 0.490	2400/F (kHz)	300
0.490 - 1.705	24000/F (kHz)	30
1.705 - 30	30	30
30 - 88	100	3
88 - 216	150	3
216 - 960	200	3
Above 960	500	3

### 6.7.2. Test Procedure Used

ANSI C63.10 - Section 6.3 (General Requirements)

ANSI C63.10 - Section 6.6 (Standard test method above 1GHz)

### 6.7.3. Test Setting

#### Peak Field Strength Measurements

1. Analyzer center frequency was set to the frequency of the radiated spurious emission of interest
2. RBW = 1MHz
3. VBW = 3MHz
4. Detector = Peak
5. Sweep time = Auto couple
6. Trace mode = Max hold
7. Trace was allowed to stabilize

### Average Field Strength Measurements

1. Analyzer center frequency was set to the frequency of the radiated spurious emission of interest
2. RBW = 1MHz
3. VBW; If the EUT is configured to transmit with duty cycle  $\geq 98\%$ , set VBW = 10Hz
4. If the EUT duty cycle is  $< 98\%$ , set VBW  $\geq 1/T$ . T is the minimum transmission duration
5. Detector = Peak
6. Sweep time = Auto
7. Trace mode = Max hold
8. Trace was allowed to stabilize

#### 6.7.4. Test Setup

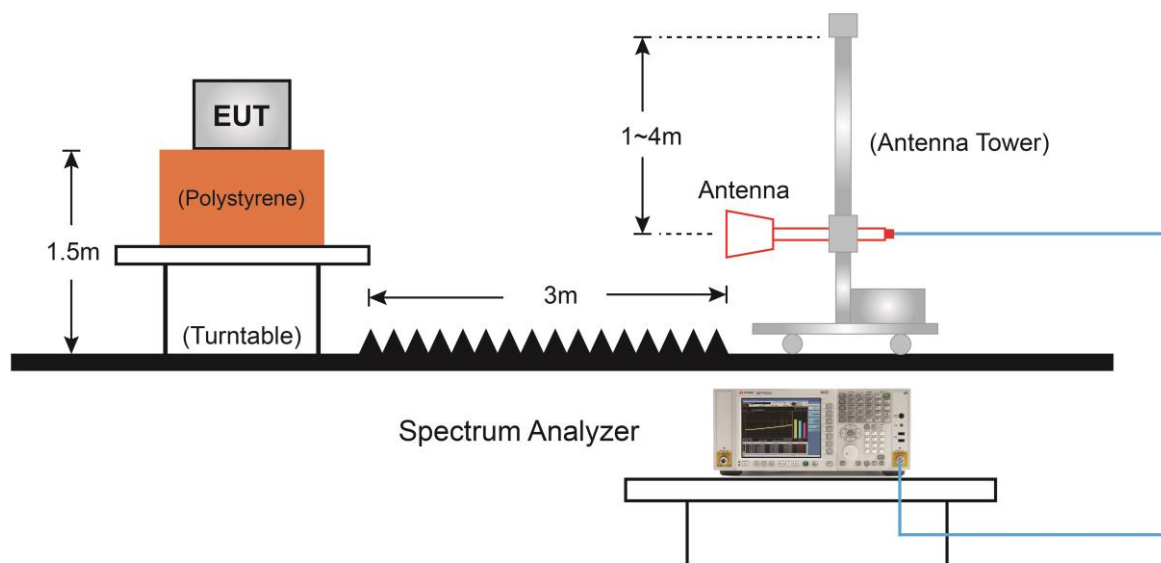

### 6.7.5. Test Result

Site: AC1	Time: 2020/03/26 - 14:30
Limit: FCC_Part15.209_RE(3m)	Engineer: Buter Shi
Probe: AC1_BBHA9120D_1-18GHz	Polarity: Horizontal
EUT: SENSOR	Power: By Battery
Test Mode: Transmit by Bluetooth-LE at Channel 2402MHz	

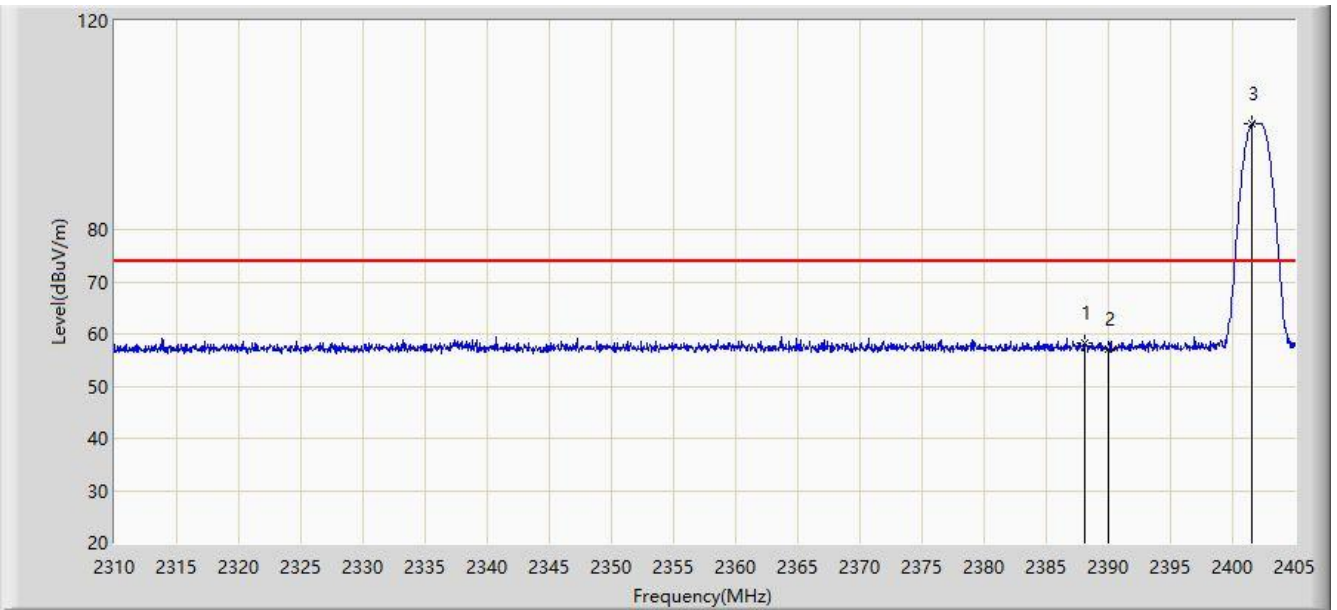

No	Flag	Mark	Frequency (MHz)	Measure Level (dBuV/m)	Reading Level (dBuV)	Margin (dB)	Limit (dBuV/m)	Factor (dB)	Type
1			2388.137	58.154	26.081	-15.846	74.000	32.072	PK
2			2390.000	57.164	25.092	-16.836	74.000	32.072	PK
3		*	2401.580	100.334	68.259	N/A	N/A	32.076	PK

Note: Measure Level (dB $\mu$ V/m) = Reading Level (dB $\mu$ V) + Factor (dB)

Factor (dB) = Cable Loss (dB) + Antenna Factor (dB/m)

Site: AC1	Time: 2020/03/26 - 14:31
Limit: FCC_Part15.209_RE(3m)	Engineer: Buter Shi
Probe: AC1_BBHA9120D_1-18GHz	Polarity: Horizontal
EUT: SENSOR	Power: By Battery
Test Mode: Transmit by Bluetooth-LE at Channel 2402MHz	

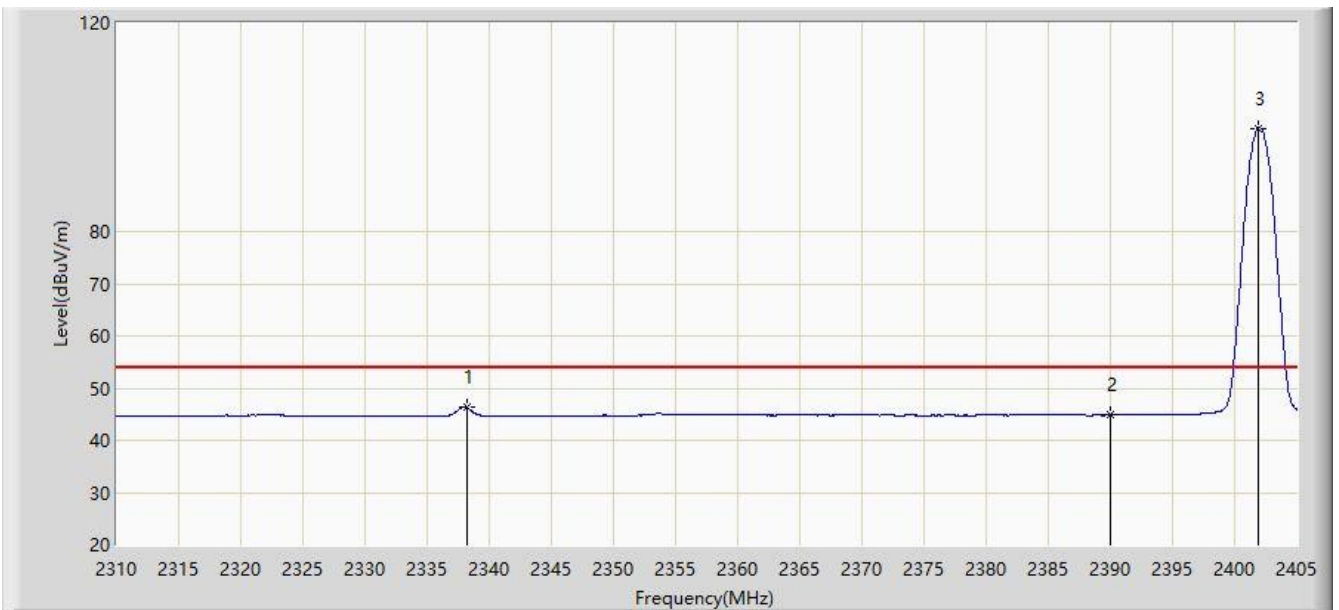

No	Flag	Mark	Frequency (MHz)	Measure Level (dBuV/m)	Reading Level (dBuV)	Margin (dB)	Limit (dBuV/m)	Factor (dB)	Type
1			2338.167	46.334	14.185	-7.666	54.000	32.149	AV
2			2390.000	44.818	12.746	-9.182	54.000	32.072	AV
3		*	2401.865	99.760	67.685	N/A	N/A	32.075	AV

Note: Measure Level (dB $\mu$ V/m) = Reading Level (dB $\mu$ V) + Factor (dB)

Factor (dB) = Cable Loss (dB) + Antenna Factor (dB/m)

Site: AC1	Time: 2020/03/26 - 14:35
Limit: FCC_Part15.209_RE(3m)	Engineer: Buter Shi
Probe: AC1_BBHA9120D_1-18GHz	Polarity: Vertical
EUT: SENSOR	Power: By Battery
Test Mode: Transmit by Bluetooth-LE at Channel 2402MHz	

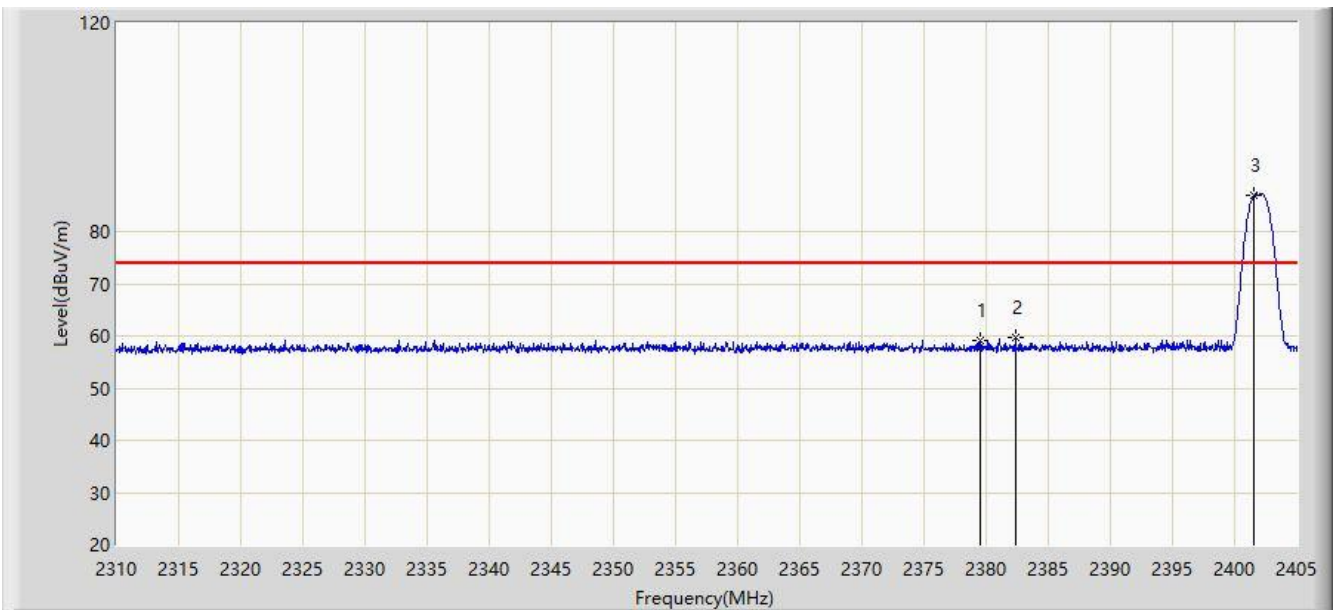

No	Flag	Mark	Frequency (MHz)	Measure Level (dBuV/m)	Reading Level (dBuV)	Margin (dB)	Limit (dBuV/m)	Factor (dB)	Type
1			2379.492	59.002	26.927	-14.998	74.000	32.075	PK
2			2382.343	59.599	27.525	-14.401	74.000	32.074	PK
3		*	2401.580	87.034	54.959	N/A	N/A	32.076	PK

Note: Measure Level (dB $\mu$ V/m) = Reading Level (dB $\mu$ V) + Factor (dB)

Factor (dB) = Cable Loss (dB) + Antenna Factor (dB/m)



Site: AC1	Time: 2020/03/26 - 14:37
Limit: FCC_Part15.209_RE(3m)	Engineer: Buter Shi
Probe: AC1_BBHA9120D_1-18GHz	Polarity: Vertical
EUT: SENSOR	Power: By Battery
Test Mode: Transmit by Bluetooth-LE at Channel 2402MHz	

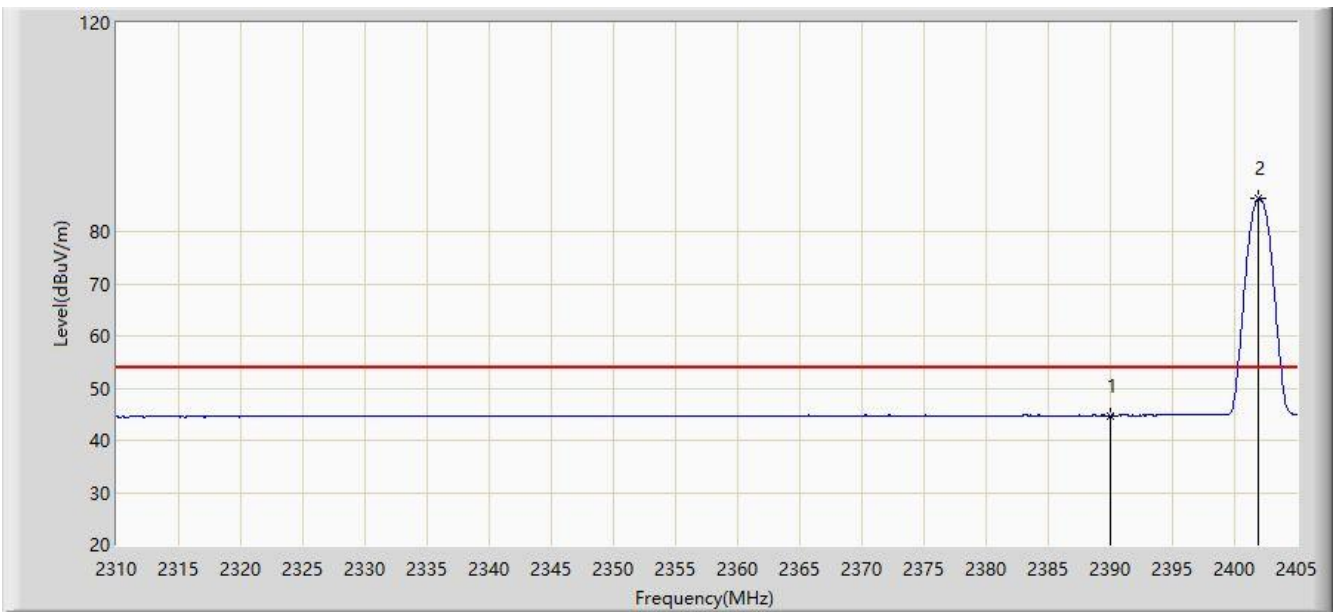

No	Flag	Mark	Frequency (MHz)	Measure Level (dBuV/m)	Reading Level (dBuV)	Margin (dB)	Limit (dBuV/m)	Factor (dB)	Type
1			2390.000	44.754	12.682	-9.246	54.000	32.072	AV
2		*	2401.913	86.409	54.334	N/A	N/A	32.075	AV

Note: Measure Level (dB $\mu$ V/m) = Reading Level (dB $\mu$ V) + Factor (dB)

Factor (dB) = Cable Loss (dB) + Antenna Factor (dB/m)

Site: AC1	Time: 2020/03/26 - 14:38
Limit: FCC_Part15.209_RE(3m)	Engineer: Buter Shi
Probe: AC1_BBHA9120D_1-18GHz	Polarity: Horizontal
EUT: SENSOR	Power: By Battery
Test Mode: Transmit by Bluetooth-LE at Channel 2480MHz	

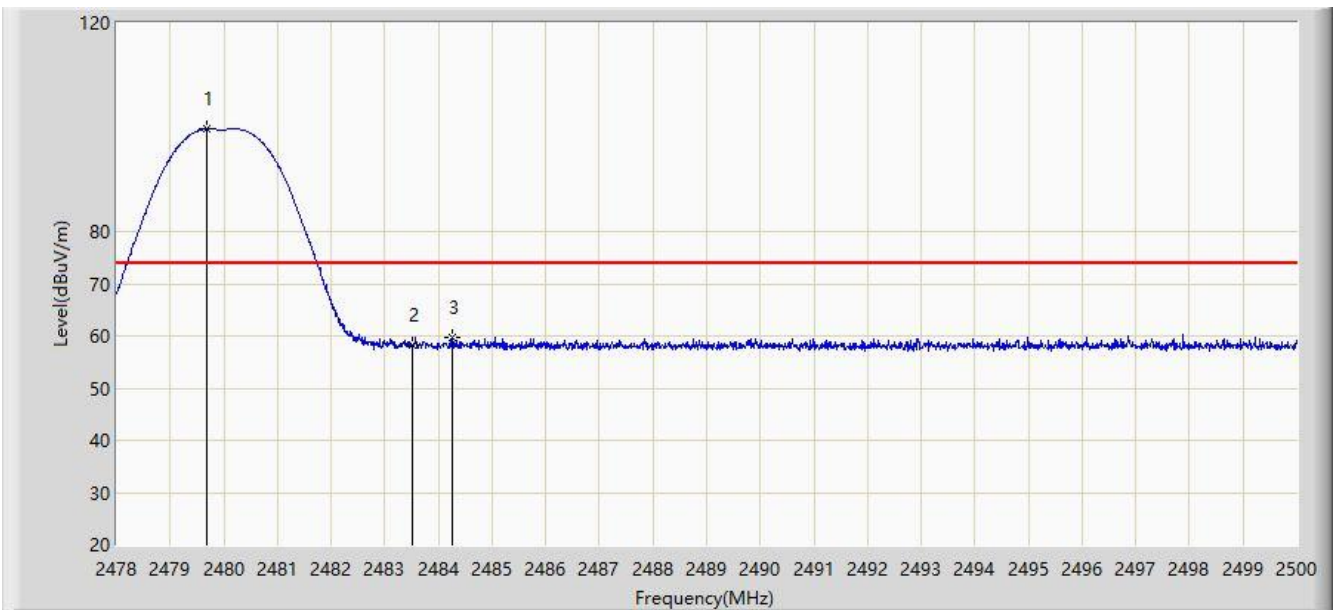

No	Flag	Mark	Frequency (MHz)	Measure Level (dBuV/m)	Reading Level (dBuV)	Margin (dB)	Limit (dBuV/m)	Factor (dB)	Type
1		*	2479.683	99.661	67.617	N/A	N/A	32.044	PK
2			2483.500	58.402	26.365	-15.598	74.000	32.037	PK
3			2484.270	59.781	27.745	-14.219	74.000	32.036	PK

Note: Measure Level (dB $\mu$ V/m) = Reading Level (dB $\mu$ V) + Factor (dB)

Factor (dB) = Cable Loss (dB) + Antenna Factor (dB/m)

Site: AC1	Time: 2020/03/26 - 14:41
Limit: FCC_Part15.209_RE(3m)	Engineer: Buter Shi
Probe: AC1_BBHA9120D_1-18GHz	Polarity: Horizontal
EUT: SENSOR	Power: By Battery
Test Mode: Transmit by Bluetooth-LE at Channel 2480MHz	

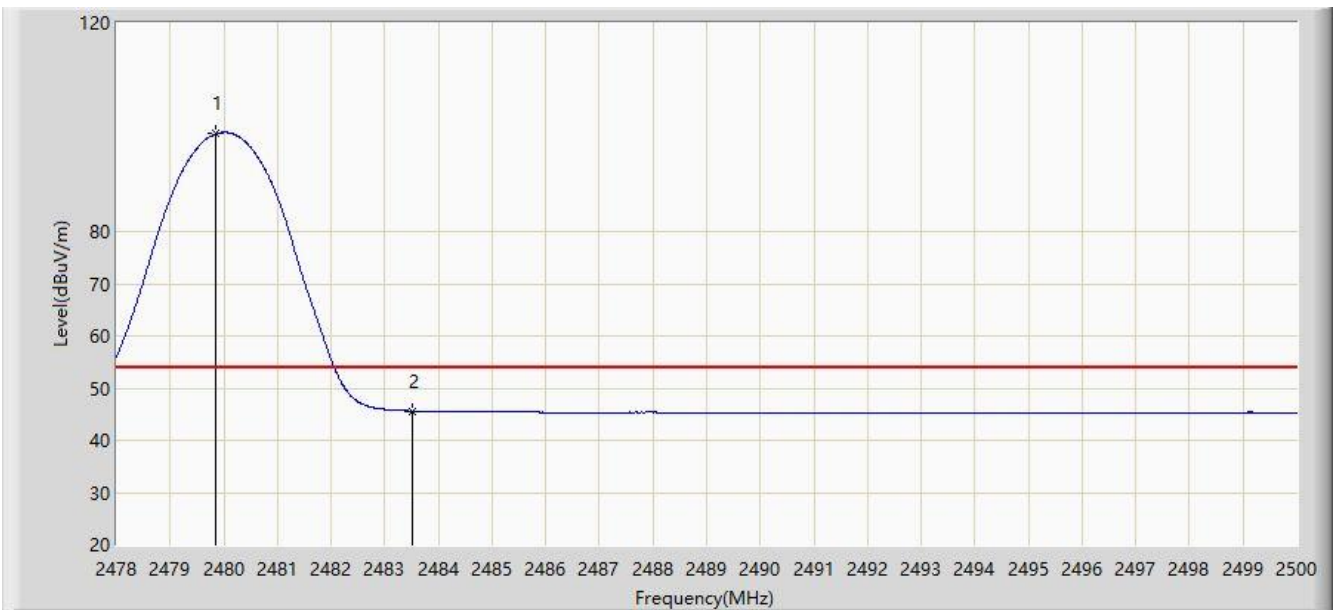

No	Flag	Mark	Frequency (MHz)	Measure Level (dBuV/m)	Reading Level (dBuV)	Margin (dB)	Limit (dBuV/m)	Factor (dB)	Type
1		*	2479.848	98.752	66.708	N/A	N/A	32.044	AV
2			2483.500	45.635	13.598	-8.365	54.000	32.037	AV

Note: Measure Level (dB $\mu$ V/m) = Reading Level (dB $\mu$ V) + Factor (dB)

Factor (dB) = Cable Loss (dB) + Antenna Factor (dB/m)

Site: AC1	Time: 2020/03/26 - 14:43
Limit: FCC_Part15.209_RE(3m)	Engineer: Buter Shi
Probe: AC1_BBHA9120D_1-18GHz	Polarity: Vertical
EUT: SENSOR	Power: By Battery
Test Mode: Transmit by Bluetooth-LE at Channel 2480MHz	

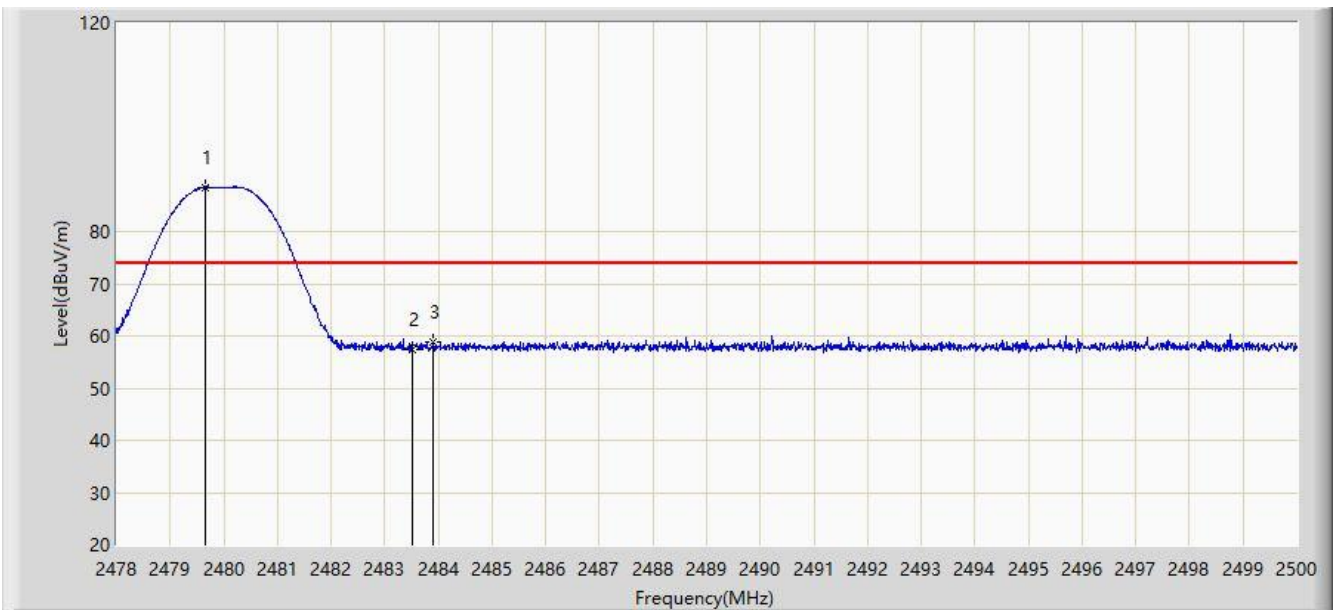

No	Flag	Mark	Frequency (MHz)	Measure Level (dBuV/m)	Reading Level (dBuV)	Margin (dB)	Limit (dBuV/m)	Factor (dB)	Type
1		*	2479.650	88.539	56.495	N/A	N/A	32.044	PK
2			2483.500	57.288	25.251	-16.712	74.000	32.037	PK
3			2483.907	58.878	26.842	-15.122	74.000	32.036	PK

Note: Measure Level (dB $\mu$ V/m) = Reading Level (dB $\mu$ V) + Factor (dB)

Factor (dB) = Cable Loss (dB) + Antenna Factor (dB/m)

Site: AC1	Time: 2020/03/26 - 14:44
Limit: FCC_Part15.209_RE(3m)	Engineer: Buter Shi
Probe: AC1_BBHA9120D_1-18GHz	Polarity: Vertical
EUT: SENSOR	Power: By Battery
Test Mode: Transmit by Bluetooth-LE at Channel 2480MHz	

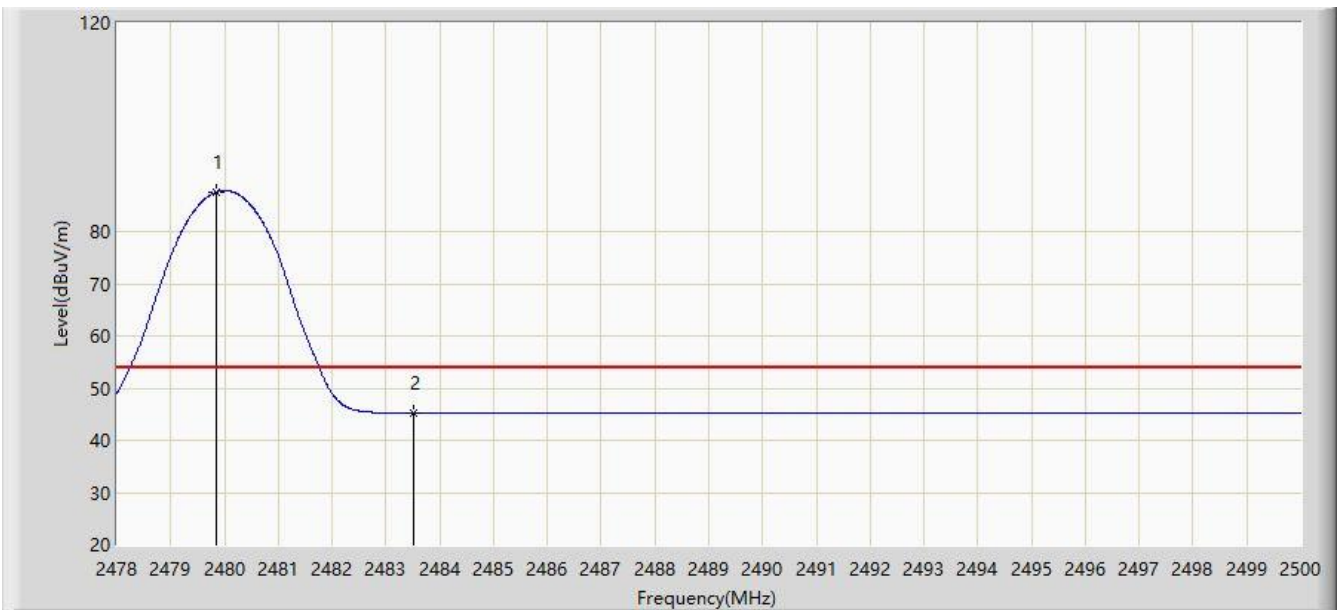

No	Flag	Mark	Frequency (MHz)	Measure Level (dBuV/m)	Reading Level (dBuV)	Margin (dB)	Limit (dBuV/m)	Factor (dB)	Type
1		*	2479.848	87.569	55.525	N/A	N/A	32.044	AV
2			2483.500	45.199	13.162	-8.801	54.000	32.037	AV

Note: Measure Level (dBuV/m) = Reading Level (dBuV) + Factor (dB)

Factor (dB) = Cable Loss (dB) + Antenna Factor (dB/m)

## 6.8. AC Conducted Emissions Measurement

### 6.8.1. Test Limit

FCC Part 15.207 Limits		
Frequency (MHz)	QP (dB $\mu$ V)	Average (dB $\mu$ V)
0.15 - 0.50	66 - 56	56 - 46
0.50 - 5.0	56	46
5.0 - 30	60	50

Note 1: The lower limit shall apply at the transition frequencies.

Note 2: The limit decreases linearly with the logarithm of the frequency in the range 0.15MHz to 0.5MHz.

### 6.8.2. Test Setup

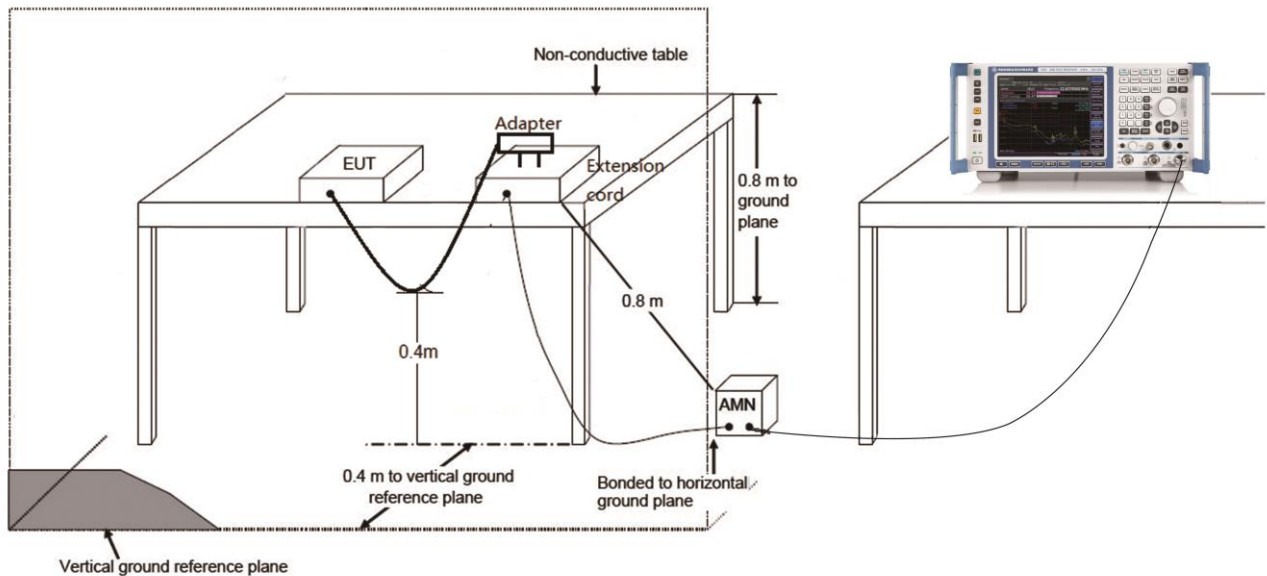

### 6.8.3. Test Result

The EUT is powered by battery, so this test item is not applicable.

## 7. CONCLUSION

The data collected relate only the item(s) tested and show that the unit is in compliance with Part 15C of the FCC rules.

————— The End —————

## **Appendix A - Test Setup Photograph**

Refer to "2003RSU050-UT" file.



## **Appendix B - EUT Photograph**

Refer to "2003RSU050-UE" file.