



RADIO TEST REPORT

FCC ID : 2AHXD-5313794
Equipment : CarBack Radar
Brand Name : TREK
Model Name : 5313794
Applicant : Trek Bicycle Corporation
801 W Madison St, Waterloo, WI 53594
Manufacturer : Universal Microelectronics co.,LTD
3,27TH RD.,Taichung Industrial Park.Taichung, Taiwan
Standard : 47 CFR FCC Part 95M

The product was received on Jun. 19, 2023, and testing was started from Aug. 11, 2023 and completed on Nov. 01, 2023. We, Sporton International Inc. Hsinchu Laboratory, would like to declare that the tested sample has been evaluated in accordance with the procedures given in ANSI C63.10-2013 and shown compliance with the applicable technical standards.

The test results in this report apply exclusively to the tested model / sample. Without written approval of Sporton International Inc. Hsinchu Laboratory, the test report shall not be reproduced except in full.



Approved by: Sam Chen

Sporton International Inc. Hsinchu Laboratory
No.8, Ln. 724, Bo'ai St., Zhubei City, Hsinchu County 302010, Taiwan (R.O.C.)



Table of Contents

History of this test report.....3

Summary of Test Result.....4

1 General Description5

1.1 Information.....5

1.2 Applicable Standards6

1.3 Testing Location Information6

1.4 Measurement Uncertainty6

2 Test Configuration of EUT7

2.1 Test Channel Frequencies Configuration.....7

2.2 Conformance Tests and Related Test Frequencies.....7

2.3 The Worst Case Measurement Configuration7

2.4 EUT Operation during Test8

2.5 Accessories8

2.6 Support Equipment.....9

2.7 Far Field Boundary Calculations9

2.8 Test Setup Diagram10

3 Transmitter Test Result12

3.1 Occupied Bandwidth12

3.2 Radiated E.I.R.P Power14

3.3 Transmitter Radiated Unwanted Emissions16

3.4 Frequency Stability.....26

4 Test Equipment and Calibration Data28

Appendix A. Test Photos

Photographs of EUT v01



Summary of Test Result

Report Clause	Ref Std. Clause	Test Items	Result (PASS/FAIL)	Remark
3.1	95.303	Occupied Bandwidth	PASS	-
3.2	95.3367	Radiated E.I.R.P Power	PASS	-
3.3	95.3379	Transmitter Radiated Unwanted Emissions	PASS	-
3.4	95.3379	Frequency Stability	PASS	-

Note: Reference to Sporton Project No.: 360116

Conformity Assessment Condition:

1. The test results (PASS/FAIL) with all measurement uncertainty excluded are presented against the regulation limits or in accordance with the requirements stipulated by the applicant/manufacturer who shall bear all the risks of non-compliance that may potentially occur if measurement uncertainty is taken into account.
2. The measurement uncertainty please refer to each test result in the chapter "Measurement Uncertainty".

Disclaimer:

The product specifications of the EUT presented in the test report that may affect the test assessments are declared by the manufacturer who shall take full responsibility for the authenticity.

Reviewed by: **Sam Chen**

Report Producer: **Sandy Chuang**



1 General Description

1.1 Information

1.1.1 RF General Information

RF General Information			
Frequency Range (GHz)	Operating Frequency Range (GHz)	Test Frequency (GHz)	Modulation
76-81	76.15-76.31	76.2315	FMCW

1.1.2 Antenna Information

Ant.	Port		Brand	Model Name	Antenna Type	Connector	Gain (dBi)
	Bluetooth / ANT plus	76~81GHz TX RX					
1	-	1~3 1~6	UMEC	S78*	Patch	N/A	11.2
2	1	- -	JOHANSON	2450AT18D0100E	Chip	N/A	1.5

Note 1: The above information was declared by manufacturer.

Note 2: The Bluetooth and ANT plus cannot function at the same time.

Note 3: **For Bluetooth function (1TX/1RX):**

Only Port 1 can be used as transmitting/receiving antenna.

For ANT plus function (1TX/1RX):

Only Port 1 can be used as transmitting/receiving antenna.

For 76~81GHz function (3TX/6RX):

Port 1~3 can be used as transmitting antenna.

Port 1~3 could transmit simultaneously.

Port 1~6 can be used as receiving antenna.

Port 1~6 could receive simultaneously.

1.1.3 EUT Operational Condition

EUT Power Type	From Battery or Host system			
Supply Voltage	<input type="checkbox"/>	AC	State AC voltage	-
Supply Voltage	<input checked="" type="checkbox"/>	DC	State DC voltage	5

1.1.4 Test Signal Duty Cycle

Test Signal Duty Cycle
<input checked="" type="checkbox"/> Continuous transmission – 0.6%
<input type="checkbox"/> Transmissions occur regularly in time - ...%



1.2 Applicable Standards

According to the specifications of the manufacturer, the EUT must comply with the requirements of the following standards:

- ♦ 47 CFR FCC Part 95M
- ♦ ANSI C63.10 - Testing Unlicensed Wireless Devices
- ♦ KDB653005 D01 76-81 GHz Radars v01r02

The following reference test guidance is not within the scope of accreditation of TAF.

- ♦ FCC KDB 414788 D01 v01r01

1.3 Testing Location Information

Testing Location Information	
Test Lab. : Sporton International Inc. Hsinchu Laboratory	
Hsinchu	ADD: No.8, Ln. 724, Bo'ai St., Zhubei City, Hsinchu County 302010, Taiwan (R.O.C.)
(TAF: 3787)	TEL: 886-3-656-9065 FAX: 886-3-656-9085
	Test site Designation No. TW3787 with FCC.
	Conformity Assessment Body Identifier (CABID) TW3787 with ISED.

Test Condition	Test Site No.	Test Engineer	Test Environment (°C / %)	Test Date
Radiated – Frequency Stability	TH03-CB	Gino Huang	23.7~24.3 / 58~63	Aug. 11, 2023
Radiated < 1GHz – Other tests	03CH04-CB	Gordon Hong	22.4~23.5 / 55~58	Aug. 11, 2023~ Nov. 01, 2023
Radiated > 1GHz – Other tests	03CH01-CB	Chris Lee	21.7~22.9 / 58~62	Aug. 11, 2023~ Oct. 13, 2023
	03CH03-CB		22~22.9 / 59~61	

1.4 Measurement Uncertainty

ISO/IEC 17025 requires that an estimate of the measurement uncertainties associated with the emissions test results be included in the report. The measurement uncertainties given below are based on a 95% confidence level (based on a coverage factor (k=2))

Test Items	Uncertainty	Remark
Radiated Emission (9kHz ~ 30MHz)	3.7 dB	Confidence levels of 95%
Radiated Emission (30MHz ~ 1,000MHz)	5.1 dB	Confidence levels of 95%
Radiated Emission (1GHz ~ 18GHz)	4.1 dB	Confidence levels of 95%
Radiated Emission (18GHz ~ 40GHz)	4.2 dB	Confidence levels of 95%
Radiated Emission (40GHz ~ 60GHz)	3.0 dB	Confidence levels of 95%
Radiated Emission (60GHz ~ 90GHz)	3.0 dB	Confidence levels of 95%
Radiated Emission (90GHz ~ 200GHz)	4.3 dB	Confidence levels of 95%
Radiated Emission (200GHz ~ 280GHz)	5.0 dB	Confidence levels of 95%
Temperature	1.3°C	Confidence levels of 95%



2 Test Configuration of EUT

2.1 Test Channel Frequencies Configuration

Test Software Version	nRF Connect Version 4.26.
Test Frequencies (GHz)	76.2315
Software Setting	Default

2.2 Conformance Tests and Related Test Frequencies

Test Item	Test Frequencies (GHz)
Occupied Bandwidth	76.2315
Radiated E.I.R.P Power	76.2315
Transmitter Spurious Emissions (below 1 GHz)	Random
Transmitter Spurious Emissions (1 GHz-40 GHz)	76.2315
Transmitter Spurious Emissions (above 40 GHz)	76.2315
Frequency Stability	76.2315

2.3 The Worst Case Measurement Configuration

The Worst Case Mode for Following Conformance Tests	
Tests Item	Occupied Bandwidth Radiated E.I.R.P Power Frequency Stability
Test Condition	Radiated measurement
Operating Mode	CTX
	After evaluating, EUT in Y axis was the worst case, so the measurement will follow this same test configuration.
1	EUT in Y axis

The Worst Case Mode for Following Conformance Tests	
Tests Item	Transmitter Radiated Unwanted Emissions
Test Condition	Radiated measurement
Operating Mode < 1GHz	Normal link
	After evaluating, EUT in Y axis was the worst case, so the measurement will follow this same test configuration.
1	EUT in Y axis_76~81GHz + ANT plus (Powered by Host system)
2	EUT in Y axis_76~81GHz + ANT plus (Powered by Adapter)
3	EUT in Y axis_76~81GHz + ANT plus (Powered by Battery)



Mode 1 has been evaluated to be the worst case among Mode 1~3, thus measurement for Mode 4 will follow this same test mode.	
4	EUT in Y axis_76~81GHz + Bluetooth (Powered by Host system)
For operating, mode 4 is the worst case and it was record in this test report.	
Operating Mode > 1GHz	CTX
	After evaluating, EUT in Y axis was the worst case, so the measurement will follow this same test configuration.
1	EUT in Y axis

The Worst Case Mode for Following Conformance Tests	
Tests Item	Simultaneous Transmission Analysis - Co-location RF Exposure Evaluation
Operating Mode	
1	76~81GHz + Bluetooth
2	76~81GHz + ANT plus
Refer to Sporton Test Report No.: FA360116-03 for Co-location RF Exposure Evaluation.	

Note: The adapter was for measurement only and would not be marketed. Its information is shown as below:

Equipment	Brand Name	Model Name
Adapter	XIAOMI	MDY-09-EA

2.4 EUT Operation during Test

For CTX Mode:

The EUT was programmed to be in continuously transmitting mode.

For Normal Link Mode:

During the test, the EUT operation to normal function.

2.5 Accessories

Accessories
USB cable*1: Shielded, 1.5m
Lithium-ion battery*1



2.6 Support Equipment

For Radiated < 1GHz (Other tests):

Support Equipment				
No.	Equipment	Brand Name	Model Name	FCC ID
A	NB	DELL	E4300	N/A
B	Smart phone	Nokia	TA-1062	N/A
C	Earphone	SHYARO CHI	MIC-04	N/A
D	Mouse	Logitech	M-U0026	N/A

For Radiated (Frequency Stability) and Radiated > 1GHz (Other tests):

Support Equipment				
No.	Equipment	Brand Name	Model Name	FCC ID
A	Notebook	DELL	E4300	N/A

2.7 Far Field Boundary Calculations

The far-field boundary is given as:

$$\text{far field} = (2 * L^2) / \lambda$$

where:

L = Largest Antenna Dimension, including the reflector, in meters

λ = wavelength in meters

Far Field (m)				
Frequency (GHz)	L (m)	Lambda (m)	d(Far Field) (m)	d(Far Field) (cm)
76.2315	0.01314	0.0039354	0.088	8.77

2.8 Test Setup Diagram

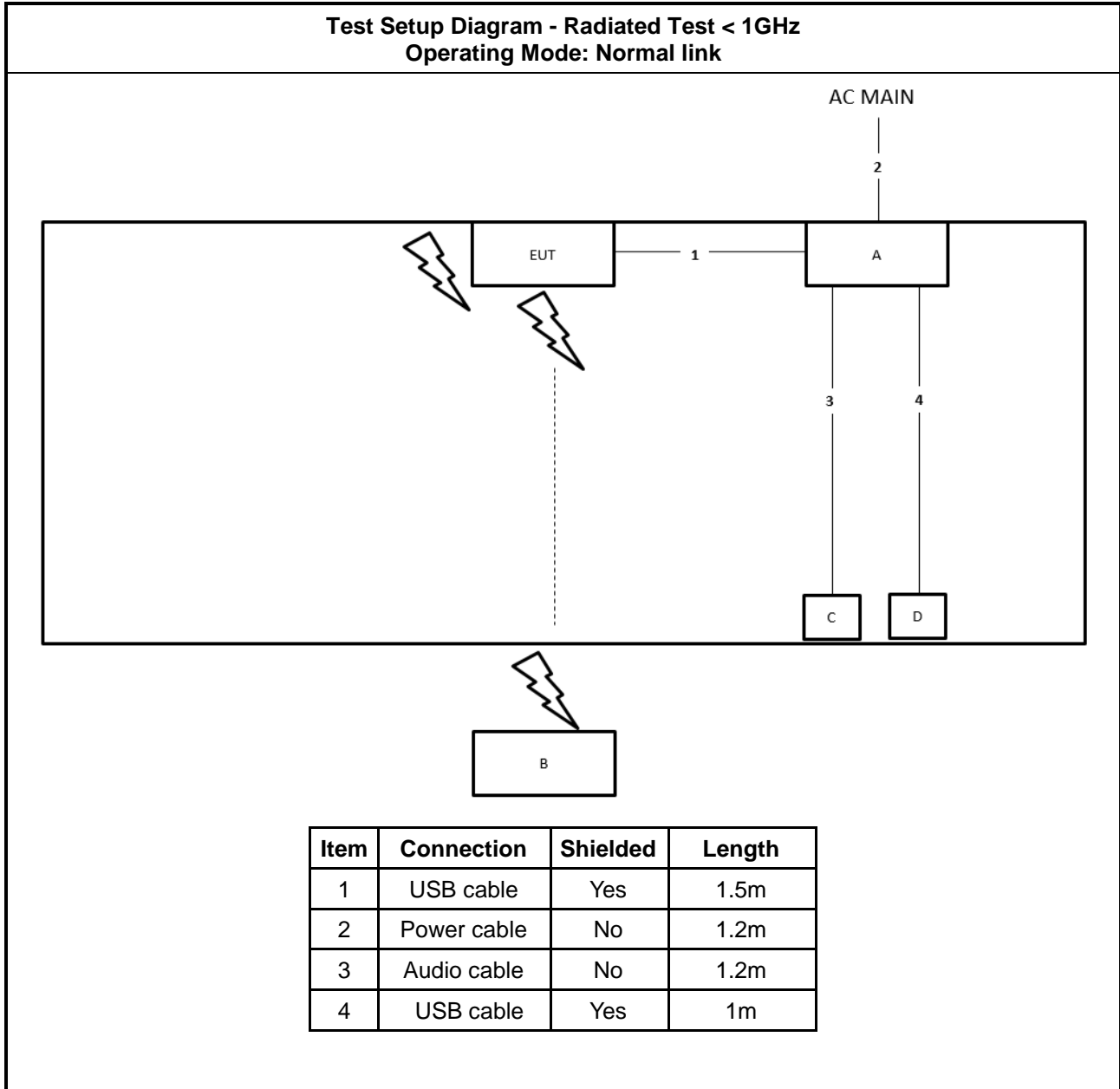



**Test Setup Diagram - Radiated Test
Operating Mode: CTX**

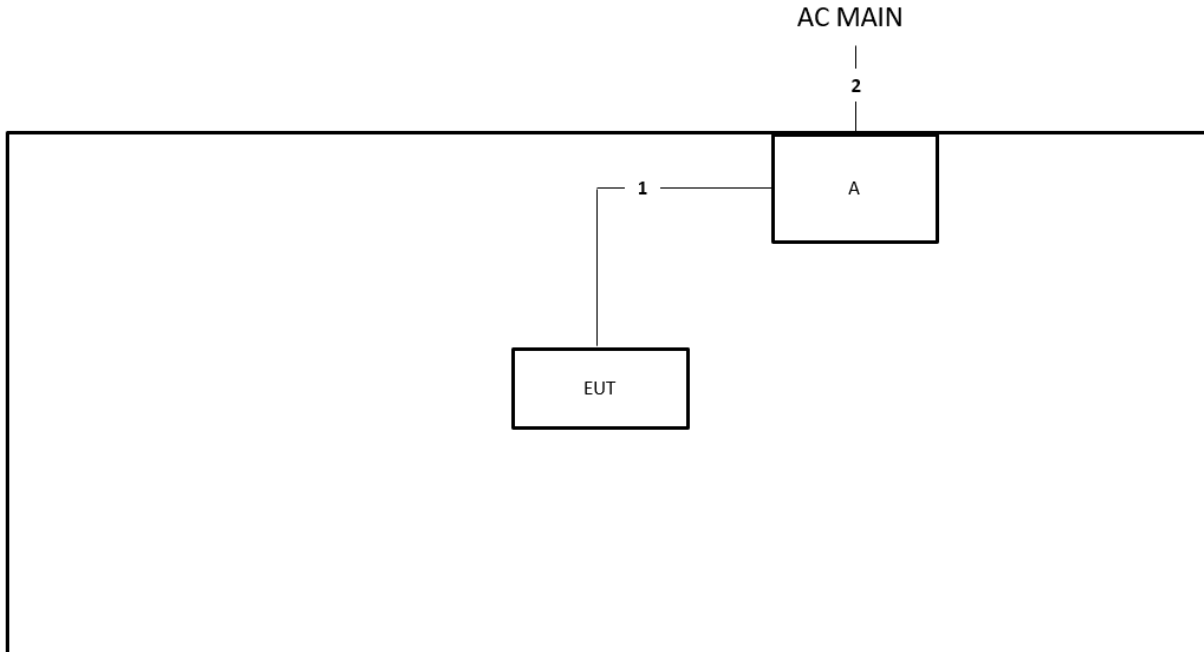

Item	Connection	Shielded	Length
1	USB cable	Yes	1.5m
2	Power cable	No	1.2m

3 Transmitter Test Result

3.1 Occupied Bandwidth

3.1.1 Occupied Bandwidth (OBW) Limit

Occupied Bandwidth (EBW) Limit
Information only

3.1.2 Measuring Instruments

Refer a test equipment and calibration data table in this test report.

3.1.3 Test Procedures

Test Method	
<input checked="" type="checkbox"/>	For the Occupied bandwidth shall be measured using one of the options below:
<input checked="" type="checkbox"/>	Refer as ANSI C63.10, clause 7.8.7 for EBW measurement.
<input type="checkbox"/>	Refer as ANSI C63.10, clause 6.9.2 for occupied bandwidth testing.
<input checked="" type="checkbox"/>	Refer as ANSI C63.10, clause 9 for radiated measurement.
<input checked="" type="checkbox"/>	Radiated test was conducted at far-field distance. the distance from the radiating element of the EUT to the edge of the far field may be calculated from $[r \geq 2D^2/\lambda]$ r is the distance from the radiating element of the EUT to the edge of the far field, in m D is the largest dimension of both the radiating element and the test antenna (horn), in m λ is the wavelength of the emission under investigation $[300/f \text{ (MHz)}]$, in m

3.1.4 Test Setup

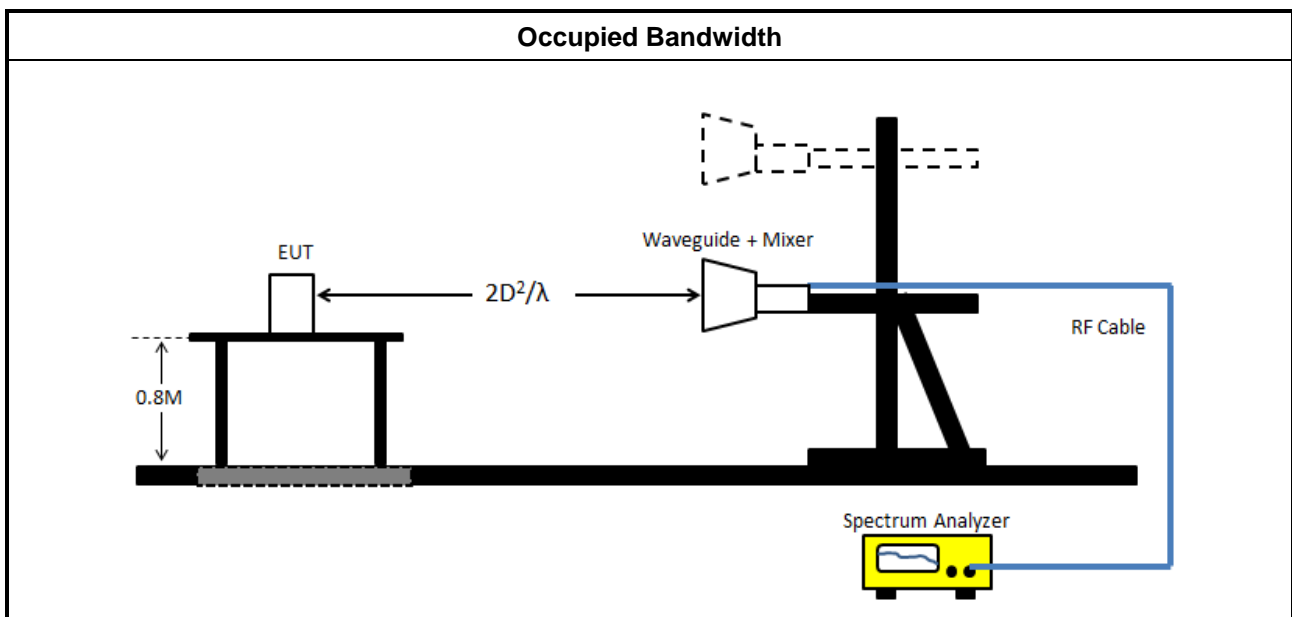



3.1.5 Test Result of Occupied Bandwidth

Test Results		
Test Freq. (GHz)	99% Occupied Bandwidth (MHz)	Limit (MHz)
76.2315	144.83	N/A

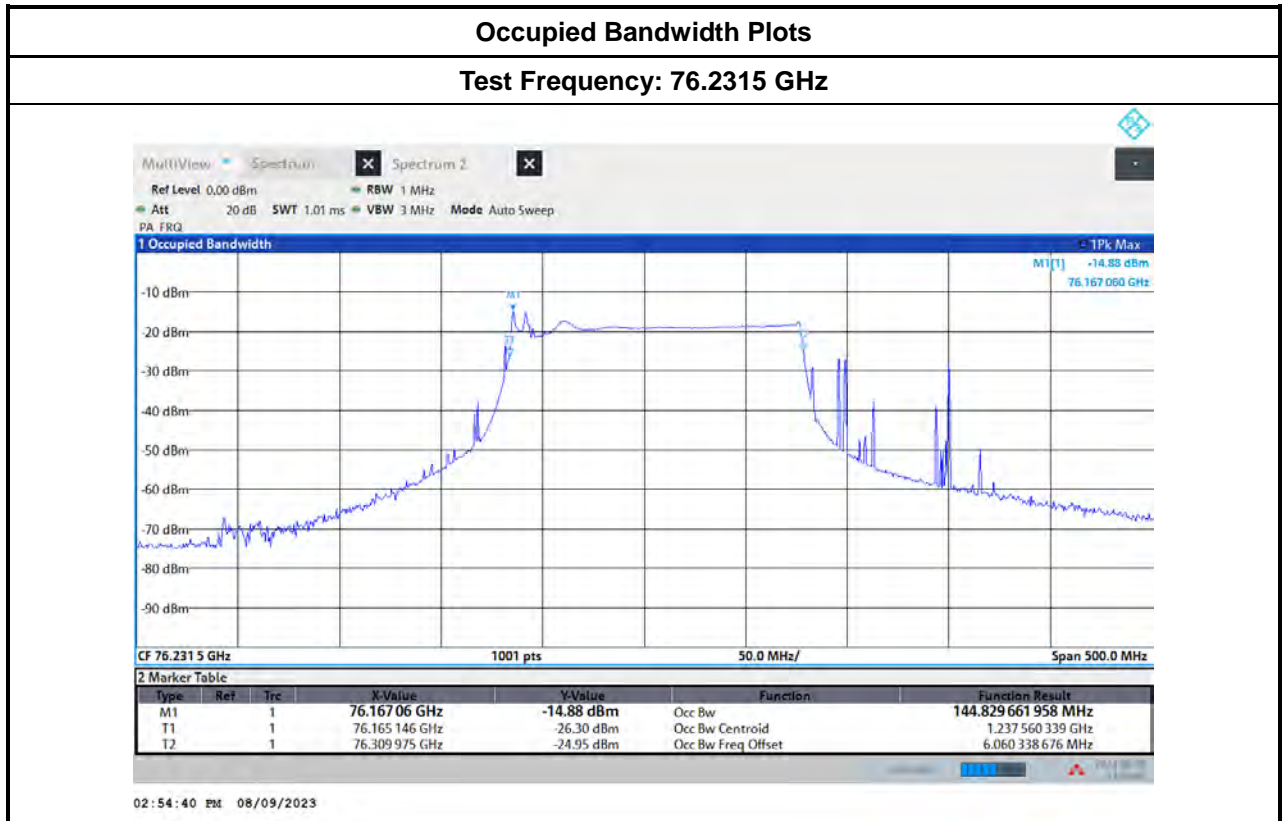



3.2 Radiated E.I.R.P Power

3.2.1 Radiated E.I.R.P Power

Radiated E.I.R.P Power	
<input checked="" type="checkbox"/>	76-81 GHz Band:
<input checked="" type="checkbox"/>	Peak: EIRP 55 dBm [279uW/cm ² at 3m] Average: EIRP 50 dBm [88uW/cm ² at 3m]

3.2.2 Measuring Instruments

Refer a test equipment and calibration data table in this test report.

3.2.3 Test Procedures

Test Method	
<input checked="" type="checkbox"/>	For the Occupied bandwidth shall be measured using one of the options below:
<input checked="" type="checkbox"/>	Refer as ANSI C63.10, clause 9 for radiated measurement.
<input checked="" type="checkbox"/>	Radiated test was conducted at far-field distance. the distance from the radiating element of the EUT to the edge of the far field may be calculated from $[r \geq 2D^2/\lambda]$ r is the distance from the radiating element of the EUT to the edge of the far field, in m D is the largest dimension of both the radiating element and the test antenna (horn), in m λ is the wavelength of the emission under investigation $[300/f \text{ (MHz)}]$, in m
<input checked="" type="checkbox"/>	The measured power level is converted to EIRP using the Friis equation: $E \text{ Meas} = 126.8 - 20\log(\lambda) + P - G$ where E is the field strength of the emission at the measurement distance, in dB μ V/m P is the power measured at the output of the test antenna, in dBm λ is the wavelength of the emission under investigation $[300/f\text{MHz}]$, in m G is the gain of the test antenna, in dBi $EIRP = E \text{ Meas} + 20 \log(d \text{ Meas}) - 104.7$ where EIRP : is the equivalent isotropically radiated power, in dBm. E Meas : is the field strength of the emission at the measurement distance, in dB μ V/m. d Meas : is the measurement distance, in m.

3.2.4 Test Setup

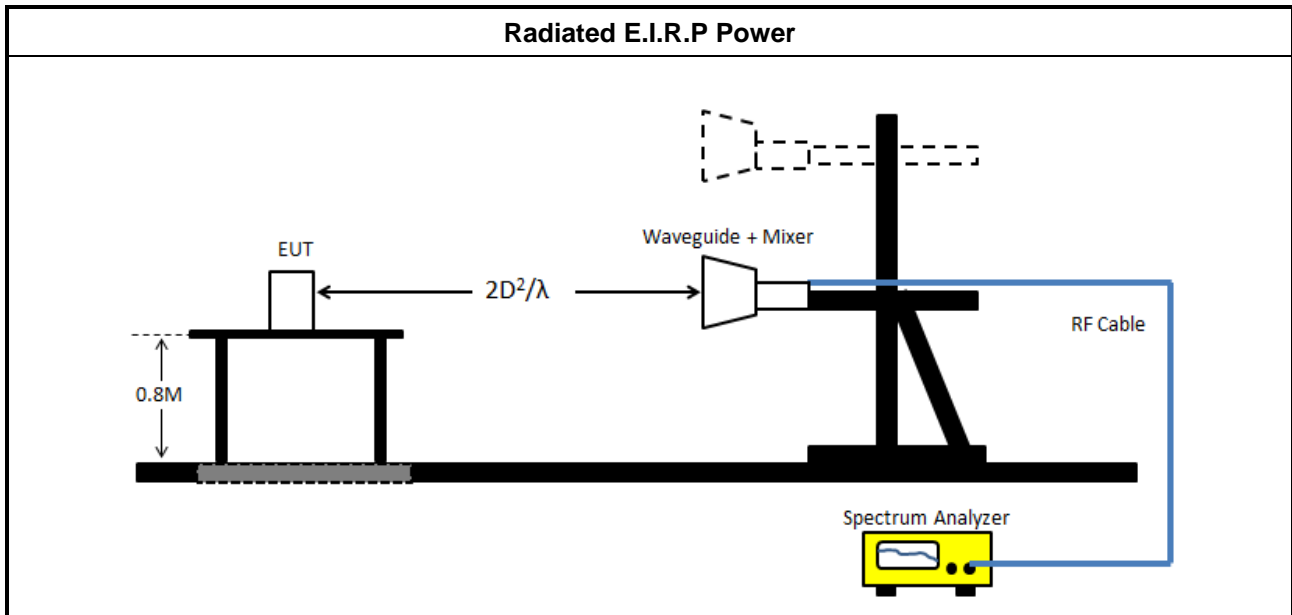

3.2.5 Measurement Results Calculation

The measured Level is calculated using:

$$EIRP = \text{Read Level} - \text{Rx Gain} + 20 * \text{LOG}(4 * 3.14159 * \text{Distance} / (300 / (\text{Test Freq.} * 1000)))$$

3.2.6 Test Result of Radiated E.I.R.P Power

Freq. (GHz)	Rx Gain (dBi)	P-Peak (dBm)	P-Average (dBm)	E-Meas-Peak (dBuV/m)	E-Meas-Average (dBuV/m)	Distance (m)	EIRP-Peak (dBm)	EIRP-Average (dBm)
76.2315	23.9	-14.4	-38.87	136.60	112.13	0.50	25.78	1.31
EIRP Limit							55	50



3.3 Transmitter Radiated Unwanted Emissions

3.3.1 Transmitter Radiated Unwanted Emissions Limit

Transmitter Radiated Unwanted Emissions Limit (Below 40 GHz)			
Frequency Range (MHz)	Field Strength (uV/m)	Field Strength (dBuV/m)	Measure Distance (m)
0.009~0.490	2400/F(kHz)	48.5 - 13.8	300
0.490~1.705	24000/F(kHz)	33.8 - 23	30
1.705~30.0	30	29	30
30~88	100	40	3
88~216	150	43.5	3
216~960	200	46	3
Above 960 - 40000	500	54	3

Frequency Range (GHz)	EIRP (dBm)	Power Density (pW/cm ² @ 3m)
40 - 200	-1.7	600
200 - 231	0.5	1000

3.3.2 Measuring Instruments

Refer a test equipment and calibration data table in this test report.

3.3.3 Test Procedures

Test Method – General Information	
<input checked="" type="checkbox"/>	For the transmitter unwanted emissions shall be measured using following options below:
<input checked="" type="checkbox"/>	Refer as ANSI C63.10, clause 6.3 for unwanted emissions into non-restricted bands.
<input checked="" type="checkbox"/>	For unwanted emissions below 40GHz bands.
<input checked="" type="checkbox"/>	Radiated emissions below 40 GHz shall not exceed the general limits in LP0002 Section 2.8
<input checked="" type="checkbox"/>	Refer as ANSI C63.10, clause 4.1.4.2.3 (Video Averaging) average measurements using spectrum reduced video bandwidth (VBW≥10Hz) - [duty cycle ≥ 98 or external power trigger].
<input type="checkbox"/>	Refer as ANSI C63.10, clause 4.1.4.2.4 average value of pulsed emissions.
<input type="checkbox"/>	Refer as ANSI C63.10, clause 4.1.4.2.2 measurement procedure peak limit.

Test Method	
<input checked="" type="checkbox"/>	For radiated measurement below 40GHz.
<input checked="" type="checkbox"/>	Refer as ANSI C63.10, clause 6.3 through 6.6 for radiated emissions from below 40 GHz.
<input checked="" type="checkbox"/>	For radiated measurement above 40GHz. Refer as ANSI C63.10, clause 9.12 for radiated measurement.
<input checked="" type="checkbox"/>	Radiated test was conducted at far-field distance. the distance from the radiating element of the

Test Method	
	<p>EUT to the edge of the far field may be calculated from $[r \geq 2D^2/\lambda]$ r is the distance from the radiating element of the EUT to the edge of the far field, in m D is the largest dimension of both the radiating element and the test antenna (horn), in m λ is the wavelength of the emission under investigation $[300/f \text{ (MHz)}]$, in m</p>
<input checked="" type="checkbox"/>	<p>The measured power level is converted to EIRP using the Friis equation: $E \text{ Meas} = 126.8 - 20\log(\lambda) + P - G$</p> <p>where E is the field strength of the emission at the measurement distance, in $\text{dB}\mu\text{V/m}$ P is the power measured at the output of the test antenna, in dBm λ is the wavelength of the emission under investigation $[300/f\text{MHz}]$, in m G is the gain of the test antenna, in dBi</p> <hr/> <p>$EIRP = E \text{ Meas} + 20 \log(d \text{ Meas}) - 104.7$</p> <p>where $EIRP$: is the equivalent isotropically radiated power, in dBm. $E \text{ Meas}$: is the field strength of the emission at the measurement distance, in $\text{dB}\mu\text{V/m}$. $d \text{ Meas}$: is the measurement distance, in m.</p> <hr/> <p>Equations to calculate power density Calculate the power density at the distance specified by the limit from the EIRP in watts using Equation:</p> $PD = \frac{EIRP_{Linear}}{4\pi d^2}$ <p>where PD is the power density at the distance specified by the limit, in W/m^2 $EIRP_{Linear}$ is the equivalent isotropically radiated power, in watts d is the distance at which the power density limit is specified, in m.</p>

3.3.4 Test Setup

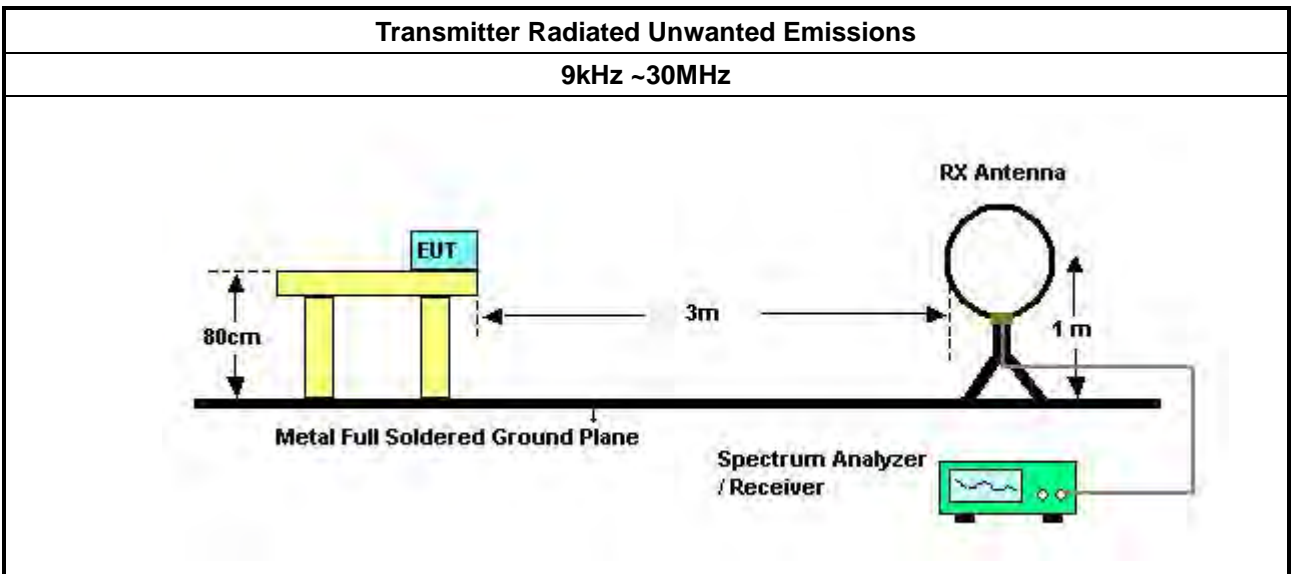

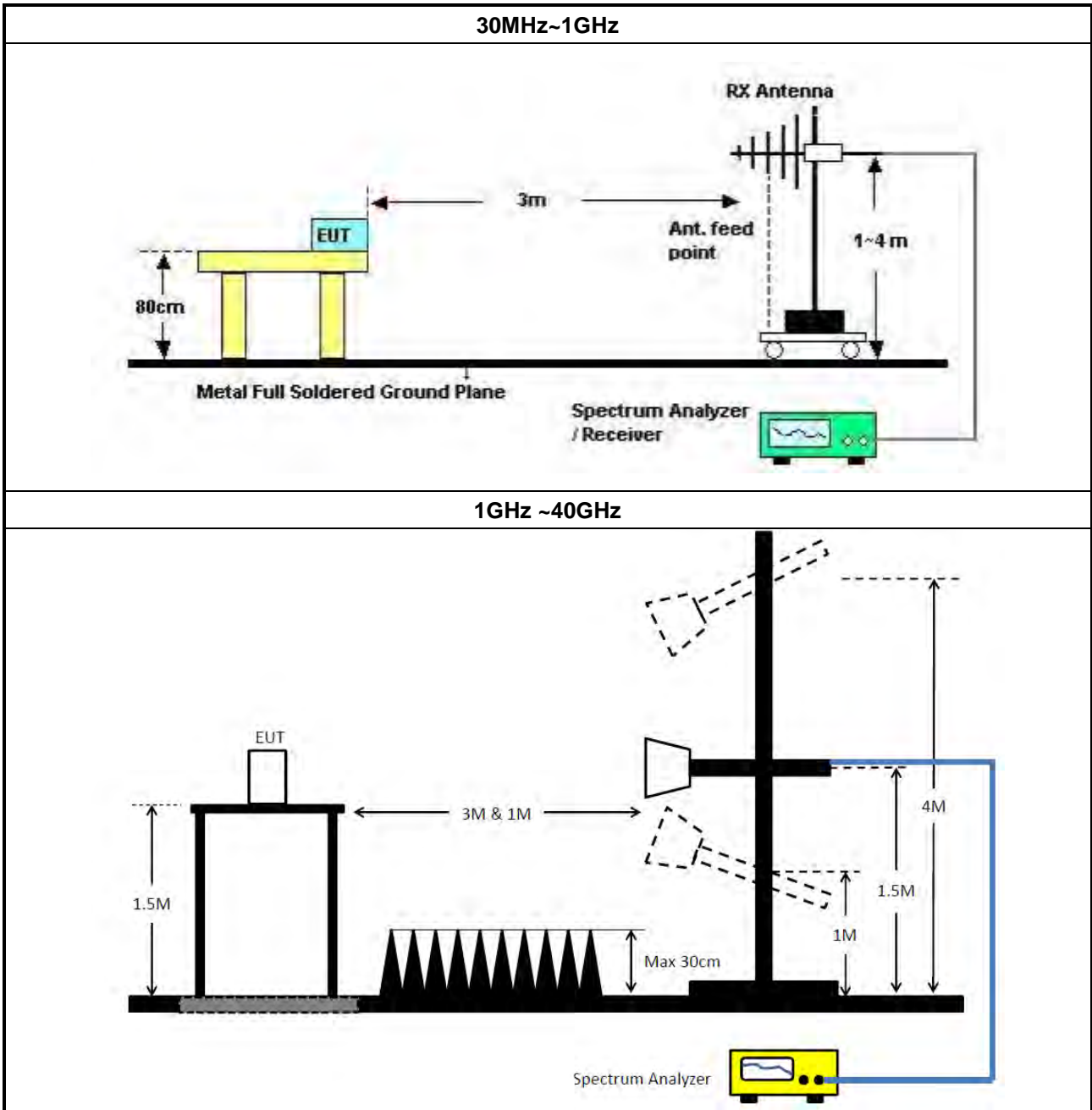

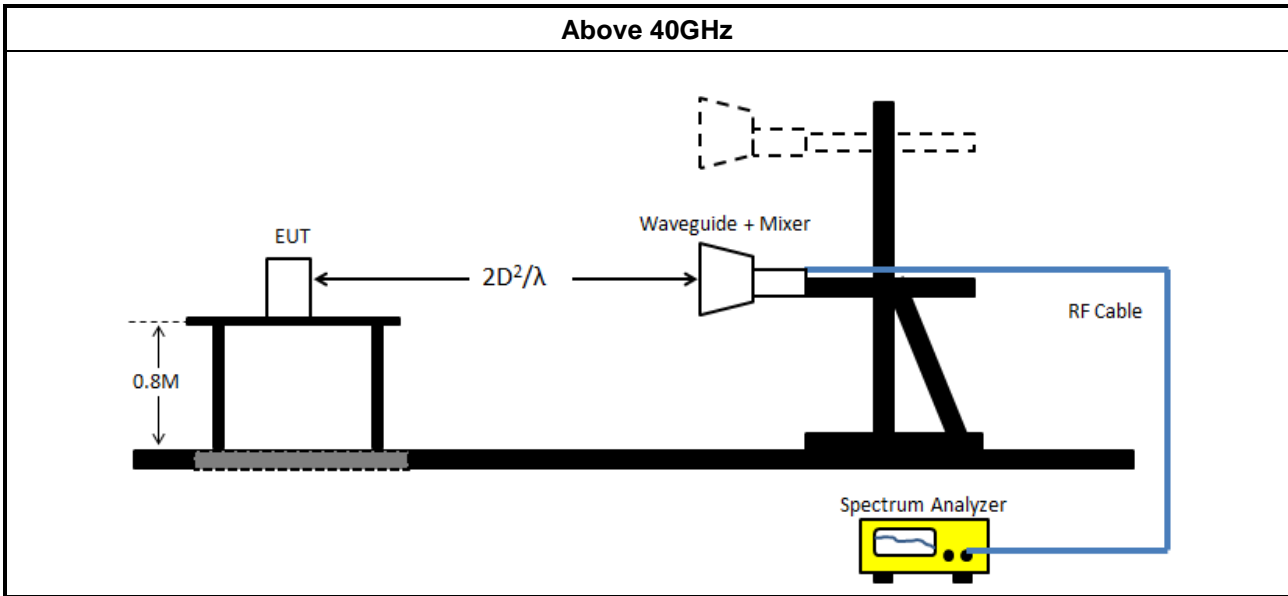

3.3.5 Measurement Results Calculation

The measured Level is calculated using:

For below 40GHz

Corrected Reading: Antenna factor (AF) + Cable loss (CL) + Read level (Raw) - Preamp factor (PA)(if applicable) = Level.

For above 40GHz

$EIRP = Read\ Level - Rx\ Gain + 20 * LOG(4 * 3.14159 * Distance / (300 / (Test\ Freq. * 1000)))$.

$Power\ Density = ((10^{(EIRP/10)} / 1000) / (4 * 3.14159 * (Specification\ Distance * 100)^2)) * 1000000000000$.

3.3.6 Test Result of Transmitter Radiated Unwanted Emissions (Below 30MHz)

There is a comparison data of both open-field test site and alternative test site - semi-Anechoic chamber according to KDB414788 Radiated Test Site, and the result came out very similar.

All amplitude of spurious emissions that are attenuated by more than 20 dB below the permissible value has no need to be reported.

The radiated emissions were investigated from 9 kHz or the lowest frequency generated within the device, up to the 10 harmonic or 40 GHz, whichever is appropriate.



3.3.7 Test Result of Transmitter Radiated Unwanted Emissions (30MHz ~ 1GHz)

Test Range	30 MHz – 1 GHz
-------------------	----------------

Vertical

Mode 4

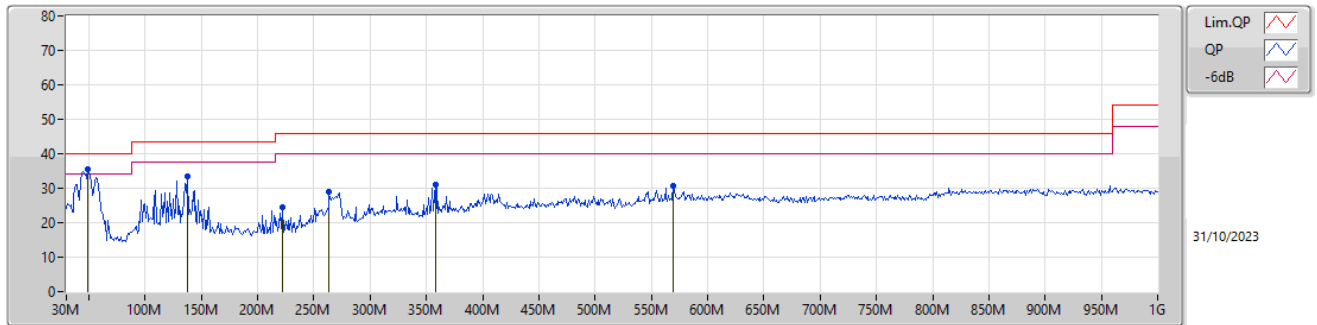

Type	Freq (Hz)	Level (dBuV/m)	Limit (dBuV/m)	Margin (dB)	Factor (dB/m)	Dist (m)	Condition	Azimuth (°)	Height (m)	Comment	Raw (dBuV/m)	AF (dB/m)	CL (dB)	PA (dB)
PK	49.4M	35.50	40.00	-4.50	-16.86	3	Vertical	299	1.00	"Worst"	52.36	14.16	0.53	31.55
PK	137.67M	33.58	43.50	-9.92	-12.74	3	Vertical	6	1.25	-	46.32	18.00	1.07	31.81
PK	222.06M	24.32	46.00	-21.68	-14.95	3	Vertical	130	1.00	-	39.27	15.49	1.35	31.79
PK	263.77M	28.80	46.00	-17.20	-11.26	3	Vertical	164	2.00	-	40.06	19.03	1.52	31.81
PK	357.86M	31.04	46.00	-14.96	-9.50	3	Vertical	3	2.00	-	40.54	20.51	1.81	31.82
PK	569.32M	30.62	46.00	-15.38	-5.20	3	Vertical	31	2.90	-	35.82	24.58	2.36	32.14

Horizontal

Mode 4

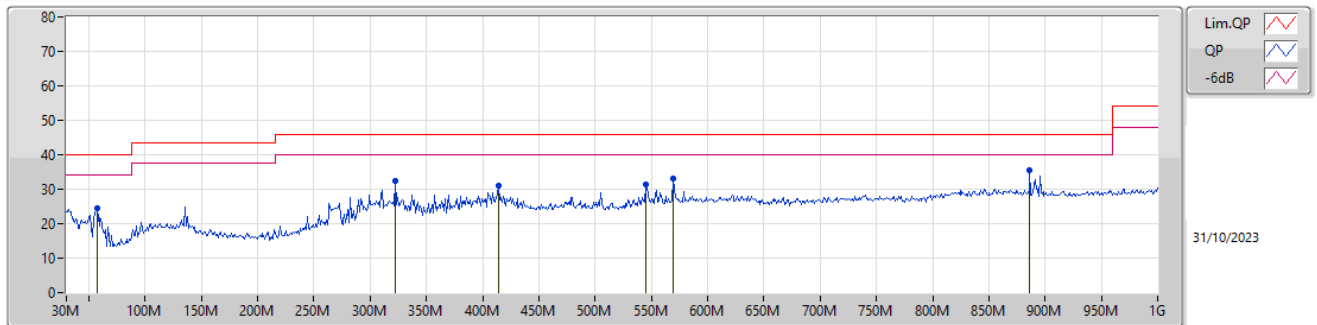

Type	Freq (Hz)	Level (dBuV/m)	Limit (dBuV/m)	Margin (dB)	Factor (dB/m)	Dist (m)	Condition	Azimuth (°)	Height (m)	Comment	Raw (dBuV/m)	AF (dB/m)	CL (dB)	PA (dB)
PK	57.16M	24.43	40.00	-15.57	-18.25	3	Horizontal	334	3.00	-	42.68	12.89	0.57	31.71
PK	321.97M	32.33	46.00	-13.67	-10.66	3	Horizontal	154	1.00	-	42.99	19.44	1.72	31.82
PK	414.12M	31.08	46.00	-14.92	-7.74	3	Horizontal	115	1.00	-	38.82	22.27	2.00	32.01
PK	545.07M	31.39	46.00	-14.61	-4.95	3	Horizontal	225	2.00	-	36.34	24.87	2.31	32.13
PK	569.32M	33.19	46.00	-12.81	-5.20	3	Horizontal	3	1.00	-	38.39	24.58	2.36	32.14
PK	886.51M	35.62	46.00	-10.38	-2.70	3	Horizontal	95	1.00	"Worst"	38.32	26.50	3.03	32.23

Note 1: ">20dB" means spurious emission levels that exceed the level of 20 dB below the applicable limit.

Note 2: "N/F" means Nothing Found spurious emissions (No spurious emissions were detected.)



3.3.8 Test Result of Transmitter Radiated Unwanted Emissions (1GHz – 40GHz)

Test Range	1 GHz – 18 GHz
-------------------	----------------

Vertical

Mode 1

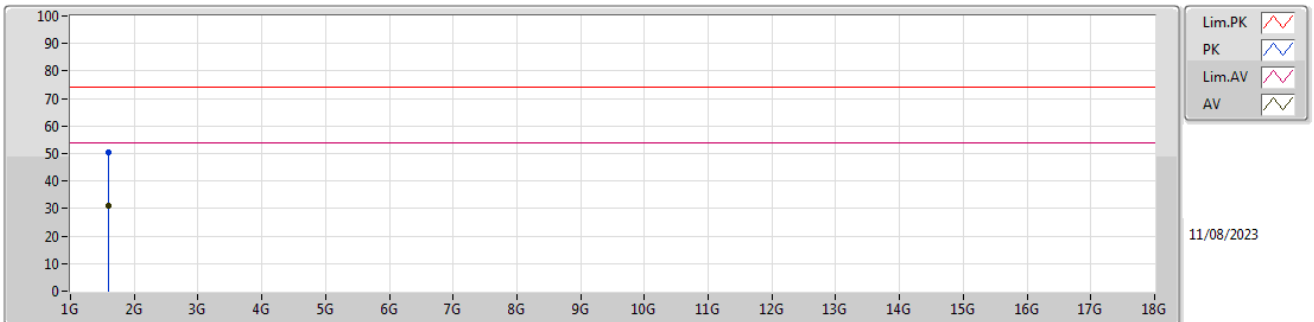

11/08/2023

EUT Y_1TX
Setting Default
03-I-W-4

Type	Freq (Hz)	Level (dBuV/m)	Limit (dBuV/m)	Margin (dB)	Factor (dB/m)	Dist (m)	Condition	Azimuth (°)	Height (m)	Comment	Raw (dBuV/m)	AF (dB/m)	CL (dB)	PA (dB)
PK	1.59855G	50.51	74.00	-23.49	-5.43	3	Vertical	212	2.30	-	55.94	25.49	3.70	34.62
AV	1.59715G	30.91	54.00	-23.09	-5.45	3	Vertical	212	2.30	"Worst"	36.36	25.47	3.70	34.62



Horizontal

Mode 1

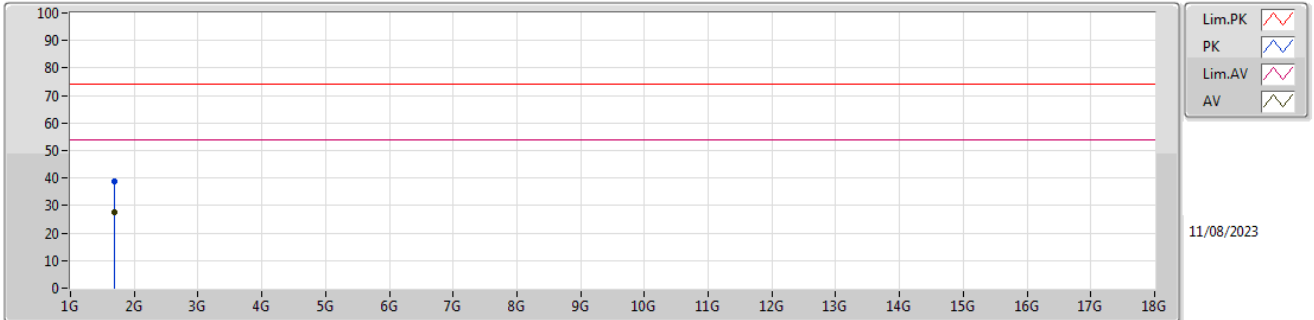

EUT Y_1TX
Setting Default
03-I-W-4

Type	Freq (Hz)	Level (dBuV/m)	Limit (dBuV/m)	Margin (dB)	Factor (dB/m)	Dist (m)	Condition	Azimuth (°)	Height (m)	Comment	Raw (dBuV/m)	AF (dB/m)	CL (dB)	PA (dB)
PK	1.69675G	38.59	74.00	-35.41	-4.58	3	Horizontal	45	2.47	-	43.17	26.27	3.80	34.65
AV	1.6948G	27.41	54.00	-26.59	-4.59	3	Horizontal	45	2.47	"Worst"	32.00	26.26	3.79	34.64



Test Range	18 GHz – 40 GHz
-------------------	-----------------

Vertical

Mode 1

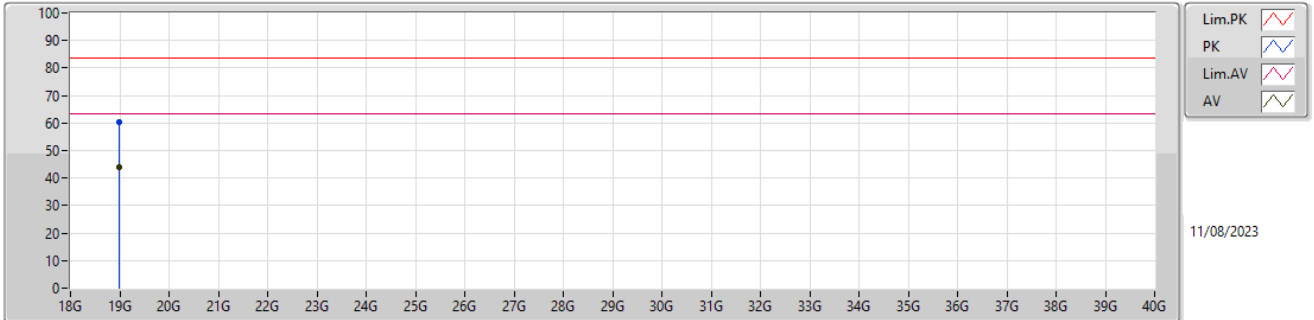

EUTY_1TX
Setting Default
03-I-W-4

Type	Freq (Hz)	Level (dBuV/m)	Limit (dBuV/m)	Margin (dB)	Factor (dB/m)	Dist (m)	Condition	Azimuth (°)	Height (m)	Comment	Raw (dBuV/m)	AF (dB/m)	CL (dB)	PA (dB)
PK	18.98225G	60.51	83.54	-23.03	3.85	1	Vertical	-0	1.50	-	56.66	37.79	16.84	50.78
AV	18.98022G	43.95	63.54	-19.59	3.85	1	Vertical	-0	1.50	"Worst"	40.10	37.79	16.84	50.78



Horizontal

Mode 1

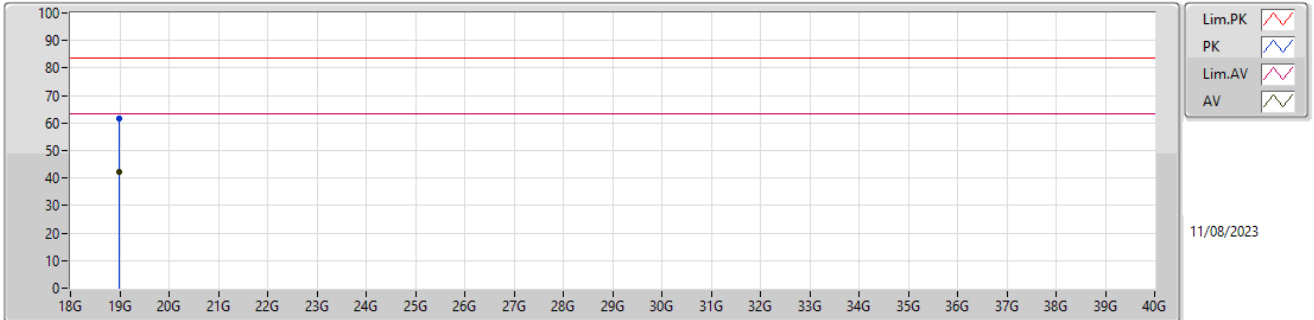

EUT Y_1TX
Setting Default
03-I-W-4

Type	Freq (Hz)	Level (dBuV/m)	Limit (dBuV/m)	Margin (dB)	Factor (dB/m)	Dist (m)	Condition	Azimuth (°)	Height (m)	Comment	Raw (dBuV/m)	AF (dB/m)	CL (dB)	PA (dB)
PK	18.99115G	61.58	83.54	-21.96	3.86	1	Horizontal	104	1.50	-	57.72	37.80	16.85	50.79
AV	18.99155G	42.29	63.54	-21.25	3.86	1	Horizontal	104	1.50	"Worst"	38.43	37.80	16.85	50.79

Note 1: ">20dB" means spurious emission levels that exceed the level of 20 dB below the applicable limit.
 Note 2: "N/F" means Nothing Found spurious emissions (No spurious emissions were detected.)



3.3.9 Test Result of Transmitter Radiated Unwanted Emissions (40GHz – 200GHz)

Test Freq. (GHz)	Rx Gain (dBi)	Distance (m)	Read Worse Frequency (GHz)	Read Level (dBm)	EIRP (dBm)	Specification Distance (m)	Power Density (pW/cm ²)	Test Result
76.2315	23.2	0.50	61.35	-84	-45.02	3	0.0278	PASS
Limit							600	-

3.3.10 Test Result of Transmitter Radiated Unwanted Emissions (200GHz – 231GHz)

Test Freq. (GHz)	Rx Gain (dBi)	Distance (m)	Read Worse Frequency (GHz)	Read Level (dBm)	EIRP (dBm)	Specification Distance (m)	Power Density (pW/cm ²)	Test Result
76.2315	24.2	0.50	219.36	-99.21	-50.17	3	0.0085	PASS
Limit							1000	-

3.4 Frequency Stability

3.4.1 Frequency Stability Limit

Frequency Stability Limit
Fundamental emissions must be contained within the frequency bands specified in this 76-81GHz band during all conditions of operation. Equipment is presumed to operate over the temperature range -20 to +50 degrees Celsius with an input voltage variation of 85% to 115% of rated input voltage.

3.4.2 Measuring Instruments

Refer a test equipment and calibration data table in this test report.

3.4.3 Test Procedures

Test Method	
<input checked="" type="checkbox"/>	For the frequency stability shall be measured using one of the options below:
<input checked="" type="checkbox"/>	Refer as ANSI C63.10, clause 9.14 for frequency stability measurement.
<input checked="" type="checkbox"/>	Refer as ANSI C63.10, clause 9 for radiated measurement.
<input checked="" type="checkbox"/>	Radiated test was conducted at far-field distance. the distance from the radiating element of the EUT to the edge of the far field may be calculated from $[r \geq 2D^2/\lambda]$ r is the distance from the radiating element of the EUT to the edge of the far field, in m D is the largest dimension of both the radiating element and the test antenna (horn), in m λ is the wavelength of the emission under investigation $[300/f \text{ (MHz)}]$, in m
<input checked="" type="checkbox"/>	The mixer may be placed outside the chamber in front of the temperature chamber door, and the chamber door opened for each reading.

3.4.4 Test Setup

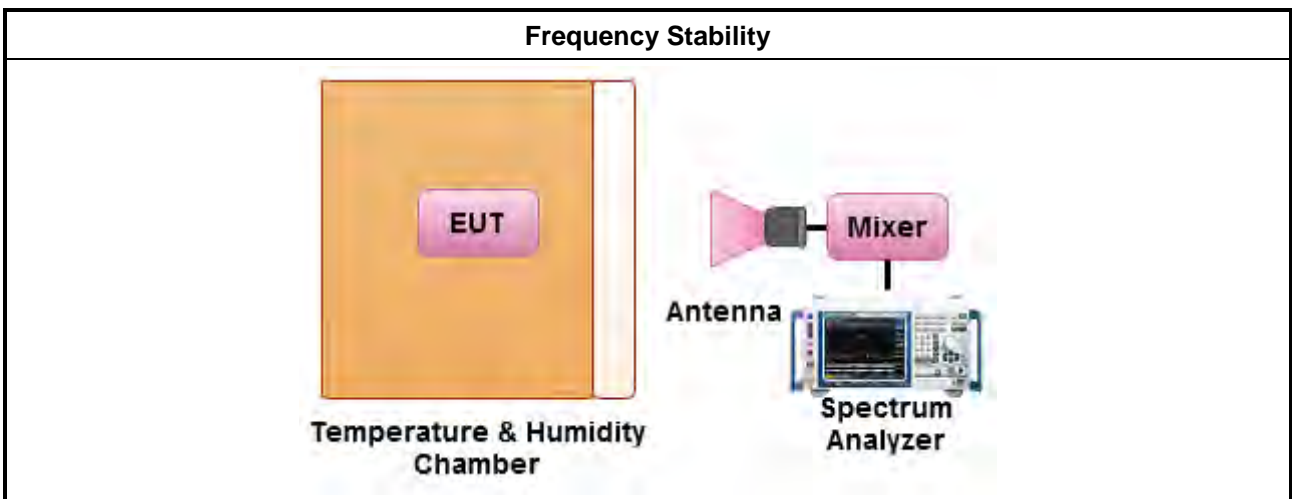



3.4.5 Test Result of Frequency Stability

Test Freq. (GHz): 76.2315

Test Temperature: (°C)	Measured Frequency (MHz)	Delta Frequency (kHz)	Limit (±kHz)
-20	76238.254	166	Within band
-10	76238.463	374	Within band
0	76238.538	450	Within band
10	76238.591	503	Within band
20	76238.089	Reference	Within band
30	76238.207	118	Within band
40	76238.387	298	Within band
50	76238.422	215	Within band
Test Voltage: (Vdc)	Measured Frequency (MHz)	Delta Frequency (kHz)	Limit (±kHz)
4.25	76238.581	493	Within band
5	76238.089	Reference	Within band
5.75	76238.204	115	Within band



4 Test Equipment and Calibration Data

Instrument	Brand	Model No.	Serial No.	Characteristics	Calibration Date	Calibration Due Date	Remark
Loop Antenna	Teseq	HLA 6120	31244	9kHz - 30 MHz	Mar. 23, 2023	Mar. 22, 2024	Radiation (03CH04-CB)
3m Semi Anechoic Chamber NSA	TDK	SAC-3M	03CH04-CB	30 MHz ~ 1 GHz	Aug. 01, 2023	Jul. 31, 2024	Radiation (03CH04-CB)
BILOG ANTENNA with 6 dB attenuator	Schaffner & EMC	CBL6112B & N-6-06	22021&AT-N0607	30MHz ~ 1GHz	Oct. 08, 2022	Oct. 07, 2023	Radiation (03CH04-CB)
BILOG ANTENNA with 6 dB attenuator	Schaffner & EMC	CBL6112B & N-6-06	22021&AT-N0607	30MHz ~ 1GHz	Oct. 07, 2023	Oct. 06, 2024	Radiation (03CH04-CB)
Pre-Amplifier	EMCI	EMC330N	980391	20MHz ~ 3GHz	May 23, 2023	May 22, 2024	Radiation (03CH04-CB)
Spectrum Analyzer	R&S	FSP40	100142	9kHz~40GHz	Mar. 21, 2023	Mar. 20, 2024	Radiation (03CH04-CB)
EMI Test Receiver	R&S	ESCS	826547/017	9kHz ~ 2.75GHz	Jun. 13, 2023	Jun. 12, 2024	Radiation (03CH04-CB)
RF Cable-low	Woken	RG402	Low Cable-03+67	30MHz ~ 1GHz	Oct. 03, 2022	Oct. 02, 2023	Radiation (03CH04-CB)
RF Cable-low	Woken	RG402	Low Cable-03+67	30MHz ~ 1GHz	Oct. 02, 2023	Oct. 01, 2024	Radiation (03CH04-CB)
Test Software	SPORTON	SENSE	V5.10	-	N.C.R.	N.C.R.	Radiation (03CH04-CB)
3m Semi Anechoic Chamber VSWR	TDK	SAC-3M	03CH01-CB	1GHz ~18GHz 3m	May 05, 2023	May 04, 2024	Radiation (03CH01-CB)
Horn Antenna	ETS-LINDGREN	3115	00075790	750MHz ~ 18GHz	Nov. 04, 2022	Nov. 03, 2023	Radiation (03CH01-CB)
Horn Antenna	SCHWARZBECK	BBHA 9170	BBHA9170507	15GHz ~ 40GHz	Jun. 28, 2023	Jun. 27, 2024	Radiation (03CH01-CB)
Pre-Amplifier	Agilent	8449B	3008A02121	1GHz ~ 26.5GHz	May 18, 2023	May 17, 2024	Radiation (03CH01-CB)
Pre-Amplifier	SGH	SGH184	20221107-3	18GHz ~ 40GHz	Nov. 16, 2022	Nov. 15, 2023	Radiation (03CH01-CB)
Signal Analyzer	R&S	FSV3044	101437	10kHz ~ 44GHz	Nov. 29, 2022	Nov. 29, 2023	Radiation (03CH01-CB)
RF Cable-high	Woken	RG402	High Cable-16	1 GHz ~ 18 GHz	Oct. 03, 2022	Oct. 02, 2023	Radiation (03CH01-CB)
RF Cable-high	Woken	RG402	High Cable-16	1 GHz ~ 18 GHz	Oct. 02, 2023	Oct. 01, 2024	Radiation (03CH01-CB)
RF Cable-high	Woken	RG402	High Cable-16+17	1 GHz ~ 18 GHz	Oct. 03, 2022	Oct. 02, 2023	Radiation (03CH01-CB)



Instrument	Brand	Model No.	Serial No.	Characteristics	Calibration Date	Calibration Due Date	Remark
RF Cable-high	Woken	RG402	High Cable-16+17	1 GHz ~ 18 GHz	Oct. 02, 2023	Oct. 01, 2024	Radiation (03CH01-CB)
High Cable	Woken	WCA0929M	40G#5+6	1GHz ~ 40 GHz	Dec. 07, 2022	Dec. 06, 2023	Radiation (03CH01-CB)
High Cable	Woken	WCA0929M	40G#5	1GHz ~ 40 GHz	Dec. 07, 2022	Dec. 06, 2023	Radiation (03CH01-CB)
High Cable	Woken	WCA0929M	40G#6	1GHz ~ 40 GHz	Dec. 07, 2022	Dec. 06, 2023	Radiation (03CH01-CB)
Test Software	SPORTON	SENSE	V5.10	-	N.C.R.	N.C.R.	Radiation (03CH01-CB)
*Mixer	OML	M19HWA	U91113-1	40 ~ 60 GHz	Mar. 10, 2022	Mar. 09, 2024	Radiation (03CH01-CB)
*Mixer	OML	M15HWA	V91113-1	50 ~ 75 GHz	Oct. 22, 2022	Oct. 21, 2024	Radiation (03CH01-CB)
*Mixer	OML	M12HWA	E91113-1	60 ~ 90 GHz	Oct. 22, 2022	Oct. 21, 2024	Radiation (03CH01-CB)
*Mixer	OML	M08HWA	F91113-1	90 ~ 140 GHz	Mar. 10, 2022	Mar. 09, 2024	Radiation (03CH01-CB)
*Mixer	OML	M05HW/A	G91113-1	140 ~ 220 GHz	Mar. 10, 2022	Mar. 09, 2024	Radiation (03CH01-CB)
*Mixer	OML	M03HWD	120320-1	220 ~ 325 GHz	Mar. 10, 2022	Mar. 09, 2024	Radiation (03CH01-CB)
Standard Horn Antenna	Custom Microwave	M19RH	U91113-A	40 ~ 60 GHz	N.C.R.	N.C.R.	Radiation (03CH01-CB)
Standard Horn Antenna	Custom Microwave	M15RH	V91113-A	50 ~ 75 GHz	N.C.R.	N.C.R.	Radiation (03CH01-CB)
Standard Horn Antenna	Custom Microwave	M12RH	E91113-A	60 ~ 90 GHz	N.C.R.	N.C.R.	Radiation (03CH01-CB)
Standard Horn Antenna	Custom Microwave	M08RH	F91113-A	90 ~ 140 GHz	N.C.R.	N.C.R.	Radiation (03CH01-CB)
Standard Horn Antenna	Custom Microwave	M05RH	G91113-A	140 ~ 220 GHz	N.C.R.	N.C.R.	Radiation (03CH01-CB)
Standard Horn Antenna	Custom Microwave	M03RH	120320-A	220 ~ 325 GHz	N.C.R.	N.C.R.	Radiation (03CH01-CB)
3m Semi Anechoic Chamber VSWR	TDK	SAC-3M	03CH03-CB	1GHz ~18GHz 3m	May 04, 2023	May 03, 2024	Radiation (03CH03-CB)
Horn Antenna	ETS · Lindgren	3115	6821	750MHz~18GHz	Feb. 03, 2023	Feb. 02, 2024	Radiation (03CH03-CB)
Horn Antenna	SCHWARZBECK	BBHA 9170	BBHA9170507	15GHz ~ 40GHz	Jun. 28, 2023	Jun. 27, 2024	Radiation (03CH03-CB)
Pre-Amplifier	Agilent	8449B	3008A02097	1GHz ~ 26.5GHz	Jun. 30, 2023	Jun. 29, 2024	Radiation (03CH03-CB)
Pre-Amplifier	SGH	SGH184	20221107-3	18GHz ~ 40GHz	Nov. 16, 2022	Nov. 15, 2023	Radiation (03CH03-CB)



Instrument	Brand	Model No.	Serial No.	Characteristics	Calibration Date	Calibration Due Date	Remark
Spectrum Analyzer	R&S	FSP40	100019	9kHz ~ 40GHz	Jun. 12, 2023	Jun. 11, 2024	Radiation (03CH03-CB)
RF Cable-high	Woken	RG402	High Cable-20+29	1GHz ~ 18GHz	Oct. 03, 2022	Oct. 02, 2023	Radiation (03CH03-CB)
RF Cable-high	Woken	RG402	High Cable-20+29	1GHz ~ 18GHz	Oct. 02, 2023	Oct. 01, 2024	Radiation (03CH03-CB)
RF Cable-high	Woken	RG402	High Cable-29	1GHz ~ 18GHz	Oct. 03, 2022	Oct. 02, 2023	Radiation (03CH03-CB)
RF Cable-high	Woken	RG402	High Cable-29	1GHz ~ 18GHz	Oct. 02, 2023	Oct. 01, 2024	Radiation (03CH03-CB)
High Cable	Woken	WCA0929M	40G#5+6	1GHz ~ 40 GHz	Dec. 07, 2022	Dec. 06, 2023	Radiation (03CH03-CB)
High Cable	Woken	WCA0929M	40G#5	1GHz ~ 40 GHz	Dec. 07, 2022	Dec. 06, 2023	Radiation (03CH03-CB)
High Cable	Woken	WCA0929M	40G#6	1GHz ~ 40 GHz	Dec. 07, 2022	Dec. 06, 2023	Radiation (03CH03-CB)
Test Software	SPORTON	SENSE	V5.10	-	N.C.R.	N.C.R.	Radiation (03CH03-CB)
*Mixer	OML	M19HWA	U91113-1	40 ~ 60 GHz	Mar. 10, 2022	Mar. 09, 2024	Radiation (03CH03-CB)
*Mixer	OML	M15HWA	V91113-1	50 ~ 75 GHz	Oct. 22, 2022	Oct. 21, 2024	Radiation (03CH03-CB)
*Mixer	OML	M12HWA	E91113-1	60 ~ 90 GHz	Oct. 22, 2022	Oct. 21, 2024	Radiation (03CH03-CB)
*Mixer	OML	M08HWA	F91113-1	90 ~ 140 GHz	Mar. 10, 2022	Mar. 09, 2024	Radiation (03CH03-CB)
*Mixer	OML	M05HW/A	G91113-1	140 ~ 220 GHz	Mar. 10, 2022	Mar. 09, 2024	Radiation (03CH03-CB)
*Mixer	OML	M03HWD	120320-1	220 ~ 325 GHz	Mar. 10, 2022	Mar. 09, 2024	Radiation (03CH03-CB)
Standard Horn Antenna	Custom Microwave	M19RH	U91113-A	40 ~ 60 GHz	N.C.R	N.C.R	Radiation (03CH03-CB)
Standard Horn Antenna	Custom Microwave	M15RH	V91113-A	50 ~ 75 GHz	N.C.R	N.C.R	Radiation (03CH03-CB)
Standard Horn Antenna	Custom Microwave	M12RH	E91113-A	60 ~ 90 GHz	N.C.R	N.C.R	Radiation (03CH03-CB)
Standard Horn Antenna	Custom Microwave	M08RH	F91113-A	90 ~ 140 GHz	N.C.R	N.C.R	Radiation (03CH03-CB)
Standard Horn Antenna	Custom Microwave	M05RH	G91113-A	140 ~ 220 GHz	N.C.R	N.C.R	Radiation (03CH03-CB)
Standard Horn Antenna	Custom Microwave	M03RH	120320-A	220 ~ 325 GHz	N.C.R	N.C.R	Radiation (03CH03-CB)
Spectrum analyzer	R&S	FSV40	101028	9kHz~40GHz	Dec. 30, 2022	Dec. 29, 2023	Radiation (TH03-CB)



Instrument	Brand	Model No.	Serial No.	Characteristics	Calibration Date	Calibration Due Date	Remark
Temp. and Humidity Chamber	Gaint Force	GTH-408-40-C P-AR	MAA1410-011	-40~100 degree	Sep. 02, 2022	Sep. 01, 2023	Radiation (TH03-CB)
RF Cable	Woken	RG402	High Cable-11	30MHz ~18 GHz	Feb. 14, 2023	Feb. 13, 2024	Radiation (TH03-CB)
RF Cable	Woken	RG402	High Cable-12	30MHz ~18 GHz	Feb. 14, 2023	Feb. 13, 2024	Radiation (TH03-CB)
RF Cable	Woken	RG402	High Cable-13	30MHz ~18 GHz	Feb. 14, 2023	Feb. 13, 2024	Radiation (TH03-CB)
RF Cable-high	Woken	RG402	High Cable-14	1 GHz ~18 GHz	Oct. 03, 2022	Oct. 02, 2023	Radiation (TH03-CB)
RF Cable-high	Woken	RG402	High Cable-15	1 GHz ~18 GHz	Oct. 03, 2022	Oct. 02, 2023	Radiation (TH03-CB)

Note: Calibration Interval of instruments listed above is one year.

“*” Calibration Interval of instruments listed above is two years.

N.C.R. means Non-Calibration required.