



RADIO TEST REPORT

FCC ID : 2AHXD-5313794
Equipment : CarBack Radar
Brand Name : TREK
Model Name : 5313794
Applicant : Trek Bicycle Corporation
801 W Madison St, Waterloo, WI 53594
Manufacturer : Universal Microelectronics co.,LTD
3,27TH RD.,Taichung Industrial Park.Taichung, Taiwan
Standard : 47 CFR FCC Part 15.247

The product was received on Jun. 19, 2023, and testing was started from Aug. 11, 2023 and completed on Nov. 06, 2023. We, Sporton International Inc. Hsinchu Laboratory, would like to declare that the tested sample has been evaluated in accordance with the procedures given in ANSI C63.10-2013 and shown compliance with the applicable technical standards.

The test results in this report apply exclusively to the tested model / sample. Without written approval of Sporton International Inc. Hsinchu Laboratory, the test report shall not be reproduced except in full.

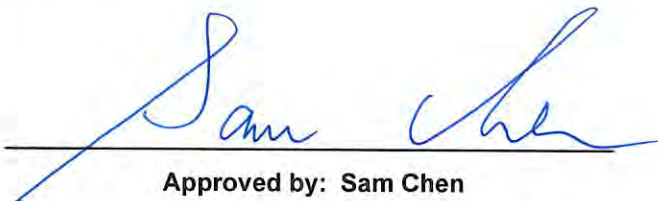

Approved by: Sam Chen

Sporton International Inc. Hsinchu Laboratory
No.8, Ln. 724, Bo'ai St., Zhubei City, Hsinchu County 302010, Taiwan (R.O.C.)



Table of Contents

History of this test report.....3

Summary of Test Result.....4

1 General Description5

1.1 Information.....5

1.2 Applicable Standards7

1.3 Testing Location Information7

1.4 Measurement Uncertainty7

2 Test Configuration of EUT8

2.1 Test Channel Mode8

2.2 The Worst Case Measurement Configuration8

2.3 EUT Operation during Test9

2.4 Accessories9

2.5 Support Equipment.....10

2.6 Test Setup Diagram11

3 Transmitter Test Result14

3.1 AC Power-line Conducted Emissions14

3.2 DTS Bandwidth.....16

3.3 Maximum Conducted Output Power17

3.4 Power Spectral Density20

3.5 Emissions in Non-restricted Frequency Bands22

3.6 Emissions in Restricted Frequency Bands.....23

4 Test Equipment and Calibration Data27

Appendix A. Test Results of AC Power-line Conducted Emissions

Appendix B. Test Results of DTS Bandwidth

Appendix C. Test Results of Maximum Conducted Output Power

Appendix D. Test Results of Power Spectral Density

Appendix E. Test Results of Emissions in Non-restricted Frequency Bands

Appendix F. Test Results of Emissions in Restricted Frequency Bands

Appendix G. Test Photos

Photographs of EUT v01



Summary of Test Result

Report Clause	Ref Std. Clause	Test Items	Result (PASS/FAIL)	Remark
1.1.2	15.203	Antenna Requirement	PASS	-
3.1	15.207	AC Power-line Conducted Emissions	PASS	-
3.2	15.247(a)	DTS Bandwidth	PASS	-
3.3	15.247(b)	Maximum Conducted Output Power	PASS	-
3.4	15.247(e)	Power Spectral Density	PASS	-
3.5	15.247(d)	Emissions in Non-restricted Frequency Bands	PASS	-
3.6	15.247(d)	Emissions in Restricted Frequency Bands	PASS	-

Note: Reference to Sporton Project No.: 360116

Conformity Assessment Condition:

1. The test results (PASS/FAIL) with all measurement uncertainty excluded are presented against the regulation limits or in accordance with the requirements stipulated by the applicant/manufacturer who shall bear all the risks of non-compliance that may potentially occur if measurement uncertainty is taken into account.
2. The measurement uncertainty please refer to each test result in the chapter "Measurement Uncertainty".

Disclaimer:

The product specifications of the EUT presented in the test report that may affect the test assessments are declared by the manufacturer who shall take full responsibility for the authenticity.

Reviewed by: Sam Chen

Report Producer: Sandy Chuang



1 General Description

1.1 Information

1.1.1 RF General Information

Frequency Range (MHz)	Mode	Ch. Frequency (MHz)	Channel Number
2400-2483.5	ANT plus	2457	57 [1]

Band	Mode	BWch (MHz)	Nant
2.4-2.4835GHz	GFSK	1	1TX

Note:

- ♦ ANT plus uses a GFSK modulation.
- ♦ BWch is the nominal channel bandwidth.

1.1.2 Antenna Information

Ant.	Port			Brand	Model Name	Antenna Type	Connector	Gain (dBi)
	Bluetooth / ANT plus	76~81GHz						
		TX	RX					
1	-	1~3	1~6	UMEC	S78*	Patch	N/A	11.2
2	1	-	-	JOHANSON	2450AT18D0100E	Chip	N/A	1.5

Note 1: The above information was declared by manufacturer.

Note 2: The Bluetooth and ANT plus cannot function at the same time.

Note 3: **For Bluetooth function (1TX/1RX):**

Only Port 1 can be used as transmitting/receiving antenna.

For ANT plus function (1TX/1RX):

Only Port 1 can be used as transmitting/receiving antenna.

For 76~81GHz function (3TX/6RX):

Port 1~3 can be used as transmitting antenna.

Port 1~3 could transmit simultaneously.

Port 1~6 can be used as receiving antenna.

Port 1~6 could receive simultaneously.



1.1.3 Mode Test Duty Cycle

Mode	DC	DCF(dB)	T(s)	VBW(Hz) ≥ 1/T
GFSK	0.819	0.87	535u	3k

Note:

- ◆ DC is Duty Cycle.
- ◆ DCF is Duty Cycle Factor.

1.1.4 EUT Operational Condition

EUT Power Type	From Battery or Host system		
Function	<input checked="" type="checkbox"/> Point-to-multipoint	<input type="checkbox"/>	Point-to-point
Test Software Version	Software Version 13.75		

Note: The above information was declared by manufacturer.



1.2 Applicable Standards

According to the specifications of the manufacturer, the EUT must comply with the requirements of the following standards:

- ♦ 47 CFR FCC Part 15.247
- ♦ ANSI C63.10-2013

The following reference test guidance is not within the scope of accreditation of TAF.

- ♦ FCC KDB 558074 D01 v05r02
- ♦ FCC KDB 414788 D01 v01r01

1.3 Testing Location Information

Testing Location Information	
Test Lab. : Sporton International Inc. Hsinchu Laboratory	
Hsinchu (TAF: 3787)	ADD: No.8, Ln. 724, Bo'ai St., Zhubei City, Hsinchu County 302010, Taiwan (R.O.C.) TEL: 886-3-656-9065 FAX: 886-3-656-9085 Test site Designation No. TW3787 with FCC. Conformity Assessment Body Identifier (CABID) TW3787 with ISED.

Test Condition	Test Site No.	Test Engineer	Test Environment (°C / %)	Test Date
RF Conducted	TH01-CB	Eason chen	23.6~24.1 / 66~67	Aug. 18, 2023~ Oct. 13, 2023
Radiated < 1GHz	03CH04-CB	Gordon Hong	22.4~23.5 / 55~58	Aug. 11, 2023~ Nov. 01, 2023
Radiated > 1GHz	03CH05-CB	Chris Lee	22.4~23.9 / 59~60	Aug. 11, 2023~ Oct. 13, 2023
AC Conduction	CO02-CB	CO02-CB	22~23 / 50~51	Nov. 06, 2023

1.4 Measurement Uncertainty

ISO/IEC 17025 requires that an estimate of the measurement uncertainties associated with the emissions test results be included in the report. The measurement uncertainties given below are based on a 95% confidence level (based on a coverage factor (k=2))

Test Items	Uncertainty	Remark
Conducted Emission (150kHz ~ 30MHz)	3.4 dB	Confidence levels of 95%
Radiated Emission (9kHz ~ 30MHz)	3.7 dB	Confidence levels of 95%
Radiated Emission (30MHz ~ 1,000MHz)	5.1 dB	Confidence levels of 95%
Radiated Emission (1GHz ~ 18GHz)	4.1 dB	Confidence levels of 95%
Radiated Emission (18GHz ~ 40GHz)	4.2 dB	Confidence levels of 95%
Conducted Emission	3.1 dB	Confidence levels of 95%
Output Power Measurement	0.8 dB	Confidence levels of 95%
Power Density Measurement	3.1 dB	Confidence levels of 95%
Bandwidth Measurement	2.2%	Confidence levels of 95%



2 Test Configuration of EUT

2.1 Test Channel Mode

Mode	Power Setting
GFSK_1MHz_Nss1_1TX	-
2457MHz	-4

2.2 The Worst Case Measurement Configuration

The Worst Case Mode for Following Conformance Tests	
Tests Item	AC power-line conducted emissions
Condition	AC power-line conducted measurement for line and neutral Test Voltage: 120Vac / 60Hz
Operating Mode	Normal Link
1	EUT_76~81GHz + Bluetooth (Powered by Host system)
2	EUT_76~81GHz + Bluetooth (Powered by Adapter)
Mode 1 has been evaluated to be the worst case among Mode 1~2, so measurement for Mode 3 will follow this same test mode.	
3	EUT_76~81GHz + ANT plus (Powered by Host system)
For operating mode 3 is the worst case and it was record in this test report.	

The Worst Case Mode for Following Conformance Tests	
Tests Item	DTS Bandwidth Maximum Conducted Output Power Power Spectral Density Emissions in Non-restricted Frequency Bands
Test Condition	Conducted measurement at transmit chains

The Worst Case Mode for Following Conformance Tests	
Tests Item	Emissions in Restricted Frequency Bands
Test Condition	Radiated measurement If EUT consist of multiple antenna assembly (multiple antenna are used in EUT regardless of spatial multiplexing MIMO configuration), the radiated test should be performed with highest antenna gain of each antenna type.
Operating Mode < 1GHz	Normal link After evaluating, EUT in Y axis was the worst case, so the measurement will follow this same test configuration.
1	EUT in Y axis_76~81GHz + ANT plus (Powered by Host system)
2	EUT in Y axis_76~81GHz + ANT plus (Powered by Adapter)



3	EUT in Y axis_76~81GHz + ANT plus (Powered by Battery)
Mode 1 has been evaluated to be the worst case among Mode 1~3, thus measurement for Mode 4 will follow this same test mode.	
4	EUT in Y axis_76~81GHz + Bluetooth (Powered by Host system)
For operating, mode 4 is the worst case and it was record in this test report.	
Operating Mode > 1GHz	CTX
	After evaluating, EUT in Y axis was the worst case, so the measurement will follow this same test configuration.
1	EUT in Y axis

The Worst Case Mode for Following Conformance Tests	
Tests Item	Simultaneous Transmission Analysis - Co-location RF Exposure Evaluation
Operating Mode	
1	76~81GHz + Bluetooth
2	76~81GHz + ANT plus
Refer to Sporton Test Report No.: FA360116-03 for Co-location RF Exposure Evaluation.	

Note: The adapter was for measurement only and would not be marketed. Its information is shown as below:

Equipment	Brand Name	Model Name
Adapter	XIAOMI	MDY-09-EA

2.3 EUT Operation during Test

For CTX Mode:

The EUT was programmed to be in continuously transmitting mode.

For Normal Link Mode:

During the test, the EUT operation to normal function.

2.4 Accessories

Accessories
USB cable*1: Shielded, 1.5m
Lithium-ion battery*1



2.5 Support Equipment

For AC Conduction:

Support Equipment				
No.	Equipment	Brand Name	Model Name	FCC ID
A	NB	DELL	PP13S	N/A
B	Earphone	SHYARO CHI	MIC-04	N/A
C	Mouse	Logitech	M-U0026	N/A
D	Carplay	BONTRAGER	Garmin edge 1030	N/A

For Radiated < 1GHz:

Support Equipment				
No.	Equipment	Brand Name	Model Name	FCC ID
A	NB	DELL	E4300	N/A
B	Smart phone	Nokia	TA-1062	N/A
C	Earphone	SHYARO CHI	MIC-04	N/A
D	Mouse	Logitech	M-U0026	N/A

For Radiated > 1GHz and RF Conducted:

Support Equipment				
No.	Equipment	Brand Name	Model Name	FCC ID
A	Notebook	DELL	E4300	N/A

2.6 Test Setup Diagram

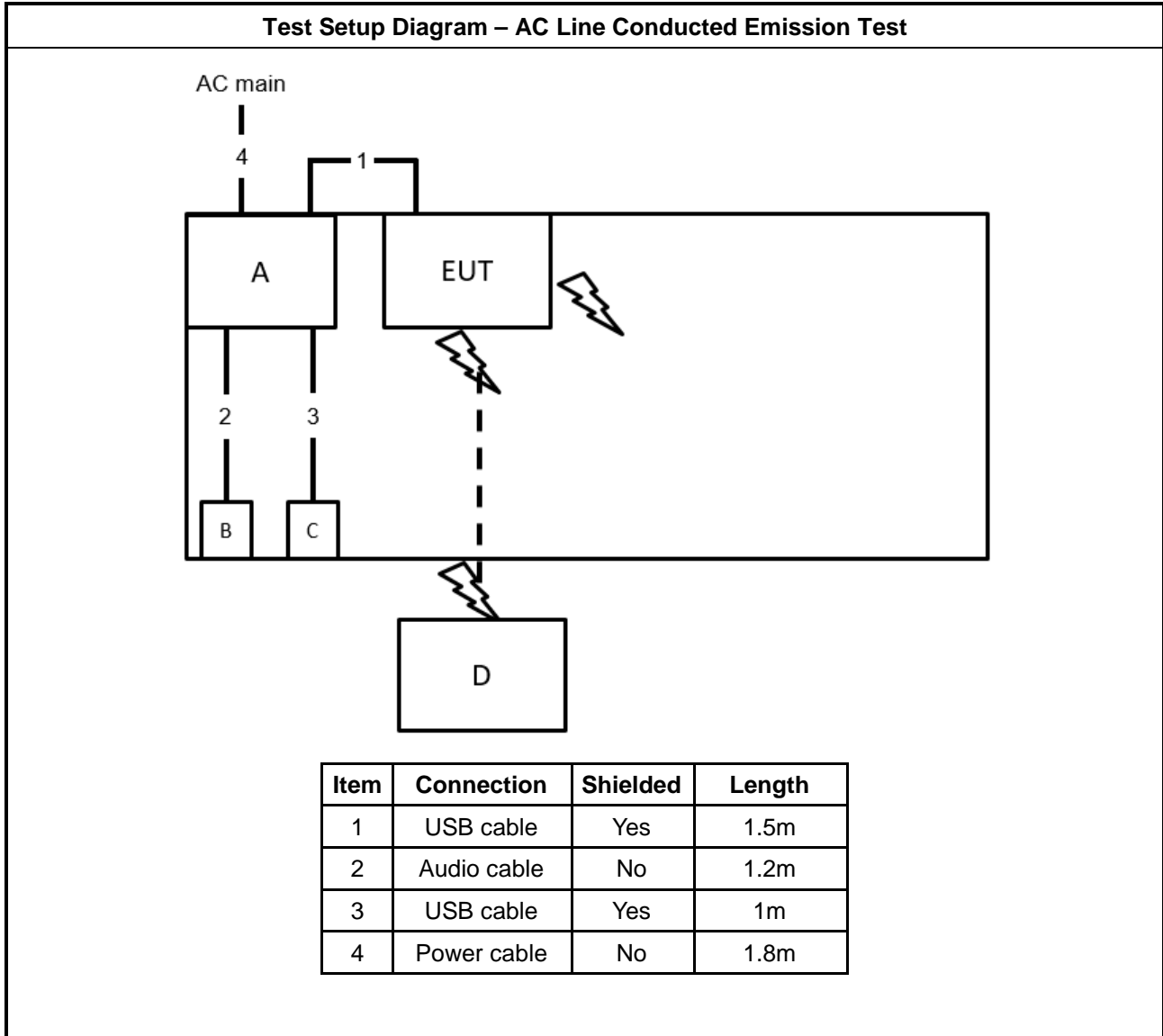

Test Setup Diagram - Radiated Test < 1GHz

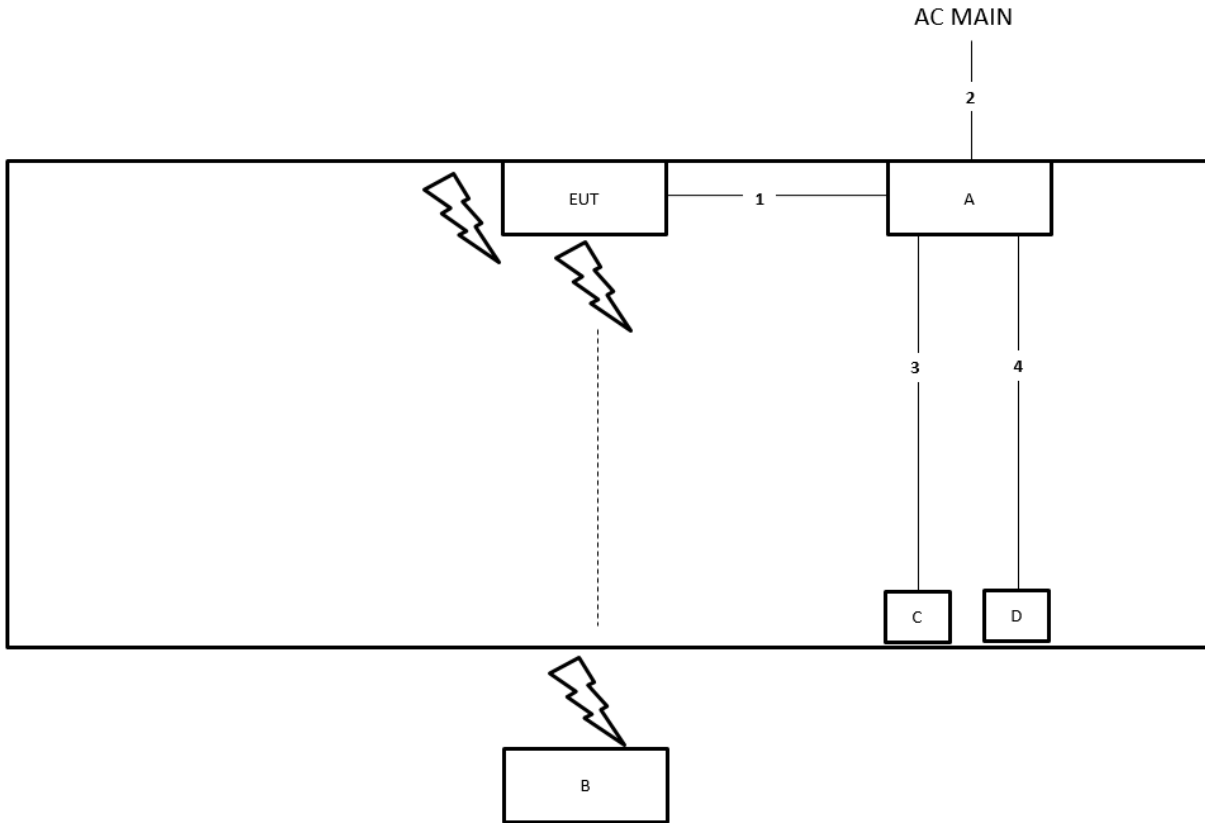

Item	Connection	Shielded	Length
1	USB cable	Yes	1.5m
2	Power cable	No	1.2m
3	Audio cable	No	1.2m
4	USB cable	Yes	1m



Test Setup Diagram - Radiated Test > 1GHz

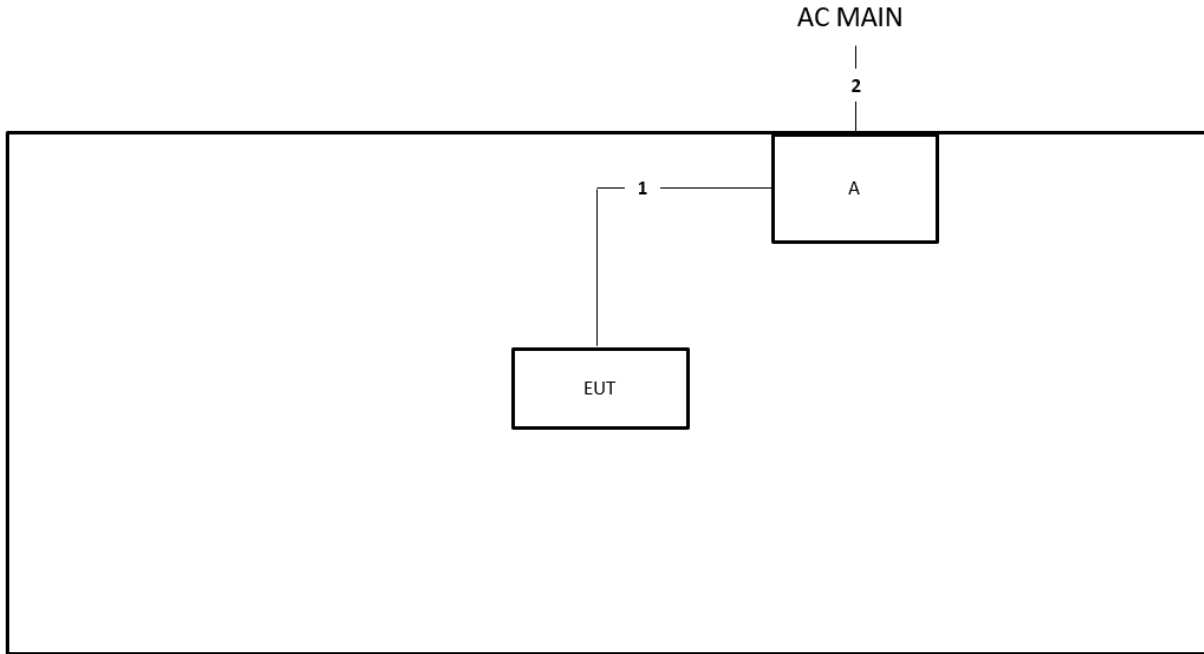

Item	Connection	Shielded	Length
1	USB cable	Yes	1.5m
2	Power cable	No	1.2m



3 Transmitter Test Result

3.1 AC Power-line Conducted Emissions

3.1.1 AC Power-line Conducted Emissions Limit

AC Power-line Conducted Emissions Limit		
Frequency Emission (MHz)	Quasi-Peak	Average
0.15-0.5	66 - 56 *	56 - 46 *
0.5-5	56	46
5-30	60	50

Note 1: * Decreases with the logarithm of the frequency.

3.1.2 Measuring Instruments

Refer a test equipment and calibration data table in this test report.

3.1.3 Test Procedures

Test Method
▪ Refer as ANSI C63.10-2013, clause 6.2 for AC power-line conducted emissions.

3.1.4 Test Setup

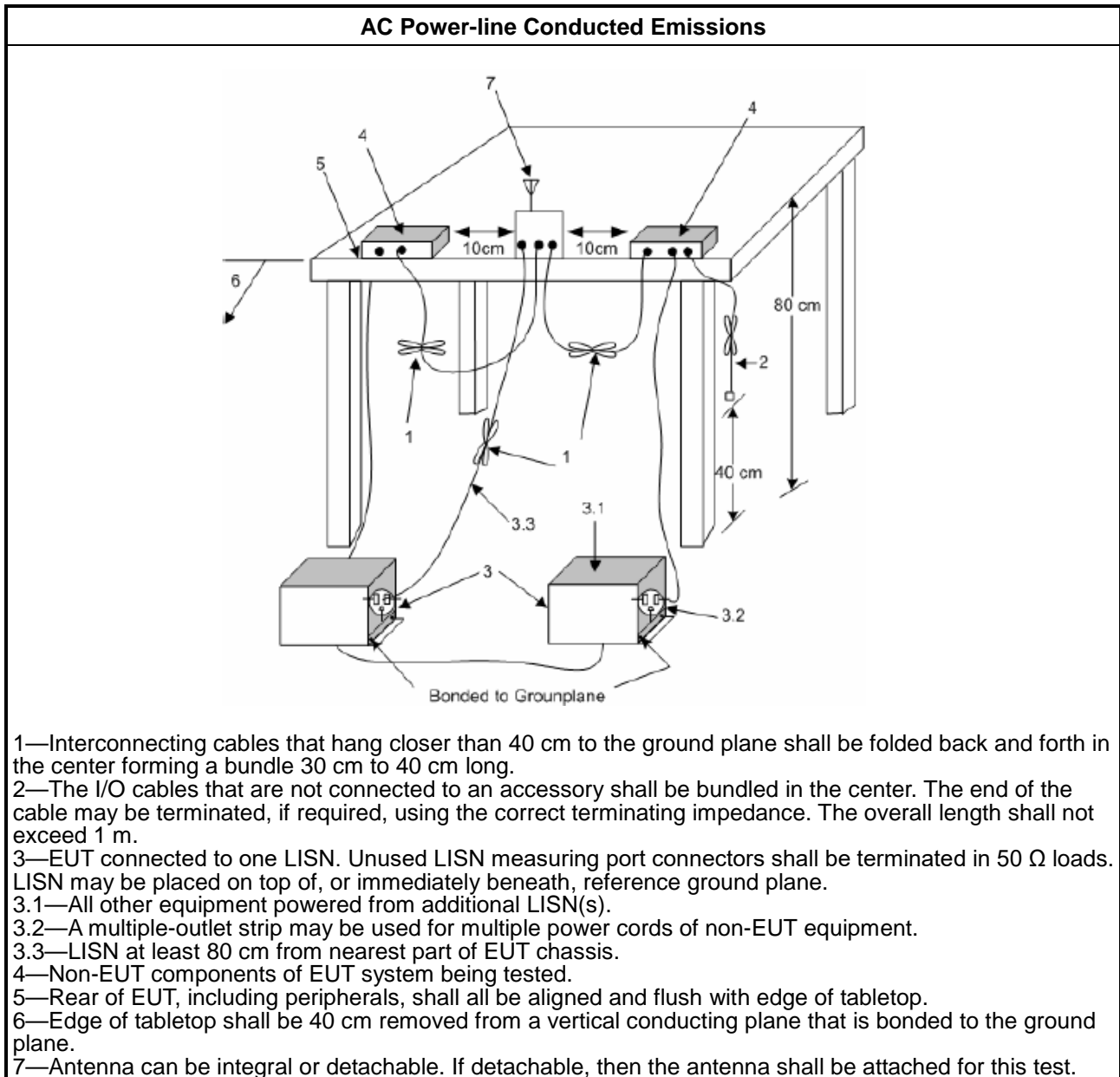

1.1.1. Measurement Results Calculation

The measured Level is calculated using:

- a. Corrected Reading: LISN Factor (LISN) + Attenuator (AT/AUX) + Cable Loss (CL) + Read Level (Raw) = Level
- b. Margin = -Limit + Level

3.1.5 Test Result of AC Power-line Conducted Emissions

Refer as Appendix A

3.2 DTS Bandwidth

3.2.1 6dB Bandwidth Limit

6dB Bandwidth Limit
Systems using digital modulation techniques:
<ul style="list-style-type: none"> ▪ 6 dB bandwidth \geq 500 kHz.

3.2.2 Measuring Instruments

Refer a test equipment and calibration data table in this test report.

3.2.3 Test Procedures

Test Method
<ul style="list-style-type: none"> ▪ For the emission bandwidth shall be measured using one of the options below:
<input checked="" type="checkbox"/> Refer as FCC KDB 558074, clause 8.2 & C63.10 clause 11.8.1 Option 1 for 6 dB bandwidth measurement.
<input type="checkbox"/> Refer as FCC KDB 558074, clause 8.2 & C63.10 clause 11.8.2 Option 2 for 6 dB bandwidth measurement.
<input type="checkbox"/> Refer as ANSI C63.10, clause 6.9.1 for occupied bandwidth testing.

3.2.4 Test Setup

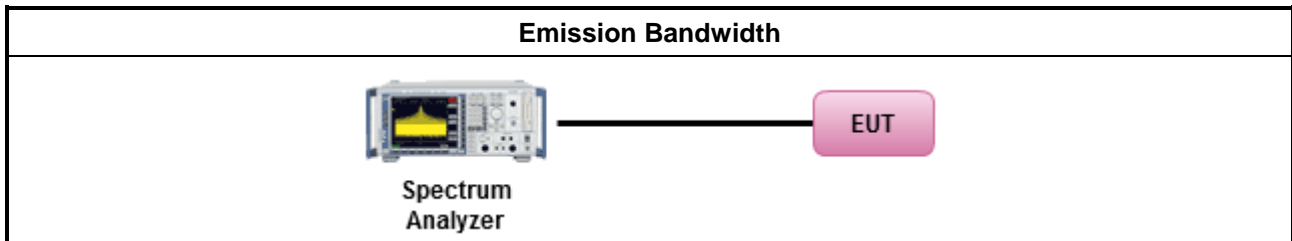

3.2.5 Test Result of Emission Bandwidth

Refer as Appendix B



3.3 Maximum Conducted Output Power

3.3.1 Maximum Conducted Output Power Limit

Maximum Conducted Output Power Limit	
	<ul style="list-style-type: none"> ▪ If $G_{TX} \leq 6$ dBi, then $P_{Out} \leq 30$ dBm (1 W)
	<ul style="list-style-type: none"> ▪ Point-to-multipoint systems (P2M): If $G_{TX} > 6$ dBi, then $P_{Out} = 30 - (G_{TX} - 6)$ dBm
	<ul style="list-style-type: none"> ▪ Point-to-point systems (P2P): If $G_{TX} > 6$ dBi, then $P_{Out} = 30 - (G_{TX} - 6)/3$ dBm
	<ul style="list-style-type: none"> ▪ Smart antenna system (SAS):
	<ul style="list-style-type: none"> - Single beam: If $G_{TX} > 6$ dBi, then $P_{Out} = 30 - (G_{TX} - 6)/3$ dBm
	<ul style="list-style-type: none"> - Overlap beam: If $G_{TX} > 6$ dBi, then $P_{Out} = 30 - (G_{TX} - 6)/3$ dBm
	<ul style="list-style-type: none"> - Aggregate power on all beams: If $G_{TX} > 6$ dBi, then $P_{Out} = 30 - (G_{TX} - 6)/3 + 8$ dB dBm
<p>P_{Out} = maximum peak conducted output power or maximum conducted output power in dBm, G_{TX} = the maximum transmitting antenna directional gain in dBi.</p>	

3.3.2 Measuring Instruments

Refer a test equipment and calibration data table in this test report.



3.3.3 Test Procedures

Test Method	
<ul style="list-style-type: none"> ▪ Maximum Peak Conducted Output Power 	
	<input type="checkbox"/> Refer as FCC KDB 558074, clause 8.3.1.1 & C63.10 clause 11.9.1.1 (RBW ≥ EBW method).
	<input type="checkbox"/> Refer as FCC KDB 558074, clause 8.3.1.3 & C63.10 clause 11.9.1.3 (peak power meter).
<ul style="list-style-type: none"> ▪ Maximum Conducted Output Power 	
[duty cycle ≥ 98% or external video / power trigger]	
	<input type="checkbox"/> Refer as FCC KDB 558074, clause 8.3.2.2 & C63.10 clause 11.9.2.2.2 Method AVGSA-1.
	<input type="checkbox"/> Refer as FCC KDB 558074, clause 8.3.2.2 & C63.10 clause 11.9.2.2.3 Method AVGSA-1A. (alternative)
duty cycle < 98% and average over on/off periods with duty factor	
	<input type="checkbox"/> Refer as FCC KDB 558074, clause 8.3.2.2 & C63.10 clause 11.9.2.2.4 Method AVGSA-2.
	<input type="checkbox"/> Refer as FCC KDB 558074, clause 8.3.2.2 & C63.10 clause 11.9.2.2.5 Method AVGSA-2A (alternative)
	<input type="checkbox"/> Refer as FCC KDB 558074, clause 8.3.2.2 & C63.10 clause 11.9.2.2.6 Method AVGSA-3
	<input type="checkbox"/> Refer as FCC KDB 558074, clause 8.3.2.2 & C63.10 clause 11.9.2.2.7 Method AVGSA-3A (alternative)
Measurement using a power meter (PM)	
	<input type="checkbox"/> Refer as FCC KDB 558074, clause 8.3.2.3 & C63.10 clause 11.9.2.3.1 Method AVGPM (using an RF average power meter).
	<input checked="" type="checkbox"/> Refer as FCC KDB 558074, clause 8.3.2.3 & C63.10 clause 11.9.2.3.2 Method AVGPM-G (using an gate RF average power meter).
<ul style="list-style-type: none"> ▪ For conducted measurement. 	
<ul style="list-style-type: none"> ▪ If the EUT supports multiple transmit chains using options given below: Refer as FCC KDB 662911, In-band power measurements. Using the measure-and-sum approach, measured all transmit ports individually. Sum the power (in linear power units e.g., mW) of all ports for each individual sample and save them. 	
<ul style="list-style-type: none"> ▪ If multiple transmit chains, EIRP calculation could be following as methods: $P_{total} = P_1 + P_2 + \dots + P_n$ (calculated in linear unit [mW] and transfer to log unit [dBm]) $EIRP_{total} = P_{total} + DG$ 	

3.3.4 Test Setup

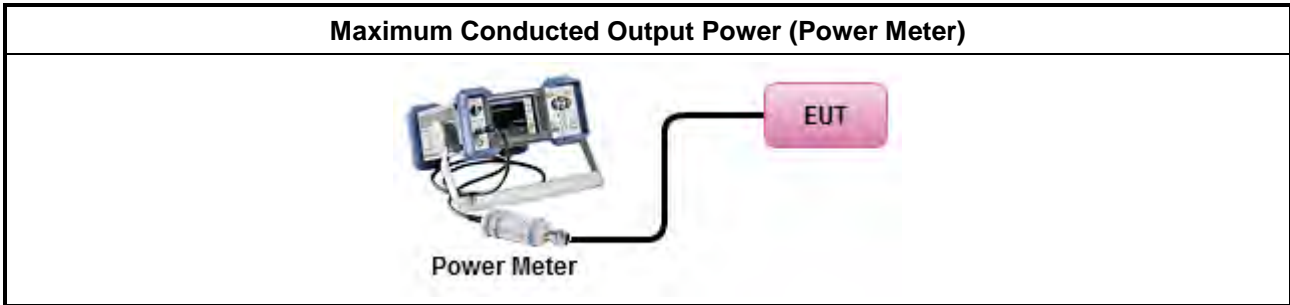

3.3.5 Test Result of Maximum Conducted Output Power

Refer as Appendix C



3.4 Power Spectral Density

3.4.1 Power Spectral Density Limit

Power Spectral Density Limit
<ul style="list-style-type: none"> Power Spectral Density (PSD) ≤ 8 dBm/3kHz

3.4.2 Measuring Instruments

Refer a test equipment and calibration data table in this test report.

3.4.3 Test Procedures

Test Method
<ul style="list-style-type: none"> Peak power spectral density procedures that the same method as used to determine the conducted output power. If maximum peak conducted output power was measured to demonstrate compliance to the output power limit, then the peak PSD procedure below (Method PKPSD) shall be used. If maximum conducted output power was measured to demonstrate compliance to the output power limit, then one of the average PSD procedures shall be used, as applicable based on the following criteria (the peak PSD procedure is also an acceptable option).
<input checked="" type="checkbox"/> Refer as FCC KDB 558074, clause 8.4 & C63.10 clause 11.10 Method Max. PSD. [duty cycle ≥ 98% or external video / power trigger]
<ul style="list-style-type: none"> For conducted measurement.
<ul style="list-style-type: none"> If The EUT supports multiple transmit chains using options given below: <ul style="list-style-type: none"> <input type="checkbox"/> Option 1: Measure and sum the spectra across the outputs. Refer as FCC KDB 662911, In-band power spectral density (PSD). Sample all transmit ports simultaneously using a spectrum analyzer for each transmit port. Where the trace bin-by-bin of each transmit port summing can be performed. (i.e., in the first spectral bin of output 1 is summed with that in the first spectral bin of output 2 and that from the first spectral bin of output 3, and so on up to the NTX output to obtain the value for the first frequency bin of the summed spectrum.). Add up the amplitude (power) values for the different transmit chains and use this as the new data trace. <input type="checkbox"/> Option 2: Measure and sum spectral maxima across the outputs. With this technique, spectra are measured at each output of the device at the required resolution bandwidth. The maximum value (peak) of each spectrum is determined. These maximum values are then summed mathematically in linear power units across the outputs. These operations shall be performed separately over frequency spans that have different out-of-band or spurious emission limits, <input type="checkbox"/> Option 3: Measure and add 10 log(N) dB, where N is the number of transmit chains. Refer as FCC KDB 662911, In-band power spectral density (PSD). Performed at each transmit chains and each transmit chains shall be compared with the limit have been reduced with 10 log(N). Or each transmit chains shall be add 10 log(N) to compared with the limit.

3.4.4 Test Setup

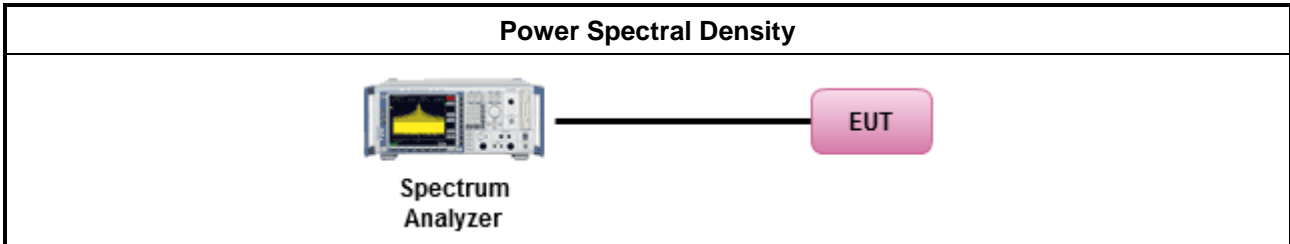

3.4.5 Test Result of Power Spectral Density

Refer as Appendix D

3.5 Emissions in Non-restricted Frequency Bands

3.5.1 Emissions in Non-restricted Frequency Bands Limit

Un-restricted Band Emissions Limit	
RF output power procedure	Limit (dBc)
Peak output power procedure	20
Average output power procedure	30

Note 1: If the peak output power procedure is used to measure the fundamental emission power to demonstrate compliance to requirements, then the peak conducted output power measured within any 100 kHz outside the authorized frequency band shall be attenuated by at least 20 dB relative to the maximum measured in-band peak PSD level.

Note 2: If the average output power procedure is used to measure the fundamental emission power to demonstrate compliance to requirements, then the power in any 100 kHz outside of the authorized frequency band shall be attenuated by at least 30 dB relative to the maximum measured in-band average PSD level.

3.5.2 Measuring Instruments

Refer a test equipment and calibration data table in this test report.

3.5.3 Test Procedures

Test Method
<ul style="list-style-type: none"> Refer as FCC KDB 558074, clause 8.5 for unwanted emissions into non-restricted bands.

3.5.4 Test Setup

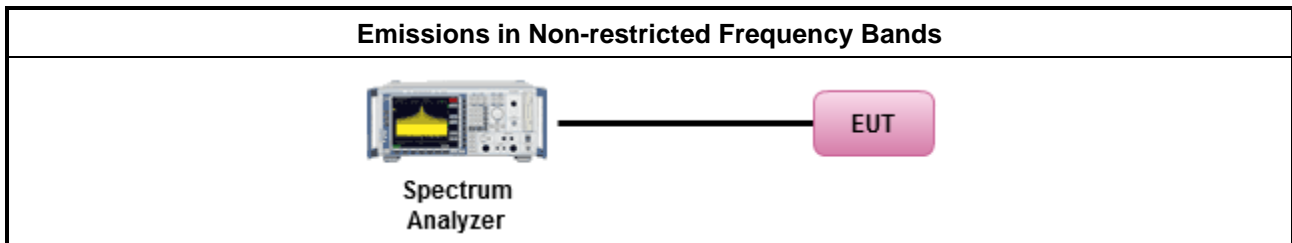

3.5.5 Test Result of Emissions in Non-restricted Frequency Bands

Refer as Appendix E



3.6 Emissions in Restricted Frequency Bands

3.6.1 Emissions in Restricted Frequency Bands Limit

Restricted Band Emissions Limit			
Frequency Range (MHz)	Field Strength (uV/m)	Field Strength (dBuV/m)	Measure Distance (m)
0.009~0.490	2400/F(kHz)	48.5 - 13.8	300
0.490~1.705	24000/F(kHz)	33.8 - 23	30
1.705~30.0	30	29	30
30~88	100	40	3
88~216	150	43.5	3
216~960	200	46	3
Above 960	500	54	3

Note 1: Test distance for frequencies at or above 30 MHz, measurements may be performed at a distance other than the limit distance provided they are not performed in the near field and the emissions to be measured can be detected by the measurement equipment. When performing measurements at a distance other than that specified, the results shall be extrapolated to the specified distance using an extrapolation factor of 20 dB/decade (inverse of linear distance for field-strength measurements, inverse of linear distance-squared for power-density measurements).

Note 2: Test distance for frequencies at below 30 MHz, measurements may be performed at a distance closer than the EUT limit distance; however, an attempt should be made to avoid making measurements in the near field. When performing measurements below 30 MHz at a closer distance than the limit distance, the results shall be extrapolated to the specified distance by either making measurements at a minimum of two or more distances on at least one radial to determine the proper extrapolation factor or by using the square of an inverse linear distance extrapolation factor (40 dB / decade). The test report shall specify the extrapolation method used to determine compliance of the EUT.

Note 3: Using the distance of 1m during the test for above 18 GHz, and the test value to correct for the distance factor at 3m.

3.6.2 Measuring Instruments

Refer a test equipment and calibration data table in this test report.



3.6.3 Test Procedures

Test Method	
<ul style="list-style-type: none"> ▪ The average emission levels shall be measured in [duty cycle \geq 98 or duty factor]. 	
<ul style="list-style-type: none"> ▪ Refer as ANSI C63.10, clause 6.10.3 band-edge testing shall be performed at the lowest frequency channel and highest frequency channel within the allowed operating band. 	
<ul style="list-style-type: none"> ▪ For the transmitter unwanted emissions shall be measured using following options below: 	
	<ul style="list-style-type: none"> ▪ Refer as FCC KDB 558074, clause 8.6 for unwanted emissions into restricted bands.
	<input type="checkbox"/> Refer as FCC KDB 558074, clause 8.6 & C63.10 clause 11.12.2.5.1(trace averaging for duty cycle \geq 98%).
	<input type="checkbox"/> Refer as FCC KDB 558074, clause 8.6 & C63.10 clause 11.12.2.5.2(trace averaging + duty factor).
	<input checked="" type="checkbox"/> Refer as FCC KDB 558074, clause 8.6 & C63.10 clause 11.12.2.5.3(Reduced VBW \geq 1/T).
	<input type="checkbox"/> Refer as ANSI C63.10, clause 11.12.2.5.3 (Reduced VBW). VBW \geq 1/T, where T is pulse time.
	<input type="checkbox"/> Refer as ANSI C63.10, clause 7.5 average value of pulsed emissions.
	<input checked="" type="checkbox"/> Refer as FCC KDB 558074, clause 8.6 & C63.10 clause 11.12.2.4 measurement procedure peak limit.
<ul style="list-style-type: none"> ▪ For the transmitter band-edge emissions shall be measured using following options below: 	
	<ul style="list-style-type: none"> ▪ Refer as FCC KDB 558074 clause 8.7 & c63.10 clause 11.13.1, When the performing peak or average radiated measurements, emissions within 2 MHz of the authorized band edge may be measured using the marker-delta method described below.
	<ul style="list-style-type: none"> ▪ Refer as FCC KDB 558074, clause 8.7 (ANSI C63.10, clause 6.10.6) for marker-delta method for band-edge measurements.
	<ul style="list-style-type: none"> ▪ Refer as FCC KDB 558074, clause 8.7 for narrower resolution bandwidth (100kHz) using the band power and summing the spectral levels (i.e., 1 MHz).
	<ul style="list-style-type: none"> ▪ For conducted unwanted emissions into restricted bands (absolute emission limits). Devices with multiple transmit chains using options given below: (1) Measure and sum the spectra across the outputs or (2) Measure and add 10 log(N) dB
	<ul style="list-style-type: none"> ▪ For FCC KDB 662911 The methodology described here may overestimate array gain, thereby resulting in apparent failures to satisfy the out-of-band limits even if the device is actually compliant. In such cases, compliance may be demonstrated by performing radiated tests around the frequencies at which the apparent failures occurred.

3.6.4 Test Setup

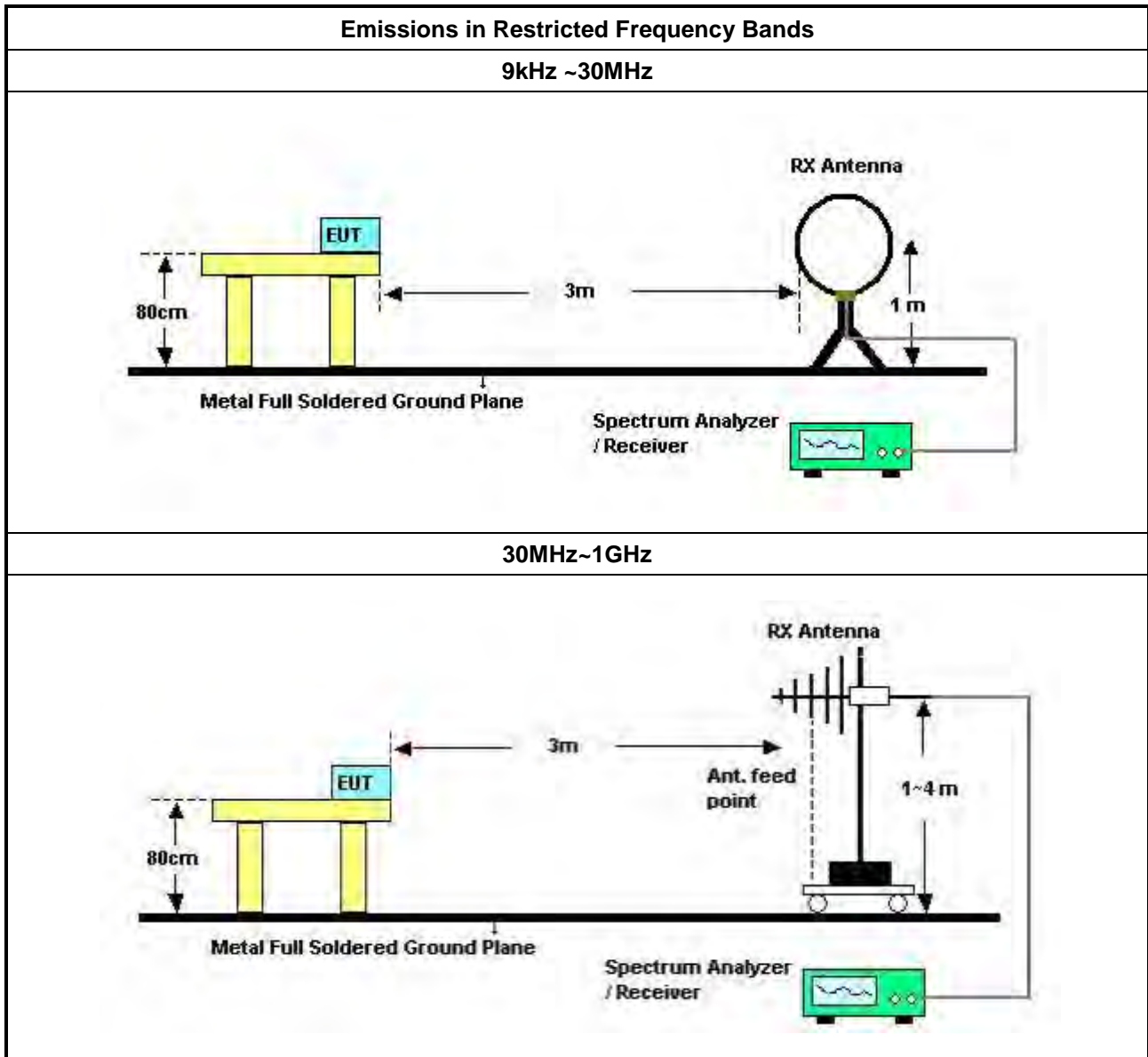

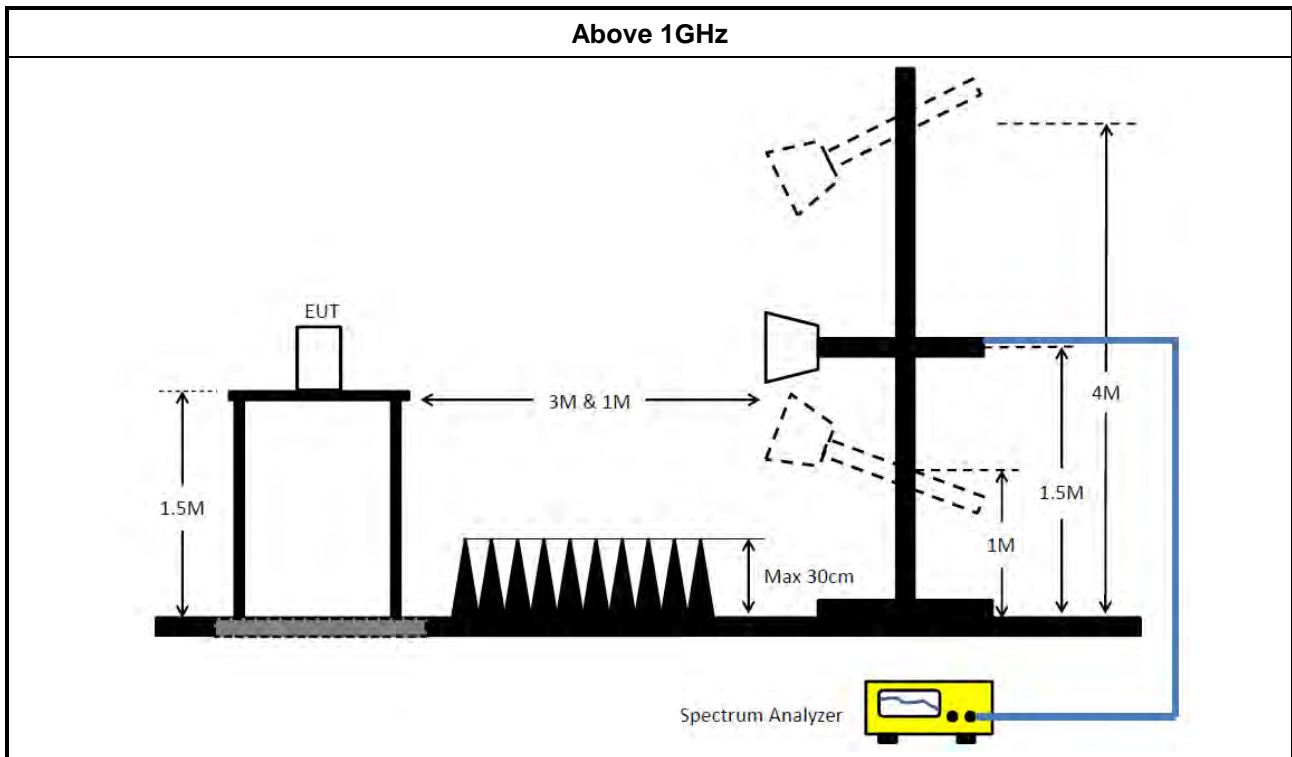

3.6.5 Measurement Results Calculation

The measured Level is calculated using:

Corrected Reading: Antenna factor (AF) + Cable loss (CL) + Read level (Raw) - Preamp factor (PA)(if applicable) = Level.

3.6.6 Emissions in Restricted Frequency Bands (Below 30MHz)

There is a comparison data of both open-field test site and alternative test site - semi-Anechoic chamber according to KDB414788 Radiated Test Site, and the result came out very similar.

All amplitude of spurious emissions that are attenuated by more than 20 dB below the permissible value has no need to be reported.

The radiated emissions were investigated from 9 kHz or the lowest frequency generated within the device, up to the 10th harmonic or 40 GHz, whichever is appropriate.

3.6.7 Test Result of Emissions in Restricted Frequency Bands

Refer as Appendix F



4 Test Equipment and Calibration Data

Instrument	Brand	Model No.	Serial No.	Characteristics	Calibration Date	Calibration Due Date	Remark
LISN	Schwarzbeck	NSLK 8127	8127650	9kHz ~ 30MHz	Apr. 06, 2023	Apr. 05, 2024	Conduction (CO02-CB)
LISN	Schwarzbeck	NSLK 8127	8127478	9kHz ~ 30MHz	Dec. 20, 2022	Dec. 19, 2023	Conduction (CO02-CB)
EMI Receiver	Agilent	N9038A	MY52260140	9kHz ~ 8.4GHz	May 18, 2023	May 17, 2024	Conduction (CO02-CB)
COND Cable	Woken	Cable	2	0.15MHz ~ 30MHz	Oct. 17, 2023	Oct. 16, 2024	Conduction (CO02-CB)
Pulse Limiter	Schwarzbeck	VTSD 9561F-N	00378	9kHz ~ 30MHz	Oct. 17, 2023	Oct. 16, 2024	Conduction (CO02-CB)
Software	SPORTON	SENSE	V5.10	-	N.C.R.	N.C.R.	Conduction (CO02-CB)
Loop Antenna	Teseq	HLA 6120	31244	9kHz - 30 MHz	Mar. 23, 2023	Mar. 22, 2024	Radiation (03CH04-CB)
3m Semi Anechoic Chamber NSA	TDK	SAC-3M	03CH04-CB	30 MHz ~ 1 GHz	Aug. 01, 2023	Jul. 31, 2024	Radiation (03CH04-CB)
BILOG ANTENNA with 6 dB attenuator	Schaffner & EMCi	CBL6112B & N-6-06	22021&AT-N0607	30MHz ~ 1GHz	Oct. 08, 2022	Oct. 07, 2023	Radiation (03CH04-CB)
BILOG ANTENNA with 6 dB attenuator	Schaffner & EMCi	CBL6112B & N-6-06	22021&AT-N0607	30MHz ~ 1GHz	Oct. 07, 2023	Oct. 06, 2024	Radiation (03CH04-CB)
Pre-Amplifier	EMCI	EMC330N	980391	20MHz ~ 3GHz	May 23, 2023	May 22, 2024	Radiation (03CH04-CB)
Spectrum Analyzer	R&S	FSP40	100142	9kHz~40GHz	Mar. 21, 2023	Mar. 20, 2024	Radiation (03CH04-CB)
EMI Test Receiver	R&S	ESCS	826547/017	9kHz ~ 2.75GHz	Jun. 13, 2023	Jun. 12, 2024	Radiation (03CH04-CB)
RF Cable-low	Woken	RG402	Low Cable-03+67	30MHz – 1GHz	Oct. 03, 2022	Oct. 02, 2023	Radiation (03CH04-CB)
RF Cable-low	Woken	RG402	Low Cable-03+67	30MHz – 1GHz	Oct. 02, 2023	Oct. 01, 2024	Radiation (03CH04-CB)
Test Software	SPORTON	SENSE	V5.10	-	N.C.R.	N.C.R.	Radiation (03CH04-CB)
3m Semi Anechoic Chamber VSWR	TDK	SAC-3M	03CH05-CB	1GHz ~18GHz 3m	Nov. 06, 2022	Nov. 05, 2023	Radiation (03CH05-CB)
Horn Antenna	SCHWARZBECK	BBHA9120D	BBHA 9120 D-1291	1GHz~18GHz	Jun. 08, 2023	Jun. 07, 2024	Radiation (03CH05-CB)
Horn Antenna	SCHWARZBECK	BBHA 9170	BBHA9170507	15GHz ~ 40GHz	Jun. 28, 2023	Jun. 27, 2024	Radiation (03CH05-CB)



Instrument	Brand	Model No.	Serial No.	Characteristics	Calibration Date	Calibration Due Date	Remark
Pre-Amplifier	EMCI	EMC12630SE	980287	1GHz – 26.5GHz	Jun. 30, 2023	Jun. 29, 2024	Radiation (03CH05-CB)
Pre-Amplifier	SGH	SGH184	20221107-3	18GHz ~ 40GHz	Nov. 16, 2022	Nov. 15, 2023	Radiation (03CH05-CB)
Spectrum Analyzer	R&S	FSP40	100304	9kHz ~ 40GHz	Apr. 18, 2023	Apr. 17, 2024	Radiation (03CH05-CB)
RF Cable-high	Woken	RG402	High Cable-28	1GHz~18GHz	Oct. 03, 2022	Oct. 02, 2023	Radiation (03CH05-CB)
RF Cable-high	Woken	RG402	High Cable-28	1GHz~18GHz	Oct. 02, 2023	Oct. 01, 2024	Radiation (03CH05-CB)
RF Cable-high	Woken	RG402	High Cable-04+28	1GHz~18GHz	Oct. 03, 2022	Oct. 02, 2023	Radiation (03CH05-CB)
RF Cable-high	Woken	RG402	High Cable-04+28	1GHz~18GHz	Oct. 02, 2023	Oct. 01, 2024	Radiation (03CH05-CB)
High Cable	Woken	WCA0929M	40G#5+6	1GHz ~ 40 GHz	Dec. 07, 2022	Dec. 06, 2023	Radiation (03CH05-CB)
High Cable	Woken	WCA0929M	40G#5	1GHz ~ 40 GHz	Dec. 07, 2022	Dec. 06, 2023	Radiation (03CH05-CB)
High Cable	Woken	WCA0929M	40G#6	1GHz ~ 40 GHz	Dec. 07, 2022	Dec. 06, 2023	Radiation (03CH05-CB)
Test Software	SPORTON	SENSE	V5.10	-	N.C.R.	N.C.R.	Radiation (03CH05-CB)
Spectrum analyzer	R&S	FSV40	100979	9kHz~40GHz	May 29, 2023	May 28, 2024	Conducted (TH01-CB)
Switch	SPTCB	SP-SWI	SWI-01	1 GHz –26.5 GHz	Oct. 04, 2022	Oct. 03, 2023	Conducted (TH01-CB)
Switch	SPTCB	SP-SWI	SWI-01	1 GHz –26.5 GHz	Oct. 04, 2022	Oct. 03, 2023	Conducted (TH01-CB)
RF Cable-high	Woken	RG402	High Cable-06	1 GHz – 18 GHz	Oct. 03, 2022	Oct. 02, 2023	Conducted (TH01-CB)
RF Cable-high	Woken	RG402	High Cable-06	1 GHz – 18 GHz	Oct. 02, 2023	Oct. 01, 2024	Conducted (TH01-CB)
RF Cable-high	Woken	RG402	High Cable-07	1 GHz – 18 GHz	Oct. 03, 2022	Oct. 02, 2023	Conducted (TH01-CB)
RF Cable-high	Woken	RG402	High Cable-07	1 GHz – 18 GHz	Oct. 02, 2023	Oct. 01, 2024	Conducted (TH01-CB)
RF Cable-high	Woken	RG402	High Cable-08	1 GHz – 18 GHz	Oct. 03, 2022	Oct. 02, 2023	Conducted (TH01-CB)
RF Cable-high	Woken	RG402	High Cable-08	1 GHz – 18 GHz	Oct. 02, 2023	Oct. 01, 2024	Conducted (TH01-CB)
RF Cable-high	Woken	RG402	High Cable-09	1 GHz – 18 GHz	Oct. 03, 2022	Oct. 02, 2023	Conducted (TH01-CB)
RF Cable-high	Woken	RG402	High Cable-09	1 GHz – 18 GHz	Oct. 02, 2023	Oct. 01, 2024	Conducted (TH01-CB)
RF Cable-high	Woken	RG402	High Cable-10	1 GHz – 18 GHz	Oct. 03, 2022	Oct. 02, 2023	Conducted (TH01-CB)



Instrument	Brand	Model No.	Serial No.	Characteristics	Calibration Date	Calibration Due Date	Remark
RF Cable-high	Woken	RG402	High Cable-10	1 GHz – 18 GHz	Oct. 02, 2023	Oct. 01, 2024	Conducted (TH01-CB)
RF Cable-high	Woken	RG402	High Cable-30	1 GHz – 18 GHz	Oct. 03, 2022	Oct. 02, 2023	Conducted (TH01-CB)
RF Cable-high	Woken	RG402	High Cable-30	1 GHz – 18 GHz	Oct. 02, 2023	Oct. 01, 2024	Conducted (TH01-CB)
Power Sensor	Agilent	E9327A	US40442088	50MHz~18GHz	Feb. 22, 2023	Feb. 21, 2024	Conducted (TH01-CB)
Power Meter	Agilent	E4416A	GB41291199	50MHz~18GHz	Feb. 22, 2023	Feb. 21, 2024	Conducted (TH01-CB)
Test Software	SPORTON	SENSE	V5.10	-	N.C.R.	N.C.R.	Conducted (TH01-CB)

Note: Calibration Interval of instruments listed above is one year.

NCR means Non-Calibration required.



Summary

Mode	Result	Type	Freq (Hz)	Level (dBuV)	Limit (dBuV)	Margin (dB)	Condition
Mode 3	Pass	QP	150k	52.85	66.00	-13.15	Line

Mode 3

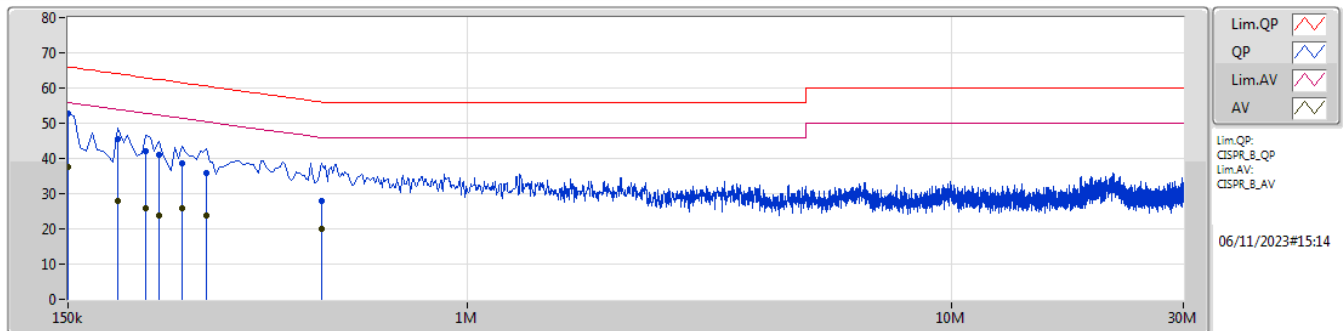

Type	Freq (Hz)	Level (dBuV)	Limit (dBuV)	Margin (dB)	Factor (dB)	Condition	Comment	Raw (dBuV)	LISN (dB)	CL (dB)	AT (dB)
QP	150k	52.85	66.00	-13.15	10.08	Line	"Worst"	42.77	0.04	0.03	10.01
AV	150k	37.65	56.00	-18.35	10.08	Line	-	27.57	0.04	0.03	10.01
QP	190.5k	45.66	64.01	-18.35	10.06	Line	-	35.60	0.04	0.03	9.99
AV	190.5k	27.81	54.01	-26.20	10.06	Line	-	17.75	0.04	0.03	9.99
QP	217.5k	42.16	62.92	-20.76	10.06	Line	-	32.10	0.04	0.03	9.99
AV	217.5k	25.72	52.92	-27.20	10.06	Line	-	15.66	0.04	0.03	9.99
QP	231k	40.94	62.41	-21.47	10.06	Line	-	30.88	0.04	0.03	9.99
AV	231k	23.91	52.41	-28.50	10.06	Line	-	13.85	0.04	0.03	9.99
QP	258k	38.53	61.49	-22.96	10.06	Line	-	28.47	0.04	0.03	9.99
AV	258k	25.76	51.49	-25.73	10.06	Line	-	15.70	0.04	0.03	9.99
QP	289.5k	35.98	60.53	-24.55	10.07	Line	-	25.91	0.04	0.03	10.00
AV	289.5k	23.87	50.53	-26.66	10.07	Line	-	13.80	0.04	0.03	10.00
QP	500k	28.03	56.00	-27.97	10.07	Line	-	17.96	0.04	0.03	10.00
AV	500k	19.84	46.00	-26.16	10.07	Line	-	9.77	0.04	0.03	10.00

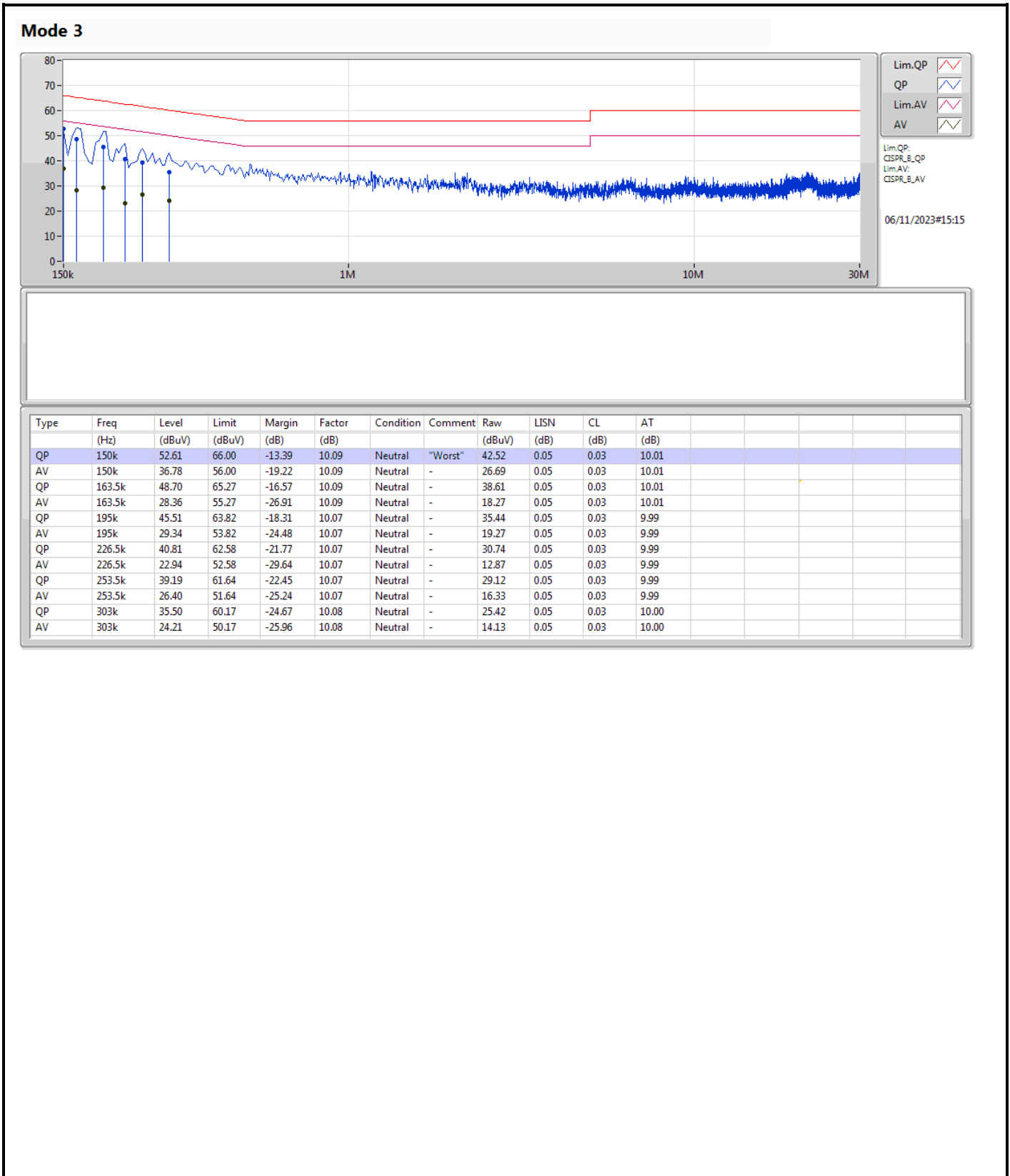



Summary

Mode	Max-N dB (Hz)	Max-OBW (Hz)	ITU-Code	Min-N dB (Hz)	Min-OBW (Hz)
2.4-2.4835GHz	-	-	-	-	-
GFSK_1MHz_Nss1_1TX	505k	946.335k	946KF1D	505k	946.335k

Max-N dB = Maximum 6dB down bandwidth; Max-OBW = Maximum 99% occupied bandwidth;
Min-N dB = Minimum 6dB down bandwidth; Min-OBW = Minimum 99% occupied bandwidth



Result

Mode	Result	Limit (Hz)	Port 1-N dB (Hz)	Port 1-OBW (Hz)
GFSK_1MHz_Nss1_1TX	-	-	-	-
2457MHz	Pass	500k	505k	946.335k

Port X-N dB = Port X 6dB down bandwidth;
Port X-OBW = Port X 99% occupied bandwidth

2.4-2.4835GHz_GFSK_1MHz_Nss1_1TX

EBW

2457MHz

13/10/2023

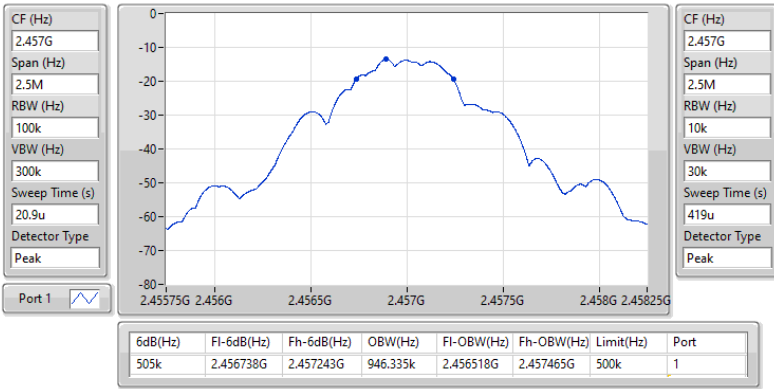



Summary

Mode	Total Power (dBm)	Total Power (W)
2.4-2.4835GHz	-	-
GFSK_1MHz_Nss1_1TX	-12.39	0.00006



Result

Mode	Result	DG (dBi)	Port 1 (dBm)	Total Power (dBm)	Power Limit (dBm)
GFSK_1MHz_Nss1_1TX	-	-	-	-	-
2457MHz	Pass	1.50	-12.39	-12.39	30.00

DG = Directional Gain; Port X = Port X output power



Summary

Mode	PD (dBm/RBW)
2.4-2.4835GHz	-
GFSK_1MHz_Nss1_1TX	-22.23

RBW = 3kHz;



Result

Mode	Result	DG (dBi)	Port 1 (dBm/RBW)	PD (dBm/RBW)	PD Limit (dBm/RBW)
GFSK_1MHz_Nss1_1TX	-	-	-	-	-
2457MHz	Pass	1.50	-22.23	-22.23	8.00

DG = Directional Gain; RBW = 3kHz;
PD = trace bin-by-bin of each transmits port summing can be performed maximum power density; Port X = Port X Power Density;

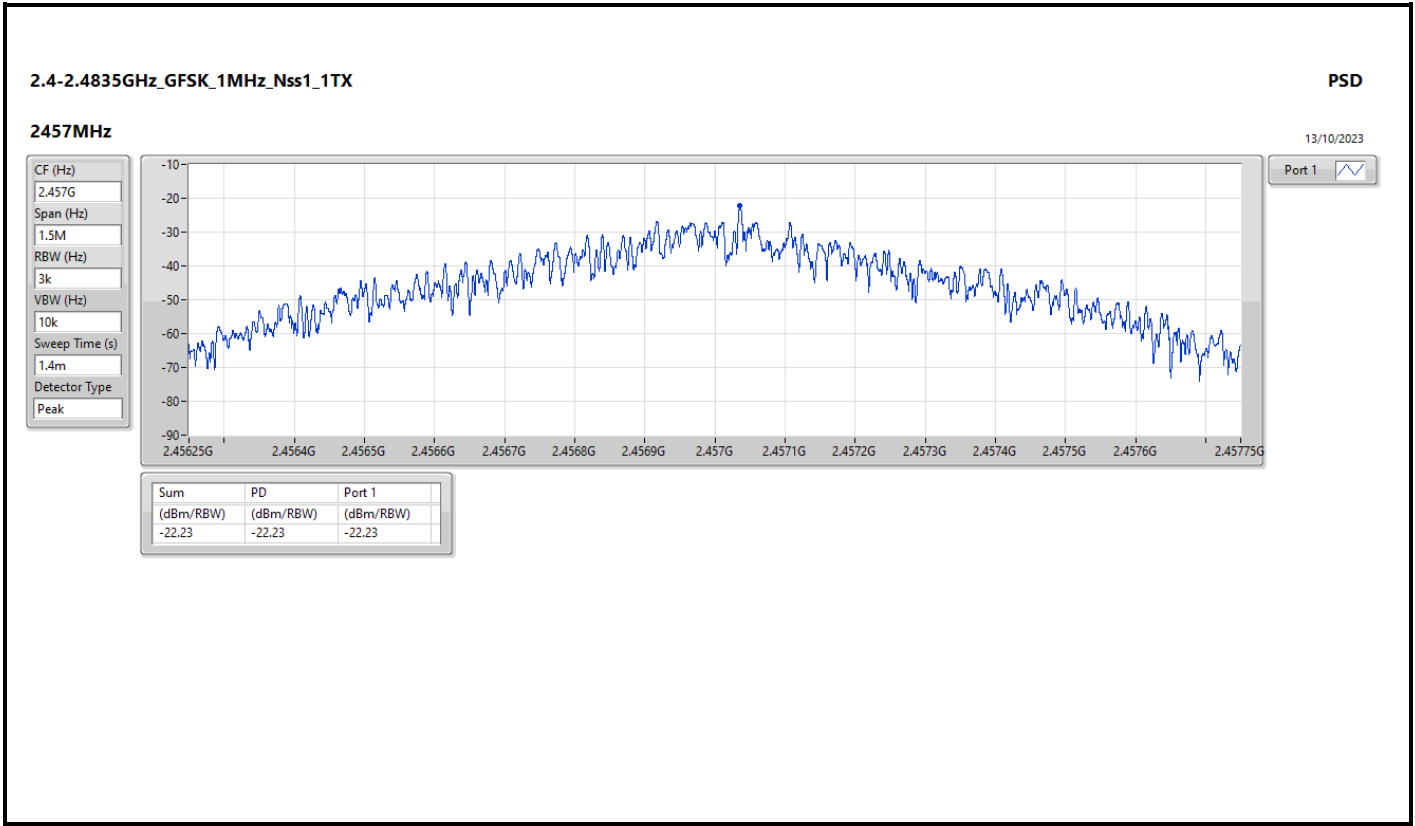



Summary

Mode	Result	Ref (Hz)	Ref (dBm)	Limit (dBm)	Freq (Hz)	Level (dBm)	Freq (Hz)	Level (dBm)	Freq (Hz)	Level (dBm)	Freq (Hz)	Level (dBm)	Port
2.4-2.4835GHz	-	-	-	-	-	-	-	-	-	-	-	-	-
GFSK_1MHz_Nss1_1TX	Pass	2.45695G	-12.57	-42.57	52.5M	-54.09	2.39824G	-50.56	2.4G	-56.41	21.5778G	-45.97	1



Result

Mode	Result	Ref (Hz)	Ref (dBm)	Limit (dBm)	Freq (Hz)	Level (dBm)	Freq (Hz)	Level (dBm)	Freq (Hz)	Level (dBm)	Freq (Hz)	Level (dBm)	Port
GFSK_1MHz_Nss1_1TX	-	-	-	-	-	-	-	-	-	-	-	-	-
2457MHz	Pass	2.45695G	-12.57	-42.57	52.5M	-54.09	2.39824G	-50.56	2.4G	-56.41	21.5778G	-45.97	1

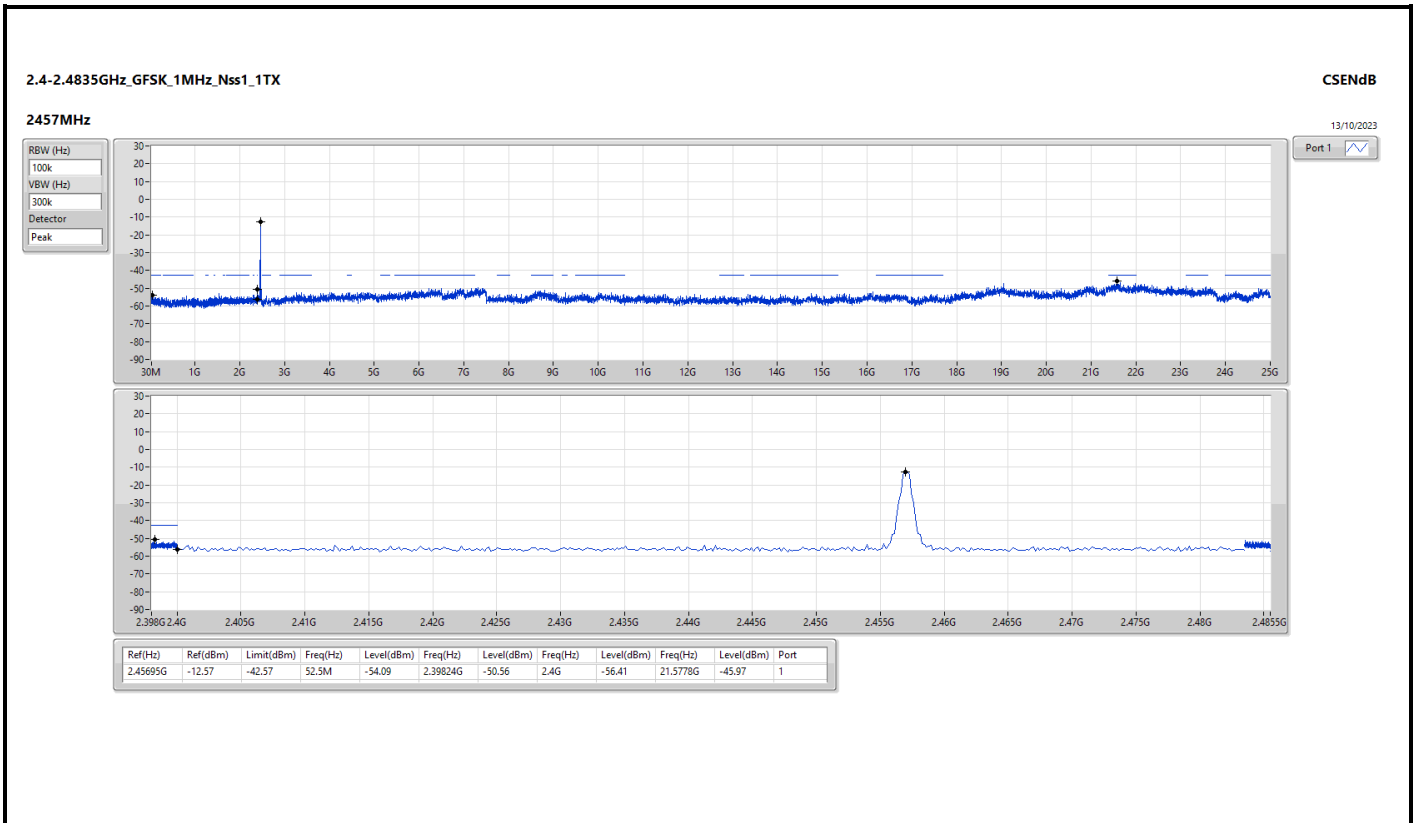



Summary

Mode	Result	Type	Freq (Hz)	Level (dBuV/m)	Limit (dBuV/m)	Margin (dB)	Condition
Mode 4	Pass	PK	49.4M	35.50	40.00	-4.50	Vertical

Mode 4

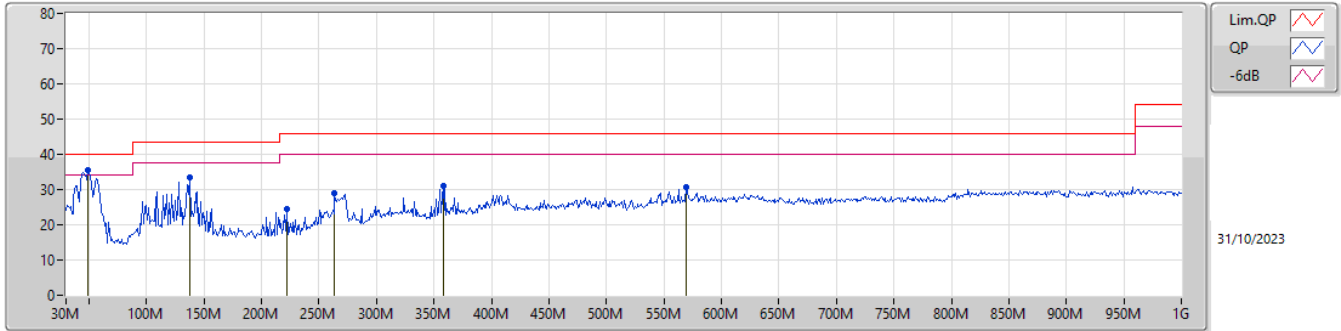

Type	Freq (Hz)	Level (dBuV/m)	Limit (dBuV/m)	Margin (dB)	Factor (dB/m)	Dist (m)	Condition	Azimuth (°)	Height (m)	Comment	Raw (dBuV/m)	AF (dB/m)	CL (dB)	PA (dB)
PK	49.4M	35.50	40.00	-4.50	-16.86	3	Vertical	299	1.00	"Worst"	52.36	14.16	0.53	31.55
PK	137.67M	33.58	43.50	-9.92	-12.74	3	Vertical	6	1.25	-	46.32	18.00	1.07	31.81
PK	222.06M	24.32	46.00	-21.68	-14.95	3	Vertical	130	1.00	-	39.27	15.49	1.35	31.79
PK	263.77M	28.80	46.00	-17.20	-11.26	3	Vertical	164	2.00	-	40.06	19.03	1.52	31.81
PK	357.86M	31.04	46.00	-14.96	-9.50	3	Vertical	3	2.00	-	40.54	20.51	1.81	31.82
PK	569.32M	30.62	46.00	-15.38	-5.20	3	Vertical	31	2.90	-	35.82	24.58	2.36	32.14

Mode 4

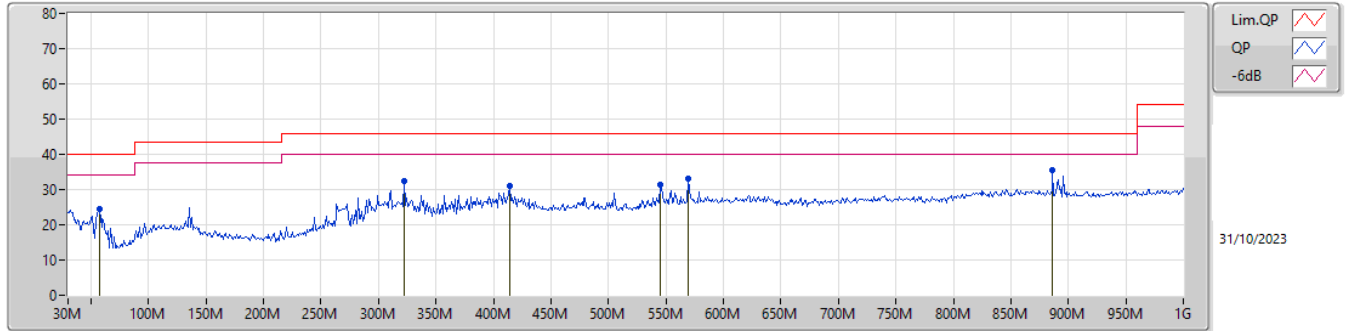

Type	Freq (Hz)	Level (dBuV/m)	Limit (dBuV/m)	Margin (dB)	Factor (dB/m)	Dist (m)	Condition	Azimuth (°)	Height (m)	Comment	Raw (dBuV/m)	AF (dB/m)	CL (dB)	PA (dB)
PK	57.16M	24.43	40.00	-15.57	-18.25	3	Horizontal	334	3.00	-	42.68	12.89	0.57	31.71
PK	321.97M	32.33	46.00	-13.67	-10.66	3	Horizontal	154	1.00	-	42.99	19.44	1.72	31.82
PK	414.12M	31.08	46.00	-14.92	-7.74	3	Horizontal	115	1.00	-	38.82	22.27	2.00	32.01
PK	545.07M	31.39	46.00	-14.61	-4.95	3	Horizontal	225	2.00	-	36.34	24.87	2.31	32.13
PK	569.32M	33.19	46.00	-12.81	-5.20	3	Horizontal	3	1.00	-	38.39	24.58	2.36	32.14
PK	886.51M	35.62	46.00	-10.38	-2.70	3	Horizontal	95	1.00	"Worst"	38.32	26.50	3.03	32.23



Summary

Mode	Result	Type	Freq (Hz)	Level (dBuV/m)	Limit (dBuV/m)	Margin (dB)	Dist (m)	Condition	Azimuth (°)	Height (m)	Comments
2.4-2.4835GHz	-	-	-	-	-	-	-	-	-	-	-
GFSK_1MHz_Nss1_1TX	Pass	AV	7.37088G	50.30	54.00	-3.70	3	Vertical	321	1.80	-

2.4-2.4835GHz_GFSK_1MHz_Nss1_1TX

2457MHz_TX

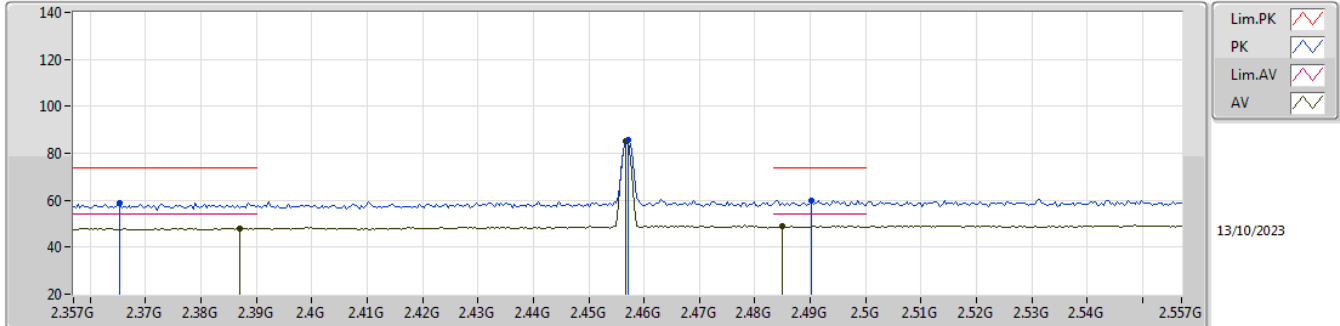

EUT Y_1TX
Setting -4
05-M-A-4

Type	Freq (Hz)	Level (dBuV/m)	Limit (dBuV/m)	Margin (dB)	Raw (dBuV)	Dist (m)	Condition	Azimuth (°)	Height (m)	Comment	AF (dB)	CL (dB)	PA (dB)
PK	2.3654G	58.70	74.00	-15.30	26.73	3	Vertical	278	1.80	-	27.30	4.67	-
AV	2.387G	48.17	54.00	-5.83	16.10	3	Vertical	278	1.80	-	27.37	4.70	-
PK	2.457G	85.61	Inf	-Inf	53.06	3	Vertical	278	1.80	-	27.77	4.78	-
AV	2.4566G	84.96	Inf	-Inf	52.41	3	Vertical	278	1.80	-	27.77	4.78	-
PK	2.4902G	59.70	74.00	-14.30	26.98	3	Vertical	278	1.80	-	27.90	4.82	-
AV	2.485G	49.13	54.00	-4.87	16.41	3	Vertical	278	1.80	-	27.90	4.82	-

2.4-2.4835GHz_GFSK_1MHz_Nss1_1TX

2457MHz_TX

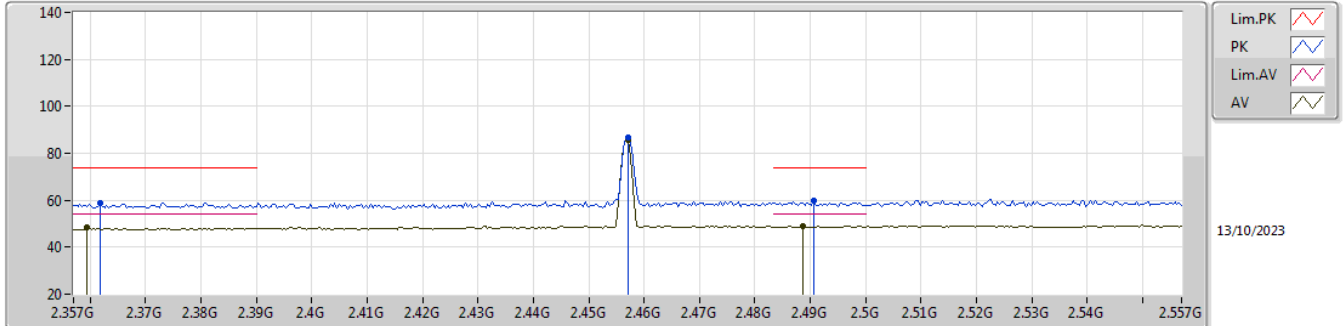

EUT Y_1TX
Setting -4
05-M-A-4

Type	Freq (Hz)	Level (dBuV/m)	Limit (dBuV/m)	Margin (dB)	Raw (dBuV)	Dist (m)	Condition	Azimuth (°)	Height (m)	Comment	AF (dB)	CL (dB)	PA (dB)
PK	2.3618G	58.91	74.00	-15.09	26.94	3	Horizontal	26	2.86	-	27.30	4.67	-
AV	2.3594G	48.35	54.00	-5.65	16.39	3	Horizontal	26	2.86	-	27.29	4.67	-
PK	2.457G	86.50	Inf	-Inf	53.95	3	Horizontal	26	2.86	-	27.77	4.78	-
AV	2.457G	85.88	Inf	-Inf	53.33	3	Horizontal	26	2.86	-	27.77	4.78	-
PK	2.4906G	59.77	74.00	-14.23	27.05	3	Horizontal	26	2.86	-	27.90	4.82	-
AV	2.4886G	49.12	54.00	-4.88	16.40	3	Horizontal	26	2.86	-	27.90	4.82	-

2.4-2.4835GHz_GFSK_1MHz_Nss1_1TX

2457MHz_TX

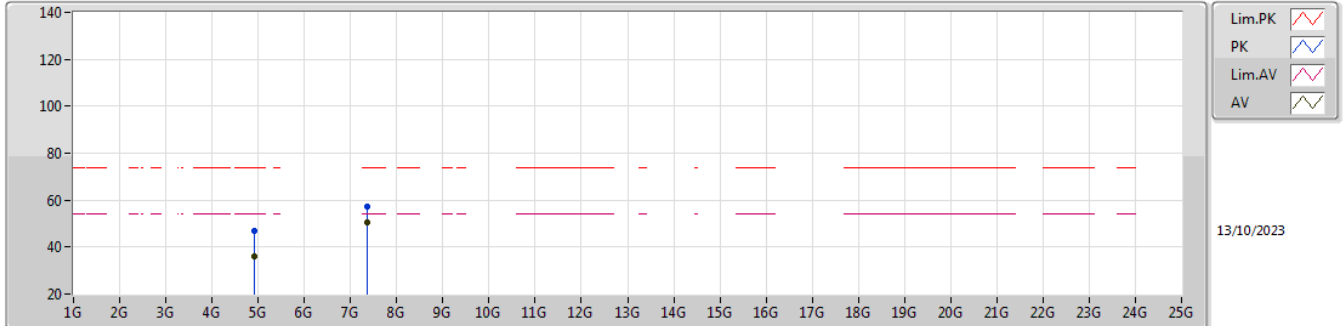

EUT Y_1TX
Setting -4
05-M-A-4

Type	Freq (Hz)	Level (dBuV/m)	Limit (dBuV/m)	Margin (dB)	Raw (dBuV)	Dist (m)	Condition	Azimuth (°)	Height (m)	Comment	AF (dB)	CL (dB)	PA (dB)
PK	4.91388G	46.96	74.00	-27.04	42.57	3	Vertical	20	2.18	-	32.76	7.21	35.58
AV	4.91384G	36.14	54.00	-17.86	31.75	3	Vertical	20	2.18	-	32.76	7.21	35.58
PK	7.37156G	57.50	74.00	-16.50	46.87	3	Vertical	321	1.80	-	36.66	8.63	34.66
AV	7.37088G	50.30	54.00	-3.70	39.67	3	Vertical	321	1.80	-	36.66	8.63	34.66

2.4-2.4835GHz_GFSK_1MHz_Nss1_1TX

2457MHz_TX

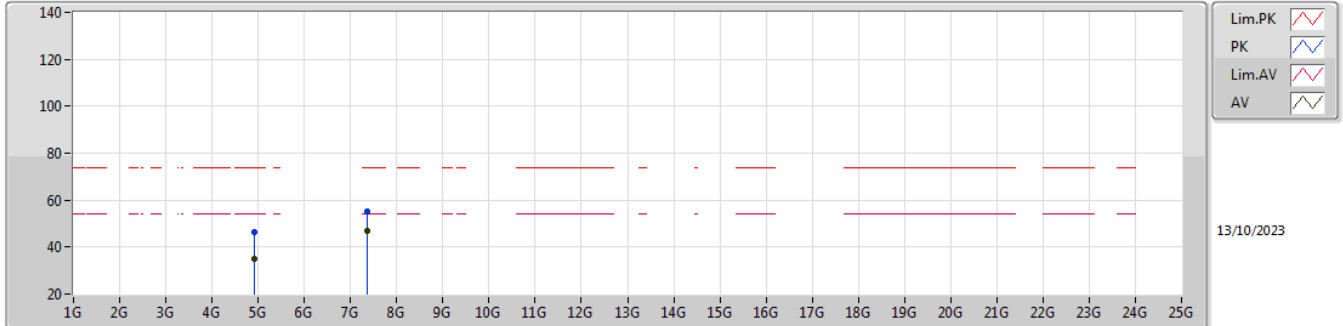

EUT Y_1TX
Setting -4
05-M-A-4

Type	Freq (Hz)	Level (dBuV/m)	Limit (dBuV/m)	Margin (dB)	Raw (dBuV)	Dist (m)	Condition	Azimuth (°)	Height (m)	Comment	AF (dB)	CL (dB)	PA (dB)
PK	4.91062G	46.22	74.00	-27.78	41.85	3	Horizontal	230	1.00	-	32.74	7.21	35.58
AV	4.91844G	35.03	54.00	-18.97	30.63	3	Horizontal	230	1.00	-	32.77	7.21	35.58
PK	7.37152G	55.38	74.00	-18.62	44.75	3	Horizontal	21	2.34	-	36.66	8.63	34.66
AV	7.3707G	46.64	54.00	-7.36	36.02	3	Horizontal	21	2.34	-	36.66	8.63	34.67