

Operate the signage

1. Switch on the Power

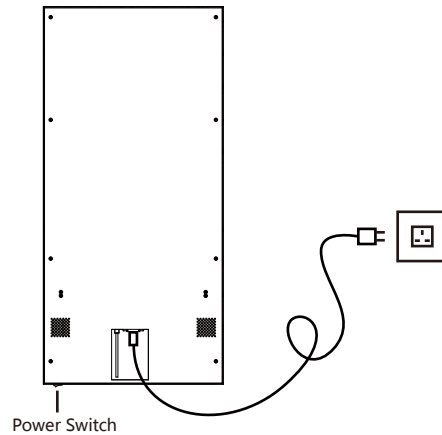

2. Internet connecting

It needs to exit from Onsign App firstly in order to set up a new connection via wifi. For doing it, please plug a mouse into a USB port, and exit from the Onsign App by clicking the mouse.

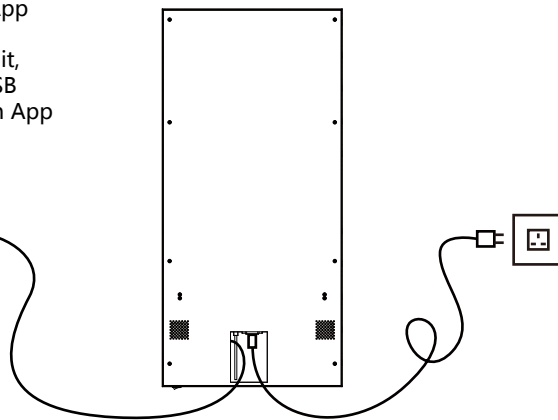
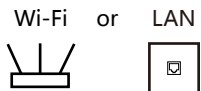

3. Contents playback

Onsign is a thirdparty App for content playback. It has been installed in the signage. For further information, please go to www.onsign.tv

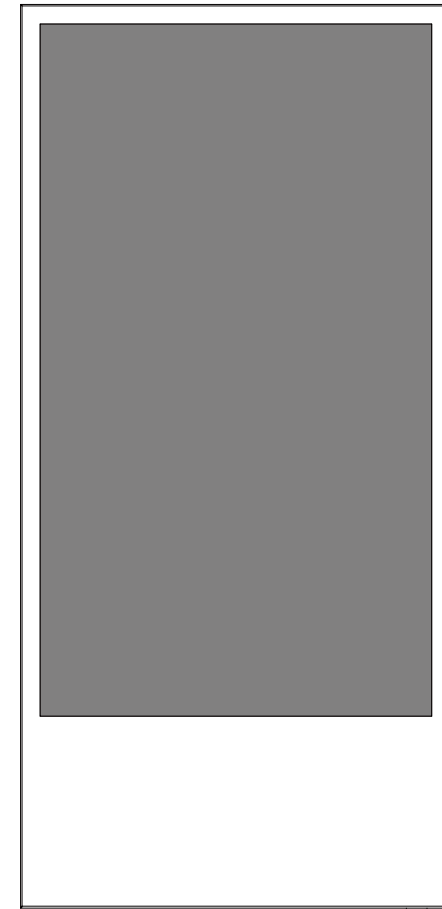
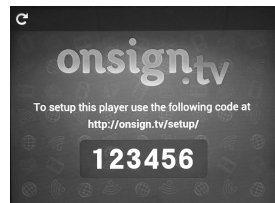

W3202

Light and intelligent Digital Signage Operating Instructions

Product Overview

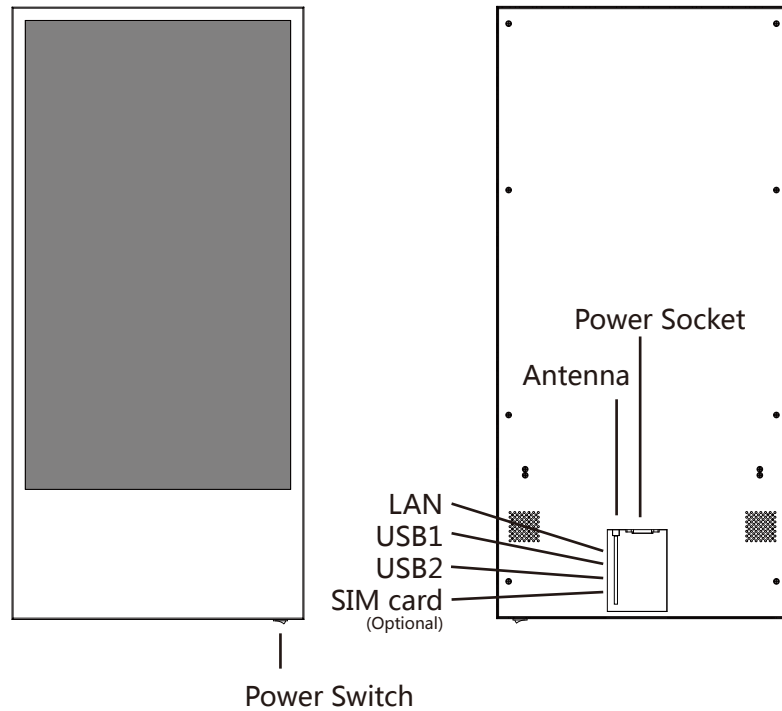

Specifications

Screen size :	32inch	Content format:	
Screen resolution :	768x1366	Picture :	jpg、 bmp、 png、 gif
Brightness :	300cd/m ² (typical)	Video :	AVI、 MPEG2、 MPEG4、 WMV
Constract ratio :	800:1	Audio :	mp3
Dimension :	920x440x35(mm)		(Playback with an Android OS multimedia player)
Weight :	9.6kg		
Internet connect :	LAN / Wi-Fi / 3G (Optional)		

Warning

- ⊘ Do not use any kinds of power supply other than AC 220V, 50/60Hz.
 - Do not fix the signage in an unstable place and position, otherwise it may cause damage dueto falling, or even cause fire.
 - Do not place the signage under strong and direct light, in an environment with high humidity, overheat or much dust, in an environment storing or using flammable and explosive substances, and an environment withcombustible or corrosive gases.
 - Do not use damaged or unfitted power socket. Please make sure the plug fits well the power socket.
 - The plug and power socket should not adhere to dust and metal attachment.
 - The power cord should not be damaged. Any modification of the power cord is strictly prohibited. Keep the power cord away from heat source. Do not pull the power cord when pulling off the plug.
 - Too many parallel plugs in one socket should be prohibited; otherwise it may cause fire due to excessive power dissipation.
 - Keep the signage away from open fire; otherwise it will cause electric shock or even fire.
- ⚠ Do not place any water-filled containers around the signage, to prevent any dripping or splashing of water which may cause electric shock or fire.
 - ⚠ Pull off the power plug when cleaning the signage. Use a soft cloth dipped with water to clean. Do not use industrial chemicals to wash or clean. Prevent foreign matter and water from entering into the machine.
 - Do not rub with a hard object, knocking LCD screen, or liquid crystal display pressed hard twist. Do not rub or knock the LCD with a hard object, or press or twist the LCD screen.
 - In case the LCD breaks and the liquid spilled onto skin, wash immediately with water for 15 minutes and consult your doctor.
 - ⊘ Do not touch the plug with wet hands, otherwise it may cause electric shock.
 - ⚡ When it rains heavily, do not use the signage, especially at the time when there is thunder and lightning together. Unplug the power cords and the antenna plugs promptly, to prevent lightning strike.
 - ⊘ Do not in any way disassemble the signage, or it may cause electric shock or fire. All repairs should be managed by a professional technical staff.

Packing List

Signage Smart Panel

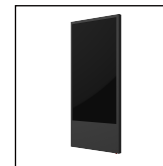

Power cord



Operation manual

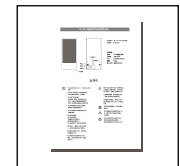

Wall mount(Optional)

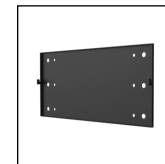

Foldable floor stand(Optional)

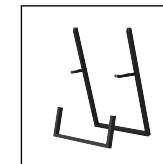

FCC Statement

This equipment has been tested and found to comply with the limits for a Class B digital device, pursuant to Part 15 of the FCC Rules. These limits are designed to provide reasonable protection against harmful interference in a residential installation. This equipment generates uses and can radiate radio frequency energy and, if not installed and used in accordance with the instructions, may cause harmful interference to radio communications. However, there is no guarantee that interference will not occur in a particular installation. If this equipment does cause harmful interference to radio or television reception, which can be determined by turning the equipment off and on, the user is encouraged to try to correct the interference by one or more of the following measures:

- Reorient or relocate the receiving antenna.
- Increase the separation between the equipment and receiver.
- Connect the equipment into an outlet on a circuit different from that to which the receiver is connected.
- Consult the dealer or an experienced radio/TV technician for help.

This device complies with part 15 of the FCC Rules. Operation is subject to the following two conditions:(1) This device may not cause harmful interference, and (2) this device must accept any interference received, including interference that may cause undesired operation.

Changes or modifications not expressly approved by the party responsible for compliance could void the user's authority to operate the equipment.

This equipment should be installed and operated with minimum distance 20cm between the radiator & your body.