



FCC TEST REPORT

FCC ID: 2AHW7-G6

On Behalf of

Guilin Feiyu Technology Incorporated Company

G6 3-Axis Stabilized Handheld Gimbal

Model No.: G6

Prepared for : Guilin Feiyu Technology Incorporated Company
Address : 3rd Floor, B, Guilin Electric Valley, Innovation Building, Information
Industry Park, ChaoYang Road, Qi Xing District, Guilin 541004, China

Prepared By : Shenzhen Alpha Product Testing Co., Ltd.
Address : Building B, East Area of Nanchang Second Industrial Zone,
Gushu 2nd Road, Bao'an District, Shenzhen 518126, P.R. China

Report Number : T1880701 05
Date of Receipt : May 07, 2018
Date of Test : May 07-June 22, 2018
Date of Report : June 22, 2018
Version Number : REV0

TABLE OF CONTENTS

Description	Page
1. Summary of Standards And Results -----	6
1.1. Description of Standards and Results-----	6
2. General Information -----	7
2.1. Description of Device (EUT)-----	7
2.2. Accessories of Device (EUT) -----	8
2.3. Tested Supporting System Details-----	8
2.4. Block Diagram of connection between EUT and simulators-----	8
2.5. Test Mode Description-----	9
2.6. Test Conditions-----	9
2.7. Test Facility -----	10
2.8. Measurement Uncertainty-----	10
2.9. Test Equipment List -----	11
3. Spurious Emission -----	13
3.1. Test Limits -----	13
3.2. Test Procedure-----	13
3.3. Test Setup -----	14
3.4. Test Results -----	15
4. Power line Conducted Emission-----	22
4.1. Test Limits -----	22
4.2. Test Procedure-----	22
4.3. Test Setup -----	22
4.4. Test Results -----	23
5. Conducted Maximum Output Power -----	25
5.1. Test limits -----	25
5.2. Test Procedure-----	25
5.3. Test Setup -----	25
5.4. Test Results -----	25
6. Peak Power Spectral Density -----	27
6.1. Test limits -----	27
6.2. Test Procedure-----	27
6.3. Test Setup -----	27
6.4. Test Results -----	28
7. Bandwidth -----	35
7.1. Test limits -----	35
7.2. Test Procedure-----	35
7.3. Test Setup -----	35
7.4. Test Results -----	35
8. Band Edge Check -----	43
8.1. Test limits -----	43
8.2. Test Procedure-----	43
8.3. Test Setup -----	43
8.4. Test Results -----	43

- 9. Antenna Requirement-----50**
 - 9.1. Standard Requirement ----- 50
 - 9.2. Antenna Connected Construction----- 50
 - 9.3. Results ----- 50
- 10. Test setup photo -----51**
 - 10.1. Photos of Radiated emission----- 51
 - 10.2. Photos of Conducted Emission test ----- 52
- 11. Test setup photo -----53**

TEST REPORT DECLARATION

Applicant : Guilin Feiyu Technology Incorporated Company
 Address : 3rd Floor, B, Guilin Electric Valley, Innovation Building, Information Industry Park, ChaoYang Road, Qi Xing District, Guilin 541004, China
 Manufacturer : Artway Technology International Ltd.
 Address : Guilin Feiyu Technology Incorporated Company
 EUT Description : 3rd Floor, B, Guilin Electric Valley, Innovation Building, Information Industry Park, ChaoYang Road, Qi Xing District, Guilin 541004, China
 (A) Model No. : G6
 (B) Trademark : FeiyuTech

Measurement Standard Used:

FCC Rules and Regulations Part 15 Subpart C Section 15.247: 2016, ANSI C63.10-2013

The device described above is tested by Shenzhen Alpha Product Testing Co., Ltd. to determine the maximum emission levels emanating from the device. The maximum emission levels are compared to the FCC Part 15 Subpart C limits both conducted and radiated emissions. The test results are contained in this test report and Shenzhen Alpha Product Testing Co., Ltd. is assumed of full responsibility for the accuracy and completeness of these tests.

After the test, our opinion is that EUT compliance with the requirement of the above standards.

This report applies to above tested sample only. This report shall not be reproduced in parts without written approval of Shenzhen Alpha Product Testing Co., Ltd.

Tested by (name + signature).....: Reak Yang
 Project Engineer 

Approved by (name + signature).....: Simple Guan
 Project Manager 

Date of issue.....: June 22, 2018

Revision History

Revision	Issue Date	Revisions	Revised By
00	June 22, 2018	Initial released Issue	Simple Guan

1. SUMMARY OF STANDARDS AND RESULTS

1.1. Description of Standards and Results

The EUT have been tested according to the applicable standards as referenced below:

Test Item	Test Requirement	Standards Paragraph	Result
Conducted Emission	FCC PART 15:2016	15.207	P
6dB Bandwidth	FCC PART 15:2016	15.247 (a)(2)	P
Output Power	FCC PART 15:2016	15.247 (b)(3)	P
Radiated Spurious Emission	FCC PART 15:2016	15.247 (c)	P
Conducted Spurious & Band Edge Emission	FCC PART 15:2016	15.247 (d)	P
Power Spectral Density	FCC PART 15:2016	15.247 (e)	P
Radiated Band Edge Emission	FCC PART 15:2016	15.205	P
Antenna Requirement	FCC PART 15:2016	15.203	P
Note:	1. P is an abbreviation for Pass. 2. F is an abbreviation for Fail. 3. N/A is an abbreviation for Not Applicable.		

2. GENERAL INFORMATION

2.1. Description of Device (EUT)

Description	: G6 3-Axis Stabilized Handheld Gimbal
Model Number	: G6
Diff	: N/A
Trademark	: FeiyuTech
Test Voltage	: DC 3.7V from battery and DC 5V From USB Port
Operation frequency	: IEEE 802.11b/g: 2412MHz-2462MHz IEEE 802.11n HT20: 2412MHz-2462MHz IEEE 802.11n HT40: 2422MHz-2452MHz IEEE 802.11b/g:11Channels
Channel No.	: IEEE 802.11n HT20: 11 Channels IEEE 802.11n HT40: 7Channels IEEE 802.11b: DSSS(CCK,DQPSK,DBPSK)
Modulation type	: IEEE 802.11g: OFDM(64QAM, 16QAM, QPSK, BPSK) IEEE 802.11n :OFDM(64QAM, 16QAM, QPSK, BPSK)
Antenna Type	: PCB Antenna, Maximum Gain is 1.68dBi
Software version	: V1.0
Hardware version	: V1.0

2.2. Accessories of Device (EUT)

Power Source : N/A

2.3. Tested Supporting System Details

No.	Description	Manufacturer	Model	Serial Number	Certification or DOC
1	Notebook	ACER	ZQT	N/A	DOC

2.4. Block Diagram of connection between EUT and simulators

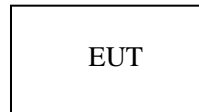

2.5. Test Mode Description

Duty cycle :100% Keeping TX					
Mode	Setting output power (Max)	data rate (Mbps)(see Note)	Channel	Frequency (MHz)	
IEEE 802.11b	8dBm	1	Low :CH1	2412	
		1	Middle: CH6	2437	
		1	High: CH11	2462	
IEEE 802.11g	8 dBm	6	Low :CH1	2412	
		6	Middle: CH6	2437	
		6	High: CH11	2462	
IEEE 802.11 n/HT20 with 2.4G	8 dBm	6.5	Low :CH1	2412	
		6.5	Middle: CH6	2437	
		6.5	High: CH11	2462	
IEEE 802.11 n/HT40 with 2.4G	5 dBm	13.5	Low :CH3	2422	
		13.5	Middle:CH6	2437	
		13.5	High:CH9	2452	
Note: According exploratory test, EUT will have maximum output power in those data rate. so those data rate were used for all test.					
Channel list:					
For IEEE 802.11b/g and IEEE 802.11n/HT20 with 2.4G					
Channel	Frequency (MHz)	Channel	Frequency (MHz)	Channel	Frequency (MHz)
CH1	2412	CH5	2432	CH9	2452
CH2	2417	CH6	2437	CH10	2457
CH3	2422	CH7	2442	CH11	2462
CH4	2427	CH8	2447		
For IEEE 802.11n/HT40 with 2.4G					
Channel	Frequency (MHz)	Channel	Frequency (MHz)	Channel	Frequency (MHz)
CH1	/	CH5	2432	CH9	2452
CH2	/	CH6	2437	/	/
CH3	2422	CH7	2442	/	/
CH4	2427	CH8	2447	/	/

2.6. Test Conditions

Items	Required	Actual
Temperature range:	15-35°C	27°C
Humidity range:	25-75%	56%
Pressure range:	86-106kPa	980kPa

2.7. Test Facility

Shenzhen Alpha Product Testing Co., Ltd
 Building i, No.2, Lixin Road, Fuyong Street, Bao'an District, 518103,
 Shenzhen, Guangdong, China

June 21, 2018 File on Federal Communication Commission
 Registration Number: 293961

July 25, 2017 Certificated by IC
 Registration Number: 12135A

2.8. Measurement Uncertainty

(95% confidence levels, k=2)

Item	Uncertainty
Uncertainty for Power point Conducted Emissions Test	2.42dB
Uncertainty for Radiation Emission test in 3m chamber (below 30MHz)	2.13 dB(Polarize: V)
	2.57dB(Polarize: H)
Uncertainty for Radiation Emission test in 3m chamber (30MHz to 1GHz)	3.54dB(Polarize: V)
	4.1dB(Polarize: H)
Uncertainty for Radiation Emission test in 3m chamber (1GHz to 25GHz)	2.08dB(Polarize: H)
	2.56dB(Polarize: V)
Uncertainty for radio frequency	1×10^{-9}
Uncertainty for conducted RF Power	0.65dB
Uncertainty for temperature	0.2°C
Uncertainty for humidity	1%
Uncertainty for DC and low frequency voltages	0.06%

2.9. Test Equipment List

Equipment	Manufacture	Model No.	Serial No.	Last cal.	Cal Interval
3m Semi-Anechoic	ETS-LINDGR EN	N/A	SEL0017	2017.09.22	1Year
Spectrum analyzer	Agilent	E4407B	MY46185649	2017.09.22	1Year
Receiver	R&S	ESCI	1166.5950K03-101 1	2017.09.22	1Year
Receiver	R&S	ESCI	101202	2017.09.22	1Year
Bilog Antenna	Schwarzbeck	VULB 9168	VULB9168-438	2016.09.30	2Year
Horn Antenna	EMCO	3115	640201028-06	2016.09.30	2Year
Active Loop Antenna	Beijing Daze	ZN30900A	SEL0097	2016.09.30	2Year
Cable	Resenberger	N/A	No.1	2017.09.22	1Year
Cable	SCHWARZBE CK	N/A	No.2	2017.09.22	1Year
Cable	SCHWARZBE CK	N/A	No.3	2017.09.22	1Year
Pre-amplifier	Schwarzbeck	BBV9743	9743-019	2017.09.22	1Year
Pre-amplifier	R&S	AFS33-1800265 0-30-8P-44	SEL0080	2017.09.22	1Year
Temperature controller	Terchy	MHQ	120	2017.09.22	1Year
Power divider	Anritsu	K240C	020346	2017.09.22	1 Year
Signal Generator	HP	83732B	VS3449051	2017.09.22	1 Year
Power Meter	Anritsu	ML2487A	6K00001491	2017.09.22	1Year

Power sensor	Anritsu	ML2491A	32516	2017.09.22	1Year
L.I.S.N.#1	Schwarzbeck	NSLK8126	8126466	2017.09.22	1Year
L.I.S.N.#2	ROHDE&SCH WARZ	ENV216	101043	2017.09.22	1 Year
20db Attenuator	ICPROBING	IATS1	82347	2017.09.22	1 Year
Horn Antenna	SCHWARZBE CK	BBHA 9170	BBHA 9170294	2017.02.22	2 Year

3. SPURIOUS EMISSION

3.1. Test Limits

Frequencies (MHz)	Field Strength (micorvolts/meter)	Measurement Distance (meters)
0.009~0.490	2400/F(KHz)	300
0.490~1.705	24000/F(KHz)	30
1.705~30.0	30	30
30~88	100	3
88~216	150	3
216~960	200	3
Above 960	500	3

Harmonic emissions limits comply with below 54 dBuV/m at 3m. Other emissions radiated outside of the specified frequency bands, except for harmonics, shall be attenuated by at least 50 dB below the level of the fundamental or comply with the radiated emissions limits specified in section 15.209(a) limit in the table below has to be followed.

NOTE:

- a) The tighter limit applies at the band edges.
- b) Emission Level(dB uV/m)=20log Emission Level(Uv/m)

3.2. Test Procedure

The measuring distance of 3m shall be used for measurements at frequency up to 1GH and above 1GHz, The EUT was placed on a rotating 0.8 m high above ground for below 1GHz and 1.5m high for above1GHz testing, The table was rotated 360 degrees to determine the position of the highest radiation

The Test antenna shall vary between 1m and 4m,Both Horizontal and Vertical antenna are set of make measurement.

The initial step in collecting conducted emission data is a spectrum analyzer Peak detector mode pre-scanning the measurement frequency range. Significant Peaks are then marked. and then Qusia Peak Detector mode premeasured

If Peak value comply with QP limit Below 1GHz.The EUT deemed to comply with QP limit. But the Peak value and average value both need to comply with applicable limit above 1GHz.

For the actual test configuration, please see the test setup photo.

3.3. Test Setup

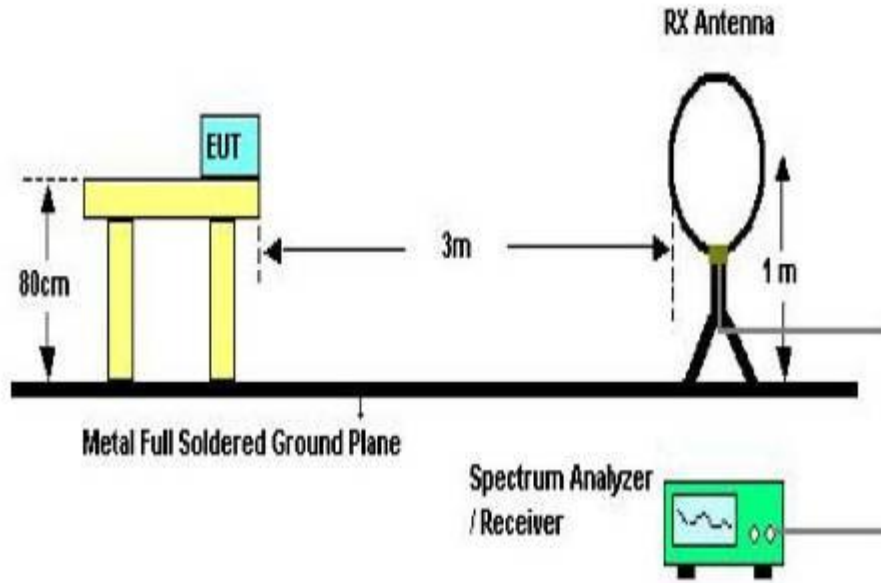

Below 30MHz Test Setup

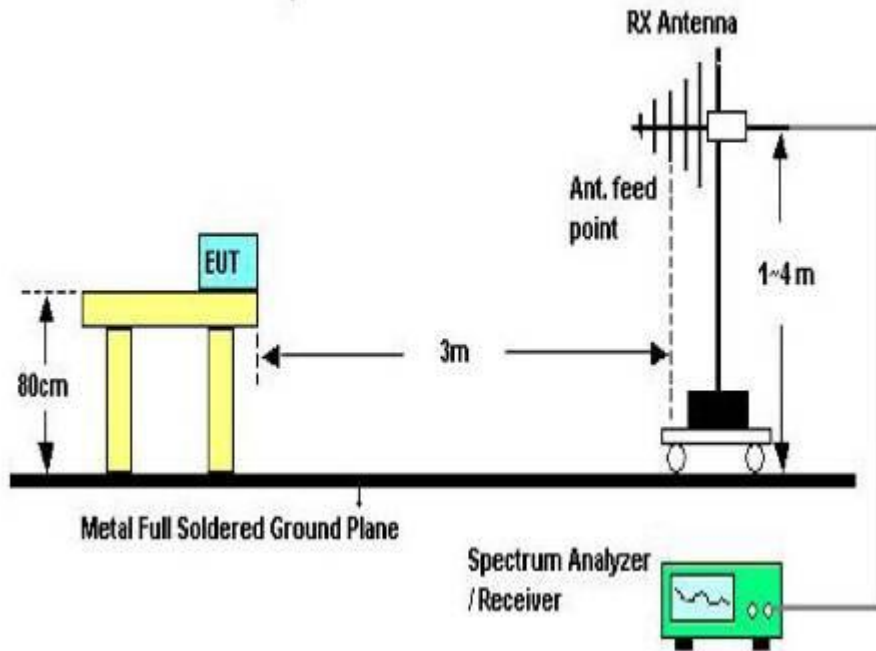

Above 30MHz Test Setup

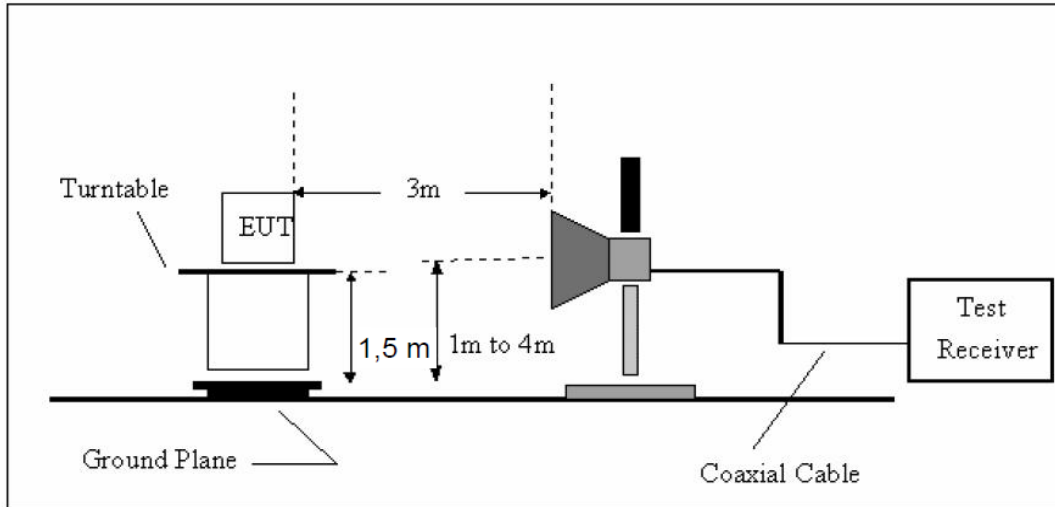

Above 1GHz Test Setup

3.4. Test Results

Test Condition

Continual Transmitting in maximum power.

9KHz~150KHz	RBW200Hz	VBW1KHz
150KHz~30MHz	RBW9KHz	VBW 30KHz
30MHz~1GHz	RBW120KHz	VBW 300KHz
Above1GHz	RBW1MHz	VBW 3MHz

We have scanned the 10th harmonic from 9 kHz to the EUT.

Detailed information please see the following page.

From 9KHz to 30MHz: Conclusion: PASS

Note:1.The amplitude of spurious emissions which are attenuated by more than 20dB below the permissible value has no need to be reported.

2.Only show the test data of the worst Channel in this report.

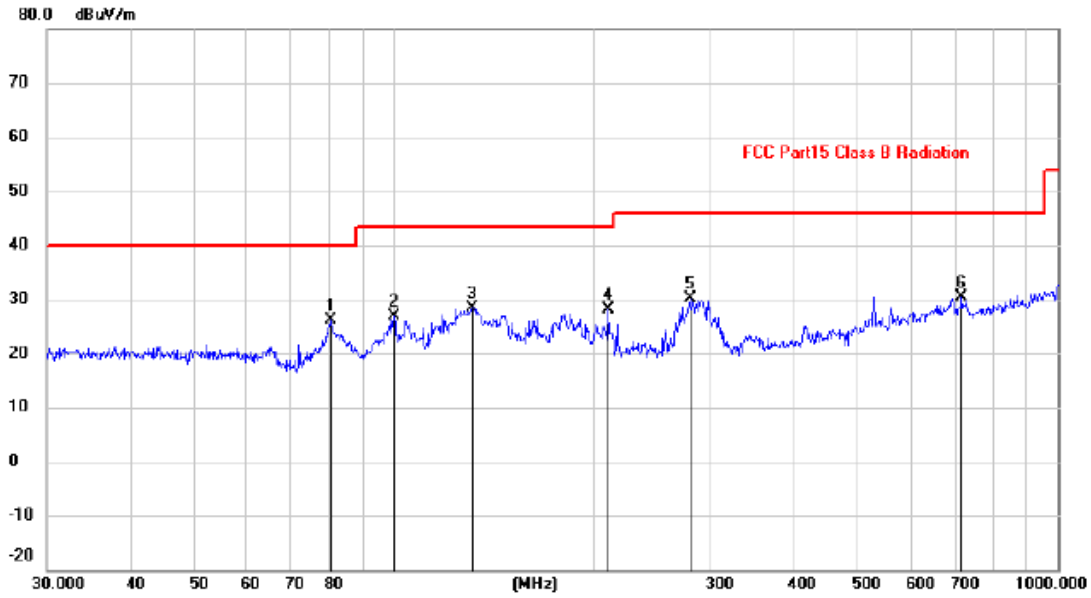

No.	Mk.	Freq.	Reading Level	Correct Factor	Measurement	Limit	Margin	Antenna Height	Table Degree	
		MHz	dBuV	dB	dBuV/m	dBuV/m	dB	cm	degree	Comment
1	*	80.6440	16.67	9.47	26.14	40.00	-13.86			peak
2		99.8777	16.26	10.60	26.86	43.50	-16.64			peak
3		130.8369	15.06	13.28	28.34	43.50	-15.16			peak
4		210.0482	17.43	10.69	28.12	43.50	-15.38			peak
5		279.0436	17.29	12.95	30.24	46.00	-15.76			peak
6		716.6820	9.43	20.96	30.39	46.00	-15.61			peak

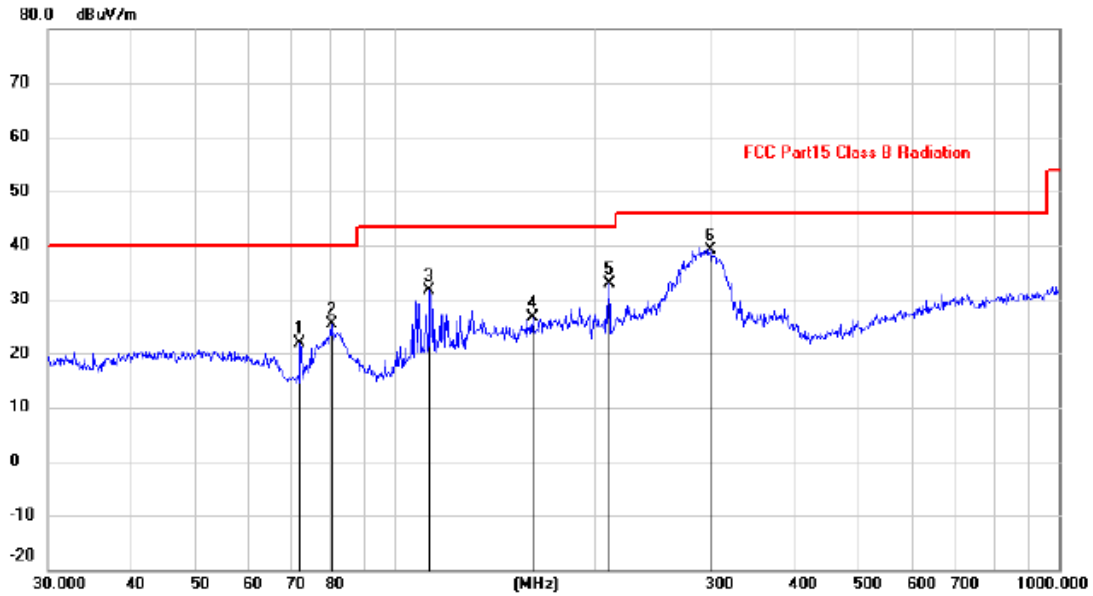

No.	Mk.	Freq.	Reading Level	Correct Factor	Measurement	Limit	Margin	Antenna Height	Table Degree
		MHz	dBuV	dB	dBuV/m	dBuV/m	dB	cm	degree
1		71.8319	11.06	10.70	21.76	40.00	-18.24	peak	
2		80.3617	15.96	9.45	25.41	40.00	-14.59	peak	
3		112.5241	19.79	11.78	31.57	43.50	-11.93	peak	
4		160.9088	12.12	14.50	26.62	43.50	-16.88	peak	
5		210.0482	22.25	10.69	32.94	43.50	-10.56	peak	
6	*	298.2681	25.76	13.42	39.18	46.00	-6.82	peak	

Remark: Above is below 1GHz test data. This report only shall the worst case mode for TX IEEE 802.11b 2437MHz.

From 1G-25GHz

Test Mode: IEEE 802.11b TX Low									
Freq (MHz)	Read Level (dBuV/m)	Polar (H/V)	Antenna Factor (dB/m)	Cable loss(dB)	Amp Factor (dB)	Result (dBuV/m)	Limit (dBuV/m)	Margin (dB)	Remark
4824	40.41	V	33.95	10.18	34.26	50.28	74	23.72	PK
4824	31.44	V	33.95	10.18	34.26	41.31	54	12.69	AV
7236									
9648									
4824	39.24	H	33.95	10.18	34.26	49.11	74	24.89	PK
4824	31.58	H	33.95	10.18	34.26	41.45	54	12.55	AV
7236									
9648									
Test Mode: IEEE 802.11b TX Mid									
4874	41.37	V	33.93	10.2	34.29	51.21	74	22.79	PK
4874	32.04	V	33.93	10.2	34.29	41.88	54	12.12	AV
7311									
9748									
4874	41.32	H	33.93	10.2	34.29	51.16	74	22.84	PK
4874	33.06	H	33.93	10.2	34.29	42.90	54	11.10	AV
7311									
9748									
Test Mode: IEEE 802.11b TX High									
4924	42.41	V	33.98	10.22	34.25	52.36	74	21.64	PK
4924	33.07	V	33.98	10.22	34.25	43.02	54	10.98	AV
7386									
9848									
4924	42.53	H	33.98	10.22	34.25	52.48	74	21.52	PK
4924	32.11	H	33.98	10.22	34.25	42.06	54	11.94	AV
7386									
9848									
Note:									
1, Result = Read level + Antenna factor + cable loss-Amp factor									
2, All the other emissions not reported were too low to read and deemed to comply with FCC limit.									

Test Mode: IEEE 802.11g TX Low									
Freq (MHz)	Read Level (dBuV/m)	Polar (H/V)	Antenna Factor (dB/m)	Cable loss(dB)	Amp Factor (dB)	Result (dBuV/m)	Limit (dBuV/m)	Margin (dB)	Remark
4824	37.69	V	33.95	10.18	34.26	47.56	74	26.44	PK
4824	31.78	V	33.95	10.18	34.26	41.65	54	12.35	AV
7236	/								
9648	/								
4824	39.57	H	33.95	10.18	34.26	49.44	74	24.56	PK
4824	31.08	H	33.95	10.18	34.26	40.95	54	13.05	AV
7236									
9648									
Test Mode: IEEE 802.11g TX Mid									
4874	41.36	V	33.93	10.2	34.29	51.20	74	22.80	PK
4874	31.88	V	33.93	10.2	34.29	41.72	54	12.28	AV
7311	/								
9748	/								
4874	41.41	H	33.93	10.2	34.29	51.25	74	22.75	PK
4874	32.76	H	33.93	10.2	34.29	42.60	54	11.40	AV
7311									
9748									
Test Mode: IEEE 802.11g TX High									
4924	41.68	V	33.98	10.22	34.25	51.63	74	22.37	PK
4924	32.35	V	33.98	10.22	34.25	42.30	54	11.70	AV
7386	/								
9848	/								
4924	42.38	H	33.98	10.22	34.25	52.33	74	21.67	PK
4924	32.92	H	33.98	10.22	34.25	42.87	54	11.13	AV
7386									
9848									
Note:									
1, Result = Read level + Antenna factor + cable loss-Amp factor									
2, All the other emissions not reported were too low to read and deemed to comply with FCC limit.									

Test Mode:IEEE 802.11n HT20 TX Low									
Freq (MHz)	Read Level (dBuV/m)	Polar (H/V)	Antenna Factor (dB/m)	Cable loss(dB)	Amp Factor (dB)	Result (dBuV/m)	Limit (dBuV/m)	Margin (dB)	Remark
4824	40.25	V	33.95	10.18	34.26	50.12	74	23.88	PK
4824	31.75	V	33.95	10.18	34.26	41.62	54	12.38	AV
7236	/								
9648	/								
4824	39.44	H	33.95	10.18	34.26	49.31	74	24.69	PK
4824	31.27	H	33.95	10.18	34.26	41.14	54	12.86	AV
7236									
9648									
Test Mode:IEEE 802.11n HT20 TX Mid									
4874	41.14	V	33.93	10.2	34.29	50.98	74	23.02	PK
4874	31.69	V	33.93	10.2	34.29	41.53	54	12.47	AV
7311	/								
9748	/								
4874	41.10	H	33.93	10.2	34.29	50.94	74	23.06	PK
4874	32.82	H	33.93	10.2	34.29	42.66	54	11.34	AV
7311									
9748									
Test Mode:IEEE 802.11n HT20 TX High									
4924	42.18	V	33.98	10.22	34.25	52.13	74	21.87	PK
4924	32.84	V	33.98	10.22	34.25	42.79	54	11.21	AV
7386	/								
9848	/								
4924	42.60	H	33.98	10.22	34.25	52.55	74	21.45	PK
4924	32.31	H	33.98	10.22	34.25	42.26	54	11.74	AV
7386									
9848									
Note:									
1, Result = Read level + Antenna factor + cable loss-Amp factor									
2, All the other emissions not reported were too low to read and deemed to comply with FCC limit.									

Test Mode:IEEE 802.11n HT40 TX Low									
Freq (MHz)	Read Level (dBuV/m)	Polar (H/V)	Antenna Factor (dB/m)	Cable loss(dB)	Amp Factor (dB)	Result (dBuV/m)	Limit (dBuV/m)	Margin (dB)	Remark
4844	39.55	V	33.95	10.18	34.26	49.42	74	24.58	PK
4844	32.07	V	33.95	10.18	34.26	41.94	54	12.06	AV
7266	/								
9688	/								
4844	39.57	H	33.95	10.18	34.26	49.44	74	24.56	PK
4844	30.74	H	33.95	10.18	34.26	40.61	54	13.39	AV
7266									
9688									
Test Mode:IEEE 802.11n HT40 TX Mid									
4874	41.47	V	33.93	10.2	34.29	51.31	74	22.69	PK
4874	31.92	V	33.93	10.2	34.29	41.76	54	12.24	AV
7311	/								
9748	/								
4874	40.80	H	33.93	10.2	34.29	50.64	74	23.36	PK
4874	32.52	H	33.93	10.2	34.29	42.36	54	11.64	AV
7311									
9748									
Test Mode:IEEE 802.11n HT40 TX High									
4904	42.10	V	33.98	10.22	34.25	52.05	74	21.95	PK
4904	32.47	V	33.98	10.22	34.25	42.42	54	11.58	AV
7356	/								
9808	/								
4904	42.47	H	33.98	10.22	34.25	52.42	74	21.58	PK
4904	32.47	H	33.98	10.22	34.25	42.42	54	11.58	AV
7356									
9808									
Note:									
1, Result = Read level + Antenna factor + cable loss-Amp factor									
2, All the other emissions not reported were too low to read and deemed to comply with FCC limit.									

4. POWER LINE CONDUCTED EMISSION

4.1. Test Limits

Frequency MHz	Limits dB(μ V)	
	Quasi-peak Level	Average Level
0.15 -0.50	66 -56*	56 - 46*
0.50 -5.00	56	46
5.00 -30.00	60	50

- Notes: 1. *Decreasing linearly with logarithm of frequency.
 2. The lower limit shall apply at the transition frequencies.
 3. The limit decreases in line with the logarithm of the frequency in the rang of 0.15 to 0.50 MHz.

4.2. Test Procedure

The EUT is put on the plane 0.8m high above the ground by insulating support and is connected to the power mains through a line impedance stabilization network (L.I.S.N.). This provides a 50ohm coupling impedance for the EUT system. Please refer the block diagram of the test setup and photographs. Both sides of AC lines are checked to find out the maximum conducted emission. In order to find the maximum emission levels, the relative positions of equipment and all of the interface cables shall be changed according to ANSI C63.10:2013 on Conducted Emission Measurement.

The bandwidth of test receiver is set at 9 kHz.

4.3. Test Setup

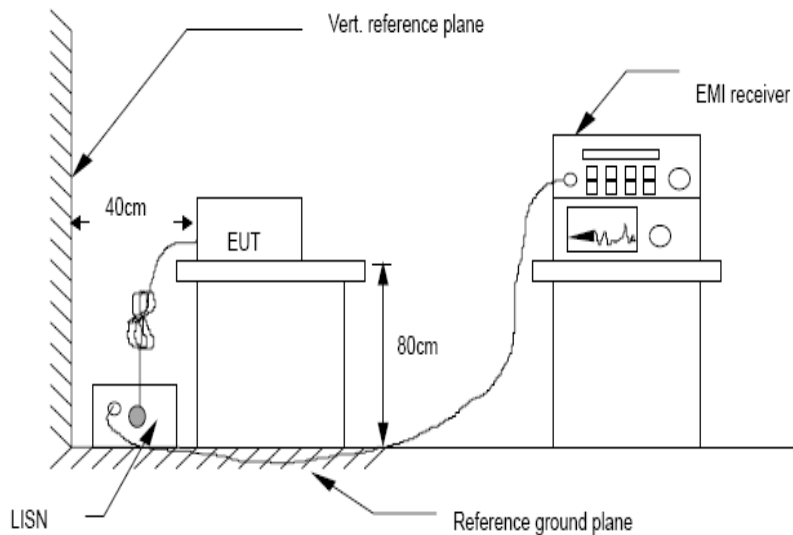

4.4. Test Results

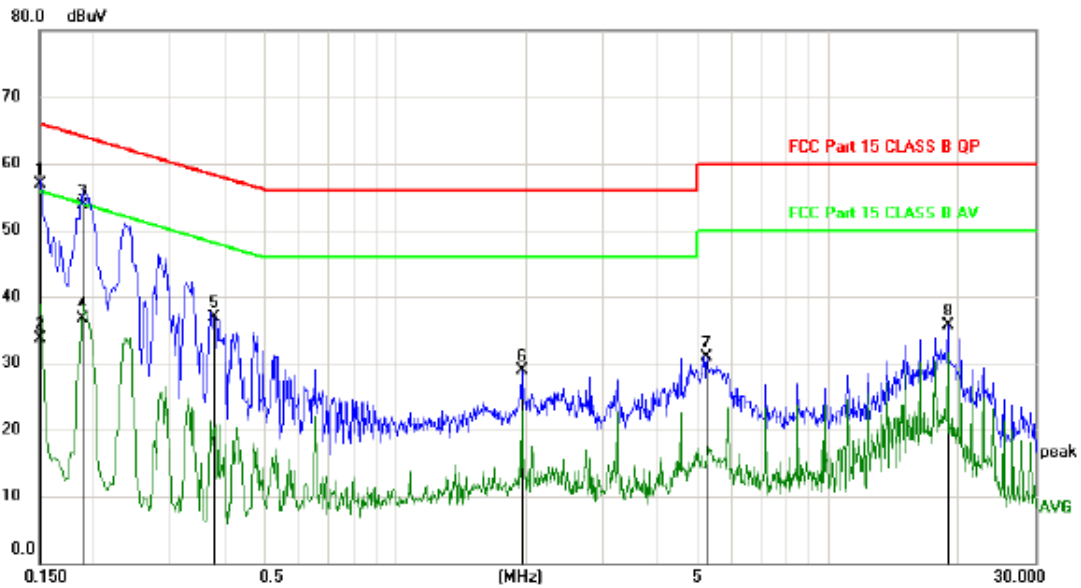

No.	Mk.	Freq. MHz	Reading Level dBuV	Correct Factor dB	Measure- ment dBuV	Limit dBuV	Margin dB	Detector	Comment
1	*	0.1500	47.18	9.73	56.91	66.00	-9.09	QP	
2		0.1500	23.97	9.73	33.70	56.00	-22.30	AVG	
3		0.1890	43.91	9.74	53.65	64.08	-10.43	QP	
4		0.1890	26.91	9.74	36.65	54.08	-17.43	AVG	
5		0.3810	27.14	9.77	36.91	58.26	-21.35	peak	
6		1.9530	19.07	9.92	28.99	56.00	-27.01	peak	
7		5.2320	20.80	10.20	31.00	60.00	-29.00	peak	
8		18.8730	25.32	10.47	35.79	60.00	-24.21	peak	

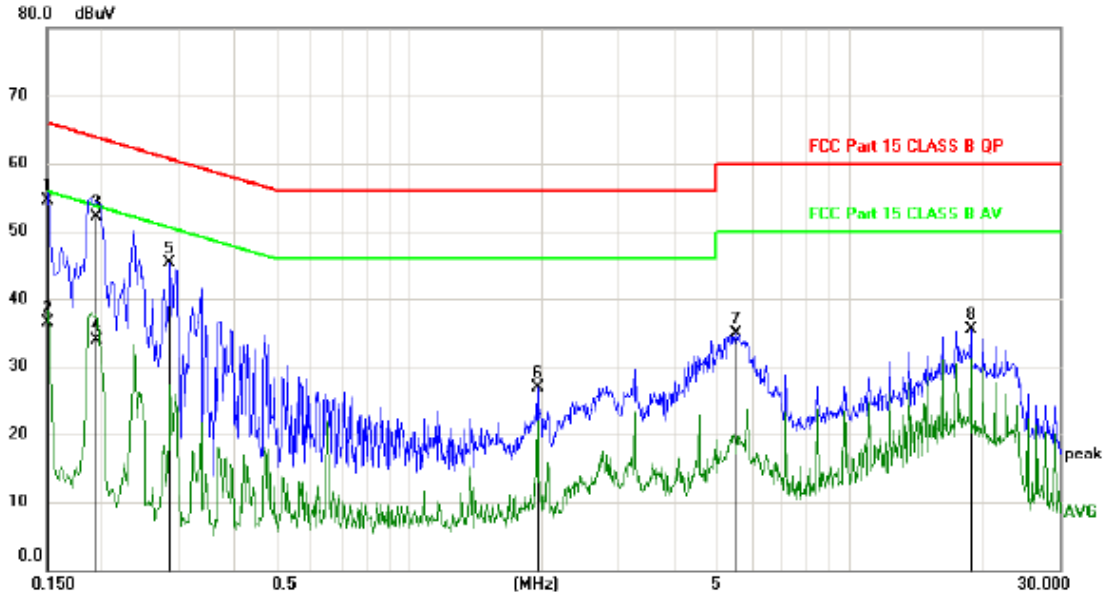

No.	Mk.	Freq. MHz	Reading Level dBuV	Correct Factor dB	Measure- ment dBuV	Limit dBuV	Margin dB	Detector	Comment
1	*	0.1500	44.87	9.73	54.60	66.00	-11.40	QP	
2		0.1500	26.70	9.73	36.43	56.00	-19.57	AVG	
3		0.1949	42.34	9.74	52.08	63.83	-11.75	QP	
4		0.1949	24.24	9.74	33.98	53.83	-19.85	AVG	
5		0.2850	35.48	9.76	45.24	60.67	-15.43	peak	
6		1.9500	16.90	9.92	26.82	56.00	-29.18	peak	
7		5.5260	24.62	10.21	34.83	60.00	-25.17	peak	
8		18.8580	25.01	10.47	35.48	60.00	-24.52	peak	

Remark: All modes and channels have been tested and only listed WiFi link mode that is worst data

5. CONDUCTED MAXIMUM OUTPUT POWER

5.1. Test limits

Please refer section 15.247.

Regulation 15.247(b) The limit of Maximum Peak Output Power Measurement is 1 W(30dBm)

5.2. Test Procedure

Details see the KDB558074 D01 Meas Guidance V04

5.2.1 Place the EUT on the table and set it in transmitting mode.

5.2.2 Connected the EUT's antenna port to peak power meter by 20dB attenuator.

5.2.3 Measure out each mode and each bands peak output power of EUT.

Note: The cable loss and attenuator loss were offset into measure device as amplitude offset.

5.3. Test Setup

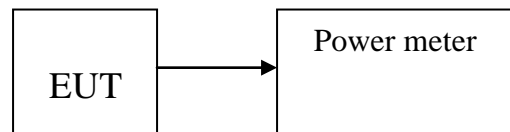

5.4. Test Results

PASS

Detailed information please see the following page.

Mode	Frequency (MHz)	Ant Port	PK Output power(dBm)		Limit (dBm)	Margin (dB)
IEEE 802.11 b	CH1: 2412	1	7.435	7.435	30	22.565
		/	/			
	CH6: 2437	1	6.223	6.223	30	23.777
		/	/			
	CH11: 2462	1	6.073	6.073	30	23.927
		/	/			
IEEE 802.11 g	CH1: 2412	1	6.538	6.538	30	23.462
		/	/			
	CH6: 2437	1	6.682	6.682	30	23.318
		/	/			
	CH11: 2462	1	6.357	6.357	30	23.643
		/	/			
IEEE 802.11 n/HT20 with 2.4G	CH1: 2412	1	6.042	6.042	30	23.958
		/	/			
	CH6: 2437	1	6.361	6.361	30	23.639
		/	/			
	CH11: 2462	1	6.647	6.647	30	23.353
		/	/			
IEEE 802.11 n/HT40 with 2.4G	CH1: 2422	1	3.415	3.415	30	26.595
		/	/			
	CH4: 2437	1	3.204	3.204	30	26.796
		/	/			
	CH7: 2452	1	3.525	3.525	30	26.475
		/	/			
Conclusion: PASS						

6. PEAK POWER SPECTRAL DENSITY

6.1. Test limits

6.1.1 Please refer section 15.247.

6.1.2 For direct sequence systems, the peak power spectral density conducted from the intentional radiator to the antenna shall not be greater than 8dBm in any 3kHz band during any time interval of continuous transmission.

6.1.3 The direct sequence operating of the hybrid system, with the frequency hopping operation turned off, shall comply with the power density requirements of paragraph (d) of this section.

6.2. Test Procedure

Details see the KDB558074 D01 Meas Guidance V04

6.2.1 Place the EUT on the table and set it in transmitting mode.

6.2.2 Remove the antenna from the EUT and then connect a low loss RF cable from the antenna port to the spectrum analyzer.

6.2.3 Set the spectrum analyzer as $RBW = 3\text{kHz}$ (Set the RBW to: $3\text{ kHz} \leq RBW \leq 100\text{ kHz}$.), $VBW = 10\text{kHz}$ (Set the $VBW \geq 3 \times RBW$), $\text{span} = 1.5 \times \text{DTS bandwidth}$., detail see the test plot.

6.2.4 Record the max reading.

6.2.5 Repeat the above procedure until the measurements for all frequencies are completed.

6.3. Test Setup

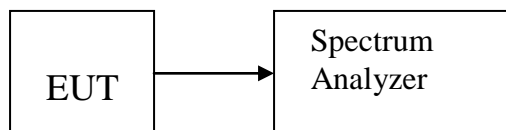

6.4. Test Results

Mode	Frequency (MHz)	Ant Port	PK Output power(dBm)		Limit (dBm)	Result
IEEE 802.11 b	CH1: 2412	1	-7.373	-7.373	8	PASS
		/	/			
	CH6: 2437	1	-9.787	-9.787	8	PASS
		/	/			
	CH11: 2462	1	-20.335	-20.335	8	PASS
		/	/			
IEEE 802.11 g	CH1: 2412	1	-11.068	-11.068	8	PASS
		/	/			
	CH6: 2437	1	-12.748	-12.748	8	PASS
		/	/			
	CH11: 2462	1	-23.461	-23.461	8	PASS
		/	/			
IEEE 802.11 n/HT20 with 2.4G	CH1: 2412	1	-11.078	-11.078	8	PASS
		/	/			
	CH6: 2437	1	-13.681	-13.681	8	PASS
		/	/			
	CH11: 2462	1	-23.263	-23.263	8	PASS
		/	/			
IEEE 802.11 n/HT40 with 2.4G	CH1: 2422	1	-14.853	-14.853	8	PASS
		/	/			
	CH4: 2437	1	-15.737	-15.737	8	PASS
		/	/			
	CH7: 2452	1	-16.716	-16.716	8	PASS
		/	/			
Conclusion: PASS						

IEEE 802.11b :
CH Low :

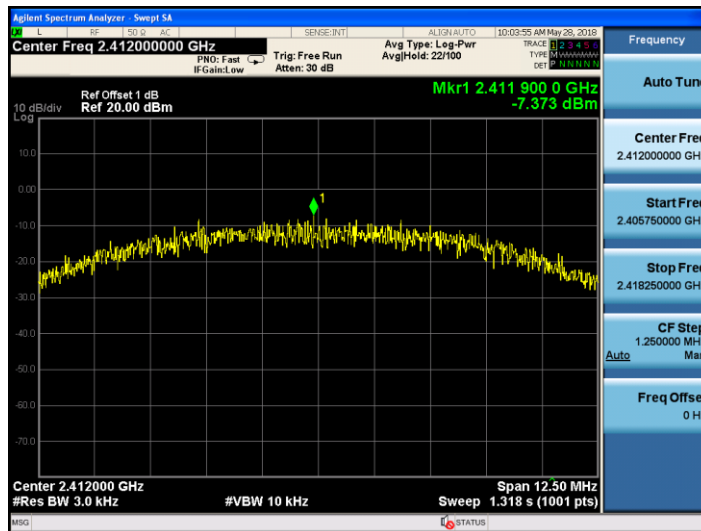

CH Mid:

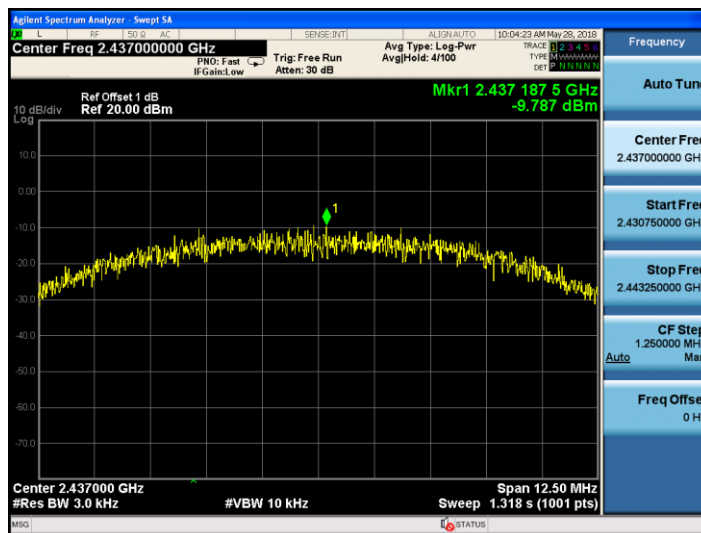

CH Hig:

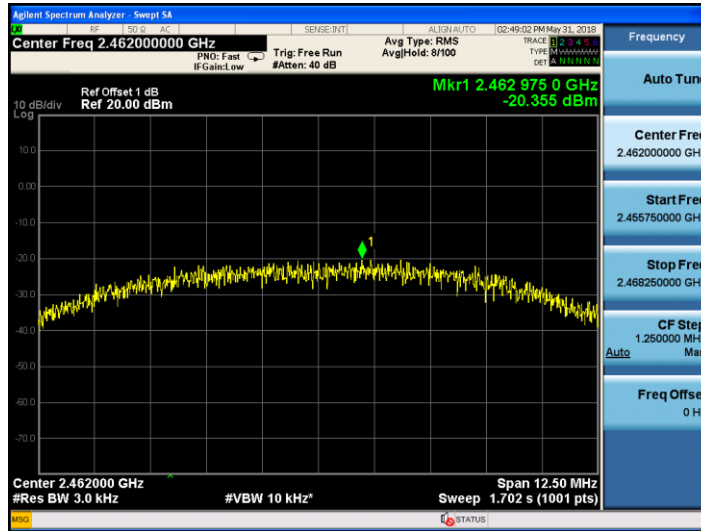

IEEE 802.11g :
CH Low

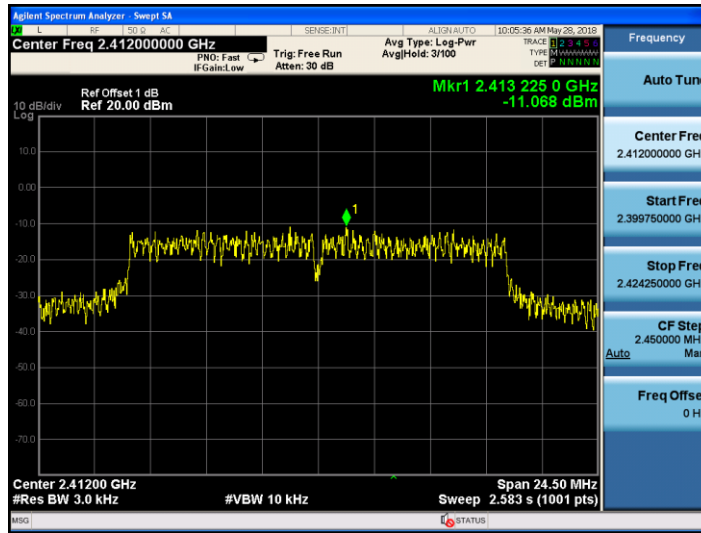

CH Mid:

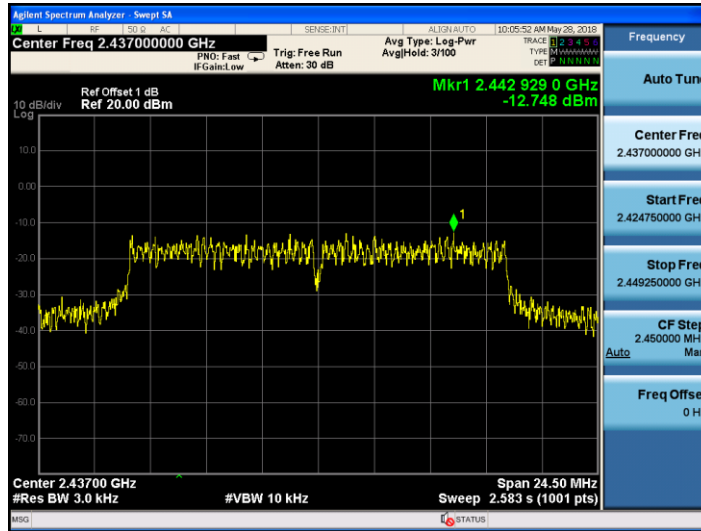

CH Hig:

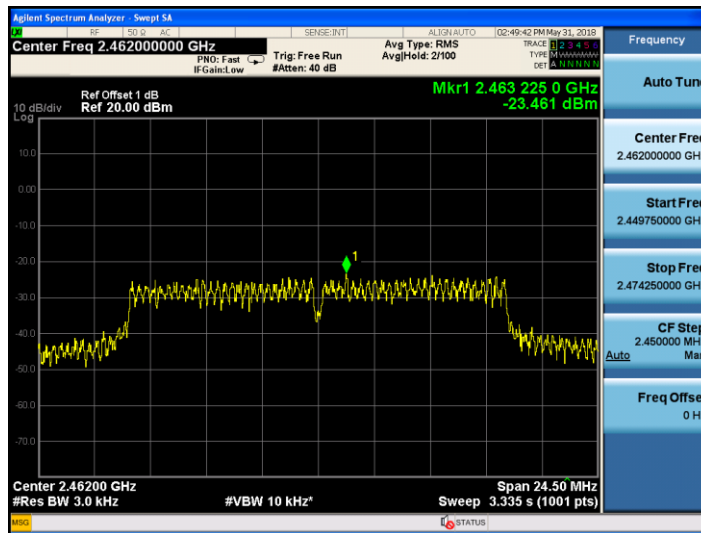

IEEE 802.11n HT20 :
CH Low :

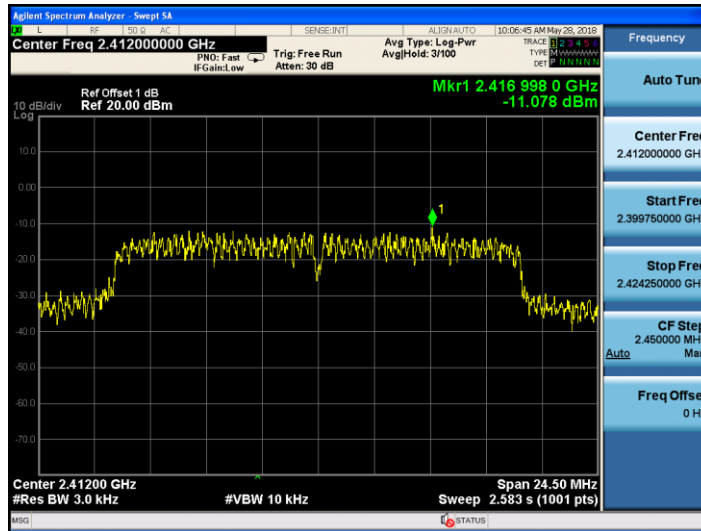

CH Mid:

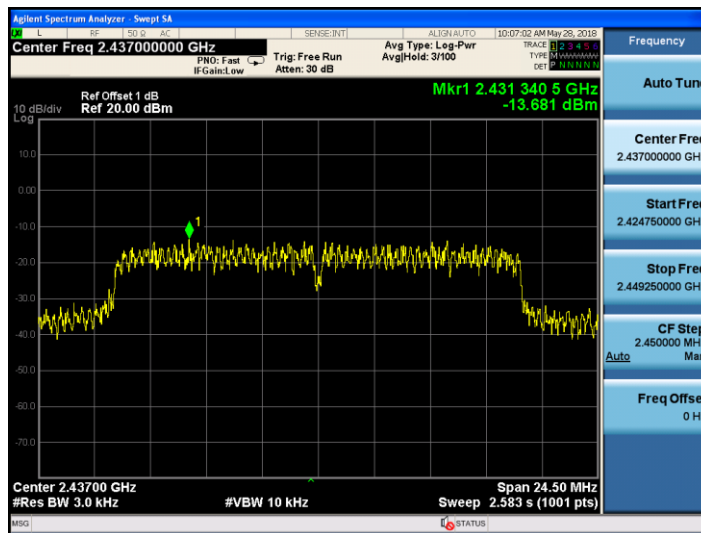

CH High:

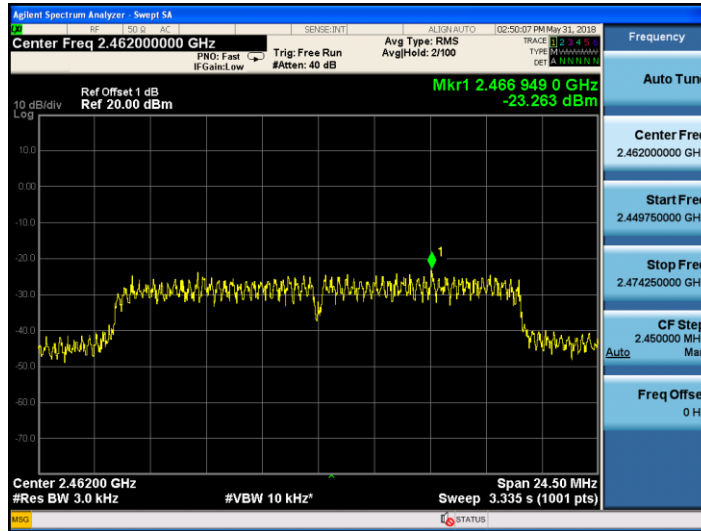

IEEE 802.11n HT40 :
CH Low :

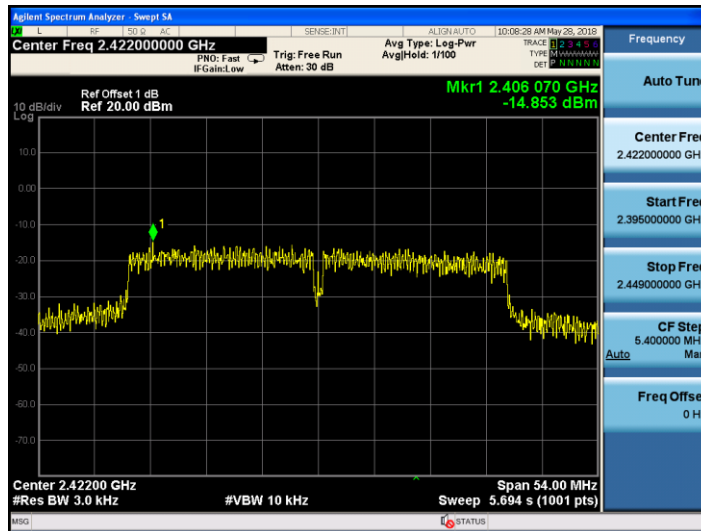

CH Mid:

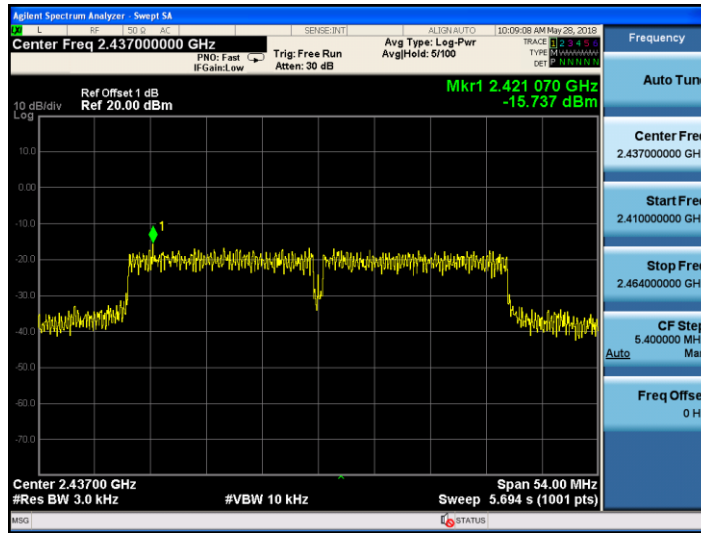

CH High:

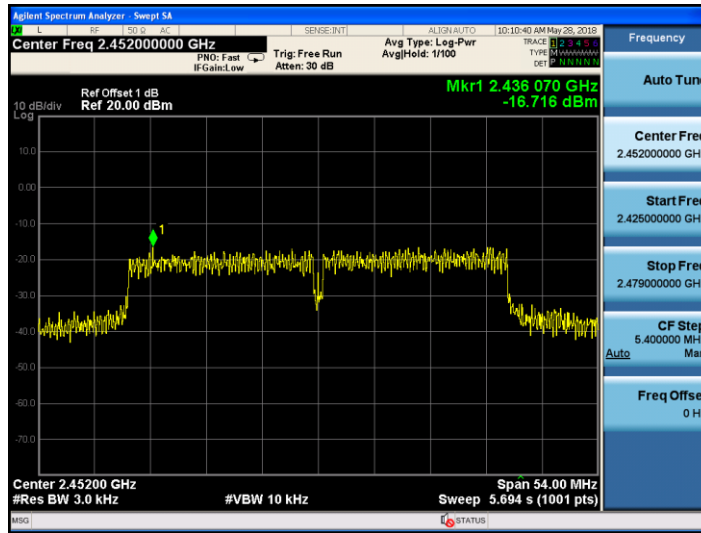

7. BANDWIDTH

7.1. Test limits

Please refer section 15.247

For direct sequence systems, the minimum 6dB bandwidth shall be at least 500 kHz.

7.2. Test Procedure

Details see the KDB558074 D01 Meas Guidance V04

- a) The bandwidth is measured at an amplitude level reduced 20dB from the reference level. The reference level is the level of the highest amplitude signal observed from the transmitter at the fundamental frequency. Once the reference level is established, the equipment is conditioned with typical modulating signal to produce the worst-case (i.e. the widest) bandwidth.
- b) The test receiver set $RBW = 100\text{kHz}$, $VBW \geq 3 * RBW = 300\text{kHz}$, Peak Detector, Sweep time set auto, detail see the test plot.

7.3. Test Setup

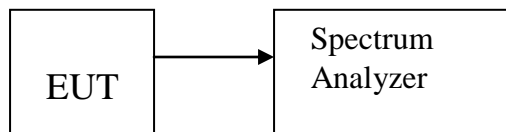

7.4. Test Results

Channel	Frequency (MHz)	6dB Bandwidth (MHz)	99% Occupied Bandwidth (MHz)	Limit (MHz)	Result
IEEE 802.11b:					
Low	2412	7.566	11.574	0.5	PASS
Mid	2437	8.777	11.310	0.5	PASS
High	2462	8.762	11.234	0.5	PASS
IEEE 802.11g					
Low	2412	15.71	17.764	0.5	PASS
Mid	2437	15.73	16.493	0.5	PASS
High	2462	15.15	16.140	0.5	PASS
IEEE 802.11n/HT20					
Low	2412	15.63	17.711	0.5	PASS
Mid	2437	15.94	17.435	0.5	PASS
High	2462	16.29	17.330	0.5	PASS
IEEE 802.11n/HT40					
Low	2422	35.22	36.612	0.5	PASS
Mid	2437	35.53	36.328	0.5	PASS
High	2452	35.51	36.302	0.5	PASS

IEEE 802.11b:
CH Low :



CH Mid :

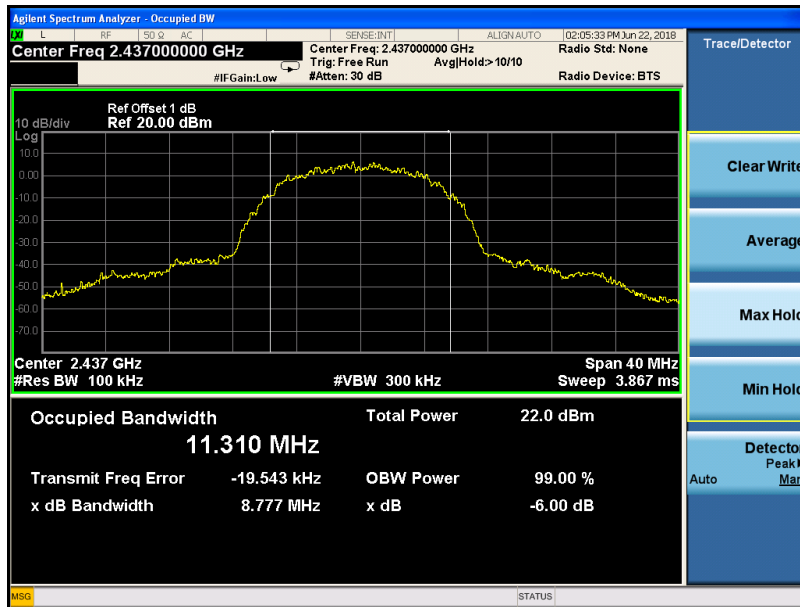

CH High :

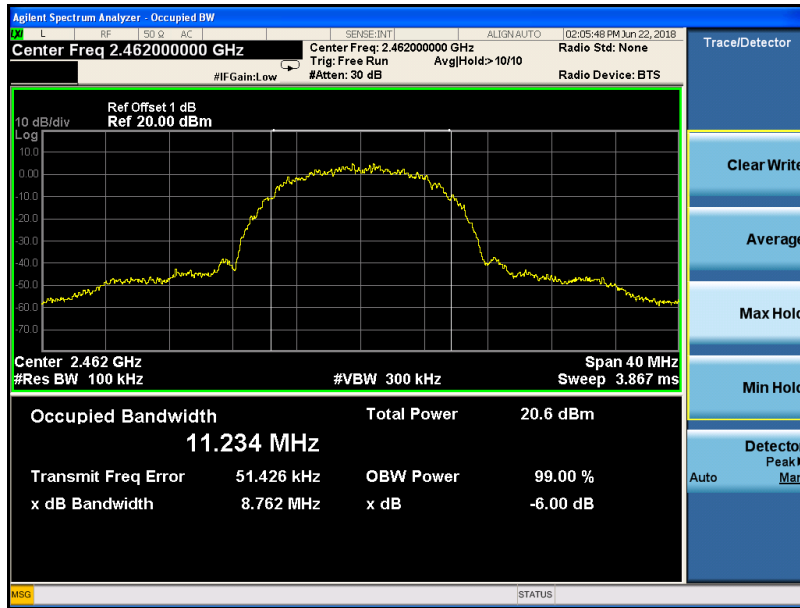

IEEE 802.11g:
CH Low :

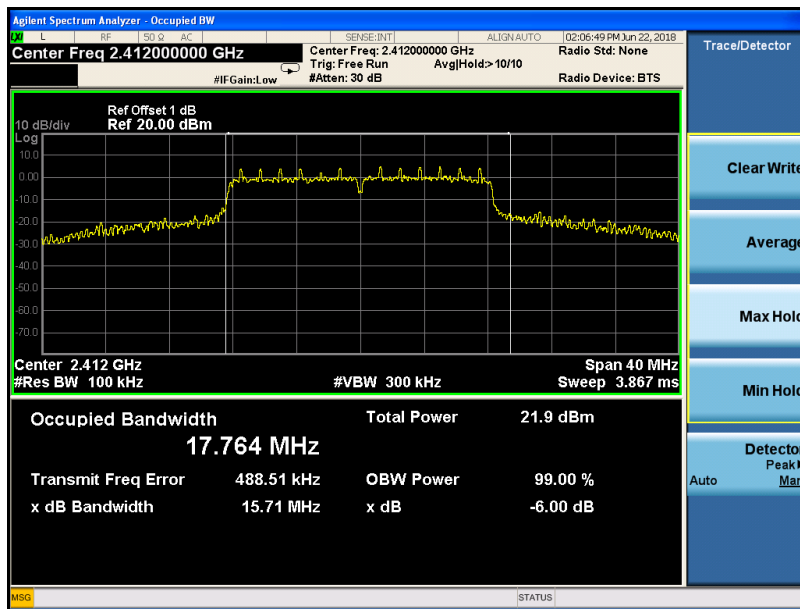

CH Mid:

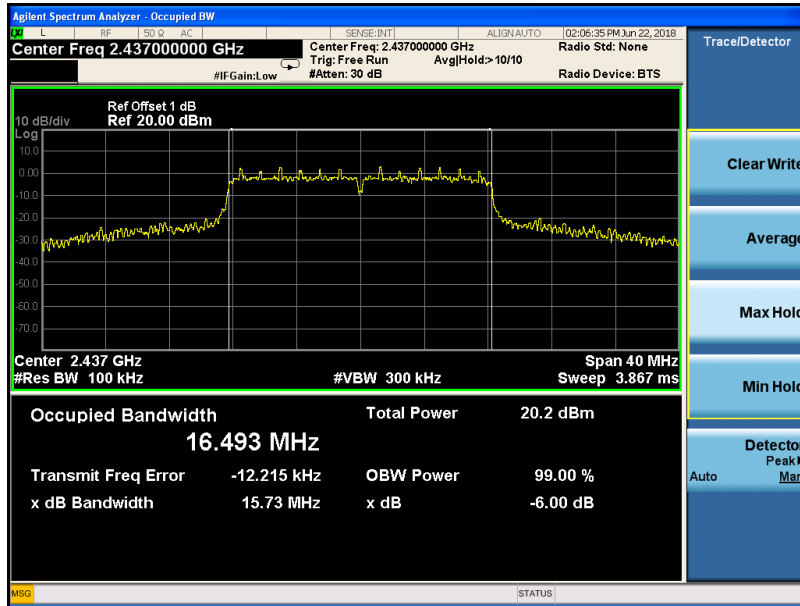

CH High

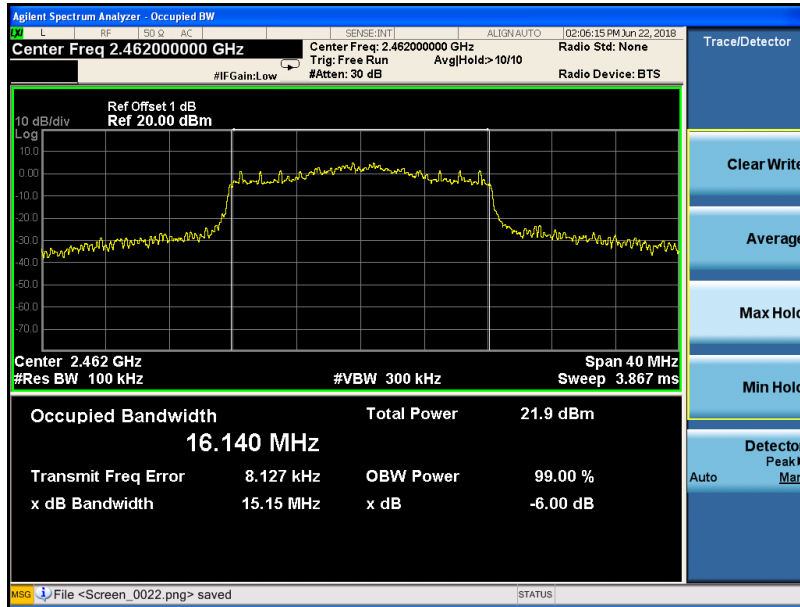

IEEE 802.11n HT20:
CH Low :

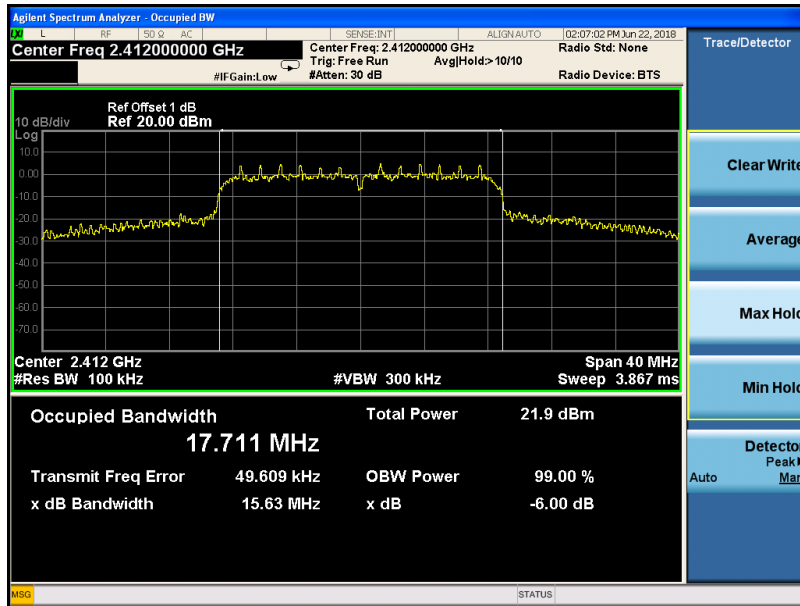

CH Mid :

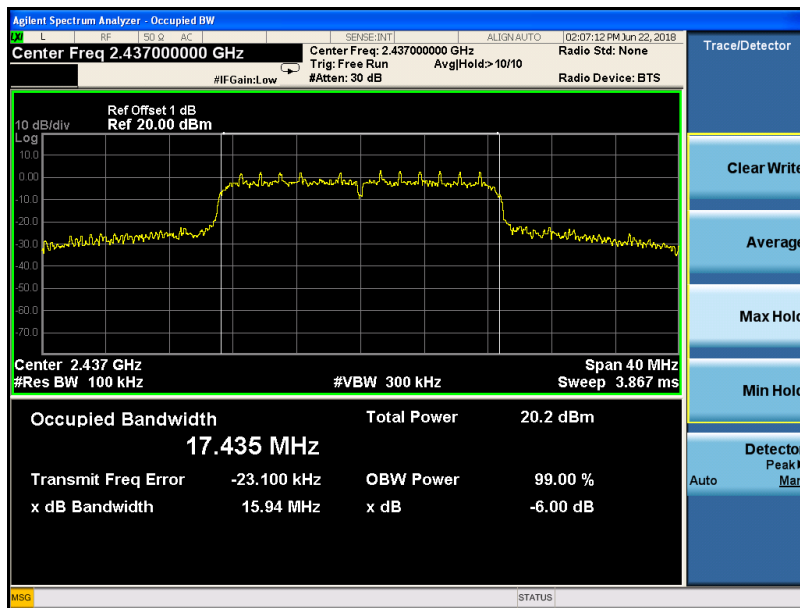

CH High :

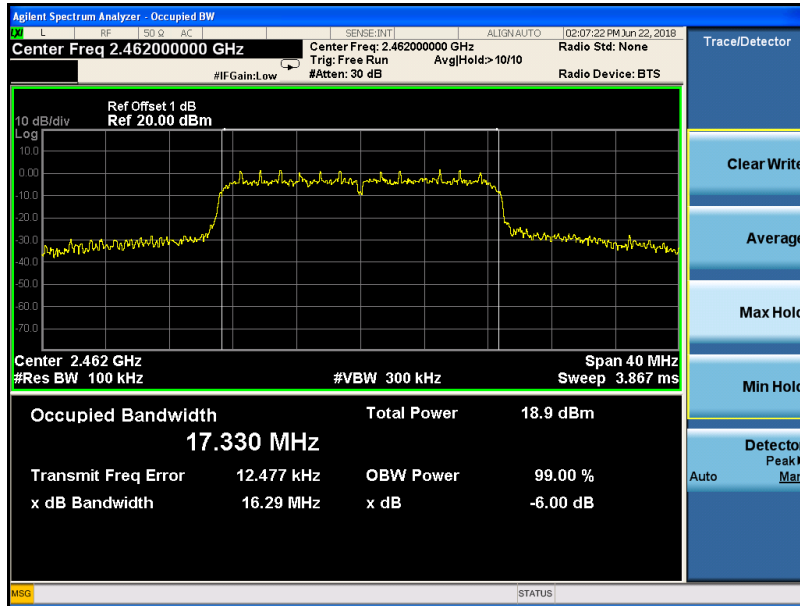

IEEE 802.11n HT40:

CH Low :

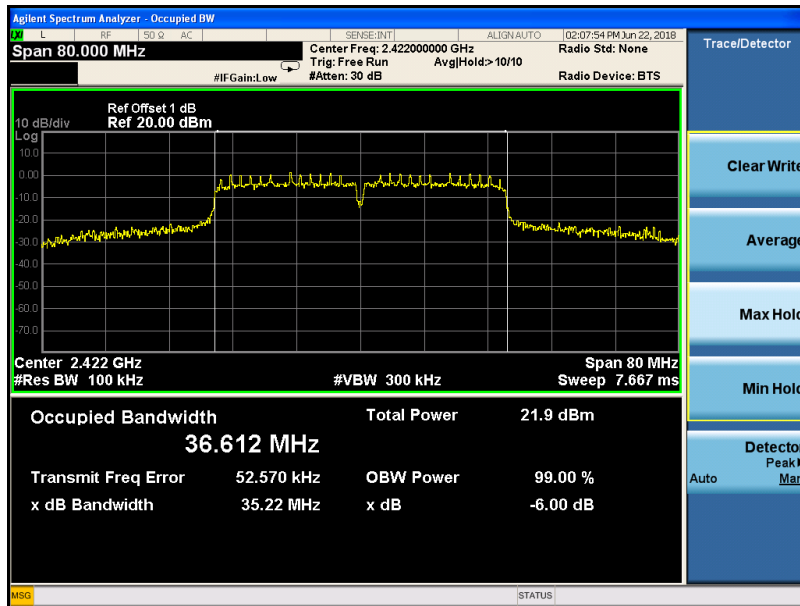

CH Mid :

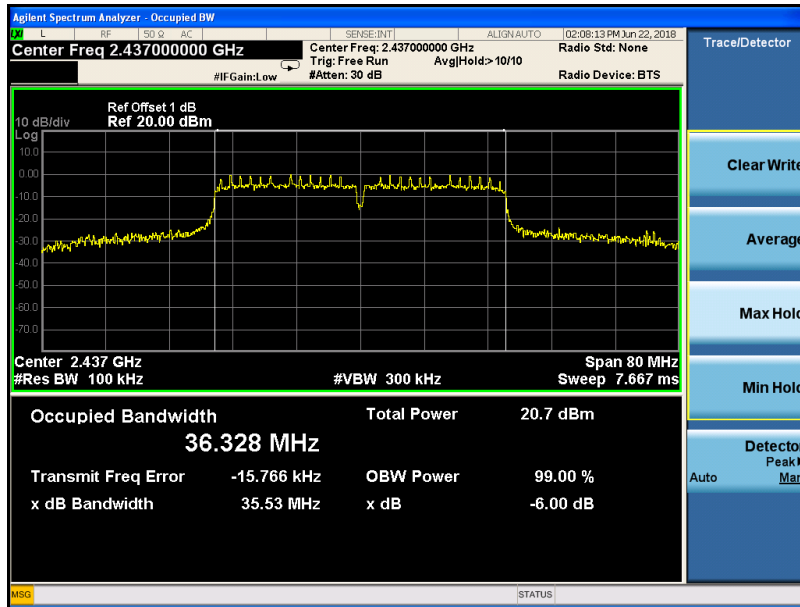

CH High :

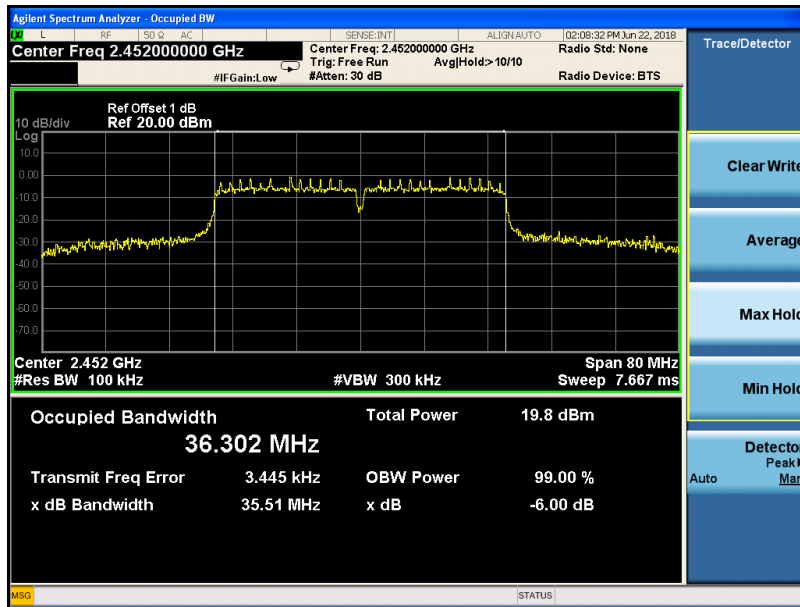

8. BAND EDGE CHECK

8.1. Test limits

Please refer section 15.247

All the lower and upper band-edges emissions appearing within 2310MHz to 2390MHz and 2483.5MHz to 2500MHz restricted frequency bands shall not exceed the limits shown in 15.209, all the other emissions outside operation frequency band 2400MHz to 2483.5MHz and 5725MHz to 5850MHz shall be at least 20dB below the fundamental emissions, or comply with 15.209 limits.

8.2. Test Procedure

Details see the KDB558074 D01 Meas Guidance V04

8.2.1 Put the EUT on a 0.8m high table, power on the EUT. Emissions were scanned and measured rotating the EUT to 360 degrees, Find the maximum Emission

8.2.2 Check the spurious emissions out of band.

8.2.3 RBW 1MHz, VBW 3MHz, peak detector for peak value , RBW 1MHz ,VBW 3MHz , RMS detector for AV value.

8.3. Test Setup

Same as 5.2.2.

8.4. Test Results

PASS.

Detailed information please see the following page.

Radiated Method:

Test mode: IEEE 802.11b TX LOW									
Freq (MHz)	Read Level (dBuV/m)	Polar (H/V)	Antenna Factor (dB/m)	Cable loss(dB)	Amp Factor (dB)	Result (dBuV/m)	Limit (dBuV/m)	Margin (dB)	Remark
2390	40.90	V	27.62	3.92	34.97	37.47	74	36.53	PK
2390	--	V	27.62	3.92	34.97	--	54	--	AV
2390	41.44	H	27.62	3.92	34.97	38.01	74	35.99	PK
2390	--	H	27.62	3.92	34.97	--	54	--	AV
Test mode: IEEE 802.11b TX High									
2483.5	42.15	V	27.89	4	34.97	39.07	74	34.93	PK
2483.5	--	V	27.89	4	34.97	--	54	--	AV
2483.5	46.61	H	27.89	4	34.97	43.53	74	30.47	PK
2483.5	--	H	27.89	4	34.97	--	54	--	AV
Test mode: IEEE 802.11g TX LOW									
2390	40.78	V	27.62	3.92	34.97	37.35	74	36.65	PK
2390	--	V	27.62	3.92	34.97	--	54	--	AV
2390	42.71	H	27.62	3.92	34.97	39.28	74	34.72	PK
2390	--	H	27.62	3.92	34.97	--	54	--	AV
Test mode: IEEE 802.11g TX High									
2483.5	43.72	V	27.89	4	34.97	40.64	74	33.36	PK
2483.5	--	V	--	--	--	--	54	--	AV
2483.5	47.21	H	27.89	4	34.97	44.13	74	29.87	PK
2483.5	--	H	--	--	--	--	54	--	AV
Test mode:IEEE 802.11n HT20TX LOW									
2390	40.45	V	27.62	3.92	34.97	37.02	74	36.98	PK
2390	--	V	27.62	3.92	34.97	--	54	--	AV
2390	41.99	H	27.62	3.92	34.97	38.56	74	35.44	PK
2390	--	H	27.62	3.92	34.97	--	54	--	AV
Test mode:IEEE 802.11n HT20TX High									
2483.5	53.71	V	27.89	4	34.97	38.24	74	35.76	PK
2483.5	--	V	--	--	--	--	54	--	AV
2483.5	54.31	H	27.89	4	34.97	42.46	74	31.54	PK
2483.5	--	H	--	--	--	--	54	--	AV
Test mode:IEEE 802.11n HT40TX LOW									
2390	42.05	V	27.62	3.92	34.97	38.62	74	35.38	PK
2390	--	V	27.62	3.92	34.97	--	54	--	AV
2390	42.05	H	27.62	3.92	34.97	40.21	74	33.79	PK
2390	--	H	27.62	3.92	34.97	--	54	--	AV

Test mode:IEEE 802.11n HT40TX High									
2483.5	43.26	V	27.89	4	34.97	40.18	74	33.82	PK
2483.5		V	--	--	--	--	54	--	AV
2483.5	46.84	H	27.89	4	34.97	43.76	74	30.24	PK
2483.5		H	--	--	--	--	54	--	AV

Note:

1, Result = Read level + Antenna factor + cable loss-Amp factor

2, All the other emissions not reported were too low to read and deemed to comply with FCC limit.

802.11b

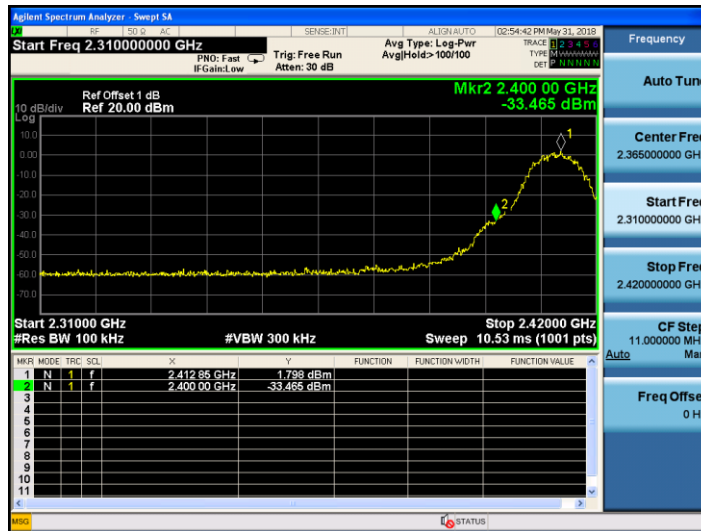

802.11g

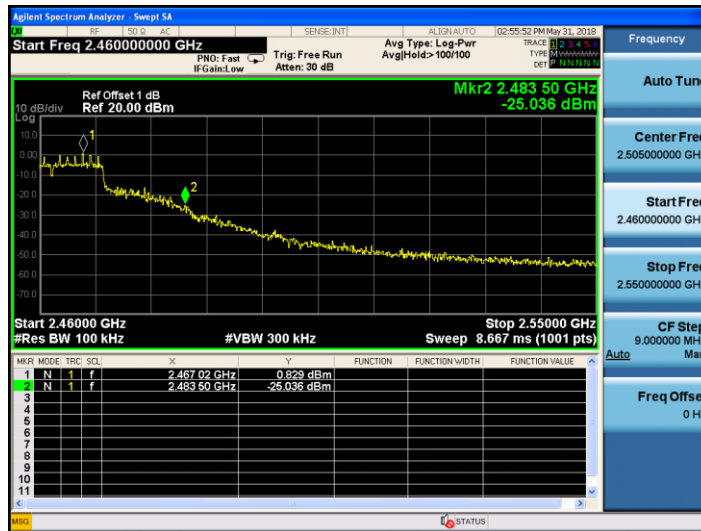
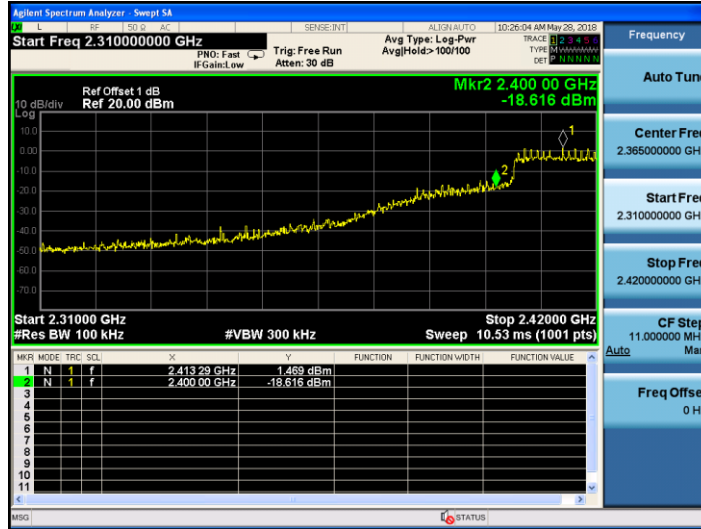

802.11n HT20

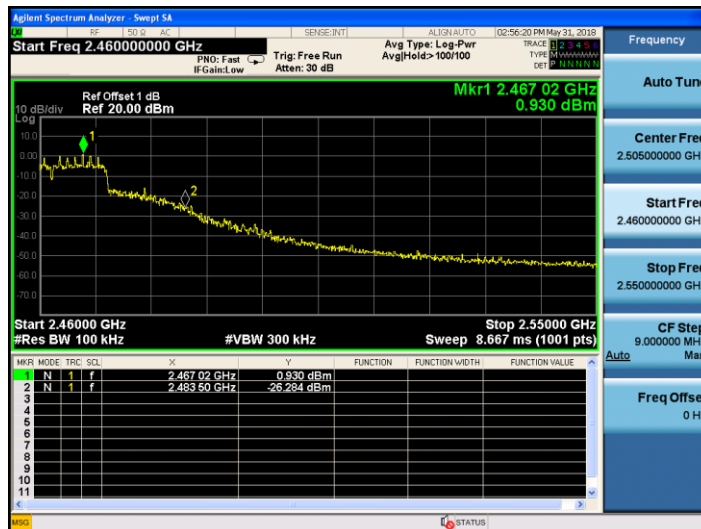
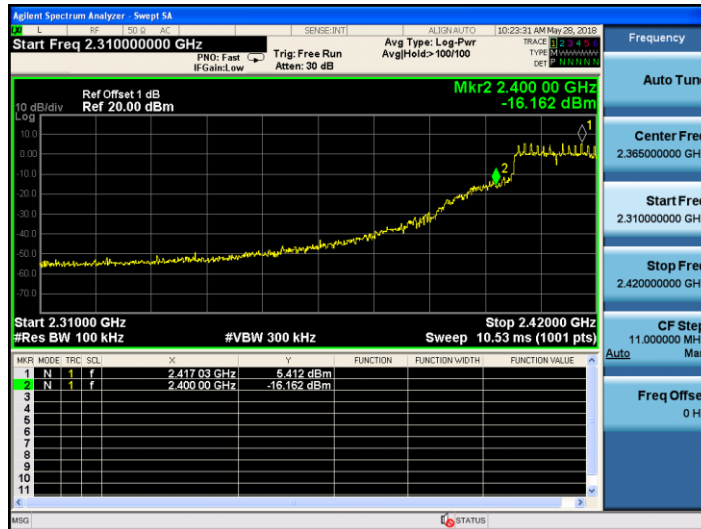

802.11n HT40



9. ANTENNA REQUIREMENT

9.1. Standard Requirement

An intentional radiator shall be designed to ensure that no antenna other than that furnished by the responsible party shall be used with the device. The use of a permanently attached antenna or of an antenna that uses a unique coupling to the intentional radiator shall be considered sufficient to comply with the provisions of this Section. The manufacturer may design the unit so that a broken antenna can be replaced by the user, but the use of a standard antenna jack or electrical connector is prohibited.

9.2. Antenna Connected Construction

The antenna is PCB antenna and no consideration of replacement. Please see EUT photo for details.

9.3. Results

The EUT antenna is PCB Antenna. It comply with the standard requirement.

10. TEST SETUP PHOTO

10.1. Photos of Radiated emission

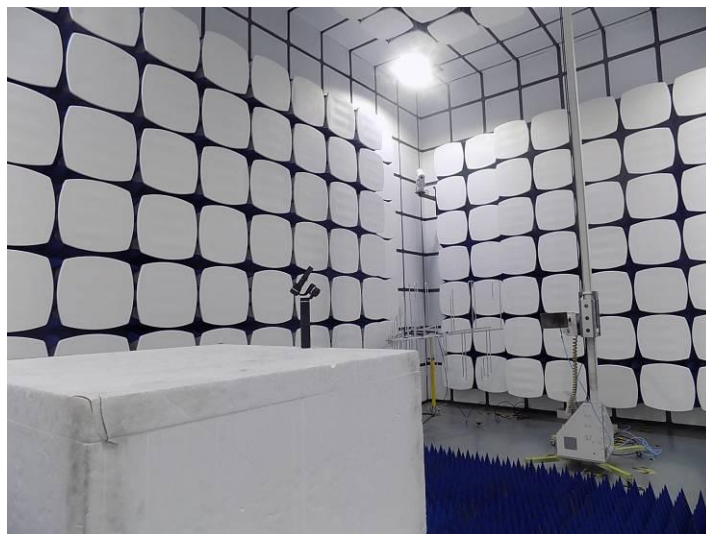
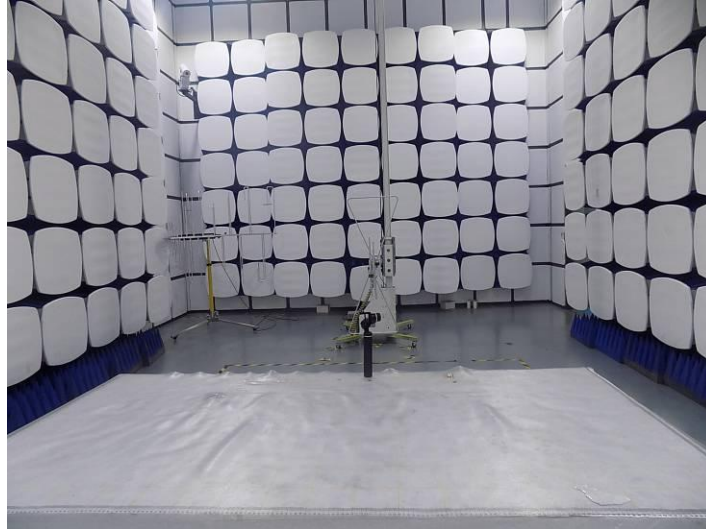

10.2.Photos of Conducted Emission test



11. TEST SETUP PHOTO













-----THE END OF REPORT-----